



International Institute for
Applied Systems Analysis
www.iiasa.ac.at

Multiregional Economic Models in Different Planning and Management Systems (With Specific Reference to the USSR and France)

Issaev, B.

IIASA Working Paper

WP-82-048

June 1982



Issaev, B. (1982) Multiregional Economic Models in Different Planning and Management Systems (With Specific Reference to the USSR and France). IIASA Working Paper. WP-82-048 Copyright © 1982 by the author(s). <http://pure.iiasa.ac.at/1968/>

Working Papers on work of the International Institute for Applied Systems Analysis receive only limited review. Views or opinions expressed herein do not necessarily represent those of the Institute, its National Member Organizations, or other organizations supporting the work. All rights reserved. Permission to make digital or hard copies of all or part of this work for personal or classroom use is granted without fee provided that copies are not made or distributed for profit or commercial advantage. All copies must bear this notice and the full citation on the first page. For other purposes, to republish, to post on servers or to redistribute to lists, permission must be sought by contacting repository@iiasa.ac.at

NOT FOR QUOTATION
WITHOUT PERMISSION
OF THE AUTHOR

MULTIREGIONAL ECONOMIC MODELS
IN DIFFERENT PLANNING AND
MANAGEMENT SYSTEMS (WITH
SPECIFIC REFERENCE TO THE
USSR AND FRANCE)

Boris Issaev

June 1982
WP-82-48

Working Papers are interim reports on work of the International Institute for Applied Systems Analysis and have received only limited review. Views or opinions expressed herein do not necessarily represent those of the Institute or of its National Member Organizations.

INTERNATIONAL INSTITUTE FOR APPLIED SYSTEMS ANALYSIS
A-2361 Laxenburg, Austria

PREFACE

This paper was presented at the IIASA conference on the Practice and Prospect of Multiregional Economic Modeling, held in Laxenburg, Austria, on November 25-27, 1981. The conference marked the close of a project aimed at providing a world-wide survey of the current practice of multiregional economic model-building and a review of the major development trends.

An important aspect in considering experiences accumulated in the area was east-west comparisons. This paper considers objective factors influencing the methodology and implementation of multiregional models in the USSR that stem from the centralized planning of national and regional socio-economic development. Some conceptual comparisons are made with the experience of France.

MULTIREGIONAL ECONOMIC MODELS IN
DIFFERENT PLANNING AND MANAGEMENT
SYSTEMS (WITH SPECIFIC REFERENCE
TO THE USSR AND FRANCE)

Boris Issaev

This paper discusses the effect of different planning systems on existing practices of elaborating and implementing multiregional economic models. Models describing regional development are interpreted in this paper as 'multiregional' when:

- they deal explicitly with regions that form a part of the national system and describe either the relations among them or their links to the national system as a whole;
- they deal with parts of large regions; these parts represent multi-faceted subsystems having specific decision-making centers within the existing planning and management system.

Only those models dealing with the socioeconomic development of regions are considered. The main discussion is based on the experience of the USSR, with some references to regional modeling in France under an 'indicative' system of planning.

In the USSR economic modeling in the field of regional development is carried out mainly by two types of organization: research institutes of the USSR Academy of Sciences and its territorial branches and research institutes of central and

territorial planning authorities that are part of 'Gosplan' (State Planning Commission). A substantial economic modeling effort is carried out by educational institutions (universities and specialized institutes), but their links with planning and management bodies are weaker than those of the research institutes.

Figure 1 provides guidelines for the analysis of economic modeling in different planning and management systems by linking analysis to combinations of elements involved (shown in cases of the matrix) below.

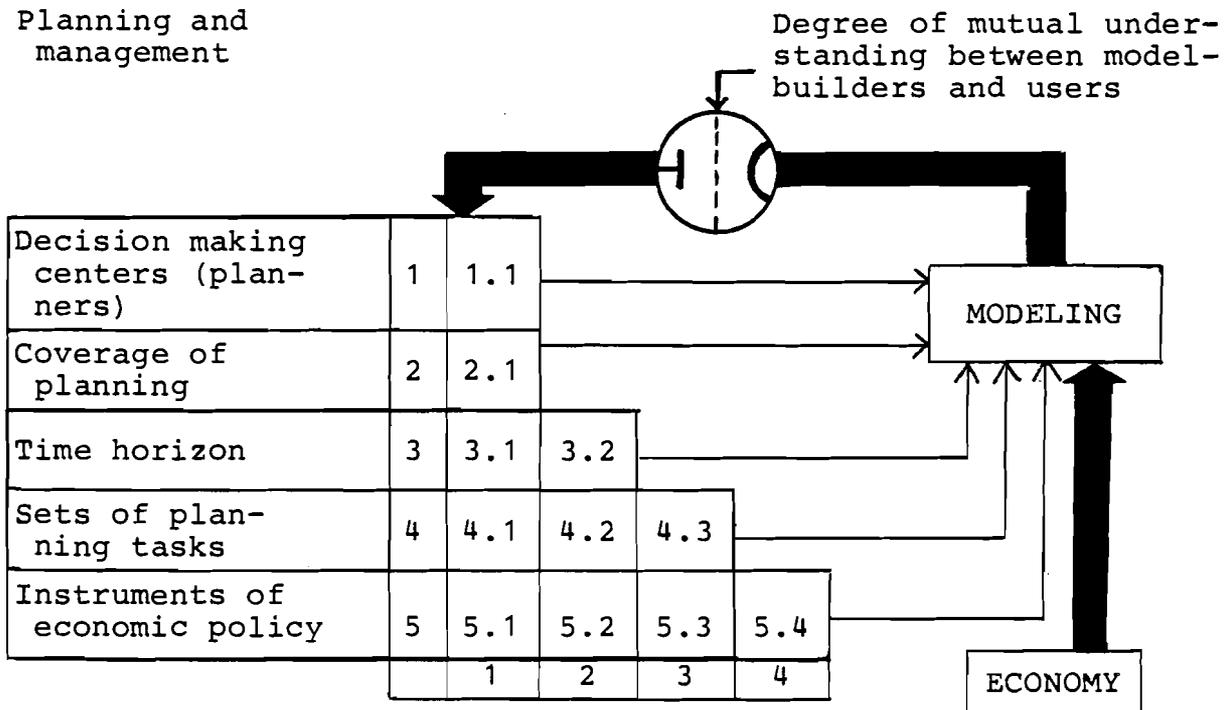

Figure 1. The influence of some features of planning systems on economic modeling.

The factors that determine the structure of the models and their methods are:

- demand by decision-making centers (1.1) for model outputs; this differs according to the type of national economy, but it can also vary within a national economy depending on the relation of specific decision-making procedures with other factors (2.1; 3.1; 4.1; 5.1);

- the scope of planning, or the extent to which socioeconomic processes are covered by planning decisions;
- the time horizon of decisions;
- the content of specific problems included in the planning procedure;
- instruments of economic policy of the state.

Other important factors of a subjective nature include the degree of understanding existing between model builders and planners, the capability of the former to communicate to planners, and the potential of the latter to use models correctly in their decision-making process.

1. SYSTEM OF REGIONAL PLANNING IN THE USSR

Although the organization of interactions between regions for the socioeconomic development of the USSR, i.e. interregional relations, is important in the USSR's system of planning, it does not constitute a major problem. The main problems of socioeconomic development of the country are decided upon at the center in accordance with the national interest. A centralized system of planning and management is realized firstly by means of a sectoral approach. The territorial dimension in national plans is represented by a specific part of the plan in which a set of documents is organized according to territorial principles. All other parts of the national plan also have a territorial break-down, which means that plan targets are identified at the regional level and their fulfillment is controlled by the regional authorities. The relations between regional systems, on the one hand, and the national economy as a whole, on the other, take the form of a dialogue in which central directives and regional targets of the plan are coordinated.

The fundamental feature of the planning system in the USSR and in other socialist countries is that the term 'planning' includes all activities ensuring the fulfillment of the plan's targets. The planning system is theoretically the form in which the socioeconomic system functions, and the organization of

the elements of real productive systems. In market economies the functioning mechanism is independent of planning. Therefore, plans are 'indicative'; they are not inherent parts of the real socioeconomic systems. This essential difference between socialist- and market-type planning is relevant for all specific modifications of the forms of planning (goal-oriented programs, current overall planning, etc.).

The scheme of planning and management of regional development within the national socioeconomic system is, in very broad terms, illustrated in Figure 2.

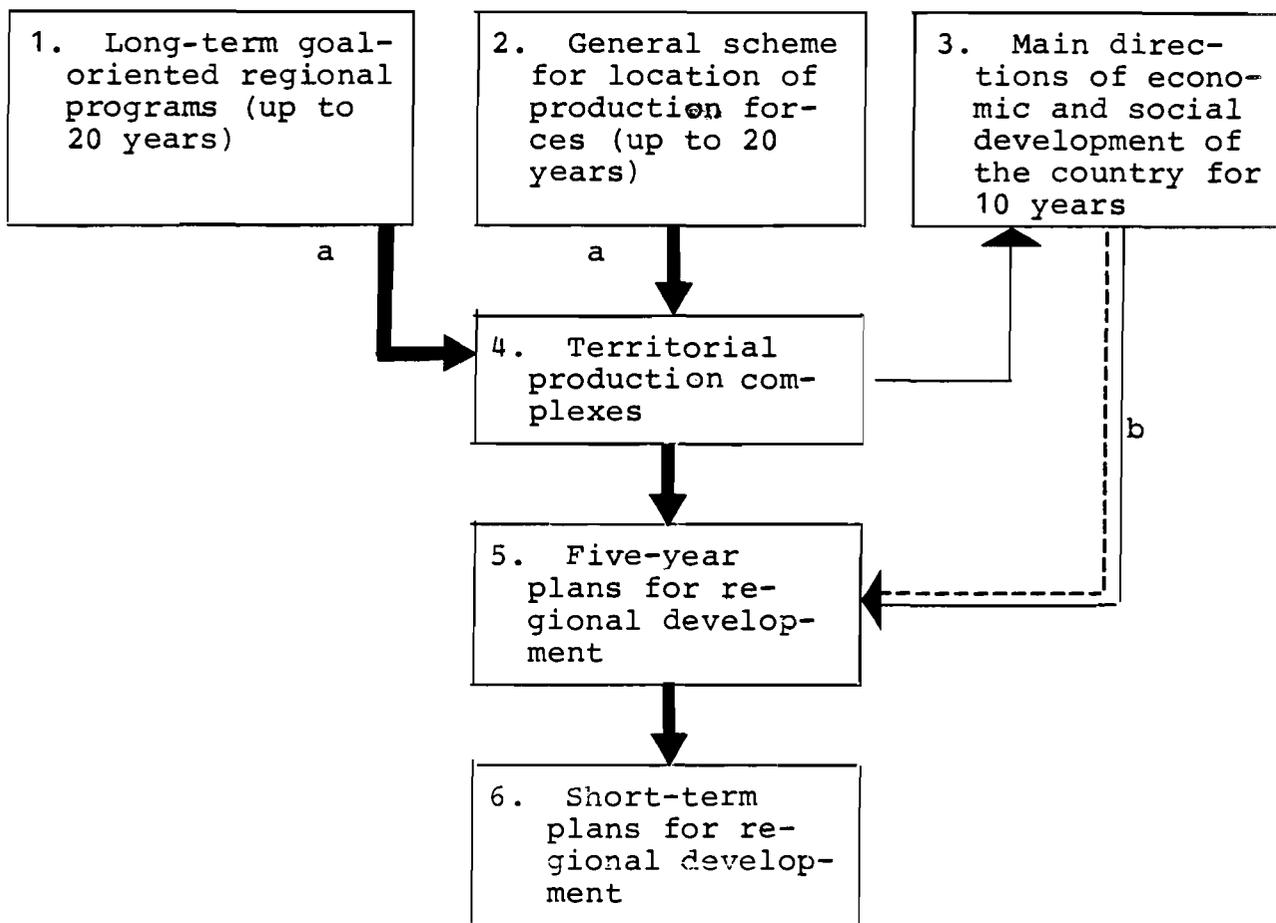

Figure 2. Main elements in planning regional development in the USSR.

The development of each specific regional system in the USSR is determined by the state through two channels:

- predominantly, territorial production complexes (TPCs), which are the vehicles through which the long-term goal-oriented program (GOP) is implemented (links a);
- current medium- and short-term plans of regional development, which form a part of the current national plan (links b).

The five-year plans of socioeconomic development for each region have a synthesizing function for these two channels.

The actual decisions concerning regional development, the use of regional and national resources, and interregional relations are based finally either on the provision of long-term GOPs or on a general scheme for the location of productive forces.

The core problem in each GOP is always of national importance. The elaboration of such programs therefore involves interactions between regional and national authorities and their implementation affects interregional and regional-national interdependencies. The following are examples of core problems: oil and gas extraction in West Siberia, erection of hydropower plants in Bratsk and Ust-Ilimsk, construction of the Baikal-Amur railway line in Eastern Siberia, brown coal extraction in the Kansk-Achinsk area, etc.

GOPs of this type have some important characteristics as systems. These characteristics determine their potential links with multiregional modeling. GOPs are open systems; they have a complex internal structure; their implementation is hierarchically organized; they are liable to scalarized optimization; and they are dynamic in the sense that time is explicitly fixed for the planning horizon and for the sequence of activities within the period covered by the program.

The role of planning, based on long-term goal-oriented regional programs (links a in Figure 2), has drastically increased since the mid 1950s, when the large-scale involvement of new energy resources and the construction of energy-consuming industries began. It became clear that these problems, which had a clear national-regional dimension and were intersectoral in nature,

could not be resolved in a satisfactory manner within traditional forms of current planning.

Territorial production complexes (TPCs) constitute a form of spatial organization of production that is aimed at achieving goals of overall national importance. Thus, the main idea behind the concept of the TPC is that it should fulfill national criteria in a regional setting. The TPC includes sets of stable objects in productive and nonproductive spheres that function in a coordinated way. These sets of objects are located within a specified area and have the necessary resources to meet their needs. Their coordinated functioning contributes to the balanced development of all aspects of the regional system and to the participation of the region in the national division of labor. These sets of objects are served by the regional infrastructure, which is also adapted to the main goals of the long-term GOP.

The elaboration, and implementation through TPCs, of long-term GOPs is normally associated with a large-scale utilization of resources of the respective region in the national economic turnover, resulting in the creation of new production and service centers. The establishment and functioning of the TPC stimulates changes in intraregional production and social patterns and leads to shifts in links with other regions. Long-term regional goal-oriented programs usually provide for profound changes in production specialization of the respective areas and for a rapid increase in the economic potential of the regions.

TPCs are created not on the initiative of local decision-making centers, but as a result of large-scale and far-reaching state action, based on national goals. The TPC also has specific temporal characteristics. To the extent to which the goal of TPC is being achieved, the system gradually loses its orientation on specific goals and continues to function within the mechanisms and socioeconomic criteria inherent in the existing system of current planning.

TPCs always require a high concentration of productive resources, normally not fully available within the region. In the traditional structure of regional management, local authorities

do not have the autonomy and management skills required to run the TPC, therefore special arrangements are required. This inevitably generates specific types of local-central decision-making conflicts for the development of the TPC region. Such conflicts may also be related to the fact that in many cases the area covered by the TPC does not correspond to the existing administrative regionalization of the country.

The relation between the dynamics of the GOP and TPC, and the dynamics of the system of current medium- and short-term regional planning is illustrated in Figure 3.

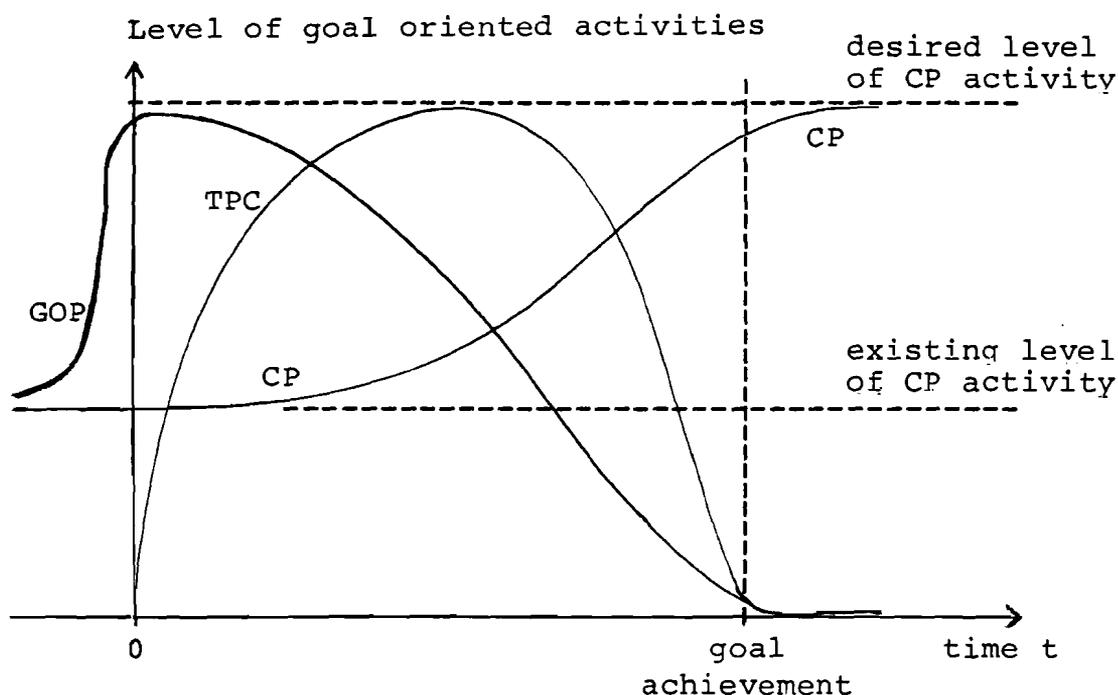

Figure 3. Coordination of long-term goal-oriented regional programs (GOP) with the current planning system (CP) in relation to the creation and functioning of the TPC.

The development of a long-term GOP begins at the existing level of current planning, where potential goals may to some extent be taken into account. Acceptance of the program implies that a TPC, which is a specific form of spatial organization of

production, is created. The goal-oriented activities of the TPC, after attaining their maximum possible level, are replaced by traditional mechanisms determined by the current planning system. But the latter is gradually directed towards the main goal of the program within the slowly changing structure of the regional system. Thus, the goal orientation of current planning increases. When the goal of the long-term program is achieved, the TPC loses its specific function and continues to exist as a set of productive and social objects under the current planning system.

When considering the effects of this specific approach to planning regional development (GOP - TPC) on regional economic modeling, and in particular on multiregional economic modeling, one should bear in mind the following properties and requirements of the GOP - TPC system:

- explicit goal orientation;
- scalarized quantification of possible goals;
- long-term time horizon;
- dynamic relations covering more than one life-cycle of fixed capital;
- national criteria behind the main goal;
- hierarchical relations, including national level;
- multi-faceted view of the regional reality (including intersectoral relationships);
- focus on main streams of activities leading to achievement of the goal, with less attention on the overall economic balance of the regional system;
- regional-national links for core resources only;
- necessity to link dynamic trajectory models (or network-type models) with static balance-type models focussing on current planning;
- explicit distinction between local and central decision-making centers in the identification of model variables;
- high degree of detail required for the main factors determining goal fulfillment;
- predominantly ad-hoc character of the main elements and analytical tools.

The GOP - TPC system, viewed as a general planning procedure, consists of:

- pre-planning studies and conclusions in the framework of long-term GOPs, and
- special arrangements incorporated in sets of decisions and documents determining the goal-oriented operation of the TPC.

Both parts need modeling support, but their modeling requirements differ. The development of a long-term goal-oriented regional program always take the form of a study at the pre-planning stage. The models supporting this study are used to obtain answers to specific questions related to the achievement of the goal. These models cannot be standardized. They are based on specific information and are used only once in the course of program elaboration. These models need not be easy to operate by users; therefore, problems of model-builder/user interface or of model sophistication do not arise. Moreover, since these models are developed as integral parts of the study and are implemented at the initial stages of their development, difficulties associated with their practical implementation are avoided. The only problem here occurs in translating the results into the language of the official documents in which the program is finally formulated.

The other part, which relates to the functioning of the TPC, is directly included in the procedure of planning proper. Since the objective here is to ensure transition of the regional system from a 'pre-program' to a 'goal-achieved' state, the main problems are associated with the development of monitoring systems along the programmed path of transition and of management--the process of far-reaching structural shifts. These models should be considered as 'tools' rather than 'studies' and should be used for as long as the special goal-oriented functions of the TPC are being performed.

The first part of the above planning procedure is dominated by scientists, but the second part relies on the skills of planning authorities and management at the regional and national

levels. Thus, the recipients of the model products are scientists in the first case and practitioners in the second. Therefore, the questions of model accessibility and unambiguous interpretation of the results are crucial to the model's chances of being applied in practice.

One of the features of the GOP-TPC system, which is relevant to multiregional economic modeling, is that it is concerned with national goals. Models supporting this line of planning emphasize the adaptation of regional patterns and national-regional relations to the nationally determined goal rather than the mutual adaptation of regional and central systems to each others goals. Since the leadership comes from the 'center', the most suitable models are those emphasizing regional-national relationships in intraregional transition processes. Region-to-region relations play a secondary role.

The current medium- (five years) and short-term (one year) planning system is based on a set of detailed standardized instructions. It is organized in the form of a dialog between local and central planning bodies around the national economic and social development goals put forward by the highest party and state authorities. Plan targets are obligatory and directly determine the economic activities of production units. Regional plans are elaborated for administrative territories of the USSR (republics and other territorial units at a lower level). Plans relating to regional development within the whole system of national economic planning are shown in Figure 4.

Regional development planning is the spatial dimension of the planning system, which encompasses the smallest administrative zones to republics. The other dimension is sectoral, including individual economic units to groups of industries. Each regional plan is intersectoral and is based on the management system. Recipients of plans are all-union or republican ministries or administrative bodies at the lowest levels.

The number of objects in current regional planning in the USSR amounts to 191. They range in size from macro-regions to districts, the main unit being the republic. The plans are

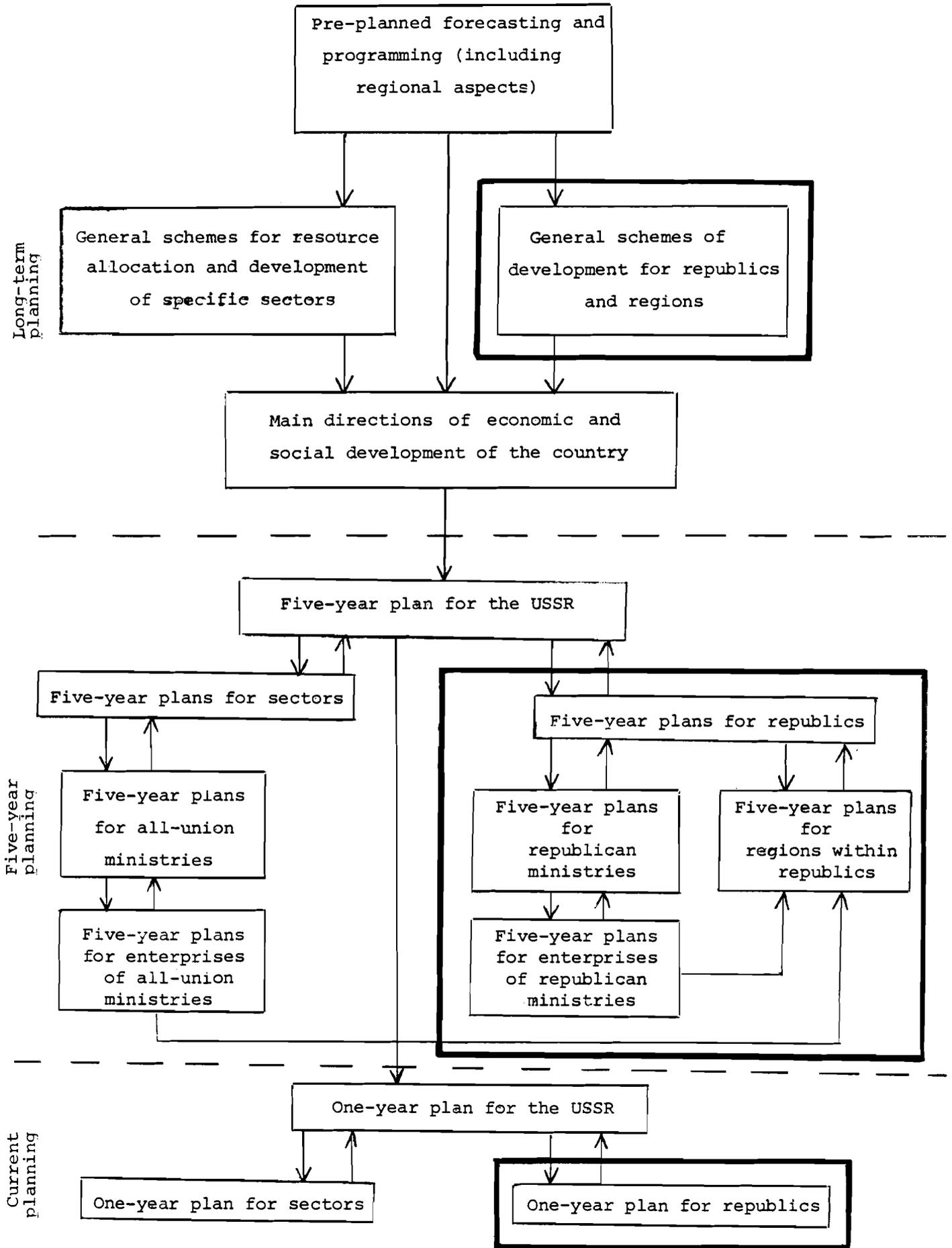

Figure 4. The Soviet planning system.

broad in scope and detailed in their description of each aspect of the regional reality. As can be seen in Table 1, which shows the main groups of economic and social indicators for certain centrally planned economies, current plans of regional development are biased towards physical aspects of the economy, strongly emphasized social targets, land and water resources, as well as the production and social infrastructure. In multiregional modeling analyses of regional inequalities, the models used should be linked to the current system of planning rather than to long-term GOPs.

In centrally planned economies, the planning documents determine the demand and supply of the principal material resources of each region. These documents also specify the transportation mode for delivery of each item to the consumer. In the USSR the central planning body calculates balances for up to 2,000 types of good. At the regional level, where the authorities are responsible for supplying the production units with primary and intermediate consumption goods, the number of balances amounts to more than 13,000. This planning activity at the central and local levels includes a matrix of interregional commodity flows, which is used as the basic planning document for the transportation sector. Thus, the interregional approach is used in the joint planning of the supply and transportation of goods.

One important methodological characteristic of Soviet regional planning relevant to the development of multiregional modeling is the accounting frame. This frame takes the form of a 'Balance of the National Economy' for each republic, which incorporates the Material Production Based System (MPS)--one of the two basic systems of socio-economic accounting in use throughout the world, the other being the System of National Accounts (SNA) employed in market economies.

The set of balance-type tables of the 'Balance of the National Economy' is elaborated for the national and regional (republic) levels. The only exception is the table of financial resources and expenditures, which is not elaborated at the republic level. The sum of the regional balances should correspond to the national balance.

Table 1. Main groups of indicators in the current five-year plans of regional development for specific centrally planned economies.

Groups of Indicators	USSR	Bulgaria	Hungary	DDR	Poland	Czechoslovakia
Population		x	x	x	x	x
Labor resources	x	x	x	x	x	x
Employment	x	x	x	x	x	x
Wages, by sector	x			x	x	
Balance of monetary income and outlay of the population	x	x	x	x		
Industrial output by sectors	x	x	x	x		x
Agricultural output	x	x	x	x	x	x
Agricultural area		x		x	x	x
Forestry		x	x	x	x	x
Volume and structure of capital investments	x	x		x		x
Transport network		x	x	x	x	x
Communications		x	x	x	x	x
Water-supply system		x	x	x	x	x
Energy resources		x	x	x		
Storage capacities			x			
Housing stock	x	x	x	x	x	x
New dwellings	x	x	x	x	x	x
Supply of social services	x	x	x	x	x	x
Number of beds in hospitals per 10,000 persons	x	x	x	x	x	x
Number of doctors per 10,000 persons	x	x	x	x	x	x
Number of places in social service institutions			x	x		x
Recreation activities, tourism		x		x		x
Education	x	x	x	x		x
Volume of marketable services	x		x	x		x
Retail trade turnover	x		x	x		x
Environmental protection	x	x	x	x		x

Source: L. Pasieczny, ed., 1981.

In each republic the following balances are used as planning documents:

- balance of production and use of social product;
- balance of production, distribution, and redistribution of national income;
- balance of fixed production funds;
- balance of monetary income and outlay expenditures of the population;
- balance of labor resources.

Balances relating to production activities are compiled for production sectors on the basis of the 'enterprise' concept (sectoral approach within the republics).

Interindustrial flow balances of the Leontiev-type are developed for the plan horizon in every republic. They do not form part of the set of formal planning documents, but rather serve as analytical support for the elaboration of production programs for industrial sectors. Usually input-output tables and models are developed for regional planning purposes by the research institutes of republican planning authorities. They are elaborated for republican and national levels by means of standardized methods and provide the methodological framework for multiregional modeling. The balances of social product and of national income are methodologically incompatible with the input-output interindustry balances.

The planning authorities require that model builders adapt their models to official sets of planning indicators and to existing information systems used for planning. Two computerized systems, which substantially determine the economic modeling requirements, are now under development at the regional level:

- computerized system of planning (ASPR);
- computerized system of management at the republican level (RASU).

The first system is oriented towards production quota documents for medium- and short-term plans, the second towards monitoring the fulfillment of regional plans. This line of development in

the system of national and regional planning influences the modeling activity, since the models should finally be included into ASPR and should also be based on information available in RASU.

In comparison with the GOP-TPC system, the CP system has no clearly specified scalarized goal. The theory of socialist reproduction together with the pressure of acute economic problems determines the direction of current regional planning. In most cases the goal is not one of transition and restructuring but of balanced growth that can be adjusted to a better solution of current problems of the regions. The main objective behind current planning is to increase the volume of output under resource constraints. Inertia either in a productive activity or in the level of output achieved is one of the factors determining plan targets.

In current planning there is not such an emphasis on national criteria as in long-term goal-oriented regional programs. The planning procedure is an equally weighted dialog between the regional and national levels. The position of the regional partner in this dialog is determined predominantly by social objectives and production level achieved as well as by environmental protection considerations.

When considering the implications of the current system of regional planning for trends in modeling regional development, the following points should be emphasized. In models developed to support the current system of regional planning, there are less logical grounds for optimization. Simulation of different kinds of equilibrium is preferable. Optimization is usually introduced through maximization or minimization of quality indicators (profit, factors' productivity, discounted costs, etc.). Because of the equality of the participants in the planning procedure, the models should adequately describe reconciliation of conflicts in different settings (gaming). In contrast to 'ad-hoc' models that support decision making under long-term goal-oriented programs, models developed for current planning should satisfy certain requirements to be used effectively. These requirements relate to:

- integration between different aspects, because current planning is integrated;
- interface with users, who should communicate with the model in their own language;
- information;
- standardization, because the models should be included into the ASPR and RASU computerized systems.

2. MULTIREGIONAL MODELING IN THE USSR--MAIN DEVELOPMENT TRENDS

In contrast to market economies, where national planning systems evolved parallel to economic modeling, in the USSR planning has a long history whereas extensive economic modeling began only at the beginning of the sixties. Historically, input-output models played an even more important role in the analysis of integrated regional development than in modeling reproductive processes at the national level. This is due to the fact that macroeconomic and sectoral analysis at the national level was traditionally based on the national economic balance, which in socialist countries is equivalent to national accounting. The quality of national economic balances on the regional level was not adequate in all republics, because the system of indicators included in the balances was not sufficiently coordinated. The compilation of input-output tables for all republics in 1966 and 1972 provided a strong stimulus to intraregional and multiregional modeling activities. The input-output models and their modifications now constitute the methodological basis for modeling regional development. The other most widely used tool in regional and regional-national planning models is linear programming, which is also explained through tradition and linked with the work of Kantorovich.

In the USSR the first multiregional optimization models were developed by Kossov (1963) and Aganbegian (1963). The fundamental problems of an optimized interregional system were formulated mathematically but there was no empirical application of these models.

The first experimental multiregional analysis based on a mathematical model was carried out in 1967 by Granberg (1973). This model is referred to as OMMM.*

This first type of interregional model pioneered by Granberg is based on the concept of 'interregional interactions', which consists of the regional approach to multiregional modeling in a single-level system. Experimental work with another type of interregional model was carried out in 1971 by the Council on Studies of Productive Forces of the State Planning Committee of the USSR (CSPF). This work, supervised by Nikolaev (1971), had a clear production allocation orientation. The third type of interregional model was developed and implemented on the computer at the Central Economics and Mathematical Institute of the Academy of Sciences of the USSR in the period from 1972 to 1980. The theoretical background was initially formulated by Baranov, Danilov-Daniljan, and Zavel'ski (1971) and the version of the model implemented at the end of the seventies (SMOPP)[†] was developed by Baranov and Matlin (1981). The main conceptual characteristic of this model is its hierarchical and multidimensional structure. The latest version is called SMOTR.[‡]

OMMM

OMMM was used for analyzing the interregional distribution of outputs of 16 industries among 10 economic zones in 1966. The main idea of the model is very simple: to combine into one optimization model the information contained in all regional input-output models. This model, which takes national criteria into account, allows the actual and the optimal locations of production to be compared and different alternatives for the territorial organization of the national economy to be evaluated.

* OMMM in the Russian acronym for 'Optimized Interregional Interindustrial Model'.

† SMOPP is the Russian acronym for 'System of Models for Optimal Prospective Planning of the National Economy'.

‡ SMOTR is the Russian acronym for 'System of Models for Coordinating Sectoral and Regional Decisions'.

Two versions of the model were used for the analysis. In the first version, optimization of regional production patterns is achieved for production capacities remaining at the level of the base period. In the second version, all industries can increase their fixed capital. The most important factor influencing production costs is economy on transportation. The overall objective function in the model is the growth rate of final consumption.

OMMM is a set of regional blocks linked by common constraints on the national supply of resources, national goals, interregional exchange of goods, and transportation flows. The general scheme of OMMM is shown in Figure 5.

The basic version includes:

- regional input-output balances with special emphasis on external relations for the final year of the planning period;
- balances of labor demand and supply, taking into account forecasted migrations;
- constraints on capital investments for the entire country and for the planning period;
- specific constraints on interregional flows of goods, production capacities, and the use of natural resources.

Under these constraints, it is possible to find those regional production programs and interregional commodity flows that maximize the growth rate of final consumption for the whole country, under the given material structure and regional distribution of consumption.

In the second version, the exogenous constraints on capital investment volume are replaced by mathematical laws of capital investment changes. The parameters of respective equations and absolute values of investment volumes are found as a solution of the model. The LP problem formulated on the basis of OMMM includes 162 basic constraints and about 700 variables.

The economic information required for OMMM is generally the same as that needed for calculating planned input-output balances

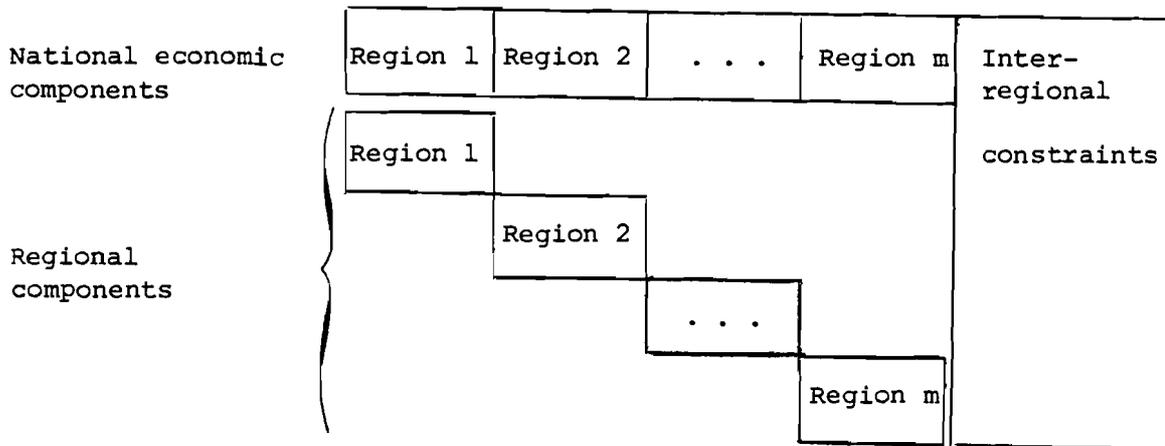

Figure 5. The Optimized Interregional Interindustrial Model (OMMM).
(Source: Granberg 1973.)

for production and capital investments. Specific information is also required for the regions' exports and imports and for transportation costs. OMMM is a single-level interregional model in which there is no explicit higher level system acting as a decision-making center.

Several successive versions of OMMM have been developed so far and prospective development paths up to 1990 have been calculated. At present this model is being introduced into the ASPR system as a tool for preplanned regional analysis.

Two other original multiregional models also relating to the OMMM family of models should be mentioned here.

- An 'east-west' model for distributing centralized resources between respective parts of the USSR. The model consists of an interactive reconciliation between two autonomous LP models through equalization of dual values of common resources in each system (Granberg and Chernyshev 1970).

- A model with regional response functions (Marjasov and Suslov 1980). In this model structural characteristics of regional systems in terms of input-output relations are replaced by regional functions explicitly linking output parameters with input parameters from the upper level. To maximize the regional function, the value of the regional production vector is determined at the regional level. This is dependent on two vectors: constraints on national resources and export-import balances.

The CSPF Model

The model developed by Nikolaev deals with the location of 25 groups of products in five large economic zones. The main features of the CSPF model are:

- it is an LP model of input-output type;
- only the problem of locating material production is solved under exogenously given growth rates of outputs and proportions for the national level;
- the objective function is minimization of production and transportation costs at fixed prices, wages, and tariffs;
- products considered in the model do not exhaust the entire material production;
- no inputs to transportation are taken into account;
- the model is static;
- final demand in regions and at the national level is fixed exogenously.

Although this model deals with regions and with the national economy, it can hardly be classified as a multiregional model as defined in the introduction to this paper. The reason is that the regions are not considered as decision-making centers and only those links from the center to regions optimized according to national criteria are analyzed. Interregional links are determined in the CSPF model only for the transportation of goods.

SMOPP-SMOTR

SMOPP-SMOTR is clearly an ASPR-oriented (computerized system of planning) tool for multiregional and multi-aspect optimal planning. It has been developed in close contact with regional and central planning authorities and planning research institutions. This system has been tested in the Computing Center of GOSPLAN.

SMOPP is used for coherent optimization of sectoral and regional planning, including planning of interregional transportation of the most important goods under constraints on labor and natural resources. Thus, it allows national goals to be reconciled with the social interests of each region. It is a large system of linked modules for each region and for the nation that includes special 'functional' modules describing aspects and activities not covered by input-output models. The system includes 24 models of specific regions, one interregional model of migration, 12 models of transportation, 16 sectoral models, and a 'central' model for the national level. Ninety-eight products, 33 types of labor resources, and 7 groups of natural resources are specified in SMOPP.

The main concept of SMOPP consists in a combination of input-output and econometric modeling of two aspects of the socio-economic reality of the country: industry and space. Optimization is achieved for the national industry model system and for each regional system. Reconciliation of interests is achieved as a result of an interactive procedure between regional and sectoral systems. Although this system of models uses a combination of 'top-down' and 'bottom-up' approaches for causal linkages, the predominant direction of analysis is from the national level to the regional level. The model describes the modification of centrally planned regional production patterns to account for regional constraints and interests.

The main exogenous variables for the central model are the maximum volume of capital investment in production sectors, total volume of personal income in the non-productive sphere, and the supply of specific products. In regional models the main exogenous variables are average yearly supply of each resource item for production consumption, overall supply of labor resources, yearly balances of migration, and constraints on production

capacities at the first iteration. In the migration model the exogenous variables are personal consumption by regions and years, income per capita, retail trade turnover per capita, and rate of growth of social capital in each region. In the transportation model the main exogenous variables are production and consumption of goods by regions, coefficients for transition from terms of outputs and consumption of goods to terms of weight-based categories of goods, limits on two-way deliveries, and transportation capacities. Sectoral models have exogenous constraints on the use of products in short supply, targets on the production of goods considered to be in short supply in the whole system, constraints on production capacities and capital investments, and regional costs of production for each product. The respective objective functions are:

- in regional models--maximum income for the population;
- in transportation models--minimum transportation costs;
- in sectoral models--maximum integral profit of the sector for 10-year periods;
- in the 'central' model--maximum overall effect from the use of natural and labor resources.

The solution of the system provides for each year 25,000 figures for outputs, capital investments, and new production capacities to be put into operation; about 27,000 figures for the demand and supply of labor and natural resources; 19,000 figures for retail trade turnover by commodity groups; 6,000 figures for interregional migration; 64,000 figures for interregional flows of transportation.

The main interregional links in the system are not direct but through the sectoral and 'central' models. Direct region-to-region links relate only to migration and to transportation models. The model is dynamic and mainly linear. The mechanisms formalized in the model reflect interdependencies between physical values with the only exception for retail trade turnover and the consumption function, where monetary incomes are among the explanatory variables. The principal type of relationships in the model are technological interdependencies reflected in input-output tables. Therefore, the quality of the model and

adequacy of the results almost entirely depend on the accuracy of the technological coefficient values and their effect on small and highly specialized regions as compared with coefficients of the national input-output table.

The model has been tested using two sets of input-output tables for 1966 and 1972. (The current practice in the USSR is to compile national and regional input-output tables every five or six years.) Thus, the SMOPP model may be used as a tool for planning the extent to which reliable technological coefficients are available both for the past and the future.

In 1980 a new version of this model--SMOTR--was developed (Figure 6). A description is given in Baranov and Matlin (1981). Its goal is, in principle, the same as that of SMOPP. SMOTR simulates a number of alternative policies and analyzes the consequences of each one in order to determine a general structure for the national plan in which the sectoral and regional dimensions are coordinated.

The system of models operates on three levels. At the first level, which is national, production patterns for 18 industries are determined in accordance with the main national goals for social and economic development of the USSR. The second level is also national, but material production is analyzed here in terms of 260 products. At this level sectoral and regional indicators are checked for their consistency with the national dimension of the plan. The third level embraces detailed calculations for industrial complexes and for regions. SMOTR includes modules of 'population and labor resources', 'income and consumption of the population', 'non-productive sphere (services)', 'finance', 'foreign trade', and 'natural resource use and environment'. During the model runs, most modules interact with all three levels. The only exception is the 'finance' module, which is linked to the aggregated national model.

SMOTR is a computerized system, which obtains from the user information on indicator values reflecting the goals for the end of the planning period. At the first level of the system, this goal-oriented scenario information is analyzed for compatibility

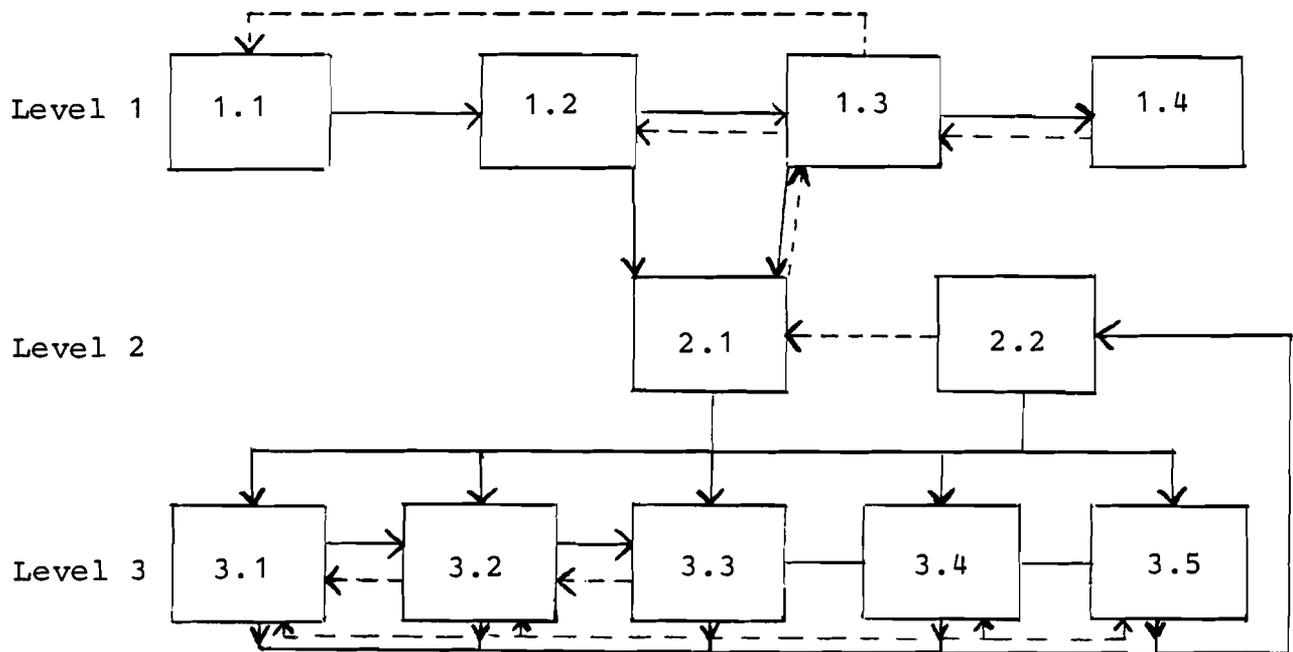

- 1.1. Overall macroeconomic indicators
- 1.2. Goal indicators for national economic development
- 1.3. Simulation dynamic input-output model 18 x 18
- 1.4. Model of interindustry flows based on sectoral production functions

- 2.1. Dynamic model based on integrated products value flows interindustry balance (260 products)
- 2.2. 'Center' model

- 3.1. Models of individual industries and industrial complexes
- 3.2. Model of industrial complex construction
- 3.3. Module of regional models
- 3.4. Module of transportation network
- 3.5. Models of intermediate goods supply

Figure 6. General configuration of SMOTR. (Source: Baranov and Matlin 1981.)

with the available resources subject to the main parameters of productive processes. If they are compatible, an optimized path of the goal achievement is determined. If not, a dialog between user and system is initiated. This finally results in changes in the values of the input indicators. The system provides information on unavailable resources, which indicates that the user should change the entry values in order to find a solution.

In the existing version of SMOTR the following set of indicators is used: average monthly level of wages and similar payments per employee; payments from social funds per capita; other monetary incomes of the population also per capita; housing in square meters per capita; number of places in schools and other educational institutions per 1,000 persons; number of places in hospitals per 10,000 persons; allocation of resources from the production sphere to non-production services per capita; exports, imports, expenditures on research, and some other social needs.

Optimization of the development paths is carried out for those indicators representing the goals of the plan. For goal targets related to exports, imports, expenditures on science and other social needs, the trajectory is introduced by the user, exogenously, and is kept unchanged while running the system. For other goals the desired values are given only for the end of the planning period. The trajectories for goals of the second type are linked with each other through constant ratios, which are implied in figures fixed by users for the end of the period. This assumption allows an optimal solution to be found for any one of the goals, by means of linear programming with a scalarized objective function.

At the second level the planning targets, which correspond to goal values, are transformed from 18 industry classifications into the detailed classifications of 'integrated products value flows balance' of the input-output type. Convergency of 260 products to 18 is achieved by iterative aggregation. At this level the core is a dynamic model of integrated products value flows balance.

At the third level intraregional spatial models are introduced for determining the location of plants. This is done in two ways: in value terms, as production of an aggregated type of commodity, in physical terms for detailed classification of 260 products. The objective function for the location problem is to minimize the cost of the resources required for production. SMOTR allows non-standardized models to be included for the solution of the location problem at the third level. At present two pilot non-standardized models are included in the system-- steel industry and agriculture. In these models, technological aspects are given special attention.

The regional module solves a set of optimization problems related to regional patterns and location of production to achieve maximum satisfaction of social needs within each region. Regional detailization of SMOTR is the same as for SMOPP: it includes 24 areas. The solution is obtained through iterations between two LP problems: one, for production aspects of regional plans, the second, for social and environmental indicators. The final solution of the regional models gives the values of the integrated products value flows balance for each region for the plan. Solutions of problems at the third level are checked for consistency with the national production program at the second and the first levels. At the first level the reconciliation of regional and national plans is achieved through minimization of a function representing weighted values of discrepancies between the optimal values of national and regional production programs.

The development of SMOTR represents substantial progress in CP-oriented multiregional modeling. Experimental runs of the system are currently being performed.

3. IMPLICATIONS OF THE CENTRALIZED SYSTEM OF PLANNING IN THE USSR FOR MULTIREGIONAL MODELING

All multiregional models considered or mentioned in this paper have an explicit imprint on the centralized system of planning the national economy. The idea of regional development from the 'center' is characteristic not only for SMOPP or SMOTR, which by definition are national models, but also for OMMM.

The latter, although a single-level multiregional model, is entirely addressed to the central planning authorities. It provides them with information about what would happen in regions under different scenarios for national production policy and how to use regional constraints and organize their mutual relations through commodity flows to obtain the best overall results. SMOPP and SMOTR devote more attention to regions as autonomous subsystems having their own decision-making centers than does OMMM. The regional blocks in SMOPP and SMOTR are considered as independent partners acting on the basis of their own objectives. Thus, the 'central' bias in the best and the most elaborate models in the USSR is obvious.

The directive character of the Soviet system of national planning is reflected in the predominance of the normative modeling approach to regional development. The preference for linear programming techniques may also be attributed to this feature. It is assumed that whatever criteria were chosen for optimization, the policy-making authorities would have sufficient means to achieve them in the conditions given by the solution of optimization problems. The objective functions in the models are not derived from analyzing the actual behavior of socioeconomic actors but rather are prescribed to the systems. Models are deterministic.

The direct link between the planning and management systems in the USSR and the state of multiregional economic modeling is also seen in the degree of challenge. The SMOPP-SMOTR system of models has no precedent. Only in a society in which the reproductive process is based on state property and is directly managed by the state at all levels can these models be useful.

In the context of actual planning and management of regional development, it is evident that modeling efforts for regions have not yet succeeded in linking intraregional developments with the multiregional environment and central decision-making. This link exists, as was stated in the first paragraph of this paper, but in the planning system it is realized through traditional rather than model-based procedures. Multiregional models serve the planning needs of the central authorities only.

There have been considerable efforts to introduce economic modeling into regional systems of planning and management and to develop appropriate computerized information systems for regional decision-making. It is evident that in the future intraregional models supporting regional decision making should be linked with models such as OMMM or SMOPP-SMOTR, and Soviet model builders are aware of this. It is necessary for supporting the dialog between regional and national planning authorities in formulating economic policies and in elaborating regionalized plans of national economic development. This will be done by further extending and improving ASPR so that the regional and national levels and the regional and national computerized systems of socio-economic information are integrated.

Considering the practical use of existing multiregional models in the actual planning procedure in the USSR, one should state that multiregional models are not currently operational in the planning system. This does not mean that the models are inadequate, but rather that further efforts are required from the scientific institutions offering the models from the institutions and authorities responsible for the development of ASPR and the computerized information systems.

All models referred to above have been experimentally implemented for use in pre-planning analysis carried out within planning bodies (Figure 7). ASPR should be developed so that it can incorporate models of a multiregional type. The intersection of the areas depicted in Figure 7 has not been fully elaborated.

Multiregional modeling trends reflect this orientation within ASPR. The models tend to operate with economic indicators that are either direct plan targets or clear combinations of them. They are also based on the present regionalization of the country in planning regional development:

- 15 union republics;
- 19 economic regions, of which 6 coincide with union republics or are combinations of them and 13 are subdivisions of the Russian and Ukrainian republics;
- 4 macrozones.

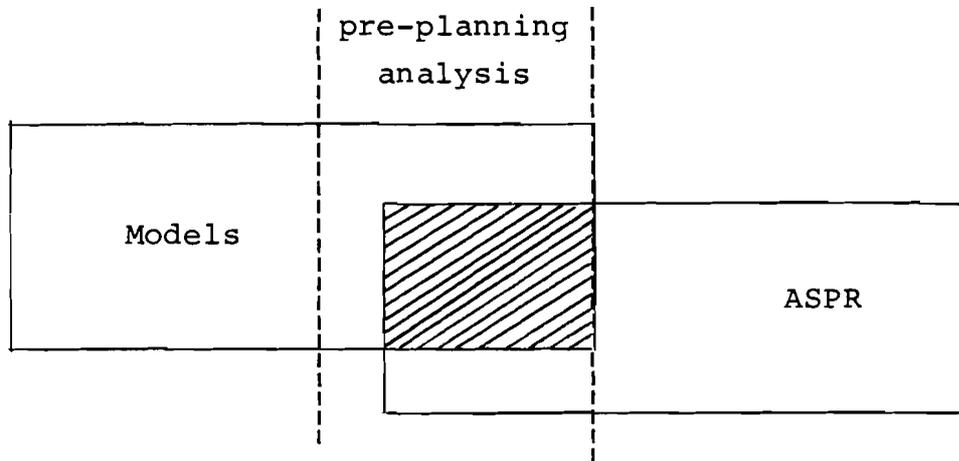

Figure 7. The proposed intersection between models and ASPR.

They tend to rely on standardized information currently used for planning. There is also a clear tendency (especially in the case of SMOPP and SMOTR) towards the development of an active interface between planners and the models in the language of planning, as well as towards the establishment of standardized data banks.

The main goal of ASPR is to produce, by means of computerized calculations, a series of versions of draft plans for all levels--national, republican, local, sectoral, and territorial--that comply with the existing framework of procedural regulations. The functional subsystems of ASPR are oriented towards elaborating all parts of the current plan and of the long-term GOPs. ASPR is currently being used to solve a set of real problems. The multi-regional model should constitute a specific set of problems in ASPR.

It has been mentioned that the two main multiregional models OMMM and SMOPP-SMOTR are based either directly on input-output tables or on derivatives of them. Although this methodological characteristic is quite reasonable per se, it presents serious problems when integrating the models with ASPR.

The Soviet planning system is based on a great number of so-called material balances for each important group of products. All plan targets determining what should be produced and delivered and to whom are specifically intended for decision-making centers--

enterprises, ministries, local and republican authorities, etc. As has been mentioned in Part 1, the synthesized targets of the plan are elaborated within the accounting frame of the national economic balance, in which the sectors and other economic agents are formed from real units as decision-making centers and recipients of the plan. All these are methodologically incompatible with the the 'pure branches' of input-output models and with the general nature of its indicators and technological coefficients.

Therefore, multiregional modeling can be used to overcome this methodological obstacle by introducing a product dimension into the input-output model, in which the objects of material balances in the planning system are combined to form the products. In SMOPP-SMOTR, 'integrated product value input-output balances' are used. The product part of the balance is very detailed and the value part is represented by the traditional type of financial indicators for production unit plans.

The system of centralized planning in the USSR is production-based. Although the overall goal of the production systems is to satisfy the growing material and intellectual needs of the population, the actual planning targets are based on the production level achieved in each sector and the need in the sectors for a specific sector's output. Thus, the resource distribution approach, as reflected in multiregional modeling, dominates in the planning process. The models do not describe the effect of final consumer's monetary demand on production, but rather they analyze the distribution among sectors and regions of natural and produced resources.

Another feature of Soviet multiregional models stems from this 'direct-distribution' approach. They are essentially physical and do not consider phenomena and behavior stimulated by monetary factors. Even when financial indicators corresponding to the financial parts of the plan are included in SMOPP-SMOTR, they reveal the direct implications of production rather than the financial and monetary mechanisms that have a feedback effect on the behavior of the production sectors.

There is a feeling among Soviet model builders and planners that traditional input-output techniques are not the most appropriate tool to be applied to small regions having a limited number of large

highly specialized enterprises. In existing multiregional models, regional characteristics in the productive sphere may be revealed only to the extent allowed by an 18 x 18 input-output model (SMOPP). It is evident that in the future more precise intraregional analytical tools should be introduced into multiregional modeling to support the economic planning system in the USSR. Integrated micro-macro modeling techniques and micro input-output models of enterprises compatible with the national economic balance seem to be warranted.

Two additional comments should be included in a discussion of the future of Soviet multiregional modeling in the context of a centralized planning system. Models applied to planning regional interactions must be multiregional because regions are explicitly included. Their problem orientation and results should also be multiregional in nature. This can be achieved only by including in model systems those models that are sharply focused on core problems and developments of specific regions, together with inter-regional flow models and national models with different levels of sectoral aggregation and different aspects. This implies that regional 'bottom-up' ad-hoc models should play a part in multiregional modeling. Such a tendency is seen in the evolution of SMOPP, the final version of which is SMOTR, in which specific interindustrial territorial complexes are modeled. Different levels of management and planning should be explicitly represented in the classification and causal links of multirecipient models. Given this requirement a multiregional model becomes a system of analysis rather than a model. Such a system of computerized modules is needed under the present system of planning through ASPR.

Some new methods of computer-based analysis must be found to integrate national and regional levels. A unique feature of the organization of economic activities in the USSR and other centrally planned economies is that all negotiations between economic units in the sphere of material production, services, finance, and credits are carried out through the agencies of the State Bank. Each economic transaction is registered there and all details of the transfer of money, the parties involved, and the subject of payment or of the accounting entry are recorded. Extensive information on economic activities in terms of flows is immediately available at

the relevant agency of the State Bank. Information on enterprise stocks is also available. Thus, in principle, it is possible to rebase economic modeling on primary information generated within the State Bank. This information may be channeled to the national and regional computerized information systems supporting national and regional planning.

It also seems reasonable to strengthen the application of national accounting principles in multiregional modeling to ensure that the models are compatible with the balance of the national economy at the macro level and with enterprise accounting at the micro level. Soviet economists are working on these problems. The possibilities offered by the State Bank's information systems for compiling integrated regional accounting systems have been investigated at the Central Economic and Mathematics Institute of the Academy of Sciences of the USSR.

4. SOME COMPARATIVE REFERENCES TO MULTIREGIONAL MODELING UNDER 'INDICATIVE PLANNING' IN FRANCE

A remarkable tool for multiregional analysis has been developed in France by Courbis and his colleagues--the REGINA model. There are also other models used in planning regional development in France.

It would be relevant to compare links between the system of planning and regional economic modeling in the USSR with those of France, not only in order to improve the understanding of existing models, but also to gain some insights from the common experience. French models are well-known in the USSR as a result of the active scientific exchange in economic modeling between the two countries.

Formalized procedures in the French planning system are based on a set of models* that includes a central real-financial model (FiFi or DMS), a model describing the international environment of France (model MOISE) and models for administration, for specific sectors, for employment, and for regional development.

*There is an extensive literature on French models. An exhaustive bibliography is contained in Sautter and Baba (1978).

For planning regional development, three types of analysis are carried out:

1. National-regional analysis. In the course of the analysis, the results of calculations based on the 'central' model are disaggregated on the basis of 21 planning regions. The analysis is focused on employment distributed according to industries and regions. No specific models are used, but time-series analysis is the principal tool.
2. Intraregional analysis. This consists in simulating development paths for each region. The SDR model (simulation of regional development model) is used to determine for each region employment, migration, and equilibrium on the labor market under exogenous constraints on production and investment activities. This model has been used in the regional-national dialog for discussing the adaptation of educational activities to satisfy the regions' needs for skilled labor and for analyzing regional housing demand.
3. Integrated national-regional analysis. The main goal of this is to reconcile developments and constraints of five large regions with the projections of development for the whole nation. The basic tool used here is the REGINA model. This model incorporates the physical-financial approach that is characteristic of the central models FiFi and DMS and contains explicit feedbacks from regions to the national level.

The integrated regional-national model REGINA has been designed for simultaneous analysis of the mutual impacts of regional constraints and developments on national socio-economic projections and vice versa. The model consists of about 8,000 equations; it operates with 6 regions within which there is differentiation according to three socio-economic zones--agricultural, medium or highly urbanized--and also according to managerial levels--zonal, regional, and national. Links within the model are not only regional-national, but also interregional (for some variables). Each economic zone is modeled on the basis

of a 10 x 10 input-output table. Links between space elements in the model relate to migration and to flows of goods between zones within regions, between a zone of one region and other regions of the country, and between a zone and the rest of the world.

The major emphasis is placed on analyzing the regional equilibrium of three markets (goods, labor, and capital), localized behavior of production units as functions of local demand, location of production factors, or situations on the market. As in FiFi, production units in REGINA are differentiated by their relation to foreign competition. The model is based on regional accounts. Parameters of the consumption function depend on the zone, thus consumption is assumed to depend on the degree of urbanization.

The fundamental features of planning systems affecting multiregional modeling (see Figure 1) are described with reference to the USSR and France in Table 2.

The main feature of the French system of economic planning is the 'indicative' character of the projections, which are binding only for the state expenditures. Plan targets are offered to independent decision-makers who are guided in their behavior by the situation on the market. The plan in France is external to economic activities, whereas in the USSR plan targets are direct commitments of enterprises to society and their fulfillment is compulsory. The plan in the USSR is the only guideline of what and how much to produce, to whom and at what prices to sell, and from where intermediate goods are to be obtained. This guidance is jointly elaborated by all participants of the reproductive process. The essentially normative character of planning models in the USSR and the descriptive character of those in France stem from this basic difference. Models developed as planning tools in the USSR reflect the strategy towards economic growth and approach to planning from use-of-resources and production-side. Models in France, including regional models, are aimed at simulating the market mechanism, with the demand for consumption and investments as factors determining the level of economic activities. As mentioned above, special attention in REGINA is given to analysis of competition among regional production units. The tendency in the USSR

Table 2. Features of regional development modeling in the USSR and France.

	USSR	France
1. Economy and role of planning	Managed by state through plans, compulsory fulfillment of targets. Predominantly administrative management. Problems of economic growth and raising living standards.	Functioning on the basis of market-mechanisms with strong regulatory functions of the state, realized through financial channels. Typical problems of industrialized capitalist economy, open to foreign competition.
2. Decision-making center	Decision-making is delegated by the state to all levels and is determined mainly by plans. Extensive system of regional decision-making centers. Independent decisions of households.	Decision-making at the level of economic units independent of state and of plans. Decision-making for regional planning limited to public sector.
3. Planning scope	Exhaustive, with main emphasis on physical aspects. Regional planning focuses mainly on the use of regional resources in national economic turnover.	Selective, changing in accordance with actual problems of socio-economic development. Emphasis on income distribution processes. Main problem is regional development equalization.
4. Time horizon	Long-term, medium-term, short-term.	Medium-term.
5. Sets of planning tasks	Very extensive.	Very limited.
6. Instruments of economic policy	All targets of plan, financial incentives, and administrative decisions.	Limited to normatives of financial nature and to direct expenditures under prerogative of the state.

to perfect models consists of further detailization rather than the introduction of new mechanisms. The main mechanism behind central directive planning is the distribution of resources in physical terms. In France, the evolution of models was determined by striving to improve understanding of market mechanisms. Therefore, separate physical models have evolved to become integrated real-financial models, through the introduction of financial and monetary phenomena in the models. REGINA has been elaborated at the stage of evolution where the FiFi model was the culminating point in economic modeling for planning purposes. The REGINA model is now being criticized for not giving sufficient attention to the flows represented in the TOF (table of financial transactions in French national accounting).

In the USSR models describe the national distribution of resources resulting from decisions about the plan. The decisions of production units are implicitly predetermined by plan targets. Only households may act independently and the planning of their activities, income, and expenditures involves behavioristic functions. In French models the behavior of economic agents in three markets (goods, labor, and capital) is the main subject of the analysis.

The difference in the planning scope of the USSR and France is also reflected in multiregional models. REGINA is actually a real-financial flow model adapted to the regional dimension. This led to the focus of attention on regional factors. In multiregional models in the USSR, the tendency is to cover all parts of the national plan, which, by definition, is exhaustive. Social processes are better reflected in Soviet models (SMOPP-SMOTR).

Both in the USSR and in France goal-oriented programs play an important role in planning regional development. But the content of programs and their status in the actual decision-making process is different. In the USSR, programs are not only projections, they are realized through a system of goal-oriented actions of the state relating not only to production activities within the region but also to institutional bodies of territorial production complexes. In France, programs are goal-oriented plans for expenditure of public funds. They are binding only for the public sector.

There are differences in modeling relating to policy variables and related technical problems. In the central directive planning system all plan targets may actually be considered as policy variables. They are tested by analyzing the response of the whole system to changes in each plan target. Therefore, no special problem of testing policy variables normally arises in multiregional modeling in the USSR. In France, where the choice of policy variables is limited by financial tools mainly, this problem is traditional for model building.

Despite fundamental differences in societal organization and in the planning and management of their national economies, France and the USSR also share many common problems of inter-regional modeling, especially with regard to the social aspects of regional development, migration, demographic processes, economic behavior of the population in different economic environments. Scientific exchange between model builders of both countries is an important factor contributing to progress in modeling multiregional interdependencies.

REFERENCES AND BIBLIOGRAPHY

- Aganbegian, A. 1963. Economic-mathematic models of prospective planning. Ph.D. Thesis, Moscow (in Russian).
- Albegov, M.M. and M.V. Golubitskaja, and D.G. Petuchov. 1975. Optimization of intraregional location of industrial production. In: Location Models of Production. Moscow: Nauka (in Russian).
- Albegov, M.M. and I. Solodilov. 1970. Problems of orientation in location of systems of industrial complexes Economics and Mathematical Methods, No. 6 (in Russian).
- Baranov, E., V. Danilov-Daniljan, and M. Zavel'ski. 1971. Theoretical and methodological aspects of optimization prospective planning. In: The Proceedings of the First Conference on Optimal Planning and Management of the National Economy. Moscow: CEMI (in Russian).
- Baranov, E. and I. Matlin. 1981. Methodological Principles of Developing a System of Models for Coordination of Sectoral and Regional Decisions. Moscow: CEMI (in Russian).
- Granberg, A.G. 1973. Optimization of Territorial Proportions of the National Economy. Moscow: Economica (in Russian).
- Granberg, A.G. (ed.) 1975. Interbranch Balances in the Analysis of Territorial Proportions in the USSR. Moscow: Nauka (in Russian).
- Granberg, A. and A. Chernyshev. 1970. Problem of territorial planning East-West. In: Izvestia. Siberian Branch of the Academy of Sciences of the USSR, No. 6 (in Russian).
- Kossov, V. 1963. Economic-mathematical model for location of production. In: Mathematical Methods and Problems of Location of Industries. Moscow: Economizdat (in Russian).
- Marjasov, V. and V. Suslov. 1980. Use of resource functions in analysis of territorial proportions. In: Research in Interindustrial Territorial Proportions. Novosibirsk (in Russian).
- Nikolaev, S.A. 1971. Interregional and Intraregional Analysis of Industrial Location. Moscow: Nauka (in Russian).
- Paseczny, L. (ed.) 1981. Comparative Analysis of Systems of Regional Planning in Separate Countries. Moscow: International Research Institute for Problems of Management.
- Sautter, Ch. and M. Baba (eds.). 1978. Les Collections de l'INSEE. La planification en France et au Japon. C 61. Paris: INSEE.
- Tsapkin, N. (ed.). 1972. Planning of the National Economy in the USSR. Moscow: Mysl (in Russian).