

# **Proceedings of the Forest Industry Workshop -- 7-11 January 1980**

**Uronen, P.**

**IIASA Collaborative Paper  
February 1981**



Uronen, P. (1981) Proceedings of the Forest Industry Workshop -- 7-11 January 1980. IIASA Collaborative Paper. Copyright © February 1981 by the author(s). <http://pure.iiasa.ac.at/1800/> All rights reserved. Permission to make digital or hard copies of all or part of this work for personal or classroom use is granted without fee provided that copies are not made or distributed for profit or commercial advantage. All copies must bear this notice and the full citation on the first page. For other purposes, to republish, to post on servers or to redistribute to lists, permission must be sought by contacting [repository@iiasa.ac.at](mailto:repository@iiasa.ac.at)

NOT FOR QUOTATION  
WITHOUT PERMISSION  
OF THE AUTHOR

PROCEEDINGS OF THE FOREST  
INDUSTRY WORKSHOP--  
7-11 JANUARY 1980

P. Uronen  
*Editor*

February 1981  
CP-81-3

*Collaborative Papers* report work which has not been performed solely at the International Institute for Applied Systems Analysis and which has received only limited review. Views or opinions expressed herein do not necessarily represent those of the Institute, its National Member Organizations, or other organizations supporting the work.

INTERNATIONAL INSTITUTE FOR APPLIED SYSTEMS ANALYSIS  
A-2361 Laxenburg, Austria

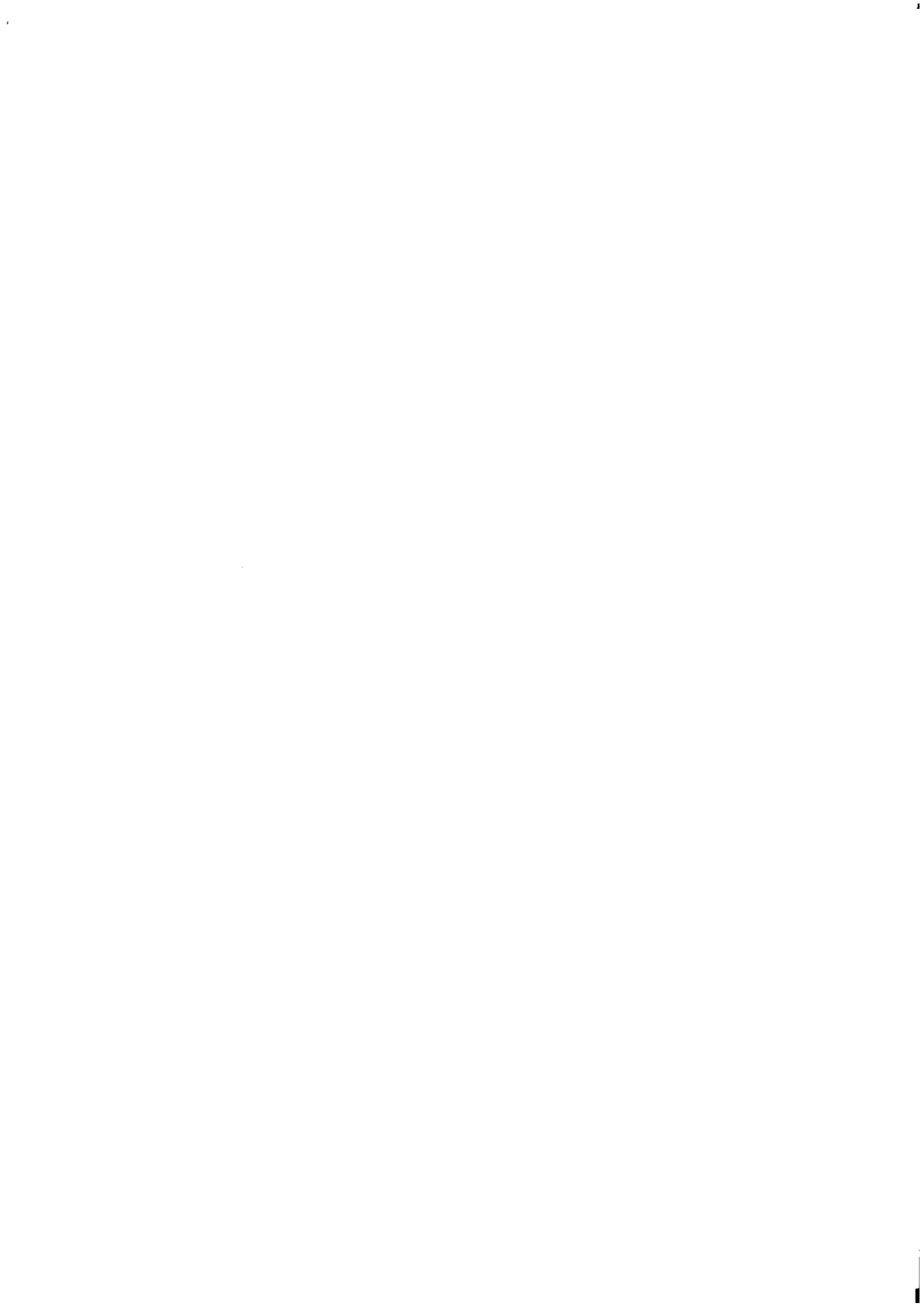

## PREFACE

The original proposal that IIASA should undertake a study in the Forest Industries was first proposed by Finnish representatives in 1978 and it was incorporated into the Research Plan for the Institute for 1979. Preparatory work was carried out during 1979 and on 8-11 January, 1980 an inaugural Workshop on these topics was held at IIASA with 40 participants from 12 countries. The countries represented in the meeting contribute about 70% of the world's total trade of Forestry products. This really was an indication of the interest in the proposed study.

This publication includes most of the material presented at this Workshop. One paper (by L. Hultkranz) was not actually presented but the text was distributed to the participants. The Appendix includes a short summary of the Workshop with the agenda, list of participants and some background material for IIASA's Forest Industry project.

The workshop supported the proposed project giving useful feedback for the continued planning and work of the project. It was also decided to publish the material of the workshop as an IIASA Collaborative Paper so as to document the work of this international meeting.

I take this opportunity of thanking all authors for their contribution to the Workshop and in this publication. It is an example of successful international collaboration.

Paavo Uronen  
MMT



## CONTENTS

### GENERAL PART:

Keynote address <i>Pentti Rautalahti</i>	2
An Overview of Important Issues Facing the Forest Products Industry in the United States <i>Peter W. Wrist</i>	5
Statement of Problems of Canadian Forest Products Industry <i>Keith M. Thompson</i>	17
Forestry and Forest Industries, Japan <i>Shinsuke T. Konari</i>	20
On the Use of Systems Analysis for the Development of the USSR Forest Sector <i>Alexander Iakunin</i>	33
Integrated Utilization of Tropical Forests <i>Detlef Noack</i>	45
Forestry and Forest Industry in Austria <i>Otto Eckmüller</i>	54
Systems Analysis in Forestry and the Forest Industry: an Overview <i>Paavo Uronen</i>	56

APPLICATION PART:

The Comparative Economics of Plantation Forestry: An Overview <i>Roger A. Sedjo</i>	88
A Model for the Forest Sector <i>Markku Kallio</i> <i>Anatoli Propoi</i> <i>Risto Seppälä</i>	101
Structural Change in the Forest Industry: A Framework of Models <i>Börje Johansson</i>	149
Wood Supply and Demand in Sweden <i>Lars Hultkrantz</i>	184
Application of Systems Analysis in U.S. Forest Service Assessments and Planning <i>Clark Row</i>	199
Spatial Integrity in Forest Planning Models <i>Dennis P. Dykstra</i>	208
Modeling Timber Supply from Private Nonindustrial Forests <i>Clark S. Binkley</i>	226
Management Systems in the Forest Industry <i>Paavo Uronen</i>	256
Methods for Production Planning in an Integrated Pulp and Paper Mill <i>Kauko Leiviskä</i>	282
Appendix	307



GENERAL PART

KEYNOTE ADDRESS

by

Mr. Pentti Rautalahti

Forest industry is a world wide industrial line based on the use of natural resources. Naturally its most important raw material is wood. The other important resource similarly important to the industry is energy. The industry uses a lot of all known forms of fuel such as oil and coal. The feature worth mentioning is that the forest industry can easier than other industries use the so called renewable natural resources as an energy source. Of course this means first of all wooden biomass. A good example of this use is a modern sulphate mill, in which the only input is wood.

The other characteristic of the industry is high capital intensiveness. Thanks to its long age the industry is also a very mature industrial area. These two factors mean that changes in the forest industry are slow. This goes for both products and the basic structure of the process.

However, continuous changes and evolution take place in numerous separate details. During a longer period of time this evolution has been almost revolutional. Good examples of the evolution in the forest industry are the improvements carried out in process control and automation. At least in Finland the forest industry has actually been the pioneer in all central applications in this field.

The first process computer in Scandinavia was installed in a Finnish paper mill as early as 1963. Operations Research applications started also in forest industry including at a very early stage comprehensive process and corporation models based on the use of computers.

Thus the forest industry has very long traditions on the use of systems analysis methods. The project that will now be launched will therefore very naturally continue the work carried out earlier.

Against the background of the development work performed in Finland it is only natural that the Finnish forest industry has taken the initiative in the project concerned. We have not, however, done so for general or purely scientific reasons. I should like to emphasize the following fact: Finland's aim is to get through this project such results as can be applied in practice and can contribute to the profitability of the industry.

It goes without saying that Finland will give its full support to this project concerned. A proof of this is that the reference organisation of the project in Finland is the Research Committee of the Central Association of the Finnish Forest Industries, which is the formal body representing the whole Finnish forest industry.

As we will now start to set targets for this project I take the liberty of suggesting the following criteria for the basis of the discussion:

1. The project and its results should be as applicable as possible and contribute to the productivity of the industry.
2. The scope of the project must be as wide as possible covering the whole process from forest to markets so that all areas of this chain are well balanced.
3. It might be advisable to stipulate the time schedule of the project as specifically as possible. The follow up of the project should be defined, e.g. in form of seminars.

Under the criteria, the following targets and results from the project are desirable:

1. Preparation of a comprehensive state-of-the-art report on system analysis methods in the forest industry: what has been done, difficulties in the application at the practical level.
2. A tool that would help the decision making within the industry in 10 to 15 years time span. The tool is not necessarily a mathematical model; a collection of statements of cause and effect, probable trends with different assumptions, etc. could also be useful to the industry.
3. The use of the above mentioned tool to analyze, how to develop material, energy, capital and human resource productivity with possible environmental and social side effects.

I should also like to express my pleasure for the decision made in favour of taking this project in the IIASA programme. I rest assured that IIASA as a multinational organization is the most suitable forum for this study. We have reasons to believe that it could not be carried out so efficiently and successfully in separate countries. An international organization is ideal for this purpose, because the forest industry itself is international. The efforts made by many countries can be combined, and surely the results from a coordinated international study could be more profound than if the research projects would be carried out separately in each country. The views and findings of both eastern and western countries can be taken into account under joint leadership. This will greatly increase the value of the study to any country concerned.

Good luck and good results to the project!

THE FOREST INDUSTRY - ISSUES FOR THE EIGHTIES

An Overview of Important Issues Facing the Forest Products Industry in the United States, by, P. E. Wrist

In considering the issues facing the U. S. forest industries during the eighties, five broad areas emerge. They are:

- Continued availability and reasonable cost of our basic raw material.
- Environmental protection in our forestry operations, manufacturing plants, and in the ultimate disposal of our products.
- Energy supply and conservation, and an increasing level of self-sufficiency.
- Increased capital efficiency, both in the use of existing assets and in the creation of future ones.
- Product specifications that more accurately reflect the performance demanded by the market's intended use requirements.

I will concentrate my remarks on these areas and would stress that I am reflecting primarily an industrial and private sector viewpoint. From a national policy viewpoint this list is clearly incomplete. Other issues, affecting forest use, arise outside the industrial sector and must be considered in an overall national forest policy. These additional issues are important factors of the national forest assessment program that has recently been undertaken by the U. S. Forest Service, about which Dr. Clark Row and others will be talking later in the program.

The Supply and Demand of our Basic Raw Material - Forests.

Any analysis of the supply/demand relationship for U. S. Forest products must take into account two important structural characteristics.

1. The very decentralized and heterogeneous nature of forest ownership.
2. The structural integration that has taken place over the past two decades between industrial enterprises in the previously separate lumber and solid wood products sectors on the one hand and those of the pulp, paper, and paperboard sectors on the other. This integration has led to increased options for optimizing resource use and greater overall utilization efficiencies.

Let me briefly talk about the diversity of ownership issues - and its relationship to a broad industry concern for increased productivity. The U. S. forest system approximately covers 740 million acres of forest land, or one-third of the land area. Of this total approximately two-thirds, or 488 million acres, are considered as suitable for "potential" use as commercial forest land. Of these potential commercial forest lands, 14 percent are owned by the forest products industry, 28 percent by state and federal governments, and 58 percent by private farmers and landowners, estimated to exceed 4 million in number.

There is a very wide range in the level of forest management practiced - both regionally and by ownership class - and also a wide range of management objectives. These differences are reflected in

forest productivity statistics. As a class, industry owned lands have the highest average productivity, 58 cu.ft. of new growth per acre per year. Other private lands average 45 cu.ft. per acre per year, and those of public (government) land average 35 cu.ft. per acre per year. These figures reflect the differing emphasis placed by the ownership groups on forest management objectives, uses, and priorities. The realizable yield of forest products from the nation's commercial forest lands is therefore influenced as much by public policy determinations and by ownership objectives as much as it is by the normal biological factors of climate, soil character, and forest type.

Let me briefly summarize the results of a major study started five years ago and just completed by the U. S. forest products industry. Anticipating the need for higher output from our commercial forests in the near future, a study was initiated to determine the existing productivity of the commercial forest lands and the potential and cost for more productive management strategies in the future. The examination was carried out for each of 25 major forest producing states, representing 83 percent of the total commercial forest lands. Within each state forest areas were categorized by forest type, soil characteristics, present productivity, and present management level. For each category the optimum productivity practices were identified from some twenty or more alternatives. These alternatives were limited to proven and acceptable management techniques. Estimates were made of the cost of changing from present to the optimum management practices, and only those which met normal industrial investment criteria were considered to be

economically practical. Improved management practices were found to be economically justified for about 28 percent of the commercial forest lands at today's prices; and further, if adopted, these improvements were estimated to increase the nation's annual growth rate by 50 percent over existing levels.

For each of the areas in which investment was economically attractive, the study identified a preferred management strategy. In many cases the change required consisted of clearing the existing stand and replanting with improved stock. In some soil classes the preferred stock required a change from hardwood to softwood forest.

The next step of this project is to consider implementation strategies. These must clearly involve consideration of social, financial, taxation, and other factors in addition to purely forestry factors. There are also transitional problems to resolve, concerned with the optimum use of cleared stock and the rate at which the conversion should occur. Developing and evaluating alternative strategies will entail quite sophisticated systems analysis, whether we are concerned with the issue nationally or on a more limited regional or even corporate level.

The second factor I mentioned is the structural change in the forest products industry itself. Historically major companies were readily characterized as primarily lumber and solid wood products producers or as pulp and paper companies. Each managed its forest resources for one or the other of these two uses. Increased demands, limited resources, and other economic factors



have forced a change over the recent past. Today the output of a forest must be used to serve a multiple of end products in order to maximize economic return. Product values are ranked, and output is allocated for maximum return. Pulpwood as such in many parts of the country has disappeared and has been replaced by lumber residuals and other residues of the harvesting process.

These changes are expected to continue, and in the future the potential use of forest biomass as a fuel source will further modify the allocation process.

The next three issue areas - Environmental, Energy Use, and Capital Efficiency in an increasingly capital intensive industry - all represent externalities whose importance has dramatically increased in the past decade. Prior to 1970 there had been very few significant changes affecting our industry for a great many years. The industry had matured and its systems and subsystems had been optimized with respect to the significant variables. As a result, most technological improvements were of an incremental nature.

During the 1970's however, we were suddenly faced with dramatic escalations in three cost sectors - environmental protection, energy, and capital construction - dramatic even when judged in relation to the inflation that occurred in nearly all cost sectors.

Fortunately, there has been one other dramatic change in the same time period of a more favorable nature, the availability of increasingly sophisticated electronic and computer based process

control and production management systems.

The impact of these four external forces has suddenly created some new and challenging opportunities for system analysis application. Because of the high degree in which the generation of wastes, energy use, and capital equipment are interrelated throughout the manufacturing processes, it is only possible to respond to significant changes in one or more of them by looking at the response of the system as a whole.

In the limited time available I will merely touch on three broad categories of problems that are of management interest and which offer opportunities for systems analysis.

A. Evaluating the economic impact of governmental environmental regulations.

Over the past five years our industry's capital expenditures have risen from an early level of 6 percent of annual expenditures on manufacturing plant to an average level of over 30 percent. In addition operating costs for the new pollution equipment have also risen dramatically. Similar cost increases have been encountered over the same time period by other basic industries such as chemicals, steel, nonferrous metals, petroleum, etc. Most government attempts to evaluate the economic impact of these regulations have essentially considered the difference between equilibrium economic scenarios before and after the imposition

of the new regulations. Unstated, however, in these analyses were the assumptions that the changes occurred without any system interactions and that they occurred at a sufficiently slow rate so that there were no significant, transient disturbances imposed on the system by the changes. To date the findings of these model studies bear little relationship to observed experience, and the result has been a wide divergence between the positions taken by government and industry on the development of environmental policy.

Although the details of environmental regulation vary from country to country, I have found wide interest in developing improved methodology for evaluating the total economic impacts of major environmental regulations. With the limited resources available to society, it is important, even in the pursuit of a socially desirable goal such as environmental protection, to seek an optimum balance between cost and benefit and between regulation and economic impact. Economic impact of a regulation is not simply measured in terms of capital investment alone but must also include such hard to define effects as accelerated obsolescence of the existing capital stock; uneven application of costs to affected plants and the dislocations this creates in the relative

competitive structure within the industry; diversion of capital from other uses such as new capacity, productivity investments, and research and development; construction and other delays caused by regulatory permit negotiations, etc., etc. The most important effects that should be of concern to the regulators are very often the interactions and the transitional impacts, which are not captured when we ignore the system dynamics.

The American experience suggests a need for more accurate economic modeling methodology for evaluating the impact of major regulatory change on an industrial economy.

B. Energy and material modeling systems for process industries.

The need to conserve energy and water use in our manufacturing processes, plus the desirability of reducing waste discharges, has focused renewed interest on the use of energy and material balances around the process. Flow balances have been used frequently to account for water use throughout a process. Today we have interest also in the flow of materials in both the solid and the solution state, as well as energy in its various forms. In the case of energy in addition to its quantity, measured, for example, in joules

or Btu's, we must also consider its quality since this determines the opportunities for re-use within the system.

A number of computer based systems have been developed for system optimization such as GEMS, ASPEN, and one developed by Paprican. These models depend very heavily on empirically derived inputs and are not very adaptive for energy related problems. Improved techniques are certainly needed. Typical problems being faced include:

- estimation of equilibrium levels of solute buildup in partially closed systems. Many materials normally present only in trace amounts can eventually build up in closed systems to levels which create severe corrosion problems.
- whole tree chipping presents operating problems in the mill and the need for system changes to eliminate undesirable contaminants such as bark and grit. The options of how and where to do this in the system are many - in the woods, woodyard, digester, bleach plant, or paper mill. Selecting between these many options, which involve different technologies and trade-offs between energy and chemical use,

etc., makes a system analysis approach essential.

- wood may be used interchangeably as a fibre raw material or as a source of fuel. The option between the alternative uses occurs at several stages throughout the process. Again, economic optimization of the manufacturing process requires a systems analysis approach.

C. Process and Production Management Control.

A large number of minicomputer based control systems are now available and in use on almost every unit process within the manufacturing process. We are now facing the challenge of integrating these subsystems into a total process and production management control system - with hierarchial levels of integration and supervision.

Problems that have been encountered include -

- (1) training of qualified personnel within the mills to run and maintain systems after they are installed by the experts.
- (2) analysis of benefits before an investment decision is made. Decisions are frequently made on faith and justified (or not) retroactively. In the case of new facilities the decision is often

one of expediency to recognize the lack of experienced labor.

To date many systems have merely automated existing operator strategies with benefits limited to those of eliminating operator error or neglect. We are only just beginning to exploit the benefits of using the ability of computers to use other more advanced control strategies. For example, initial control systems for recovery boilers automated normal operator strategies. Reliability improved, but steam flow stability did not improve because of uncontrolled variations in heat value of the black liquor, which arise from variations in the raw materials and the pulping process. Second generation controls which use residual oxygen levels in the flue gas as a surrogate for heat release are now in use, and these have made stable steam flow possible. Further improvement in control strategies, based on fundamental knowledge about our systems rather than the automation of the empirical methods used in the past, offer the potential for an increased level of economic benefits.

In closing I will only mention by title another opportunity for systems analysis - that of identifying the critical properties required of our products in their use in the marketplace system.

For example, corrugated cases are a major end product of our industry, but their function in the economy is to protect goods in the distribution system. Ignorance of the critical performance requirements encountered during actual use has often led to overdesign of our products to avoid costly failure in use. This overdesign often, however, represents a potential waste of raw materials. Systems approaches to improve product specifications are now being made by a number of investigators.

Likewise, printing paper and communication papers are used as components in other consumer systems, and the performance requirements and, indeed their continued use, will depend to a large degree on how the needs placed on these systems change in the future.

In his opening remarks Dr. Tomlinson mentioned the interest of IIASA in the systematic study of the innovation process. I have talked of many major changes taking place in our industry. Historically, the industry has become mature, heavily capital intensive with slow turnover of capital stock, and, therefore, biased to slow change. Managing changes of the magnitude we have been discussing calls for innovative approaches, and I am sure we will be interested in any advice or methodology that IIASA can offer for stimulating innovative change within industry.



STATEMENT OF PROBLEMS OF CANADIAN FOREST PRODUCTS INDUSTRY

The statement of Dr. K.M. Thompson, acting on behalf of Pierre R. Gendron, on the problems of the Canadian forest products industry was based on the June 1978 report of the Forest Products Industry Consultative Task Force, chaired by Ian A. Barclay. It was prepared after discussion with the other Canadian participants but the author takes full responsibility for the contents.

In his remarks, Dr. Thompson pointed out that other studies such as "Review of the Canadian Forest Products Industry", ITC-Canada, November 1978, and "The Outlook for Timber Utilization in Canada to the year 2000", by K.L. Aird and J. Ottens, Canadian Forestry Service, July 1979, should also be consulted by those wishing a more detailed view of the industry.

1. General Problems

The concerns of the Canadian forest products industry is largely in four areas: the cost disadvantages relative to its competitors in the United States, the investment climate relative to the United States, the difficulties in generating adequate capital, and the maintenance of the forest resource. These broad concerns are expressed more specifically under nine headings.

2. Specific Problems

a. Investment, Modernization and Taxation

Among points to consider under this heading is that the industry is a cyclical one with very high capital needs. Although the industry is at present earning large profits these are the result of three factors: a strong demand for its goods, an exceptionally high operating rate due to lack of investment in recent years, and a favorable exchange rate. The first and third of these factors could change quickly due to events outside the industry, and the second could change due to investments resulting from the current profits. Thus, a period of prosperity is in general only one part of the cycle.

Other points that should be considered by anyone doing a systems analysis of the industry are its regional character, the structural changes needed due to the introduction of new technology, for example in saw milling, and the effect of changing policies of taxation.

b. Forest Resource and Management

Although Canada is now cutting only about two-thirds of its allowable annual cost as presently defined, it appears that the entire supply of wood will be needed by 1990-2000. Wood costs are already of concern, and it is recognized that the remaining third of the wood supply can only be obtained at a much higher cost.

Canada is faced with the challenge of converting from the exploitation of its forests to the management of this resource. Any system studies dealing with this situation would be very helpful. Points to consider in this are that much of the forest is crown land administered by the provinces. Methods of payment for forestry are worth attention, as are the use of different species and pressure on the forest as a source of fuel. Analysis of timber growth and supply is a major topic for systems analysis in the Canadian view.

c. Environmental Control and Pollution Abatement

Pollution abatement with its accompanying high capital requirements is of considerable concern. The newsprint industry with its large number of small sulphite pulp mills is a special case in point. Systems analysis of environmental control, the basic reasons for it, its effect on capital flows and other resource industries such as fishing and tourism would be of interest.

d. Energy

Energy costs are very important to the industry. It should be noted that the form of energy required must be considered. For example, the production of newsprint requires a great deal of electrical power for the manufacture of mechanical pulp. Technical trends, such as the introduction of thermomechanical pulp, can increase the requirements of electrical energy. On the other hand much of the electricity used in the Canadian industry is generated from water power and as a result the extra cost in electricity is often more than offset by savings in wood cost. The degree of offset varies from region to region.

Studies of mill operation to reduce energy needs are underway, as are studies of the trade-offs between fibre and fuel. Further systems analysis in these areas would be welcome.

e. Transportation

Transportation is of importance to the industry because it represents a significant percentage of the delivered cost of the product. In addition it is important to the country as a whole because transportation of forest products is the largest single source of revenue for Canadian railways. A factor that may or may not be unique to Canada is that legislated freight rates on another commodity, in Canada's case grain, are in part subsidized by the forest industry.

f. Research

It is generally recognized that, although research and development is essential in order to improve the competitiveness and productivity of the forest products sector, the research effort related directly to the forest industry is small as compared with the industry's major competitors.

Systems analyses which would be of great interest include a study of the effectiveness of different financial incentives for research, and the choice of areas of research and development which will have the greatest impact.

g. Market Development

There is clearly a need for more reliable forecasts of the demand for forest products. In this connection, the relation of demand with gross national product appears to have changed in recent years. Studies of the world market for forest products and the linkages with the national economies have perhaps the highest priority for Canada.

Under the same heading the effects of tariff policy and changes in the exchange rate are of great concern. Also, the development of new technology such as the recent developments in electronic communication could have a great impact.

#### h. Competition Policy

This is related to tariff policy which was referred to under the heading of market development. It is referred to here because studies of the effect of different competition legislation would be of great interest.

#### i. Labour/Management Relations, Unemployment Insurance, and Manpower

The labour cost disadvantage of the Canadian forest products industry relative to the United States industry, due to lower productivity and higher wages is of concern. There is a regional dimension to this problem, both with regard to the problems of attracting labour to remote areas and the dependence of small towns on a single, forest industry establishment.

With regard to systems analyses it is noteworthy that one recommendation of the task force was the appointment of a group of economic advisers with specific expertise in the forest products industry to produce short-term and long-term economic forecasts and analyses of current economic matters relating to the industry.

### 3. Conclusion

In conclusion it was stated that the Canadian forest products industry needs an improved ability to:

- a. compete
- b. attract new investment, and
- c. share in serving the future growth in world requirements for forest products.

It was felt that applied systems analysis could be of great help in providing this ability.



FORESTRY & FOREST INDUSTRIES,  
JAPAN

Shinsuke T. Konari

Japan has a book edited in 720 and titled Nihon-Shoki or Chronicle of Japan which tells the story of ancient Japan from its pre-historic times. We read in this book a lovely story. It is about a god of predominant role in our mythology who, together with his sister goddess, designed the life of people living on this land. It goes--- the god pulled out some of his moustache and chest hairs, strewed them about on the soil, and whereupon sprang up and grew cypress, cedar and maki(*podocarpul macrophyllus*). The god then taught people to use cypress for building palace, cedar for ship, and maki for making coffin --. This cypress is very high tree of our particular species.

Traditionally, Japan has been the land of wooden construction, and for this reason, many of its old structures of great historical values have been lost by fires never to be seen. But, we can imagine the splendour of our earlier days' wooden structures from what have been left safe to this day. It is impressive to see that cypress lumbers have lived for the past 1,300 years supporting heavy constructions. These cypress had lived well over 1,000 years on the soil before they were cut, and thus another 1,300 years supporting and forming grand and high-rising buildings with almost the same strength as that of newly logged ones.

Incidentally, our skilled carpenters used lumbers cleverly. When a tree trunk was split into quarter, they applied the south quarter of the trunk to form the sunny side, and when a trunk is of a tree growing on the northern side of a mountain, to form a shady part of a building. This way, the lumbers could live in their harmonious biological placement.

Such craftsmanship and philosophy is gone today. We talk about changes of life joking on those undisciplined builders who ignore the top and the down of a piece of lumber.

We must leave emotion and esthetic perhaps. Our economy today is consuming a large quantity of wood as elsewhere in the advanced economies, and to live up to the requirements today and future, we are being forced to grapple with the knotty problems of how to best grow, utilize and sustain wood resources, and at the same time, of how to most logically import what is short in our domestic wood supply.

Vis-a-vis today's actualities, the position Japan is placed in would be regarded as a pivot of possible developments in the world wood/fibre demand-supply picture.

#### \*\* FOREST RESOURCE, JAPAN

Coming to the subject of this gathering, I begin with an explanation on our general situation.

Japan's woodland covers a little over 25 million hectares occupying 68 % of its whole land space, of which, roughly one third is national forest and the rest privately owned. Also, the total timber stock, calculated at 2.1 billion m<sup>3</sup> at present, is divided into 56 % softwood and 44 % hardwood. Japan originally was a hardwood land or laurilignosa zone which extends arcuately from south China and north Indochina. Suda-Jii or pasania is the ultimate phase of plant life transition in Japan's central open fields.

In the past years, while overcutting, we launched extensive reforestation activities which now is recorded at 9.4 million hectares with 800 million m<sup>3</sup> in stock representing 37 % of our whole timber stock. These reforestations are almost 100 % softwood, their major species being cedar, cypress and pine.

Back in 1960s, Japan's timber stock was down at 1.9 billion m<sup>3</sup>. With restrained cutting thereafter and active reforestation continued, it has increased to 2.1 billion as above quoted, and will continue to grow to somewhere between 2.5 and 3.0 billion in the future. At present, 82 % of these reforestations are young and under 25 years age class staying behind production front yet. This is one of the structural features of Japan's forest resource today.

Wood felling in the past 25 years ranged 115 to 150 m<sup>3</sup>/hectare, and we felled 80 million m<sup>3</sup> in a peak year in the overcutting 60s. Our current annual felling of 44 million represent 2 % of the total stock of

Figure-1

WORLD WOOD FELLING incl. FUELWOOD

--source: Yearbook of Forest Products, FAO

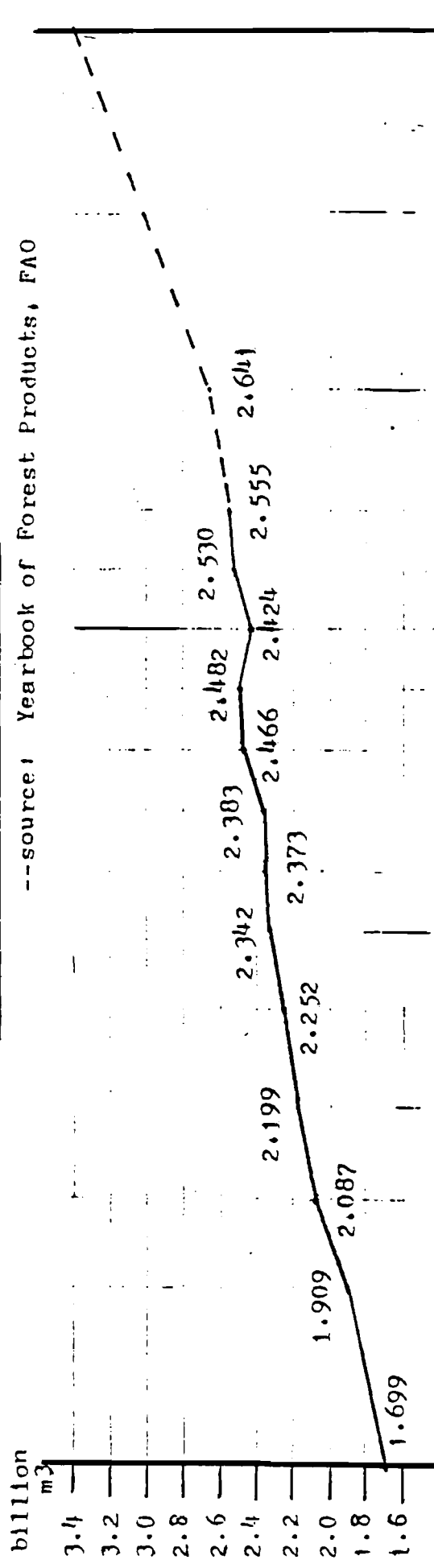

DOMESTIC LOG SUPPLY & LOG/FIBRE IMPORT, JAPAN

--source: Forestry Agency, Japan

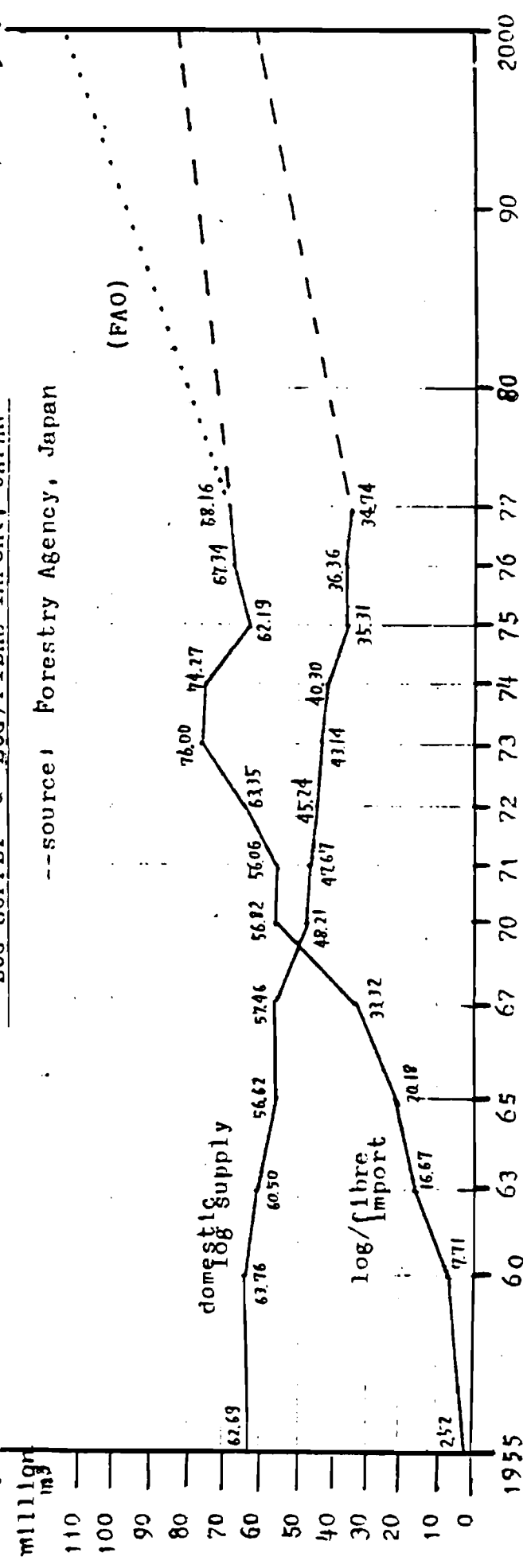
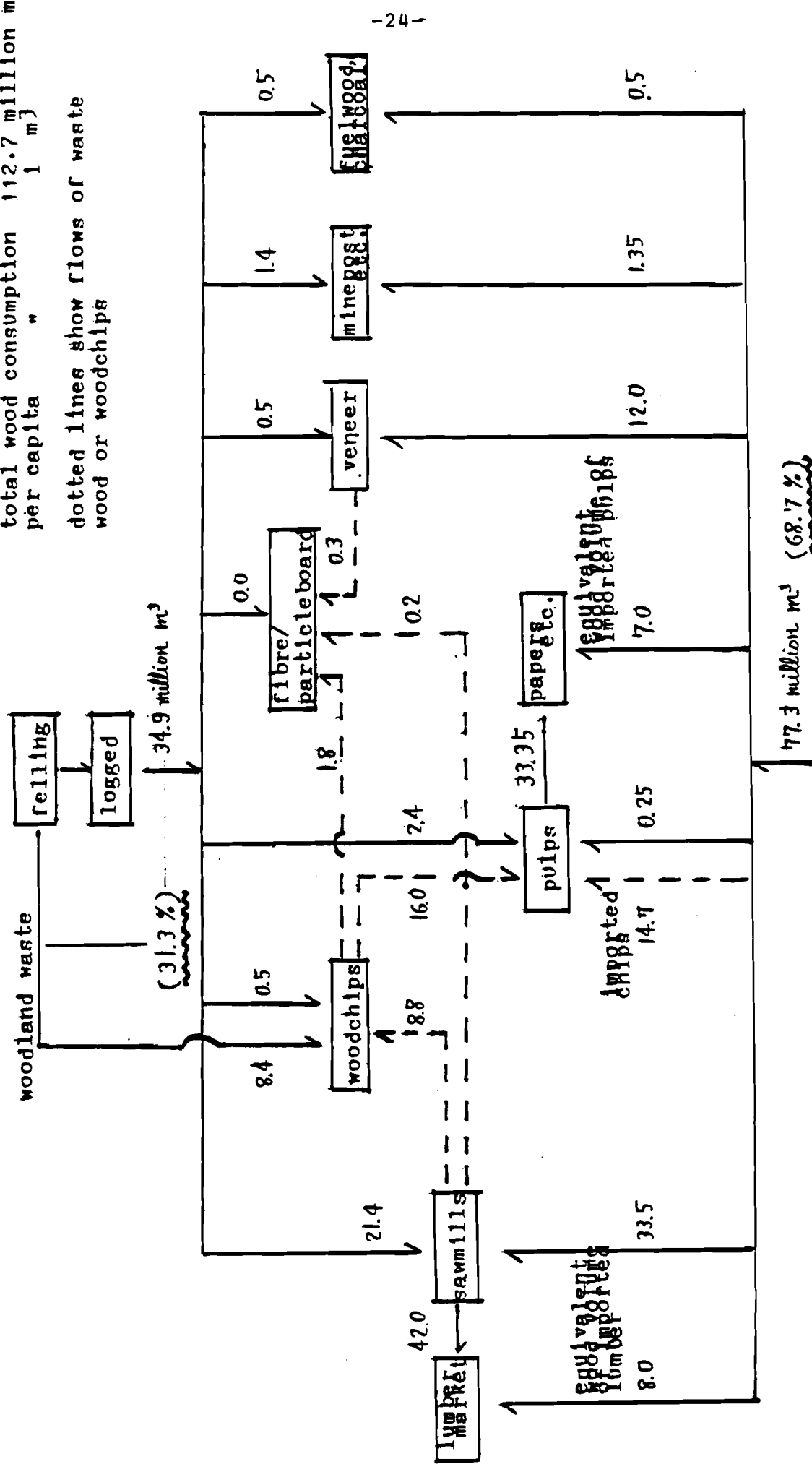

Figure-2

WOOD SUPPLY & DISTRIBUTION -- '78/'79 average

-- DOMESTIC --

total wood consumption 112.7 million m<sup>3</sup>  
 per capita " 1 m<sup>3</sup>  
 dotted lines show flows of waste  
 wood or woodchips



-- IMPORTED --



2.1 billion m<sup>3</sup>. Against this, according to the governmental sources, the softwood reforestations are to show the average 5 m<sup>3</sup>/hectare yearly growth with cedar substantially higher and pine/larch lower than the said average growth. Hence, the standard cutting cycle of 40 years would yield 200 m<sup>3</sup>/hectare when matured. Or, if 2.5 % up yearly growth is to be assumed, 2.8 billion m<sup>3</sup> of productive timber stock would balance with yearly felling of 70 million m<sup>3</sup>. A recent FAO publication indicates that Japan's wood production will be definitely for the increase though with a diminishing share for hardwood.

**\*\* USAGE DISTRIBUTION AND PER CAPITA CONSUMPTION**

Shown in Figure-1 is year to year transition of Japan's domestic log production as well as its wood import including equivalent wood volumes of imported pulps and other forest products.

As seen here, the import came to top the domestic supply in 1969. The current yearly import is ranging around 70 million m<sup>3</sup>, of which log alone amounts to 45 million representing one half of the world total log trade. Our major log suppliers overseas are; Southeast Asia with 22 million for one half of Japan's total log import followed by US's 12 million and USSR's 9 million m<sup>3</sup>.

No less outstanding than this heavy log trade is Japan's massive wood-chips import which is presumed to have been somewhere between 14 and 15 million m<sup>3</sup> in 1979. The actuals for 1978 were;

US	N-chip	7 million m <sup>3</sup>	Australian	L-chip	2.7
USSR	"	0.7	SE Asian	"	0.8
NZ	"	0.4			
					TTL incl. others
					13.3

Our wood distribution by industries is shown in Figure-2 where the following points will be noted:

- 1). Unit yield for lumber at sawmills stands at around 75 % which compares favourably with North American 50 %. Different log size and close utilization practice naturally influence on the unit yield.
- 2). Recovery rate of waste wood, close to 50 %, is apparently higher than the world average.
- 3). On the surface, woodchips import dependency rate for pulp making stands in 45 % range. However, when domestic waste wood-chips supply is traced back to their origins, the real import dependency

is known to be close to 70 %. Many of our sawmills are operating on imported logs.

4). The least dependent on overseas wood supply are fibre/particle board industry.

5). Veneer production is 95 % dependent on wood import from SE Asia which, however, appears to be decisively for the decrease in the near future. Also, the cost competitiveness would be questioned here.

Else, fuelwood now takes only a slight portion. Fuelwood once amounted to 30 million m<sup>3</sup>. However, marked demand-shift had occurred with the progress of the oil age, and, fortunate for paper industry, this fuelwood resource offered itself as an additional fibre supply source for the expanding pulp production.

Now with paper industry, Japan's paper industry has passed three turning points to this day.

Firstly, penned in relatively small islands after the war, the industry exerted desperately in 50s to make use of the then unutilized hardwood resource--beach, birch, oak and the like. Japan in this field could be regarded as a world pioneer.

Secondly, in 60s, the industry could recourse to the then idle fuelwood resource which helped expand domestic pulp production greatly.

Thirdly, in 70s, the industry exploited and expanded new wood supply channels with ocean-hauled chip import using exclusive vessels, which now shares some 45 % of the total fibre furnish to the industry (excl. recycled papers furnish).

Again, as seen in Figure-2, Japan's per capita wood consumption stays in the neighbourhood of 1 m<sup>3</sup>. It was in 0.75 m<sup>3</sup> range in 60s which would be comparable to the present day West European niveau. The consumption had shown gradual increase till it marked 1 m<sup>3</sup> in 1970. Thence on, it has been fluctuating between 0.9 and 1.1 m<sup>3</sup> following the movement of the general business cycle, i. e., the trend has been tending to level off in 1 m<sup>3</sup> range.

What in future then ? My feeling is that, even with continued economic growth permitted, it would rather be doubtful to expect the per capita consumption to rise over 1.2 m<sup>3</sup>. Overall wood availability, long-term estimates of housing start, lumber consumption per house building, wood cost competitiveness vis-a-vis other building materials, paper consumption trend and other factors all combined seems to me to

indicate to this modest movement in the future.

## \*\* PROBLEMATICS IMPLICIT

As seen in the above, Japan is heavily involved in the world wood trade both to support itself and to give impetus to the wood-exporting economies. Today, in the face of the increasing tension over the availability of the world wood resources and craving for further possibilities in the wood/fibre economies, Japan would have not a few things to tackle with by itself in the first place. Shortly in the following, I will give some of its problematics.

### \* FUTURE WOOD IMPORT

Notwithstanding the increasing domestic supply, Japan will have to look for the continued import on the modest increase toward future. However, from the indications overseas, Japan's present pattern of the import seems doomed to undergo some alteration.

#### -SOFTWOOD-

East Siberia, the richest softwood resource remaining in the world, naturally is the first-hand factor both for USSR and for Japan or for the whole East Asia, though the productivity there would have to be well managed.

Softwood log import from Pacific US might have its problems toward future ( a partial replacement of US log by North American lumber thinkable as a possibility ).

New Zealand reportedly would have to wait for the second growth to expand its softwood felling. Increased softwood supply to Japan from Oceania may be expected in the long run.

SE Asian as well as Chilean softwood could hopefully meet the future need of Japan.

By the way, in Japan's house building, US log has been used for foundation and pillar. USSR log has been for beam and rafter, and SE Asian log for board(35 %) and veneer. While, our domestic wood is generally of higher grade and somewhat expensive for all purposes. The traditional housing specifications are yet widely observed in Japan, being better fit for the climate and the life style. The traditional ones are more wood-saving and thus less expensive in overall building costs at present.

-HARDWOOD-

The industrial hardwood species Japan is now importing from SE Asia are becoming increasingly scarce items. Lauan (Shorea and Parashorea), for example, is feared to be exhausted in less than 10 years if the current rate of felling be continued. This is noticeable in Sava and Sarawak. Also, the movement of SEALPA (SE Asia Lumber Producers Assn.) should play an influence.

SEAsian plantations are presumed to be for fibre grade rather than for quality sawmilling. Hitherto unused hardwood species, if exploited, would also include fibre grade.

Oceania could remain Japan's stable hardwood trade partner. But, much could depend on Japan's actual need and its approach to this area if the trade volume is to be sizably increased.

In this connection, and particularly in SE Asia, there would be ever stronger local aspiration for certain processings of the material log and for Japanese funding and assistance for this purpose. Some one half of SE Asian wood felling would be at any event for export regardless of their exporting forms. All these reasonabilities should be questioned in the light of global economy and economical efficiency.

\* PRICE FORMATION

The price relation between soft- and hardwood as well as between domestic and overseas supply will be keys to form the future demand-supply order and the trade pattern.

For one thing, it is often pointed out in Japan that, if the import should decrease, more of domestic thinning would be offered to the market, and that, should the price hike too rapidly, the consumption would naturally be kept down or replaced by other construction materials. Also on the other hand, it appears admittable to surmise that there may be a room for future wood price to move at a bit higher scale than the movement of the general wholesale prices in order to reach at a stable relative price and demand-supply equilibrium. In Japan, wood growers' costs are not being fully compensated at present.

Looking back on the past domestic situation, the scarcity of woodworkers, the deeper interior operation with Japan's adversely mountaineous topography and lack of well-organized woodroad networks have been among the causes of the decreased yet expensive wood shipment. A greater part of our woodworkers have been working on by-work. However, sizeable investments are and will be made for woodroad preparation, and recent social life seems to tell that woodworkers

would be procured only if their wages be assured on all-year employment basis or otherwise.

\* PAPER INDUSTRY

Again particularly on our paper industry which is my field. Paper and paperboard production for the business year 1979 (Apr. to next Mar.) is currently estimated at 17.9 million tons (7.7% increase over the previous business year) against the estimated domestic demand of 17.7 million tons. The corresponding woodpulp production including dissolving grade is estimated at 10.2 million tons. Some 1.8 million tons of pulp was imported. For the domestic woodpulp production, the average wood input has been relatively stable at 3.3 m<sup>3</sup> per one AD ton of pulp (50% hardwood furnish).

The Japan Pulp and Paper Research Institute filed last fall a future demand forecast collected by employing Delphi method. According to the file, 25 million tons niveau paper consumption is expected to come around 1993-94. If so, it will be translated to 2.7%/p.a. increase. The mean of the responses for a probable time of 200 kg per capita paper consumption was for 1995, which again can be translated to 2.8%/p.a. growth with an available population transition estimate in consideration.

The above can be compared to Japan's 9.1%/p.a. growth recorded in the past 20 years and the world's 5.4%/p.a. growth in the past 30 years. This mild growth will still be higher than the earlier said conservative wood consumption estimate.

Though Japan is rich in its economic data, forecasts made by usual regression, whatever the employed historical materials, tend to produce unacceptably big values for the future. Curvilinear expression, like logistic curve, also does not appear to fit so well because of the recent vigorous performance of Japanese economy.

The above growth estimate apparently has considered on wood, water, land and energy supplies and waste paper recovery limitation on the one hand, and on changing life mode and economic setup on the other. There are not a few people who estimate even under 2%/p.a. growth toward 2000.

Note: -Japan's population estimate is now under review with the late tendency for lesser birth rate.

If such be the case, the present industrial structure and the trade pattern might be sustained wholly or for a greater part into the future, subject to non-occurrence of any grave disturbance in the overseas wood supply and in the international price relation.

Whatever the coming situation, however, there are observed several points of concern now prevailing in the industry, and some of which with apparent reasons and some possibly a bit overstated.

These are:

- 1). possible difficulties of wood import,
- 2). desire for local wood processing in the exporting countries,
- 3). scarcity of additional mill-sites in Japan,
- 4). shortage in additional water supply in Japan, and
- 5). possible deterioration in the competitiveness of domestic pulp production.

Certainly, wood import situation may be a delicate one. There would be ever stronger aspiration for local pulp production in the wood exporting countries. But a modern pulpmill construction requires a huge amount of investment. Where comes the necessary fund and the software from ? As said elsewhere in this report, SE Asia, USSR and Oceania will be among the areas of the challenging themes for the industry.

Speaking of SE Asia, it is feared that any single Japanese company of any single industry would not construct and operate a big modern mill without difficulty, and this could apply for a pulpmill too. Hence, it would naturally be studied to build there modest-sized industrial complexes of , say, power, metal, cement and forest products. Thus, energy, technologies, supplies, port facilities, work force, education and the rest could supplement each other component of the complex activities, and enhance the labour quality and the local living conditions as a whole. So, a multi-industry consortium might be a key to developing the area.

In another angle, it might also be worthwhile to study on the feasibility of semi-processed crude pulp production; or on the feasibility of sugar-cane or sugar-cane/wood complex for production and export of bagasse or bagasse/woodpulp, fuel alcohol and others, finding means to all-year bagasse feed and anti-fermentation.

While with Japan itself, the major question will be what form of import would be the optimum for the industry to fill shortage in the fibre furnish in the future.

Woodchips import made to this day has its strong points in;

- 1). utilization of Japan's rich tidewater location,
- 2). utilization of the accumulated capital stock,
- 3). savings in the total construction and operation costs,
- 4). economy and flexibility of the rationalized integrated operation,
- 5). stabilized material flow (important) and so forth.

Save wood cost, the manufacturing seems less expensive and more efficient in Japan. On top of these, the manufacturing is done just amidst the huge consuming market.

Only, the ocean freightage for woodchip transportation tends to become more disadvantageously costly than that for pulp and paper. Anyhow, being heavily dependent on waterbourn transportation, big mills of the industry will be more concentrated on litoral locations as they actually have been in the past.

About availability of additional mill-sites, our survey shows that there are more of the available land spaces than generally thought. A closer limitation rather seems to be the availability of additional water supply which would allow only for 15 to 20 % fresh water supply increase under the presently available techniques of water utilization. However, this allowance can be translated to more than 50 % additional water availability when recycled.

Certainly things cannot be decided on only from seperate physical possibilities, and changing structure, if it should change, of the whole national economy and of the paper industry could act on each other's future formation. In this connection, price relation or relative prices will be among the decisive factors. How could we set off our handicaps with our diligence and our high-tension productive society ?

I have not done any study worth introducing on this serious question. I only did a fragmental and simple check on the past performance of the woodchips price relation as follows.

$$C_d = k T_d^a C_m^b S_m^c \quad \begin{array}{l} \text{exponent a} = 0.374 \\ \text{'' b} = 0.053 \\ \text{'' c} = -0.639 \end{array}$$

where:  $C_d$  = domestic woodchip price index  
 $k$  = constant  
 $T_d$  = domestic wood quotation (construction grade)  
 $C_m$  = imported woodchip price index  
 $S_m$  = import ratio in the total woodchip supply  
--- calculation made on the past 12 years series.

Domestic woodchip price has been formed under the greater influence of domestic wood market quotation than that of woodchip import price, but it has had the greatest exponent on the woodchip import ratio. It should be noted in this regard that log and woodchip imports have both been on the increase during this period thus affecting on our wood market -- log, lumber, woodchip and others all inclusive.

Also, with bleached sulphate pulp, wood cost has been on 40s % of the total manufacturing cost, which would be comparable to the Scandinavian counterpart but is definitely higher than the North American and Brazyliaian 20s %. Here, the difference between 20s and 40s % might be construed as applicable for the portion which counterbalance unstable and thus possibly expensive manufacturing and long-distance transportation costs to Japan of overseas pulp production. I wonder if such is not of some indication. Very simply to justify Japan's pulp production with imported woodchips;

$$M_d = (T_2 - T_1) + M_o + \alpha$$

where:  $M_d$  = domestic pulp manufacturing cost

$T_2$  = ocean freightage for pulp

$T_1$  = ocean freightage for woodchip

$M_o$  = overseas pulp manufacturing cost

$\alpha$  = additional costs and unstable elements which may be involved in overseas pulp

If I may further add, the cash coefficient ( total fund input versus total added values ) for our paper industry has been around 3 subject to slight fructuation caused by Japan's business climate, an indication of fund requirement for pulp and paper mill operation in Japan.

I hope I so far could give something of Japan's wood situation and its problematics today toward future.



ON THE USE OF SYSTEM ANALYSIS  
FOR THE DEVELOPMENT OF THE USSR FOREST SECTOR.

Dr. Alexandr Iakunin

The USSR leads the world in the size of its forested area, in its timber resources and in the volume of timber cut. The timber and woodworking industry plays an important role in the country's economy. The annual volume of timber harvested amounts to about 400 million cubic metres, the output of sawn timber amounts to 100 million cubic metres and the annual chipboard and fibre-board production runs to 5 million and 500 million square metres (correspondingly). It is common knowledge that logging industry (as an extractive one) is considered to be the basis for forest and woodworking industry development. Nowadays, the soviet timber industry potential means more than a thousand of modern wood producing enterprises, well-equipped with up-to-date machinery.

A distinguishing feature of scientific and technological progress in the industry is the trend for comprehensive mechanization of all the processes with the aim of full exclusion of manual operations. Every process is carried through by a special set of machines and equipment. At present, cutting and logging operations as well as transportation are fully mechanized: it means that an operator does not come into close contact with a tree or a log by himself. A number of new machines and mechanisms for the mechanization of such operations as logging, skidding, timber transportation have been recently developed.

In practice the development and utilization of new systems

of machines appears to be rather complicated problem from both points of view: scientific and technology, as well as socially. The system is to meet the following requirement: to increase the volume of harvested timber without any damaging expansion of timber cutting areas with taking account the problems of subsequent reforestation and forest protection.

Besides, the climate conditions are quite different throughout the country. New systems of machines are characterised by their great complexity so the operation and maintenance of them will require high level of professional training of all those engaged in the process. Here comes the necessity to raise the level of workers' professional training, as well as to develop new methods of production management. One more problem presents interest in this connection: social consequences after introduction of new systems of machines: specific changes in labour, reputation of any forest profession, worker's age etc. Despite the large areas covered with forests, the soviet government is subsequently keeping the line to supply the country with large amount of timber on account of more rational utilization of a tree biomass without any damaging expansion of timber cutting areas. This task is being fulfilled by complete use of woodwastes as well as by increasing the output of final products on the basis of low-quality wood and secondary raw materials such as sawdust, chip, shavings etc.

Despite the latest increased volume of fibreboard, chipboard and technological chip production, still the larger portion of a tree biomass is not fully used so far.

It is conceived that profound systems analysis of present situation and future development in biomass and low-grade wood utilization as well as information exchange on this matter between National Member Organizations (NMO) might be of great usefulness.

According to economists' estimation, by 2000 year wood consumption will account to 4-4,5 billion cubic metres. In this connection it becomes necessary to develop structural models on consumption and production of raw wood materials which can be used for long-term development of forest sector. Besides, due to increasing demand for wood products in future the problem of rational intergration of forest exploitation and silviculture is becoming more and more acute. Here there some questions which require proper systems analysis and economic background: what optimal period of felling cycle should be determined in order to minimize the damage from ecological point of view but at the same time to increase the volume of timber harvested; what the optimal organizational structure of wood industrial enterprises should be adopted; what methods of plantation management should be considered the best ones; and some other questions.

An important task in forecasting the development of forest sector is to solve the problem of optimal forms of integration of forest exploitation and silviculture on the basis of systems analysis.

And it would be advisable to include this item into IIASA research plan.

The woodworking industry like other branches of forest sector has made substantial technological progress over the last few years. The steady high rate of production volume is due to the mass-scale modernization and reconstruction of the wood working plants.

Besides, forward-looking technological processes are being introduced at a large number of woodworking enterprises throughout the country. In 70-s great emphasis is being made on chipboard and fibreboard production which results in more efficient utilization of tree biomass (up to 92-93%) as a means of solving the problem of more rational utilization of raw wood materials.

At present, a large number of factories specialized in chip- and fiberboard production have been constructed and put into operation. Their production capacity ranges from 110 thous. cub. m. up to 250 thous. cub. m. The forest industry increases furniture production at a high rate; during the period of the last eight years volume of furniture production has been increased by 2,2 times.

The introduction of specialized high-capacity complete plants and the use of chemicals result in a steady growth of furniture output. Fast scientific and technological progress plus organizational methods (concentration, process and object specialization) will enable to increase average capacity of furniture plants by 31, 2 per cent as compared with 1975.

Nowadays strong efforts are being taken to increase the volume in output of prefabricated wooden house building. Towards the end of the current five-year period the enterprises are to increase the output of prefabricated wood<sup>en</sup> houses by many times on the basis of concentration and specialization of production as well as by using modern building materials and new highly efficient<sup>i</sup> machinery and equipment.

As a whole woodworking industry at present includes thousands of enterprises of different capacities: there are some woodworking plants of comparatively small production capacity (up to 0,5- 1,0 thous. cub. m. of raw wood processed per day). At the same time there is a gigantic wood industrial complex such as Bratsk industrial complex, the daily output of which accounts to 20 thous. cub. m. Besides the introduction of new techniques the main problem to be solved within the woodworking industry is to determine the optimal forms of concentration, specialization as well as of integration. As far as these forms are concerned, it should be beared in mind the most important factors upon which the scale and location of

industrial enterprises depend. Among them are the following:

- natural and economical conditions of each region;
- labour and raw material resources;
- transportation conditions etc.

This task is very complicated, that is why it requires profound systems analysis.

The soviet economy developes according to the planning system thus the developing of planning horizon for a long period of time is of special importance for our country. On the basis of a dynamic linear programming we have developed optim<sup>i</sup>sational model by which we can solve the problem of how to produce maximum amount of final products ( such as sawn timber, panels, furnit<sup>u</sup>re etc.) at the least cost and maximum economy in capital investments.

Alternately the situation in the country is this that the manufact<sup>u</sup>ring of the same forest product in different regions of our country may result in saving production and transportation cost , but at the same time the situation may require additional capital investments on creating ifrastructure.

The presented model gives the possibility to develop alternatives and choose the optimal solution. The concept of the model is to minimize total annual cost and capital cost for production and transportation of raw wood and final products, as well as to utilize tree biomass at a maximum level. As any other model , the presented one has I9 inputs and I2 constraints. Here there are some of them ( the basic ones) :

- I. the volume of forest harvested should not exceed the upper limits of cutting ares;
2. production and distribution of raw wood materials, as well as production and distribution of intermediate and final products should be balanced in the proper way and with respect to;

1. wood assortment by species and size;
2. sawn timber and plywood by types;
3. furniture, prefabrikated wooden houses, matches etc.;
4. fireboard and chipboard;
5. woodwastes of harvesting and woodworking processes.

Because of the necessity to take into considerations the total annual cost and capital cost in different periods of time, we are to reduce mentioned factors to the total cost on the unified basis. For this purpose in practice we use the following formulas (2):

the first one: reduction to the total capital investments;

the second one: reduction to the specific annual cost on present basis.

Our conclusion is the following:

There have been presented a large number of models for forest sector development. All of them are of great interest and usefulness for each country presented here, because each country by using other's country experience in model building will have the possibility to improve their own models. No doubt that variant calculations made for a certain region development on the basis of several models could be of great interest. We also think that some countries could use these models to forecast their own forest sector development. We are sure that the results comparison would be of great usefulness for all the countries. That is why we propose that IIASA will stimulate such a collaboration.

Якунин А.Г.  
Директор ВНИПИЭИ леспрома

О ПРИМЕНЕНИИ СИСТЕМНОГО АНАЛИЗА В РЕШЕНИИ  
ОТДЕЛЬНЫХ ПРОБЛЕМ РАЗВИТИЯ ЛЕСНОЙ И ДЕРЕ-  
ВООБРАБАТЫВАЮЩЕЙ ПРОМЫШЛЕННОСТИ СССР

Лесная и деревообрабатывающая промышленность занимает важное место в экономике страны. Ежегодно в СССР заготавливается примерно 400 млн. куб. м. древесины - это больше чем в какой-либо другой стране; производится 100 млн. куб. м. пиломатериалов - также больше, чем в других странах; 5,0 млн. куб. м. древесностружечных плит, около 500 млн. кв. м. древесноволокнистых плит и большое количество другой продукции.

Базисом, фундаментом лесной и деревообрабатывающей промышленности, как известно, является лесозаготовительная, добывающая отрасль производства.

В настоящее время лесозаготовительный потенциал отрасли составляет более тысячи крупных лесопромышленных предприятий, хорошо оснащенных самой современной техникой. Достигнув практически полной механизации на всех основных технологических операциях в лесозаготовительной отрасли, в настоящее время решается более сложная задача - внедряется машинный способ производства, при котором полностью исключается ручной труд на заготовке и транспортировке древесины, т.е. рабочий не вступает в непосредственный контакт с предметом труда - деревом, бревном.

Для осуществления этой задачи уже созданы и продолжают непрерывно совершенствоваться специальные системы машин.

Разработка и внедрение машинного способа производства, как показывает наша практика, является сложной научно-технической и социальной проблемой. Ее сложность начинается уже с самого начала,

с идеи системы, с необходимости создания комплекса машин разных по назначению, но взаимоувязанных по технологии, производительности и, желательно, по техническому обслуживанию. Система машин должны отвечать также требованиям лесозаготовительного производства и лесного хозяйства, т.е. она должна способствовать не только эффективной добыче леса, но и по возможности не нарушать лесную среду, учитывая необходимость последующего быстрого восстановления, улучшения охраны и защиты лесонасаждений. Добавим к этому, что лесорастительные и климатические условия у нас весьма разнообразны: от таежных районов Сибири до субтропиков Кавказа.

Новые машины - весьма сложные агрегаты и их эксплуатация требует высокой квалификации как рабочих, непосредственно занятых на этих машинах, так и инженерного персонала, управляющего всем циклом работы.

Отсюда вытекает необходимость повышения уровня подготовки этих категорий работников, а также разработки более совершенных принципов управления производством. В этой связи для нас также представляет интерес не только экономические, но и социальные последствия внедрения новой системы машин: как изменяется характер труда, престижность профессий, возраст работающих и т.д.

Несмотря на огромные лесные запасы, в нашей стране последовательно осуществляется курс на то, чтобы возрастающие потребности в древесине обеспечивать преимущественно за счет более полного использования биомассы дерева при минимальном увеличении объемов лесозаготовок.

Эта задача решается за счет создания безотходных производств, улучшения структуры производства, увеличения выпуска продукции,



использующей в качестве исходного продукта низкокачественную древесину, вторичное сырье - опилки, щепу, стружку и т.д.

Несмотря на то, что в семидесятих годах объем выпуска такой продукции (ДСП, ДВП технологической щепы и др.) непрерывно увеличивался, все еще значительная часть биомассы дерева не используется.

Представляется, что глубокий системный анализ современного состояния и перспективных направлений использования биомассы древесины, включая сучья, кору, пни, низкокачественную древесину лиственных пород, <sup>а также</sup> обмен информацией по этому вопросу между странами-Членами ИСА мог бы оказаться весьма полезным.

По расчетам экономистов потребление древесины в мире к 2000 году составит 4-4,5 млрд. куб.м.

В связи с возрастающим спросом на древесину в перспективе все острее будет стоять проблема наиболее рационального сочетания организационных форм лесоэксплуатации и выращивания леса. Здесь имеется ряд вопросов, которые нуждаются в хорошем системном анализе и экономическом обосновании: какой следует установить оборот рубки с тем, чтобы максимально сберечь леса от вырубki и вместе с тем увеличить объемы заготовки древесины; <sup>каковы</sup> оптимальные формы комплексных лесных предприятий; какие следует считать наилучшие формы организации плантационных лесных хозяйств; какие должны быть оптимальные организационные формы комплексных лесных предприятий и ряд других вопросов.

Системный анализ и прогноз оптимальных направлений сочетания лесоэксплуатации и выращивания леса является важной задачей прогнозирования развития отрасли и было бы желательным, чтобы

эти темы нашли отражение в планах работы ИСА.

Высокий технический уровень развития имеет в нашей стране и деревообрабатывающая промышленность.

Деревообрабатывающие предприятия, как правило, систематически модернизируются, переоснащаются новым оборудованием, внедряется новая технология и организация работ.

Преимущественное развитие в семидесятых годах получило производство древесностружечных и древесноволокнистых плит. Эти производства позволяют довести коэффициент использования биомассы дерева до 92-93%, что очень важно в решении проблемы рационального комплексного использования древесного сырья.

В стране построены и введены в действие многие заводы по производству ДСП. Так, например, мощность заводов по производству древесностружечных плит составляет от 110 до 250 тыс. куб. м в год.

Высокими темпами развивается мебельная промышленность. За восемь последних лет объемы производства мебели увеличились в 2,2 раза. Нарастание объемов производства мебели, повышение ее качества и обновление ассортимента достигаются за счет внедрения специализированного оборудования. В мебельной промышленности проводится большая работа по концентрации мебельного производства и его специализации.

Весьма эффективные меры в настоящее время принимаются также по развитию заводского деревянного домостроения.

Недавно принято решение значительно увеличить в предстоящем пятилетии производство панельных деревянных домов заводского изготовления.

Такие темпы роста производства домов, в прошлом не имевшие

прецедента, также будут обеспечиваться на основе концентрации и специализации производства и, конечно, за счет переоснащения предприятий высокопроизводительным современным оборудованием.

В целом деревообрабатывающая отрасль насчитывает в настоящее время несколько тысяч предприятий различной масштабности. Имеются сравнительно небольшие предприятия, перерабатывающие в сутки 0,5-1,0 тыс. куб. м. сырья.

Имеются гигантские лесопромышленные комплексы - например, Братский комплекс, перерабатывающий в сутки более 20 тыс. куб. м. сырья.

Для деревообрабатывающей отрасли одной из важных проблем, помимо внедрения новой техники, является эффективное решение задачи оптимальных форм концентрации, специализации и комбинирования производств.

Если к этому добавить, что формы концентрации, специализации, комбинирования предприятий, их размещение, размеры во многом зависят от природных и экономических условий соответствующих регионов, которые весьма разнообразны, сырьевых и трудовых ресурсов, транспортных потоков и многих других факторов, то эта задача является весьма сложной и требует для своего решения глубокого системного подхода.

Наша страна является страной, где экономика планируется, и поэтому для нас имеет большое значение разработка перспективных планов развития и размещения лесной и деревообрабатывающей промышленности.

Используя <sup>методы</sup> линейного программирования мы разработали оптимизационную модель, которая позволяет решить проблему - как обеспечить максимальный объем конечной продукции (пиломатериалов, плит, фа-

неры, мебели т.д.) при минимальных текущих затратах и максимальной экономии капиталовложений. Альтернативность ситуации состоит в том, что производство одной и той же продукции в разных районах может привести к экономии затрат на производство и транспортировку сырья и готовой продукции, но в то же время потребовать дополнительных капиталовложений на строительство производственных объектов, транспортных путей, создание инфраструктуры.

Модель предоставляет возможность определить альтернативы и выбрать оптимальное решение.

На семинаре было доложено о наличии большого количества моделей развития лесного сектора, разработанных в разных странах. Все они представляют интерес и пользу для каждой отдельной страны, так как каждая страна, используя опыт другой по созданию моделей, будет иметь возможность улучшить свои собственные разработки. Несомненный интерес могут представить также и варианты расчеты выполненные для одного какого-либо региона по нескольким моделям. Мы полагаем, что анализ и сравнение моделей будут полезными для всех стран-членов ИСА и поэтому предлагаем, чтобы ИСА способствовал такому сотрудничеству.

## INTEGRATED UTILIZATION OF TROPICAL FORESTS

Detlef Noack, Hamburg

### INTRODUCTION

About half of the forests of the world are located in the tropics. But at present the immense potential of tropical forests is in striking contrast to the modest contribution they now make to human welfare. In many tropical countries large areas of forests are hitherto unexploited or exploited to a very limited extent by selective extraction of very few commercial woods, well-known and well-introduced in international timber markets. But these forests contain substantial volumes of little-used and lesser-known wood species which normally correspond to more than 80% of their total volume. In order to assess the potential utilization of tropical moist forests it is therefore necessary to bring into fuller use also these lesser-used unknown species. This goal evidently necessitates some modifications of the current practices of exploitation and industrial conversion.

### HETEROGENITY OF TROPICAL FORESTS AND ITS INFLUENCE ON THE POTENTIAL OF UTILIZATION

Characteristically, tropical rain forests are a mixture of a large number of tree species with a wide spectrum of ages and diameters. The vast majority of the species occur very infrequently.

Because of their heterogeneous botanical composition natural tropical forests produce timber with widely varying properties. This can be rather inconvenient for the mass production in wood industry.

The timber volumes of tropical forests may range from 150 to about 400 cubic meters per hectare, but much of the timber has not been shown to be useful for products other than fuel. At present, however, fellings are mostly highly selective by extracting logs for export and for the production of primary wood products as lumber, veneer and plywood. The harvest of this selective felling often is only a few per cent of the total timber volume.

This selective felling of commercially preferred species has some striking disadvantages:

- the unused species are considered as weeds so that the remaining forest area is highly degraded or devaluated;
- potentially useful species are destroyed;
- the unused species interfere with the harvesting of valuable species and increase the cost of their recovery;
- timber harvesting, even on a highly selective basis, often opens up hitherto inaccessible areas for agricultural settlement which leads to further degradation or destruction of tropical forests by clearance burning and shifting cultivation.

As a result the total forest area in the tropics is decreasing at rather a fast rate which is estimated to be at least in the order of 12 million hectares per year. These conditions show clearly that it is necessary to change over from selective felling to a systematic larger scale logging. This change cannot only be considered from the viewpoint of wood technology but must also take into account the special ecological features of tropical forests. All further considerations about the utilization of tropical forests are therefore made on the principle pre-requisite that the utilization will conform to long-term decisions about the land use as well as with silvicultural needs and forest management regulations. Land use policies are necessary to provide the framework for developing exploitation methods and techniques.

We therefore have in the first run to concentrate our efforts on those large areas of natural tropical forests which will be converted into new kinds of land use which generally allow clear felling such as forest plantations with fast-growing species, land for agri-silviculture, agricultural land, water reservoirs, etc. These are the tropical forest areas of large extent which must be utilized more efficiently in future.

#### GENERAL TRENDS IN CONSUMPTION AND DEMAND OF WOOD AND WOOD PRODUCTS

The utilization of tropical forests must be further considered in close connection with local and world demand for wood and wood products. As we know from statistics and prospects of FAO we have to expect a steady increase in demand for timber and forest products, and also the consumption of paper and paper products will continue to grow rather fast.

A very important feature of wood demand is that tropical countries use large quantities--more than 80% of the total cut--as fuel, and in many parts of the developing world there is expected to be an increasing demand for fuelwood as a source of energy for cooking and heating.

These general developments in consumption and demand of wood and wood products are of great importance to the wood producing countries and will influence their industrial development. On the whole, it can be expected that the trend of a growing volume of processed wood entering international trade will expand further.

#### PRESENT SITUATION OF THE PRODUCTION OF WOOD AND FOREST PRODUCTS IN COUNTRIES WITH TROPICAL FORESTS

It is true that wood producing developing countries have been able, during the last decade, to expand local industrial processing to some extent. But, nevertheless, the value of exports of wood and wood products from tropical countries is only in the order of 15% of the world's total trade of these products, and much more striking is the fact that the proportion of wood exported as roundwood in its raw unprocessed state from these countries is still rather high (about 70% of the volume equivalent), with the result that many tropical countries have to import too many manufactured wood products.

All in all, rather few forest industries have been established up till now. The principle conversion in tropical countries is still sawmilling, and the current trend is to convert a larger portion of the logs into sawnwood and export the timber in sawnwood rather than in log form. Furthermore, there is some processing of plywood and veneers and very little of other panel products such as fibre board and particle board. The production of pulp and paper has only a limited amount so far, but it is of high local importance.

As a consequence of this situation a growing number of tropical countries are limiting exports of logs and have started investment programs in order to build up their own forest industries aimed at meeting expanding domestic requirements and at substituting log export more and more by exports of processed wood.

#### DEVELOPMENTS TO A MORE EFFICIENT, INTEGRATED UTILIZATION OF TROPICAL FORESTS

A complete, integrated utilization of currently under-exploited forests means that at least theoretically all the trees in the forest are used for producing forest products required at local and foreign markets. The ultimate solution to the problem of utilizing all the species as well as mill and forest residues may well be the integration of different mechanical and chemical processing methods. Such an integrated utilization will be the ideal goal which at least can be realized under especially favorable conditions. Well-known examples of such an integrated operation to commercially utilize the complete tropical forest resource are, for instance, two companies located in the Philippines. Both companies export logs and manufacture the primary wood products of lumber, veneer and plywood. To utilize their manufacturing residues and smaller diameter trees, one company manufactures hardboards and the other pulp and paper (newsprint, linerboard, corrugated paper). Both companies generate a large share of their energy requirements by burning bark and residues from manufacturing.



UTILIZATION OF LESSER-USED SPECIES BY MATCHING END-USE  
REQUIREMENTS WITH WOOD PROPERTIES

But for many tropical forests this complete utilization will still be an unattainable goal because of different factors which influence the structure of forest products industries within a country or region. Therefore, it will often be a first, but important step in the direction of a more efficient, integrated utilization to utilize a far greater proportion of the forest which means a much greater number of species of timber.

Current marketing of timber is typically species oriented and the ultimate use of the wood and the form in which it is used is often unknown to the primary processor.

One important step to reach a more intensive exploitation of tropical forests by utilizing a greater portion of the up-to-now lesser-used species will be a fundamental change in utilization policy. Instead of species oriented extraction of individual trees the timber selection in the forest and the processing of wood should be end-use orientated by grouping a number of lesser-used and well-known species having similar properties with respect to their specific end-uses.

An end-use property classification defines for each type of timber products the properties of significance and their levels such that timbers meeting these property requirements can be expected to give a satisfactory performance both in manufacture and use.

With regard to tropical woods, especially to lesser-used wood species, the knowledge of the relation between wood properties and end-use requirements is therefore of considerable importance to their utilization. It is an important task of research and development in the field of tropical woods to determine those use-related wood properties. This task needs close cooperation of all forest products laboratories in the world working in the field of tropical wood research. To enable this cooperation, the International Union of Forest Research Organizations (IUFRO) has established a special Project Group (P5.01) on "Properties and Utilization of Tropical Woods".

WHOLE TREE UTILIZATION OR BETTER USE OF THE AVAILABLE RAW MATERIALS

The current use of tropical woods is rather wasteful; firstly, in harvesting wood for lumber, appreciable quantities of useful wood are left behind in the forest. Further considerable losses occur in logging and in transportation. Finally, there are remarkable quantities of residues from processing because production methods are mostly rather rough and simple.

More intensive utilization by better use of the available raw material may often be the only solution to ensure economic production.

If the only conversion facility available to a tropical forest is a sawmill--as it is often the case--then the utilization potential of the forest will be rather limited. Therefore, a further general step for improving the utilization of tropical forests is a better utilization of the trees, which are cut in the forests, by:

- improving wood felling,
- reducing the residues of harvesting and processing,
- introducing different methods of horizontal and vertical integrated processing in wood industry especially in order to utilize more fully low value timber as well as forest and mill residues.
- improving the classifying of logs into raw material for different converting processes of the wood industry according to their wood quality and log form,
- using wood and residues of other processes as a source of energy, especially as fuel for domestic purposes and for processing.

In most tropical countries timber industries are still at preliminary stages. But in future, an increasing part of wood species of tropical countries will be processed on the spot. Combinations of various production methods of the wood industry must be established in order to make a complete utilization of tropical forests possible.

The wood industry is not prepared to use species with unknown processing performances. Therefore, studies are necessary on the relation between wood properties and the requirements wood has to meet by serving as raw material for different technologies and production methods.

An integrated approach to the utilization of tropical woods demands the establishment of wood industry complexes especially designed to utilize the available resource as efficient as possible. Those wood industry complexes therefore consist of different conversion processes which are adapted to the local conditions and which are integrated horizontally and vertically. Wood waste from conversion units, such as sawmills, veneer and plywood mills, may often be a very important raw material source both for wood-based panels (particle boards and fibre boards) and for wood pulp. But it must also be recognized that the mill waste often provides the fuel for power supplies and heating in wood processing plants.

The concept of an integrated utilization of tropical forests requires a variety of processing techniques which complete each other. The starting unit to utilize tropical forests normally is a sawmill, because lumber manufacture tends to be high in labor intensity, low in capital and process energy requirements, and produce a timber product which is of high utility value for housing and other purposes. Typically, an integrated conversion complex will in the first stage consist of production units for sawnwood, veneer and plywood. But a better utilization of the raw material can be reached, if processes are included that produce particle board, fibre board or pulp and paper products and, last but not least, fuel. But in addition, also the production of other products of primary wood industries, for instance sleepers, block-boards, cement-bonded wood-wool boards, may be of significance.

#### ADAPTATION OF PROCESSING TECHNIQUES

In order to realize a more efficient integrated utilization of tropical woods it is a fundamental prerequisite to adapt the different processing techniques and capacities to the particular conditions of each individual case. Most mills in tropical countries may require especially designed equipment or at least extensive modification of existing equipment. In this respect,

development of low cost machinery with smaller capacity and less sophisticated construction, which gives products of good quality but which may require substantial labor force, is greatly needed. This approach is also in accordance with the latest concept of FAO to promote the installation of small-scale wood-based panel plants and of small-scale pulp and paper mills.

It is evident, however, that an integrated utilization of tropical forests by a combination of a variety of different processing techniques can only be successful, if it can rely on skilled managerial and operational personnel.

#### FUEL AS A COMPONENT OF INTEGRATED UTILIZATION

It is important to point out that by far the most widespread single use for wood in most developing countries is for fuel, and a further increasing demand for fuelwood is to be expected. On the other hand, fuel provides an efficient use of wood which would otherwise be wasted, of trees left in the forest and later destroyed in the cause of land clearance as well as of waste produced in the course of processing.

This situation calls for a systematic strategy of collecting and processing suitable raw material for a well-ordered fuel production. It is obvious that this production of fuel should be an important component to a more efficient, integrated utilization of tropical forest.

#### IDEAL MODEL OF COMPLETE, INTEGRATED UTILIZATION OF TROPICAL FORESTS

If the preceding considerations are followed consequently, they will result in an integrated utilization of the complete resources of tropical forests in those cases where a total clearance of the natural forest area is in accordance with the general policy of forest utilization then depends greatly on fundamental decisions--made directly after felling--about what tree and which part of a tree respectively shall be determined to which conversion process.

The most valuable logs of decorative wood species will be used for veneer production whereas logs of good quality and shape with larger diameters should preferably be utilized in plywood

production, especially when the wood has a low to medium density or when its conversion to sawnwood meets with difficulties in sawing or drying. Other logs of good quality will then be allocated to lumber production, if the wood properties are in line with the requirements of end-uses. A large portion of hitherto unused tropical hardwoods as well as of forest and mill residues can be utilized as raw material for reconstituted boards or pulp products. And the remaining wood resources which cannot be used for producing forest products should be converted into fuelwood, charcoal or used as fuel for power-generation and heating in wood processing, respectively. Especially charcoal will be a valuable outlet of both very dense and silicious timber.

In future, the raw material supply of the established wood industry will increasingly be met by plantations. Therefore, reforestation should not only be carried out with fast-growing species having relatively short rotation periods, but from the viewpoint of wood technology larger parts of the man-made forests should also contain slow-growing species with valuable wood properties.

But in the beginning we have to solve many still existing problems connected with a complete, integrated utilization of the natural tropical forests. This requires strong efforts in research and development in order to meet the challenge of the next decade which surely will be to utilize the valuable natural resources as efficient as possible.

## O. Eckmüllner, Vienna: Forestry and Forest Industry in Austria.

AUSTRIA is often said to be a "Kammer-Staat", i.e. a State, where the influence of the "Chambers" is a very important one. In fact, the Chambers of Agriculture & Forestry, the Chambers of Trade & Commerce, the Chambers of Workers & Employees and last, but by no means least, the Labour Unions play an important role. These four institutions cooperate in the so-called "Paritätische Kommission", in which they are equally represented; their task is an advisory one to the Government. This works very well and the result is social peace; strikes are almost unknown in Austria.

Forestry is represented by the Chambers of Agriculture & Forestry, Forest Industry by the Chambers of Trade & Commerce. These two big Chambers have, as their own advisory institution, the "Federal Timber Council" (Bundes-Holzwirtschaftsrat), in which forestry and industry are equally represented. This Federal Timber Council is the institution, where all the problems of common interest to forestry and forest industry are being discussed and where normally a consensus is reached. The Council informs then the two Chambers and asks them to take the necessary steps with the Government. Of course, all this concerns economic problems only. Problems of a wide range - concerning environmental questions or so - are being dealt with in Parliament.

AUSTRIA has 7,5 million inhabitants, 250.000 of them being forest owners, of which 600 only big ones with more than 500ha. 80% of the Austrian forests are privately owned. One could expect that the political weight and influence of 250.000 forest owners and their families might be a considerable one, but in fact more than 90% of them are farmers and these farmers are first of all agriculturists and have always had extremely difficult problems with the ever increasing overproduction of practically all - milk, butter, cheese, cereals, cattle, pigs, hens and eggs, fruit and wine etc. In relation to agriculture forestry has almost no problems and there are only few people fighting for forestry! Politically forestry is more or less absent in Austria.

AUSTRIA is very mountainous, two thirds of her forests are situated in the Alps. The forest area is 3,7 mio ha, that is 44% of the total area and 0,5 ha per capita. Almost 800.000 ha = 20% are protection forests near the timber line or on very steep slopes. The area of "commercial forests" is, therefore, only 2,8 mio ha.

The main species are spruce, pine, larch and fir, together 85%, and beech (mainly in the famous "Vienna Woods") and oak, ash, elm and maple, together 15%. The growing stock is in total 770 mio cbm overbark, that is 255 cbm/ha. The annual growth is 19 mio cbm overbark, i.e. 6,3 cbm/ha. Both, growing stock and annual increment are steadily increasing, because the annual cut, the wood harvested, is only 10 to 12 mio cbm underbark, that's about 20% less than the annual growth. Thus, the Austrian forests become richer in volume of wood and in growth, but also bigger in area, because every year around 5000 ha of marginal agricultural land is being turned to forestry and afforested - without any change in property.

Sales on the stump, i.e. of standing timber is almost unknown in Austria; a forest owner, who isn't able to harvest his wood himself, would be regarded "impotent".

SAWMILLING: Austria has about 3000 sawmills, of which only few are big ones with 100.000 to 200.000 cbm roundwood input per year. About 300 sawmills, however, close down every year, mainly small ones, and production is concentrating with bigger mills. The main equipment are frame-saws; the output of sawnwood is 0,67 cbm per 1 cbm of sawlogs. The residues (33%) are at a rate of 85% industrially utilized, mainly in the pulp, particle board and fibre board industry. Total input of sawlogs is 8 to 10 mio cbm, of which 5 to 10% are being imported. There is a remarkable

trend to the processing of small-sized logs, down to 10 or 12 cm Ø.

The sawnwood - 5,5 to 6,0 mio cbm - is used in Austria with about one third; two thirds are being exported, mainly to Italy, Germany, Switzerland, but also to the Mediterranean countries and to the Near East. On the World Market for sawn softwood this small country of Austria is the fifth biggest exporter, after Canada, USSR, Sweden and Finland.

PULP & PAPER: Austria has a fairly developed pulp and paper industry with a high rate of exports (about 50%). Almost all mechanical and chemical pulp produced in Austria is further processed to paper and cardboard, so that almost no exports of these semi-products are made, but big exports of finished goods. However, the raw material, the pulpwood, has to a high degree (30-40%) to be imported from CSSR, Hungary, Yugoslavia, Roumania, Poland and the USSR., but it is mainly beech and pine, of which the Austrian pulpwood production is insufficient. A problem of growing interest is the distinction between sawlogs and pulpwood; in former times roundwood up to 20 cm Ø was pulpwood, bigger roundwood was sawlogs. But now much small-sized roundwood is bought by sawmills to a higher price than pulpwood. Of course, forestry is very happy about this development. Nowadays even fuelwood is becoming a competitor to pulpwood, as it is going to replace oil and has in some places already got a higher price than pulpwood.

#### WOOD BASED PANELS:

Particle Board production began in Austria in 1954 and is still increasing. Home consumption is now about half a million cbm annually, i.e. 75 cbm/1000 capita. About the same amount - half a million cbm - is being exported. The composition of the raw material has greatly changed; it is now: 7% conifers, 27% hardwood, 64% residues.

Within fibreboard only hardboard shows a satisfying development. Home consumption is 45.000 to 50.000 t, corresponding to 6 - 6,5 t/1000 capita. The share of exports is 30 to 40% of total production .

Insulation board shows a steady decrease in production as well as in consumption. Two thirds of the production are being exported.

With regard to plywood the development is still worse. Home consumption consists of about 10.000 cbm, home production however is only about 3000 cbm.

Home consumption of wood based panels in total has reached about 20% of the home consumption of sawnwood. A further increase up to 30% is expected for the years around 2000.

**SYSTEMS ANALYSIS IN FORESTRY AND  
THE FOREST INDUSTRY: AN OVERVIEW**

**Paavo Uronen**



## PREFACE

This paper is a survey discussing the use of systems analytical methods in planning and decision making in the forestry and in the forest industry. The number of papers and studies discussing different applications of systems analysis in this sector is wide and rapidly increasing. However the real uses of these methods in practice is hard to predict. So there is clearly a need for detailed state-of-the-art studies at two levels: in research and in practical uses of these methods in the forest.

The paper was presented at the IIASA Forest Industry Workshop, January 8-11, 1980.

SYSTEMS ANALYSIS IN FORESTRY AND  
THE FOREST INDUSTRY: AN OVERVIEW

Paavo Uronen

INTRODUCTION

Systems analysis, i.e., modeling, simulation, optimization and planning techniques, etc., has been widely used in separate areas of the forestry sector since the end of the 1950's. If we consider the whole sector, (i.e., from silviculture and timber management to the operation of the mills and marketing of the final products, there are totally different application tasks and therefore the methods and solutions used vary greatly. In the forestry area, for example, the LP-applications are typical but in the mill operation real-time control and optimization systems have wider use.

The development in the whole area of applications has been very rapid. Chappelle (1977), for example, gives statistics concerning the increase of LP-applications in forestry in the US: there were two applications in 1955 and 105 in 1970. The application here means that it is a study of application not necessarily used by foresters or managers. Today, there are hundreds of publications on the application of different methods or systems analysis in the forestry and forest industry. So it is impossible in this kind of overview to list and evaluate all or most of them. This survey is, therefore, designed to take a look at the whole area, i.e., all methods in all applications. The aspects discussed will remain very general and no detailed comments on most individual papers can be made. Some studies mentioned here are merely taken based on the abstract only if the application or method applied is new or of special interest just to show the whole range of possible applications and methods.

The general feature here is that most applications still are on paper, i.e., the researchers are speaking and writing to each other. The number of real applications is still quite low. There are several reasons for this, including:

- difficulties in getting all the data needed for the application;
- local needs for modification and adoption;
- complicated programming and hardware requirements;
- need for special staff;
- misconceptions and reluctance against new ideas;
- lack of practical results, i.e., cost-benefit analysis of these methods; and
- difficulties in handling multiple-usage problems and stochastic situations.

Lately there have been several computer program packages constructed for different (mostly timber management) applications, and these packages may promote the practical use of the methods. On the other hand, a "solution package" may have the tendency to modify the problem to fit better with the program package and thus the solution may lose some important local features necessary for decision-makers. The rapid development of computer technology will also ease the usage of systems analysis. One example for stock inventory systems is a micro-processor packed in a backpack for data gathering on the site.

What might be useful in this connection is a study concerning real applications, results, experiences and problems in using systems analysis in forestry and the forest industry. The results of this study could then be used for directing R&D in the area to real problems.

In the following sections, the whole wide area will be divided into: timber management, forest sector economy, planning of industry, land usage, production and operation, and other applications. Each field of application will be briefly discussed with a related Table that indicates the typical tasks and typical methods used. The reference numbers utilized in these Tables refer to the publications, etc., listed in the Reference Section. (Refer to the Notes Section for proper referencing of these numbers.)

#### TIMBER MANAGEMENT APPLICATIONS

The basic and most important problem to be solved in timber management is the temporal and spatial scheduling of silvicultural and harvesting activities during a planning period (50-100 years) in order to maximize (or minimize) the objective

function and fulfill all constraints. The objective function used may be: present net worth of the stock, stock volume, return rate of investment, allowable cut, sustained long-term yield, timber production costs, etc. The constraints include, a.o., allowable annual cut, labor force available, reforestation area, capital available, etc. In order to be able to solve this kind of long-term planning problem a simulation model for timber yield and growth must also be available.

Linear programming is a widely studied method for the solution of this problem. Table 1 shows an overview of selected application studies in the timber management area and we can easily see how dominant the linear programming method is. Many reference numbers will occur twice (or more) because modeling is essential in all methods. Many published studies could also be put in some other area too in this quite arbitral classification. Some modifications of LP, for example goal programming and also non-linear and dynamic programming, have been studied, but so far the practical use of these methods have been very limited. The practical use of LP has been limited to big corporations with enough special staff and forest land, or to public forest owners and organizations, for example in the U.S. and Australia (Australian Forestry Council 1978; Navon 1971).

There are certain limitations in the use of LP in the above problem. First of all, the model, the objective function and the constraints should be linear; how well this is justified in each particular case is dependent on many factors, a.o. silviculture, species, validity of growth model, terrain, etc. Also, in this kind of long-range planning the question of uncertainty and the stochastic nature of the process are rather important. Additionally, more will be discussed about the multiobjective nature of forest management, thus the optimal production of timber will not be the only objective (e.g., recreation, use of forests, wilderness, wildlife, natural watershed, forage, conservation, etc. can be taken as additional constraints or goal programming can be used). This is closely connected with the area of land usage and it will be discussed later.

A major type of problem closely connected with timber production and harvesting activities is the planning of logging and transportation of timber. Here also, as can be seen from Table 1, linear programming is mostly studied and applied. Some very interesting studies concern the use of optimal control theory in timber management (Andersson 1976; McDonough and Park 1975; Mitchell 1976; Newnham 1973). The LP-program packages developed will be very helpful in calculating the outcome and effects of different policies, activities and choices; it does not, however, solve the principal problem: what should be the real objectives, constraints and policies? This question will be especially important in the case of multiuse or product-mix of the forest lands.

Table 1. Timber management

Task Objective	Method	Modeling & simulation		Net-work anal.	Goal prog.	Non-linear prog.	Dynam. prog.	Modif. of LP	Opt. cont. theory	DLP	Syst. dynam.	Time series anal.	Other
		LP											
Stock inventory, growth, yield			3,6,7,14, 27,30,45										3,14
Present net worth maximation			4,58,86	6,40			58		4				
Sustained yield			36										
Allowable cut			18,37	37		37							
Harvesting planning			6,12,13, 25,42,46, 50,51,56, 71,72,73, 79,86	6,12, 13,25, 42,50, 51,56, 79,86	25,73		71		46				72
Harvesting & transportation			9,19,21, 31,57,69, 83	31,53, 83				21					21
Silvicultural and/or transportation planning			30,55	85			55						

## FOREST SECTOR ECONOMY APPLICATIONS

Table 2 shows a collection of typical applications in forest sector economy applications. Most of these include modeling and simulation only: this is understandable because, for example, the optimization of a forest sector economy (regional or national) is a very complicated multiobjective task. Some studies are now underway in this direction. The modeling methods used are typical econometric models; input-output modeling (Rafsnider 1975), cost-benefit analysis, and systems dynamics for regional and national sectors, regression models or time series forecasts for global trends and market studies. For industry development and reforestation projects also some LP applications exist.

The main problem here is the long-term forecast for this sector on global, national and also regional levels and how to use these forecasts. They can not be used in individual corporations or mills; possibly their best use can be found in discussions between different interest groups (industry, forest owners, government, labor unions, environmentalists) when the future development or choices concerning the forests usage are explored. Typical examples of these kind of studies on a national level are Jegr (1978), Kallio, et al. (1980), Randers and Lönnstedt (1979), and Randers, et al. (1978).

## PLANNING OF INDUSTRY

There are several modeling and simulation studies (regional and national) concerning the planning and development of the forest industry (pulp and paper or sawmills and other mechanical forest industry). These studies are mainly based on forecasts and trend models for demand and supply possibilities and the parameters in these models are estimated based on historical data. These trends are then used in simulation studies for the different locations of mills and the different production mixes and sizes of mills.

The optimal mill location problem has been solved by the LP-technique in some simple cases taking, for example, only the transportation costs into account (Abel 1973). LP technique and investment cycle theory have also been used in some investment policy studies. The possibilities of dynamic programming and systems dynamics have also been studied in this area (Randers, et al. 1978; Ruprich 1974). Table 3 summarizes the studies in these topics.

What was stated in the previous section is also very valid here; the models and solutions are so aggregated on the national and regional level that they are not very useful for real projects; they can serve as implications for future trends and possible investment policies. However, these models assume a constant technology and adhere to the existing pattern and trend in world markets and consumption. This can not be true in the long-term; so what is really needed here is the study of consistent world trade study and the study of technological change in this area.

Table 2. Forest sector economy

Task Objective	Method	Modeling & simulation	LP	Network anal.	Goal prog.	Non-linear prog.	Dynam. prog.	Modif. of LP	Opt. cont. theory	DLP	Syst. dynam.	Time series anal.	Other
Global aspects		107											
National sector		3,18,49, 52,72,91, 94,95,106								52	49,52, 94,95		
Regional sector		5,36,47, 96										85	92
Supply & demand		18,85,92, 96,106,107, 110,120,											
Forest industry forecasts		3,61,97						61					
Reforestation & plantation		15											





For one corporation and mill, more detailed and technical models have been built, but these naturally include so much proprietary data and information that very little has been published (Zackrisson 1977).

#### LAND USAGE

As previously mentioned, the multiobjective use of forest land is now becoming a target of many discussions between policy-makers, industry, and forest owners. There will be competition for land between agriculture, timber production, recreation, general conservation, wildlife, forage, etc., on the one hand, and for the timber (i.e., biomass) produced in forests, between the traditional industry (pulp, paper, mechanical), energy production, and the chemical industry, on the other. In this connection, when national and regional multiple-use of forest lands is planned (this concerns especially Public Forests, and also a big corporation), the use of systems analysis can be helpful.

Several studies in this area have already been made as can be seen from Table 4. The most studied method in solving the above described optimal product-mix problem is the LP-technique. The difficulty here is how to formulate the objective function, and how to evaluate the value of non-commodity products; for example, recreation usage or wildlife of forests. One method is to take the production of timber as the objective and the demand on other uses as additional constraints. (This has been done, for example in Timber-RAM; see Navon 1971.) Goal programming is also quite a well studied method in this application. It is believed that the development in multicriteria optimization theory will soon give more powerful methods in the solution of these kinds of problems; however, the main difficulty still remains: how to evaluate and put value on different competitive products?

The problem will become still larger as it is not just the forest owner alone who will be involved here: many different interest groups (government, labor unions, environmentalists, recreation users, etc.) will be interested in this question and so the long-term policy concerning forests will be a target of great interest. Flick (1975) has suggested the use of input-output analysis to solve the value problem in multiple usage of forest land. For this kind of situation the possible use of gaming and value analyses have also been studied (Countryman 1974; Henne 1978).

#### PRODUCTION AND OPERATION OF MILLS

This area of systems analytical applications in the forest industry is well-developed and it includes the wide range from process control into the planning and investment models for a corporation. Concerning the process control studies and applications, there are so many that only some of the recent surveys

Table 4. Land usage

Task Objective	Method		Net-work anal.	Goal prog.	Non-linear prog.	Dynam. prog.	Modif. of LP	Opt. theory	DLP	Syst. dynam.	Time series anal.	Other
	Modeling & simulation	LP										
Planning of land usage	9, 10, 12,	12, 51,	10, 25	51	119	56						22, 45
	22, 25,	67										
	45, 51, 56											
	67, 119											
Forestry budgeting	22, 57	57	57									22
Non-timber products	76, 87											
Multiple-usage	21, 34,	34, 65	102									34, 41,
	35, 41, 46,											
	48, 65, 99,											
	102, 104											

have been listed in Table 5 (Gee 1977; Keyes 1975; Uronen and Williams 1978). These applications mostly use quite simple mathematical models of the technological process to be controlled and optimal control theory in a straightforward manner. The use of a digital computer and also special measuring instruments are essential for all of these applications.

In recent years, increased interest in more management type applications in this industry has arisen; the allocation of resources, production planning, coordinated operation of different units and subprocesses, management information systems, etc., are typical examples (Ahlsholm and Pettersson 1970; Edlund and Rigerl 1978; Leiviskä and Uronen 1979a, 1979b; Oliviera, et al. 1977; Uronen and Williams 1978). This, together with rapid development in computer hardware and software, will mean a more increased integration of these tasks and operations into a hierarchical management, information, planning, operation and control system of the mill. This will definitely be the most important topic for further research and development in this area.

#### OTHER APPLICATIONS

There are a lot of interesting applications of systems analysis in special purposes related to the forestry/forest industry as listed in Table 6. Road planning and transportation planning applications with network analysis or LP-solutions are closely related to timber management and/or industry location problems, as earlier discussed. Fire detection and control systems and tree improvement application of the LP-technique are quite well studied and special cases have been documented.

It is obvious that more and more computerized resource information, data collection and analyzing systems, databanks, and display and mapping systems are needed (e.g., in connection with the satellite surveying of forest resources, etc.).

#### PROGRAM PACKAGES

Table 7 gives a list of some well-known computer program packages developed for certain application in the forestry/forest industry area. Most of them are for timber management applications, and the LP-technique is the most common solution method used. In using these programs it is necessary that all relevant data (e.g., yield, growth, prices, labor costs, etc.) is made available. The usefulness of these programs is naturally connected with the limitations and problems discussed earlier, as in connection with timber management applications. The main use is in the rapid calculation of different choices, but the most important part of the problem--the section of objective and the setting of values and constraints--must be solved by the decision-maker himself. It is to be expected that more and more of these kinds of program packages will be developed and used.

Table 5. Production and operation

Method Task Objective	Model- ing & simula- tion	LP	Net- work anal.	Goal prog.	Non- linear prog.	Dynam. prog.	Modif. of LP	Opt. cont. theory	DLP	Syst. dynam.	Time series anal.	Other
Resource allocation	13,93, 100					100						
Process control	7,39, 54,113							39,54 113				113
Production planning	4,7,30, 42,63,64, 89,113, 120		30					4,42, 63,64, 89				63,64, 89
MIS	30,63 113		30									63

Table 6. Other applications

Task Objective	Method	Modeling & simulation	LP	Net-work anal.	Goal prog.	Non-linear prog.	Dynam. prog.	Modif. of LP	Opt. cont. theory	DLP	Syst. dynam.	Time series anal.	Other
Tree improvement		14,40	14										
Road planning		88,114,118		88,114									
Transportation planning		13,88,90	90	88									
Fire control		86,108											
Databanks & information systems		5,20,23,33,59,66,79,90,105	90										5,20

Table 7. Program packages.

Name of package	Refer- ence	Application area
TRES	68	Timer resource growth projection
FOREST	15	Simulation of timber growth
STANDSIM	8	Simulation of timber growth and yield
FORSIM	8	Simulation of timber growth
RADHOP	8	LP program for rationalizing yield flows through time to meet market requirements
MASH	8, 86	Maximizing the present net worth
ADVENT	57	Budgeting in forestry management
PUBLIC	12	Land management planning
Timber RAM	75	Forest management planning
TEVAP 2	74	Forest management planning
ECHO	109	Forest management planning
FOCUS	108	Forest fire control planning
LOGPLAN	81	Logging plan model
SVEN	9	Land usage planning
RAA	67	Resource allocation
INFORM	118	Informations system for management
TRIS	118	Total resource information system
WRIS	118	Wildland resource information system
AUTOMAP	118	Automatic mapper
CISC	118	Continuous inventory of stand conditions
PROGNOSIS	118	Model for stand development
TIMADS	118	Timber management systems
TRAS	118	Timber resource analysis system
WIPS	26	Woodlands information and planning
ECOSIM	118	Ecosystem simulation
RCS	118	Resource system simulation
RDS	118	Road design
OPTLOC	118	Optimal road location
RAM	118	Resource allocation
FRES	118	Forest range environment studies
MULTIPLY	118	Investment simulation
TAG	118	Transportation analysis

Table 7. (continued)

---

Name of package	Refer- ence	Application area
WRAP	45	Planning of wildland resources
ECHO	115	Harvesting optimization
GEL0	59	Mapping of forested areas

---

## SUMMARY

The number of publications discussing the use of systems analysis in the forestry/forest industry area is large and this survey will not cover all of these. However it can not, based on published reports, be concluded to which extent these methods are really used in everyday decision-making by management. Two dominant application areas can be identified: timber management and process control. Two other growing areas can also be seen: land usage and management information systems in mills. Based on this overview, several questions can be asked:

- There is a certain theoretical and methodological readiness in using these methods. Why are they not used more widely in forestry or in the forest industry?
- What are the bottlenecks in the use of these methods and programs?
- Should cost-benefit analysis be applied to the use of systems analysis?
- What are the main problems to which R&D should be concentrated?
- How could the existing models (e.g., in yield and growth of biomass) be improved?
- Do local circumstances change too much from place to place to enable the development of general models or program packages?

In addition to this, it is evident that technological change, the competition of land and raw materials, changing patterns in world trade and production, etc., will turn the planning of a forest sector into a very dynamic and complicated task. The decision must be made based on models, forecasts and data available: here effective use of systems analysis can be of great help. But even at its best, it will be only a set of tools; the final decision will always lie with the people, the management of the industry, and other decision-makers.



NOTES

The Reference Numbers contained in this section relate to Tables 1-6. They correspond to the publications, etc., listed in the References.

1. D.B. Abel (1973)
2. D.M. Adams, et al. (1975)
3. F.G. Adams, et al. (1973)
4. O. Ahlsholm, et al. (1970)
5. A.H. Aldred (1971)
6. F.J. Andersson (1976)
7. Anon (1979)
8. Australian Forestry Council (1978)
9. B.B. Bare, et al. (1975)
10. E.F. Bell (1975)
11. G. Bengtsson (1977)
12. D.R. Betters (1978)
13. S. Bucht (1972)
14. J.P. van Buijtenen, et al. (1972)
15. J. Buongiorno, et al. (1978)
16. D.E. Chappelle (1977)
17. D.E. Chappelle, et al. (1976)
18. M. Clawson (1979)
19. J.S. Clifford, et al. (1978)
20. D.J. Clough, et al. (1977)
21. F.J. Convery (1977)
22. D.W. Countryman (1974)
23. D. Den Uyl (1975)
24. B. Dolezal (1978)
25. P.E. Dress (1975)
26. K.M. Du, et al. (1975)
27. D.P. Dykstra (1975)

28. D.P. Dykstra, et al. (1976)
29. D.P. Dykstra, et al. (1977)
30. S.G. Edlund, et al. (1978)
31. A.R. Ek, et al. (1974)
32. N.R. Eldred (1976)
33. G.H. Elsner (1975)
34. W.A. Flick (1975)
35. W.A. Flick (1977)
36. K.S. Fowler (1978)
37. C.L. Gamble (1977)
38. R. Gauthier, et al. (1975)
39. J.W. Gee, et al. (1977)
40. D. Gerold, et al. (1977)
41. D.F. Gibson (1975)
42. L.A. Golemanov (1972)
43. M.L. Gustafson, et al. (1975)
44. A. Hagg (1973)
45. L.N. Hammer (1975)
46. A. Henne (1978)
47. D.L. Holley, Jr. (1977)
48. W.F. Hyde (1979)
49. M.M. Jegr, et al. (1978)
50. H.A. Jobstl (1973)
51. K.N. Johnson, et al. (1977)
52. N. Johnson, et al. (1975)
53. M. Kallio, et al. (1980)
54. J.T. Keane (1975)
55. M.A. Keyes (1975)
56. P. Kilkki, et al. (1975)
57. M. Kirby (1975)
58. M. Kirby (1978)
59. I. Kolenka (1978)
60. A.O. Lampi, et al. (1975)
61. F.R. Larson (1975)
62. W. Lebelt, et al. (1972)
63. M.R. Lembersky (1975)
64. K. Leiviskä, et al. (1979a)
65. K. Leiviskä, et al. (1979b)
66. W.A. Leuschner, et al. (1975)
67. H.G. Lund, et al. (1975)
68. L.J. Lundeen (1975)
69. A.L. Lundgren, et al. (1978)
70. J.M. McDonough, et al. (1975)
71. T.R. Mitchell (1976)
72. J. Muench, Jr. (1977)
73. R.A. Muller (1978)
74. P.A. Murphy (1976)
75. C.A. Myers (1974)
76. D.I. Navon (1971)
77. D.I. Navon (1975)
78. D.I. Navon (1976)
79. R.E. Neiman (1976)
80. D.H. Nelson (1975)
81. V.G. Nesterov, et al. (1974)
82. R.M. Newnham (1973)
83. R.M. Newnham (1975)

84. C.J. Norstrøm (1975)
85. W.F. Odendahl (1975)
86. R.A. Oliveira, et al. (1977)
87. W.G. O'Regan, et al. (1975)
88. H. Pabst (1978)
89. M. Palo (1971)
90. E. Pettersson, et al. (1978)
91. W.W. Phillips, et al. (1978)
92. D.H.R. Price (1977)
93. G.T. Rafsnider (1975)
94. S. Rajagopal (1978)
95. J. Randers, et al. (1979)
96. J. Randers, et al. (1978)
97. V.L. Robinson (1974)
98. M. Rogers (1979)
99. N.K. Rogers (1972)
100. C. Row (1977)
101. J. Ruprich (1974)
102. K.P. Rustagi (1976)
103. K.P. Rustagi (1978)
104. A.T. Schuler (1975)
105. A. Schuler, et al. (1975)
106. G. Schwarzbart, et al. (1975)
107. R.N. Stone, H.E. Dickerhoff (1977)
108. R.N. Stone, J.F. Saeman (1977)
109. T.G. Storey (1972)
110. P.L. Tedder, et al. (1978)
111. A.I. Tencer (1977)
112. M.J. Thevenon, et al. (1974)
123. H. Ulrich (1974)
114. P. Uronen, et al. (1978)
115. J. Virtanen (1972)
116. J.K. Walker (1975)
117. A. Weintraub, et al. (1976)
118. I.C.A. Weir (1972)
119. R.N. Weisz, et al. (1975)
120. D.H. Williams, et al. (1975)
121. U. Zackrisson, et al. (1977)

REFERENCES

- Abel, D.B. 1973. Linear programming and its application to the locational planning of wood-processing industries. New Zealand Journal of Forestry Science, Vol. 3, No.2.
- Adams, D.M., and A.R. Ek. 1975. Derivation of optimal management guides for individual stands. Systems Analysis and Forest Resource Management. Proceedings of a Workshop, Athens: Society of American Foresters, University of Georgia, August 11-13.
- Adams, F.G., and J. Blackwell. 1973. An econometric model of the united states forest products industry. Forest Science, Vol. 19, No. 2.
- Ahlsholm, O., and B. Pettersson. 1970. Integration of pulp-mill control with the production planning of a paper mill. Paper making systems and their control. Transactions of the Symposium, Oxford 1969. London: The British Paper and the Board Maker's Association Inc., pp. 209-231.
- Aldred, A.H. 1971. A Planning Model for Forest Inventories Based on Combined Photo and Ground Sampling Methods. Ph.D. thesis, University of California, Berkeley, California.
- Andersson, F.J. 1976. Control theory and the optimum timber rotation. Forest Science, Vol. 22, No.3.
- Anon. 1979. PIRA Seminar 539, Mathematical Modeling in or Applicable to the Paper and Board Industry, PIRA.

- Australian Forestry Council. 1978. Research Working Group No. 2, Techniques of Australian Forestry Planning. Proceedings of Meeting of Steering Systems Project Group, IUFRO, Bucharest, June 18-24.
- Bare, B.B., and G.F. Schrender. 1975. Environmental impact assessment modeling and land-use planning. Systems Analysis and Forest Resource Management. Proceedings of a Workshop, Athens: Society of American Foresters, University of Georgia.
- Bell. E.F. 1975. Problems with goal programming on a national forest planning unit. Systems Analysis and Forest Resource Management. Proceedings of a Workshop, Athens: Society of American Foresters, University of Georgia, August 11-13.
- Bengtsson, G. 1977. Hugin: A Swedish Research Project Development Methods for Long-term Forecasting of Timber Yields. Paper presented at the IUFRO Conference, Blacksburg, Virginia.
- Bettors, D.R. 1978. Analytic aids in land management planning. Proceedings of Steering Systems Project Group, IUFRO, Bucharest, June 18-24.
- Bucht, S. 1972. A Routine for One-Month Planning of Logging Operations. A model for the scheduling of operations and allocation of resources to individual logging units. Meddelande, Forskningsstiftelsen Skogsarbeten, No. 8, Stockholm, (in Swedish).
- van Buijtenen, J.P., and W.W. Saitta. 1972. Linear programming applied to the economic analysis of forest tree improvement. Journal of Forestry, Vol. 70, No.3.
- Buongiorno, J., and D.E. Teequarden. 1978. Operations research techniques in the management of large-scale reforestation programs. Proceedings of Steering Systems Project Group, IUFRO, Bucharest, June 18-24.
- Chappelle, D.E. 1977. Linear programming for forestry planning. In Forestry and Long-Range Planning, edited by F.J. Convery and C.W. Ralston, Durham, North Carolina: School of Forestry and Environmental Studies, Duke University.
- Chappelle, D.E., M. Mang, and R.C. Miley. 1976. Evaluation of timber-RAM as a forest management planning model. Journal of Forestry, 288-293.
- Clawson, M. 1979. Forests in the long sweep of american history. Science, Vol. 204.
- Clifford, J.S., et al. 1978. LP modeling in the paper industry as an aid to recycling decisions. Conservation Recycling, Vol. 2, No. 2.

- Clough, D.J., and L.W. Morley, eds. 1977. Earth observation systems for resource management and environmental control. NATO Conference Series, Series II: System Science Plenum Press, New York.
- Convery, F.J. 1977. Benefit-cost analysis and forest planning. In *Forestry and Long-Range Planning*, edited by F.J. Convery and C.W. Ralston, Durham, North Carolina: School of Forestry and Environmental Studies, Duke University.
- Countryman, D.W. 1974. Gaming-simulation; a technique in natural resource management in use of computers in forestry. *Proceedings of the 23rd Annual Forestry Symposium*, Baton Rouge, Louisiana: Louisiana State University.
- Den Uyl, D. 1975. Techniques of managing data for the industrial forestry firm. *Systems Analysis and Forest Resource Management, Proceedings of a Workshop*, Athens: Society of American Foresters, University of Georgia, August 11-13.
- Dolezal, B. 1978. A method of forest management for the planned introduction of intensive husbandry in virgin forest stands. *Proceedings of Steering Systems Project Group, IUFRO*, Bucharest, June 18-24.
- Dress, P.E. 1975. Forest land use planning: an applications environment for goal programming. *Systems Analysis and Forest Resource Management. Proceedings of a Workshop*, Athens: Society of American Foresters, University of Georgia, August 11-13.
- Du, K.M., and L.O. House. 1975. Integrated woodlands information and planning system. *Systems Analysis and Forest Resource Management, Proceedings of a Workshop*, Athens: Society of American Foresters, University of Georgia, August 11-13.
- Dykstra, D.P. 1975. Computer simulation analysis of timber harvest landings. *Systems Analysis and Forest Resource Management. Proceedings of a Workshop*, Athens: Society of American Foresters, University of Georgia, August 11-13.
- Dykstra, D.P., and H.A. Froehlich. 1976. Costs of stream protection during timber harvest. *Journal of Forestry*, Vol. 74, No. 10.
- Dykstra, D.P., and J.L. Riggs. 1977. An application of facilities location theory to the design of forest harvesting areas. *AIIE Transactions*, Vol. 9, No. 3.
- Edlund, S.G., and K.H. Rigerl. 1978. A computer-based production control systems for the coordination of operations in a pulp and paper mill. *IFAC Seventh Triennial World Congress. Proceedings*, Helsinki.
- Ek, A.R., and R.A. Monserud. 1974. *Forest: A Computer Model for Simulating the Growth and Reproduction of Mixed Species Forest Stands*. Madison, Wis: Res. Rep. Sch. Nat. Resour., University of Wisconsin.

- Eldred, N.R. 1976. Techniques of technological forecasting. Tappi-CPPA Full Graphic Arts Conference Papers, October 27-29.
- Elsner, G.H. 1975. Computer management of recreation data; terrain and usage studies for land-use planning. Systems Analysis and Forest Resource Management. Proceedings of a Workshop. Athens: Society of American Foresters, University of Georgia, August 11-13.
- Flick, W.A. 1975. A solution to the value problem of multiple-use planning. Systems Analysis and Forest Resource Management. Proceedings of a Workshop. Athens: Society of American Foresters, University of Georgia, August 11-13.
- Flick, W.A. 1977. Input-output analysis for forest planning. In *Forestry and Long-Range Planning*, edited by F.J. Convery and C.W. Ralston, Durham, North Carolina: School of Forestry and Environmental Studies, Duke University.
- Fowler, K.S. 1978. Toward a more integrated regional timber model. *Forest Science*, Vol. 24, No. 4.
- Gamble, C.L. 1977. An econometric model of the pulp and paper industry. Proceedings 7th Annual Pittsburgh Conference, Modeling and Simulation, Vol. 7, Part 2, 739-743.
- Gauthier, R., and M. Goulet. 1975. Examples of planning the conversion of wood by linear programming. Note Technique, Department d'Exploitation et Utilisation des Bois, Université Laval, No. 8.
- Gee, J.W., and R.E. Chamberlain. 1977. Digital computer applications in the pulp and paper industry. 5th IFAC/IFIP International Conference on the Digital Computer Applications to Process Control, Den Haag, Netherlands.
- Gerold, D., and H. Kurth. 1977. Anregungen zur Weiterentwicklung des Normalwaldmodells. *Wissenschaftliche Zeitschrift der Technischen Universität Dresden*, 26, Heft 2, 497-501.
- Gibson, D.F. 1975. Conceptual planning model for multiple use forest management. Systems Analysis and Forest Resource Management. Proceedings of a Workshop. Athens: Society of American Foresters, University of Georgia, August 11-13.
- Golemanov, L.A. 1972. Systems Theoretical Approach in the Projecting and Control of Industrial Production Systems. Helsinki: Ekono.
- Gustafson, M.L., and D.G. Schneck. 1975. Modeling harvesting systems. Systems Analysis and Forest Resource Management. Proceedings of a Workshop. Athens: Society of American Foresters, University of Georgia, August 11-13.

- Hagg, A. 1973. A Linear Programming Model for Short-Term Planning of Saw-Log Acquisition: Sawmill Production and Sales, Stockholm: Skogshögskolan (in Swedish).
- Hammer, L.N. 1975. WRAP: A multiple resource model for allocation of wildland resources. Systems Analysis and Forest Resource Management. Proceedings of a Workshop, Athens: Society of American Foresters, University of Georgia, August 11-13.
- Henne, A. 1978. Nutzwertanalyse. Proceedings of Steering Systems Project Group, IUFRO, Bucharest, June 18-24.
- Holley, D.L. Jr. 1977. Regional aspects of long-range planning in forestry. In Forestry and Long-Range Planning, edited by F.J. Convery and C.W. Ralston, Durham, N.C.: School of Forestry and Environmental Studies, Duke University.
- Hyde, W.F. 1979. Implications of economic forest management. Policy Analysis, Vol. 5, No. 3.
- Jegr, M.M., E.R. Miller, and K.M. Thompson. 1978. PAPRISIM II: A Dynamic Model of the Canadian Pulp and Paper Industry. Pointe Claire, P.G.: Pulp and Paper Research Institute of Canada.
- Jobstl, H.A. 1973. A planning model with special attention to sustained yield. Centralblatt fuer das gesamte Fortswesen, 90, 4 (in German).
- Johnson, K.N., and H.L. Scheurman. 1977. Techniques for prescribing optimal timber harvest and investment under different objectives--discussion and synthesis. Forest Science Monograph, Utah State University, Logan, Utah, No. 18.
- Johnson, N., L. Scheurman, and J. Beuter. 1975. Oregon timber resource model: a brief introduction. Systems Analysis and Forest Resource Management. Proceedings of a Workshop. Athens: Society of American Foresters, University of Georgia, August 11-13.
- Kallio, M., A. Propoi, and R. Seppälä. 1980. A Model for the Forest Sector. Laxenburg, Austria: International Institute for Applied Systems Analysis (IIASA) (WP-80-34).
- Keane, J.T. 1975. Optimization theory and forest systems. Systems Analysis and Forest Resource Management. Proceedings of a Workshop. Athens: Society of American Foresters, University of Georgia, August 11-13.
- Keyes, M.A. 1975. Computer control census. Tappi, Vol. 58, No. 6.
- Kilkki, P., R. Pökälä, and M. Siitonen. 1975. Linear programming in the planning of timber production in a forestry unit. Silva Fennica, Vol. 9, No. 2, 170-180 (in Finnish).



- Kirby, M. 1975. Land use planning, transportation planning and integer programming. Systems Analysis and Forest Resource Management. Proceedings of a Workshop. Athens: Society of American Foresters, University of Georgia, August 11-13.
- Kirby, M. 1978. Large-scale budget applications of mathematical programming in the forest service. Proceedings of Steering Systems Project Group, IUFRO, Bucharest, June 18-24.
- Kolenka, I. 1978. Optimal control of raw timber production processes. Proceedings of Steering Systems Project Group, IUFRO, Bucharest, June 18-24.
- Lampi, A.O., and N.S. Adams. 1975. Application of the GELO mapping system in region 6, USFS. Systems Analysis and Forest Resource Management. Proceedings of a Workshop. Athens: Society of American Foresters, University of Georgia, August 11-13.
- Larson, F.R. 1975. Simulating growth and management of ponderosa pine stands. Systems Analysis and Forest Resource Management. Proceedings of a Workshop. Athens: Society of American Foresters, University of Georgia, August 11-13.
- Lebelt, W., and C.H. Richter. 1972. Modell eines optimalen Planes der Faresholzbereitstellung unter den Bedingungen des direkt-transportes. Sozialistische Forstwirtschaft 22, 3.
- Lembersky, M.R. 1975. Independence of maximum average annual volume from initial stand condition. Systems Analysis and Forest Resource Management. Proceedings of a Workshop. Athens: Society of American Foresters, University of Georgia, August 11-13.
- Leiviskä, K., and P. Uronen. 1979a. Dynamic optimization of a sulphate mill pulp line; comparison of automatic control and operational research techniques applied to large systems analysis and control. IFAC/IFORS Symposium, March 6-8, preprints, 25-32, Toulouse.
- Leiviskä, K., and P. Uronen. 1979b. Dynamic optimization of a sulphate pulp mill. IFAC Symposium Optimization Methods, Applied Aspects, 15-19 X, preprints 291-300, Varna.
- Leuschner, W.A., J.R. Porter, M.R. Reynolds, and H.E. Burkhart. 1975. A linear programming model for multiple use planning. Canadian Journal for Forestry Resources, Vol. 5.
- Lund, H.G., and M. Kniesel, Jr. 1975. Multiple resource inventory system. Systems Analysis and Forest Resource Management. Proceedings of a Workshop. Athens: Society of American Foresters, University of Georgia, August 11-13.

- Lundeen, L.J. 1975. Resource allocation analysis and land use applications. Systems Analysis and Forest Resource Management. Proceedings of a Workshop. Athens: Society of American Foresters, University of Georgia, August 11-13.
- Lundgren, A.L., and B.L. Essex. 1978. A computerized tree growth projection system for forest resource evaluation in the lake states. Proceedings of Steering Systems Project Groups, IUFRO, Bucharest, June 18-24.
- McDonough, J.M., and D.E. Park, Jr. 1975. Nonlinear optimal control approach to interregional management of timber production and distribution. Systems Analysis and Forest Resource Management. Proceedings of a Workshop. Athens: Society of American Foresters, University of Georgia, August 11-13.
- Mitchell, T.R. 1976. A Control Systems Approach to Forest Resource Management. Lansing, Michigan: University of Michigan.
- Muench, J. Jr. 1977. Collective approaches to long range planning in forest industry. In Forestry and Long-Range Planning, edited by F.J. Convery and C.W. Ralston, Durham, N.C.: School of Forestry and Environmental Studies, Duke University.
- Muller, R.A. 1978. A model of canadian pulp and paper industry. Canadian Journal of Economics, Vol. 11, No. 2.
- Murphy, P.A. 1976. Ranking forestry investments with parametric linear programming. USDA Forest Service Research Paper, No. 50-117.
- Myers, C.A. 1974. Computerized preparation of timber management plans; TEVAP2. USDA Forest Service Research Paper, No. RM-115.
- Navon, D.I. 1971. Timber RAM...a long range planning method for commercial timber lands under multiple-use management. USDA Forest Service Research Paper PSW-70.
- Navon, D.I. 1975. Short-run and long-run models for planning forest transportation. Systems Analysis and Forest Resource Management. Proceedings of a Workshop. Athens: Society of American Foresters, University of Georgia, August 11-13.
- Navon, D.I. 1976. A stratified planning strategy for wildlands. XVI IUFRO World Congress, Proceedings, 428-438, Oslo.
- Neiman, R.E. 1976. The Use of Profitability Analysis to Optimize Pulp and Paper Capital Projects. Tappi Engineering Conference, Book II, 83-93.
- Nelson, D.H. 1975. Developing interactive computer graphics for geographic information. Systems Analysis and Forest Resource Management. Proceedings of a Workshop. Athens: Society of American Foresters, University of Georgia, August 11-13.

- Nesterov, V.G., and E.V. Avtukhovich. 1974. Optimization of the selection of areas for thinning by the methods of dynamic programming. *Lesnoi Zhurnal*, 17, 4 (in Russian).
- Newnham, R.M. 1973. Process control in forest harvesting. *The Forestry Chronicle*, February, 35-40.
- Newnham, R.M. 1975. LOGPLAN: A Model for Planning Logging Operations. Information Report. Forest Management Institute, Canada.
- Norström, C.J. 1975. A stochastic model for the growth period decision in forestry. *Swed. Journal of Economics*, 329-337.
- Odendahl, W.F. 1975. Transportation analysis and modeling for forest resource management. *Systems Analysis and Forest Resource Management. Proceedings of a Workshop. Athens: Society of American Foresters, University of Georgia, August 11-13.*
- Oliveira, R.A., J. Buongiorno, and A.M. Kmiotek. 1977. Time-series forecasting models of lumber cash, futures, and basis prices. *Forest Science*, Vol. 23, No. 2.
- O'Regan, W.G., S. Nozaki, and N.E. Savin. 1975. Stochastic fire-front forecasting from reconnaissance-based estimates of rate-of-fire spread. *Systems Analysis and Forest Resource Management. Proceedings of a Workshop. Athens: Society of American Foresters, University of Georgia, August 11-13.*
- Pabst, H. 1978. Estimating the value of non-economic forest functions. *Forst-und Holzwirtschaft*, 30, 2.
- Palo, M. 1971. Planning forestry projects by means of network analysis. *Folia Forestalia, Institutum Forestal Fenniae*, No. 133.
- Pettersson, E., and H. Rückert. 1978. Total Computerized Production Control. *PPI*, April, 77-82.
- Phillips, W.W., and T.J. Corcoran. 1978. Wood transportation systems, a spin-off of a computerized information and mapping technique. *Proceedings of Steering Systems Project Group Meeting, IUFRO, Bucharest, June 18-24.*
- Price, D.H.R. 1977. Construction of a Continuous Simulation Model of the UK Paper Industry and its Use as a Policy Testing and Assessment Tool. Ph.D. thesis, Bradford University, System Dynamics Research Group, Yorks.
- Rafsnider, G.T. 1975. Applicability of leontief multipliers in economic analysis of natural resource development. *Systems Analysis and Forest Resource Management. Proceedings of a Workshop. Athens: Society of American Foresters, University of Georgia, August 11-13.*

- Rajagopal, S. 1978. System simulation in forest engineering. Transactions of the ASAE, 802-805.
- Randers, J., and L. Lönnstedt. 1979. Transition strategies for the forest sector. Futures, June, 195-205.
- Randers, J., L. Stenberg, and K. Kalgraf. 1978. The Forest Sector in Transition. Oslo: J.W. Cappelen's Forlag (in Norwegian).
- Robinson, V.L. 1974. An econometric model of softwood lumber and stumpage markets 1947-1967. Forest Science, Vol. 20, No. 2.
- Rogers, M. 1979. Investment cycle theory of the paper industry. Tappi, Vol. 62, No. 1.
- Rogers, N.K. 1972. Uses of computer simulation techniques to help solve pulpwood harvesting and transportation problems. Tappi, Vol. 55, No. 5.
- Row, C. 1977. Forestry commodity projection methodology and long-range planning: a national perspective. In Forestry and Long-Range Planning, edited by F.J. Convery and C.W. Ralston, Durham, N.C.: School of Forestry and Environmental Studies, Duke University.
- Ruprich, J. 1974. The use of dynamic programming in forestry. Lesnictvi, 20, 1 (in Czechoslovakian).
- Rustagi, K.P. 1976. Forest Management Planning for Timber Production: A Goal Programming Approach, Bulletin No. 89, Yale University School of Forestry and Environmental Studies.
- Rustagi, K.P. 1978. Forest management planning for timber production; a sequential approach. Proceedings of Steering Systems Product Group Meeting, IUFRO, Bucharest, June 18-24.
- Schuler, A.T., 1975. Multiple Use Resource Management on National Forests via Goal Programming. Ph.D. thesis, Iowa State University.
- Schuler, A., and J.C. Meadows. 1975. Planning resource use on national forests to achieve multiple objectives. Journal of Environmental Management, Vol. 3, No. 4.
- Schwarzbart, G., E. Hirsch, T. Lennon, J.R. Robertson, and E. Rockey. 1975. Benchmark tests on mapping systems used by the US forest service. Systems Analysis and Forest Resource Management. Proceedings of a Workshop. Athens: Society of American Foresters, University of Georgia, August 11-13.
- Stone, R.N., and H.E. Dickerhoff. 1977. Outlook for forest products trade and imports. Forest Products Journal, Vol. 27, No. 10.

- Stone, R.N., and J.F. Saeman. 1977. World demand and supply of timber products to the year 2000. *Forest Product Journal*, Vol. 27, No. 10.
- Storey, T.G. 1972. FOCUS: A computer simulation model for fire control planning. *Fire Technology*, 8, 2.
- Tedder, P.L., G.H. Weaver, and D.D. Kletke. 1978. Timber RAM and ECHO: Alternative harvest planning models for a southern forest. *South. Journal Appl. For.*, 2 (3).
- Tencer, A.I. 1977. Computer simulation as a tool for pulp and paper mill investment justification. *Tappi Alkaline Pulping/Secondary Fibers Conference Proceedings*, 39-52.
- Thevenon, M.J., and R.O. McMahon. 1974. A quarterly econometric model of international trade of kraft linerboard. *Tappi*, Vol. 57, No. 3.
- Ulrich, H. 1974. Aids to Decision-Making for Cooperative Planning Projects Involving Forestry and the Wood Industry; Exemplified by a Model of the Harvesting of Beech Pulpwood, Zurich: Eidgenossische Technische Hochschule (in German).
- Uronen, P., and T.J. Williams. 1978. Hierarchical Computer Control of an Integrated Pulp and Paper Mill. Report No. 111, West Lafayette, Indiana: Purdue Laboratory for Applied Industrial Control.
- Virtanen, J. 1972. Network analysis in planning (the building of) forest roads. *Belsingin Yliopiston Metsäteknologian laitor, Tiedonantoja No. 18* (in Finnish).
- Walker, J.K. 1975. ECHO: Solution technique for a nonlinear economic harvest optimization model. *Systems Analysis and Forest Resource Management. Proceedings of a Workshop.* Athens: Society of American Foresters, University of Georgia, August 11-13.
- Weintraub, A., and D.I. Navon. 1976. A forest management planning model integrating silvicultural and transportation activities. *Management Science*, Vol. 22, No. 12.
- Weir, I.C.A. 1972. Planning of wood production using systems analysis. *Appita*, Vol. 26, No. 2.
- Weisz, R.M., and R. Carder. 1975. Development of land use planning systems for national forest management: a status overview. *Systems Analysis and Forest Resource Management. Proceedings of a Workshop.* Athens: Society of American Foresters, University of Georgia, August 11-13.

Williams, D.H., and M.M. Yamada. 1975. Data aggregation for land management models--a programming approach. Systems Analysis and Forest Resource Management. Proceedings of a Workshop. Athens: Society of American Foresters, University of Georgia, August 11-13.

Zackrisson, U., L. Ekstrom, and A. Baudin. 1977. Forecasting: A Competitive Device. Paper Vol. 188, No. 7, 368-370, 383.

APPLICATION PART

THE COMPARATIVE ECONOMICS OF PLANTATION FORESTRY:

AN OVERVIEW\*

by Roger A. Sedjo\*\*

Introduction:

Although plantation forests make up only a small fraction of the world's total industrial wood supply, they are becoming increasingly important as the natural forests of the world decline reflecting utilization of the natural stands and/or land clearing for nonforest uses. As this process continues, greater portions of the remaining commercial forests represent regrowth, much of it as the result of the conscious intervention of man. Commercial plantation forests, those planted and actively managed for their commercial wood values, are gradually replacing the natural forests in many regions of the world.

Three types of major plantation activities can be characterized as occurring simultaneously across the world. First, in temperate regions that traditionally produced the majority of the world's industrial wood-- Northern Europe and North America--plantation forestry typically involves the utilization of indigeneous species. Second, other temperate regions that have not been traditionally major industrial wood producers are commonly utilizing exotic temperate climate species (largely North American) that exhibit rapid growth and desired merchantibility. Third, some tropical regions have found that exotic species (tropical pines, eucalyptus, gmelina) from

---

\* Presented at the IIASA Forestry Workshop, Laxenburg, Austria, January 8-12, 1980

\*\* Director, Forest Economics and Policy Program, Resources for the Future, Washington, D.C., U.S.A.



other tropical regions exhibit desirable growth and merchantability characteristics. While experience with exotic plantations in the tropics is limited, results thus far are so dramatic that some knowledgeable observers maintain that tropical regions will eventually become dominant wood suppliers.

Within this context this study will examine the economics of commercial plantations in various regions, including representatives of the three regional types discussed above, and make preliminary assessments of the comparative economics of products from a typical plantation forest with each region.

#### Plantation Experience:

Plantation forests of some type exist in almost every country. However, commercial plantations are important in only a relatively few regions. In Europe and North America--the world's major supply of industrial wood--the natural forests are gradually giving way to managed plantations. The process is most advanced in Europe, except for the USSR, where plantation forests have been maintained for hundreds of years. In North America plantation forests developed in the US South in the 1930s and have become increasingly important since World War II. Initially, U.S. plantations involved merely reforestation with little if any subsequent management. However, in recent years in the US South and Pacific Northwest commercial plantations, utilizing a range of practices, have become prevalent. By contrast, plantation forestry in Canada is still in its fledging stages due to the large inventories of natural forest still available.

Outside of Europe and North America, several regions have developed large plantation forests. New Zealand currently has about one million hectares in plantation forests, most of it in exotic conifer from North America. New Zealand is adding to these forests at a rate of some 50 thousand hectares per

year. Australia has also introduced exotic plantations, particularly conifers, on a large scale to provide for her domestic long fiber requirements. Plantation forestry of various types is under way in Japan, the Philippines, Indonesia and Malayasia. India has undertaken large scale plantation forestry activities. Turkey and Iran have also undertaken significant plantation activities with a view to commercial industrial outputs. Numerous parts of Africa have also been involved in various forestry schemes. Plantations have been created in Kenya and Tanzania in East Africa utilizing a variety of tropical conifer species. South Africa has undertaken large plantations of various species, particularly P. radiata. West Africa has been involved in plantation schemes utilizing eucalyptus, gmelina and tropical pines.

Of all the nontraditional producing areas of the globe, nowhere have commercial forest plantations become more important than in South America. Plantations of P. radiata have been in place in Chile for about 75 years. In recent years the planting activity in Chile has increased substantially. Significant plantation activity is also underway in Columbia, Surinam and Argentina. In Venezuela interest in large commercial plantations has become serious only within the past decade or less. However, the level of activity is substantial, involving hundreds of thousands of hatares, and the potential great due to the availability of large areas of land with few alternative uses. However, the country with the most active commercial forestry section is clearly Brazil. Within the past 10 years Brazil has planted some 3 to 3.5 million hatares of new plantation forests, both conifers and nonconifer. In addition, the potential for expansion is vast and every indication is that the Brazilians intend to continue this expansion.

Although plantations are still only a small fraction of the world's total forested area the current areas involved belie their true potential.

Industrial potential is the result of not only more land being converted into forest plantations, but also of the probable volumes of output. These are likely to be large, since the physical productivity of the plantation is usually large due to the likelihood of location in regions of high biological growth and also due to management practices which increase usable growth.

Many observers anticipate a growing scarcity of wood through the remainder of this century and into the next accompanied by an attendant rise in the relative price of wood products and the primary forest resource. Given these expectations it is certainly prudent to investigate the potential of plantation forests in meeting future demand and to recognize that the possibility of higher future real stumpage prices may provide incentives for forestry investments not previously economically justifiable.

#### Study Objectives:

The purpose of this study is to undertake a broad general analysis of the comparative economic potential of wood growing plantations in a number of locations around the globe\* for pulp and lumber production for major world markets. The study is not designed to evaluate specific sites or specific existing plantations, but rather to investigate the comparative economic potential for wood plantations in a number of world regions based upon the biological possibilities that are known or believed to exist, the locations of the regions with respect to major world markets, and the species and quality of the wood that can be produced. The focus of this analysis is economic as opposed to financial. A region may enhance or diminish the financial viability of investments in forest plantations by altering the set of taxes, subsidies, etc. that apply to that region. However, it is

---

\* The regions to be investigated include the Pacific Northwest of North America, the U.S. South, the Nordic countries, South Brazil, Amazonia, Central Brazil, West Africa, South Africa, New Zealand, Chile, Australia and Borneo.

our intention to focus upon the inherent economic fundamentals created by biological and locational considerations. Not only is the study focus economic, but it is directed at the economics of plantation forestry alone and not to the economics of pulp or sawmills. To maintain this perspective, the study will assume that nonwood production costs of pulp and sawmills are identical worldwide. This is in keeping with the objective of the study which is to provide a general assessment of the economics of timber growing production for world markets in the various regions of the globe selected. It should also be noted that since our study is directed at production for the world market, the economics of production for local or regional markets are ignored and may well be quite different from the study's findings for the world market.

The study makes no pretext of generating definitive results. The future is always uncertain and we see it at best darkly. Rather the objective of the study is to identify in a systematic fashion several important factors that will determine the economic viability of plantations in various regions around the globe for production of world markets, to investigate the trade-off between the identified important economic and biological factors, and to utilize existing data to assess, in a general fashion, the comparative economics of production in several potentially important regions. The analysis for regional potential utilizes the construction of a representative plantation for a region and hence is regionally but not site specific. It goes without saying that there is considerable variation between sites, even within a region, and hence the reader cannot apply the results of the study to a particular site in the absence of additional site specific analysis. Finally the study does not incorporate ecological and environmental considerations into the principal methodological approach. However, a chapter of the study will be devoted to an assessment of the state of current scientific thinking with

regard to the ecological and environmental implications of forest plantations, particularly in the tropics.

Conceptual Approach:

The conceptual approach treats the world market for pulp and lumber-- Japan, the Northeast U.S. and Western Europe--as a well integrated market where price differentials for the homogeneous commodities are wholly explained by transport and related costs. Transport costs are treated as a function of distance. Mills are distributed in various regions throughout the world and are part of fully integrated mill/plantation operations. For each region under investigation a representative plantation/mill complex is constructed. Since our focus is the plantation activity, we assume that mills are everywhere identical embodying identical technology and having identical nonwood costs including the desired return to capital. Such a perspective is necessary to allow the analysis to focus upon the economics of the plantation aspects of production rather than an intermixture of plantation and mill considerations. Utilizing the above "model" the implicit value of wood delivered to the mill can be deduced as the difference between the world market price of the commodity and the sum of the international transport costs plus the nonwood mill production costs. Harvest and local transport costs are removed from delivered wood costs to obtain the implicit price of stumpage.

Utilizing the implicit stumpage price for the various regional plantations together with specific information regarding the productivity and costs of the regionally representative plantation, an estimate of the discounted present value (DPV) of the various regional plantations can be obtained.

Two different production regimes will be examined, a) an operation that is directed solely to the production of bleached kraft pulp, and b) a production operation that views lumber as its major product with the thinnings and wood residuals being utilized for pulp production.

In addition, alternative scenarios will be examined which incorporate a wide array of assumptions. These will include in the most abstract (simple) form an analysis which focuses exclusively upon biological growth of a pulpwood operation focusing upon the importance of biological growth alone in a pulpwood plantation. Subsequently, international transportation costs will be introduced and the trade-offs between location, biological growth, and perhaps rotation length, will be examined holding other costs constant. Sensitivity analysis will be undertaken to determine the extent to which the results will vary as changes in growth rates, international transportation costs, and plantation costs occur. Systematically the analysis will introduce additional considerations which will add to the complexity of the analysis as they add to the analytical realism. This complexity will include integrate sawtimber/pulpwood plantations. In its most detailed form the analysis will incorporate regionally specific management costs for integrated plantation complexes with regionally specific biological production functions and plantation costs with international transport costs. Throughout, the focus will be upon the world market which is treated as well integrated.

Utilizing the above described conceptual approach, the analysis will estimate a unique discounted present value (DPV) for each regional, species, different set of production outputs, etc.

A ranking of DPV for each scenario will provide an estimate of the capitalized value of the particular forest site for timber production over a long time horizon. However, in itself, the DPV will not indicate the economic

viability of a particular site since land acquisition costs and plantation development costs have not been considered. An economic interpretation of the meaning of the various DPV is as follows: The DPV indicates the amount of initial investment that the rational investor should be willing to pay in order to bring that land into a forest plantation operation of the type discussed above, i.e. the price he is willing to pay for the asset. If the acquisition and development costs are equal to the DPV, the implication is that the project will return to the investor a percentage return equal to the discount rate used in the analysis. If the acquisition and development costs are less than the DPV, the return will be greater than the discount rate used in the analysis. If the acquisitions and development costs are greater than the DPV the project returns do not cover the opportunity costs of the land and capital required to get the plantation on stream. The analysis does not attempt to assess the development costs for each region since these costs would obviously be highly site specific. However, certain broad observations are made for the various regions based upon knowledge of that region acquired in undertaking this project.

Some Specifics:

The specific approach has several dimensions. First, a representative plantation is being developed for each of the regions, species, and plantation types under consideration. The object is to represent a typical or average plantation for the region. Each representative plantation will specify a production and management regime consistent with common practices in commercial plantations within the region. This will include species, major product (pulpwood or sawtimber), rotation length, biological growth rate, and a set and time profile of management practices (these include site preparation,

planting, cleaning, thinning, harvesting, etc.) utilizing available data, the costs of the various management activities will be identified. A region may have more than one representative plantation. For example, Southern Brazil has several possible representative plantations including a pine fiber plantation, a eucalyptus sawtimber plantation, etc. The same will be true for other regions. In all, perhaps 20-30 representative plantations will be constructed. However, we anticipate that the analysis will focus on a subset of these.

Second, a global matrix is being developed that relates world markets for pulp and sawtimber to the raw material supplies in the various plantations. As noted, the world markets for pulp and sawtimber are defined as being Japan, the U.S. Northeast, and Western Europe. Prices in these three markets are defined as not differing by more than the cost of transportation between them. Pacific Northwest Region of North America (PNW) establishes the baseline market prices with the world market prices equaling the PNW price plus transportation costs from the PNW to that region. The rationale for this procedure is that the PNW has traditionally competed simultaneously in the three segments of the world market under consideration.

For a particular commodity in the world market a concentric zone framework can be developed. For example, the mill price of the pulp at the plantation will equal the world market price minus transport costs. Therefore, as the plantation mill increases its distance from the relevant world market, the mill price of the pulp will decrease. Utilizing the above perspective and the knowledge of the nonwood costs, the residual can be assigned as the implicit wood price delivered to the mill. The subtraction of the harvests and transport costs leaves a residual that is the amount left for stumpage or the implicit stumpage value. To cite a specific example, suppose that the



world market price of long-fiber bleached kraft pulp is \$450 delivered to the world market. Suppose that the nonwood costs of production of a typical mill utilized worldwide is \$310. This figure would include not only the normal return to the capital but also the costs of the power, chemicals, labor, and other nonwood inputs. The residual, \$140, would be available to cover transportation costs to the world market and wood input costs delivered to the mill. If transport costs to a region were (say) \$50 per ton for pulp, a residual of \$90 per ton would be available to cover wood costs. One ton of pulp requires about  $4.7 \text{ m}^3$  of pine per ton of woodpulp, therefore, the implicit residual per  $\text{m}^3$  is \$19.15 per  $\text{m}^3$  at the mill. If harvest and wood transport costs to the mill are about \$12 per  $\text{m}^3$ , the implicit stumpage value is \$7.15 per  $\text{m}^3$ . Should pulp international transport costs rise from \$50 to \$75, only a \$65 residual would be available to cover delivered wood costs, i.e. \$13.83 per  $\text{m}^3$ . After \$12 has been removed for harvest and transport costs, a residual of only \$1.83 per  $\text{m}^3$  is available as the implicit stumpage value. Using this procedure estimates of regional stumpage prices can be obtained.

The above illustration demonstrates the importance of location and shows that an increase in transportation costs will directly impact upon the implicit stumpage value. Of course, to the extent that nonwood mill costs or harvest and delivery costs to mill are reduced, the residual value of the stumpage is increased.

Finally, the time profile of costs and outputs of the regional representative plantation will be combined with the estimate of regional stumpage value deduced from the transportation matrix to estimate a DPV for the various regions. Alternative scenarios based on different assumptions concerning costs, discount rates and future prices will be examined.

Appendix  
Comparative Economics of Timber Plantation  
Conceptual Approach

Overview

A. International and World  
Market Considerations

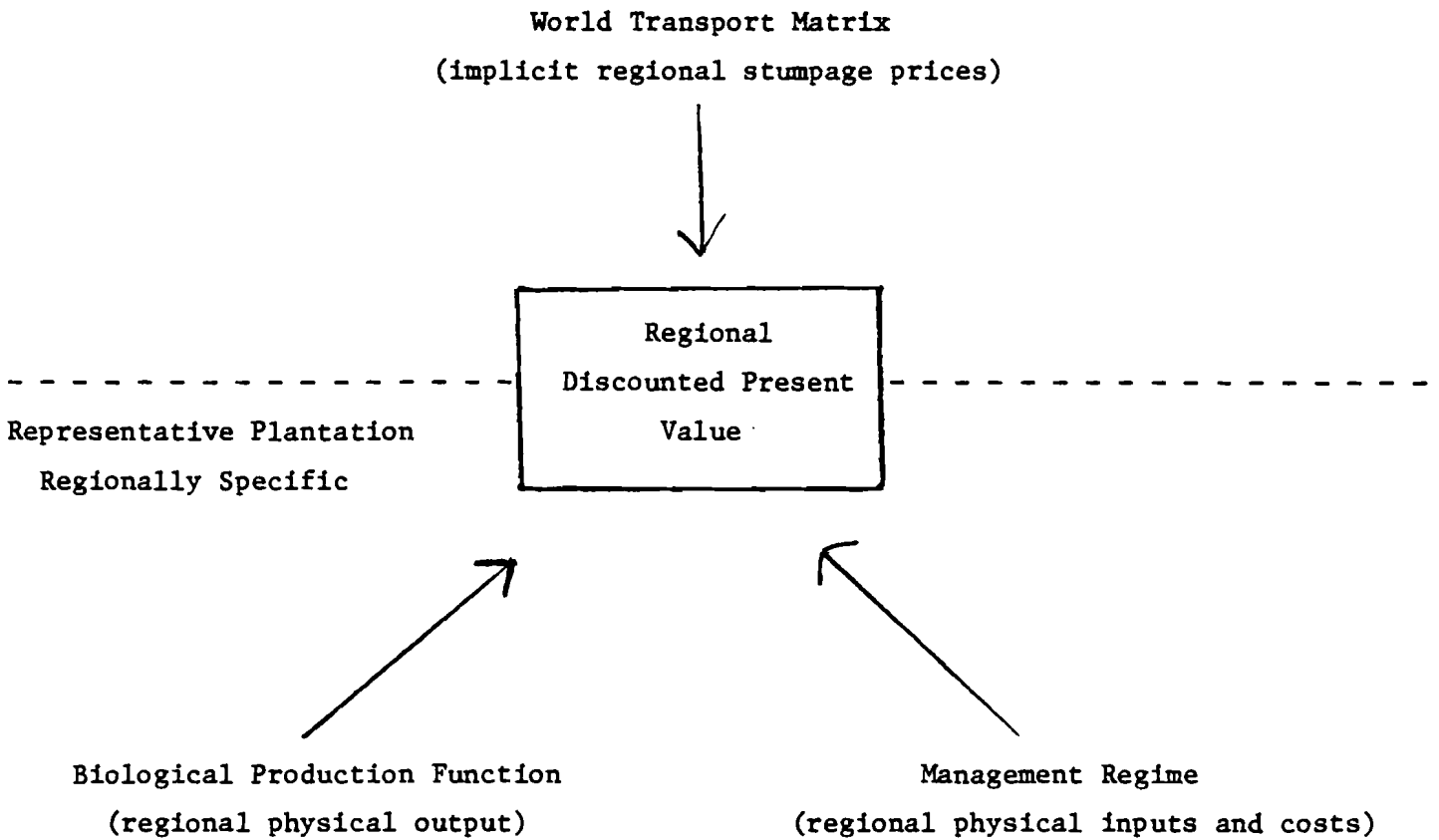

B. International and World Market Considerations

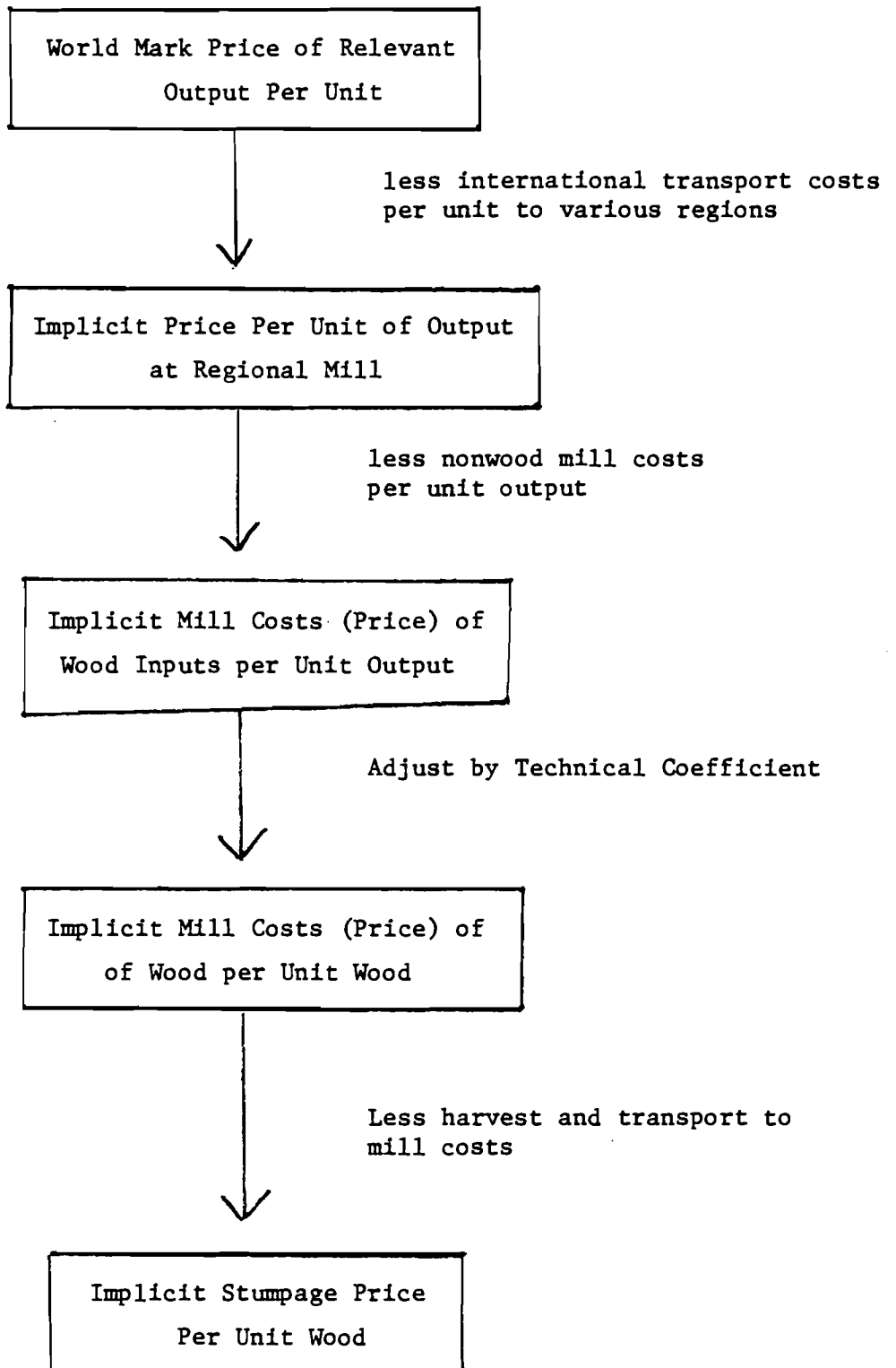

C. Biological Production Functions

Biological Growth is dependent upon:

- a) Region (average site conditions)
- b) Time
- c) Species
- d) Management practices

D. Management Regime and Costs

- a) Output mix desired
- b) Region
- c) Species
- d) Costs for region

E. Outputs

- Bleached Kraft pulp
- B. K. pulp and lumber

F. Regions (species)

- Pacific North West (Douglas Fir)
- U.S. South (Loblolly Pine)
- Nordic (Norway Spruce)
- Amazonia (Gmelina, Tropical Pine)
- Central Brazil (Eucalyptus)
- Southern Brazil (Loblolly Pine)
- Chile (P. Radiata)
- New Zealand (P. Radiata)
- Australia (P. Radiata)
- Borneo (Tropical Pine)
- South Africa (P. Radiata)
- West Africa (Gmelina)

A MODEL FOR THE FOREST SECTOR

M. Kallio  
A. Propoi  
R. Seppälä

#### ACKNOWLEDGMENTS

The authors wish to thank William Orchard-Hays for his help in implementing our forest sector model using the SESAME system, and Jari Kuuluvainen (of The Finnish Forest Research Institute), Heikki Seppälä (of The Finnish Forest Research Institute), and Margareta Soismaa (of the Helsinki School of Economics) for data collection. The work has benefited from discussions with George B. Dantzig (Stanford University), to whom we express our sincere gratitude.

Partial financial support has been received from The Academy of Finland.

## ABSTRACT

This paper describes a dynamic linear programming model for studying long-range development alternatives of forestry and forest based industries at a national and regional level. The Finnish forest sector is used as an object of implementation and for numerical examples. Our model is comprised of two subsystems, the forestry and the industrial subsystem, which are linked to each other through the wood supply. The forestry submodel describes the development of the volume and age distribution of different tree species within the nation or its subregions. In the industrial submodel we consider various production activities, such as saw mill industry, panel industry, pulp and paper industry, as well as further processing of primary products. For a single product, alternative technologies may be employed. Thus, the production process is described by a small Leontief model with substitution. Besides supply of wood and demand of wood products, production is restricted through labor availability, production capacity, and financial resources. The production activities are grouped into financial units and the investments are made within the financial resources of such units. Objective functions related to GNP, balance of payments, employment, wage income, stumpage earnings, and industrial profit have been formulated. Terminal conditions have been proposed to be determined through an optimal solution of a stationary model for the whole forest sector.

The structure of the integrated forestry-forest industry model is given in the canonical form of dynamic linear programs for which special solution techniques may be employed. Two versions of the Finnish forest sector models have been implemented for the interactive mathematical programming system called SESAME, and a few numerical runs have been presented to illustrate possible use of the model.

## A MODEL FOR THE FOREST SECTOR

M. Kallio, A. Propoi, and R. Seppälä

### 1. INTRODUCTION

As is the case with several natural resources, many regions of the world are now at the transition period from ample to scarce wood resources. Because the forest sector plays an important role in the economy of some countries, long-term policy analysis of the forest sector, i.e., forestry and forest industries, is becoming an important issue for these countries.

We may single out two basic approaches for analyzing long-range development of the forest sector: simulation and optimization. Simulation techniques (e.g., system dynamics) allow us to understand and to quantify basic relationships influencing the development of the forest sector (see Jegr et al. 1978, Randers 1976, Seppälä et al. forthcoming). Hence, using a simulation technique we can evaluate the consequences of a specific policy. However, using only simulation it is difficult to find a "proper" (or in some sense optimal) policy. The reason for this is that the forest sector is in fact a large-scale dynamic system and, on the basis of simulation alone, it is difficult to select an appropriate policy which should satisfy a large number of conditions and requirements. For this we need an optimization technique. Because of the complexity of the system in question,



linear programming (Dantzig 1963) may be considered as the most appropriate technique for this case. It is worthwhile to note that the optimization technique itself should be used on some simulation basis; i.e., different numerical runs based on different assumptions and objective functions should be carried out to aid the selection of an appropriate policy. Specific applications of such an approach for planning an integrated system of forestry and forest industries have been presented, for instance, by Jackson (1974) and Barros and Weintraub (1979).

Already because of the nature of growth of the forests, the model should necessarily be dynamic. Therefore, in this paper we consider a dynamic linear programming (DLP) model for the forest sector. In this approach the planning horizon (e.g., a 50-year period) is partitioned into a (finite) number of time periods (e.g., 5-year periods) and for each of these shorter periods we consider a static linear programming model. A dynamic LP is then just a linear program comprising of such static models which are interlinked via various state variables (i.e., different types of "inventories", such as wood in the forests, production capacity, assets, liabilities, etc., at the end of a given period are equal to those at the beginning of the following period). In our forest sector model, each such static model comprises two basic submodels: a forestry submodel, and an industrial model of production, marketing and financing. The forestry submodel describes also ecological and land availability constraints for the forest, as well as labor and machinery constraints for harvesting and planting activities.

The industrial submodel is described by a small input-output model with both mechanical (e.g., sawmill and plywood) and chemical (e.g., pulp and paper) production activities. Also secondary processing of the primary products will be included in the model, in particular, because of the expected importance of such activities in the future.

The rate of production is restricted by wood supply (which is one of the major links between the submodels), by final demand for wood products, by labor force supply, by production capacity availability, and finally, by financial considerations.

The evaluation criterion in comparing alternative policies for the forest sector is highly multiobjective: while selecting a reasonable long-term policy, preferences of different interest groups (such as government, industry, labor, and forest owners) have to be taken simultaneously into account. It should also be noted that forestry and industry submodels have different transient times: a forest normally requires a growing period of at least 40 to 60 years whereas a major structural change in the industry may be carried out within a much shorter period. Because of the complexity of the system, it is sometimes desirable to consider the forestry and the industries on some independent basis, each with its own objective(s), and to analyze an integrated model thereafter (see Kallio et al. 1979).

The paper is divided into two parts. In the first part (Sections 2-4) we describe the methodological approach. In the second part (Section 5) a specific implementation for the Finnish forest sector is described and illustrated with somewhat hypothetical numerical examples.

## 2. THE FORESTRY SUBSYSTEM

Mathematical programming is a widely applied technique for operations management and planning in forestry (e.g., Navon 1971, Dantzig 1974, Kilkki et al. 1977, Newnham 1975, Näslund 1969, Wardle 1965, Ware and Clutter 1971, Weintraub and Navon 1976, Williams 1976). In this section we follow a traditional formulation of the forests' tree population into a dynamic linear programming system. We describe the forestry submodel, where the decision variables (control activities) are harvesting and planting activities, and where the state of the forests is represented by the volume of trees in different species and age groups. Because the model is formulated in the DLP framework, we single out the following: (i) state equations which describe the development of the system, (ii) constraints which restrict feasible trajectories of the forest development, (iii) planning horizon, and (iv) objective function(s).

## 2.1 State Equations

Each tree in the forest is assigned to a class of trees specifying the age and the species of the tree. A tree belongs to age group  $a$  ( $a = 1, \dots, N-1$ ) if its age is at least  $(a-1)\Delta$  but less than  $a\Delta$ , where  $\Delta$  is a given time interval (for example, five years). In the highest age group  $a = N$  all trees are included which have an age of at least  $(N-1)\Delta$ . (Instead of age groups, we might alternatively assign trees to size groups specified by the trees' diameter.) We denote by  $w_{sa}(t)$  the number of trees of species  $s$ ,  $s = 1, 2, 3, \dots$ , (e.g., pine, spruce, birch, etc.) in age group  $a$  at the beginning of time period  $t$ ,  $t = 0, 1, \dots, T$ .

Let  $\alpha_{aa'}^s(t)$  show the ratio of trees of species  $s$  and in age group  $a$  that will proceed to the age group  $a'$  during time period  $t$ . We shall consider a model formulation where the length of each time period is  $\Delta$ . Therefore, we may assume that  $\alpha_{aa'}^s(t)$  is independent of  $t$  and equal to zero unless  $a'$  is equal to  $a+1$  (or  $a$  for the highest age group). We denote then  $\alpha_{aa'}^s(t) = \alpha_a^s$  with  $0 \leq \alpha_a^s \leq 1$ . The ratio  $1 - \alpha_a^s$  may then be called the attrition rate corresponding to time interval  $\Delta$  and tree species  $s$  in age group  $a$ . We introduce a subvector  $w_s(t) = \{w_{sa}(t)\}$ , specifying the age distribution of trees (number of trees) for each tree species  $s$  at the beginning of time period  $t$ . Assuming neither harvesting nor planting, the age distribution of trees at the beginning of the next time period  $t+1$  will then be given by  $\alpha^s w_s(t)$  where  $\alpha^s$  is the square  $N \times N$  growth matrix, describing aging and death of the trees resulting from natural causes. By our definition, it has the form

$$\alpha^s = \begin{bmatrix} 0 & 0 & & 0 \\ \alpha_1^s & 0 & & 0 \\ 0 & \alpha_2^s & & \\ \vdots & \vdots & \ddots & \vdots \\ 0 & \dots & \alpha_{N-1}^s & \alpha_N^s \end{bmatrix}$$

Introducing a vector  $w(t) = \{w_s(t)\} = \{w_{sa}(t)\}$ , describing tree species and age distribution and a block-diagonal matrix  $\alpha$  with submatrices  $\alpha^s$  on its diagonal, the species and age distribution at the beginning of period  $t+1$  will be given by  $\alpha w(t)$ .

We denote by  $u^+(t)$  and  $u^-(t)$  the vectors of planting and harvesting activities at time period  $t$ . The state equation describing the development of the forest will then be

$$w(t+1) = \alpha w(t) + \eta u^+(t) - \omega u^-(t) \quad , \quad (1)$$

where matrices  $\eta$  and  $\omega$  specify planting and harvesting activities in such a way that  $\eta u^+(t)$  and  $-\omega u^-(t)$  are the incremental change in numbers of trees resulting from planting and harvesting activities, respectively.

A planting activity  $n$  may be specified to mean planting of one tree of species  $s$  which enters the first age group ( $a = 1$ ) during period  $t$ . Thus, matrix  $\eta$  has one unit column vector for each tree species  $s$ . The nonzero element of such a column is on the row of the first age group for tree species  $s$  in equation (1).

A harvesting activity  $h$  is specified by variables  $u_h^-(t)$  which determine the level of this activity (e.g., final harvesting, thinning, etc.). The coefficients  $\omega_{ah}^s$  of matrix  $\omega$  are defined so that  $\omega_{ah}^s u_h^-(t)$  is the number of trees of species  $s$  from age group  $a$  harvested when activity  $h$  is applied at level  $u_h^-(t)$ . Thus, these coefficients show the age and species distribution of trees harvested when activity  $h$  is applied.

Sometimes the harvesting activities can be specified simply by the numbers of trees of species  $s$  and age  $a$  harvested during time period  $t$ . There is some danger in this specification, however, because the solution of the model may suggest that only one or very few age groups will be harvested at each time period  $t$ . This would of course be unrealistic in practice. Therefore, it is recommended that each harvesting activity is defined through a tree distribution corresponding to actual operations.

## 2.2 Constraints

Land. Let  $H(t)$  be the vector of total acreage of different types  $d$  of land available for forests at time period  $t$ . A land type  $d$  may refer, for instance, to a soil type. Let  $G_{ad}^s$  be the area of land species  $d$  required by one tree of species  $s$  and age group  $a$ . We assume that each tree species uses only one type of land  $d$ ; i.e., only one of the elements  $G_{ad}^s$ ,  $d = 1, 2, \dots$ , is nonzero. Thus, if we consider more than one land type, then the tree species  $s$  may also refer to the soil. Defining the matrix  $G = (G_{ad}^s)$ , we have the land availability restriction

$$Gw(t) \leq H(t) \quad . \quad (2)$$

In this formulation we assume that the land area  $H(t)$  is exogenously given. Alternatively, we may endogenize vector  $H(t)$  by introducing activities and a state equation for changing the area of different types of land. Such a formulation is justified if changes in soil type over time is considered or if some other land intensive activities, such as agriculture, are included in the model.

Besides land availability constraints, requirements for allocating land for certain purposes (such as preserving the forest as a water shed or as a recreational area) may be stated in the form of inequality (2). In such a case (the negative of) a component of  $H(t)$  would define a lower bound on such an allocation, while the left hand side would yield the (negative of) land allocated in a solution of the model.

Sometimes constraints on land availability may be given in the form of equalities which require that all land which is made available through harvesting at a time period should be used in the same time period for planting new trees of the type appropriate for the soil. Forest laws in many countries even require following this type of pattern.

Labor and other resources. Harvesting and planting activities require resources such as machinery and labor. Let  $R_{gn}^+(t)$  and  $R_{gh}^-(t)$  be the usage of resource  $g$  at the unit level

of planting activity  $n$  and harvesting activity  $h$ , respectively. Defining the matrices  $R^+(t) = \{R_{gn}^+(t)\}$  and  $R^-(t) = \{R_{gh}^-(t)\}$ , and vector  $R(t) = \{R_g(t)\}$  of available resources during period  $t$ , we may write the resource availability constraint as follows:

$$R^+(t)u^+(t) + R^-(t)u^-(t) \leq R(t) \quad . \quad (3)$$

Wood supply. The requirements for wood supply from forestry to industries can be given in the form:

$$S(t)u^-(t) = y(t) \quad , \quad (4)$$

where vector  $y(t) = \{y_k(t)\}$  specifies the requirements for different timber assortments  $k$  (e.g., pine log, spruce pulpwood, etc.), and matrix  $S(t)$  transforms quantities of harvested trees of different species and age into the volume of different timber assortments. Note that the volume of any given tree being harvested is assigned in (4) to log and pulpwood in a ratio which depends on the species and age group of the tree.

### 2.3 Planning Horizon

The forest as a system has a very long transient time: one rotation of the forest may in extreme conditions require more than one hundred years. Naturally, various uncertainties make it difficult to plan for such a long time horizon. On the other hand, if the planning horizon is too short we cannot take into account all the consequences of activities implemented at the beginning of the planning horizon. As a compromise we may think of a planning horizon of 50 to 80 years. Thus, if one period represents an interval of five years, the model will constitute 10 to 16 stages. It should be noted that such a planning horizon is unnecessarily long for the industrial subsystem and too short for the forestry subsystem. In order to eliminate the latter difficulty, it is desirable to analyze a stationary regime for the forests. In this case we set  $w(t+1) = w(t) = w$ , for all  $t$ . Similarly planting and harvesting activities are taken independent of time; i.e.,  $u^+(t) = u^+$  and  $u^-(t) = u^-$ , for all  $t$ . The state equation (1) can then be restated as

$$w = \alpha w + \eta u^+ - \omega u^- \quad (1a)$$

Imposing constraints (2) through (4) on variables  $w$ ,  $u^+$ , and  $u^-$ , we can solve the static linear programming problem and find an optimal stationary state  $w^*$  of the forest (and corresponding harvesting and planting activities). This approach has been used, for instance, by Rorres (1978) for finding the stationary maximum yield of a harvest. The solution of a dynamic linear program with terminal constraints

$$w(T) = w^*$$

yields the optimal transition to this stationary state.

Another way of introducing a stationary state is to consider an infinite period formulation and to impose constraints  $w(t) = w(t+1)$ ,  $u^-(t) = u^-(t+1)$  and  $u^+(t) = u^+(t+1)$ , for all  $t \geq T$ . If the model parameters for period  $t$  are assumed independent of time for all  $t \geq T$ , then the dynamic infinite horizon linear programming model may be formulated as a  $T+1$  period problem where the last period represents a stationary solution for periods  $t \geq T$ , and the first  $T$  periods represent the transition from the initial state to the stationary solution.

There is a certain difference in these two approaches of handling the stationary state. In the first approach, when (5) is applied, we first find the optimal stationary solution independently of the transition period, and thereafter we determine the optimal transition to this stationary state. In the latter approach we link the transition period with the period corresponding to the stationary solution. The linkage takes place in the stationary state variables which are determined in an optimal way taking into account both time periods simultaneously.

#### 2.4 Objective Functions

The forest management described above, has a very multi-objective nature. For example, the following objectives have been mentioned (Dantzig 1974, Steuer and Schuler 1978):

1) obtaining higher yields of round wood; 2) preserving the watershed; 3) preserving the forest as a recreational area; 4) making the forest resilient to diseases, fire, droughts, etc. Some of these objectives may be included in objective function(s), while others can be given as constraints. In Section 2.2 we considered some of these types of objectives as constraints.

A common objective which is also used as an objective function is the discounted sum of net income in forestry. This profit may be expressed as a linear combination of the decision variables:

$$\sum_{t=0}^{T-1} \beta(t) [J^-(t)u^-(t) - J^+(t)u^+(t)] \quad . \quad (6)$$

Here  $J^-(t)$  accounts for the mill price of the wood less transportation and harvesting costs at unit level. Vector  $J^+(t)$  refers to planting costs at unit level and  $\beta(t)$  is a discounting factor. For illustrative purposes we shall use this objective function for forestry.

## 2.5 Forestry Model

In summary, our forestry model may now be stated as follows. Given state equation (1), an initial state  $w(0) = w^0$  and a terminal state  $w(T) = w^*$ , find such nonnegative controls  $\{u^-(t)\}$  and  $\{u^+(t)\}$  ( $t = 0, 1, \dots, T-1$ ), which satisfy constraints (2) through (4), yield nonnegative state vectors  $w(t)$  and maximize the aggregated profit defined in (6).

In this problem the vector  $y(t)$  of wood supply, the (vector of) available land  $H(t)$ , and the availability of labor and other resources  $R(t)$  are given exogenously. Therefore, policy analysis for forestry on the basis of only this submodel is very limited in its possibilities. We shall link below this submodel with an industrial submodel describing transformation of wood raw material into products.



Note that our formulation may also be considered as a regionalized forestry model. In this case we only have to extend the meaning of various indices (tree species  $s$ , planting activity  $n$ , harvesting activity  $h$ , land type  $d$ , resource  $g$ , and timber assortment  $k$ ) to refer, in addition to the above, also to various subregions within the nation.

### 3. THE INDUSTRIAL SUBSYSTEM

We will now consider the industrial subsystem of the forest sector. Again the formulation is a dynamic linear programming model. We discuss first the section related to production and final demand of wood products, then the financial considerations and the complete industrial submodel thereafter.

#### 3.1 Production and Demand

Let  $x(t)$  be the vector (levels of) of production activities for period  $t$ , for  $t = 0, 1, \dots, T-1$ . Such an activity  $i$  may include production of sawn wood, panels, pulp, paper, converted products, etc. For each single product  $j$ , there may exist several alternative production activities  $i$  which are specified through alternative uses of raw material, technology, etc. Let  $U$  be the matrix of wood usage per unit of production activity so that the wood processed by industries during period  $t$  is given by vector  $Ux(t)$ . Note that matrix  $U$  has one row corresponding to each timber assortment  $k$  (corresponding to the components of supply vector  $y(t)$  in the forestry model). Some of the elements in  $U$  may be negative. For instance, saw milling consumes logs but produces raw material (industrial residuals) for pulp mills. This byproduct appears as a negative component in matrix  $U$ . We denote by  $r(t) = \{r_k(t)\}$  the vector of wood raw material inventories at the beginning of period  $t$  (i.e., wood harvested but not processed by the industry). As above, let  $y(t)$  be the amount of wood harvested in different timber assortments, and  $z^+(t)$  and  $z^-(t)$  the (vectors of) import and export of different assortments of wood, respectively during period  $t$ . Then we have the following state equation for the wood raw material inventory:

$$r(t+1) = r(t) + y(t) - Ux(t) + z^+(t) - z^-(t) \quad . \quad (7)$$

In other words, the wood inventory at the end of period  $t$  is the inventory at the beginning of that period plus wood harvested and imported less wood consumed and exported (during that period). Note that if there is no storage (change), and no import nor export of wood, then (7) reduces to  $y(t) = Ux(t)$ ; i.e., wood harvested equals the consumption of wood. For wood import and export we assume upper limits  $z^+(t)$  and  $z^-(t)$ , respectively:

$$z^+(t) \leq z^+(t) \quad \text{and} \quad z^-(t) \leq z^-(t) \quad . \quad (8)$$

The production process may be described by a simple input-output model with substitution. Let  $A(t)$  be an input-output matrix having one row for each product  $j$  and one column for each production activity  $i$  so that  $A(t)x(t)$  is the (vector of) net production when production activity levels are given by  $x(t)$ . Let  $m(t) = \{m_j(t)\}$  and  $e(t) = \{e_j(t)\}$  be the vectors of import from and export to the forest sector, respectively, for products  $j$ . Then, excluding from consideration a possible change in the product inventory, we have

$$A(t)x(t) + m(t) - e(t) = 0 \quad . \quad (9)$$

Both for export and for import we assume externally given bounds  $E(t)$  and  $M(t)$ , respectively:

$$e(t) \leq E(t) \quad , \quad (10)$$

$$m(t) \leq M(t) \quad . \quad (11)$$

Production activities are further restricted through labor and mill capacities. Let  $L(t)$  be the vector of different types of labor available for the forest industries. Labor may be classified in different ways taking into account, for instance, type of production, and the type of responsibilities in the production process (e.g., work force, management, etc.). Let  $\rho(t)$

be a coefficient matrix so that  $\rho(t)x(t)$  is the (vector of) demand for different types of labor given production activity levels  $x(t)$ . Thus we have

$$\rho(t)x(t) \leq L(t) \quad . \quad (12)$$

We will consider the production (mill) capacity as an endogenous state variable. Let  $q(t)$  be the vector of the amount of different types of such capacity at the beginning of period  $t$ . Such types may be distinguished by region (where the capacity is located), by type of product for which it is used and by different technologies to produce a given product. Let  $Q(t)$  be a coefficient matrix so that  $Q(t)x(t)$  is the demand (vector) for these types of capacity. Such a matrix has nonzero elements only when the region-product-technology combination of a production activity matches with that of the type of capacity. The production capacity restriction is then given as

$$Q(t)x(t) \leq q(t) \quad . \quad (13)$$

The development of the capacity is given by a state equation

$$q(t+1) = (I-\delta)q(t) + v(t) \quad , \quad (14)$$

where  $\delta$  is a diagonal matrix accounting for (physical) depreciation and  $v(t)$  is a vector of investments (in physical units). Capacity expansions are restricted through financial resources. We do not consider possible constraints of other sectors, such as heavy machinery or building industry, whose capacity may be employed in investments of the forest sector.

### 3.2 Finance

We will now turn our discussion to the financial aspects. We partition the set of production activities  $i$  into financial units (so that each activity belongs uniquely to one financial unit). Furthermore, we assume that each production capacity

is assigned to a financial unit so that each production activity employs only capacities assigned to the same financial unit as the activity itself.

Production capacity in (14) is given in physical units. For financial calculations (such as determining taxation) we define a vector  $\bar{q}(t)$  of fixed assets. Each component of this vector determines fixed assets (in monetary units) for a financial unit related to the capacity assigned to that unit. Thus, fixed assets are aggregated according to the grouping of production activities into financial units, for instance, by region, by industry, or by groups of industries.

Financial and physical depreciation may differ from each other; for instance, when the former is defined by law. We define a diagonal matrix  $(I-\bar{\delta}(t))$  so that  $(I-\bar{\delta}(t))\bar{q}(t)$  is the vector of fixed assets left at the end of period  $t$  when investments are not taken into account. Let  $K(t)$  be a matrix where each component determines the increase in fixed assets (of a certain financial unit) per (physical) unit of an investment activity. Thus the components of vector  $K(t)v(t)$  determine the increase in fixed assets (in monetary units) for the financial units when investment activities are applied (in physical units) at a level determined by vector  $v(t)$ . Then we have the following state equation for fixed assets:

$$\bar{q}(t+1) = (I-\bar{\delta}(t))\bar{q}(t) + K(t)v(t) \quad . \quad (15)$$

For each financial unit we consider external financing (long-term debt) as an endogenous state variable. Let  $\ell(t)$  be the (vector of) beginning balance of external financing for different financial units in period  $t$ . Similarly, let  $\ell^+(t)$  and  $\ell^-(t)$  be the (vectors of) drawings of debt and the repayments made during period  $t$ . In this notation, the state equation for long-term debt is as follows:

$$\ell(t+1) = \ell(t) + \ell^+(t) - \ell^-(t) \quad . \quad (16)$$

We will restrict the total amount for long-term debt through a measure which may be considered as a realization value of a financial unit. This measure is a given percentage of the total assets less short-term liabilities. Let  $\mu(t)$  be a diagonal matrix of such percentages, let  $b(t)$  be the (endogenous vector of) total stockholders equity (including cumulative profit and stock). Then the upper limit on loans is given as

$$[I - \mu(t)]l(t) \leq \mu(t)b(t) \quad . \quad (17)$$

Alternatively, external financing may be limited, for instance, to a percentage of a theoretical annual revenue (based on available production capacity and on assumed prices of products). Note that no repayment schedule has been introduced in our formulation, because an increase in repayment can always be compensated by an increase of drawings in the state equation (16).

Next we will consider the profit (or loss) from period  $t$ . Let  $p^+(t)$  and  $p^-(t)$  be vectors whose components indicate profits and losses, respectively, for the financial units. By definition, both profit and loss cannot be simultaneously nonzero for any financial unit. For a solution of the model, this fact usually results from the choice of an objective function.

Let  $P(t)$  be a matrix of prices for products (having one column for each product and one row for each financial unit) so that the vector of revenue (for different financial units) from sales  $e(t)$  outside the forest industry is given by  $P(t)e(t)$ . Let  $C(t)$  be a matrix of direct unit production costs, including, for instance, wood, energy, and direct labor costs. Each row of  $C(t)$  refers to a financial unit and each column to a production activity. The (vector) of direct production costs for financial units is then given by  $C(t)x(t)$ .

The fixed production costs may be assumed proportional to the (physical) production capacity. We define a matrix  $F(x)$  so that the vector  $F(t)q(t)$  yields the fixed costs of period  $t$  for the financial units. According to our notation above, (financial) depreciation is given by the vector  $\bar{\delta}(t)\bar{q}(t)$ .

We assume that interest is paid on the beginning balance of debt. Thus, if  $\epsilon(t)$  is the diagonal matrix of interest rates, then the vector of interest paid (by the financial units) is given by  $\epsilon(t)\ell(t)$ . Finally, let  $D(t)$  be (a vector of) exogenously given cash expenditure covering all other costs. Then the profit before tax (loss) is given as follows:

$$\begin{aligned}
 p^+(t) - p^-(t) = & P(t)e(t) - C(t)x(t) - F(t)q(t) \\
 & - \bar{\delta}(t)\bar{q}(t) - \epsilon(t)\ell(t) - D(t) \quad .
 \end{aligned}
 \tag{18}$$

The stockholder equity  $b(t)$ , which we already employed above, satisfies now the following state equation:

$$b(t+1) = b(t) + [I-\tau(t)]p^+(t) - p^-(t) + B(t) \quad , \tag{19}$$

where  $\tau(t)$  is a diagonal matrix for taxation and  $B(t)$  is the (exogenously given) amount of stock issued during period  $t$ .

Finally, we consider cash (and receivables) for each financial unit. Let  $c(t)$  be the vector of cash at the beginning of period  $t$ . The change of cash during period  $t$  is due to the profit after tax (or loss), depreciation (i.e., noncash expenditure), drawing of debt, repayment, and investments. Thus we assume that the possible change in cash due to changes in accounts receivable, in inventories (wood, end products, etc.) and in accounts payable cancel each other (or that these quantities remain unchanged during the period). Alternatively, such changes could be taken into account assuming, for instance, that the accounts payable and receivable, and the inventories are proportional to annual sales of each financial unit.

Using our earlier notation, the state equation for cash is now

$$\begin{aligned}
 c(t+1) = & c(t) + [I-\tau(t)]p^+(t) - p^-(t) + \bar{\delta}(t)\bar{q}(t) \\
 & + \ell^+(t) - \ell^-(t) - K(t)v(t) + B(t) \quad .
 \end{aligned}
 \tag{20}$$

### 3.3 Initial State and Terminal Conditions

In our industrial model, we now have the following state vectors: wood raw material inventory  $r(t)$ , (physical) production capacity  $q(t)$ , fixed assets  $\bar{q}(t)$ , long-term debt  $\ell(t)$ , cash  $c(t)$ , and total stockholders equity  $b(t)$ . For all of them we have an initial value and possibly a limit on the terminal value. We shall refer to the initial and terminal values by superscripts 0 and \*, respectively; i.e., we have the initial state given as

$$\begin{aligned} r(0) &= r^0, & q(0) &= q^0, & \bar{q}(0) &= \bar{q}^0, \\ \ell(0) &= \ell^0, & c(0) &= c^0, & b(0) &= b^0, \end{aligned} \tag{21}$$

and a terminal state restricted, for instance, as follows:

$$\begin{aligned} r(T) &\geq r^*, & q(T) &\geq q^*, & \bar{q}(T) &\geq \bar{q}^*, \\ \ell(T) &\leq \ell^*, & c(T) &\geq c^*. \end{aligned} \tag{22}$$

The initial state is determined by the state of the forest industries at the beginning of the planning horizon. The terminal state may be determined as a stationary solution similarly as we described for the forestry model above.

If we consider the wood supply  $y(t)$  being exogenous, we now have an industrial submodel which may be analyzed independently from the forestry submodel. A more complete discussion on objectives will be given in the next section, but for illustrative purposes, we may choose now the discounted sum of industrial profits (after tax) as an objective function:

$$\sum_{t=0}^{T-1} \beta(t) [(1-\tau(t))p^+(t) - p^-(t)] \tag{23}$$

Here  $\beta(t)$  is a (row) vector where components are the discounting factors for different financial units (for period  $t$ ).

### 3.4 Industrial Model

We may now summarize the industrial model. Given initial state (21), find nonnegative control vectors  $x(t)$ ,  $z^+(t)$ ,  $z^-(t)$ ,  $m(t)$ ,  $e(t)$ ,  $v(t)$ ,  $l^+(t)$ ,  $l^-(t)$ ,  $p^+(t)$ , and  $p^-(t)$ , and nonnegative state vectors  $r(t)$ ,  $q(t)$ ,  $\bar{q}(t)$ ,  $l(t)$ ,  $c(t)$ , and  $b(t)$ , for all  $t$  which satisfy constraints and state equations (7) - (20), the terminal requirements (22), and maximize the linear functional given in (23).

As was the case with the forestry model, our industrial model may also be considered being regionalized. Again various indices (such as production activities, production capacities, etc.) should also refer to subregions within the country. Various transportation costs will then be included in direct production costs. For instance for a given product being produced within a given region there may be alternative production activities which differ from each other only in the source region of raw material.

## 4. THE INTEGRATED SYSTEM

We will now consider the integrated forestry--forest industries model. First we have a general discussion on possible formulations of various objective functions for such a model. Thereafter, we summarize the model in the canonical form of dynamic linear programming. A tableau representation of the structure of the integrated model will also be given.

### 4.1 Objectives

The forest sector may be viewed as a system controlled by several interest groups or parties. Any given party may have several objectives which are in conflict with each other. Obviously, the objectives of one party may be in conflict with those of another party. For instance, the following parties may be taken into account: representatives of industry, government, labor, and forest owners. Objectives for industry may be the development of profit of different financial units. Government may be interested in the increment of the forest sector



to the gross national product, to the balance of payments, and to employment. The labor unions are interested in employment and total wages earned in forestry and different industries within the sector. Objectives for forest owners may be the income earned from selling and harvesting wood. Such objectives refer to different time periods  $t$  (of the planning horizon) and possibly also to different product lines. We will now give simple examples of formulating such objectives into linear objective functions.

Industrial profit. The vector of profits for the industrial financial units was defined above as  $[I-\tau(t)]p^+(t) - p^-(t)$  for each period  $t$ . If one wants to distinguish between different financial units, then actually each component of such a vector may be considered as an objective function. However, often we aggregate such objectives for practical purposes, for instance, summing up discounted profits over all time periods, summing over financial units, or as in (23), summing over both time periods and financial units.

Increment to gross national product. For the purpose of defining the increment of the forest sector to the GNP we consider the sector as a "profit center" where no wage is paid to the employees within the sector, where no price is paid for raw material originating from this sector, and where no taxes exist. The increment to the GNP is then the profit for such a center. We will now make a precise statement of such a profit which may also be viewed as the valued added in the forest sector.

Let  $P'(t)$  be a price vector so that  $P'(t)e(t)$  is the total revenue from selling wood products outside the forest sector. Let  $C'(t)$  be the vector of direct production unit costs excluding direct labor cost and cost of raw material which originates from the forest sector. Let  $\hat{R}(t)$  and  $\check{R}(t)$  be vectors of unit cost of planting and harvesting activities, respectively, excluding labor costs. For simplicity, we may assume that these latter two cost components include both operating and capital cost for machinery. The direct operating costs (excluding wages and wood based raw material) is then given, for period  $t$ , by

$C'(t)x(t) + \hat{R}(t)u^+(t) + \check{R}(t)u^-(t)$ . Also the import and export of wood based raw material influence the GNP. Let  $\hat{Z}(t)$  and  $\check{Z}(t)$  be price vectors for imported and exported wood raw material, respectively, and let  $M'(t)$  be the price vector of imported wood based products (to be used as raw material). Thus, the following term should be added to the GNP of period  $t$ :  $\check{Z}(t)z^-(t) - \hat{Z}(t)z^+(t) - M'(t)m(t)$ . The influence of the change in the wood inventory may be neglected in our model. For the fixed costs all except the labor costs will be taken into account. Let  $F'(t)$  be the vector of such costs per unit of production capacity, let  $\delta'(t)$  be the vector of depreciation factors, and  $\varepsilon'(t)$  the vector of interest rates (for various financial units). Then the negative increment of the fixed costs, depreciation and interest to the GNP is given by  $F'(t)q(t) + \delta'(t)\bar{q}(t) + \varepsilon'(t)\ell(t)$ . Summing up, the increment of the forest sector to the GNP of period  $t$  is given by the following expression:

$$P'(t)e(t) - C'(t)x(t) - \hat{R}(t)u^+(t) - \check{R}(t)u^-(t) - \hat{Z}(t)z^+(t) + \check{Z}(t)z^-(t) - M'(t)m(t) - F'(t)q(t) - \delta'(t)\bar{q}(t) - \varepsilon'(t)\ell(t).$$

Increment to balance of payments. The increment of the forest sector to the balance of payments has a similar expression to the one above for the GNP. The changes to be made in this expression are, first, to multiply the components of the price vector  $P'(t)$  by the share of exports in the total sales  $e(t)$ ; second, to multiply the components of the cost vectors  $C'(t)$ ,  $\hat{R}(t)$ ,  $\check{R}(t)$ , and  $F'(t)$  by the share of imported inputs in each cost term; third, to multiply each component of  $\varepsilon'(t)$  by the share of foreign debts (among all long-term debts) of the financial unit; and finally, to replace the depreciation function  $\delta'(t)\bar{q}(t)$  by investment expenditures  $K'(t)v(t)$ , where  $K'(t)$  is a vector expressing investments in imported goods (per unit of production capacity).

Employment. Total employment (in man-years per period) for each time period  $t$  for different types of labor, in different activities and regions, has already been expressed in the left

hand side expressions of inequalities (3) and (12). The expression for forestry is given by (part of the component of) the vector  $R^+(t)u^+(t) + R^-(t)u^-(t)$  and for the industry by the vector  $p(t)x(t)$ .

Wage income. For each group of the work force, the wage income for period  $t$  is obtained by multiplying the expressions for employment above by the annual salary of each such group.

Stumpage earnings. Besides the wage income for forestry (which we already defined above), and an aggregate profit (as expressed in (6)), one may account for the stumpage earnings; i.e., the income related to the wood price prior to harvesting the tree. Such income is readily obtained by the timber assortments if the components of the harvesting yield vector  $y(t)$  are multiplied by the respective wood prices.

#### 4.2 The Integrated Model

We will now summarize the integrated forestry-industry model in the canonical form of dynamic linear programming (Propoi and Krivonozhko 1978). Denote by  $X(t)$  the vector of all state variables (defined above) at the beginning of period  $t$ . Its components include the trees in the forest, different types of production capacity in the industry, wood inventories, external financing, etc. Let  $Y(t)$  be the nonnegative vector of all controls for period  $t$ , that is, the vector of all decision variables, such as levels of harvesting or production activities. An upper bound vector for  $Y(t)$  is denoted by  $\hat{Y}(t)$  (some of whose components may be infinite). We assume that the objective function to be maximized is a linear function of the state vectors  $X(t)$  and the control vectors  $Y(t)$ , and we denote by  $\gamma(t)$  and  $\lambda(t)$  the coefficient vectors for  $X(t)$  and  $Y(t)$ , respectively, for such an objective function. This function may be, for instance, a linear combination of the objectives defined above. The initial state  $X(0)$  is denoted by  $X^0$ , and the terminal requirement for  $X(T)$  by  $X^*$ . Let  $\Gamma(t)$  and  $\Lambda(t)$  be the coefficient matrices for  $X(t)$  and  $Y(t)$ , respectively, and let  $\xi(t)$  be the exogenous right hand side vector in the state equation for  $X(t)$ .

Let  $\phi(t)$ ,  $\Omega(t)$ , and  $\psi(t)$  be the corresponding matrices and the right hand side vector for the constraints. Then the integrated model can be stated in the canonical form of DLP as follows:

find  $Y(t)$ , for  $0 \leq t \leq T-1$ , and  $X(t)$ , for  $1 \leq t \leq T$ , to

$$\text{maximize } \sum_{t=0}^{T-1} (\gamma(t)X(t) + \lambda(t)Y(t)) + \gamma(T)X(T) \quad ,$$

subject to

$$X(t+1) = \Gamma(t)X(t) + \Lambda(t)Y(t) + \xi(t) \quad , \quad \text{for } 0 \leq t \leq T-1 \quad ,$$

$$\phi(t)X(t) + \Omega(t)Y(t) \hat{=} \psi(t) \quad , \quad \text{for } 0 \leq t \leq T-1 \quad ,$$

$$0 \leq X(t) \quad , \quad 0 \leq Y(t) \leq \hat{Y}(t) \quad , \quad \text{for all } t \quad ,$$

with the initial state

$$X(0) = X^0 \quad ,$$

and with terminal requirement

$$X(T) \hat{=} X^* \quad .$$

The notation  $\hat{=}$  for the constraints and terminal requirement refers either to  $=$ , to  $\leq$  or to  $\geq$ , separately for each constraint. The coefficient matrix (corresponding to variables  $X(t)$ ,  $Y(t)$ , and  $X(t+1)$ ) and the right hand side vector of the integrated forestry-industry submodel of period  $t$  are given as

$$\begin{bmatrix} -\Gamma(t) & -\Lambda(t) & I \\ \phi(t) & \Omega(t) & 0 \end{bmatrix} \quad \text{and} \quad \begin{bmatrix} \xi(t) \\ \psi(t) \end{bmatrix} \quad ,$$

respectively. Their structure has been illustrated in Figure 1 using the notation introduced in Sections 2 and 3.

	w	r	q	$\bar{q}$	l	b	c	u <sup>+</sup>	u <sup>-</sup>	y	x	z <sup>+</sup>	z <sup>-</sup>	m	e	v	l <sup>+</sup>	l <sup>-</sup>	p <sup>+</sup>	p <sup>-</sup>	
$-\alpha$								$-\eta$	$\omega$												= 0
	-I									-I	U	-I	I								= 0
		$\delta-I$														-I					= 0
			$\bar{\delta}-I$													-K					= 0
																	-I	I			= 0
																			$\tau-I$		= 0
																			$\tau-I$	I	= B
G				$-\bar{\delta}$			-I									K	-I	I	$\tau-I$	I	< H
								R <sup>+</sup>	R <sup>-</sup>												< R
								S	-I												= 0
										A		I	-I								= 0
										$\rho$											< L
										Q											< 0
																					> $-\mu B$
																					= -D
Upper bounds:												z <sup>+</sup>	z <sup>-</sup>	M	E						

Figure 1. The constraint matrix  $\begin{bmatrix} -\Gamma(t) & -\Lambda(t) \\ \Phi(t) & \Omega(t) \end{bmatrix}$ , the right hand side vector  $\begin{bmatrix} \xi(t) \\ \psi(t) \end{bmatrix}$ , the state vector  $X(t)$ , the control vector  $Y(t)$ , and the upper bound vector  $\hat{Y}(t)$  for the submodel of period  $t$  of the integrated forestry--industry model.

## 5. APPLICATION TO THE FINNISH FOREST SECTOR

### 5.1 Implementation

Two versions of the integrated model were implemented for the SESAME system (Orchard-Hays 1978) (a large interactive mathematical programming system designed for an IBM/370 and operating under VM/CMS). The model generators are written using SESAME's data management extension, called DATAMAT. An actual model is specified by the data tableaux of the generator programs.

Our two versions have been designed for the Finnish forest sector. Both of them may have at most ten time periods each of which is a five year interval. In each case, the country is considered as a single region. The main differences between our small and large version are in the number of products, financial units, and the tree species considered in the forest. Table 1 shows the dimensions of the two models.

For the small version, the seven product groups in consideration are sawn goods, panels, further processed mechanical wood products, mechanical pulp, chemical pulp, paper and board, and converted paper products. For each group we consider a separate type of production capacity and labor force. In this small version, we have aggregated all production into one financial unit. Only one type of tree represents all tree species in the forests. The trees are classified into 21 age groups. Thus, the interval being five years, the oldest group contains trees older than 100 years. Two harvesting activities were made available: thinning and final harvesting. The main timber assortments in consideration are log and pulpwood.

The larger version has the following 17 product groups: sawn goods, plywood, particle board, fiberboard, three types of further processed mechanical products, mechanical pulp, Si-pulp, Sa-pulp, newsprint, printing and writing paper, other papers, paperboard, and three types of converted paper products. Again for each such group we have a separate type of production capacity as well as labor force. The production is aggregated into seven

Table 1. Characteristic dimensions of the small and the large versions of the Finnish forest sector model.

	Small version	Large version
Number of time periods *	10	10
Length of one period in years *	5	5
Number of regions	1	1
Number of tree species	1	3
Number of age groups for trees*	21	21
Harvesting activities*	2	6
Soil types	1	1
Harvesting and planting resources	1	1
Timber assortments	2	6
Production activities	7	17
Types of labor in the industry	7	17
Types of production capacity	7	17
Number of financial units	1	7
Number of rows in a ten period LP	520	2320
Number of columns in a ten period LP	612	3188

\*The value may be specified arbitrarily by the model data. The numbers show the actual values being used.

financial units: saw mills, panels production (plywood, particle board, and fiberboard), further processing of primary mechanical wood products, mechanical pulp mills, chemical pulp mills, paper and board mills, and production of converted paper goods.

Three species of trees appear in the larger version: pine, spruce, and birch. For each of these we apply the same 21 age groups as in the small version. The two harvesting activities (thinning and terminal harvesting) and the two main timber assortments (log and pulpwood) are now considered separately for each of the three tree species.

The data for both of the versions of the Finnish model was provided by the Finnish Forest Research Institute. It is partially based on the official forest statistics (Yearbook of Forest Statistics 1977/1978) published by the same institute. Validation runs (which eventually resulted in our current formulation) were carried out by contrasting the model solutions with the experience gained in the preceding simulation study of the Finnish forest sector by Seppälä, Kuuluvainen and Seppälä (forthcoming).

## 5.2 Numerical Examples

For illustrative purposes we will now describe a few test runs: two with the small version and one with the larger one. Most of the data being used in these experiments corresponds approximately to the Finnish forest sector. This is the case, for instance, with the initial state; i.e., trees in the forests, different types of production capacity, etc. Somewhat hypothetical scenarios have been used for certain key quantities, such as final demand, and price and cost development. Thus, the results obtained do not necessarily reflect reality. They have been presented only to illustrate a few possible uses of the model.

For each test run a ten (five year) period model was constructed. Labor constraints both for industry and for forestry were temporarily relaxed. At this stage, no further processing activity for mechanical wood products but one activity for



converted paper products was considered. Both wood import and export were excluded, and pulp import to be used for paper production was allowed only in the larger version of the model. The assumed demand of wood products is given in Table 2. At the end of the planning horizon, we require that in each age group there is at least 80 percent of the number of trees initially in those groups. For production capacity a similar terminal requirement is 50 percent. Initial production capacity is given in Table 3 and the initial age distribution of trees in Figure 8 below.

For the first run the discounted sum of industrial profits (after tax) was chosen as an objective function. Such an objective may reflect the industry's behavior given the cost structure, price development, and other parameters. The results have been illustrated in Figures 2 through 7. The mechanical processing activities are limited almost exclusively by the assumed demand of sawn goods and panels. The same is true for converted paper products. However, both mechanical and chemical pulp produced is almost entirely used in paper mills, and therefore, the potential demand for export has not been exploited. Neither have the possibilities for exporting paper been used fully. As shown in Figure 5, paper export is declining sharply from the level of 5 million ton/year, approaching zero towards the end of the planning horizon. This is due to the strongly increasing production of converted paper products. The corresponding structural change of the production capacity of the forest industry over the 30 year period from 1980 to 2010 is given in Table 3. (The sudden decrease in production of panels and converted paper products is a "planning horizon effect" which often appears in dynamic LP solutions. Usually it is due to inappropriate accounting for the future in terminal conditions. For instance, in our case only a reasonable state was required at the end of the planning horizon, while an optimal stationary state might have been more appropriate.)

Table 2. Assumed annual demand of wood products in Runs 1 - 3.

Period	Sawn wood Mm <sup>3</sup> /y	Panels Mm <sup>3</sup> /y	Mech. pulp Mton/y	Chem. pulp Mton/y	Paper and board Mton/y	Converted paper prod. Mton/y
1980-84	7.0	1.7	.02	1.2	4.8	0.5
1985-89	7.5	2.0	.01	1.1	5.8	0.7
1990-94	8.0	2.2	.01	1.0	7.0	0.9
1995-99	8.8	2.5	.01	0.9	8.3	1.2
2000-04	9.3	2.8	.01	0.8	9.8	1.6
2005-09	9.7	3.2	.01	0.7	11.6	2.1
2010-14	10.2	3.6	.01	0.7	13.2	2.9
2015-19	10.7	4.1	.01	0.6	15.1	3.8
2020-24	11.2	4.6	.01	0.6	17.1	5.1
2025-29	11.6	5.2	.01	0.6	19.2	6.9

Table 3. Production capacity initially and in 2010 according to Runs 1 - 3.

Product	Production capacity				Unit
	Initial	Year 2010			
		Run 1	Run 2	Run 3	
Sawn wood	7.0	10.2	10.2	10.2	M m <sup>3</sup> /year
Panels	1.7	3.6	3.6	3.6	M m <sup>3</sup> /year
Mechanical pulp	2.2	1.9	2.2	0.5	M ton/year
Chemical pulp	4.0	4.3	5.8	5.0	M ton/year
Paper (and board)	6.2	6.2	7.3	8.7	M ton/year
Converted paper and board products	0.5	2.9	2.9	2.9	M ton/year

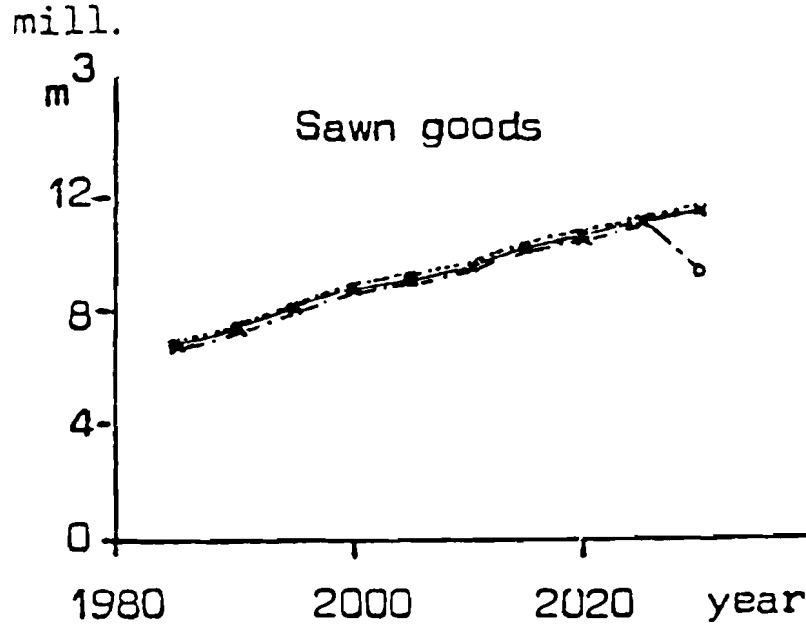
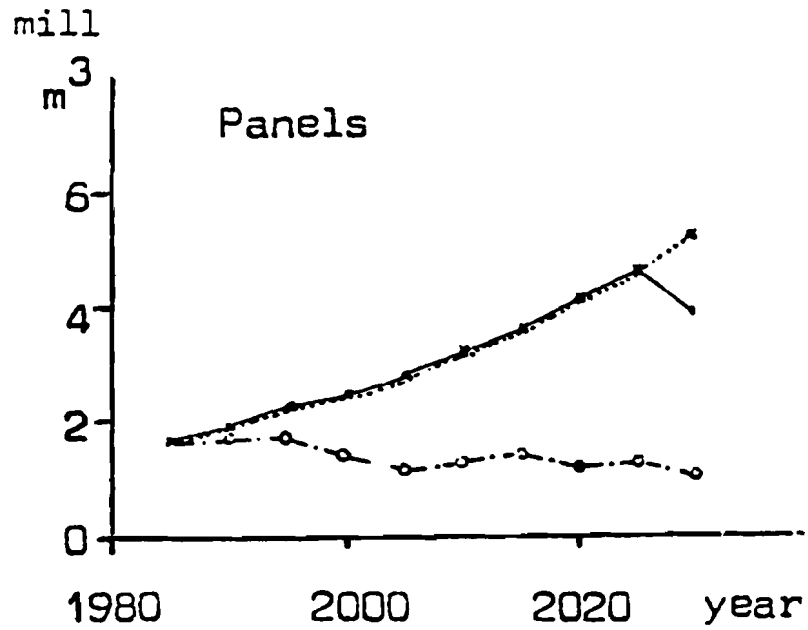

Run1: ●—● Run2: x.....x Run3: ○- -○

Figure 2. Annual production of sawn wood and panels (in millions of m<sup>3</sup> per year).

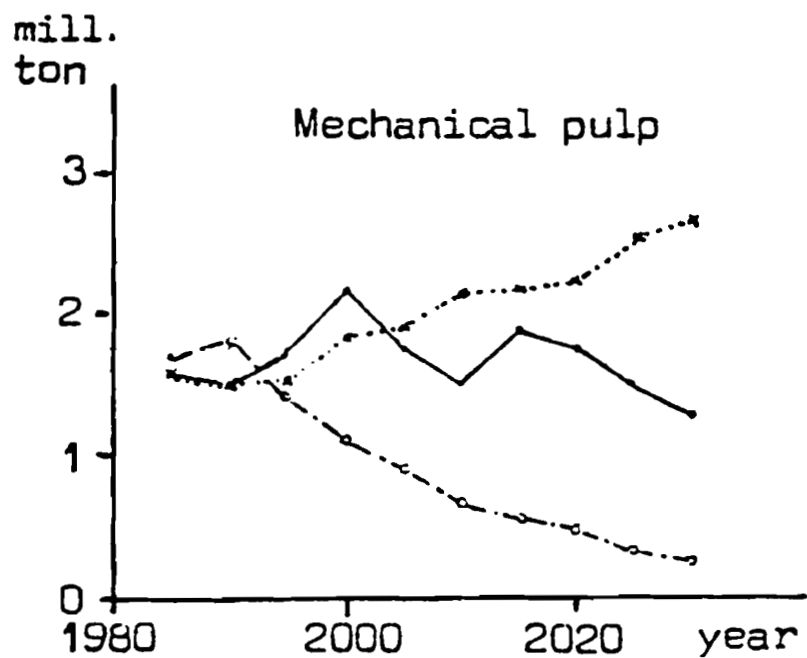
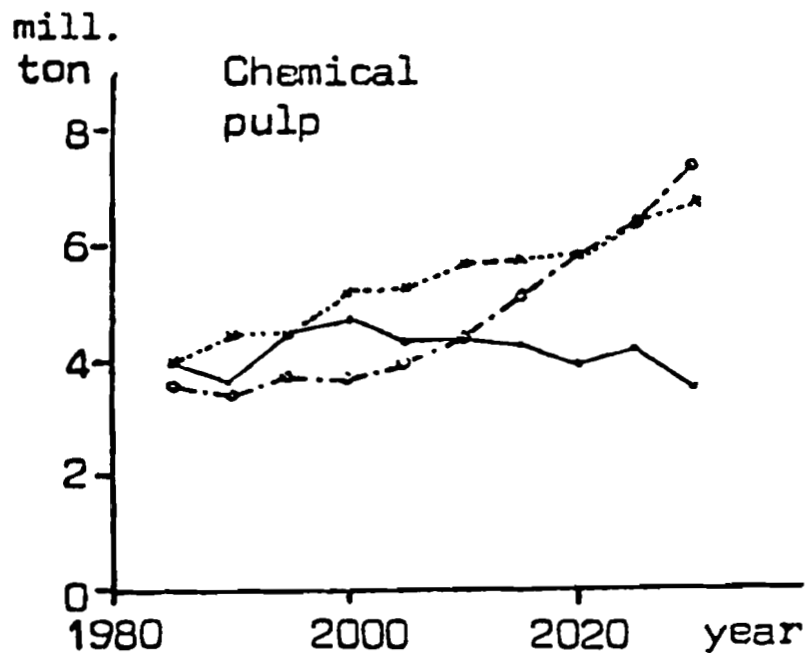

Run1: —●—    Run2: \*...\*    Run3: -.-●-

Figure 3. Annual production of pulp (in millions of ton per year).

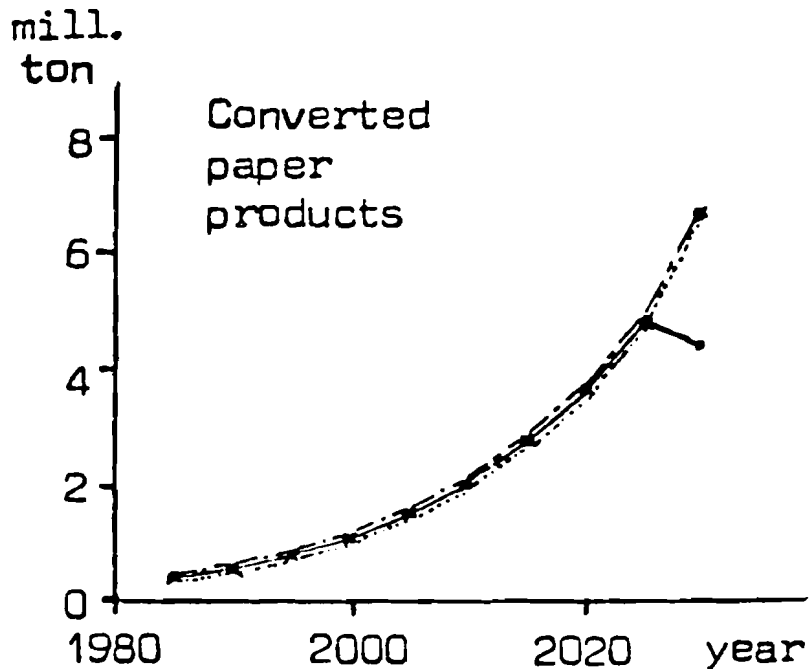
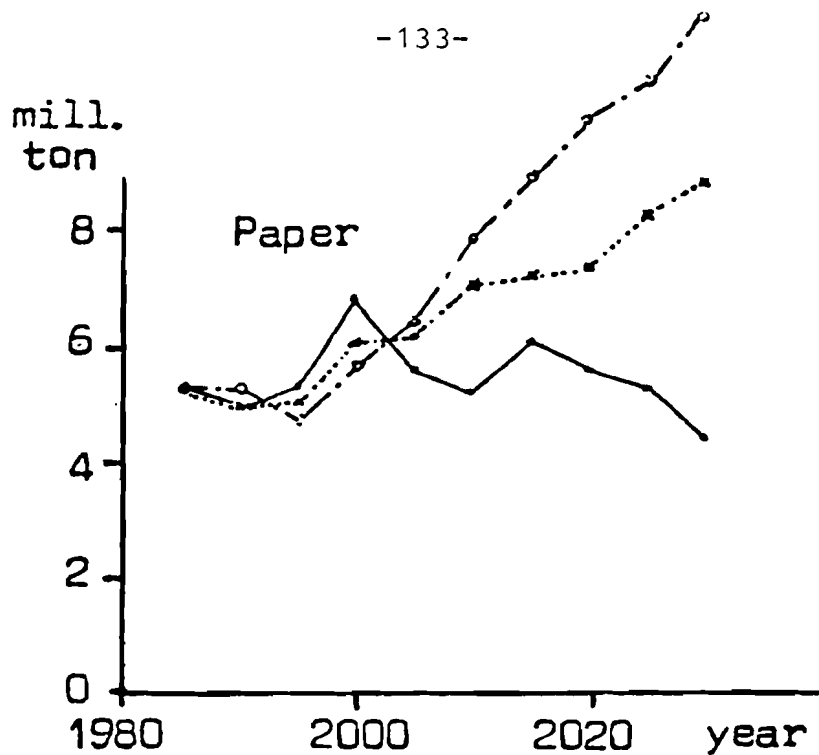

Run1: —●— Run2: ×····× Run3: -.-.-

Figure 4. Annual production of paper and converted paper products (in millions of ton per year)

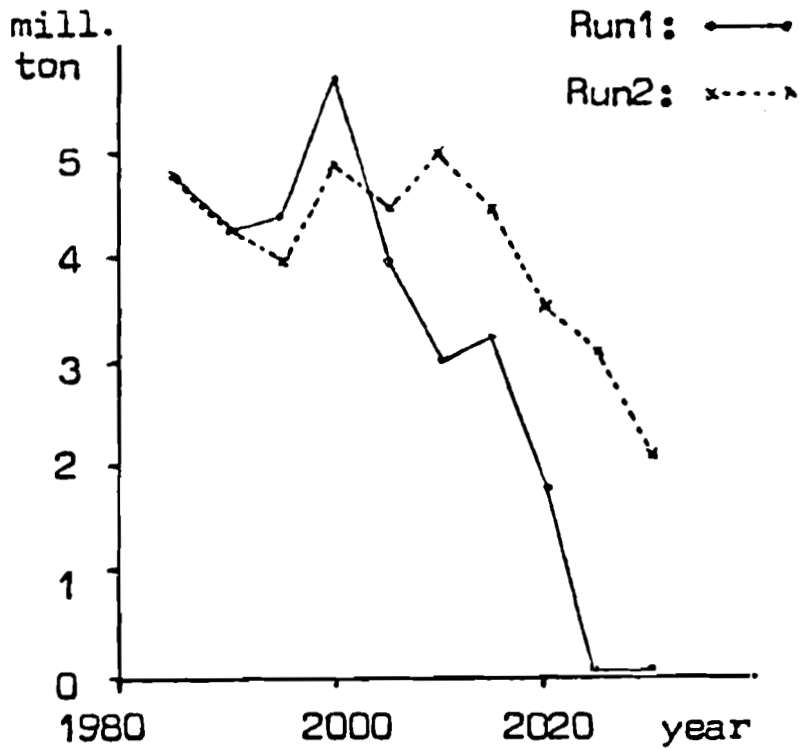

Figure 5. Paper export (in millions of ton per year)

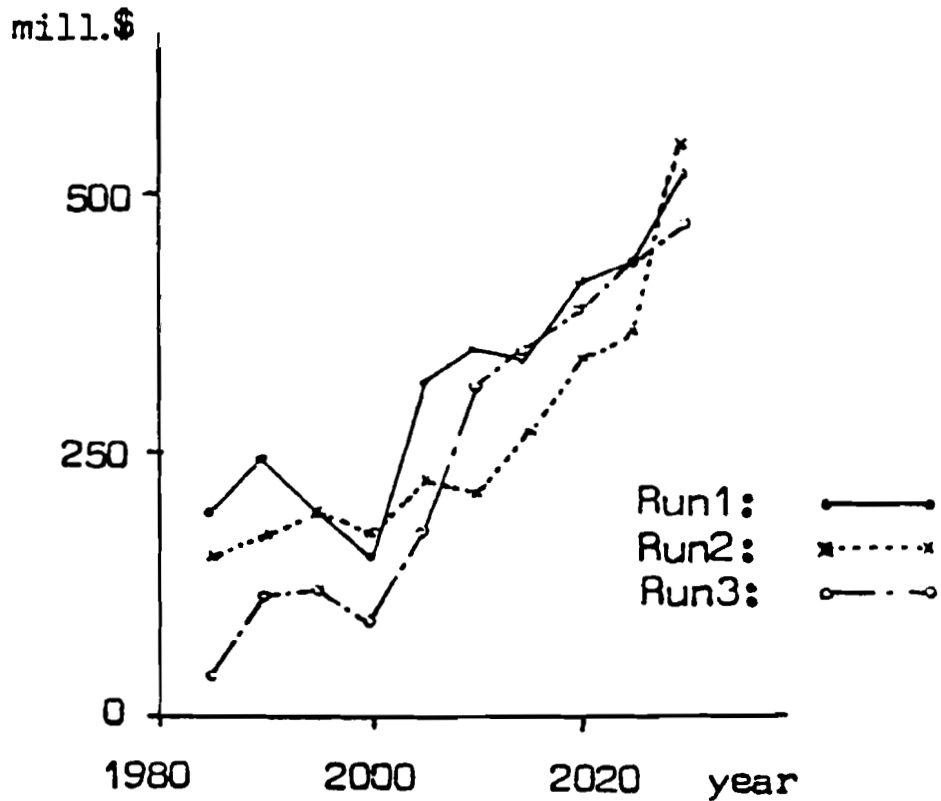

Figure 6. Industrial profit (in millions of dollars per year).

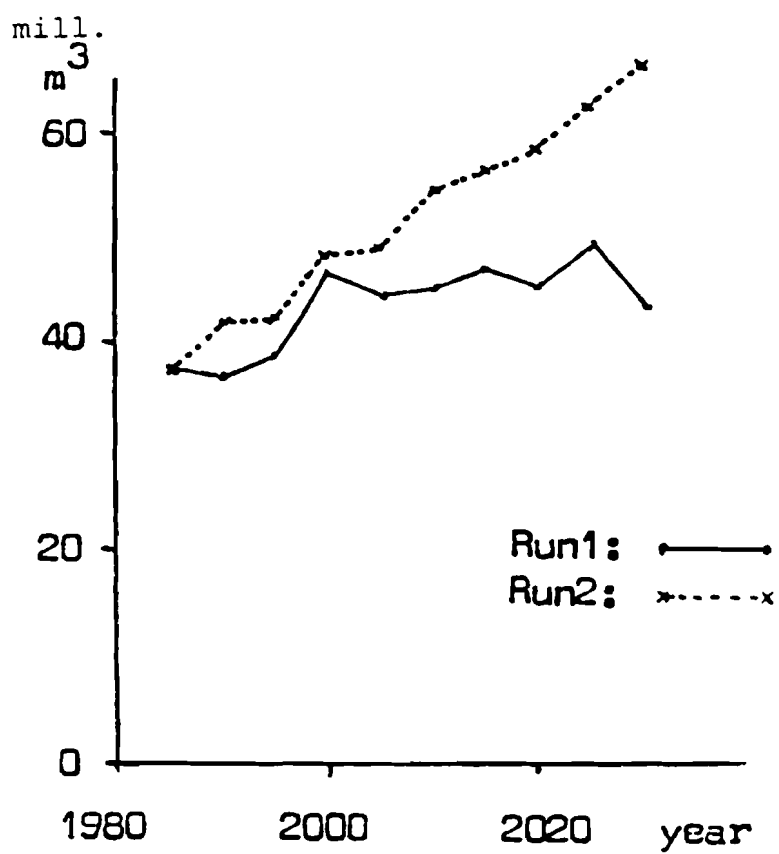

Figure 7. Industrial use of round wood (in millions of m<sup>3</sup> per year).

The use of wood has been shown in Figure 7. At the beginning the industrial use of wood increases from about 40 million  $m^3$ /year to the level of 45 million  $m^3$ /year and stays rather steadily there. According to Figure 6, the industrial profit increases from the annual level of .2 billion dollars towards the end of the planning horizon to around .5 billion dollars per year.

For the second run we have chosen the discounted sum of the increments of the forest sector to gross national product as an objective function. The results have been illustrated using dotted lines in the same Figures 2 through 7.

Compared with the previous case, there is no significant difference in the production of sawn goods, panels and converted paper products for which export demand again limits the production. However, there is a significant difference in pulp and paper production. Pulp (both mechanical and chemical) is now produced to satisfy fully the demand for export. Paper production is now steadily increasing from 5 million ton/year to nearly 9 million ton/year. Paper export is still declining again due to increasing use for the converting processes of paper products. Therefore, the export demand for paper is not fully exploited.

The bottleneck for paper production now is the biological capacity of the forests to supply wood. The use of round wood increases from about 40 million  $m^3$ /year to the level of 65 million  $m^3$ /year. The increase in the yield of the forests may be explained by the change in the age structure of the forests during the planning horizon. Such change over the period 1980-2010 has been illustrated in Figure 8.

We notice a significant difference in the wood use between these first two runs. We may conclude that in the first run (the profit maximization) the national wood resources are being used in an inefficient way; i.e., under the assumed price and cost structure the poor profitability of the forest industry results in an investment behavior which does not make full use of the forest resources.



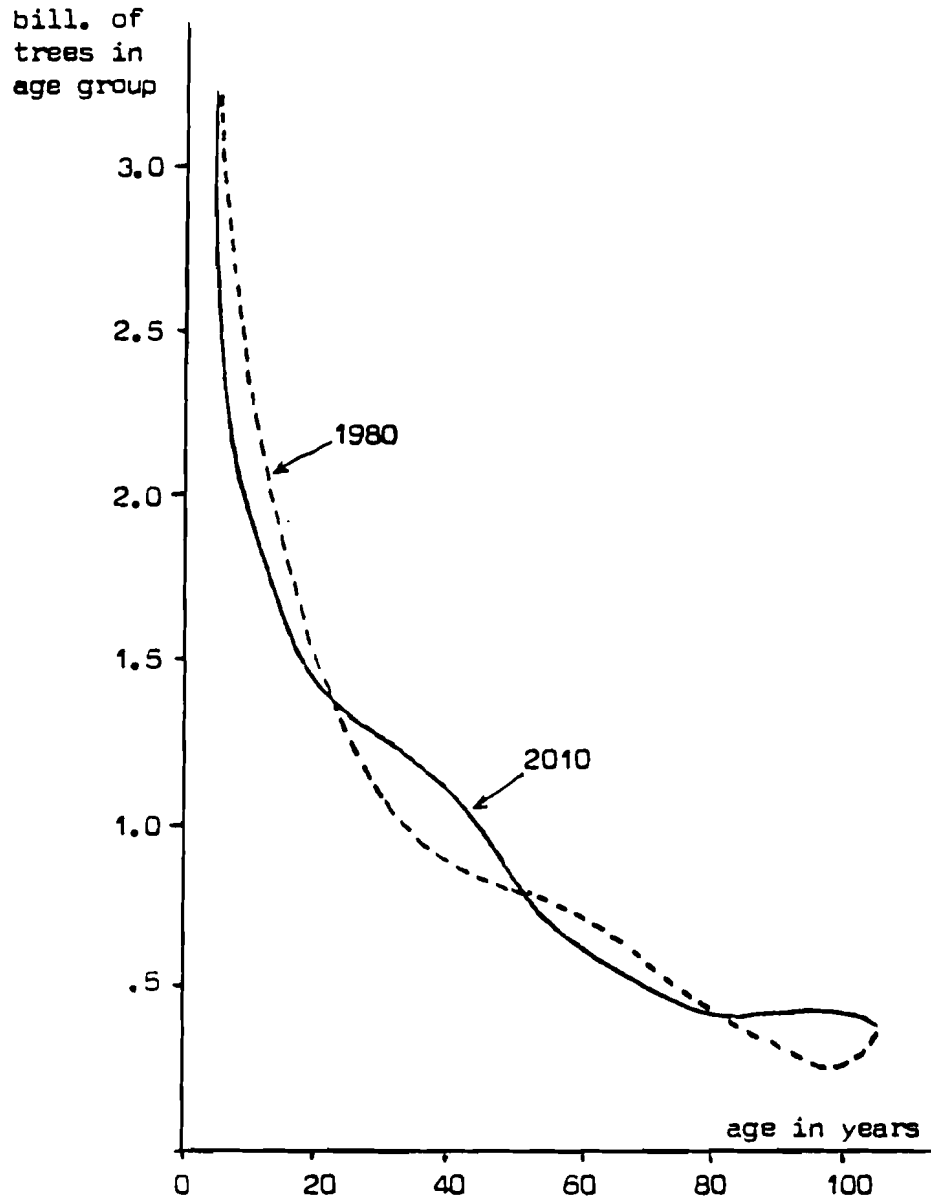

Figure 8. Age distribution of trees in 1980 and in 2010 according to Run2.

The third run is the same as the first one except that the larger version of the model was used and pulp import was allowed to be used in paper mills. The production of sawn goods and converted paper products, as described by broken lines in Figure 2, still meet the export demand. However, panel production is declining and it falls well below the level of the previous runs. The reason is that panel production is now considered as a separate financial unit which cannot afford to keep up its production capacity. Thus, an increase in panels production appears to be possible only if it is supported from other product lines. Similarly, the use of spruce for mechanical pulp appears unprofitable so that its production is declining. Production of Si-pulp (for which spruce pulpwood is used) grows steadily from 5 million ton/year to about 10 million ton/year. No spruce is used for Sa-pulp but both the use of pine and birch for Sa-pulp increase over time so that the total production of chemical pulp increases from about 3.5 million ton/year to the level of 7 million ton/year during the planning horizon. Thus chemical pulp production somewhat exceeds the amount produced in the first run.

Paper production in this third run exceeds the level obtained in both previous runs. The reason is that imported pulp is now allowed to be used in paper mills. (Note that in the second run, the raw wood supply was the limiting factor for paper production.) As a consequence, total paper production increased from 5 million ton/year to above 11 million ton/year. The share of newsprint is about one fifth and the share of printing paper one quarter. Only paperboard production appears to decline.

From the production curves of the primary uses of wood, i.e., sawn goods, panels and pulp, we may conclude (comparing with the second run) that wood resources are again being used inefficiently. It appears that, under the assumed price and cost structure, fiber (pulp in particular) import to be used as raw material in paper mills is more profitable than the use of domestic wood raw material.

## 6. SUMMARY AND POSSIBLE FURTHER RESEARCH

We have formulated a dynamic linear programming model of a forest sector. Such a model may be used for studying long-range development alternatives of forestry and forest based industries at a national and regional level. Our model comprises of two subsystems, the forestry and industrial subsystem, which are linked to each other through the raw wood supply from forestry to the industries. We may also single out static temporal submodels of forestry and industries for each interval (e.g., for each five year period) considered for the planning horizon. The dynamic model then comprises of these static submodels which are coupled with each other through inventory-type of variables; i.e., through state variables.

The forestry submodel describes the development of the volume and the age distribution of different tree species within the nation or its subregions. Among others, we account for the land available for timber production and the labor available for harvesting and planting activities. Also ecological constraints, such as preserving land as a watershed may be taken into account.

In the industrial submodel we consider various production activities, such as saw milling, panel production, pulp and paper milling, as well as further processing of primary products. For a single product, alternative production activities employing, for instance, different technologies, may be included. Thus, the production process is described by a small Leontief model with substitution. For the end product demand an exogenously given upper limit is assumed. Some products, such as pulp, may also be imported into the forest sector for further processing. Besides biological supply of wood and demand for wood based products, production is restricted through labor availability, production capacity, and financial resources. Availability of different types of labor (by region) is assumed to be given. The development of different types of production capacity depends on the initial situation in the country and on the investments which are endogeneous decisions in the model. The production

activities are grouped into financial units to which the respective production capacities belong. The investments are made within the financial resources of such units. External financing is made available to each unit up to a limit which is determined by the realization value of that unit. Income tax is assumed proportional to the net income of each financial unit.

The structure of the integrated forestry-forest industry model is given in the canonical form of dynamic linear programs for which special solution techniques may be employed. (See, for instance, Kallio and Orchard-Hays 1979, Propoi and Krivonozhko 1978). Objectives related to gross national product, employment and profit for industry as well as for forestry have been formulated. Terminal conditions (i.e., values for the state variables at the end of the planning horizon) have been proposed to be determined through an optimal solution of a stationary model for the forest sector.

Two versions of the Finnish forest sector model have been implemented for the interactive mathematical programming system called SESAME (Orchard-Hays 1978). Both versions are ten period models with each period five years in length. In neither case has the country been divided into subregions. The main difference between these versions are in the number of production activities and in the number of financial units. No distinction has been made between the tree species in the smaller version whereas pine, spruce, and birch are considered explicitly in the larger one. The complete model amounts to 520 rows and 612 columns in the smaller case, and to 2320 rows and 3188 columns for the larger model.

A few numerical runs have been presented to illustrate possible use of the model. Both the discounted industrial profit and the discounted increment to the GNP were used as objective functions. The results obtained illustrate a case where the internal wood price and wage structure results in a rather poor profitability for the forest industries. This in turn amounts to an investment behavior which provides insufficient capacity for making full use of the wood resources.

However, because of somewhat hypothetical data used for some key parameters, no conclusions based on these runs should be made on the Finnish case.

The purpose of this work has been the formulation, implementation and validation of the Finnish forest sector model. Natural continuation of this research is to use the model for studying some important aspects in the forest sector. For instance, the influence of alternative scenarios of the energy price and the world market prices for wood products would be of interest. Furthermore, the studies could concentrate on employment and wage rate questions, on labor availability restrictions and productivity, on new technology for harvesting and wood processing, on the influence of inflation and alternative taxation schemes, on land use between forestry and agriculture, on site improvement, on ecological constraints, on the use of wood as a source of energy, etc. Given the required data, such studies can be carried out relatively easily.

Further research requiring a larger modeling effort may concentrate on regional economic aspects, on linking the forest sector model for consistency to the national economic model, and on studying the inherent group decision problem for controlling the development of the forest sector. The first of these three topics requires a complete revision of our model generating program and, of course, the regionalized data. The second task may be carried out either by building in the model a simple input-output model for the whole economy where the non-forest sectors are aggregated up to ten sectors. Alternatively, our current model may be linked for consistency to an existing national economic model. The group decision problem has been proposed to be analyzed, for instance, using a multicriteria optimization approach (Kallio, Lewandowski, and Orchard-Hays forthcoming) which is based on the use of reference point optimization (Wierzbicki 1979).

APPENDIX: NOTATION

Indices

a, a'	age group of trees (range 1, ..., N)
d	type of forest land
g	type of resource for forestry activities
h	harvesting activity
i	production activity (of the forest industries)
j	industrial product
k	timber assortment
n	planting activity
s	tree species
t	time period (range 1, ..., T)

State and control variables

b(t)	stockholders equity at the beginning of period t
$b^0 = b(0)$	initial level of stockholders equity
c(t)	cash (and receivables) at the beginning of period t
$c^0 = c(0)$	initial amount of cash
$c^*$	terminal requirement for cash
$e(t) = \{e_j(t)\}$	export (and sales outside the forest sector) of forest products during period t

$l(t)$	beginning balance of external financing for period $t$
$l^0 = l(0)$	initial balance of external financing
$l^*$	terminal requirement for external financing
$l^+(t)$	drawings of debt during period $t$
$l^-(t)$	repayments made during period $t$
$m(t) = \{m_j(t)\}$	import of forest products during period $t$
$p^+(t)$	profits of period $t$
$p^-(t)$	(financial) losses of period $t$
$q(t)$	production capacity at the beginning of period $t$
$q^0 = q(0)$	initial level of production capacity
$q^*$	terminal requirement for production capacity
$\bar{q}(t)$	fixed assets at the beginning of period $t$
$\bar{q}^0 = \bar{q}(0)$	initial value of fixed assets
$\bar{q}^*$	terminal requirement for fixed assets
$r(t) = \{r_k(t)\}$	timber assortments inventory at the beginning of period $t$
$r^0 = r(0)$	initial level of timber assortments inventory
$r^*$	terminal requirement for timber assortments inventory
$u^-(t) = \{u_h^-(t)\}$	level of harvesting activities during period $t$
$u^-$	level of harvesting in a stationary solution
$u^+(t) = \{u_n^+(t)\}$	level of planting activities during period $t$
$u^+$	level of planting in a stationary solution
$v(t)$	level of investments (in physical units) during $t$
$w(t) = \{w_s(t)\} = \{w_{sa}(t)\}$	number of trees at the beginning of period $t$
$w^0 = w(0)$	initial number of trees
$w^*$	terminal requirement for the number of trees
$w$	number of trees in a stationary solution

$x(t)$	level of production activities during period $t$
$X(t)$	state vector at the beginning of period $t$
$x^0 = x(0)$	initial state
$x^*$	requirement for terminal state
$y(t) = \{y_k(t)\}$	supply of timber assortments during period $t$
$Y(t)$	level of control activities during period $t$
$z^+(t)$	import of timber assortments during period $t$
$z^-(t)$	export of timber assortments during period $t$

### Parameters

$\alpha_{aa'}^s(t)$	ratio of trees of species $s$ and in age group $a$ that will proceed to age group $a'$ during period $t$
$\alpha, \alpha^s$	matrices of coefficients $\alpha_{aa'}^s(t)$
$\beta(t)$	discounting factor
$\gamma(t)$	objective function coefficients for the state vector $X(t)$
$\Gamma(t)$	coefficient matrix for the state vector $X(t)$ in the state equation
$\delta$	physical depreciation rates
$\bar{\delta}(t)$	financial depreciation rates
$\Delta$	age interval in an age group of trees (e.g., five years)
$\varepsilon(t)$	interest rates for external financing
$\psi(t)$	right hand side vector of constraints for period $t$
$\phi(t)$	coefficient matrix for the state vector $X(t)$ in constraints for period $t$
$\eta$	matrix relating planting activities to the increase in the number of trees
$\lambda(t)$	objective function coefficients for the control vector $Y(t)$
$\Lambda(t)$	coefficient matrix for the control vector $Y(t)$ in the state equation
$\omega$	matrix relating harvesting activities to the decrease in the number of trees
$\Omega(t)$	coefficient matrix for the control vector $Y(t)$ in constraints for period $t$
$\rho(t)$	labor requirement for different production activities
$\tau(t)$	tax factors for the industries during period $t$



$\mu(t)$	upper limit to external financing as a percentage of total assets less short term liabilities
$\xi(t)$	right hand side vector for the state equation of period $t$
$A(t)$	input-output matrix for the forest industries
$B(t)$	stock issued during period $t$
$C(t)$	direct unit production costs
$D(t)$	exogeneously given costs
$E(t)$	upper bound on demand of forest products
$F(t)$	fixed costs (per unit of production capacity)
$G = (G_{ad}^S)$	land requirement of the species in various age groups
$H(t)$	land available for forests
$I$	identity matrix
$J^-(t)$	objective function coefficients for harvesting activities (an example)
$J^+(t)$	objective function coefficients for planting activities (an example)
$K(t)$	investment costs per capacity unit
$L(t)$	labor available for forest industries
$M(t)$	upper limit on import of forest products
$N$	number of age groups for trees
$P(t)$	prices of forest products
$Q(t)$	matrix of capacity requirements for production activities
$R(t) = \{R_g(t)\}$	resources available for forestry activities
$R^+(t) = \{R_{gn}^+(t)\}$	resource usage of planting activities
$R^-(t) = \{R_{gh}^-(t)\}$	resource usage of harvesting activities
$S(t)$	matrix transforming the trees harvested into volumes of timber assortments
$T$	number of time periods
$U$	usage of timber assortments by various production activities

REFERENCES

- Barros, O., and A. Weintraub (1979) Planning for Vertically Integrated Forest Industry. Presented at Tenth International Symposium on Mathematical Programming, Montreal.
- Dantzig, G. (1963) Linear Programming and Extensions. Princeton, N.J.: Princeton Univ. Press.
- Dantzig, G. (1974) Determining Optimal Policies for Ecosystems. Technical Report 74-11. Stanford, California: Department of Operations Research, Stanford University.
- Jackson, B. (1974) Forest Products in the United Kingdom Economy. Ph.D. thesis, Department of Forestry, Oxford University.
- Jegr, K., E. Miller, and K. Thompson (1978) PAPERISIM 1 - A Dynamic Model of the Canadian Pulp and Paper Industry. Pointe Clair, P.Q.: Pulp and Paper Research Institute of Canada.
- Kallio, M., W. Orchard-Hays, and A. Propoi (1979) Linking of Optimization Models. WP-79-83. Laxenburg, Austria: International Institute for Applied Systems Analysis.
- Kallio, M., and W. Orchard-Hays (1979) Experiments with the Reduced Gradient Method for Linear Programming. WP-79-84. Laxenburg, Austria: International Institute for Applied Systems Analysis.
- Kallio, M., A. Lewandowski, and W. Orchard-Hays (1980) Application of a Multicriteria Optimization Method Using Reference Objectives. Laxenburg, Austria: International Institute for Applied Systems Analysis. Forthcoming.

- Kilikki, P., K. Kuusela, and M. Siitonen (1977) Timber production programs for the forestry board districts of southern Finland. *Folia Forestalia* 307, The Finnish Research Institute (in Finnish).
- Newnham, R. (1975) LOGPLAN, A Model for Planning Logging Operations. Information Report FMR-77. Ottawa: Forest Management Institute, Canadian Forestry Service.
- Navon, Daniel I. (1971) Timber RAM--A Long Range Planning Method for Commercial Timberlands Under Multiple-Use Management. USDA Forest Service Research Paper PSW-70. Berkeley, California: Pacific Southwest Forest and Range Experiment Station.
- Näslund, B. (1969) Optimal rotation and thinning. *Forest Service* 15.
- Orchard-Hays, W. (1978) Anatomy of a mathematical programming system. Design and Implementation of Optimization Software, edited by H. Greenberg. Netherlands: Sijthoff and Noordhoff.
- Propoi, A., and V. Krivonozhko (1978) The Simplex Method for Dynamic Linear Programs. RR-78-14. Laxenburg, Austria: International Institute for Applied Systems Analysis.
- Randers, J. (1976) A System Dynamic Study of the Transition From Ample to Scarce Wood Resources. Hanover, N.H.: Publications of Resource Policy Center, Dartmouth College.
- Rorres, C. (1978) A linear programming approach to the optimal sustainable harvesting of a forest. *Journal of Environmental Management* 6.
- Seppälä, H., J. Kuuluvainen, and R. Seppälä. The Finnish Forest Sector at the Turning Point (in Finnish). Forthcoming.
- Steuer, R. and A. Schuler (1978) An interactive multiple-objective linear programming approach to a problem in forest management. *Operations Research* 26.
- Wardle, P. (1965) Forest management and operational research: a linear programming study. *Management Science* 11.
- Ware, G., and J. Clutter (1977) A mathematical programming system for the management of industrial forests. *Forest Science*, 17.
- Weintraub, A., and D. Navon (1976) A forest management planning model integrating silvicultural and transportation activities. *Management Science* 22.
- Wierzbicki, A. (1979) A Methodological Guide to Multiobjective Optimization. WP-79-122. Laxenburg, Austria: International Institute for Applied Systems Analysis.

Williams, D. (1976) Integrating Stand and Forest Models for Decision Analysis. Ph.D. thesis, Department of Forestry, University of British Columbia.

Yearbook of Forest Statistics 1977/1978. Official Statistics of Finland XVII A:10, The Finnish Forest Research Institute.

STRUCTURAL CHANGE IN THE FOREST INDUSTRY:

A FRAMEWORK OF MODELS

Börje Johansson

STRUCTURAL CHANGE IN THE FOREST INDUSTRY: A FRAMEWORK OF MODELS<sup>\*)</sup>

Börje Johansson  
Department of Economics  
University of Gothenburg

1. INTRODUCTION

In a county like Sweden the forest industry constitutes a sector which is extremely oriented towards the world market. At the same time this industry is characterized by a set of basic rigidities. Firstly, the supply of inputs from the forestry sector is determined by a slow growth process in regionally concentrated areas. Secondly, the paper and pulp sector, here called "paper and paper products industry", is characterized by a high capital coefficient and the capital equipment has, in a historical perspective, shown an extraordinary long durability. Thirdly, different sectors of the forest industry are highly concentrated to a distinct set of separated regions.

In this paper a set of models are suggested as a fundamental basis for medium and long-term analysis of the forest industry. An introductory and detailed presentation is given of a vintage model. Moreover, the paper outlines different ways to connect this model with dynamic input-output models, programming models, capital formation analysis and scenario-oriented forecasts. The ambition of the paper is to provide an overview of certain models which are planned to be utilized in a research project, focusing on the forest industry from a regional and interregional perspective.

---

<sup>\*)</sup> This paper summarizes a presentation given at IIASA in January 1980. Several of the ideas in the paper have sprung from discussions with Å. Andersson, U. Strömquist and H. Persson.

## 2 A FRAMEWORK FOR ANALYZING STRUCTURAL CHANGES IN THE FOREST INDUSTRY

The expansion of the forest industry in Sweden had its take off phase in the second half of the nineteenth century. A low price on the raw material supplied by the forest sector stimulated the growth of the manufacture of paper and paper products. During a period of about 100 years the production technique developed relatively slowly, smoothly following the expansion of the market. The growth of forest industry production relied on the availability of cheap raw materials. However, in the long-run the process could not avoid "the Ricardian law", with the result that harvesting now has been pushed farther and farther into less favourable forest areas.

The growth of the demand for paper and pulp between 1860-1960 made it possible for the industry to gradually combine the introduction of new production techniques with a capacity expansion. This may be regarded as a basic feature of a very long non-dramatic period of growth. At the end of the 1950s, the forest industry of Sweden ran into a situation of excess demand for raw materials which brought about structural changes in the competition conditions of the forest industry in Sweden as well as in the other Nordic countries.

### *2.1 Recent Development Patterns in the Swedish Forest Industry*

Together with iron and steel production the forest industry forms "the traditional exportation sectors" of the Swedish industry. During the 1950s more than half of the total value of exports emerged from these sectors. During the mid-seventies this figure had declined to about one fourth. This decline was the result of a long-term change of the composition of the Swedish industry. The change of the relative position of the traditional export-sectors is contrasted by the fact that the proportion of total industry investments going to these sectors has continued to be high throughout the Sixties and Seventies.

It has been suggested that a series of prosperous years for the forest industry during the Fifties and the early Sixties gave rise to an investment activity which continued in spite of a discouraging develop-

ment of the relation between demand and the capacity of the forestry sector. The investment pattern is illustrated in Table 1, which provides a ranking of countries with investment priorities.

Table 1 The proportion of total industry investment going to sectors of forest industry, 1965-1975. Percentage

---

	Wood and wood products	Paper and paper products	Total
Finland	8	23	31
Sweden	8	17	25
Canada	7	15	22
Norway	7	8	15
Austria	6	6	12
USA	3	6	9

---

On the basis of a thorough classification (comparison) of the industry sectors in Sweden with regard to the vintage structure and profitability of each sector one may characterize the forest industry sectors during the period between 1965-1977 in the following way:

- The paper and paper product sector, which includes the pulp industry, has held a medium profitability position with a mixed vintage structure. The sector has had a large proportion of its total employment in establishments in which the gross profit has been too small to cover fixed costs; for a large number of these establishments the gross profit has, on an average, even been negative during the period.
- The wood and wood product sector has had a more favourable development. However, this sector has also had a rather large proportion of its employment in establishments with low or negative gross profits. But as opposed to the paper and paper product sector, this sector has, on an average, had a high profit level.



During the period between 1975-1977 the vintage structure, or in other words, the obsolescence pattern of the Swedish forest industry changed unfavourably. Only a small part of this change can be explained by the general economic recession during these years. The number of persons employed in obsolete parts of the forest industry increased to a level corresponding to around 15-20 per cent of total employment in the forest industry. Although this change occurred in both of the forest industry sectors considered here, the wood and wood products sector succeeded nevertheless to retain a significant share of its establishments in a high profit position. The paper and paper products sector was less fortunate in this respect; here only a small part of total employment was allocated to competitive establishments at the end of the period.

A significant feature of the forest industry is that its present problems are concentrated to certain specific regions which makes the structural change process not only an industrial policy concern, but even more of a regional policy problem. The methods and system of models suggested in the subsequent sections are designed to incorporate regional characteristics and dependencies of the forest industry. The system of models is also designed to capture the importance of transportation costs, world market prices, energy and harvesting costs during the next two decades.

## *2.2 A system of models for the analysis of the forest industry*

In this section we shall introduce a set of conditions which a medium and long term analysis of the forest industry should fulfil. We shall also suggest a system of models which satisfies these conditions; this system consists of three groups of models, describing domestic multi-sectoral growth, world trade, and domestic structural change.

An industry sector is an interconnected part of a multisector system. This means that a model of structural change and growth of a sector must be related to a multisector growth model. When the latter type of model is used as a basic framework, each single sector can be forecasted and analyzed as part of a consistent multisector scenario which also constitutes a reference system for the analysis of structural change within a sector.

Domestic multisector growth models of standard input-output type depict economic systems in which price and wage levels are system-wide. In a closed model these prices are obtained endogeneously as a solution to the model; they will therefore represent domestic prices. In an open model the domestic price formation must be tied to international price movements. This type of approach is particularly relevant for the forest industry which, today, is of a highly international nature. This implies two things: The price formation takes place on the world market, and transportation costs play a significant role in that price formation process.

In order to capture medium and long-run market reactions to the supply and demand from different countries it is necessary to construct and make use of a world market trade model. Such a model must be able to produce consistent trade scenarios. To examine trade consistency one must build a multisector trade model in which trade patterns are described by a matrix that classifies trade flows in two dimensions: Delivering sector (type of product) and Delivering country (groups of countries).

A domestic multisector input-output model illustrates the average sector relations and average input requirements for each sector. Changes occurring in the input-output table over time are usually brought into the model exogenously by means of some supplementary model, often in the form of a statistically determined trend equation.

We shall suggest a model system which focuses on the differences between establishments in each sector. Each establishment is given a sector-specific vintage classification depicting productivity, profitability and input requirements of the establishment. In the following sections the outline of such a model system is sketched. The models in this system are called 'structural change models'. These models are designed to use price and quantity information from a world trade model as input. A domestic structural change model may use a combination of world trade information and information from a domestic input-output model. With this type of information input, the models are required to trace the expected domestic consequences in terms of structural

change. Such changes may include investment in existing establishments, exit and entry of establishments, and product development. These types of processes also imply alterations of profit level, productivity and input requirements.

The estimation of the effects of the structural change process may be regarded as the final step in a structural analysis. These structural effects may, in addition, be used to determine the gradual changes in domestic input-output coefficients. In medium term forecasting one may even have a closed-loop linkage between a dynamic input-output and a structural change model.

The flow of information between the three sets of models discussed is described in Figure 1. The information flows are shown to emphasize the possibilities of making consistency tests and of forming converging iteration loops.

Figure 1 A system of models for medium and long term analysis

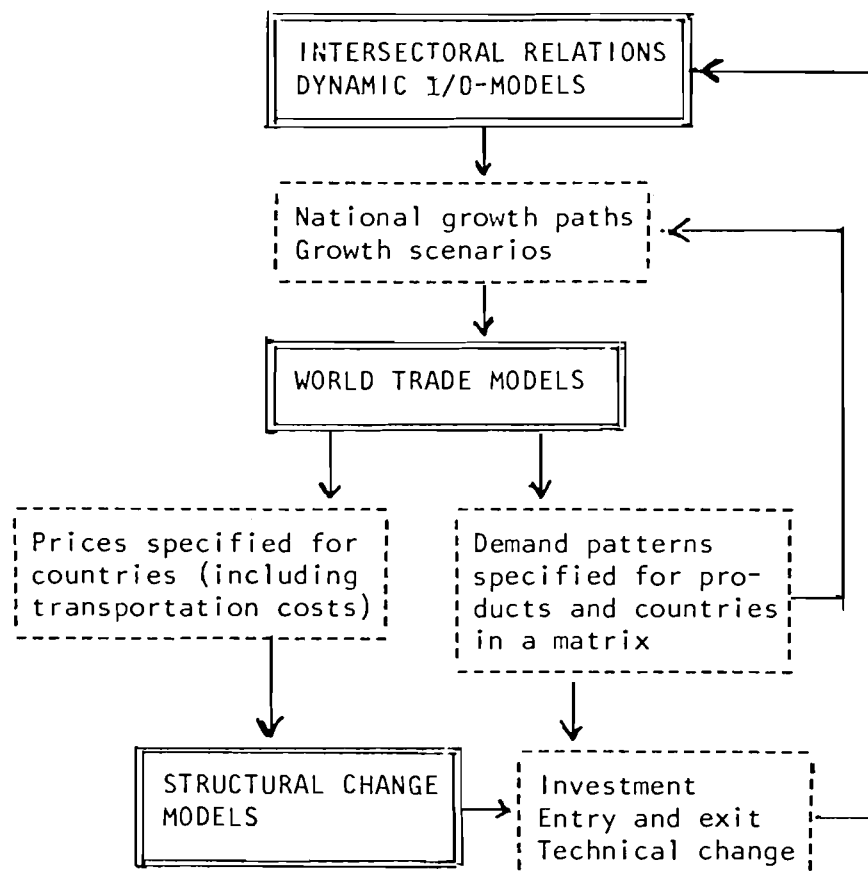

### 3 A VINTAGE MODEL FOR STRUCTURAL ANALYSIS OF THE FOREST INDUSTRY

A basic feature of the approach to structural analysis developed in this paper is a regional specification of each industry sector and of the forestry sector. In addition, the model system is required to satisfy the following conditions:

- Aggregation from the regional level must be consistent with the national multisector model.
- The model system must focus on existing rigidities in the adaption process of the production systems of each sector.
- It must be possible to estimate and run the models with no other data input than industrial statistics produced annually in Sweden.

To fulfil these requirements we shall utilize a vintage model formulation which has strong connections with putty-clay models in which the basic distinction is that between ex ante and ex post. This type of models stresses the existence of significant substitution possibilities ex ante, before the installation of capital in the establishment; it also stresses the property that ex post, after the concrete design of the installed capital equipment, factor proportions and input requirements are rigid with a narrow range of feasible variations.<sup>1)</sup> A vintage model suggested here relies heavily on putty-clay production theory, but it is intended (developed) to focus on regional characteristics and to allow stochastic formulations which depict ageing and renewal processes and which make it possible to interpret model results by means of statistical theory.

#### 3.1 *Distribution of Establishments over the Input Space, and Production rigidities*

Consider an establishment with a given organisation and capital equipment. For this establishment there exists production rigidities. We shall assume that these rigidities can be represented by the following assumption of putty-clay type:

---

1) Among others, we may here refer to Johansen, L (1959), (1972), Salter, WFG (1960), Phelps (1962), (1963), Solow, RM (1967).

- (a.1) There exists for the establishment a capacity limit  $\bar{x}$ , such that the output,  $x$ , satisfies  $0 \leq x \leq \bar{x}$ .

There exist  $n_a$  input coefficients  $a_1, \dots, a_{n_a}$ , such that the necessary input of resource  $j$  is determined by the equation  $v_j = a_j x$ , where  $v_j$  denotes the consumption of resource  $j$ , e.g., raw materials, energy, and other variable input.

There exist  $n_s$  labour input coefficients  $s_1, \dots, s_{n_s}$  such that the necessary input of labour of type  $j$  is determined by the equation  $S_j = s_j x$ , where  $S_j$  denotes the number of persons occupied with task  $j$ .<sup>1)</sup>

Let  $(q_1, \dots, q_{n_a})$  be the price vector associated with the vector  $(a_1, \dots, a_{n_a})$  and let  $(w_1, \dots, w_{n_s})$  be the vector of wage levels associated with  $(s_1, \dots, s_{n_s})$ . In the subsequent analysis we shall use a price index  $q$  and an input coefficient  $a_v$  such that

$$(2) \quad \sum q_i a_i = q a_v ; v = a_v x$$

where  $v$  denotes the aggregate input of variable resources.

We shall also use a wage index  $w$  and a labour input index  $a_s$  such that

$$(3) \quad \sum w_i s_i = w a_s ; S = a_s x$$

where  $S$  denotes the total number of persons employed.

Aggregation of the type described in (2) - (3) generally involves more or less accurate approximations.<sup>1)</sup> With the aggregate input coefficients  $a_v$  and  $a_s$  we shall construct a two-dimensional input space, consisting of all non-negative pairs  $(a_v, a_s)$  as described in Figure 2. In Figure 2 each establishment  $j$  is represented by a triple  $(\bar{x}^j, a_v^j, a_s^j)$  describing the capacity and input coefficients of establishment  $j$ . The shaded area depicts the domain of the  $(a_v, a_s)$  - space in which the production capacity is positive.

---

1) One should observe that in certain applications labour input may, contrary to the assumption, be modelled as completely rigid in the short run so that  $S_j(t) = S_j(t-1)$ .

Figure 2 Illustration of the distribution of capacities in the input space

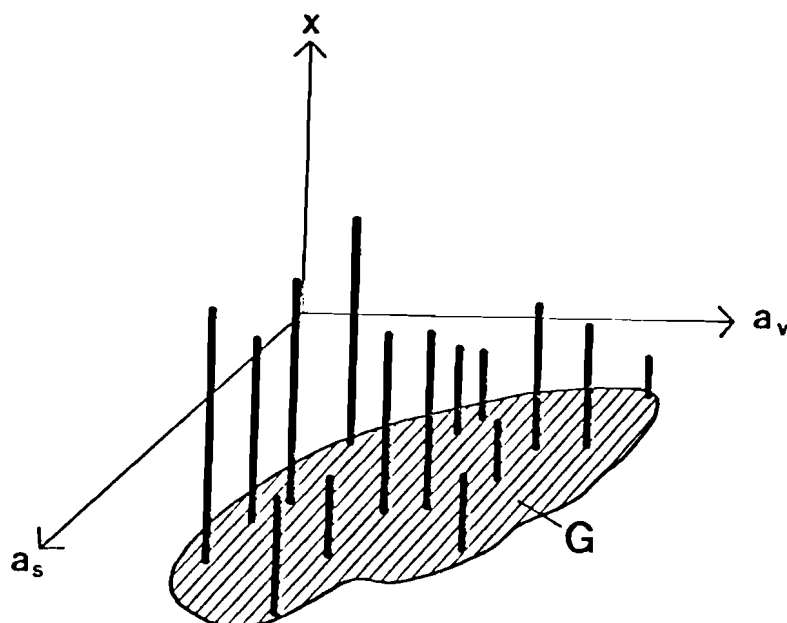

The existing capacity rigidities of an establishment are in (2)-(3) represented by the fixed  $a_v$  and  $a_s$  coefficients. However, reinvestments may change the coefficients. Therefore, we have to observe that these coefficients should be modelled as fixed for each given year  $t$ ; this is emphasized by using the notation  $a_v(t)$  and  $a_s(t)$ . With this extension of the model, the rigidities must now be related to the fact that economic incentives for reinvestments will develop in a step-wise, non-continuous way. This argument will be extended in the subsequent sections. As a step in that direction the following price determined variables are introduced:

$$(4) \quad Q(t) = p(t) x(t), \text{ where } p(t) \text{ denotes the output price and } x(t) \text{ the output year } t; Q(t) \text{ denotes the value of sales.}$$

$$V(t) = q(t) a_v(t) x(t) = q(t) v(t), \text{ where } q(t) \text{ denotes the input price at year } t; V(t) \text{ denotes input costs}$$

$$F(t) = Q(t) - V(t); F(t) \text{ denotes value added}$$

$$W(t) = w(t) a_s(t) x(t) = w(t) S(t), \text{ where } w(t) \text{ denotes the wage level year } t; W(t) \text{ denotes the wage sum.}$$

$B(t) = F(t) - W(t)$  ;  $B(t)$  denotes gross profits.

$b(t) = B(t)/F(t)$  ;  $b(t)$  denotes gross profit share

Assuming that establishments and their production capacities are continuously distributed over the input space, we may use the variables in (4) to obtain the price determined version of Figure 2 in Figure 3. In the latter we illustrate the distribution of value added,  $F(a_v, a_s)$ , over the input space. The marginal distributions  $F(a_s)$ ,  $F(a_v)$ ,  $B(a_s)$  and  $B(a_v)$  are also shown.

### 3.2. *The vintage model assumption*

One of the most important features of the vintage approach is the distinction between the technical or physical lifetime and the economic lifetime of the production system in an establishment. This is a distinction between physical depreciation and economic obsolescence. Increasing obsolescence may empirically be observed as a successively decreasing stream of quasi-rents, here called gross profits and denoted by  $B(t)$ . This process reflects the economic ageing of an establishment; it may continue until gross profits no longer cover any part prime costs, i.e. until gross profits becomes zero or even negative.

During a certain time-span new plants are being constructed and some of the existing plants may be renewed as a result of reinvestments. The growth of technological knowledge implies that gradually newer and more efficient plants are introduced. With regard to the forest industry sectors one should also recognize the gradual opening of new areas for harvesting. The competition from new establishments and new harvesting areas are two important factors which cause the decline of gross profits in establishments which are growing old.

Our observation unit is an establishment, and this unit is analyzed as an organisation which consists of subsystems. The capital equipment (durable resources) in different systems will generally have different dates of construction. The durable resources may also be replaced through reinvestments at different dates, in different subsystems.

Figure 3 Value added and gross profits distributed over the input coefficients

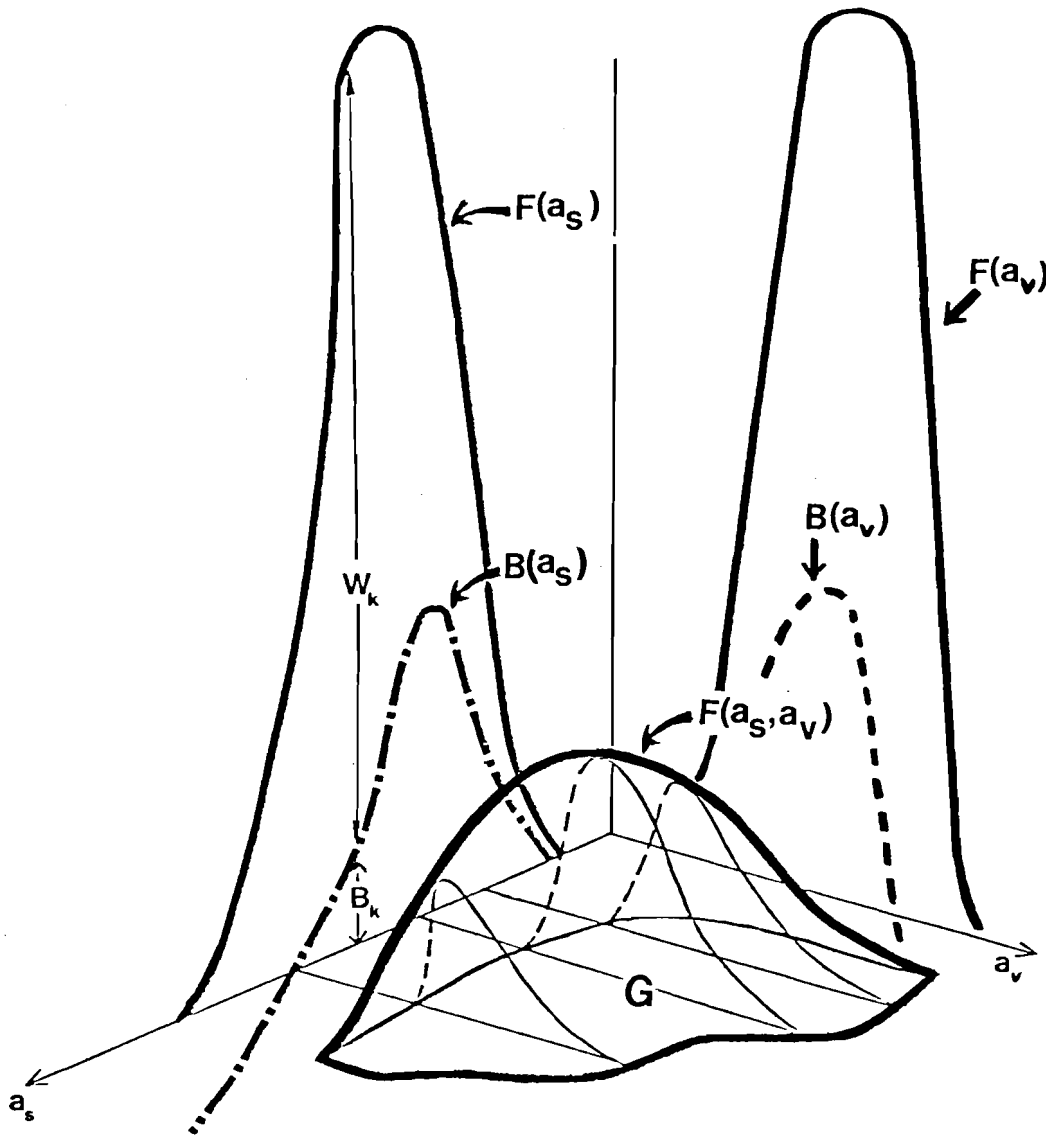

- $F(a_s, a_v)$  = Distribution of value added on the input space
- $F(a_s)$  = Distribution of value added on the labour input space
- $F(a_v)$  = Distribution of value added on  $a_v$ -input space
- $B(a_s)$  = Distribution of gross profits on the labour input space
- $B(a_v)$  = Distribution of gross profits on the  $a_v$ -input space



When one or several subsystems are renewed, the aggregate input coefficients  $a_v$  and  $a_s$  may change. Such a change is assumed to raise the profit share of the establishment.

We shall consider a set  $M$  of vintage indexes  $\tau$ , such that

- (5)  $M = \{\tau: \tau=1, \dots, n\}$ , and such that increasing values of  $\tau$  indicate increasing economic age (obsolescence).

Consider next the set  $E = \{b: \{1 \geq b > -\infty\}$  and let  $\xi_\tau \subset E$ , such that

- (6)  $\xi_\tau = \{b: (1, 1 - 0, 1\tau) \geq b > (1 - 0, 1\tau)\}$   
for all  $\tau \in M$

With this construction we shall introduce a mapping  $T: E \rightarrow M$  such that

- (7)  $T(b) = \tau$  if  $b \in \xi_\tau$ .

In order to arrive at a precise interpretation of the concept of vintage indexes we shall first study the following equation:

$$(8) \quad b(t) = 1 - w(t)a_s(t)/(p(t) - q(t)a_v(t))$$

which shows that when the wage rate and the prices fluctuate, the gross profit share,  $b(t)$ , will also fluctuate. This implies, in turn, that the vintage index value of an establishment will fluctuate. Moreover, investments in an establishment will generally reduce the value of  $a_s(t)$  and  $a_v(t)$ , and such changes will increase the value of  $b(t)$ . Finally, for new establishments and for establishments which receive new capital equipment, learning effects may imply a successive reduction of input coefficients over a sequence of years. Assume that for each group of establishments with the same vintage index investments, market fluctuations and capacity variations occur and affect the individual production unit in a perceivably random fashion. Then it is possible to regard the index value  $\tau(t)$  of an establishment at a sequence of years as the outcome of a stochastic process. In line with this argument we shall introduce the following assumption:

(a.2) For each industry sector we assume that the transition of establishments from vintage index  $i$  to index  $j$  can be described by a probability number  $0 \leq h_{ij}(t) \leq 1$ , such that  $h_{ij}(t)$  assigns to establishments with index  $i \in M$  in year  $t-1$  a probability of receiving index  $j \in M$  in year  $t$ .

The vintage classification as described in (5) - (7) might be regarded as meaningful, if the probability of having a constant vintage index,  $\tau$ , is higher the lower the index value is. Table 2 illustrates that in this sense, it is meaningful to consider a vintage index even for the manufacturing industry as a whole.

Table 1 Structural constancy of b-values in the Swedish manufacturing industry 1968-1967

Index value $\tau$	b-value in an establishment year $t$	Proportion of establishments which change one index class or less between year $t$ and $t+1$	Proportion of value added in establishments which change one index class or less between year $t$ and $t+1$
1	$b \geq 0,9$	94	98
2	$0,9 > b \geq 0,8$	76	90
3	$0,8 > b \geq 0,7$	70	88
4	$0,7 > b \geq 0,6$	70	82
5	$0,6 > b \geq 0,5$	70	84
6	$0,5 > b \geq 0,4$	71	80
7	$0,4 > b \geq 0,3$	71	80
8	$0,3 > b \geq 0,2$	69	75
9	$0,2 > b \geq 0,1$	63	67
10	$0,1 > b \geq 0,0$	51	45
11	$0,0 > b \geq -0,1$	43	43
12	$-0,1 > b \geq -0,2$	52	43
13	$-0,2 > b$	55	33

### 3.3 Gross profits and capital costs

The gross profit,  $B(t)$ , of an establishment shall cover fixed costs of different types. From this point of view  $B(t)$  may be specified in the following way:

$$(9) \quad B(t) = C_1(t) + C_2(t) + C_3(t) + N(t)$$

$C_1(t)$  = fixed overhead costs

$C_2(t)$  = repair and maintenance costs

$C_3(t)$  = capital depreciation costs

$N(t)$  = net profit

We shall also introduce a variable,  $B^O(t)$ , called gross pay-off, which is defined algebraically in the following way:

$$(10) \quad B^O(t) = B(t) - (C_1(t) + C_2(t))$$

In table 3 the average values of the cost components in (9) are illustrated for two main subsectors of the forest industry.

Table 3 Fixed cost components in two subsectors of the Swedish forest industry. mean values in per cent of value added for the period 1969-1977.

	Wood and wood products %	Paper and paper products %
$B/F = b$	40	52
$C_1/F$	7	10
$C_2/F$	3	4
$C_3/F$	7	17
$N/F$	20	17
$B^O/F = b^O$	30	38

On the basis of (9) and (10) we may calculate two profitability rates in the following way:

$$(11) \quad \delta^0(t) = B^0(t)/K(t), \text{ where } K(t) \text{ denotes the value of fixed, real capital, and where } \delta^0(t) \text{ denotes the pay-off rate,}$$

$$\delta^*(t) = N(t)/K(t), \text{ where } \delta^*(t) \text{ denotes the net profitability rate.}$$

Table 4 Pay-off rate and net profitability.<sup>1)</sup>  
Average values 1969-1977

	$\delta^0$	$\delta^*$	$K(t)/F(t)$
Paper and paper products	5,6	2,5	6,8
Wood and wood products	21,4	14,3	1,4

The results in Table 3 and 4 represent mean values. In order to get a picture of the industry structure we have to consider the distribution of establishments, value added and employment over a scale of profit shares. In the subsequent sections we shall introduce analytical instruments for a description of the distributions and the analysis of structural change.

### 3.4 *Quasi-supply Functions*

In this section we shall introduce quasi-supply curves of the Salter-type.<sup>2)</sup> Such a curve describes how, for a sector, the labour cost (wage sum) in per cent of value added is increasing as marginal groups of establishments are added to the sector, starting with the establishments that have largest gross profit shares (small wage shares) and moving to establishments with gradually decreasing profit shares. With this construction we obtain a marginal cost curve which may be interpreted as a quasi-supply curve.

---

1) Capital values are estimated by the Central Bureau of Statistics (SCB)

2) Salter, W E G (1960).

Figure 4 describes the quasi-supply curve of the paper and paper product industry in Mid-Sweden. A curve which is constructed in this way has a specific merit: It is standardized in such a way that the vintage structure in different regions may be compared unambiguously. This is illustrated by Figure 5.

Figure 4 Quasi-supply curve of the paper and paper products industry in Mid-Sweden 1974

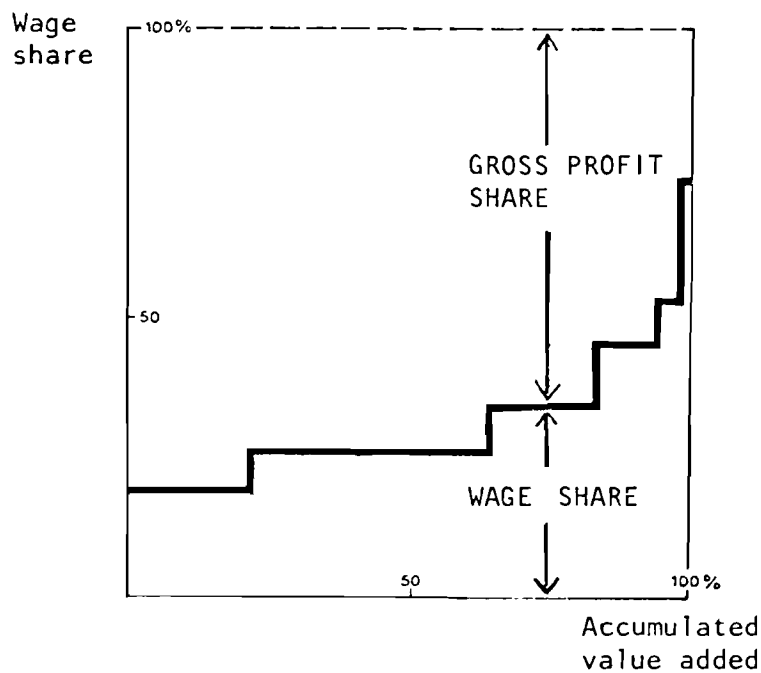
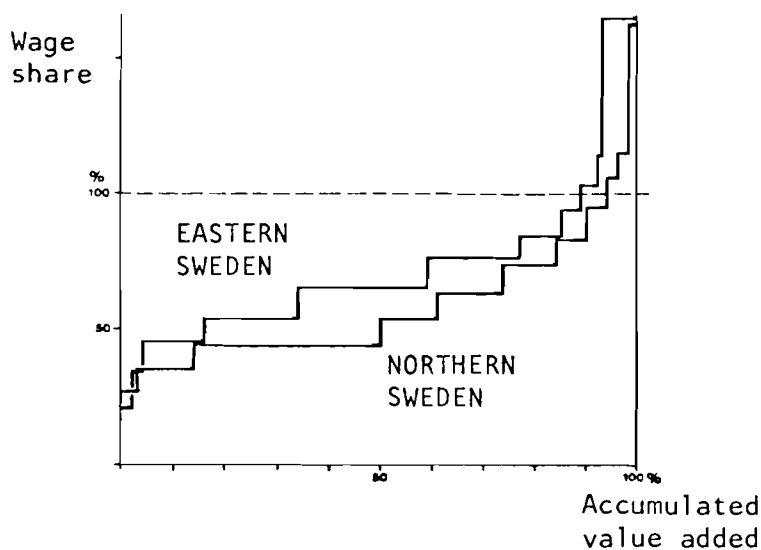

Figure 5 Quasi-supply curves of the wood and wood products industry in two regions 1977



In order to derive the quasi-supply function                      braically we shall utilize the set  $E$  and its subsets  $\xi_\tau$  defined in (6). For each set  $\xi_\tau$  we construct the set  $a(\xi_\tau)$  of input coefficients, such that

$$(12) \quad a(\xi_\tau) = \{(a_v, a_s) : b(a_v, a_s) \in \xi_\tau\}, \quad \tau \in M$$

$$b(a_v, a_s) = (p - q a_v - w a_s) / p - q a_v$$

For each set  $a(\xi_\tau)$  one may calculate the corresponding value added  $F_\tau$  in the following way:

$$(13) \quad F_\tau = \sum_{j \in J_\tau} (p - q a_v^j) g^j,$$

$J_\tau =$  index set which enumerates all establishments, such that their input coefficients belong to  $a(\xi_\tau)$ ,

$g^j =$  the capacity utilization in establishment  $j \in J_\tau, \tau \in M.$

We also need the average gross profit share,  $b_\tau$ , of establishments in the index set  $J_\tau$ . This value is calculated as follows:

$$(14) \quad b = B_\tau / F_\tau$$

$$B_\tau = \sum_{j \in J_\tau} (p - q a_v^j - w a_s^j) g^j$$

From (13) and (14) we may arrange the pairs  $(b_\tau, F_\tau)$  in the sequence  $\tau = 1, 2, \dots$  such that  $b_\tau > b_{\tau+1}$ . From this sequence we may finally construct a discrete quasi-supply function,  $U$ , which is non-decreasing:

$$(15) \quad U\left(\frac{\sum_{i=1}^{\tau} F_i}{\sum_{i=1}^n F_i}\right) = U(\hat{F}_\tau) = 1 - b_\tau, \quad \tau = 1, \dots, n;$$

$$\sum_{i=1}^{\tau} F_i = \hat{F}_\tau$$

(12) - (15) shows that the U-function changes as a reflection of changes of input-coefficients, prices and wages. Such changes are illustrated in Figure 6.

Figure 6 Quasi-supply curves in Mid-Sweden. Paper and paper products industry 1974 and 1977.

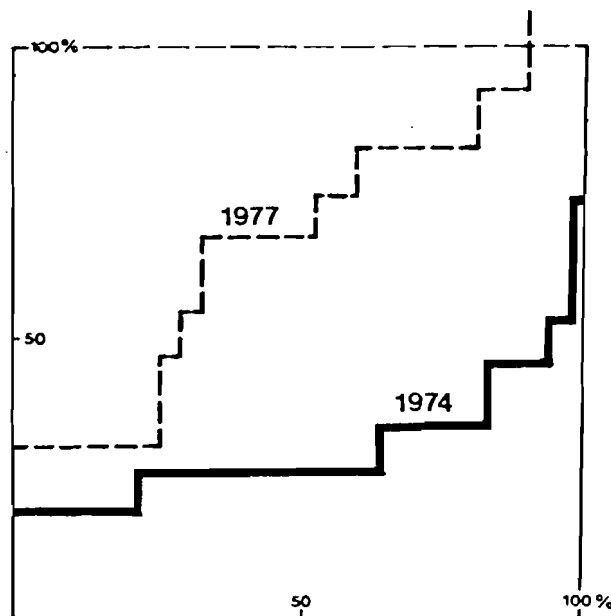

### 3.5 Quasi-demand Functions

The quasi-supply function describes how  $1 - b_\tau$  is increasing as  $U(\hat{F}_\tau)$  is increasing. A quasi-demand function may be regarded as a "dual" construction. This type of demand function shows how labour productivity in a sector is decreasing marginally as establishments are added to the sector according to the sequence  $\tau = 1, \dots, n$ .

Let  $S_\tau$  denote the number of persons employed in establishments belonging to the index set  $J_\tau$ , and let  $w_\tau$  denote the average wage level in the same set of establishments. In set  $\tau$  the labour productivity is then defined as

$$(16) \quad F_\tau/S_\tau, \quad \tau=1, \dots, n$$

The quasi-demand function,  $D$ , can according to (16) be defined as follows:

$$(17) \quad D\left(\sum_{i=1}^{\tau} S_i\right) = D(\hat{S}_\tau) = F_\tau/S_\tau, \quad \tau=1, \dots, n; \quad \sum_{i=1}^{\tau} S_i = \hat{S}_\tau$$

As long as  $F_\tau/S_\tau \geq w_\tau$ ,  $\hat{S}_\tau$  represents the number of persons who can be employed in establishments with non-negative gross profits. In this sense the function  $E$  shows the demand for labour. As  $w_\tau$  is increasing faster than  $F_\tau/S_\tau$ , the "demand"  $\hat{S}_\tau$  will gradually be reduced. If we write  $F_k/S_k = \beta_k + w$ , where  $w = w_k$  for all  $k \in M$ ,  $\beta_k$  will denote the gross profit per employed in establishments belonging to index set  $I_k$ . This is illustrated by Figure 7.

Figure 7 Quasi-demand curve describing labour productivity and gross profit per employed.

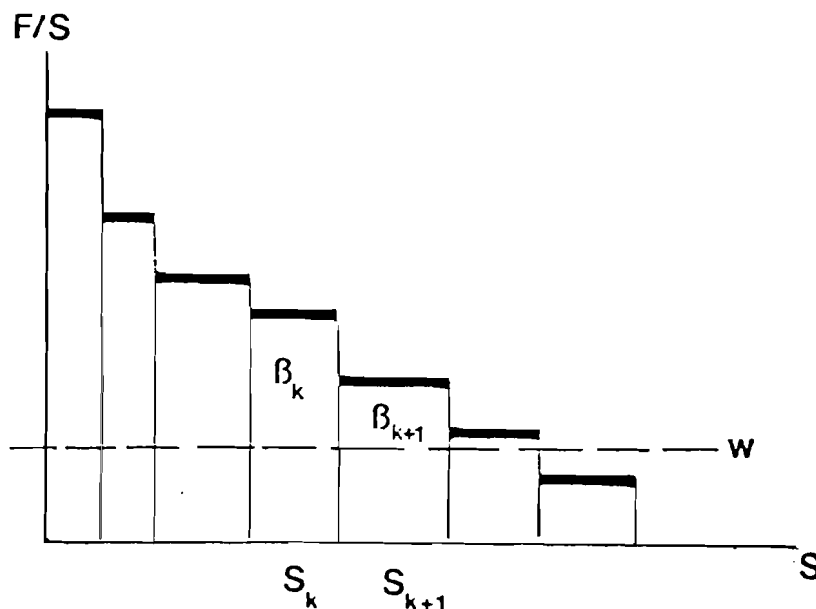



The quasi-demand function for labour can be used to describe the employment effects of alternative time-paths for the price variables  $p$ ,  $q$  and  $w$ , conditional to selected productivity changes. Since productivity changes may be related to investment policies, it is thus possible to determine national and regional policies for capital formation as a function of employment targets for different industry sectors.

Quasi-demand functions may also be estimated for different variable inputs, e.g., wood and energy. In our model setting such a curve may be constructed by forming the following sequence of ordered pairs

$$(18) \quad (\varphi^1, v^1), (\varphi^2, v^1 + v^2), \dots, (\varphi^\tau, \sum_{i=1}^{\tau} v^i), \dots;$$

$$\varphi^\tau = (p - wa_s^\tau) / a_v^\tau, \quad v^\tau = a_v^\tau x^\tau$$

The construction in (18) may easily fail to be a step-wise declining function. The quasi-demand function for labour in (17) will, however, correspond to a monotonous ranking of labour productivity if the wage level is approximately constant for all establishments. This follows from the construction in (16) which may be reformulated as

$$(19) \quad F^\tau / S^\tau = (p - qa_v^\tau) / a_s^\tau = w / (1 - b^\tau)$$

#### 4 STRUCTURAL CHANGE MODELS. OUTLINES AND SUGGETSTIONS

This section presents a set of models and methods for analyzing structural change in the forest industry. The time perspective is medium and long-term. The presentation consists of short summarizing descriptions of different models and approaches. The presentation illustrates how the vintage model introduced in section 3 can be used to formulate forecasting and programming models.<sup>1)</sup> The focus of the presentation is the intersection between structural change and capital formation.

##### 4.1 *Regional and sectoral projections based on price forecasting*

We shall here consider a forecasting period extending about 5 years ahead. The starting year is signified by  $t_0$  and the terminal year by  $t_*$ . Suppose that the quasi-supply and quasi-demand structures at date  $t_0$  are known. For every conceivable forecast of how the price variables will develop, one may wish to examine how the supply and demand structures are affected by the price changes.

Let, for a given sector,  $\tilde{p}$ ,  $\tilde{q}$  and  $\tilde{w}$  denote a price projection such that  $p(t_*) = \tilde{p}$ ,  $g(t_*) = \tilde{q}$ ,  $w(t_*) = \tilde{w}$ .<sup>2)</sup> Using  $\tilde{p}$  and  $\tilde{q}$  one may construct an index  $\lambda_\tau$  showing the effect on value added in each index class of the forecasted price changes. It is then possible to calculate the following value added effect of the price prediction:

$$(20) \quad \tilde{F}_\tau = \lambda_\tau F_\tau(t_0), \text{ where } \tilde{F}_\tau \text{ denotes the value added in class } \tau \text{ the terminal year, given constant productivity between } t_0 \text{ and } t_*);$$

$$\lambda_\tau = (\tilde{p} - \tilde{q}a_V^\tau) / (p(t_0) - q(t_0)a_V^\tau)$$

The corresponding gross profit share may be expressed as follows:

---

1) Some of these models are described in detail in Johansson, B, Strömquist, U (1980).

2) These price variables may, in addition, be specified for each separate region.

$$(21) \quad \tilde{b}_\tau = \left[ \tilde{F}_\tau - \tilde{w} s_\tau(t_0) \right] / \tilde{F}_\tau$$

Since (21) is calculated specifically assuming constant productivity,  $\tilde{b}_\tau$  may have changed from the initial position  $b_\tau(t_0)$   $\xi_\tau$  of that  $\tilde{b}_\tau$   $\xi_\tau$ . If the ambition is to restore the original quasi-supply structure, it becomes necessary to utilize reinvestment programmes which bring the establishments back to their initial profit share position. In addition one may formulate investment programmes which expand the production capacity, and which bring about a desired employment level as well as a desired form of the quasi-supply curve.

Suppose now that we have estimated, for each class  $\tau$ , the capacity utilization in the initial year  $t_0$ . Let  $u_\tau(t_0)$ ,  $0 \leq u_\tau \leq 1$ , be a capacity coefficient for index class  $\tau$ . It is then possible to determine the effect of a capacity utilization shift between year  $t_0$  and  $t_*$  in the following way:

$$(22) \quad \tilde{F}_\tau = \tilde{F}_\tau / u_\tau(t_0), \text{ where } \tilde{F}_\tau \text{ signifies the value added that will obtain at full capacity,}$$

$$\tilde{b}_\tau = \left[ \tilde{F}_\tau - \tilde{w} a_s^\tau \bar{x}_\tau(t_0) \right] / \tilde{F}_\tau$$

where  $\bar{x}_\tau(t_0)$  signifies the full capacity level in year  $t_0$ .

Obviously, investment programmes should be calculated on the basis of (22) rather than from (20)-(21).

#### 4.2 *Projections of regional prices on wood*

The projections in the previous section contain a forecast,  $\tilde{q}$ , of how the input price will change during the forecasting period. The consistency of such a forecast may be checked by considering the interaction between the supply of wood and the demand for wood. The latter will reflect different production levels in the forest industry as a whole.

As a starting-point, let us introduce a forecast showing the cost structure of the harvesting process in the terminal year. For each region such a forecast may be formulated as a step-wise

cost function of the type illustrated in Figure 8. Such a cost function could be regarded as a function describing the supply of wood.

Figure 8 A forecast of the cost function of wood harvesting in a region

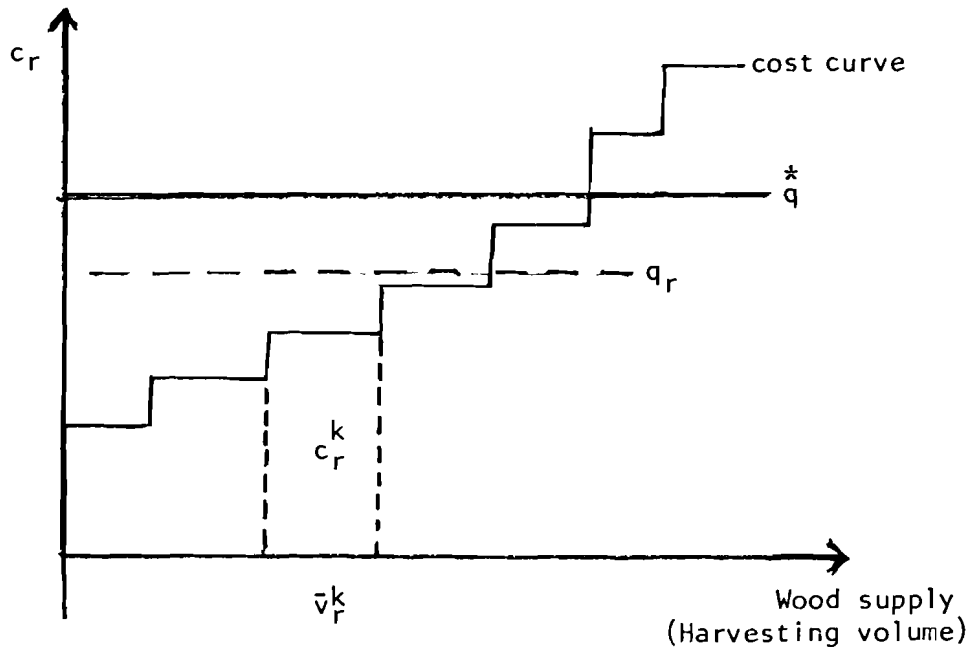

$q^*$  = supply price on the world market (including costs of transportation to Sweden)

$q_r$  = regional supply price (excluding transportation costs)

$v_r^k$  = feasible supply of wood from harvesting area k

Figure 8 illustrates a wood supply curve showing the unit cost,  $c_r^k$ , for each specified interval,  $v_r^k$ , of the supply axis. If k signifies a marginal harvesting area, we may assume that the supply price in region r will be higher than  $c_r^k$ . For each region we may specify a transportation cost coefficient,  $f_{rg}$ , such that the "spot price"  $c_r^k$  is transformed to a destination price  $c_{rg}^k$  in the following way

$$(23) \quad c_{rg}^k = c_r^k f_{rg}, \text{ where } r \text{ denotes delivering region and } g \text{ destination region.}$$

Let  $c_r$  be a regional cost function such that  $c_r^k = c_r \left( \sum_{i=1}^k \bar{v}_r^i \right)$ , where  $\bar{v}_r^i$  denotes a supply quantity. Then (23) defines, in a system with  $n$  regions, an  $n$ -tuple of destination-specified cost function such that  $c_{rg} = f_{rg} c_r$ . Since each region is a potential supplier, we end up with an  $n \times n$ -matrix of cost functions  $c = \{c_{rg}\}$ .

Going back to (18) we may specify a function  $\varphi_r$  for each region  $r$  such that

$$(24) \quad \varphi_r^k = \varphi_r \left( \sum_{\tau=1}^k v_r^\tau \right) \text{ where } v_r^\tau \text{ is a quantity consumed (demanded) in region } r$$

Assume that  $\varphi_r$  is formulated as a non-increasing function. Then  $c$  represents a potential supply system and the vector  $\varphi = \{\varphi_r\}$  represents a regional demand system. The problem of finding a vector of regional prices  $q = \{q_r\}$  may be approached as a generalized transshipment problem. Disregarding the question of formulating a practically solvable model, the following optimization problem may be used as a reference system:

$$(25) \quad \min \sum_k \sum_r \sum_g c_{rg}^k z_{rg}^k, \text{ s.t.}$$

$$\sum_r z_{gr}^k \leq \bar{v}_g^k, \text{ all } g, \text{ and all } k;$$

$$\sum_k \sum_g z_{gr}^k \geq \sum_\tau v_r^\tau = \phi_r(q_r), \text{ all } r;$$

$$q_r \geq \max \left\{ c_{gr}^k : z_{gr}^k > 0 \right\};$$

where  $\phi_r$  is defined from the relation  $q_r \leq \varphi_r^\tau = \varphi_r \left( \sum_{i=1}^\tau v_r^i \right)$ .

#### 4.3 *Regional investment programmes for industry sectors*

In section 4.1 we have sketched how projections of value added and gross profits in vintage classes may be derived from different price forecasts. In this section we shall show how this type of projections can be utilized in an analysis of regional investment programmes. The type of model sketched here is intended to describe how regional employment targets can be fulfilled with the help of regional capital formation in industry sectors.

It is possible to outline a framework in which models can be selected according to the following alternative perspectives:

- Intersectoral and interregional allocation of investments
- Intersectoral allocation of investments in one region
- Interregional allocation of investments in the forest industry.

In order to illustrate the approach we shall select a model version which specifies an employment goal,  $\hat{S}_{jr}^*$ , for each industry sector  $j$  in one single region  $r$ . However, from the outline of the model it is possible to imagine how other versions may be obtained.

With regard to region  $r$ , sector  $j$ , and index class  $\tau$ , we first consider the following projection of the kind described in section 4.1:

$$(26) \quad \begin{aligned} F_{jr}^\tau &= \text{value added at full capacity,} \\ S_{jr}^\tau &= \text{employment at full capacity,} \\ 1/\alpha_{jr}^\tau &= \text{labour productivity.} \end{aligned}$$

We next consider technical coefficients which may be obtained by combining external information with empirical estimates of the vintage model outlined in the previous sections:

$$(27) \quad \begin{aligned} k_{jr}^\tau &= \text{investment coefficient of sector } j, \text{ class } \tau; \\ k_{jr}^* &= \text{investment coefficient of new establishments in} \\ &\quad \text{sector } j; \end{aligned}$$

$1/\alpha_{jr}^*$  = labour productivity in new establishments, sector j ;

$\rho_j$  = interest requirements with regard to investment in sector j.

Finally the following variables are introduced:

(28)  $\Delta\mu_{jr}^\tau$  = productivity increase in sector j, class  $\tau$ ,

$$\mu_{jr}^\tau = 1 + \Delta\mu_{jr}^\tau ;$$

$b_{jr}^\tau$  = gross profit share in sector j, class  $\tau$ ;

$b_{jr}^*$  = gross profit share in new establishments, sector j ;

$I_{jr}^\tau$  = capital formation in sector j, class  $\tau$ ;

$I_{jr}^*$  = capital formation in new establishments, sector j ;

$\Delta S_{jr}^*$  = employment in new establishments.

The relation between investment and labour productivity is assumed to have the following form with respect to the terminal year  $t^*$ :

$$(29) \quad I_{jr}^\tau = k_{jr}^\tau \Delta\mu_{jr}^\tau S_{jr}^\tau / \alpha_{jr}^\tau, \text{ all } j \text{ and } \tau$$

$$I_{jr}^* = k_{jr}^* \Delta S_{jr}^* / \alpha_{jr}^*, \text{ all } j$$

By definition the gross profit shares are determined as follows:

$$(30) \quad b_{jr}^\tau = 1 - \tilde{w}_{jr} \alpha_{jr}^\tau / \mu_{jr}^\tau$$

$$b_{jr}^* = 1 - \tilde{w}_{jr} \alpha_{jr}^*$$

We may assume that the employment targets of region r have been selected in such a way that all production can be sold at the forecasted price. With this assumption we introduce an objective function, in (31), which indirectly puts negative weights on investment costs and positive on gross profits:

$$(31) \quad \text{Min} \quad \sum_{j, \tau} \rho_j l_{jr}^\tau + \sum_j \rho_j l_{jr}^* \\ - \sum_{j, \tau} b_{jr}^\tau \mu_{jr}^\tau S_{jr}^\tau / \alpha_{jr}^\tau - \sum_j b_{jr}^* \Delta S_{jr}^* / \alpha_{jr}^*$$

To this function we add the following sectoral constraints together with the associated shadow prices:

$$(32) \quad (i) \quad S_{jr} = \Delta S_{jr}^* + \sum_\tau S_{jr}^\tau; \gamma_{jr}$$

$$(ii) \quad \tilde{S}_{jr}^\tau \geq S_{jr}^\tau; \delta_{jr}^\tau$$

$$(iii) \quad \Delta \bar{S}_{jr} \geq \Delta S_{jr}^*; \delta_{jr}^*$$

Constraint (i) reflects the employment target and  $\gamma_{jr}$  may interpreted as an employment subsidy or tax, depending on its sign. Constraints (ii) and (iii) reflect capacity limits in old and new establishments. The shadow prices  $\delta_{jr}^\tau$  and  $\delta_{jr}^*$  denote gross profits minus capital costs and subsidies per employed. The following optimum conditions characterize the solution of the programming model

$$(33) \quad \left[ S_{jr}^\tau \quad \rho_j k_{jr}^\tau \Delta \mu_{jr}^\tau / \alpha_{jr}^\tau - \mu_{jr}^\tau / \alpha_{jr}^\tau + \tilde{w}_{jr} + \delta_{jr}^\tau - \gamma_{jr} \right] = 0$$

$$\Delta S_{jr}^* \left[ \rho_j k_{jr}^* / \alpha_{jr}^* - (1 - \tilde{w}_{jr} \alpha_{jr}^*) / \alpha_{jr}^* + \delta_{jr}^* - \gamma_{jr} \right] = 0$$

The basic part of the solution concerns the distribution of investments  $l_{jr}^\tau$  and  $l_{jr}^*$  for all  $j$  and  $\tau$ . Moreover, we may focus the interest on the employment subsidies  $\gamma_{jr} \tilde{S}_{jr}^\tau$ . It also possible to consider subsidies exclusively going to establishments such that  $\delta_{jr}^\tau = 0$ .

Due to lack of space we shall not discuss solution algorithms or the character of the solution. However, in Figur 9 a solution is illustrated for one sector. We should also add that interesting extensions of the model can be obtained by introducing constraints of integer type and by considering a sequence of several periods. In its present form



Figure 9 Illustration of a solution to the programming model

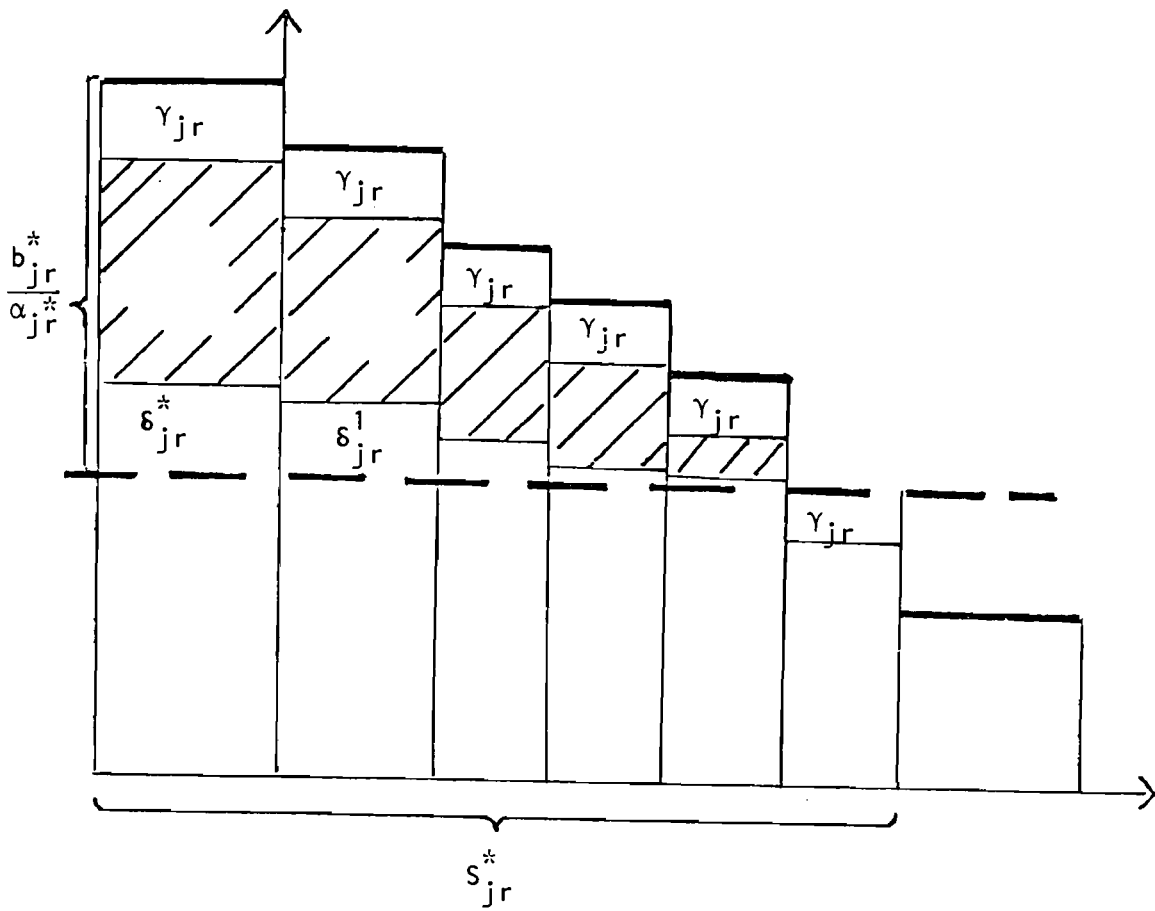

the model could be used to trace the effects of alterations of the employment targets,  $S_{jr}^*$ , and of the assumptions about technical development reflected by the equations in (29).

#### 4.4 *Intercation between structural change models*

In section 4.1 a "projection model" is introduced and specified in (20-22). The projections in this model may be combined with objectives concerning (i) the change of production volumes, and (ii) the distribution of value added and employment over vintage classes in a sector. In order to fulfil these objectives it may be necessary to shut down certain establishments and to increase the capacity and productivity in new and already existing establishments. If a capital formation analysis is added to the projection model, it becomes possible to derive investment programmes which satisfy the given objectives.

It is possible to connect a dynamic input-output model with the projection model. Capacity requirements and changes of input coefficients in the input-output model may then be determined on the basis of the investment analysis in the projection model.

Suppose that the input-output model includes relations describing the price formation process. One may then form a closed loop such that the results from the input-output model are used to determine the price and quantity projections which enter the projection model. This kind of closed chain is illustrated in Figure 10. The figure also shows how the "employment policy model", outlined in (26) - (33), may be connected to the model system discussed.

Figure 10 Interaction between structural change models

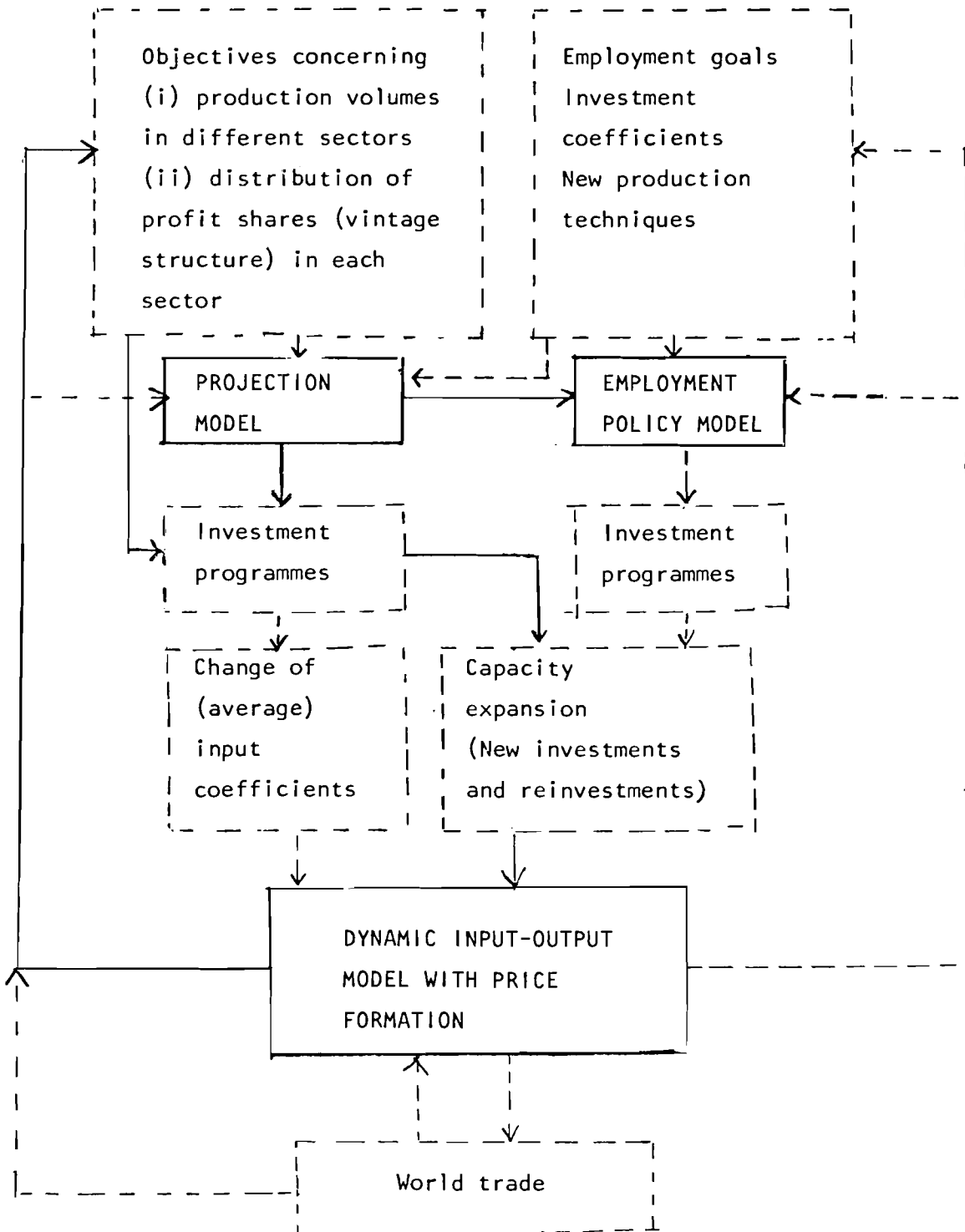

## 5 THE ORGANIZATION OF DATA AND A DYNAMIC DESCRIPTION OF THE STRUCTURAL CHANGE PROCESS

The type of analyses and the models suggested in this paper require a set of detailed and consistent data about the industry. We shall, in this final section, describe some of the information available in Sweden's Industrial Statistics. We shall also show how we have organized this information. Finally, we shall indicate how this organization of data may be utilized to formulate a dynamic model of the structural change process.

### 5.1 *A cross-classification principle*

In this section we shall describe an already existing information system based on information about individual establishments.<sup>1)</sup> The information system is used for sectoral and regional analyses of the industry. Therefore the system contains a cross-classification of each establishment with regard to

- Region and county
- Sector
- Time (year)
- The gross profit share of each establishment  
(vintage classification)

In addition the informationsystem contains a cross-classification of the profit share of each establishment for pairs of years. This information is summarized in matrices,  $X(t)=\{x_{ij}(t)\}$ , of the following type:

---

1) This system is characterized in Johansson B, Strömquist U (1980). The system is designed not to reveal information about individual establishments.

(34)  $x_{ij}(t)$  specifies (for a region and/or a sector) the number of establishments which belonged to index class  $i$  in year  $t-1$  and index class  $j$  in year  $t$ ;

$i \in \{M, *\}$ , where  $M = \{1, \dots, n\}$  is the set of vintage indexes introduced in (5) and where  $i = *$ <sup>1)</sup> signifies a class which contains the establishments entering the market in year  $t$ ;

$j \in \{M, 0\}$ , where  $i = 0$ <sup>1)</sup> signifies a class which contains the establishments leaving the market in year  $t$ .

To every matrix  $X(t)$  one may specify three different types of associated matrices denoted by  $Y(t) = \{y_{ij}(t)\}$  such that

(35) for the set of establishments belonging to cell  $(i, j)$

$y_{ij}(t)$  specifies:

- the number of employed, or
- the wage sum, or
- the value added

One may also consider matrices  $I(t-k) = \{I_{ij}(t-k)\}$ , where  $I_{ij}(t-k)$  denotes the capital formation year  $t-k$ ,  $k \geq 0$ , in the set of establishments belonging to cell  $(i, j)$ <sup>2)</sup>. With this latter type of matrices one may estimate how the investment process affects the vintage position of establishments, with a time-lag of  $k$  years.

Combining the three types of  $Y$ -matrices one may determine a quasi-supply and quasi-demand curve for each row  $i$  of the original matrix  $X$ . Utilizing the marginal distributions of the type  $x_j = \sum_i x_{ij}$  one may calculate the over-all quasi-supply and quasi-demand curves associated with each matrix which may refer to a region and/or a sector.

---

1) In short,  $i = *$  denotes "entry" and  $i = 0$  denotes "exit".

2) The existing information system does not yet include investment variables, but is planned to do so.

## 5.2 *Dynamic descriptions of the structural change process*

The matrices specified in (34) and (35) may be used to check the relevance and reliability of the vintage model assumption introduced in section 3. In particular, the matrix  $X(t)$  can be used to estimate the transition probabilities  $h_{ij}(t)$ , introduced in (a.2). This can be done in the following way:

$$(36) \quad h_{ij}(t) = x_{ij}(t)/x_i(t-1), \quad i \neq j;$$

$$h_{ii}(t) = [x_{ii}(t) + x_{*i}(t) - x_{i0}(t)] / x_i(t-1);$$

$$x_i(t-1) = \sum_{j \in M} x_{ij}(t) + x_{i0}(t)$$

Analogous probabilities may be estimated from the three types of Y-matrices. We then end up with four matrices of the type  $H(t) = \{h_{ij}(t)\}$ . With this construction the structural change process can be described as a transition process such that

$$(37) \quad x(t) = x(t-1)H_x(t),$$

$$y(t) = y(t-1)H_y(t)$$

The system in (37) may be used to analyze structural change scenarios in the form of quasi-supply and quasi-demand curves related to stable solutions of the transition system.<sup>1)</sup>

In order to incorporate the fact that the gross profit share is influenced by market fluctuations, the transition probabilities may be estimated as functions of short run changes of the price variables  $p(t)$ ,  $w(t)$  and  $q(t)$ . In this way it is also possible to observe the degree to which  $a_s(t)$  and  $a_v(t)$  are influenced by variations in the capacity utilization.<sup>2)</sup>

---

1) See Johansson B, Holmberg I (1980).

2) Observe that (a.1) assumes these coefficients to be constant.

REFERENCES

- Johansen L (1959), Substitution versus Fixed Production Coefficients in the Theory of Economic Growth: A Synthesis, Econometrica 27 No 2, pp 157-177
- Johansen L (1972), Production Functions, North-Holland
- Johansson, B, Holmberg I (1980), The Distribution of Vintages and Profits of Establishments in Regions. A Stochastic Model, University of Gothenburg (presented at an IIASA-conference in March 1980)
- Johansson B, Strömquist U. (1980), Vinster och Sysselsättning i Svensk Industri, SIND, Stockholm (Profits and Employment in the Swedish Industry)
- Phelps E S (1962), The New View of Investment: A Neoclassical Analysis, The Quarterly Journal of Economics L XXXIII,4, pp 548-567
- Phelps E S (1963), Substitution, Fixed Proportions, Growth and Distribution, International Economic Review, pp 265-288
- Salter W E G (1960), Productivity and Technical Change, Cambridge
- Solow R M (1967) Some Recent Developments in the Theory of Production, in Studies in Income and Wealth, vol 31, (ed) Brown M.

## Wood Supply and Demand in Sweden

### Introduction

Since the beginning of the 1970's the annual wood consumption capacity in Sweden has greatly exceeded forest growth. This imbalance has been aggravated by rising oil prices which make wood competitive also as a fuel.

The way forestry, the forest-based industry and government handle this situation will have significant effects on the whole economy. The forest-based industry has in several respects something of a key position.

First, the balance of trade is heavily resting on this industry. It gives rise to 20 per cent of the exports but only 2 per cent of the imports. Net earnings correspond to the cost of the oil import.

Second, the employment just makes up to 2 per cent of the country's total. But a large part of this is in regions with a high rate of unemployment. A number of small towns in those areas stand and fall with this industry.

Finally, the pulp and paper industry is both a main energy consumer and supplier. 40 per cent of total industrial energy use is due to it, but more than 60 per cent of the fuel it uses is own by-products like bark, spent liquors etc. 30 per cent of the own electricity consumption is generated with such wood-based fuels.

The shortage of raw material facing the forest-based industry makes it necessary to reduce capacity or/and to increase supply. This has created demands on the government to intervene in various ways.

To mitigate the effects of a cutdown of capacity, the government is asked to support, sometimes even to enforce, a vertical expansion of the industry towards further manufacturing of semi-finished products



which are now being exported. This is however no simple task. Competition is often already troublesome on the markets for finished products. In the case of paper there are even some threats of increasing trade barriers as a result of a too rapid increase of the Swedish paper-making capacity.

But measures have also been proposed for preventing a reduction in industry's wood-consumption capacity. The industry itself and others have suggested a regulation of the use of wood for heating purposes in order to establish that only wood-materials without other use are burned. To augment the supply various forms of subsidies have been proposed. These aim to increase cuttings in periods of peak demand and to stimulate growth-promoting investments.

In this paper I will discuss some aspects of the problem of how to avoid or moderate a decrease of the existing capacity. My first point is that the problem is not the result of an actual deficit of trees, but of the policy to have a balance at each time between growth and harvest. My second point is that a regulation of wood-burnings may well be unnecessary. This is the suggestion offered from an estimation of industry's short run wood demand function.

#### Supply vs. industry's capacity

The parliament decided in 1979 that the ambition of the forest policy will be to achieve an average harvest level of 75 million m<sup>3</sup> (gross volume; inclusive bark and tops, but exclusive roots, stubs and branches). This level corresponds to current growth (but exceeds expected growth at the turn of the century).

This level of supply amounts to about 90 per cent of industry's current full capacity wood consumption (a supply of 60 million m<sup>3</sup> - net volume; exclusive bark - versus 66,4 million m<sup>3</sup> (net) for full capacity consumption). This share becomes even smaller if the comparison takes account of differences between regions and tree species. Table 1 shows balances for the three regions defined in the map. The potential supply of pine-wood will only suffice for an 80 per cent utilization of total capacity. Instead, leaf-wood is in excess in all regions. There are also important regional differences. The pine-wood balance is better in northern Sweden, but worse in the two other regions.

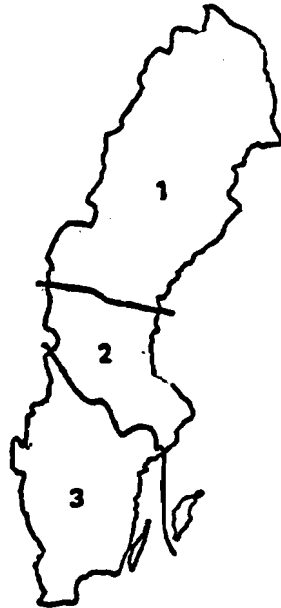
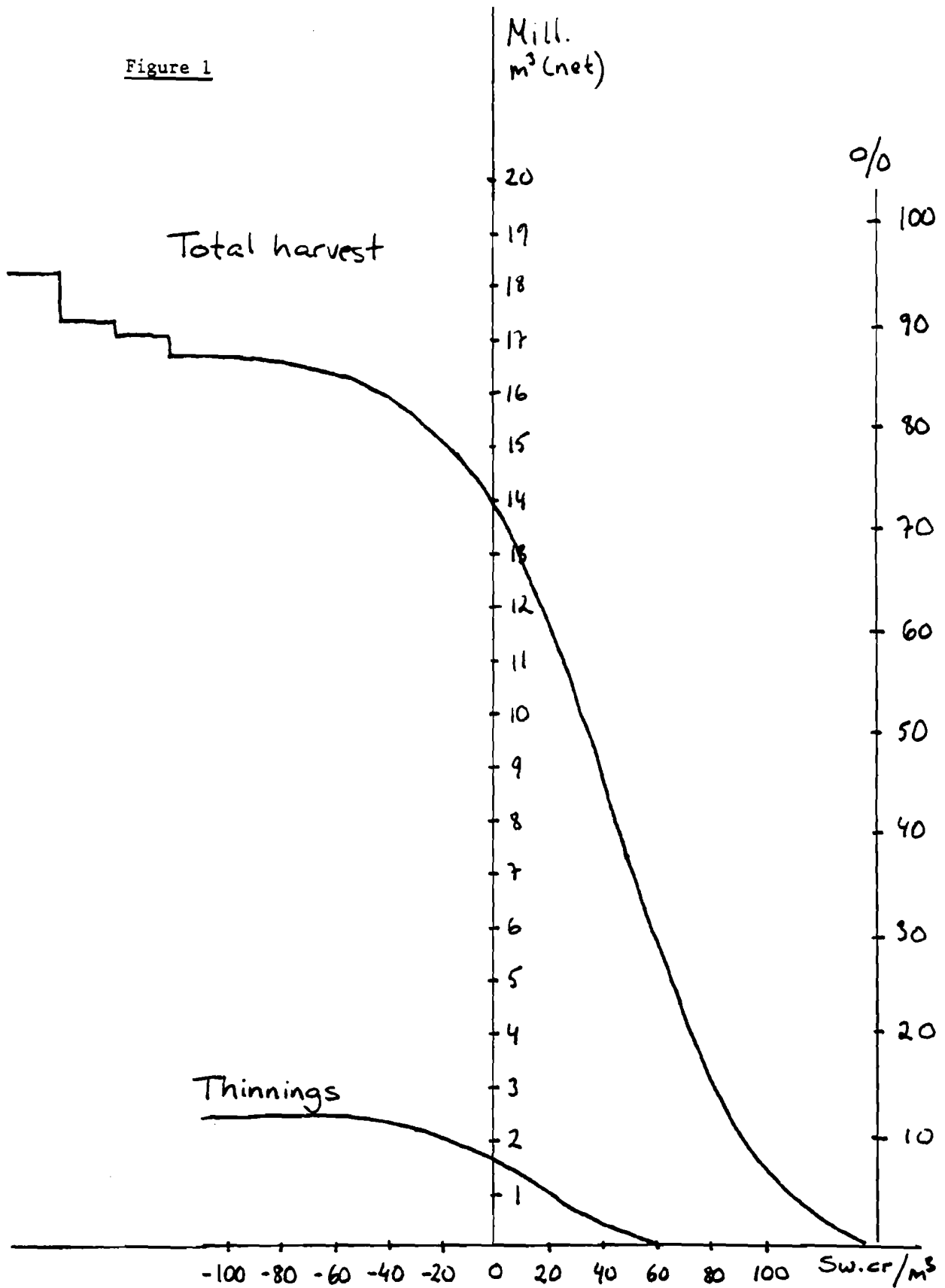

Table 1. Millions of m<sup>3</sup> (net)

	Region 1			Region 2			Region 3			Total		
	Conifer	Leaf	Total	Conifer	Leaf	Total	Conifer	Leaf	Total	Conifer	Leaf	Total
Wood consumption												
100 %	17.0	2.0	19.0	16.1	0.8	16.9	27.9	2.6	30.5	61.0	5.4	66.4
85 %	14.5	1.7	16.2	13.7	0.7	14.4	23.7	2.2	25.9	51.9	4.6	56.4
Aimed supply	15.8	2.8	18.6	11.9	1.9	13.8	21.4	5.4	26.8	49.1	10.1	59,2

This regards the level of supply to which the parliament is aiming. The government forest policy (working through prohibitions to harvest not fully grown forests - for the moment defined as having a growth-rate over 3 per cent -, replanting duties, tax policy, industrial policy, etc.) just sets up a frame for the actual wood scarcity. The actual scarcity is of course an economic question; depending on the shape of the demand and supply functions. An estimated supply-curve for region 1 is shown - in an unconventional fashion - in figure 1. It shows the net revenue per unit to the suppliers for different supplied quantities when price is unchanged. The net revenue is the current price (1979) less the cost of cutting, transport and necessary replanting. The two curves in the figure demonstrate how marginal cost increases (net revenue when price is unchanged decreases) when supply is increased.

Figure 1



The supply at the current price is given from the intersection between the supply curve and the zero-profit line. This amounts to a volume of 14 million cubic meters, corresponding to 72 per cent utilization of industrial capacity. If the price is increased with 20 Sw. crowns the supply goes up one million cubic meters. The figure shows that the supply elasticity is very high for the following quantities up to the upper boundary - which is the aimed level set up by the parliament. Thus it seems as if the economic shortage of wood relative to industry's capacity is significantly higher than table 1 points out.

Industrial capacity is not the same as real production. Because of especially the four year long recession 1975-1978 the total wood input to industry during the 1970's was less than the forest growth. Market demand was in other words a stronger constraint than the growth of the biomass.

The relief in the balance situation was however only temporary. Demand is expected to be growing during the 1980's. The sales potential 1982 has been estimated in an official report to correspond to a wood consumption of 70 million m<sup>3</sup> (net) or 90 million m<sup>3</sup> (gross). If such a level of sales and production will come true depends of course mainly on which prices the industry sets on its output. But since wood costs for most products make up more than 50 per cent of total costs, this means that to a great extent it is a question of the price elasticity of wood supply versus the elasticity of demand on industry's products.

#### Unused reserves

The industry has paid great attention to find out how wood supply can be augmented. Import of wood-chips has been increased and now amounts to 3 million m<sup>3</sup> (whereas export comes up to 2 million m<sup>3</sup>). This is however not expected to be possible to substantially increase any further. Another fiber-source which has been thoroughly investigated is waste-paper. Some papermills have the last years invested in capacity for deinking of newspapers and magazines. The unused amount which could be recycled is estimated to about 300,000 tons. This means a saving of more than half a million m<sup>3</sup> wood.

A very significant reserve is the biomass which is now left in the forests after the fellings. The total volume of this is estimated at 35 million m<sup>3</sup>. For ecological, technological and economical reasons most of this cannot be taken charge of. Some 7 million m<sup>3</sup>, mainly stubs, roots and small trees from thinnings, can be used for pulp and particle board. This volume and 9-10 million m<sup>3</sup> in addition can also be used as fuel.

Forest growth can be increased in the long run, through better planting methods, more fast-growing plants, thinnings, etc., as well as in the "short" run of about 10 years, particularly through draining and fertilizing.

These measures have the disadvantage of raising marginal costs in forestry. Collecting and transport costs for whole-tree components are in some cases fully comparable with those of conventional roundwood, but typically they lie above. A more intensive forestry is not only associated with higher investment costs but also with a significant degree of uncertainty regarding the effects on environment and on the sensitivity for diseases, weather, etc.

Hence there is a conflict between this way to increase supply and the low price on industry's output which is required to maintain and increase market squares. Since Sweden is already using more marginal land and more intensive cultivation methods than the main and price-leading competitors, this conflict is likely to be crucial.

One way to get around this dilemma, from industry's point of view, is to let tax payers subsidize forestry. If this is the strategy of the industry, it has apparently been rather successful during the last years.

#### The "balance philosophy"

There is, however, another way to increase supply without raising marginal costs.<sup>1)</sup> This is to loose the tight connection between annual growth and cuttings. Because of a favourable age distribution, with a high portion of fully-grown trees (and, on the other side, a small

---

1) A number of qualifications should be made to this statement, but I omit them here.

portion of medium-old trees), it is possible to greatly increase fellings for one or two decades on non-marginal land.

A relaxation of the upper bound constraints on fellings was actually proposed in 1973 in an official report to the government. Two main arguments were put in favour of this proposal:

The first point was that it is a bad use of capital to keep a big amount of slow-growing trees. The money they represent can be used in more profitable ways. Promising market projections at 10 to 20 years' sight and a large industrial capacity guarantee that it will really be possible to transfer the old forest capital to other uses.

The second point concerned the long-run outlook for forest-based industry. According to the report there are two big threats to survival in the development of various substitutes to paper and wood articles (such as electronics), and the ongoing building of the infrastructure necessary for low-cost pulping in tropical countries (where trees do not just live on the charity of the Gulf Stream and where for that reason growth is considerably more rapid than in Sweden).

This long-run uncertainty, the report concluded, is another good argument for using up the current surplus of old trees. Another policy implication, it could be added, is not to initiate large scale investment programmes and to mainly rest on investments with short pay-off time.

The report was immediately met by very strong criticism claiming that the policy proposed was too short-sighted. A new analysis by a new group was initiated. The final report of this group was delivered in 1978. It advocated a very comprehensive and costly investment programme (which to a large extent would be financed by loans and subsidies from the government). This was due to criticism of among other things the environmental aspects not fully adopted by the parliament. There were, however, no elements in the final decision that could remind anyone of the 1973 proposal.

The report formulated the object of policy as to achieve a high and smooth long-run production. As an operational definition of the long-range aspect, a production programme was demanded to produce a volume of biomass in 2070 as least as big as 100 years earlier. The choice of this criterion was not motivated, although it means a significant restriction on the dynamics of the forestry (the growth period of a tree is longer than 100 years in large parts of the country).

The report did not go deeper into the question of what should be meant by a smooth production over time. Particularly, nothing is said about what wood supply is required to get some sort of even development of employment in industry. The report accepts, however, no large difference between growth and harvest in any period. In the alternative scenarios that were studied the biomass is in no case allowed to decrease to less than 10 per cent under the 1970 level.

An alternative production strategy

This "balance philosophy" is however not necessarily a good approximation to a policy that gives a high, even and long-range production. This is shown in figures 2 and 3.

Figure 2

Yearly harvest,  
million m<sup>3</sup> (gross)

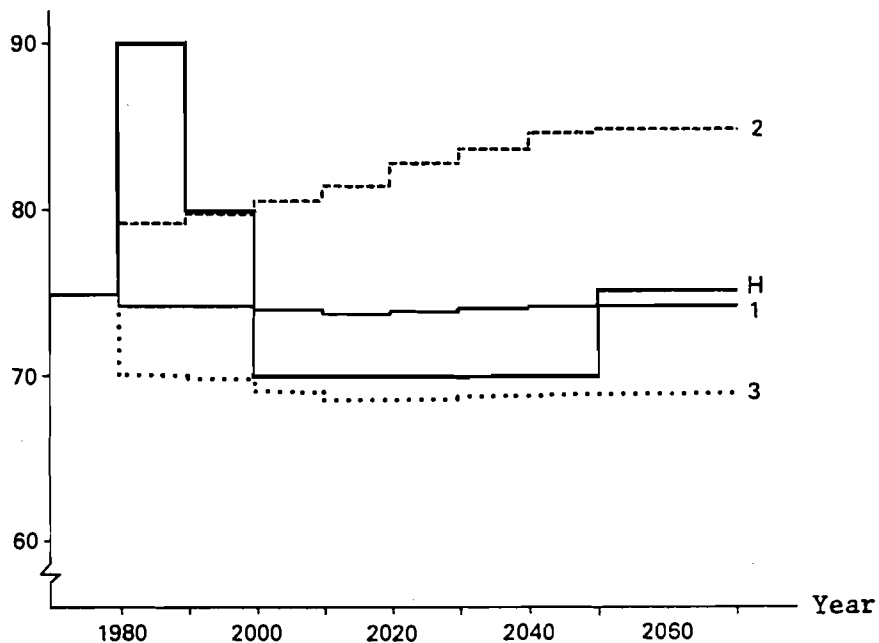

Production programmes 1, 2 and 3 are the ones which were studied in the report. Programme 1 is the reference scenario, which assumes an unchanged investment level and a constant production over time. Programme 2 is the recommended programme, where forest growth and cuttings are successively raised as a result of the large-scale investment programme. Programme 3 gives a smaller production than in the reference scenario because of a higher ambition to take environmental conservation into consideration.

The different strategies were studied in a very detailed computer model describing the forest growth. Given a specification of cuttings and various growth-promoting activities on different types of land, the model makes a ten year forecast of the development of the total biomass. The runnings can be repeated to get very long forecasts.

As a comparison to the three alternatives in the report, a fourth programme, programme H, has been studied in the model on my request. This follows the strategy of the 1973 report. Cuttings are high during the next two decades and then go down. Investments are the same as in the reference scenario.

Figure 3 shows the outcome. The total volume of the biomass is falling faster in programme H, compared to the others, till the turn of the century. From then, however, it increases. This growth is more rapid and starts earlier than in the "balance scenarios". At the terminal date the stock is not just higher than the 1970 level but also exceeds the stock of the other programmes. This result is of course due to lower average age of the trees (and therefore higher growth rates, which is the result of the fellings during the first two decades).



Figure 3

Total biomass,  
million m<sup>3</sup> (gross)

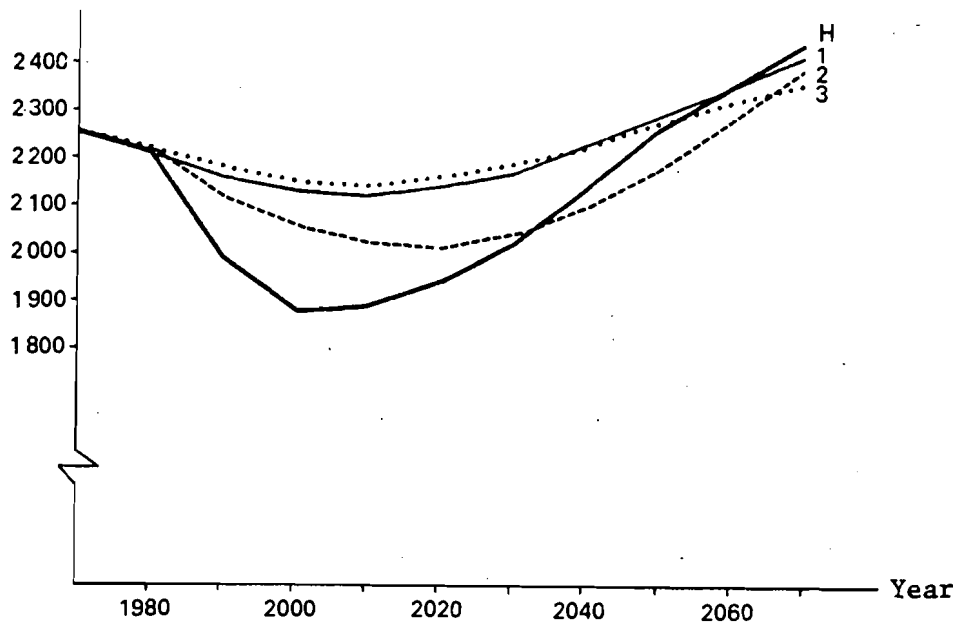

Programme H gives a wood supply during the next decade which will suffice for full utilization of the current capacity in industry.

A sharp and immediate reduction in capacity, which is necessary even in alternative 2, can be avoided. This means that no new investment funds are required to replace production and employment opportunities in rather new plants which are scrapped before they otherwise would be. From this point of view alternative H is the most "smooth" programme.

Programme H also, as figure 3 showed, fulfils the "long-range" criteria of the report. It is even a strong candidate for being the "best" programme.<sup>1)</sup> If timber prices are assumed to be constant over

1) To choose the "best" it is necessary to make specified assumptions about the costs associated with the adjustments to a changing harvest level, future prices (or "social valuation") on timber and the rate of interest.

the 90 year period, the discounted value of alternative H is higher than that of alternative 1 at every non-negative rate of interest. At an interest rate of 5 per cent the discounted value of the gross income of alternatives H and 2 breaks even. The costs of the latter are considerably higher so net incomes will break even on a lower, perhaps not even positive, rate of interest. A high uncertainty regarding future prices (which raises the risk premium of the interest rate) or an expectation of falling prices in the long run will make programme H even more favourable.

From the environmental aspect, alternative H will mean a larger total harvested area the next two decades. Since fellings have many negative effects on the environment, this is a great disadvantage. On the other hand, the very criticized measures in alternative 2 will be cancelled or at least postponed. Even a short delay is useful, since a main criticism is that too little research has been devoted to the ecological and long-run effects of that alternative before implementation.

#### Industry's short-run demand function

The seeds of policy H have hitherto not fallen into good grounds. The problem of raw materials shortage remains. Thus, the next question is to what extent this is worsened by the foreseen new (rather returned) competition from heating stations.

The problem can be illustrated by a simple supply-demand scheme. The E-E-curve in figure 4 represents industry's demand for wood, while U-U is the supply curve. The equilibrium is established in point J at the quantity J and the price p. Now the heating station's demand, E'-E, is introduced. The heating stations can bid a higher price than some of the industry plants. The market demand is therefore the broad line E-E'. The new equilibrium means a higher price and a smaller quantity, OA, for industry.

The industry's demand curve is possible to estimate on the basis of the plant specific information which is the input to the official industry statistics.

Figure 4

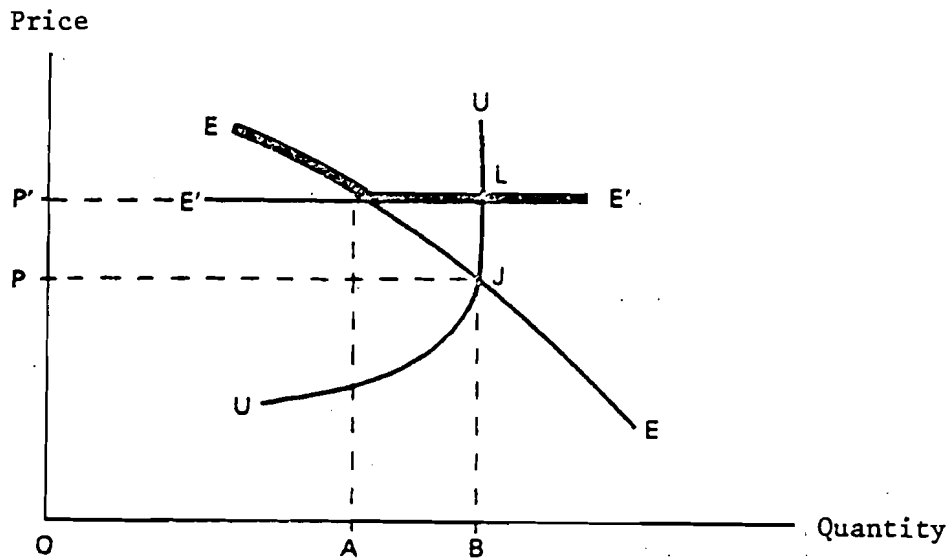
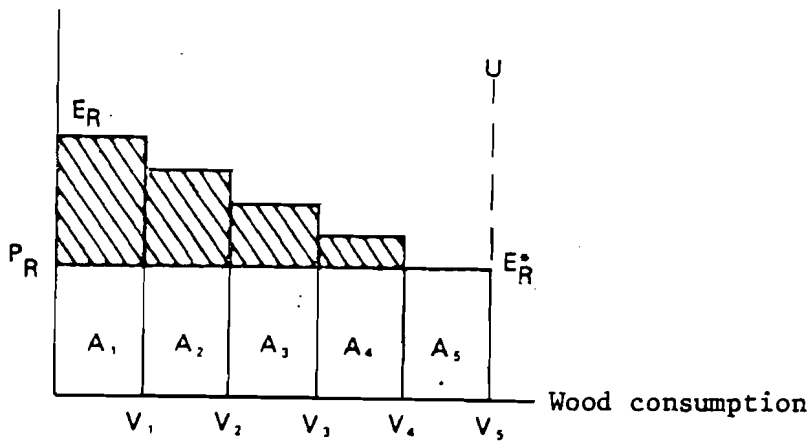

Figure 5 shows a group of plants arranged in order of falling ability to pay for one unit of wood input. The ability to pay, the height of each staple, is the maximum price a plant can pay for the wood when other variable costs are paid. In normal cases, the plant also, besides the cost of the wood input, can cover fixed costs and a certain profit. But in the marginal plant to the right in the figure only the variable costs are covered. This plant is shut down if the price  $P_R$  on wood is raised.

Figure 5

Ability to pay



The  $E_R-E_R^*$  curve formed by the staples is the industry's demand curve. The price  $P_R$  and the quantity  $V_5$  is the market equilibrium that is established by the demand curve and a supply curve  $V_5-U$ . If the supply is diminished, i.e. the supply curve is shifted to the left, a new equilibrium will be set implying a higher price, a smaller quantity of wood input and closing of one (or a part of it) or more plants to the right in the figure.

This scheme is of course a simplification. Besides the measurement problems - to measure the expected prices and costs and the opportunity costs which are relevant to the decision maker - shutdowns is only one of a number of possible reactions to a higher wood price. Other ways can be to improve the efficiency, change output composition, close down one or two production lines etc. This means that the curve  $E_R-E_R^*$  underestimates the industry's ability to pay. This bias is however not likely to be very large.

Figure 6

Sw.cr./m<sup>3</sup> (net)

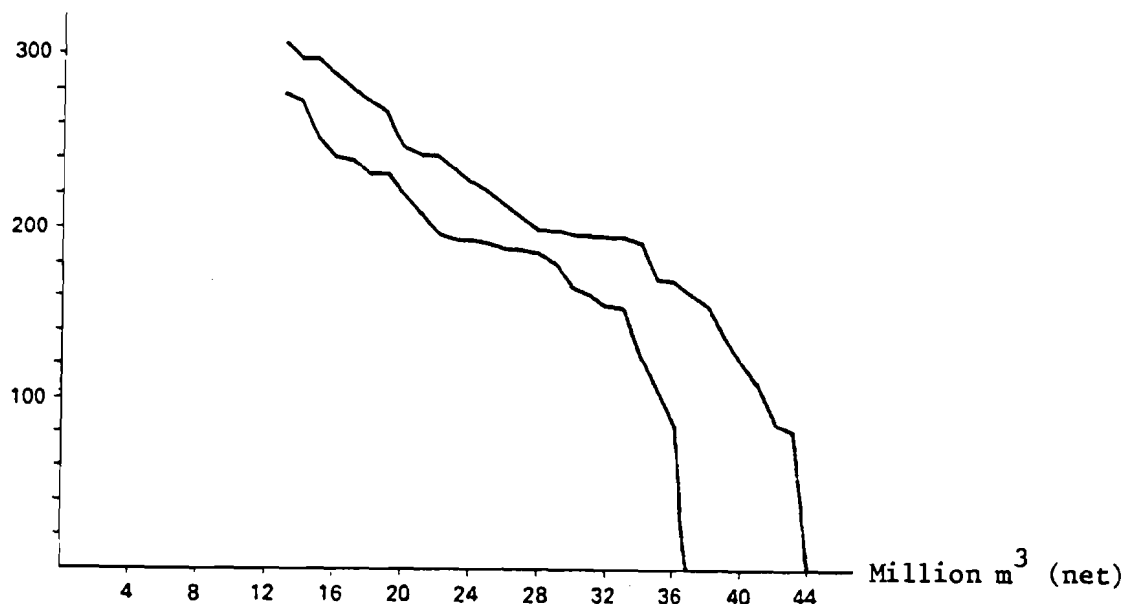

I have estimated the 1979 demand curve<sup>1)</sup> with a linear programming technique. The results are shown in figure 6. The outer curve applies to full capacity utilization in all plants, while the inner curve is estimated on the assumption of 85 per cent utilization. From these curves we can learn that a not inconsiderable part of the industry is run with a deficit in net income when operation costs are deducted. At a wood price of 160 Swedish crowns these plants corresponded to more than 10 per cent of the used wood. This is, with some exceptions, the plants that are in an immediate danger of being closed (and perhaps being replaced by new investments on the same locations).

I have also estimated demand curves for each of the three regions shown in the map which accompanies table 1. The results are summarized in figure 7. The losses of jobs in closed plants that are associated with a certain price on wood are shown in the figure. It can be seen that the "employment elasticity" is very high in region 1, the northern part of Sweden, and considerably lower in the two other regions. At a price of 193 Sw. crs., plants with more than 6,000 employees are shut down. This is two thirds of the industry's total employment in the region. About 5,200 jobs disappear in the interval between 150 (which roughly is the current price) and 193 Sw. crs. The corresponding figure in region 1 is about 700 and in region 2 about 150.

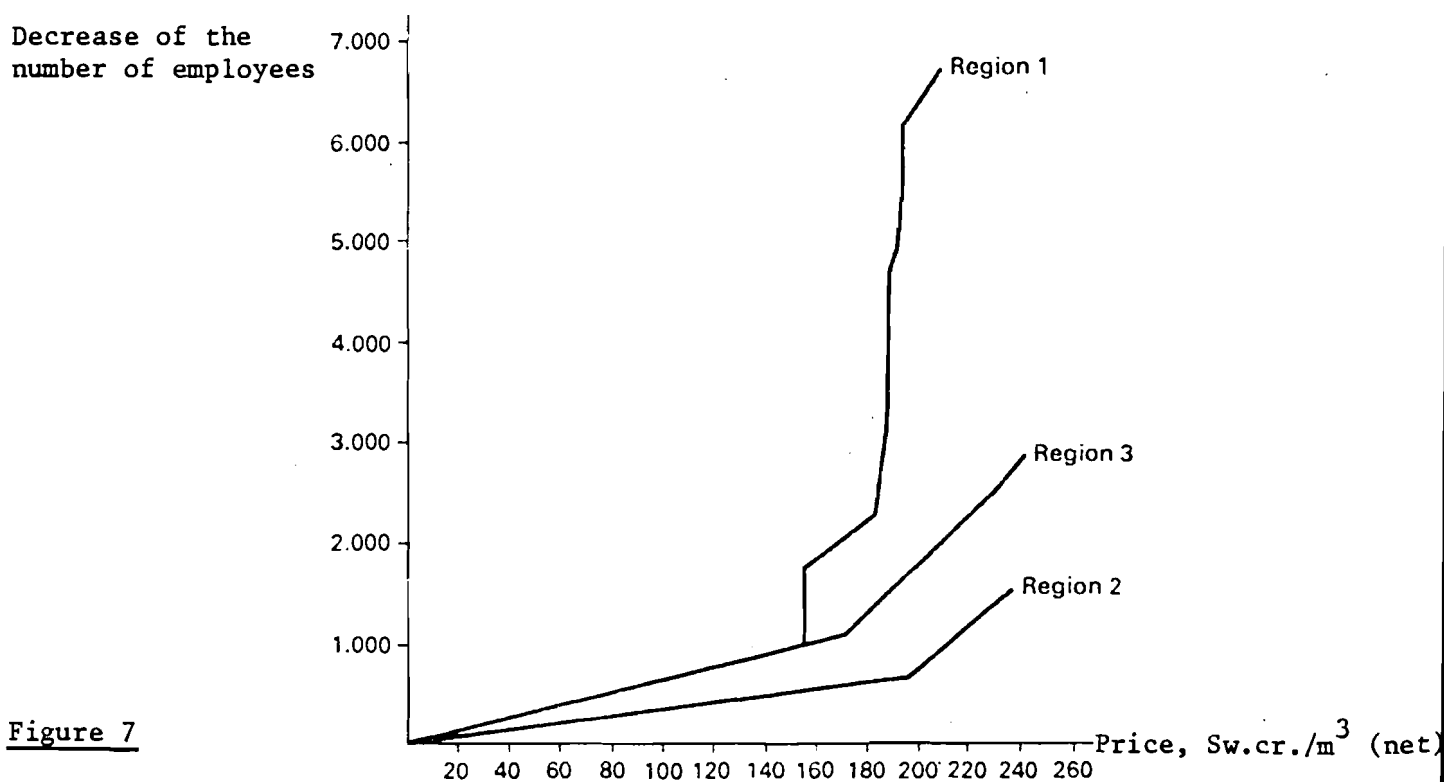

Figure 7

1) Sawmills' demand and demand on leafwood is not included, but for a number of reasons this is not important for the use made here.

These results from the regional estimations are very interesting, since the costs of transporting for instance wood chips are rather high. The very dominant part of the country's population and thus the house heating plants are located to the southern and middle regions. In these regions it will be necessary for the heating plants to pay a very high price to get wood which is now used in the industry. This result indicates that an increase of the wood-based heating will mainly be limited to woodfuels which are of no use for industry - and this even without any regulation. This does not mean that there is no scope for wood-based heating. The unused reserves of tree components that are in "technical, economical and ecological scope" for this use are estimated to 16-17 million cubic meters. This corresponds to 10 per cent of Sweden's oil consumption.

References:

- Hultkrantz, L., (1979), "Arbetslöshet eller miljöförstöring - ett val för skogspolitiken?", Ekonomisk Debatt 1979/1.
- \_\_\_\_\_, (1979), "Fliseldning - hot mot skogsindustrin?", Ekonomisk Debatt 1979/8.
- \_\_\_\_\_, (1979), "Produktions- och sysselsättningsbortfallet vid minskad tillgång till industrived", Statens Industriverk.
- "Mål och medel i skogspolitiken", (1973), Betänkande avgivet av skogspolitiska utredningen, SOU 1973:14.
- "Skog för framtid", (1978), Betänkande av 1973 års skogsutredning, SOU 1978:6.

APPLICATIONS OF SYSTEMS ANALYSIS IN U.S. FOREST SERVICE

ASSESSMENTS AND PLANNING

Clark Row  
USDA Forest Service  
Washington, DC, USA

In recent years the U.S. Forest Service has developed and used a number of system analysis applications for both national and regional modeling of the forest sector and in forest management. Those that this paper will discuss are those used in assessing the national timber situation and in the detailed planning of the publicly owned National Forests under the management of the Forest Service.

The Forest Service, a component of the U.S. Department of Agriculture, is responsible for much of the national situation assessment and planning done in the forestry sector, as well as administration of significant areas of forest (about 74 million hectares), a variety of assistance programs to private landowners, and forestry research. New legislation passed in the last five years has required that previous types of analyses and planning be broadened and strengthened. This could not have been possible without widespread use of systems analysis.

A number of additional systems have been applied to specialized applications and in research. These will not be discussed. Many of the applications discussed have not yet been published in full descriptive form in the technical literature.

The concerns of the Forest Service include all outputs from forest and natural range lands, not just timber. This requires that we employ systems analysis

models of other resources--water, range, wildlife, and recreation. Often these were developed primarily for agricultural analyses and will not be described here. Of major importance is that the task of planning National Forest areas for multiple simultaneous outputs has stretched our capabilities of systems analysis to the fullest. However, without such techniques, analyses that meet the requirements of the legislation would not be possible.

In the following brief descriptions of applications I will also mention areas of active systems development.

#### Applications in resource situation assessment

The objective of the Forest Service's resource assessment just completed this year (USDA Forest Service 1980b) is to measure the capability of the resources covered to produce both market and nonmarket outputs, the trends of resource conditions, demands for outputs, and likely availability of supply, and where possible projection the trend of equilibrium market prices assuming continuation of basic resource management trends, economic growth trends, and other factors.

This was possible to varying degrees for each resource. For some nonmarket outputs data availability and analytical tools sharply limited the analysis. A detailed description of U.S. approaches discusses these limitations and the historical development of the methodology (Row 1977). For timber, however, the assessment covered a large number of factors and was published in considerable detail separately (USDA Forest Service 1980a).



The systems application models do not fall into easy categories. Some accomplished limited tasks, while others integrated diverse information and results of other models. Five aspects of the assessment were heavily dependent on models.

Demands for processed timber products. Basic data on past consumption, exports, and prices of processed timber products were assembled from a variety of statistical sources and original surveys. The primary analytical techniques were econometric procedures. One system, however, merits special attention.

The demand for residential housing was projected by a system called HOUSE (Marcin 1972). Using demographic simulation techniques the model projects the number of various types of households by characteristics related to their preference of type of housing. Using changes in preferences and economic conditions, as well as the inventory of housing units, allowed projection of the need for new housing of various types.

Supply of timber for harvest. Like the demand for wood-based products, the supply of timber is a topic the Forest Service has analyzed periodically for many decades, as well as collected the basic resource data. The basic projection system is the Timber Resource Analyses System (TRAS) (Larson and Goforth 1970) developed several years ago. It is a timber stand projection technique using growth, mortality, and harvest factors and trends by timber size class.

Research has developed a number of potential improved procedures for the dynamic projection of regional timber resource situations. One of the challenges of

future systems analysis applications is to evaluate, improve, and make such new approaches operational.

Processing timber into processed products. Currently our knowledge of this area is embodied in a series of coefficients and factors for product conversion, logging, processing, and transportation costs, and constraints on locational shifts over time.

These types of information is used by the TAMM model described in the next section, but may be incorporated into a major model of the U.S. timber processing industries.

Market equilibrium analyses. A basic problem encountered by the assessment of the timber situation was a method to simulate the supply-demand equilibrium over a number of decades. The basic tool developed, the Timber Market Assessment Model (TAMM) (Adams and Haynes 1979), simulates the entire softwood timber economy. It provides for three stages of production, six demand regions, nine supply regions.

The solution procedure for the TAMM model uses reactive programming, and implementation of quadratic programming that iteratively tests components to see if they improve the solution, a least cost objective.

This systems application has proved invaluable for both the assessment and for a number of policy analyses. A major effort of the Forest Service will be to improve and extend the system.

Multi-resource interactions. One quite apparent fact is that the land resource base in U.S. forestry and range cannot produce all the outputs for which there is demand. Various uses are actively competing for the allocation of land. In an attempt to assess these tradeoffs the Forest Service developed the Multi-resource Use Interaction Model (Ashton 1980). This is a linear programming application with activities representing a very large number of existing and potential land management regimes for a detailed classification of land. This system also is undergoing major refinement.

Management Planning for the National Forests. New U.S. legislation has also required a great expansion of systems development application in National Forest planning.

The planning is being done in a cyclical time schedule within the hierarchy of planning units. At the top is a national plan (called the RPA plan, finished in 1980). Objectives and targets will be disaggregated to regions (9 administrative areas), and 121 administrative National Forest units.

The detailed land and resource management plans to be developed by each National Forest by 1984 must provide alternatives that meet the targets (if economically feasible), but of course at various costs. Some alternatives may show that individual forests may exceed their assigned targets. In addition there are numerous other factors, issues, and concerns that will influence the alternative recommended or chosen for each forest.

National and regional planning. The basic systems tool for budget planning used in the recent RPA analyses and in regional planning is ADVENT (Kirby 1978). It

is also a linear programming application in which the activities are potential major program directions in a number of areas by geographical units. The constraints are budget costs and output targets. It also computes measures of economic efficiency (present net value and rate of return). The model was effectively used to assess program tradeoffs and simulate cost curves for each output.

National Forest Planning. Because the planning of National Forests requires determination of long-term management prescriptions by detailed analysis areas, a more comprehensive approach was required for National Forest planning.

A linear programming application called FORPLAN (Johnson and Jones 1979) was developed from predecessor models that merely allocated and scheduled management on the basis for timber, particularly TIMBER-RAM (Navon 1971). Over the last several years FORPLAN has been refined to permit greater flexibility in management prescriptions, input options, cost and price routines, and target and spatial constraints.

The Forest Service is requiring that FORPLAN be used on all National Forests. Detailed instructions on preparation of input and formulation of alternative sets of constraints are being formulated. The economic guidelines call for an objective function that maximizes the present net value of the forest to society.

In application to early plans of National Forests, FORPLAN problems have been immense. Matrix sizes have ranged upward to 5,000 rows and 22,000 columns. The basic role of the FORPLAN system is to generate such matrices and help interpret the resulting optimal solutions.

One major task facing the Forest Service is to implement this FORPLAN system in a comprehensive, consistent, and valid manner. It is already quite apparent that we have major gaps in our knowledge in biological-physical responses, local economic systems, and the cost functions of our organizations.

An aspect of forest planning that FORPLAN does not now handle adequately is the design of transportation systems. Several mixed integer programming systems are under development currently (see King 1980). Whether they will be used to develop transportation alternative subplans for FORPLAN or be integrated into FORPLAN is not known at this time.

The Forest Service has also developed a special input/output model to measure the impacts of each alternative on local and regional economies. It uses a data base that includes a transaction matrix for each of the 3100 local counties in the United States.

Specialized planning in the Forest Service also uses geographical data base systems, timber growth and yield models, ecological interaction models, road design models, pest and fire control and suppression models.

#### Summary

This brief discussion of application of systems analyses in U.S. Forest Service assessments and planning illustrates both the earnestness of our efforts, but also some of the shortcomings of present approaches and work that needs to be done.

Implementation of these systems on an operational basis is proving to be difficult. The systems have to be put on a daily operational basis, with constant attention to even minor defects. Adequate documentation is difficult to prepare and keep up to date. Hundreds of professionals have to be trained on systems analysis principles and on using specific programs. Its a major challenge for the years ahead.

Literature cited

- Adams, Darius M., and Haynes, Richard W. 1979. The 1980 softwood timber assessment market model: structure, projections and policy simulations. (draft). USDA Forest Service, Portland, OR. u.p.
- Ashton, Peter G., Pickens, James G., Ohlander, Coryell, and Benninghop. 1980. Many resources, many uses: a systems analysis approach to renewable resource development. Water Resources Bull. 16(4):738-744.
- Johnson, Norman K., and Jones, Daniel. 1979. FORPLAN: A users guide. USDA Forest Service, Fort Collins, CO. u.p.
- Kirby, Malcolm etal. 1978. ADVENT: A user's guide. 4th Ed. USDA Forest Service, Berkely, CA.
- Kirby, Malcolm W., Wong, Peter, Hager, William A., and Huddleson, May E. 1980. Guide to the integrated resource planning model. USDA Forest Service, Berkeley, CA.
- Larson, Robert W., and Goforth, Marcus H. 1970. TRAS: A computer program for the projection of timber volume. USDA Forest Service, Agric. Handbook. 377, 24 p.
- Marcin, Thomas C. 1972. Projections of demand for housing by type of unit and region. USDA Agric. Handbook. 428, 76 p.
- Navon, Daniel I. 1971. Timber-RAM--a long range planning method for commercial timber lands under multiple-use management. USDA Forest Service. Res. Pap. PSW-70. 22 p.
- Row, Clark. 1977. Balancing supplies and demand. In: Research in Forest Economics and Forest Policy. Resources for the Future, Washington, DC. p. 83-158.
- USDA Forest Service. 1980. An analysis of the Timber Situation in the United States. 1952-2030. (Review draft). USDA Forest Service, Washington, DC. 541 p. and append.
- USDA Forest Service. 1980. An assessment of the forest and range land situation in the United States. USDA Forest Service, Pub. FS-345, Washington, DC. 631 p.

SPATIAL INTEGRITY  
IN FOREST PLANNING MODELS

Dennis P. Dykstra  
Associate Professor of Forestry  
Yale University  
New Haven, Connecticut 06511 USA

Abstract: Accurate forest planning depends largely upon spatial information. Yet many of the more commonly advocated forest planning models either treat spatial data as though they were space-independent or make assumptions regarding spatial relationships which cannot be supported. This paper reviews the need for spatial integrity in four areas: the sizing of forest management units, the definition of management unit shape and contiguity, the recognition of environmental restrictions, and the implementation of temporal (time/space) requirements. A simple model which preserves spatial integrity to some extent and which can be implemented as an extension of many presently existing forest planning models is introduced.

Additional Keywords: mathematical programming, optimization, branch and bound, forest regulation.

Introduction

Forest planning models commonly identify a certain number of hectares to be assigned to each of a set of possible silvicultural systems over some planning horizon. Such models are usually driven by an objective function expressing the desire to find the maximum total volume which can be harvested or the maximum total discounted value which may be realized from the forest over the planning horizon. Because forestry is a science which deals with the management of land areas,

---

Paper prepared for presentation at the workshop, "Forestry: Issues for the Eighties", sponsored by the International Institute for Applied Systems Analysis and held at IIASA headquarters, Laxenburg, Austria, January 8-11, 1980.



accurate forest planning depends largely upon considerations dominated by spatial relationships. This paper is largely a plea that the need for spatial integrity in forest planning models be recognized and incorporated insofar as possible. Toward that end, we will discuss the need for spatial realism in four areas: the sizing of forest management units, the definition of management unit shape and contiguity, the recognition of environmental restrictions, and the implementation of temporal (time/space) requirements. Let us consider each of these in order.

#### Forest Operations and Management Unit Size

As management unit size (area) increases, the per-hectare amortization of fixed management costs over the area is steadily reduced. Planning models often assume that the variable costs of management, such as harvesting and reforestation costs, are constant on a per-hectare basis. If this model is assumed, then the total cost curve is seen as a monotonically nonincreasing curve. Suppose, however, that variable costs increase on a per-hectare basis as management unit size increases. Then the total cost curve has a minimum. Thus, management units can be either too small or too large for efficient operation.

There is good evidence to suggest that unit variable costs do increase with increasing management unit size. As an example, consider the harvesting component. For a small unit in gentle terrain, ground skidding equipment, with low variable costs, may be used. If management unit size is increased, more difficult terrain may be included in the unit, necessitating the use of cable systems and more elaborate road networks, or even the use of helicopters.

By the same token, silvicultural prescriptions can have a significant impact on management unit size. When cable systems are used, for example, operating costs are higher in partial cuts than in clearcuts. At the same time, certain fixed costs, such as those associated with roads and with moving and emplacement of logging equipment, are also higher. This tends to suggest that partial cut units should be somewhat larger than clearcut units in order to permit amortization of these increased fixed costs over an adequate volume of timber.

A recent study by Sessions (1979) investigated the effect of yarding distance, a measure of management unit size, on optimal thinning and regeneration harvest scheduling. Sessions coupled a computer simulation routine to estimate harvesting costs with a dynamic programming optimization routine. The results of Sessions' analysis for average-site Douglas-fir (Pseudotsuga menziesii (Mirb.) Franco) in the Pacific Northwest are summarized in Table 1. For Sessions' study area, as unit size increases, the number of entries into the stand is reduced as is the total volume recovered. Optimal economic rotation in both cases, as judged by the soil rent criterion, was 100 years.

Sessions also showed that total harvesting costs, in dollars per cubic meter recovered, are a joint function of the volume harvested per hectare and the mean diameter of the stand. Virtually all of the forest planning models I have studied in detail, including the large-scale models used by the Forest Service, USDA and by several large companies in the USA, assume no such effect (Johnson and Scheurman 1977).

In some cases, certain other management costs, such as reforestation cost (Table 2) can be significant and may also depend upon unit size. This is especially the case, as shown in Table 2, for hand planting on

Table 1. Management unit size as a determinant of management regime.

EFFECT OF YARDING DISTANCE  
ON OPTIMAL THINNING  
AND REGENERATION HARVEST SCHEDULES

STAND AGE (YEARS)	VOLUME CUT, m <sup>3</sup> /HA	
	AYD=180m (m <sup>3</sup> /HA)	AYD=365m (m <sup>3</sup> /HA)
50	0	0
60	0	0
70	479	0
80	54	540
90	74	0
100	309	322
TOTAL	916	862

(SESSIONS 1979)

units harvested by aerial systems or long-reach cable systems.

If we were to put these cost effects together, we might suggest a silvicultural model similar to the one shown in Figure 1. In this model, areas closer to roads are treated in one way and areas farther away are treated differently. Note the importance of the spatial relationship between the timber and the haul road in this conceptual model.

A final comment I want to make about management unit size concerns multiple forest uses, such as timber and recreation. On public forests

Table 2. Management unit size and planting costs for one region.

DOUGLAS-FIR PLANTING COSTS  
(2-1 STOCK, 1500/HA)

SLOPE %	WALK-IN DISTANCE, m		
	150	450	900
30	135	150	220
60	135	160	235
90	150	175	295

COSTS ARE \$/HA

SOURCE: MAEDERER 1978

especially, recreational-use tracts or other exclusive- or dominant-use areas must normally be segregated, usually both spatially and visually, from management operations. Forest planning models must be structured so that they are capable of such special considerations.

Management Unit Shape

A criterion which, to the best of my knowledge, has only been explicitly considered in one modern forest planning model (Dykstra 1976, Dykstra and Riggs 1977) is that of optimal unit shape, or boundary configuration. Perhaps the most common unit design is the rectangle. It may be used in steep, rugged terrain suited to cable systems, or in more gentle terrain where ground skidding systems are appropriate. It may

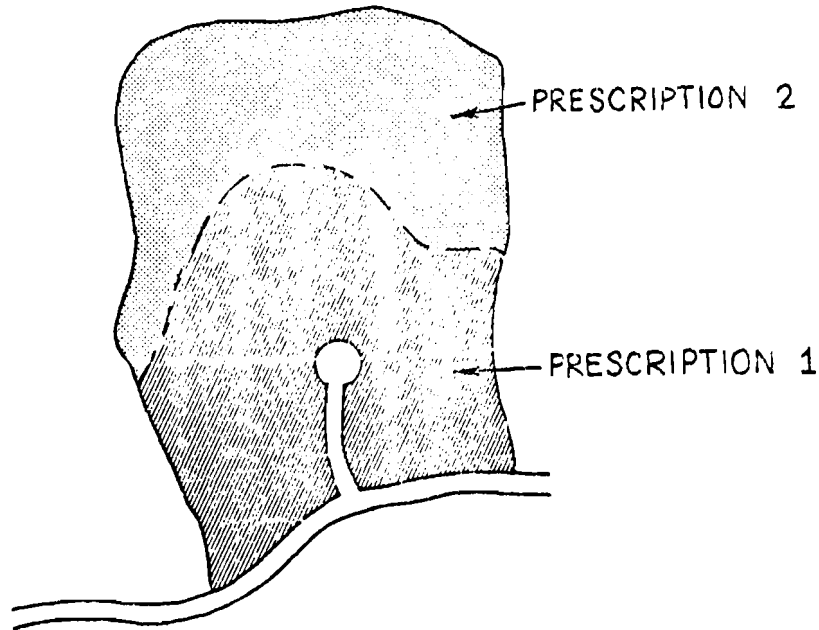

Figure 1. Conceptual model for silvicultural prescriptions which recognizes the spatial dependency of forest management costs.

be used in patch cuttings or in large-scale clearcuttings. Other units are designed by landscape architects to be aesthetically pleasing. Neither type of unit may be close to being economically optimal for the harvesting system used. Consider two nearby management units to be regeneration harvested by cable systems (Figure 2). Though the "natural" shape of a cable unit when the yarder operates from a fixed landing is circular, one may question where the boundary between the units should be placed. One of the important determining factors in this question turns out to be topography, and this has almost never been considered explicitly in forest planning models. Another important consideration is timber type, and especially size and quality of timber relative to

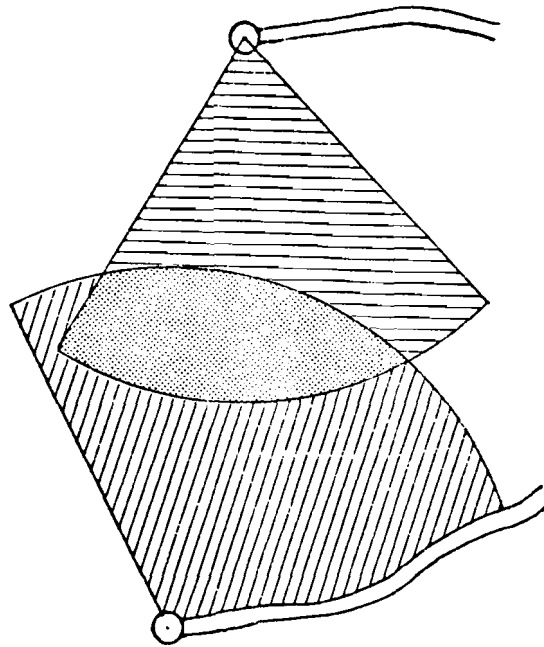

Figure 2. Interaction between adjacent cutting units.

landing location. If all of the large timber is located near one landing, then optimal unit shape will turn out much differently than if the timber is of uniform size and quality. Figure 3 illustrates a case study described in Dykstra and Riggs (1977) for a very steep, heavily timbered Douglas-fir stand in Western Oregon. Note the irregularity of the unit shapes. An interesting corollary to this result is that in uniform timber and terrain, optimal unit configuration tends to be rectangular.

#### Environmental Restrictions

A consideration of emerging importance in essentially all forest planning is that of environmental restrictions. These can have spatial significance, as illustrated in Figure 4. Certain laws, such as the

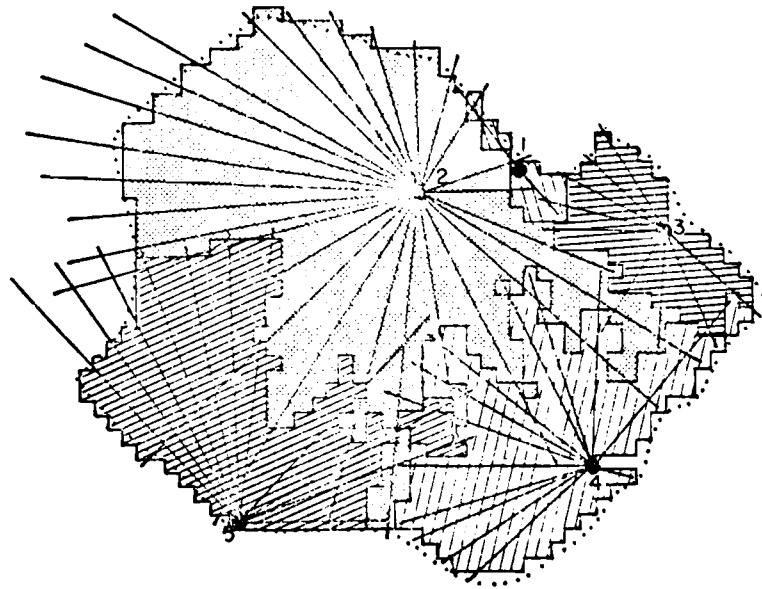

Figure 3. Optimal harvest unit shapes for a case-study planning area in steep, rugged terrain. Numbered sites are landings and radial lines represent cableways.

Oregon Forest Practices Act, and management direction by public agencies have become sophisticated enough to require different levels of operation on various parts of a cutting unit, according to differences in perceived environmental hazards. Practices such as the requirement that stream-side buffer strips of standing timber be left can have an impact not only on harvesting economics but also on unit design. Thus, the modeling of spatial reality can be quite important if the integrity of the entire model, relative to the real system, is to be preserved.

#### Temporal Considerations

The National Forest Management Act of 1976 placed certain limitations on the size of units which may be treated by clearcutting on the National Forests in the USA. The Forest Service has interpreted this

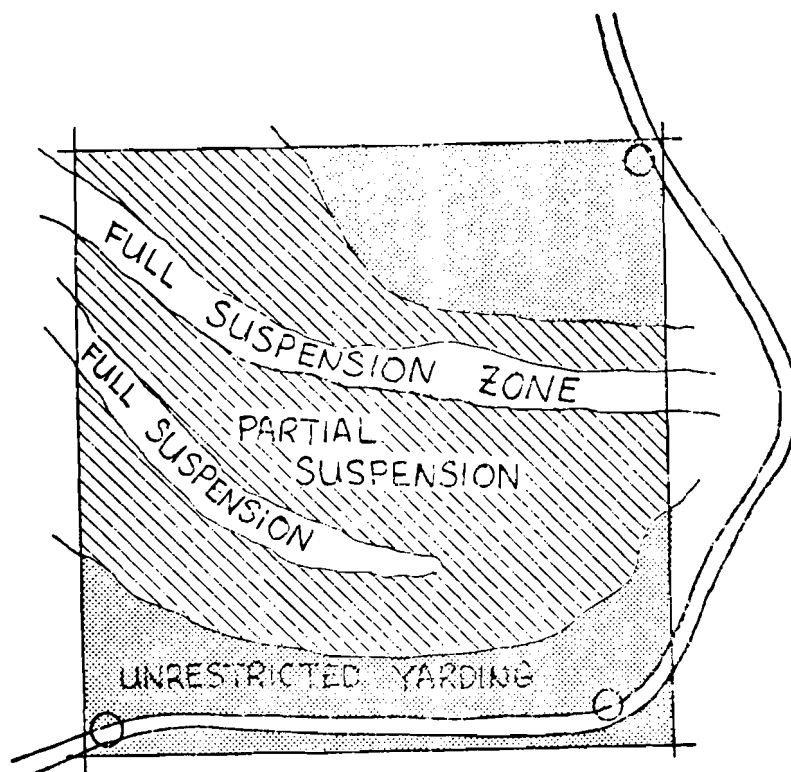

Figure 4. Environmental restrictions on a cable yarding unit.

Full-suspension zones are along major streams; logs must be fully suspended above the stream in those areas. Partial suspension is dictated by environmental hazard.

as including temporal restrictions on harvesting adjacent to existing clearcut units (Knapp 1979). As an illustration, Figure 5 shows a management compartment with 12 management units. Each of these is to be clearcut, one every five years, and at least a decade must elapse between the cutting of any two adjacent units. The units have been ordered to meet this restriction. A recent planning effort on the Six Rivers National Forest in Northern California explicitly recognized this kind of restriction (Walker 1979), although not on a unit-by-unit basis as shown here. Still, the restriction had a definite impact on the harvest prescription for the forest.

Another temporal consideration is that of learning and forgetting



2	10	8
7	4	6
5	1	11
12	9	3

Figure 5. Ordering the cutting units in a management compartment to meet temporal restrictions on harvesting.

by logging crews. Figure 6 shows a "learning curve" for a logging crew studied over a three-year period. At the beginning of the period the crew was assigned to a new cable yarder. The crew's productivity improved markedly at the beginning of the study and continued to improve, though less dramatically, during the entire study period. This result has important consequences for the estimation of harvesting costs. Most cost-estimating procedures presume that crew productivity is a constant, at least in the long run.

Perhaps even more significantly, the study suggested that, on an annual basis, the crew was subject to "forgetting" and had to progress somewhat to attain the productivity of the previous year-end. Figure 7 shows the annual learning curves for the same crew. Each winter the crew was shut out of the woods by heavy snow for two to four months. Start-up the following spring was thus always accompanied by reduced productivity for a time.

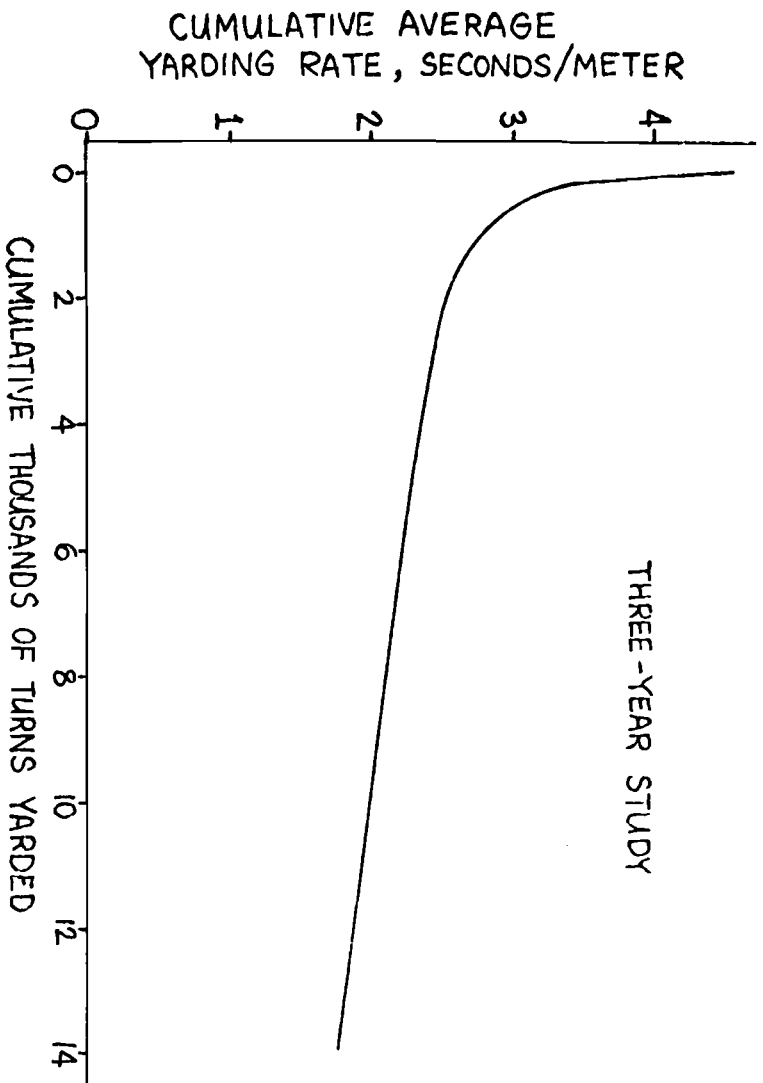

Figure 6. Learning curve for a three-year logging study.

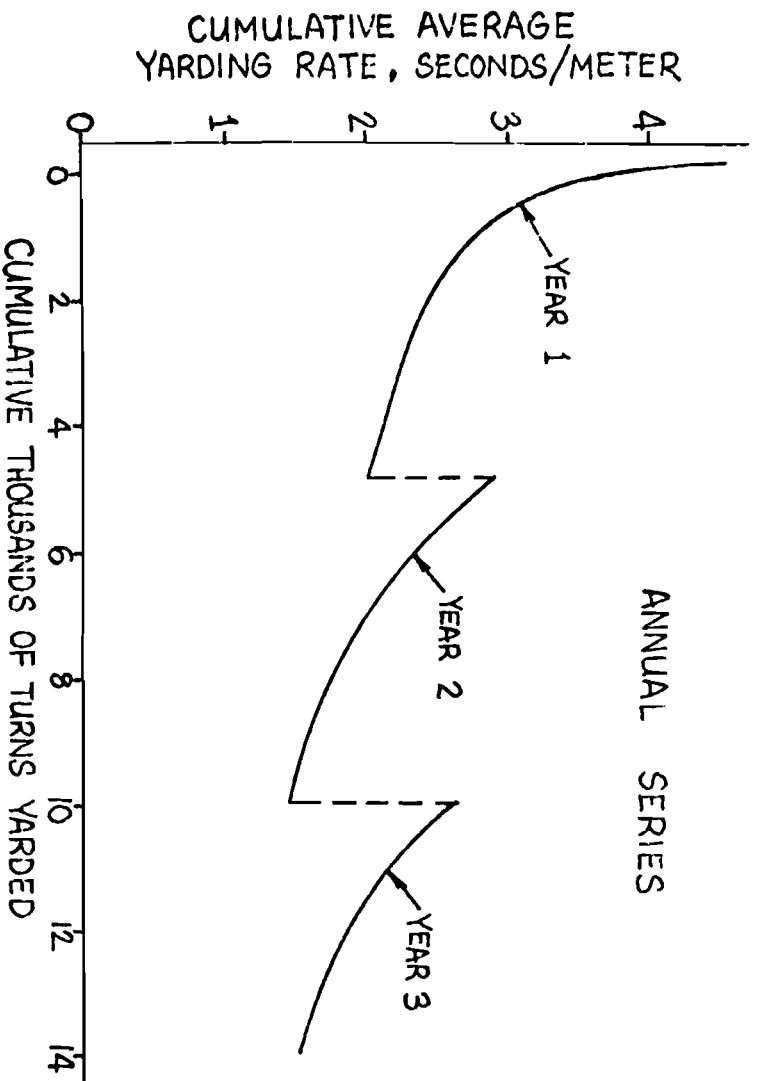

Figure 7. Annual learning curves for the same logging study as in Figure 6.

### Conventional Mathematical Programming Models

We have considered a number of problems related to the spatial integrity of forest planning models. Now let us consider just one of these problems, management unit size, in the context of the conventional forest planning approach. Usually such planning is done, if it is done at all, by implementing one of the linear programming formulations summarized by Johnson and Scheurman (1977). A variant of these formulations, which assumes that the firm or agency faces a downward-sloping demand curve, uses a quadratic, rather than linear, objective function (Walker 1971, Johnson and Scheurman 1977). In either case, however, the mathematical programming model would consider the forests shown in Figures 8A and 8B to be equivalent. That is, management unit area is not explicitly modeled in a spatial sense. This may lead to certain significant problems. Any solution must, of course, be implemented on the ground. There is no inherent trait in the conventional models which would prevent a management prescription being specified for an area of, say, 1 hectare (as in Figure 8B). While it might not be impossible to undertake management activities on a management unit of such small area, it is unlikely that a forest manager would be tempted to do so. Forest managers are generally capable of recognizing economies of scale, even if the planning models do not.

Forest planning models with "built-in" spatial integrity may make some sense in some instances. An example is the "unit planning" approach used in a linear programming mode by Burkhart et al. (1976) and in an integer programming mode by Randall (1972). This approach identifies management units at the outset and then preserves the identity of these units throughout the planning horizon. The question asked by the planning

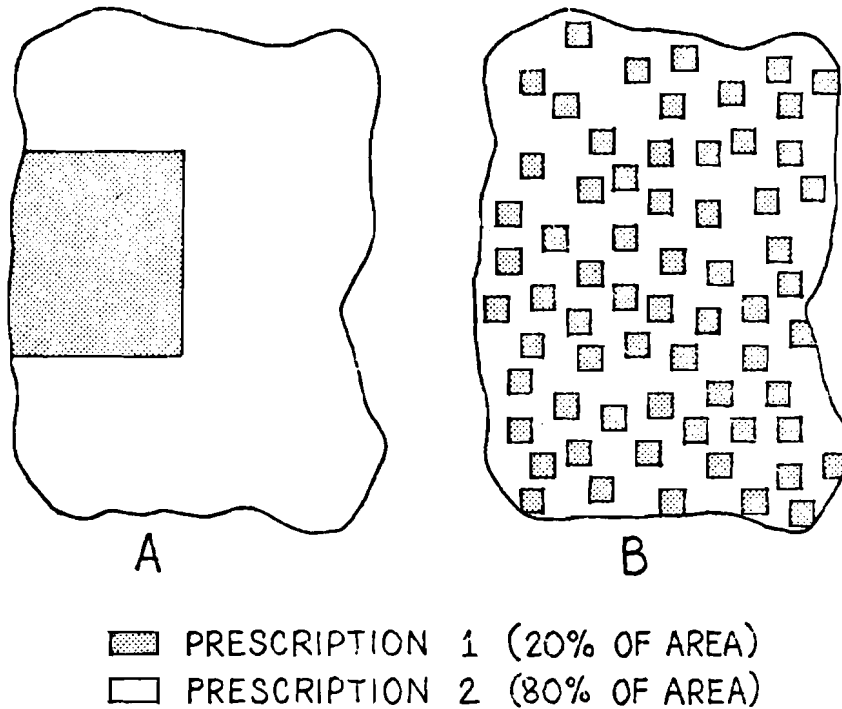

Figure 8. Equivalent mathematical programming representations of a forest area.

model, then, is "what should be the management prescription for each of these planning units?" The disadvantage of this approach is that unit boundaries are treated as constraints, rather than as decisions. Thus, although spatial integrity is guaranteed by this method, "optimality" may be spoken of only in a more restrictive sense.

#### A Simple Spatial Model

An alternative mathematical programming formulation may be derived which is a straightforward extension of the methods discussed by Johnson and Scheurman (1977). Suppose we place restrictions on the feasible area permitted for each type of management prescription. This might be done by utilizing "if...then" constraints. As an example, define  $x_1$  = hectares assigned to management prescription 1 and  $x_2$  =

hectares assigned to management prescription 2. Then, if we decide that the minimum area which can be assigned to prescription 1 is 10 hectares and the minimum area assignable to prescription 2 is 25 hectares, we write

IF  $x_1 > 0$ , THEN  $x_1 \geq 10$

IF  $x_2 > 0$ , THEN  $x_2 \geq 25$

These constraints permit  $x_1$  and  $x_2$  to equal 0, but if they are set to any greater quantity, then the minimum limits apply.

There are two difficulties with this simple spatial model, although it can be used to adequately reflect minimum (and maximum) management unit areas. First, it adds to the number of constraints in the mathematical programming model. Even worse, though, the constraints are discontinuous. It is possible to convert the problem to an equivalent 0-1 programming problem which can treat these discontinuities (Watters 1967, Wagner 1969). The cost of the transformation, however, is that the number of decision variables and constraints is greatly increased. And, of course, we then have a 0-1 programming problem to solve, rather than a linear programming problem.

An alternative solution technique which can be used with the linear programming algorithm is illustrated for a forest of 26 hectares and the two "if...then" constraints above in Figure 9. This technique is a variant of the "branch and bound" technique developed by Land and Doig (1960) for solving integer programming problems. The methodology proceeds by first solving an unconstrained problem (i.e., without the "if...then" constraints). The optimal value of  $x_1$  for this solution (node 1) is acceptable (more than 10 ha), but the optimal value of  $x_2$  is less than the minimum feasible area of 25 ha. Thus, we "branch" on

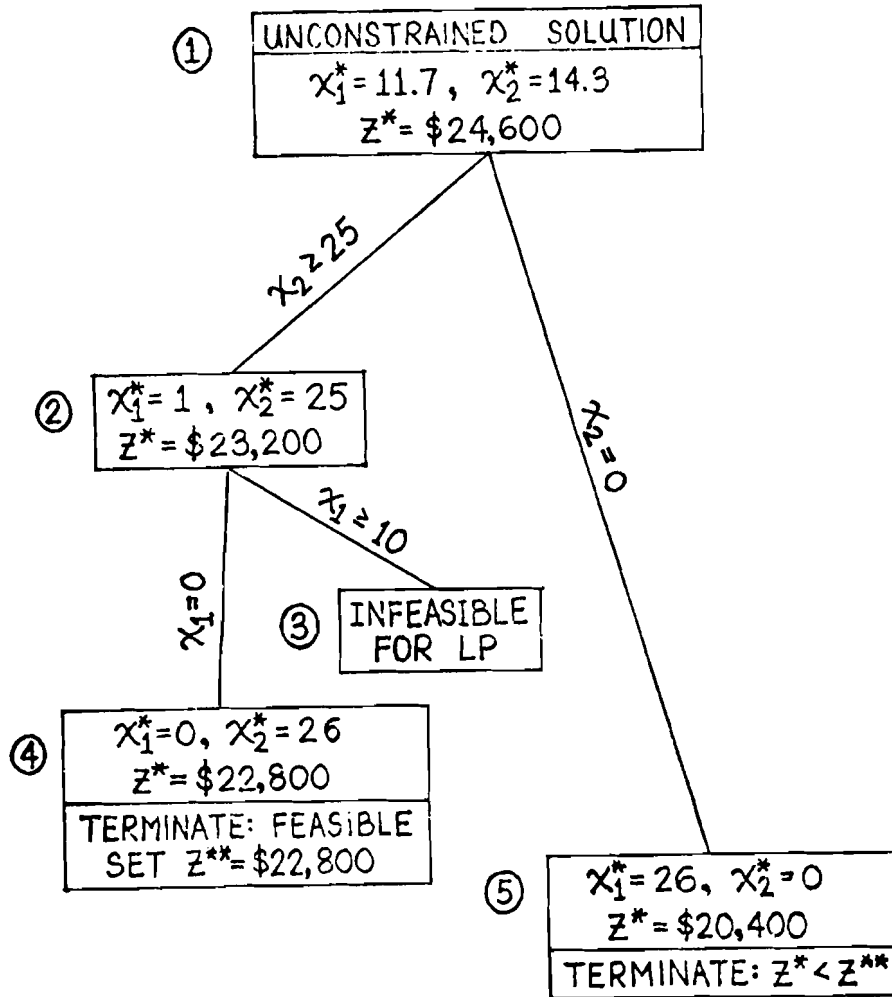

Figure 9. Branch-and-bound solution procedure for the problem with "if...then" constraints.

variable  $x_2$ , setting up two candidate sub-problems at nodes 2 and 5. The problem at node 2 is the "unconstrained" problem plus the constraint  $x_2 \geq 25$ ; the problem at node 2 is the "unconstrained" problem plus the contradictory constraint  $x_2 = 0$ .

Solving at node 2, we find that we now meet the constraint on  $x_2$  but we no longer meet the constraint on  $x_1$ . Thus we form contradictory branches on  $x_1$  at nodes 3 and 4. The problem at node 3, however, is infeasible because it would require that  $x_1 + x_2$  be greater than 26, our area limit. The problem at node 4, on the other hand, is fully feasible

for the original problem including the "if...then" constraints. Thus we terminate this branch and save the value of the objective function at node 4 as  $z^{**}$ .

Although we have found a feasible solution, we have not yet determined that it is the optimal solution. To do this, we must consider the one possibility not yet considered: that it is "better" to have  $x_2 = 0$  than to have  $x_2 \geq 25$ . And, as the solution at node 5 shows, it is clearly not better to do so, thus proving that the optimal solution is the one at node 4.

The major disadvantage of this solution method is that it may add slightly or significantly to the computer time required to come to a feasible solution. The advantage is that it provides a solution more in line with the realities of forest management. Thus far I have done very little testing with this approach, although I plan to do more in the near future. Actual experience with the solution procedure, in the context of real-life forest planning situations, will provide a series of benchmarks which can be used to determine whether the additional computational and analytical time required for this procedure provides sufficient additional spatial integrity to make the effort worthwhile.

#### Literature Cited

BURKHART, H. E., W. A. LEUSCHNER, R. D. STUCK, J. R. PORTER, and M. R. REYNOLDS. 1976. Aids for Unit Planning on the Appalachian National Forests. Division of Forestry and Wildlife Resources, Virginia Polytechnic Institute and State University. Publication No. FWS-1-76, 20 p.

- DYKSTRA, D. P. 1976. Timber Harvest Layout by Mathematical and Heuristic Programming. Ph.D. Diss., Oregon State University, Corvallis. Diss. Abstracts International 37(4), microfilm no. 76-23510.
- DYKSTRA, D. P., and J. L. RIGGS. 1977. An Application of Facilities Location Theory to the Design of Forest Harvesting Areas. American Institute of Industrial Engineers Transactions 9(3):270-277.
- JOHNSON, K. N., and H. L. SCHEURMAN. 1977. Techniques for Prescribing Optimal Timber Harvest and Investment Under Different Objectives -- Discussion and Synthesis. Forest Science Monograph 18, 31 p.
- KNAPP, W. 1979. Silviculturist, Region 6, Forest Service, U. S. Department of Agriculture, Portland, Oregon. Personal communication.
- LAND, A. H., and A. G. DOIG. 1960. An Automatic Method of Solving Discrete Programming Problems. Econometrica 28:497-520.
- MAEDERER, B. 1978. Hodads Tree Planting Cooperative, Eugene, Oregon. Cited in: Sessions 1979 (see below).
- RANDALL, R. M. 1972. An Operations Research Approach to Douglas-fir Thinning. Forest Service, Pacific Northwest Forest and Range Experiment Station, Portland, Oregon. Research Paper PNW-148, 23 p.
- SESSIONS, J. 1979. Effects of Harvesting Technology Upon Optimal Stocking Regimes of Forest Stands in Mountainous Terrain. Ph.D. Diss., Oregon State University, Corvallis.
- WAGNER, H. M. 1969. Principles of Operations Research. Prentice-Hall, Englewood Cliffs, New Jersey. 937 p. + appendices.
- WALKER, J. L. 1971. An Economic Model for Optimizing the Rate of Timber Harvesting. Ph.D. Diss., University of Washington, Seattle. Diss. Abstracts International 32(5):2276-A (microfilm no. 71-28489).



WALKER, J. L. 1979. The Six Rivers National Forest Timber Harvest Scheduling Study. Mimeo No. 9153, Western Timber Association, San Francisco, California. 5 p.

WATTERS, L. J. 1967. Reduction of Integer Polynomial Programming Problems to Zero-One Linear Programming Problems. Operations Research 15:1171-1174.

Modeling Timber Supply from Private Nonindustrial Forests

Clark S. Binkley

The management of private forest lands has traditionally been a matter of serious social concern. Once timber prices rise to a level where investments in forestry can be justified on the same grounds as other business investments, the forest products industry typically responds with intensified timber culture on their land holdings. Although external effects (water and air pollution from land management activities, for example) continue to warrant public attention, the level of timber production responds to ordinary economic signals.

No such confidence can be found in the actions of the private nonindustrial forest owners. The broad official definition of these holdings includes forest lands held by individuals or corporations who do not also own the requisite equipment to convert logs into lumber, pulp or other secondary forest products. In the United States these ownerships range in size from one acre to over one million acres; about one third of the Boston metropolitan area would be officially classified as private nonindustrial forest land.

This paper is concerned with modeling the behavior of these landowners in order to predict the amount of timber which would be supplied from these lands under specified future conditions. But timber is not the only valuable output from these forests. Nontimber forest products--recreation, wildlife and aesthetically pleasing views--may in fact be more valuable than the timber outputs. Arguing for increased timber production on these lands rests on the judgment that the value of the additional timber exceeds the value of the nontimber outputs which must be foregone to obtain the additional timber supply. This seems to remain an open question.

With the limited scope of this paper firmly in mind, we will consider the problem of modelling timber supply from these lands in four parts. First, the private nonindustrial forestry situation in the United States is briefly explained. In that context, a model of landowner behavior is postulated. This disaggregate supply model extends the conventional theory of profit maximization to include consideration of the nontimber values produced for the landowner by his forest holding. The third section tests statistically this model on a sample of forest landowners in New Hampshire. The final section summarizes the conclusions of the analysis and suggests several avenues for further research on this problem.

#### THE SITUATION IN THE UNITED STATES

Private nonindustrial forests occupy almost three fifths of the commercial forest land in the United States, or roughly 15% of the nation's coterminous land area. In 1970 about 45% of the country's domestic roundwood supply was harvested from these lands. These circumstances lend easy credence to the widespread official and professional concern over the management of these forests. The private nonindustrial forest situation in the United States can be defined in four dimensions: their contribution to the total forest land base, their ownership, the timber supplies from them and the status of the growing stock residing on them.

The Land Base. Table 1 shows the status of commercial forest lands in the United States over the twenty-five years between 1952 and 1977. Before considering these data, note that the precise official definition of "commercial forest land" is somewhat different from the ordinary usage of those terms. Commercial forest land is (USDA, 1973, Appendix III):

- i. ten percent occupied by forest trees of any size or formerly having such cover,
- ii. not developed for nonforest use nor withdrawn administratively from timber production,
- iii. capable of producing  $20 \text{ ft}^3/\text{acre}/\text{year}$  ( $1.4 \text{ m}^3/\text{ha}$ ) of industrial roundwood in natural stands,
- iv. found in parcel sizes of one acre or greater.

Consequently, timber production is probably uneconomic on much of this land. The following figures overstate to some unknown degree the actual land base for timber production in the United States.

Table 1 shows that commercial forest land has been roughly constant over the period, equaling about 500 million acres. There has been a slight decline in public ownership which is likely to continue as more land is set aside for wilderness uses. Most of the publicly owned forest land is held in the national forests, but significant timber producing areas are held by other federal agencies (Bureau of Land Management, Indian reservations, the Department of Defense) and by the state governments.

Private ownership of commercial forest land remained almost constant over the period. Ownership of timberlands by the forest products industry (those companies with the requisite plant and equipment to convert logs into lumber, pulp and other secondary forest products) grew by almost 10 million acres in the past twenty-five years. In aggregate the nonindustrial lands, which collectively comprise the majority of commercial forest land in the U.S., changed little in this period. It is these lands where the official and ordinary definitions of "commercial forest land" diverge to the greatest degree, and here is also the focus of this paper's attention.

Table 2 presents a more detailed analysis of the ownership of these lands. By official definition farms must gain a small amount of income from agricultural products (\$50 for places of 10 acres or greater; \$250 for places of less than 10 acres). There are two sources for statistics on farm forest ownership: the Forest Service data reported in Table 2 and the decennial Census of Agriculture. Although they use the same definition of a "Farm", in 1970 the Census of Agriculture found some 19 million acres less forest land than did the Forest Service. The discrepancy probably relates to differences in definitions of "forest land" in the two surveys, but the precise source of the discrepancy has never been identified.

Miscellaneous private owners are all the private nonindustrial forest owners who do not qualify as farmers. As a residual category they display a wide diversity of socioeconomic characteristics and forest ownership objectives. They are located in every region of the country, but concentrated in the east.

While the total area held by the private nonindustrial owners as a group has not changed significantly between 1952 and 1977, the composition of ownership within this class has shifted in a major way. Miscellaneous owners now comprise a majority of the class, and hold one third the nation's commercial forest land. Farm ownership has declined at a rate of about 1.6% annually.

Existing data do not permit any further national level analysis of the forest land ownership patterns. The last comprehensive survey of forest land ownerships was completed in the late 1940s and even that survey assessed little more than the size of the holding. The next section provides some more detailed information on the private nonindustrial holdings in the New England region.

Owners in New England. New England is a small, heavily populated (by U.S. standards) region located in the northeastern corner of the country. The nation's forest products industry had its roots there (the first sawmill in the country was established in the early 1600s in Maine). Since then the locus of the forest products industry has shifted to the south and west leaving this region a legacy of significant nonindustrial private land ownership.

Table 3 shows the shift in the kind of owner who holds these lands. The 1948 and 1973 data are not precisely comparable, as the former were derived from complete surveys of 23 towns in the region and the latter from a random sample of owners throughout the region. We see a significant increase in the number of business and professional ownership of forest land, coupled with a decline in the number of farm ownerships. The trends in numbers of owners are roughly paralleled by the trends in the area held, although the decline in farm ownership is not as pronounced as the decline in their numbers. Thus primarily the farms with small woodlots left farm ownership during this period.

At the same time that farm ownership of forest lands is declining, the importance of the remaining forest lands to farmers is also diminishing. This can be seen in the data developed for Vermont which is shown in Figure 1. In real terms, both the total sales of forest products from farms and the sales per acre of forest land declined substantially over the past eight decades. Where the sales amounted to about \$7.00 per acre in 1900, they are only about \$1.00 per acre in 1970. The recent increases in demand for fuelwood has probably reversed this steady downward trend, but it is unlikely that forest products will regain the relative position in farm income they held prior to World War II.

Concomitant to the shifts in the kinds of forest land owners in New England has been a significant decline in the size of the holdings. A partial picture of this trend can be seen in Table 4 which shows the decline in the median size of holding between 1945 and 1973 for five New England states. These data are not precisely comparable because the 1945 data refer to only those holdings of less than 5000 acres (2000 ha) and the 1973 data include all holdings. Consequently, the 1945 data underestimate the actual median size of holding by some unknown amount. Because there are very few holdings larger than 5000 acres in this region, the magnitude of the underestimate is likely to be quite small. Kingsley (1979) and Gould (1979) discuss further the discrepancies between these data. In all five states the decline in the median size of holding over the 28 year period has been marked, ranging from a high of 84.4% in New Hampshire to a low of 67.1% in Vermont. As we will see below, this decline in parcel size has significant implications for timber supply from private nonindustrial forests.



Domestic Timber Supply. In 1970 43.6% of the roundwood domestic supply was harvested from private nonindustrial forests as Table 5 shows. According to recent estimates by the Forest Service, this fraction is expected to increase to 54.8% by 2000. Total output from the nation's forest will increase, according to this forecast, by 5.2 million cubic feet and over four fifths of this increase will come from the private nonindustrial forests. The role of the private nonindustrial lands to timber supply is large and growing.

Status of Growing Stock. Consider this prognosis in light of the data in Table 6. Private nonindustrial lands, in gross terms, appear to be in poor condition to meet these new timber demands. Clawson (1979) has shown that regional differences in forest land ownership account for much of the difference in these gross measures of forest condition. Furthermore, it is difficult to interpret these data without some knowledge of the age distributions of the stands involved. But in any case, the current situation on private nonindustrial land does not warrant gilded optimism that the Forest Service timber supply projections can be met without increased investment in timber production on those lands.

In sum, what many have called the private nonindustrial forest problem in the United States can be characterized in three parts. These lands comprise a majority of the timber production base, defined by the broad official definition of commercial forest land. They contribute a significant fraction of the nation's domestic roundwood production, and their contribution is forecast to increase in the next two decades. But the condition of their forests is perceived to be poor, and traditional levels of investment in timber production will not call forth the needed timber. Added to these circumstances is a decline in farm ownership of forest land, and as we will

see below, farmers are being more responsive to market incentives than are the nonfarm private nonindustrial owners. The average parcel size of forest land also appears to be declining. If there are scale economies to timber production and harvesting, this apparent trend also bodes poorly for the timber supply from these lands. Despite the importance of timber supply from private nonindustrial forests, little success has been achieved in modeling in quantitative terms the supply behavior of this class of owners. The next two sections turn to this problem.

#### A MODEL OF LANDOWNER BEHAVIOR

Nonindustrial private forest owners are known to hold their land for reasons which transcend maximization of either short term profit or present value asset position. The most simple model which captures the nonpecuniary values of forest lands characterizes the forest holding both as a productive enterprise and as a consumptive good in itself. The aspects of a productive enterprise occur because through timber sales the forest is capable of producing income which can be used for the owner's consumption of goods and services. Forest land is also a consumption good because it can produce direct utility to the owner through recreation, solitude, aesthetic pleasure, or other amenity values. In deciding how much timber to sell, the owner balances the value of the consumption made possible by the income derived from a timber sale against the amenity values lost by harvesting that timber.

Suppose that a forest landowner derives utility from the consumption of nontimber land outputs, (e.g. recreation, aesthetic amenities) and all other consumption. He makes timber harvest decisions as though he were maximizing a utility function subject to two constraints. First, his total outlay cannot exceed his income which equals an amount exogenous to the model plus his

receipts from timber sales and less his cost of holding land. Second, the combinations of timber and nontimber outputs are limited to those which are technically feasible given his initial endowment of land. In symbols, the problem

$$\max_t u(r, y) \quad (1)$$

subject to

$$y = y^e + p^t t - cl \quad (2)$$

$$r = g(t, \ell) \quad (3)$$

where

$u(r, y)$  = a utility function defined over  $r$  and  $y$

$y$  = net income available for consumption of nonland goods

$y^e$  = income exogenous to the model

$p^t$  = price of timber (stumpage price)

$t$  = amount of timber cut

$c$  = per acre cost of holding land

$\ell$  = amount of land held

$r$  = nontimber land outputs and consumption

$g(t, \ell)$  = a function relating timber to nontimber land outputs.

At the outset, the limitations of this model should be noted. First, equation 3 reflects the essential economic aspects of the forester's doctrine of multiple use applied to the individual ownership. This relationship is notoriously difficult to estimate and the model simply postulates its existence. Second, the only income producing output from the forest land is timber. No grazing or maple operations, for example, are assumed to take place. However, as long as these activities can be considered only to affect the exogenous income  $y^e$ , and not the level of amenity outputs from the land, the model adequately

accounts for them. Third, speculative gains associated with land ownership are not explicitly considered in the model. If current timber operations do not affect the perception of these gains, then this exclusion is not troublesome. Since in this model the land endowment is fixed, such speculative gains would enter primarily through the costs of holding land  $c$ , and can be treated as simply a parameter of the model. Fourth, initially the land endowment is fixed and the only decision to be made is the amount of timber to cut. Binkley (1979) relaxes this assumption to consider the timber and land markets simultaneously. In a similar vein, the model is static: it considers only how much timber is cut and not how much is reinvested in timber management.

Holding the parcel size constant, the solution of this simple optimization problem can be found by substituting the constraints into the objective function, differentiating the result with respect to  $t$ , setting this derivative to zero, and solving the resulting equation. This procedure gives the optimizing condition as

$$u_y p^t = -u_r g_t \quad (4)$$

where the subscripts are used to denote partial differentiation with respect to the subscript variable. At the optimum, the marginal value from an additional unit of timber production equals the marginal value of the nontimber outputs which must be foregone to obtain that unit.

This indirect supply equation can be examined in conjunction with the assumed functional shapes (i.e. signs of the first and second derivatives of  $u$  and  $g$ ) to ascertain the response of the owner to changes in the variables of the model. Binkley (1979) gives the details of the calculations, and the results are presented below:

<u>Variable</u>	<u>Sign of affect of timber supply</u>
$p^t$	+/-
$y^e$	-
$c$	+
$l$	+

The ambiguous sign of the price variable occurs because an increase in price will lead to increased timber outputs only if the income gained from that increase more than offsets the utility losses associated with the reduction in nontimber production. The sign of the price effect is likely to depend on the income of the owner. The effect of exogenous income is as would be expected, given diminishing marginal utility of income. Increases in the costs of holding land are tantamount to decreases in exogenous income, so they naturally lead to increases in timber harvest. Thus raising property taxes, may, in the short run, be an effective way to increase timber outputs although the long run effects might be to shift land out of timber production and consequently reduce timber supply. In this model increasing parcel size leads to increases in timber harvest through the same effect--larger owners are more "land poor." These theoretical expectations are generally confirmed in the empirical work reported below.

#### AN EMPIRICAL APPLICATION OF THE MODEL

The desiderata for estimating this timber supply model are data on the amount of timber offered by an individual (say, annually), the stumpage price associated with the amounts offered, owner and ownership characteristics, and information on the technical tradeoffs between timber and nontimber outputs. Unfortunately data directly in this form are not generally available and existing data were adapted for the purposes of this research. The recent survey

of forest land owners in New Hampshire (Kingsley and Birch, 1976) provided data on owner and ownership characteristics and timber harvest behavior. These were combined with stumpage price data to form the basis for the statistical estimates of the timber supply model.

The major limitations of the data used to estimate the model are four. First, the supply variable is dichotomous, indicating only whether or not an owner harvested timber in a specified year and not how much timber was actually cut. This type of dependent variable leads to a "stochastic utility" model of choice, pioneered by McFadden (1973) to estimate the split of transportation demand between modes. With a specific assumption about the distribution of errors in the utility function (that they are Weibull), maximum likelihood logit is the relevant estimator for the supply equation, and that procedure is used below. Second, because the technical tradeoffs between timber and nontimber outputs are not explicitly known, the models presented below are subject to some unknown specification error. Third, the survey used in this study did not determine the price offered at the time of the sale nor the prices previously refused, both of which are needed to estimate the model. As surrogates, county-wide annual average price indices for the major forest products sold in the county of the respondent were used. This leads to the well-known errors-in-variables problem, and biases the statistical significance of the price coefficient towards zero. Finally, because the income of the respondent was known only for the survey per year (1973), it was necessary to work from a strong permanent income hypothesis, and use variables such as age and education to help provide a better measure of the permanent income. Table 7 summarizes the variables used in the model and the hypothesized relationship to the probability of harvest.

Table 8 reports the logit results. The tables report the estimated coefficient, asymptotic t-values and the elasticity computed at the mean of the independent variables. The chi square statistic ( $\chi^2$ ) tests the hypothesis that all of the coefficients except the constant are zero. The statistic corresponds conceptually to the F-statistic in ordinary least squares regression. The effect of each of the variables is discussed separately and then the difference in timber harvest behavior between farmers and nonfarmers is analyzed.

Price. First, note that the price variables all have positive signs. This is consistent with the normal relationship expected for timber supply and suggests that in the sample as a whole each respondent is operating at a point in his utility function where the added income from additional harvest outweighs the losses in amenity values.

Second, the statistical performance of the nominal price indices is superior to that of their real counterparts. Theory would suggest the opposite result. There may be a lag in the perception of inflation. That is, the landowner establishes in his mind what he considers to be a "good" price for stumpage in the absence of inflationary effects. He then sells if that price is reached or exceeded, irrespective of the real price at the time of the sale.

Third, the sawtimber price index is statistically the best of the four indices. Sawtimber removals were from 65% to 77% of all removals statewide during the study period. In the New Hampshire ownership survey, which is the basis for these results, 68% of the owners harvested sawlogs alone where only 4% cut pulpwood alone (Kingsley and Birch, Table 18, p. 43). As a consequence, the sawtimber price index probably more closely reflects the price of the products most commonly sold than does the composite timber price index.

Area. The results confirm the hypothesis that larger ownerships are more likely to be harvested than are smaller ownerships. Preliminary analysis indicated that the logarithmic specification of the area variable was superior to the linear one so  $\ln(\text{AREA})$  was retained throughout these results.

Using the AREA as an explanatory variable is subject to a type of identification problem: does the area effect enter the problem from the supply side as hypothesized here or through the demand side? If logging is more attractive on larger tracts, then it is possible that part of the effect measured in this analysis results from the demand side rather than any part of the landowner choice process. Under this hypothesis, larger holdings would command a higher stumpage price. Then area serves as a proxy for the price faced by the landowner while the price variable measures the aggregate trends.

Income, Age, and Education. Given the available data, it was necessary to use a strong permanent income assumption in order to measure income at the time of harvest. Age and education can be considered proxies which improve the measurement of permanent income. Consequently those variables are considered here along with income itself.

Recall that income was measured for 1973 only, so assumptions were needed both to develop a continuous measure and to estimate income in the years prior to the survey. Real income refers to the assumption that the respondent's real income remained unchanged throughout the period 1947-1973, and nominal income refers to the assumption that his nominal income was constant throughout the study period.

Nominal income enters the model with the expected negative sign in all cases. In all samples the statistical performance of the nominal income variable is superior to that of the real income variable. This result lends some credence to the "lag in the perception of inflation" hypothesis advanced above.



Age is significantly positively associated with the probability of harvest indicating that older owners are more likely to harvest timber than are younger ones. This result may simply be due to age proxying for income, but another hypothesis was suggested by the interviews with nonindustrial private woodland owners. Investment in timber growing stock marks the early years of a landowner's life. This growing stock provides amenity values as well as a hedge against financial hardship. As the landowner grows older, his financial planning horizon shortens, and therefore the expected value of the timber assets as a hedge against uncertainty diminishes. He then is more likely to liquidate his growing stock, irrespective of his nontimber income.

Education, the number of years of formal school attendance, is not strongly associated with the propensity to harvest timber. In part this may be due to collinearity between income and education in the sample. Again this result suggests that education is needed to measure permanent income with the data used in this study.

Farm versus Nonfarm Ownership. Farm ownership of private nonindustrial forest lands is declining. Consequently it is of some interest to explore the differences in the determinants of timber harvest behavior between farmers and nonfarmers. Because farming is a business enterprise, we might expect farmers to reveal a greater sensitivity to price than nonfarmers.

Table 9 reports the results of analyzing the farm and nonfarm subsamples separately. First, observe that both groups display a strong price response, but the elasticity for farmers is nearly twice that for nonfarm owners. Second, the other variables used in this analysis (forested area held, income and age) are not significantly related to farmer harvest decisions.

Compared to the sample of private nonindustrial owners as a whole, nonfarmers show somewhat different responses to the independent variables. Sensitivity to price and to the size of holding is slightly less for nonfarmers than for the full sample. Nonfarmers are slightly more responsive to income and to age than is the sample as a whole (compare Table 7 with Table 8 to see these differences).

The overall differences in the relationship between the independent variables and the probability of harvest between the two groups can be tested statistically. The test is based on the difference between the value of the log likelihood function for the full sample and the sum of the log likelihood function values for the two subsamples. Twice this difference is known to have a chi square distribution (Theil, 1971, pp. 396-397) under the null hypothesis that there is no difference between the two groups. This test is analogous to the so-called Chow test in ordinary least squares regression. This test indicates that the model's coefficients collectively differ between farmers and nonfarmers (chi square = 8.13, 1 degree of freedom). In addition to statistical significance, this classification has practical importance. The predicted probability of timber harvest at the mean of the independent variables is .0339 for farmers and .0270 for nonfarmers, a difference of 25.6%.

#### CONCLUSIONS AND FURTHER RESEARCH

The postulated model of landowners' behavior with respect to short term timber supply seems to accord with observed behavior. The statistical estimates of the model's coefficients conform to the theoretical expectations. Price affects the propensity to harvest timber. Higher incomes are associated with lower levels of timber production. Smaller parcel sizes lead to a lower probability of timber harvest. Farmers are more likely to harvest timber than are nonfarmers, and farmers are more responsive to price.

Stumpage price is endogenous to the timber market but the latter three variables are not. In the United States trends are towards higher rural incomes, smaller parcel sizes and less farm forest land ownership. Consequently, all else equal, timber supply from private lands will decline unless prices rise to compensate for the trends in these other variables. In short, the supply curve is shifting inward so increased prices will be necessary just to keep output constant.

Interpreted another way the problem of timber supply from private non-industrial forests cannot be divorced from larger questions of rural land policy. Raising rural incomes is a traditional objective of public policy. The activities of farmers respond, in part, to agricultural policy and price support systems. Conversion of farms to nonfarm ownership and the parcelization of rural lands are land use issues which transcend the problem of timber production. Perhaps greater success in dealing with the nonindustrial forestry problem would be achieved by placing the question in this larger context.

The construction and performance of this model suggests several avenues for further research. The first and most obvious is to collect data more suitable to a disaggregate supply model. At this time such data are lacking. Major landowner survey efforts are being conducted in the United States without any clear theoretical basis for constructing supply models from the resulting data. Modest redirection of these efforts could yield significant analytical benefits.

Second, the size of holding can be entered in the model as a decision variable rather than an initial endowment. This leads to a simultaneous model of land and timber markets. Binkley (1979) has examined the theoretical aspects of this extension, but did not attempt to estimate the model empirically. Such

an approach might explain some of the apparent economic anomalies sometimes observed in rural land markets. It also might be the basis for more reasonable forecasts of trends in forest land use. At present the Forest Service projects the land base for timber production as a linear extrapolation of past trends. Thus we find the apparent contradiction of a shrinking land base for timber production at the same time stumpage prices are projected to rise rapidly.

Finally, the dynamic aspects of the timber harvest decision need to be incorporated into the analysis. This would include timber inventory change, investment in timber production and other capital assets, and the preferences for present over future consumption. As stumpage prices rise, increased investment in timber production would be expected. The resulting increase in timber supply would be expected to moderate future stumpage price increases and some equilibrium price level would be approached. This adjustment process depends on the investment response of the forest owner to the higher prices. Where the objective of ownership is not solely pecuniary, the operation of this adjustment process is not straightforward.

Literature Cited

- Barraclough, Solon L. 1949. Forest land ownership in New England. unpublished PhD thesis, Department of Economics, Harvard University.
- Binkley, Clark S. 1979. Timber supply from private nonindustrial forests: an economic analysis of landowners behavior. unpublished PhD thesis, Department of Forestry and Environmental Studies, Yale University.
- Clawson, Marion. 1979. The economics of U.S. private nonindustrial forests. Resources for the Future working paper R-14.
- Gould, Ernest M. 1979. SNIPO's: how numerous. Journal of Forestry 77:134, 200.
- Kingsley, Neal P. 1979. SNIPO's: how numerous? Journal of Forestry 77:134.
- \_\_\_\_\_. 1976. The forest-land owners of southern New England. USDA Forest Service Resource Bulletin NE-41.
- \_\_\_\_\_ and Thomas W. Birch. 1977. The forest-land owners of New Hampshire and Vermont. USDA Forest Service Resource Bulletin NE-51.
- McFadden, D. 1973. Conditional logit analysis of qualitative choice behavior. in P. Zarembka, ed. Frontiers of Econometrics, (Academic Press: New York).
- United States Dept. of Agriculture (USDA). 1978. Forest statistics of the U. S., 1977. (GPO: Washington, D.C.)
- \_\_\_\_\_. 1973. The outlook for timber. (GPO: Washington, D.C.)

TABLE 1  
Commercial Forest Land in the United States  
(million acres)

	1952	1962	1970	1977	% 1977	Change, 1952-1977 %/Year
Total	500.1	511.0	500.3	487.7		-0.1
Public	144.8	145.1	143.0	136.6	28.0	-0.2
National Forest	94.7	96.9	94.7	89.0	18.2	-0.2
State	20.0	20.8	23.5	23.6	4.8	+0.7
Private	355.4	366.0	357.4	351.1	72.0	-0.05
Industry	59.6	61.6	67.0	68.0	13.9	+0.5
Nonindustrial	295.8	304.4	290.4	283.1	58.0	-0.2

Source: USDA (1978) Table 2, p. 8

TABLE 2

Private Nonindustrial Commercial Forest Land in the United States

	1952	1962	1970	1977	Change, 1952-1977 %/year
Farm	173.0	145.0	125.0	116.8	-1.6
Miscellaneous Private	122.8	159.4	165.4	166.4	+1.2

Source: USDA (1978) Table 2, p. 8.

TABLE 3

Percentage Distribution of New England Private Nonindustrial  
Forest Land Ownership, 1948 and 1973

Type of Owner	Numbers of Owners		Acreage Owned	
	1948*	1973**	1948*	1973**
Business/Professional	21.5	44.5	26.7	48.0
Blue Collared	21.0	25.6	12.1	11.4
Retired	12.0	15.2	13.8	20.9
Other	23.3	10.2	30.5	7.0
Nonfarm	77.8	95.5	83.1	87.3
Farmers	22.2	4.5	16.8	12.6 <sup>+</sup>

Source: Derived from

\*Barraclough and Rettie (1950),

\*\*Kingsley (1976a) and Kingsley and Birch (1977),

<sup>+</sup>Including Maine (Ferguson and Kingsley 1972), the area held  
by farmers was 13.1% in 1973



TABLE 4

Median Size of Forest Ownership  
in Five New England States, 1945 and 1973

	1945 <sup>a</sup>	1973	Annual % Charge
New Hampshire <sup>b</sup>	46.9	7.3	-6.4
Vermont <sup>b</sup>	41.3	13.6	-4.0
Massachusetts <sup>c</sup>	37.0	7.7	-5.5
Connecticut <sup>c</sup>	37.6	8.3	-5.3
Rhode Island <sup>c</sup>	39.2	11.6	-4.3

Source derived from:

- a. Barraclough (1949), pp. 151-154
- b. Kingsley and Birch (1977), pp. 32-33
- c. Kingsley (1976), p. 13

TABLE 5

Timber Supply Estimates for the United States  
(million cubic feet)

---

	1976	2000	% increase
National Forests	2.14	2.67	24.8
Other Public	1.09	1.27	16.5
Forest Industry	4.07	4.24	4.2
Nonindustrial Private	5.63	9.91	76.0
Total	12.9	18.1	40.3

---

Source: USDA(1979) Table 6.24, p. 327.

TABLE 6

Comparison of Private Nonindustrial Forests with  
Forest Industry and National Forest Lands

	National Forests	Forest Industry	Private Nonindustrial
Area (Million Acres)	91.924	67.341	296.234
Nonstocked (%)	3.6	2.2	4.5
Growing Stock <1500 bf/A (%)	21.1	40.4	57.7
Growing Stock >5000 bf/A (%)	49.1	27.3	12.9
Softwood Sawtimber (Mbf/A)	10.68	4.72	1.29
Growth in Growing Stock (ft <sup>3</sup> /A)	28.4	51.7	36.3
Removals/Growth	.838	1.055	.673

Source: USDA (1973) Appendix I, various tables

TABLE 7

Summary of Independent Variables

---

Acronym	Variable	Expected Relationship to Probability of Harvest
HR	Probability of Harvest	
STPI	Sawtimber price index, current dollars/Mbf	+/-
RSTPI	Sawtimber price index, \$1967/Mbf	+/-
TPI	Pulpwood/sawtimber price index, current dollars/Mbf	+/-
RTPI	Pulpwood/sawtimber price index, \$1967/Mbf	+/-
AREA	Forested area owned, Acres	+
LAREA	Natural log of AREA	+
AGE	Age of respondent, years	?
RINC	Income, constant dollar assumption, in thousands of dollars	-
NINC	Income, current dollar assumption, in thousands of dollars	-
ED	Number of years of formal education	?
C	Constant term	?

---

TABLE 8

Estimated Logit Coefficients

C	STPI	LAREA	NINC	AGE	ED	$\chi^2$ (5 df)	R <sup>2</sup>
-7.76	.128	.281	-.0151	.0135	.0269	90.8	.0640
(-10.98)	(9.09)	(4.07)	(-1.77)	(1.86)	(.815)		
	2.03	1.42	-.308	.580	.372		
C	TPI	LAREA	NINC	AGE	ED		
8.06	.172	.255	-.0148	.0169	.0342	80.6	.0565
(-11.0)	(8.30)	(3.72)	(-1.75)	(2.32)	(1.03)		
	2.22	1.28	-.300	.722	.474		
C	RSTPI	LAREA	RINC	AGE	ED		
-7.56	.124	.169	.00952	.0212	.00454	40.45	.0272
(-9.20)	(4.61)	(2.48)	(.933)	(2.78)	(.146)		
	2.06	.847	.138	.907	.0628		
C	RTPI	LAREA	RINC	AGE	ED		
-6.33	.0663	.155	.0125	.0226	.00383	24.4	.0128
(-7.61)	(1.93)	(2.28)	(1.22)	(2.92)	(.124)		
	.899	.778	.182	.961	.0528		

N = 2881

t-values in parentheses, elasticities below t-values

probability of harvest =  $1/(1-\exp(-\sum_i b_i x_i))$  where  $b_i$  are the estimated coefficients and  $x_i$  are the stated independent variables.

TABLE 9

Comparison of Farm and Nonfarm Ownerships.

	C	STPI	LAREA	NINC	AGE	$\chi^2$	L
Farm	-6.59 (2.229)	.242 (4.126) 3.74	-.162 -.3916 -.156	.0133 (.2925) .292	.0101 (.00359) .004	23.04	43.219
Nonfarm	-7.37 (-12.17)	.121 (8.094) 1.92	.287 (4.012) .279	-.0147 (-1.781) -.296	.0147 (1.874) .632	73.43	368.27

Sample Size

Farm = 264

Nonfarm = 2617

t-values in parentheses, elasticities reported below t-values

L = Value of log likelihood function

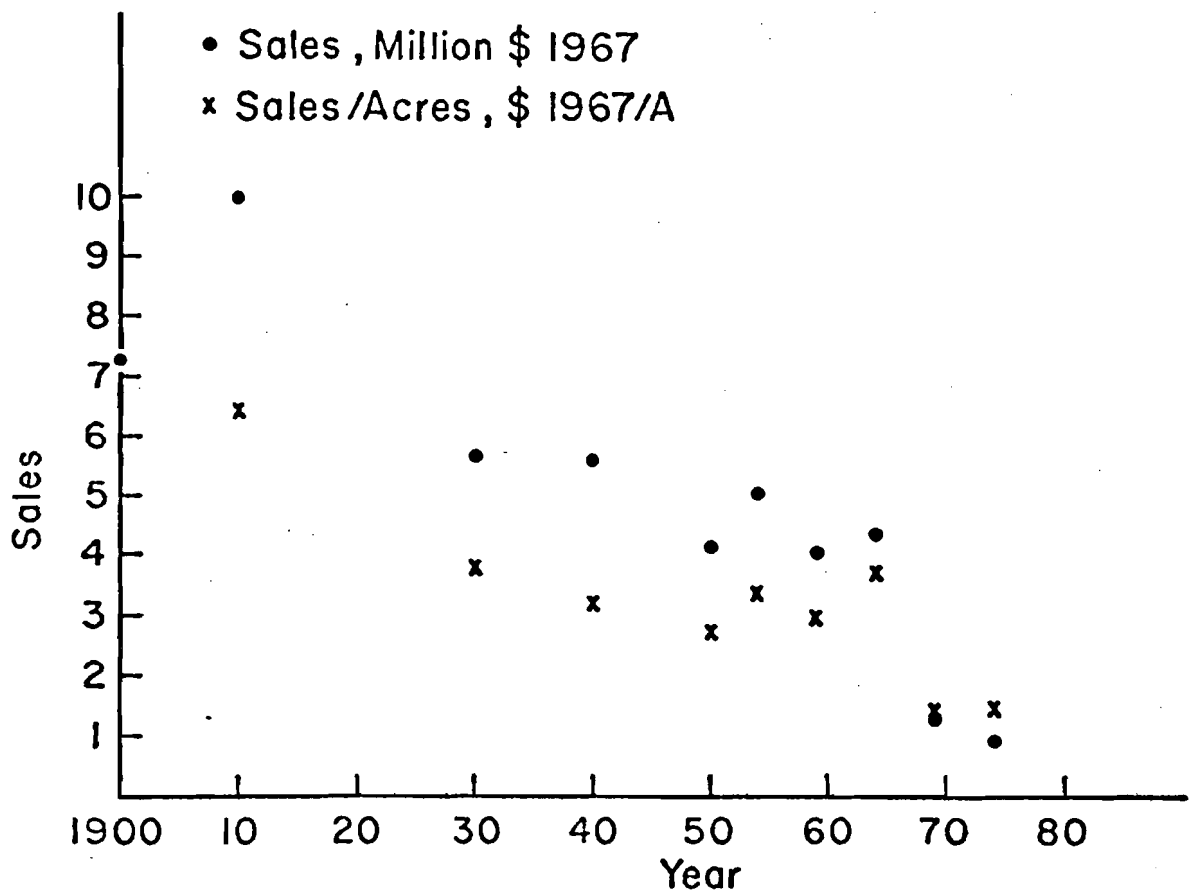

Figure 1

Sales of forest products by Vermont farms

MANAGEMENT SYSTEMS IN  
THE FOREST INDUSTRY

Paavo Uronen



## PREFACE

This paper is a survey discussing the present state and future trends of the management systems and other systems analytical tools in the Forest Industry at the corporate and mill level. The technological development has made the hierarchical distributed systems technically possible and economically attractive.

The benefits of these kind of hierarchical management systems are discussed.

The paper was presented at the IIASA Forest Industry Workshop, January 8-11, 1980.

## MANAGEMENT SYSTEMS IN THE FOREST INDUSTRY

Paavo Uronen

### INTRODUCTION

The general objectives and tasks of management in a forest industry enterprise do not differ from those in any other business management; they are (Drucker 1974): economic performance, making work productive and the workers achieving and managing social impacts and social responsibilities. In other words, management must organize the purchasing, producing, marketing, investment, maintenance and other activities in the most economical way (or fulfilling some other objective function) under many constraints in a dynamic environment and at the same time the goals and wishes of many interest groups associated with the business in question should also be met. Some other classifications for the most important tasks of management include (Dale and Michelon 1974):

Planning		(set)	goals
Directing			
Organizing		(analyze)	means
Decision-Making	or	(select)	resources
Staffing			
Controlling		(decide)	action
Innovating		(measure)	results
Coordinating			
Representing		(maintain)	Human relations

In principle each decision-making process of management will include the following steps (Sage 1978):

1. Problem definition.
2. Value system decision.
3. Modeling and analysis.

4. Alternative ranking (optimization).
5. Decision.
6. Action.
7. Evaluation.

It is thus evident that in order to make right or proper decisions, management needs plenty of information and tools, especially in points 2, 3, and 4 in the above list. Management Science, Operations Research, or Systems Analysis are more or less meaning the same discipline studying these problems and providing tools for management.

The terms "Management Science," "Operations Research," or "Systems Analysis" appeared after the second world war. These new "hard science" tools, together with the development of digital computers, gave high expectations; and many initially feared that computers and operations research would soon replace managers. That has not been, and never will be, true. Systems Analysis and computers are just tools, nothing more. They are tools with high potential for contributing to decision-making, but so far many managers in the business think that systems analysis has been quite a big disappointment (Drucker 1974). Drucker further states:

Managers complain that management scientists concern themselves with trivia and reinvent the wheel. Management scientists, in turn, tell horror stories of resistance by reactionary managers.

Systems analysis has, perhaps, put too much attention on the improvement and analysis of functional efforts (production, marketing, financing), but there has been too little emphasis on managing itself, on decision-making and on risk taking. The most important goal of these tools would be to improve the understanding of management and decision-making in business and enable managers to take the right risks. Or, putting it another way (Drucker 1974):

Systems analysis should

- test assumptions,
- identify the right questions to ask,
- formulate alternatives rather than solutions,
- focus on understanding, not on formulae.

#### SYSTEMS ANALYTICAL TOOLS AND APPLICATIONS

There are many kinds of systems analytical tools and programs available for business management. The most important techniques and tools are listed in Table 1. Typical application areas of these methods are given in Table 2. The tendency here is to combine all these methods and applications into a management information system (MIS) or management system and the updating, maintenance and further development of these models and methods is the responsibility of the Systems Group or

OR-group of the company. Figures 1 and 2 show schematically two versions of MIS and Figure 3 represents a management system as proposed by Ackoff (1972).

One interesting feature in the development of these systems in the process industry has been demonstrated in Figure 4; at early stages in the 60's the approach was a centralized one, and then attempts were made to solve both the process control tasks and the management tasks through a big centralized system. These attempts were not successful--the main reasons being insufficient reliability and capability of existing computer hardware, the difficult and complicated software, and lack of specialists. After this stage, the minicomputers were developed in the early 70's and then also the process control systems and the management systems were separated and even difficult organizations inside the company were responsible for these tasks. Today we can see very clearly the tendency towards a total mill control and management system implemented with a distributed hardware.

To what extent the above mentioned tools and systems are used in each individual enterprise is highly dependent on many factors: the branch of industry, the size of business, the regional and national characteristics and the interest and attitude of top management.

#### MANAGEMENT PROBLEMS IN THE FOREST INDUSTRY

The forest industry is a typical process industry facing many problems and structural changes now and in the future. Figure 5 is a sketch of the problem "environment" of the manager in a forest industry enterprise. It is obvious that corporate management today cannot make the decisions by taking only the interests of the company and the technological aspects into account. More and more the social impacts, the goals of many interest groups (stock-holders, labor unions, government, environmentalists, forest owners, etc.) must also be taken into account and the development, both global and national, in this industry should also be forecasted and notified in decision-making. Figure 6 gives a schematic hierarchy of the problems in the forest industry.

For assisting management in these tasks in the forest industry, most of the methods mentioned in Table 1 could be, and to some extent are, used at the corporate and mill levels. The big problem is the lack of models and forecasts at the upper levels of hierarchy in Figure 6. Also decision-making under many constraints and trying to satisfy all the goals of the different interest groups will lead to a multicriteria optimization problem. The latest developments in multiobjective optimization (Wierzbicki 1979) and game theory may give useful tools for these problems in the future. These problems are closely connected to strategic planning, i.e., to long-term (time horizon: several years) management of the company. The manage-

Table 1. Management techniques and tools.

---

Data base techniques  
Modeling techniques  
Simulation techniques  
Optimization techniques  
    -- LP  
    -- Integer programming  
    -- Non-linear programming  
    -- Dynamic programming  
    -- Multiobjective optimization  
Forecasting methods  
    -- Linear time trend  
    -- Moving average  
    -- Exponential smoothing  
    -- Non-linear time trends  
    -- Adaptive forecasting  
    -- Box-Jenkins  
Inventory control theory  
Value analysis  
Optimal control theory  
Game theory  
Critical path scheduling and other project control systems  
Heuristics  
Reporting systems

---

Table 2. Applications of systems analysis in management.

---

Corporate modeling  
Strategic planning  
Budgeting  
Cash flow analysis  
Financial forecasting  
Financial analysis  
Demand and sales forecasts  
Profit planning  
Marketing management and planning  
Investment analysis  
Production planning  
Production coordination and control  
Project control  
Planning of transportations  
Inventory control

---

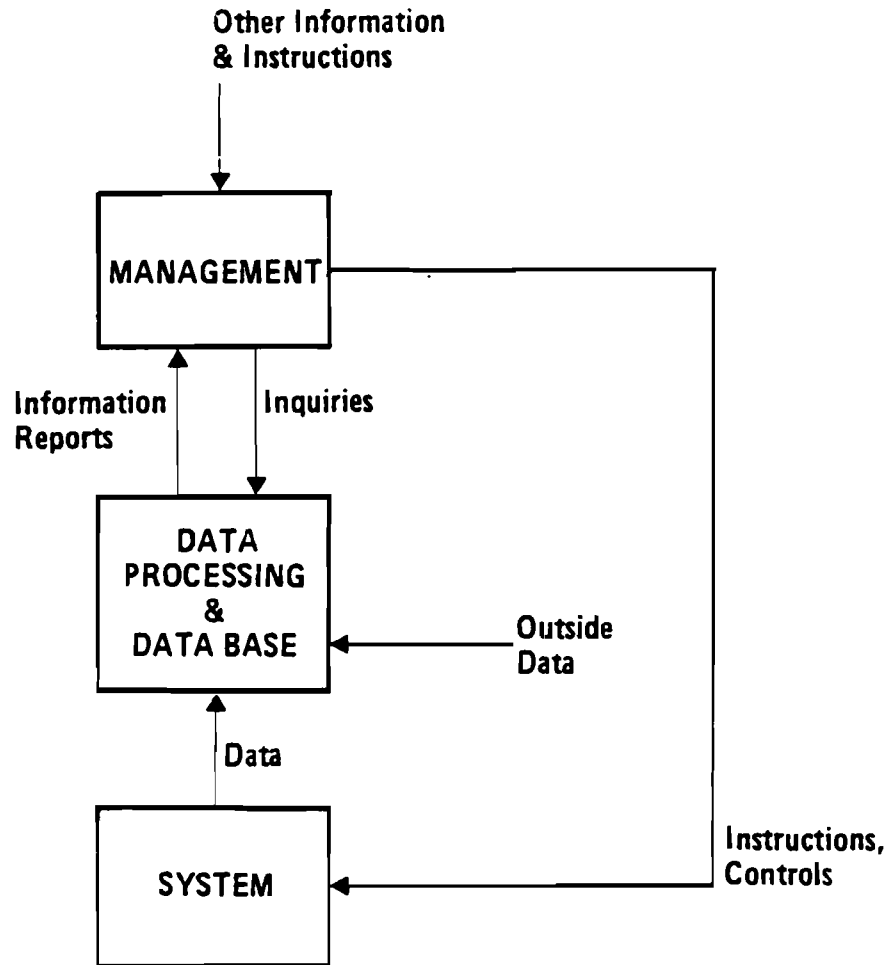

Figure 1. Management information system I.

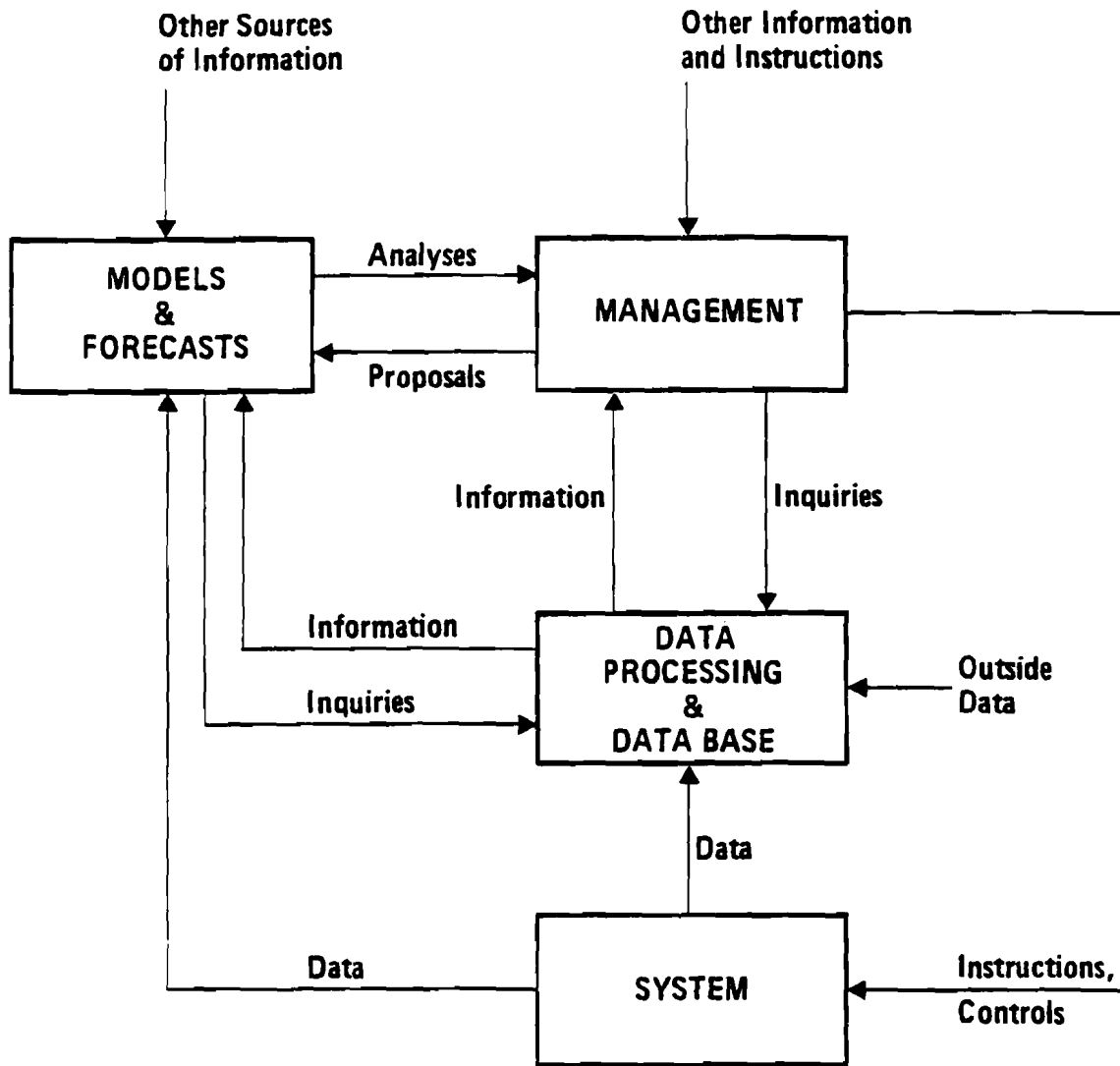

Figure 2. Management information system II.

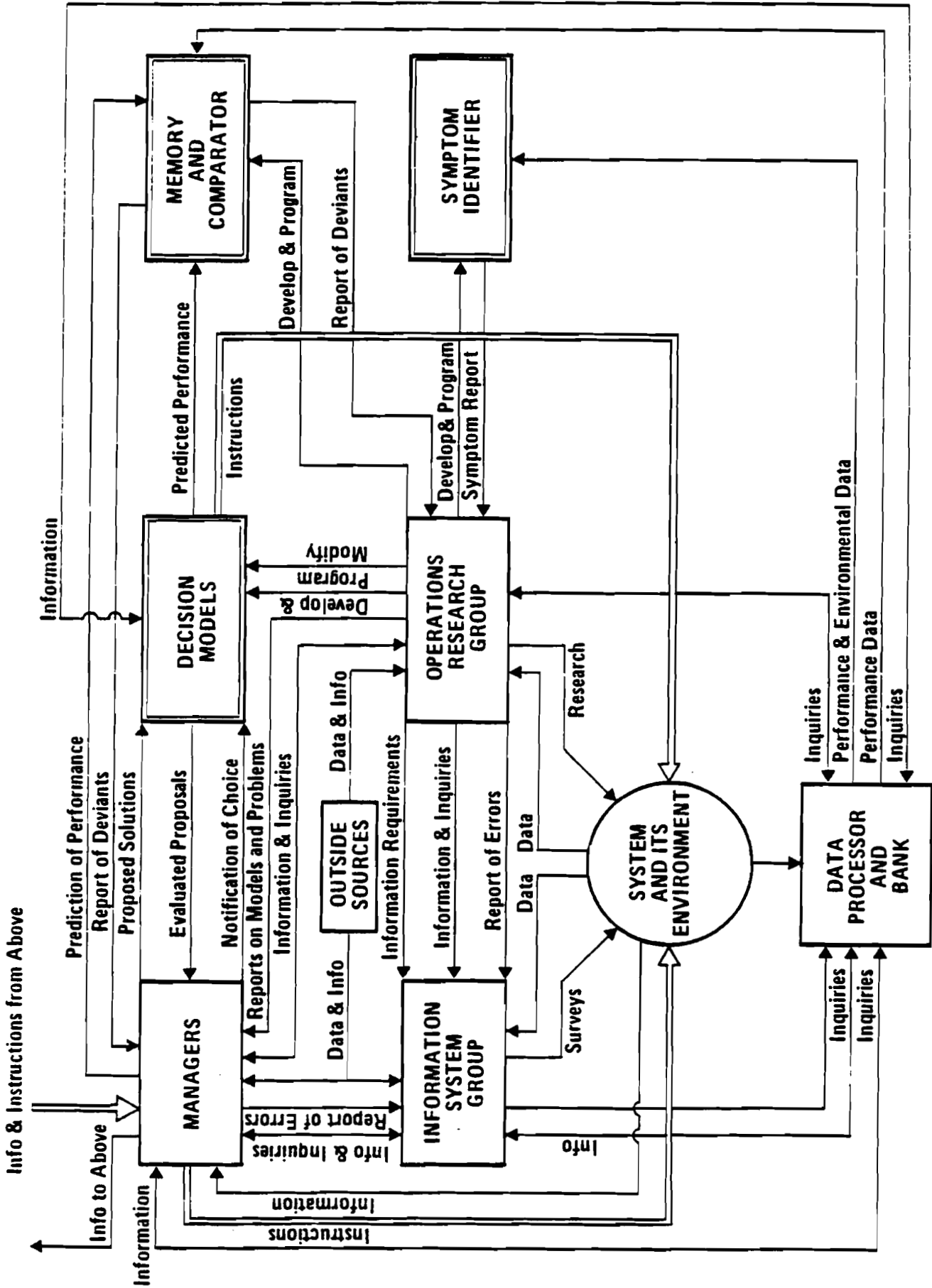

Figure 3. Management system suggested by Ackoff (1972).



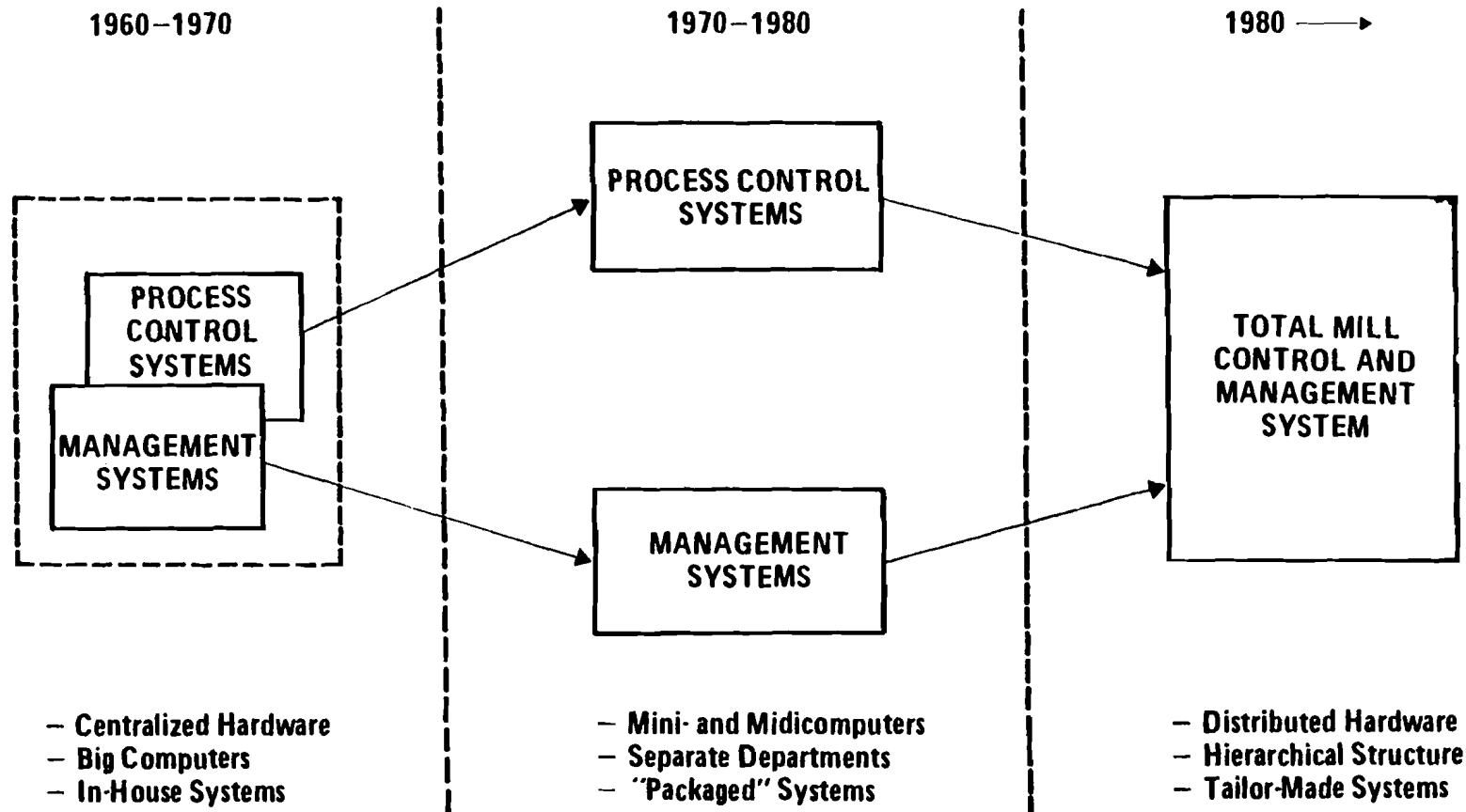

Figure 4. Development of control and management systems.

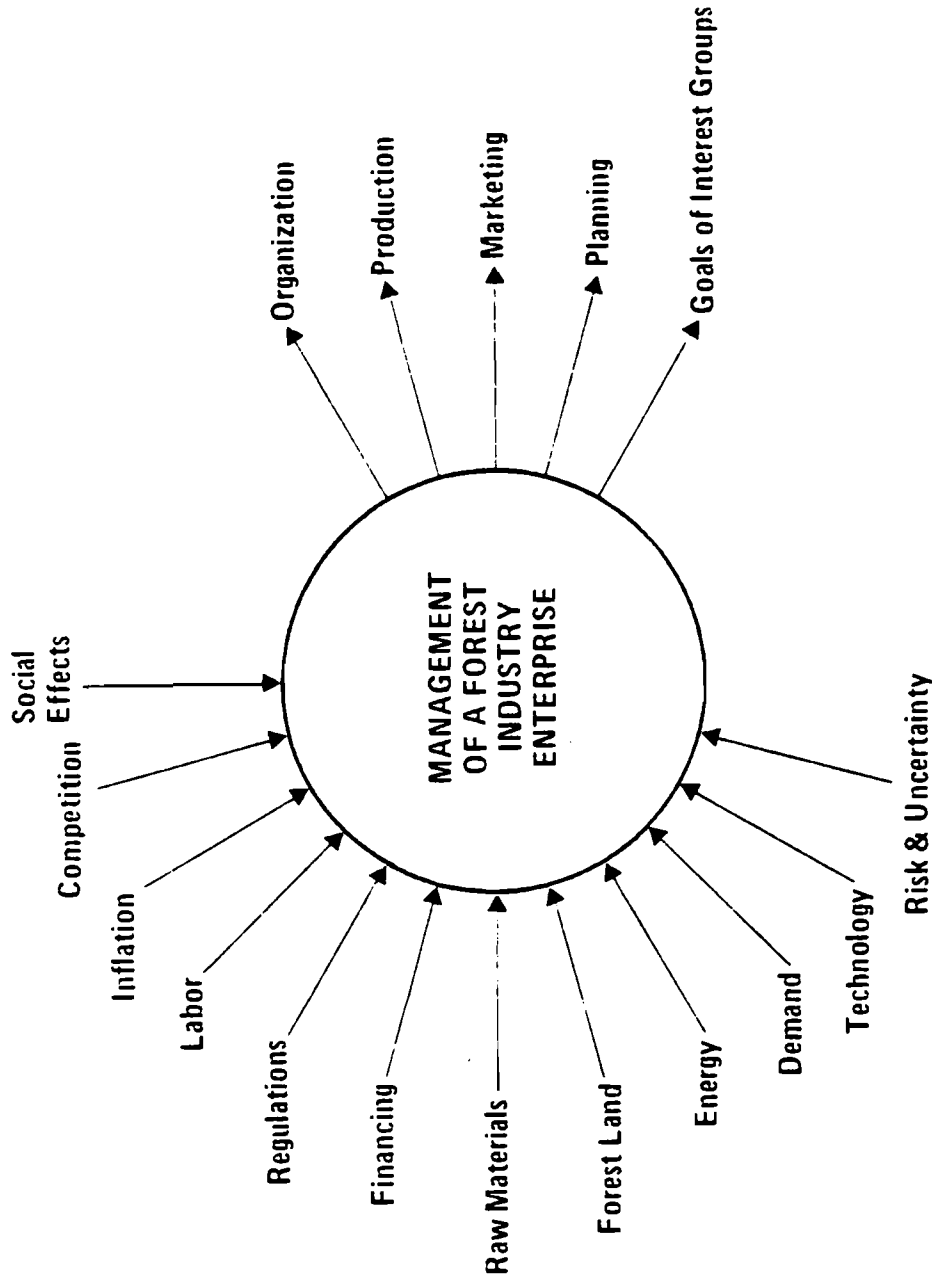

Figure 5. Management "environment" in a forest industry enterprise.

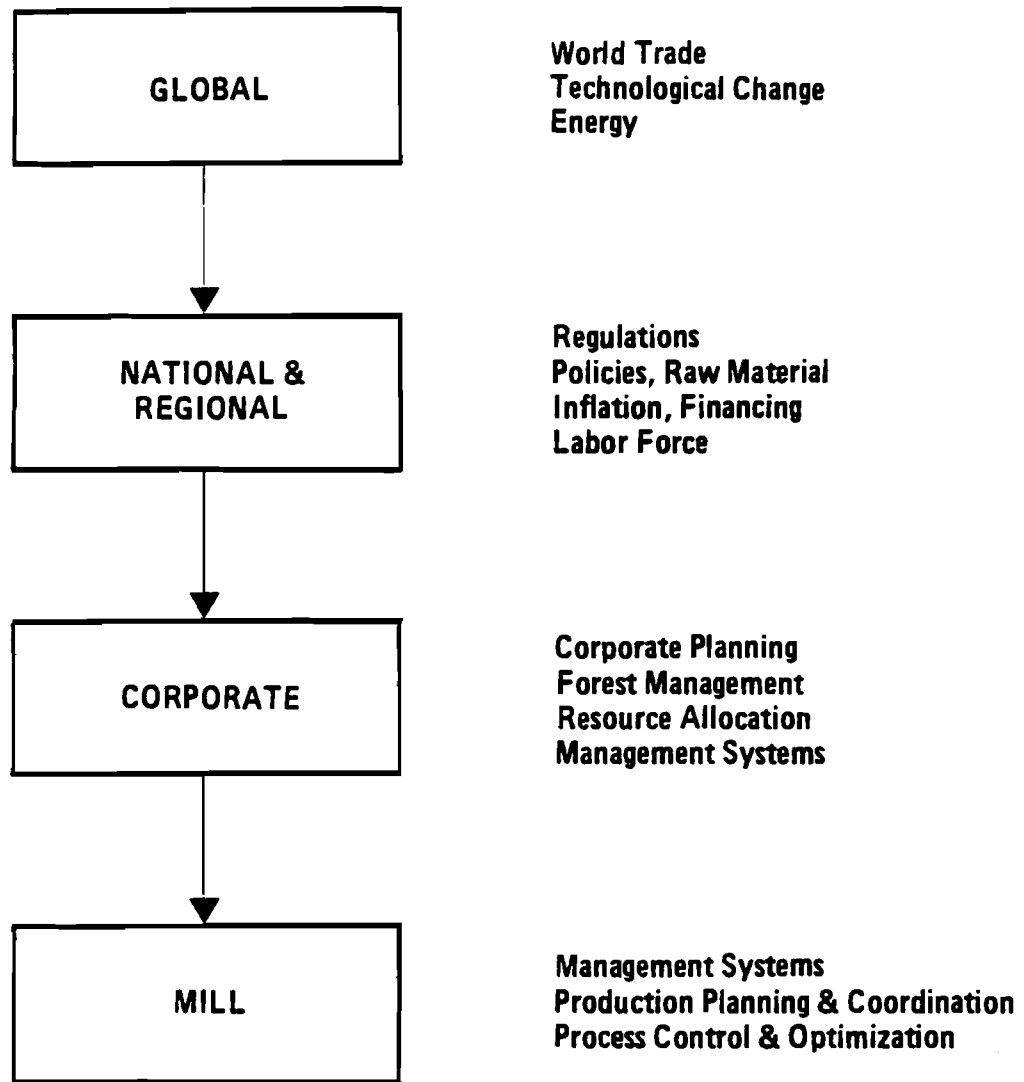

Figure 6. The hierarchy of management and planning problems.

ment tasks in a forest industry enterprise can be divided according to the time span as follows:

-- Strategic planning	time horizon:	years
-- Tactical planning	" "	months-
		year
-- Production planning	" "	1-7 days
-- Production coordination	" "	1-24 hours
-- Process optimization	" "	1-60 mi-
		minutes
-- Process control	" "	0-1 mi-
		minute

Another classification is:

Strategic management	long-term, (goals)
Tactical management	short-term, (means)
Operative management	real-time, (production)

For strategic management, typical systems analytical tools are corporate models and forecasts (Zackrisson, et al. 1977). The models needed are typical simulation models used to answer questions like: "What is the outcome if this decision or change will be made?"

For tactical management the most important tasks are budgeting and resource allocation; so budgeting and reporting systems, demand and sales forecasts, marketing and financial analyses are the tools needed.

The operative management of a mill is responsible for the fulfillment of the incoming order flow at the most efficient way taking several constraints and uncertainties into account. Figure 7 gives a diagram of the production planning system of a white paper mill. This kind of production planning system would be a part of a total mill information and management system as depicted in Figure 8.

Vital parts of this kind of system are several data bases which will draw data from the processes (via measurements) and from outside sources (via terminals). These data bases are updated and they are important data sources also for other management systems (tactical and strategic); thus all systems will be combined together.

Figure 9 presents two typical decision-making situations for operative management in the forest industry enterprise. The upper case represents a situation where the markets do not restrict, i.e., all what can be produced can be sold. In this situation management must decide the optimal product mix. The lower case represents a situation where the markets are limited and the orders coming in should be scheduled in production in the most economical way.

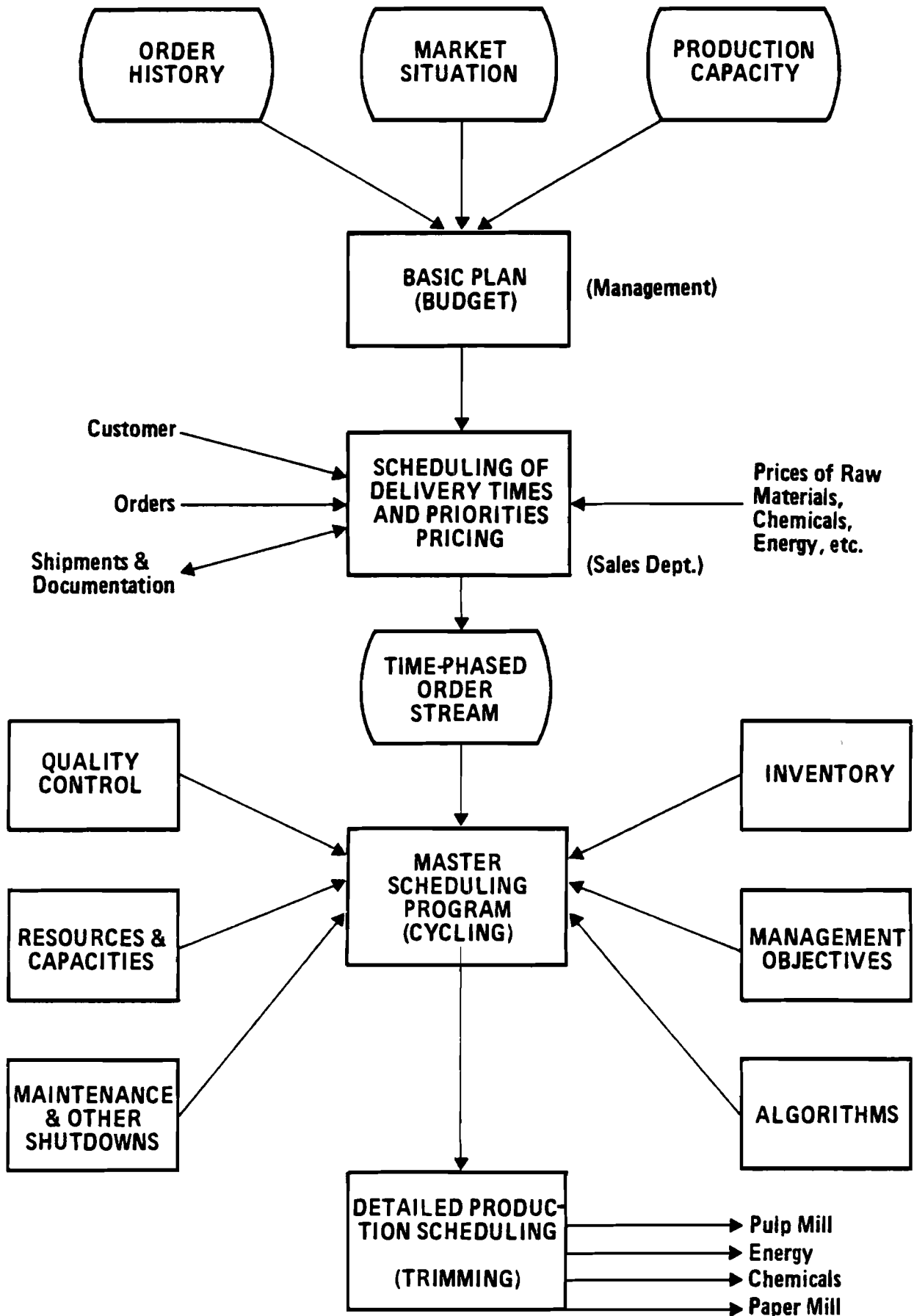

Figure 7. Master production scheduling process.

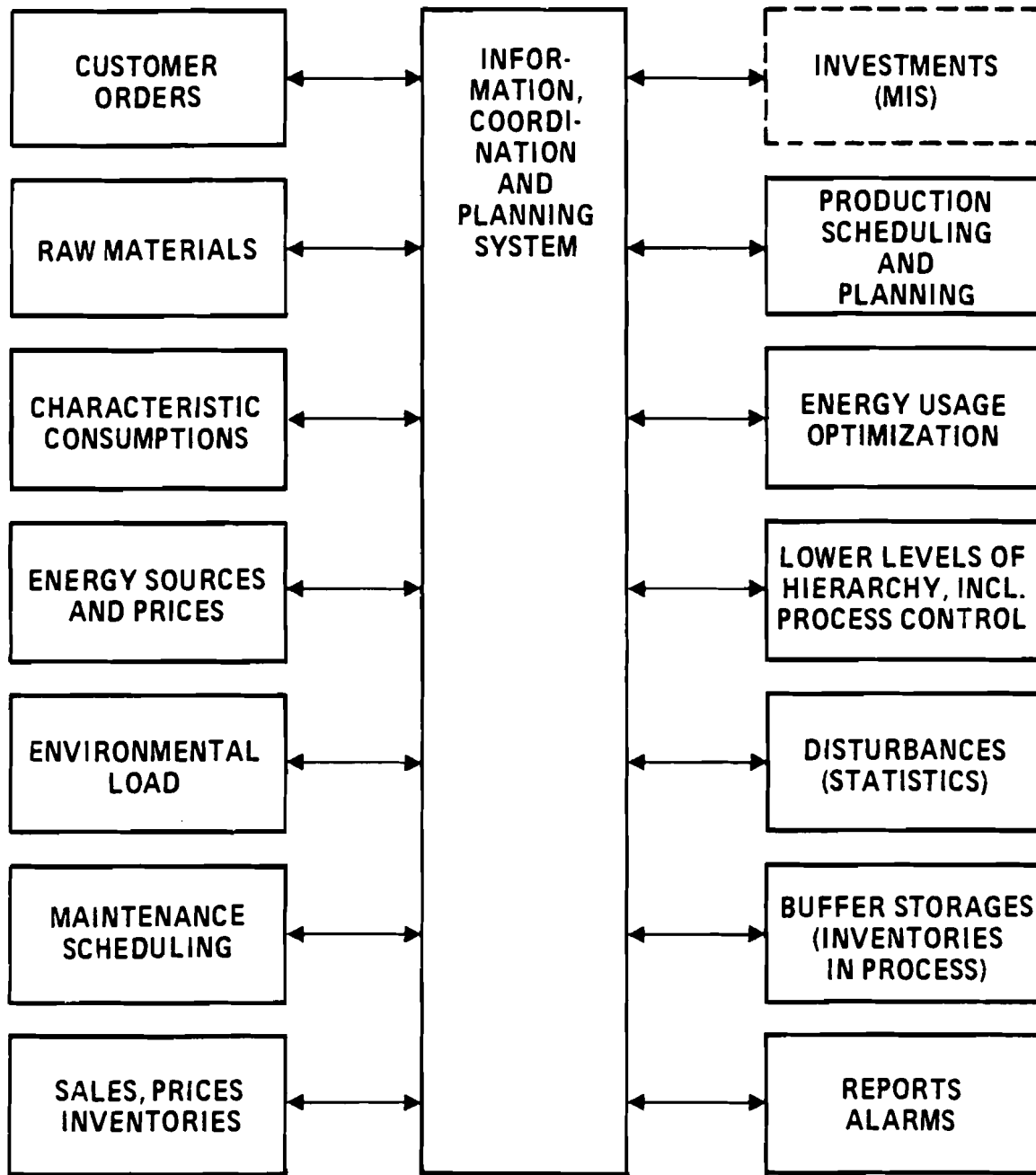

Figure 8. Tasks of total mill information and production planning system.

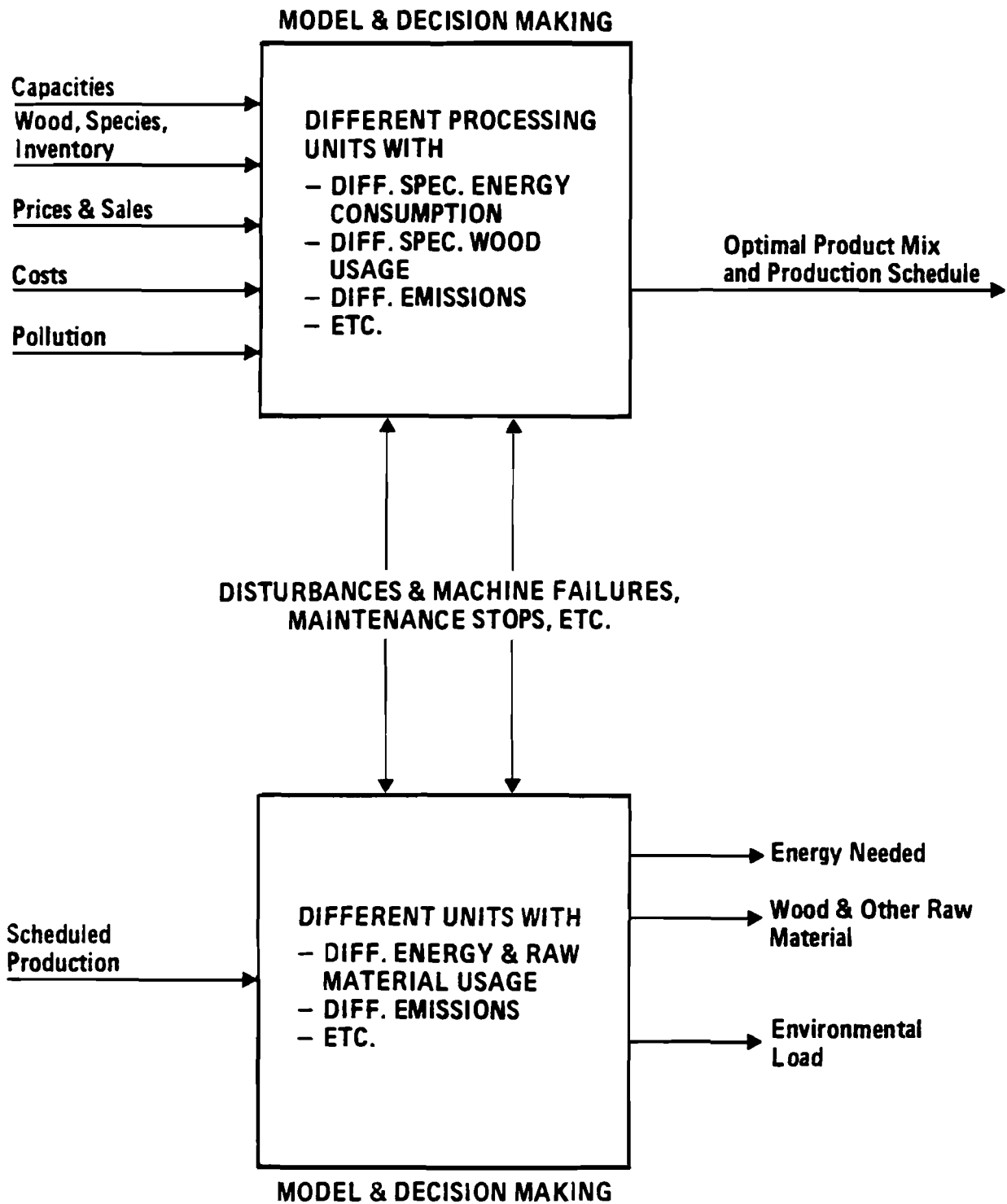

Figure 9. Typical problems to be solved in production planning.

Production planning should be done so that the use of equipment would be as even as possible, avoiding shut-downs, start-ups, rate changes, and overflowing, or emptying of in-process storages, etc., because there are several possible losses and disadvantages connected to all such changes as shown in Figure 10 (Uronen 1978). A real-time total mill information and management system, as depicted in Figures 7 and 8 can remarkably shorten the total control cycle time of the business thus preventing losses and improving the productivity as Figure 11 demonstrates (Uronen 1979). The development of computer hardware makes the implementation of these ideas in a hierarchical system with distributed hardware realistic and profitable. One possible structure of such a hierarchical system is proposed in Figure 12 (Uronen and Williams 1978).

#### STATE-OF-THE-ART IN THE FOREST INDUSTRY

No survey or state-of-the-art report concerning the use of systems analysis in the management of forest industry enterprises exists. One area, namely process control, is quite well covered in several surveys (Gee and Chamberlain 1977; Keyes 1975; Uronen and Williams 1978), and also the situation in recent years (Eriksson 1978; Uronen and Williams 1978). Thus a study of the applications and experiences concerning the use of the more "classical" type of systems analytical tools (corporate modeling, forecasts, etc.) in the forest industry would be necessary and useful giving feedback for research and development work in this area.

We can, however, assume that the situation concerning the use of these methods in the forest industry is far analogous to the situation in other branches of industry. Naylor and Schauland (1976) did a survey study in the US concerning the use of corporate planning models. The study concerned the situation in 1974-75 and they received answers to their questionnaire from 346 corporations representing 19% response. Some of their results are given in Tables 3-6. From Table 3 we can see that the response from the forest industry has been very limited, if any, and it has been included into group 'other'. Perhaps the most interesting is Table 6 which lists the benefits of corporate modeling; the main benefits are closely related to policy analysis and decision-making; the direct cost savings are mentioned only in 28% of the cases and only 4% of the answers do not indicate any benefits at all. We must, however, keep in mind that this study concerned only one application area of systems analysis, namely the corporate modeling. This is, of course, a central and important application but in order to be able to evaluate the whole range of applications, especially in the forest industries a survey study must be carried out.

Concerning the present situation in the area of hierarchical real-time management information and production planning systems, some existing systems are in operation (Eriksson 1978; Uronen 1978). Figure 13 shows the functional levels of hierarchy installed at A. Ahlstrom's Paper Mill in Finland (Uronen 1978).



Table 3. Firms using corporate models classified by industry.

Industry	Number of Firms
Manufacturing	64
Banking and Finance	30
Regulated Industries (transportation, communications, utilities)	20
Service	15
Mining	7
Agriculture	5
Others	18
No response	54
TOTAL	213

Source: Naylor, Schauland, 1976

Table 4. Applications of corporate models

Applications	Percentage
Cash flow analysis	65
Financial forecasting	65
Balance sheet projections	64
Financial analysis	60
Proforma financial reports	55
Profit planning	53
Long-term forecasts	50
Budgeting	47
Sales forecasts	41
Investment analysis	35
Marketing planning	33
Short-term forecasts	33

Source: Naylor, Schauland, 1976

Table 5. How corporate models are used

Use	Percentage
Evaluation of Policy Alternatives	79
Financial Projections	75
Long-Term Planning	73
Decision-Making	58
Short-Term Planning	56
Preparation of Reports	47
Corporate Goal Setting	46
Analysis	39
Confirmation of Other Analysis	35

Source: Naylor, Schauland, 1976

Table 6. Benefits of corporate models

Benefits	Percentage
Able to Explore More Alternatives	78
Better Quality Decision-Making	72
More Effective Planning	65
Better Understanding of the Business	50
Faster Decision-Making	48
More Timely Information	44
More Accurate Forecasts	38
Cost Savings	28
No Benefits	4

Source: Naylor, Schauland, 1976

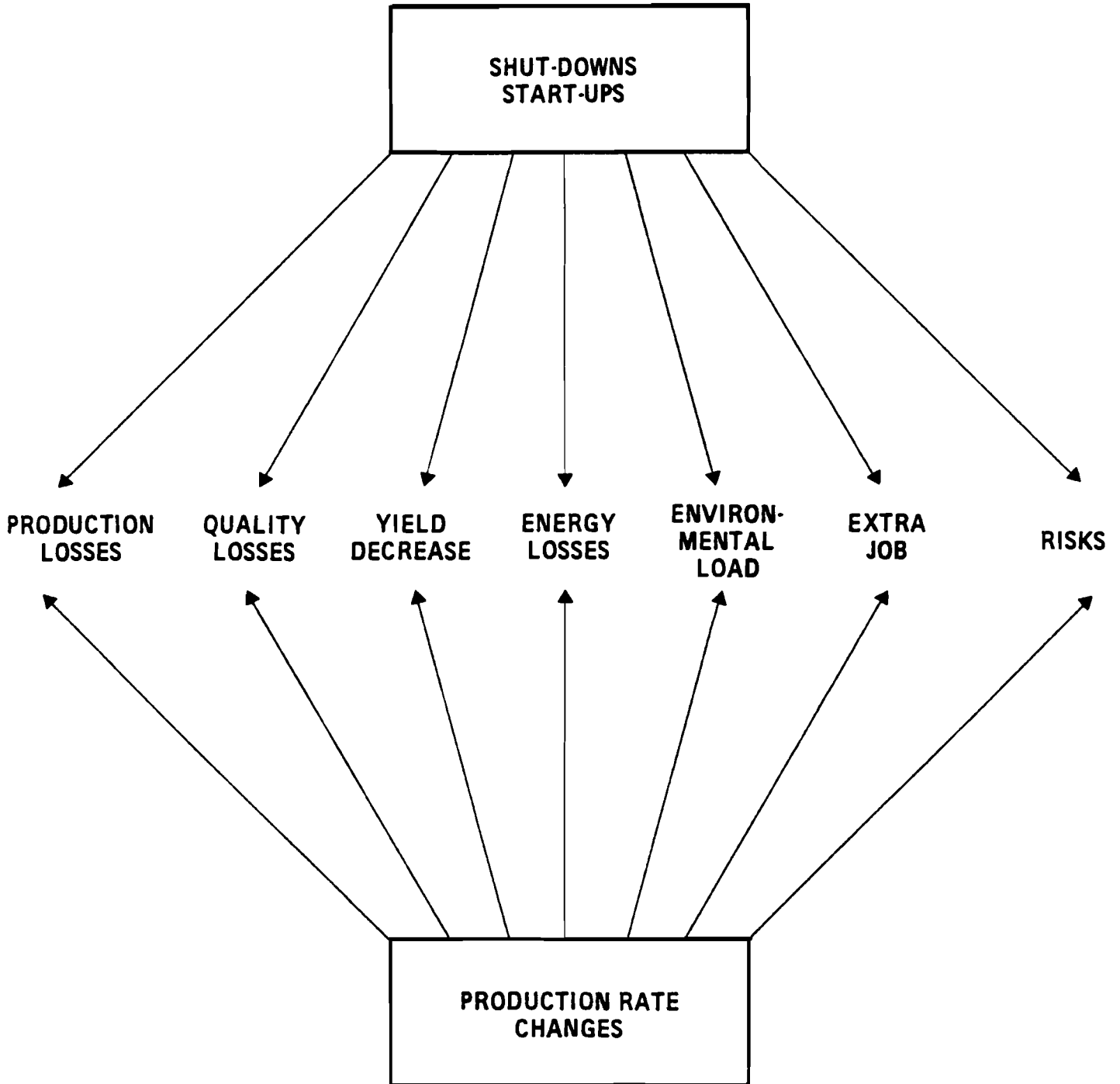

Figure 10. Some undesired effects of mill shut-downs and production rate changes. (Uronen 1978)

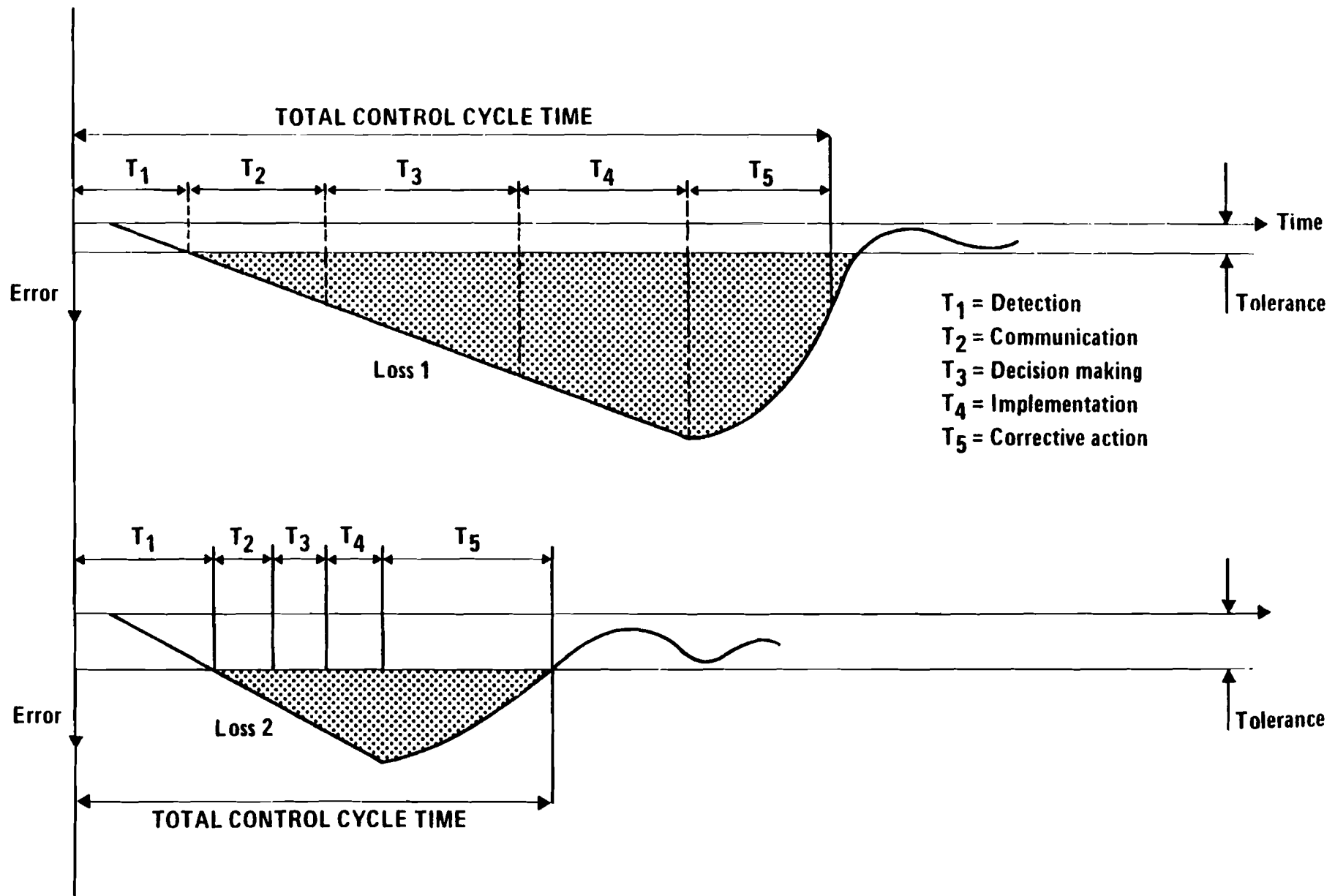

Figure 11. Real-time total mill information and control system can remarkably shorten the total cycle time thus improving profitability. (Uronen 1979)

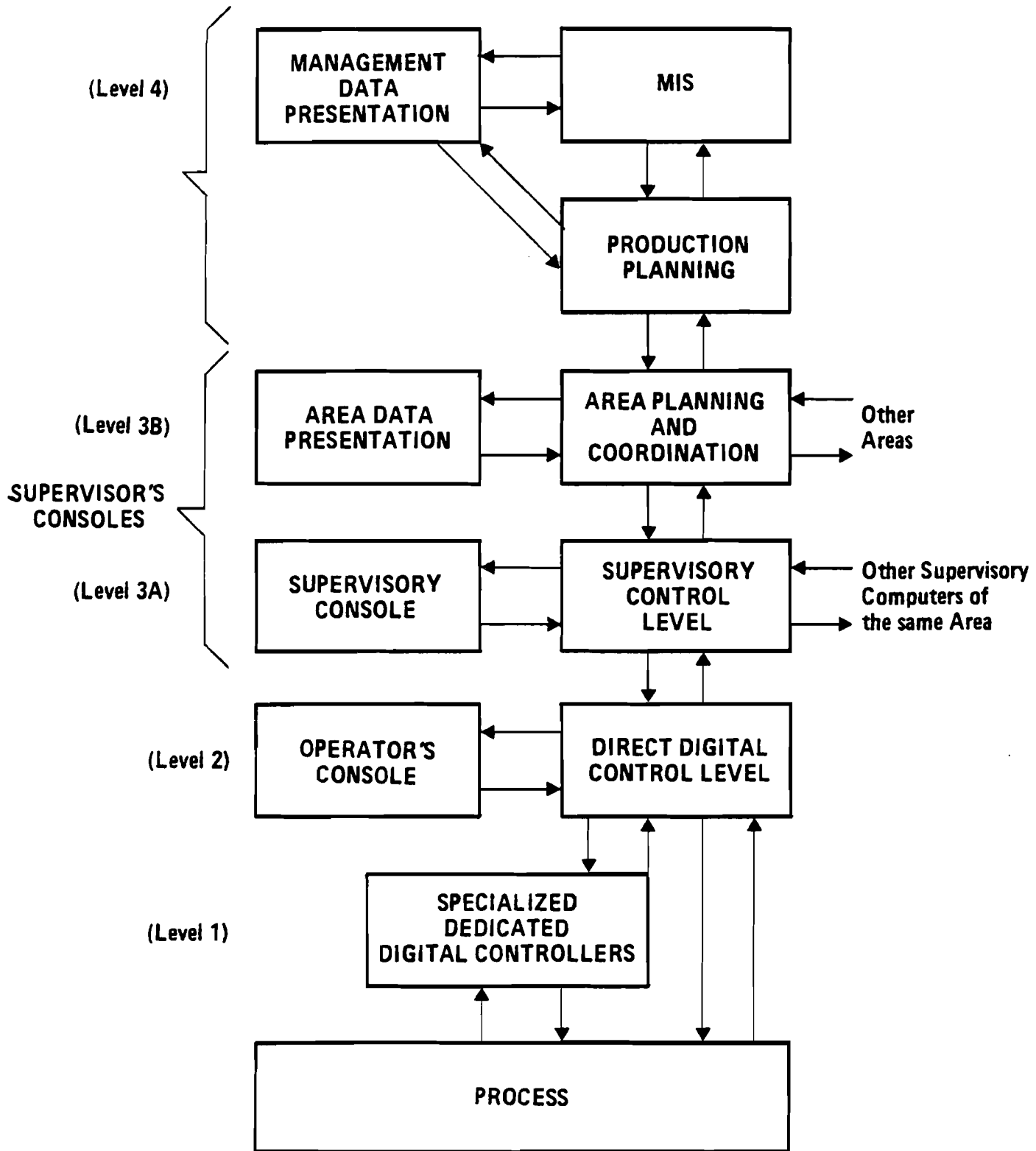

Figure 12. Proposed general hierarchy.  
(Uronen and Williams 1978)

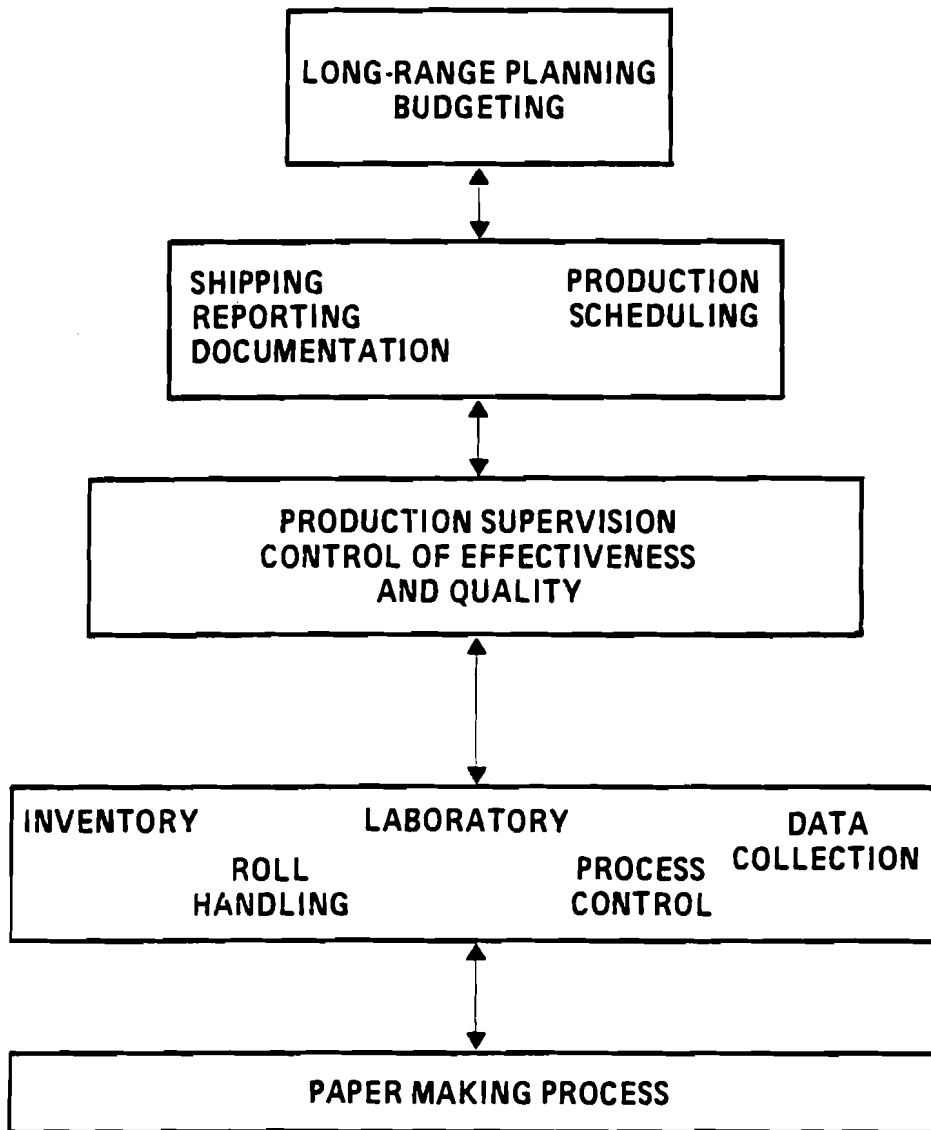

Figure 13. Hierarchical production planning and control at A. Ahlstrom's paper mill, Varkaus, Finland. (Uronen 1978)

The number of this kind of systems is expected to increase rapidly in the 80's and at the same time these systems will be combined more and more with corporate models and other management tools, thus forming a total management system for the company.

#### FUTURE DEVELOPMENT

It is obvious that despite disappointments and time lags the use of systems analytical tools in the forest industry, as well as in other industries, will increase continuously in the future. The following trends and needs can be seen:

- the systems analytical models and tools will be more and more connected to production planning and control systems thus forming a hierarchical total mill management and information system. Then also the gaps and time lags between the planning, production, marketing and financing will be decreased and the overall control and decision-making will be faster and more integrated.
- many companies are planning to build corporate models and management information systems. It is important that the needs of the users of these systems will be taken into account already in planning. Top management should also be involved in planning.
- there is a need for the development of new user oriented programming languages, for example, for planning and budgeting.
- the connection between corporate models and production planning systems will become more important.
- most corporate planning systems do not, so far, include optimization procedures. It is probable that the use of optimization techniques in production planning and goal programming in resource allocation will increase rapidly.
- new models are needed for external environment, i.e., for economic, regional, social, ecological and political problems connected with the forest industry enterprise.
- a continuous dialogue between the systems analysts and the users of these tools is in essence.

REFERENCES

- Ackoff, R.L. 1972. The Evolution of Management Systems, Management and Technology, Vol. 1, on Anglo-American exchange of views, Editor: Alan Mercher, Interlink.
- Dale, E., L.C. Michelon. 1974. Modern Management Methods, Pelican Books.
- Drucker, P.F. 1974. Management; Tasks, Responsibilities, Practices, W. Heinemann, London.
- Eriksson, L. 1978. Survey of Multi-Level Computer Control Systems in the Pulp and Paper Industry, IFAC Seventh Triennial World Congress, Preprints Vol. 1, Helsinki.
- Gee, J.W., R. E. Chamberlain. 1977. Digital Computer Applications in the Pulp and Paper Industry, 5th IFAC/IFIP International Conference on the Digital Computer Applications to process Control, Den Haag, Netherlands.
- Keyes, M.A. 1975. Computer Control Census, Tappi, Vol. 58, No. 6, June.
- Naylor, T.H., H. Schauland. 1976. A Survey of Users of Corporate Planning Models, Management Science, Vol. 22, No. 9, May.
- Sage, A.P. 1977. On the Application of Systems Methodology of Economic and Organizational Management of Integrated Industrial Complexes, Proceedings of the IFAC Workshop "Control and Management of Integrated Industrial Complexes", Toulouse, France, 6-8 September.



- Uronen, P. 1978. Trends in Pulp and Paper Mill Control, Paper presented at Purdue Workshop, April, West Lafayette, USA.
- Uronen, P. 1979. Zukunftsaussichten der Steuerungssysteme und Optimierung von Prozessen in der Zellstoff- und Papierindustrie, Paper presented at the 74, Hauptversammlung des Vereins Zellcheming, Baden-Baden, June 26-29.
- Uronen, P., T.J. Williams. 1978. Hierarchical Computer Control of an Integrated Pulp and Paper Mill, Report No. 111, Purdue Laboratory for Applied Industrial Control, West Lafayette, Indiana.
- Wierzbicki, A.P. 1979. The Use of Reference Objectives in Multi-objective Optimization--Theoretical Implications and Practical Experience. IIASA Working Paper, WP-79-66, Laxenburg, Austria.
- Zackrisson, U., L. Ekström., A. Baudin. 1977. Forecasting--A Competitive Device, Paper, Vol. 188, No. 7, October.

Kauko Leiviskä

METHODS FOR PRODUCTION PLANNING IN AN  
INTEGRATED PULP AND PAPER MILL

Abstract. Three approaches to carry out the pulp mill production control calculations are discussed. These approaches are a simulation method, a hierarchical optimization algorithm and a network flow algorithm.

In the simulation approach a general program package for the production control calculations was developed. The scheduling is based on a simulation model and some simple logical rules for production scheduling. It proceeds iteratively from a given production schedule to a production schedule that satisfies all the system constraints.

The production schedules of both the pulp lines of the mill and the chemical recovery cycle can be calculated using Tamura's time delay algorithm. This algorithm was modified so that the specific features of the problem can be taken into account. These include the compensation of planned shut-downs, identification of infeasible situations, etc.

The use of standard linear programming algorithms to production control calculations is restricted by the fact that they need a considerable amount of core memory. However, for some special cases network flow algorithms that can solve

LP-problems have been developed. In this connection Ford-Fulkerson out-of-kilter algorithm is considered.

The applicability of these approaches was compared using simulations with UNIVAC 1100/20-computer of the University of Oulu. In the simulations the preselected simulation period of 48 hours was divided into intervals of 8 hours. Several kinds of test runs that correspond problems in the real plant environment were carried out.

Keywords. Production control; simulation; hierarchical systems; linear programming; pulp industry.

## INTRODUCTION

During the last few years the need for a production control and a total mill information system in pulp and paper mills has become actual. Production control includes the short term production scheduling and the control of the mill operations according to customer orders or the long term production schedule. The operation of the production control system is based on real-time information from the mill because of the dynamic nature of the mill operation conditions. Depending on the mill in question, the tasks of the production control system vary from the order handling to the optimization of mill operations.

Figure 1 presents a hierarchy of operations, which is very typical also in other industries, not only in pulp and paper mills.

The lowest level consists of the process instrumentation. The development of the technology has been very fast on this level. Fast and cheap microprocessor based instrumentation systems and high-speed serial data communication systems are changing the tasks of conventional control

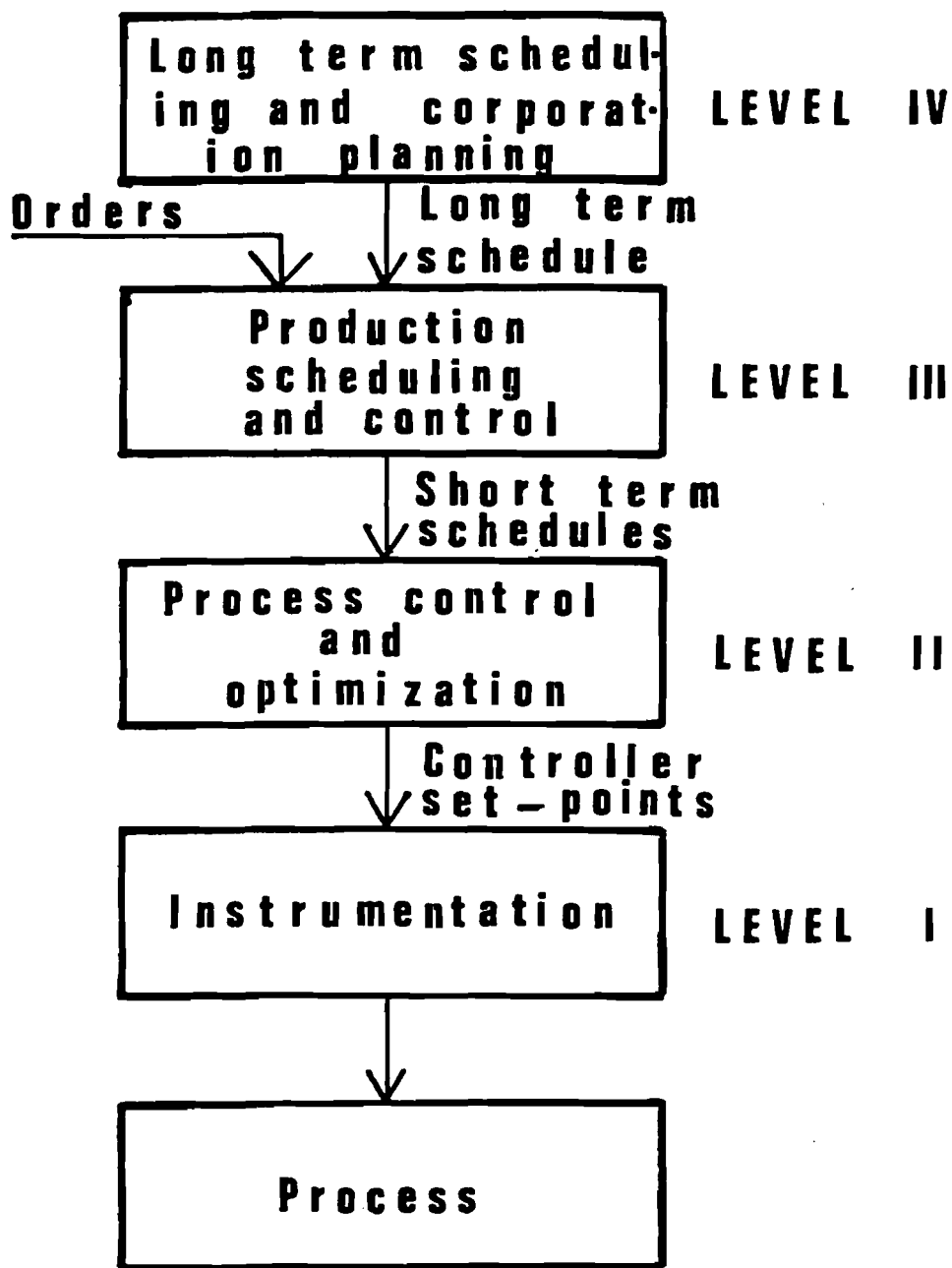

Figure 1. A hierarchy of mill operations

computers. Data acquisition and preliminary handling are more and more carried out by instrumentation systems and by intelligent measuring systems. However, the control actions carried out on this level concern mostly stabilizing control based on the reference values given by the upper levels.

The next level is the process control and optimization level. Typically this level uses process computers and for all the pulp and paper mill processes automatic computer control systems have been developed. These systems utilize real-time measurements, process models and control algorithms. They provide, for instance, the set points for the controllers, and special reports for both upper and lower levels of the hierarchy.

Process optimization which takes place on the same level, requires the knowledge of the overall process models. Usually only static optimization is used. This means that the optimal steady-state conditions of the process are determined according to the production requirements. Process optimization can be included as a task of the computer control system.

The third level is responsible for the production control. As it was shown above the production control converts the customer orders or the planned production schedule to short term production schedules for all the processes. The tasks and functions of the production control system are considered later on in this text.

The level above the production control level includes the long term production planning for intervals varying from a month to several years. Also the models used on this level are developed keeping longer time intervals in mind.

Sulphate pulp mill is a complex system consisting of processes and storage tanks between them. The processes are linked together by fibre, chemicals and energy flows. Because of the system complexity and strong interactions disturbances in one process have an effect on the operation of other processes. The effect of these disturbances can be decreased by efficient coordination and control system. This production control system includes all the operations connected to actual production and consumption and generation of energy. Figure 2 shows inputs, outputs and main functions of the system.

The production control system must provide the operational staff with the production schedules calculated for the scheduling period of 2...3 days. These production schedules must assure the most economical production taking the capacity of the processes and the constraining storage capacity into account.

The system must also give following information:

1. What effects the deviations from the optimal production schedules have on the operation?
2. What is the most advantageous state in the case of random disturbances?
3. How the planned shut-downs are included in the production schedules?

With an efficient production control and coordination system the mill capacity can be increased. This is achieved because

1. Better coordination decreases the number of shut-downs enforced by full or empty storage tanks.
2. Better coordination makes more efficient use of the bottleneck process possible.

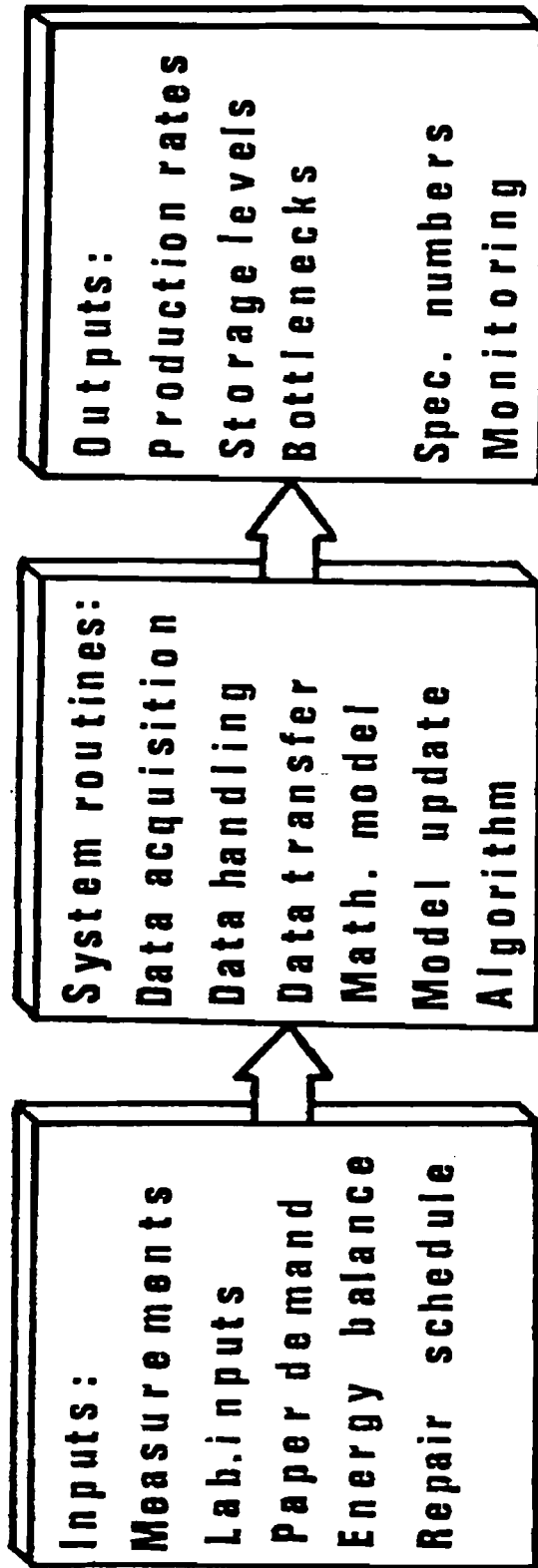

Fig. 2. The main functions of a pulp and paper mill production control system.

3. Also the number of shut-downs enforced by an incorrect coordination of the energy balance can be decreased.

As another benefit the decreased amount of quality disturbances can be considered. This is achieved because of fewer production rate changes and fewer start-ups. More reliable reporting, effective coordination of environmental effects and also decreased staff in some cases are other benefits of the production control system.

Previously, the application of simulation, linear programming and optimal control methods to pulp and paper mill scheduling has been considered (Pettersson, 1969, 1970 a,b,c, Alsholm and Pettersson, 1970). Simulation has also been used in storage dimensioning and control strategy optimization (Golemanov, 1972, Golemanov and Blomberg, 1973). In the same connection also mathematical programming for optimal production control was concerned (Golemanov, 1972, Golemanov and Koivula, 1973). A network flow algorithm has been used in a computer-based production control system in calculating the production schedules (Edlund and Kalmén, 1974, Edlund and Johansson, 1977, Edlund and Rigerl, 1978). Also the discrete maximum principle has been applied for production scheduling of a pulp mill fibre line (Chalaye and Foulard, 1976). In former studies hierarchical optimization algorithms, namely Tamura's time delay algorithm and the suboptimal algorithm of Singh and Coales, have been found applicable to pulp mill production scheduling (Leiviskä, 1979, Leiviskä and Uronen, 1979 a,b).

#### PULP MILL MODEL

Production control calculations give the production schedules of pulp mill processes with the time horizon of 2...3 days. Therefore it is not necessary to use complete, complicated process models. If all the small storage tanks are included in the model, the system dimensions increase so that it be-



comes very difficult to deal with. The model can be simplified by combining smaller storage tanks. Very small tanks can be left without consideration by 'lumping' together the corresponding processes.

In the following a sulphate pulp mill producing bleached pulp and consisting of a fibre line and a chemical recovery cycle is considered as an example. Figure 3 shows the flow diagram of this kind of mill together with the necessary notations for modelling. In modelling typical operational parameters of the pulp mill processes are used. Eventhough both the mill flow diagram and the parameters are hypothetical, this does not decrease the value of the results. Using a hypothetical mill the applicability of these approaches can be compared generally. In a specific application some problems may arise in modelling and in on-line measurements etc., but these problems are same for each method.

The system consisting of processes and storage tanks can be modelled in the state space form

$$\bar{\dot{x}} = B\bar{u} + C\bar{v} \quad (1)$$

Here the control variable  $\bar{u}$  denotes the production rates of the process departments and  $\bar{x}$  the amount of material in the storage. The required production schedule of pulp is denoted by the deterministic disturbance variable  $\bar{v}$ .

The steam balance can be written as

$$S = D\bar{u} + E\bar{v} \quad (2)$$

where  $S$  is the production rate of the auxiliary boiler. Equations 1 and 2 can be written if:

1. The dynamics of each process can be neglected. This is possible because the time delays after the production rate changes are reasonable short compared with the time scale of optimization.

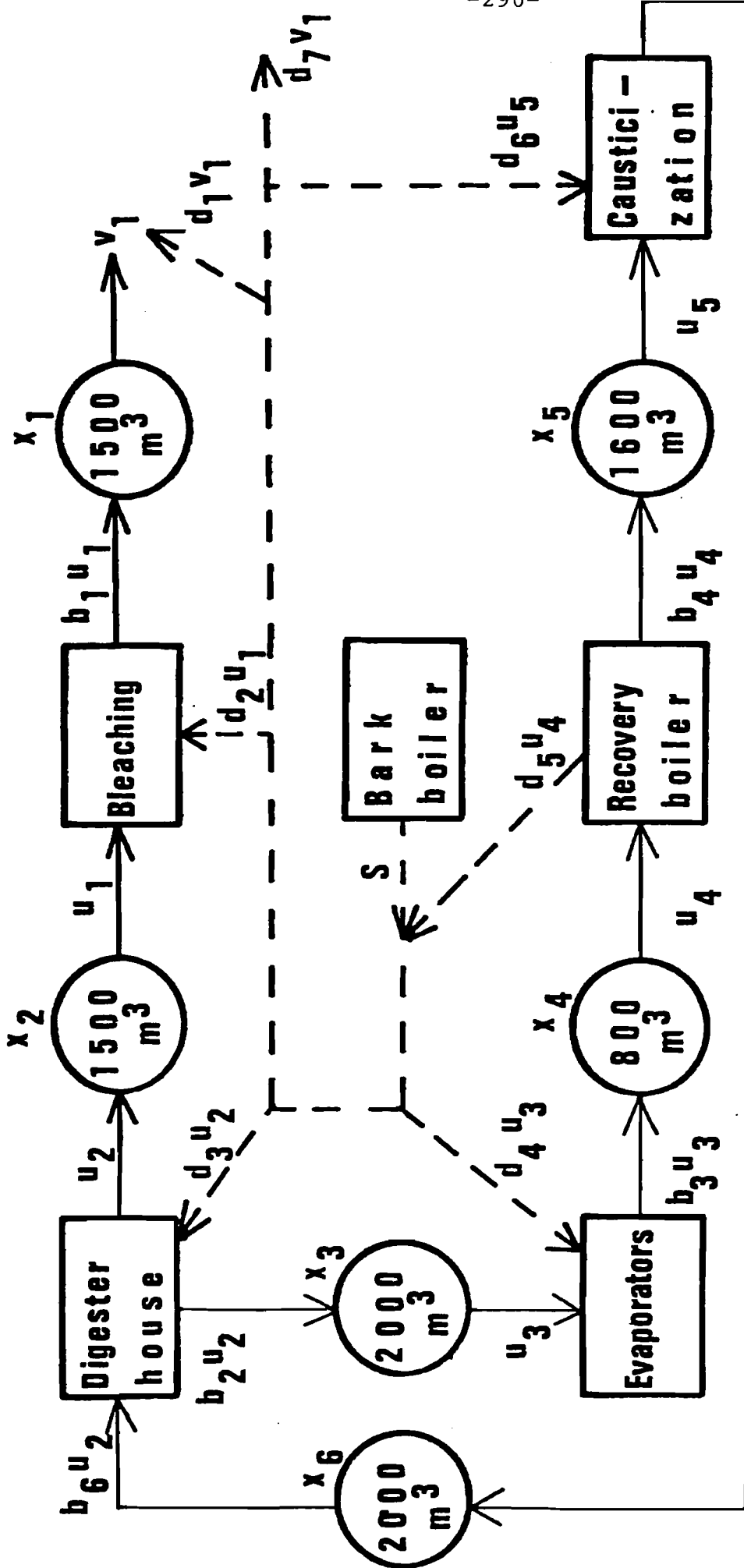

Figure 9. The flow diagram of a pulp mill. The notations for the modelling and the sizes of the storage tanks are also presented.

2. The transfer properties of each process are constant. This means that the process departments use the raw materials and prepare the products always in the same ratio when the same quality is produced.
3. The production schedule of the drying machine is given.

Constant parameter matrices B, C, D and E can be determined by writing-up steady-state material and energy balances for each process. The complete vector-matrix presentation for Equation 1 is shown in Equation 3

$$\frac{d\bar{x}(t)}{dt} = \begin{bmatrix} 0.990 & 0 & 0 & 0 & 0 \\ -1 & 0.961 & 0 & 0 & 0 \\ 0 & 0.9198 & -1 & 0 & 0 \\ 0 & 0 & 0.211 & -1 & 0 \\ 0 & 0 & 0 & 1.9745 & -1 \\ 0 & -0.3333 & 0 & 0 & 0.871 \end{bmatrix} \bar{u}(t) + \begin{bmatrix} -1 \\ 0 \\ 0 \\ 0 \\ 0 \\ 0 \end{bmatrix} v_1(t) \quad (3)$$

Equation 2 yields

$$s(t) = [0.266 \quad 0.5432 \quad 0.478 \quad -8.408 \quad 0] \bar{u}(t) + (0.377+0.490)v_1(t) \quad (4)$$

and

$$\begin{aligned} \bar{x}(t) &= [x_1, x_2, x_3, x_4, x_5, x_6]^T \\ \bar{u}(t) &= [u_1, u_2, u_3, u_4, u_5]^T. \end{aligned} \quad (5)$$

The term  $0.490v_1$  includes the amount of the steam consumed in the generation of the back pressure power and that used for warming up the processing water. These amounts are thus considered proportional to the production rate of pulp.

The calculation of the production schedules for the actual mill is done with some discrete time intervals and therefore in the following the discrete time equivalence of Equations 3...5 is used.

The production rates of the process departments are constrained

$$u_i^{\text{Min}} \leq u_i(k) \leq u_i^{\text{Max}}, k=0,1,\dots,K-1 \quad (6)$$

where  $K$  is the number of the planning intervals. The upper constraints,  $u_i^{\text{Max}}$ , depend on the maximum capacities of the processes and also on the planned shut-downs of the processes. The lower constraints depend on the lowest possible (either economical or constructional) production rates. Here the following numerical values are used (units  $\text{m}^3/\text{h}$ )

$$\begin{cases} \bar{u}^{\text{Max}} = [100,105,100,30,50] \text{ and} \\ \bar{u}^{\text{Min}} = [75,68,63,12.5,25] \end{cases}$$

The capacities of the storage tanks are constrained, too

$$x_i^{\text{Min}} \leq x_i(k) \leq x_i^{\text{Max}}, k=0,1,\dots,K. \quad (7)$$

Here the random disturbances are taken into account so that some part of storage capacity is always reserved in order to compensate these disturbances. In practical situations the size of these reserve capacities must be determined using the disturbance times and the times between the disturbances determined statistically for each process. Here, however, for each storage  $x_i^{\text{Min}}$  is set 20 % and  $x_i^{\text{Max}}$  80 % of the maximal capacity of the storage.

The production rate of the auxiliary boiler is constrained as

$$s^{\text{Min}} \leq s(k) \leq s^{\text{Max}} \quad (8)$$

Here the values  $s^{\text{Min}} = 20 \text{ GJ/h}$  and  $s^{\text{Max}} = 80 \text{ GJ/h}$  are used.

#### TARGETS OF PRODUCTION CONTROL

Production control aims at coordinating efficiently the operation of processes thus minimizing the costs of production. Energy consumption, energy generation and the

actual production may have separate targets. The realization of these targets leads, however, to same results: undisturbed production results in even energy consumption and thus in even energy generation, too.

Following requirements must be taken into consideration, when the production scheduling procedure is defined:

1. The planned pulp production schedule must be realized.
2. Quality disturbances are avoided by avoiding production rate changes.
3. Planned shut-downs must be included in the scheduling in advance.
4. Random disturbances must be taken into account.
5. The production rate of bottleneck processes must be maximized.
6. Storage tanks must not be empty or flow over.
7. Storage capacity must be efficiently utilized.
8. Appropriate target levels of the storage tanks at the end of the scheduling period must be assured. This facilitates the scheduling during the next period.
9. Liquor and chemicals must be in balance.
10. Process delays must be taken into consideration.
11. Consumption and generation of energy (the steam) must be balanced.
12. The production of the auxiliary boiler must be maximized.
13. In the auxiliary boiler the bark burning must be maximized (thus replacing oil in oil boilers).
14. The operation and the steam generation capacity of the recovery boiler is closely connected to the operation of the chemical recovery cycle. It cannot be used to compensate short-term disturbances in the steam consumption.
15. The indirect storing of the steam in pulp or in black liquor must be possible.

It is difficult to put all these requirements into mathematical form without increasing the size and complexity of the scheduling problem. It is anyway possible to take them into account, either directly or indirectly, using the simple modelling approach presented before. It must be emphasized that it is not necessary to include all these requirements into the objective function. For instance, random disturbances can be taken into account by selecting suitable target levels and appropriate maximum and minimum constraints for the storage tanks.

The overall target of the production control is to maximize the net profit. This can be done either by selecting the net profit function as a performance function (Golemanov, 1972, Golemanov and Koivula, 1973, Tinnis, 1974) or by minimizing the number of production rate changes (Petterson, 1969, 1970 a, Leiviskä and Uronen, 1979 a).

## SOLUTION METHODS

### Tamura's algorithm

The application of Tamura's time delay algorithm to the optimization of process-storage systems has been considered previously (Leiviskä and Uronen, 1979 a,b). The mathematical formulation is presented in the previous papers, too. Basically, this algorithm solves the decomposed maximum principle problem. A linear quadratic objective function is used

$$J = \frac{1}{2} \left\{ \left\| \bar{x}(K) - \bar{x}^0(K) \right\|_{Q(K)}^2 + \sum_{k=0}^{K-1} \left[ \left\| \bar{x}(k) - \bar{x}^0(k) \right\|_{Q(k)}^2 + \left\| \bar{u}(k) - \bar{u}^0 \right\|_{R(k)}^2 \right] \right\} \quad (9)$$

where  $\left\| \bar{x} \right\|_Q^2 = \bar{x}^T Q \bar{x}$ . The values of  $\bar{x}^0(k)$  can be determined

so that they are statistically the most advantageous as for the unplanned shut-downs (Edlund and Kalmen, 1974).

Here the 50 % percent value for all the intermediary storages is used.

For the values of  $u_i^0$  we can write

$$\begin{cases} u_1^0 = [\gamma_1 \sum_{k=0}^{K-1} v_1(k)]/K \\ u_i^0 = \gamma_i u_{i-1}^0; \quad i=2,3,\dots \end{cases} \quad (10)$$

Constants  $\gamma$  can be determined using material balances.

The optimization problem is now

$$\begin{aligned} \text{Min } J, \text{ when} \\ \bar{x}, \bar{u} \end{aligned} \quad (11)$$

$\bar{x}(0) = \bar{x}_0$  and the Equations 3...8 are satisfied.

According to Fig. 4 Tamura's algorithm can be described by two-level formulation. In this case only one variable algebraic equations on the lowest level are considered.

### Simulation approach

When simulation methods are used in production control the greatest difficulty is in obtaining adequate a priori information so that the best possible production schedule can be obtained. Of course, one can start with an arbitrary production schedule. If all the constraints are fulfilled a feasible production schedule is obtained. If not, another schedule is applied until a feasible solution is obtained. This approach has following features:

1. A feasible production schedule can easily be obtained, if the user is experienced in the production control of the mill in question.

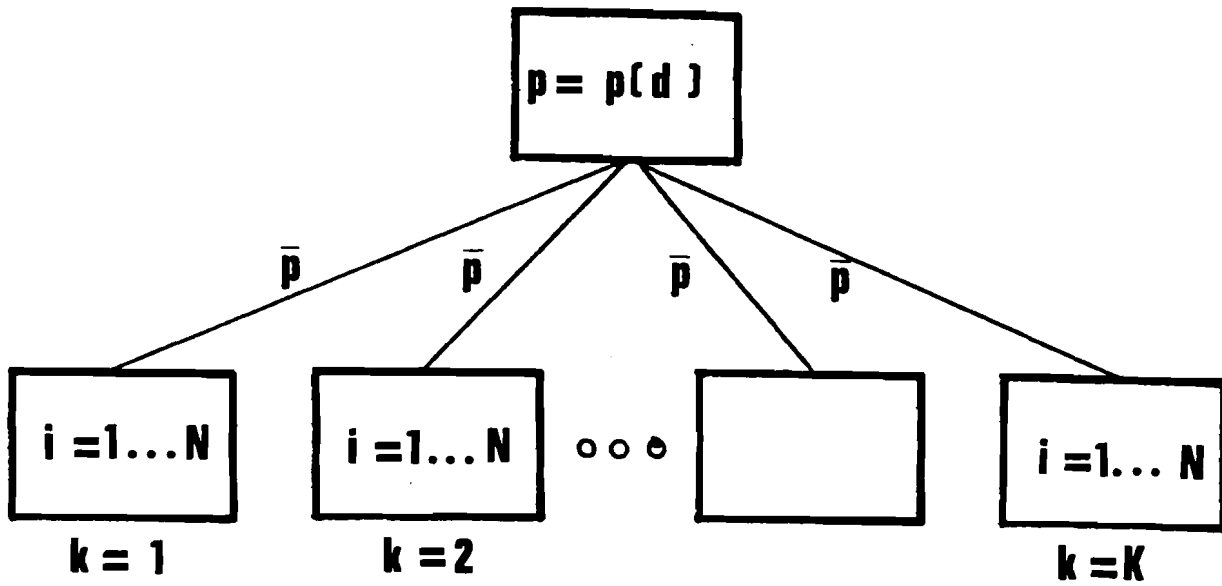

Figure 4. Hierarchical formulation of Tamura's time delay algorithm.



2. The solution is, in no way, optimal, only feasible.
3. If there are many alternatives to be simulated, the amount of manual work increases very much.

Using a logical, heuristic algorithm instead of manual methods, the efficiency of the pure simulation approach is improved. Of course, a lot of experience is required in order to develop this kind of algorithm.

The simulation program package was formulated hierarchically according to Fig. 5. The hierarchical structure was selected in order to describe clearly the information flow inside the simulation system. The program package consists, in principle, of three separate blocks:

1. Production rate calculation block
2. Energy balance calculation block
3. Print-out block.

The functions of different programs are:

PCSUPR	The main program
PCPROD	The subroutine. The coordination program for production rate calculation
PCMODU	The subroutine. Determines the production schedule of a certain process department according to the constraints set by a certain intermediary storage
PCSIM1	The subroutine. Calculates the levels of the intermediary storages and shows the possible breaking-up of the constraints
PCFRCE	The subroutine. Checks the production rates
PCSTOP	The subroutine. Carries out the shut-down of a certain process
PCSCH1	The subroutine. Determines the initial production schedules based on the required production schedules of pulp and paper
PCSIM2	The subroutine. Calculates the total need of energy for the whole mill and the corresponding generation of the electric power

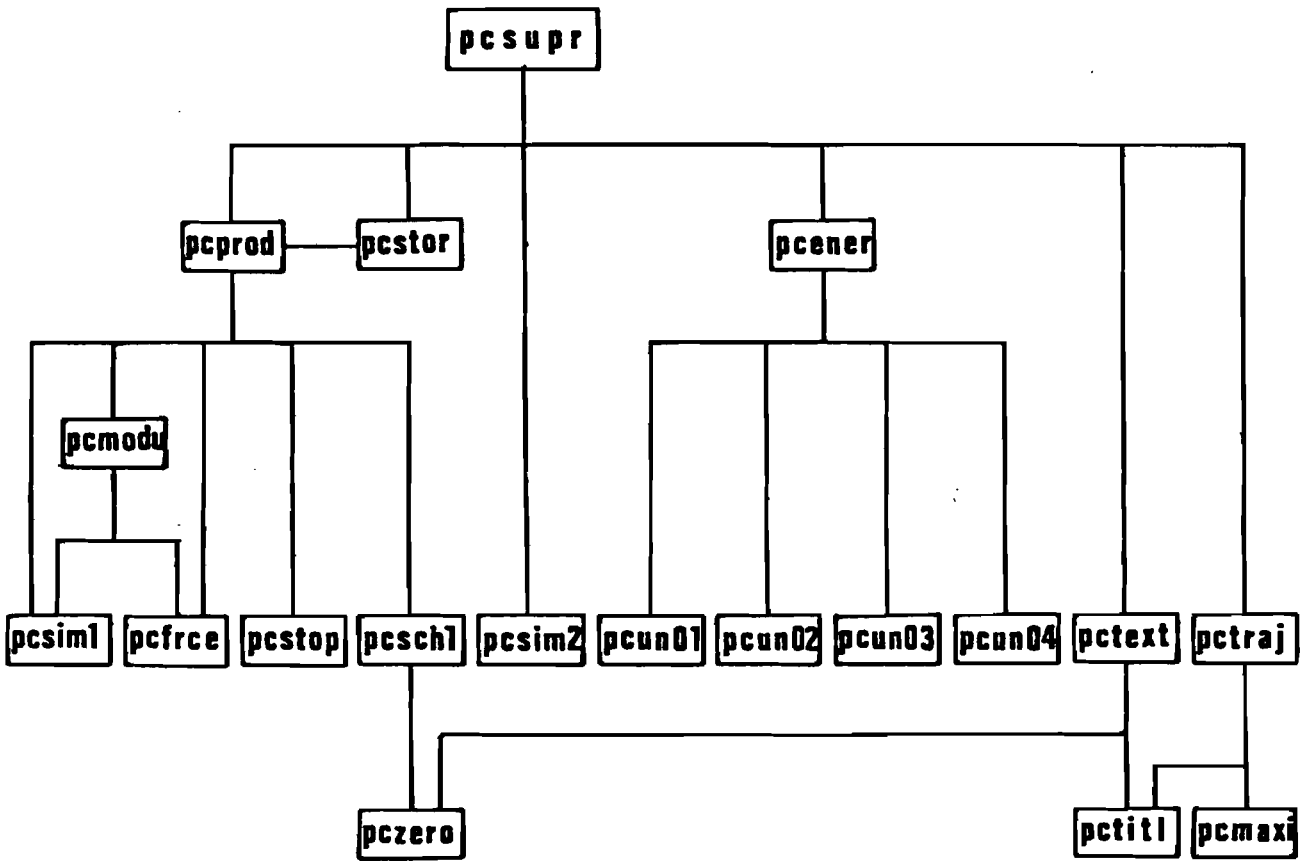

Figure 5. The simulation program package.

PCENER	The subroutine. The coordination program for the energy balance calculations
PCUNØ1...	Subroutines. Calculate the generation of energy by the recovery boiler, the power boiler and the amount of energy to be bought
PCUNØ4	
PCSTOR	The subroutine. Considers the indirect storing of the steam
PCTEXT	The subroutine. Print-out as tables
PCTRAJ	The subroutine. Print-out the trajectories of all variables to be considered
PCTITL	The subroutine. Finds out the titles for different print-out options
PCZERO	The subroutine. Sets the elements of a certain vector to zero
PCMAXI	The subroutine. Finds out the greatest element of a given vector.

The most important programs are PCPROD and PCMODU. PCPROD forms the decision to change the production rate of a certain process department. Correspondingly, this new production rate is calculated in PCMODU.

More detailed information is presented elsewhere (Leiviskä et al., 1980).

#### Network flow algorithm

Linear programming can be used if the problem is deterministic and both the constraints and the objective function are linear. The capacity constraints in Equation 6 vary in fact stochastically and therefore some risk is included if a deterministic system is used. The random disturbances can, however, be eliminated by selecting proper storage tank levels. This means that enough reserve capacity is left so that the major random disturbances can be damped without changing the calculated production schedules.

Now the following objective function can be used

$$\min J = \sum_{i=1}^5 c_i \sum_{k=1}^K |u_{i,k} - u_{i,k-1}| \quad (12)$$

costs of production rate changes

$$+ \sum_{j=1}^6 h_j \sum_{k=1}^K |x_{j,k} - x_j^{\text{opt},k}|.$$

costs of deviations from the  
desired reference levels of the  
storage tanks

In Equation 12  $c_i$  is the cost per unit caused by the production rate change in the process  $i$ ,  $h_j$  is the cost per unit caused by the deviation from the desired reference level of the storage tank  $j$ ,  $x_j^{\text{opt},k}$ . This reference level for each interval  $k$  is determined keeping the random disturbances in mind. Empty or full storages are not allowed. They are included in the constraints, but omitted in the objective function.

The objective function in Equation 12 must be linearized. This can be done by introducing new variables

$$\begin{aligned} u'_{i,k} &\geq 0 & x'_{j,k} &\geq 0 \\ u''_{i,k} &\geq 0 & x''_{j,k} &\geq 0 \end{aligned} \quad (13)$$

and the corresponding constraints

$$\begin{aligned} u'_{i,k} &\geq u_{i,k} - u_{i,k-1} \\ u''_{i,k} &\geq u_{i,k-1} - u_{i,k} \\ x'_{j,k} &\geq x_{j,k} - x_j^{\text{opt},k} \\ x''_{j,k} &\geq x_j^{\text{opt},k} - x_{j,k} \end{aligned} \quad (14)$$

Now the objective function is

$$\begin{aligned} \min J = & \sum_{i=1}^5 c_i \sum_{k=1}^K u'_{i,k} + \sum_{i=1}^5 c_i \sum_{k=1}^K u''_{i,k} \\ & + \sum_{j=1}^6 h_j \sum_{k=1}^K x'_{j,k} + \sum_{j=1}^6 h_j \sum_{k=1}^K x''_{j,k} \end{aligned} \quad (15)$$

The production scheduling problem of the pulp mill in Fig. 3 is solved using a standard Ford-Fulkerson 'out-of-kilter' algorithm (Ford and Fulkerson, 1962). This algorithm is a network flow algorithm and therefore the original problem must be formulated as a network flow problem. In comparison with a conventional LP-problem the network flow problem can be solved with a smaller computer memory capacity in shorter execution time. In this case this formulation corresponds also very closely the physical system, namely the actual material flows in the mill.

Figure 6 shows a small part of the network of the pulp mill considered. Now the branches in the network have certain costs and upper and lower capacity constraints. The problem is to find the optimal route through the network in order to produce the required pulp production.

#### COMPARISON OF THE SOLUTION METHODS

The performance of the before mentioned approaches was compared using simulations with UNIVAC 1100/20-computer of the University of Oulu. The scheduling period was 2 days. It was divided into six scheduling intervals, 8 hours each.

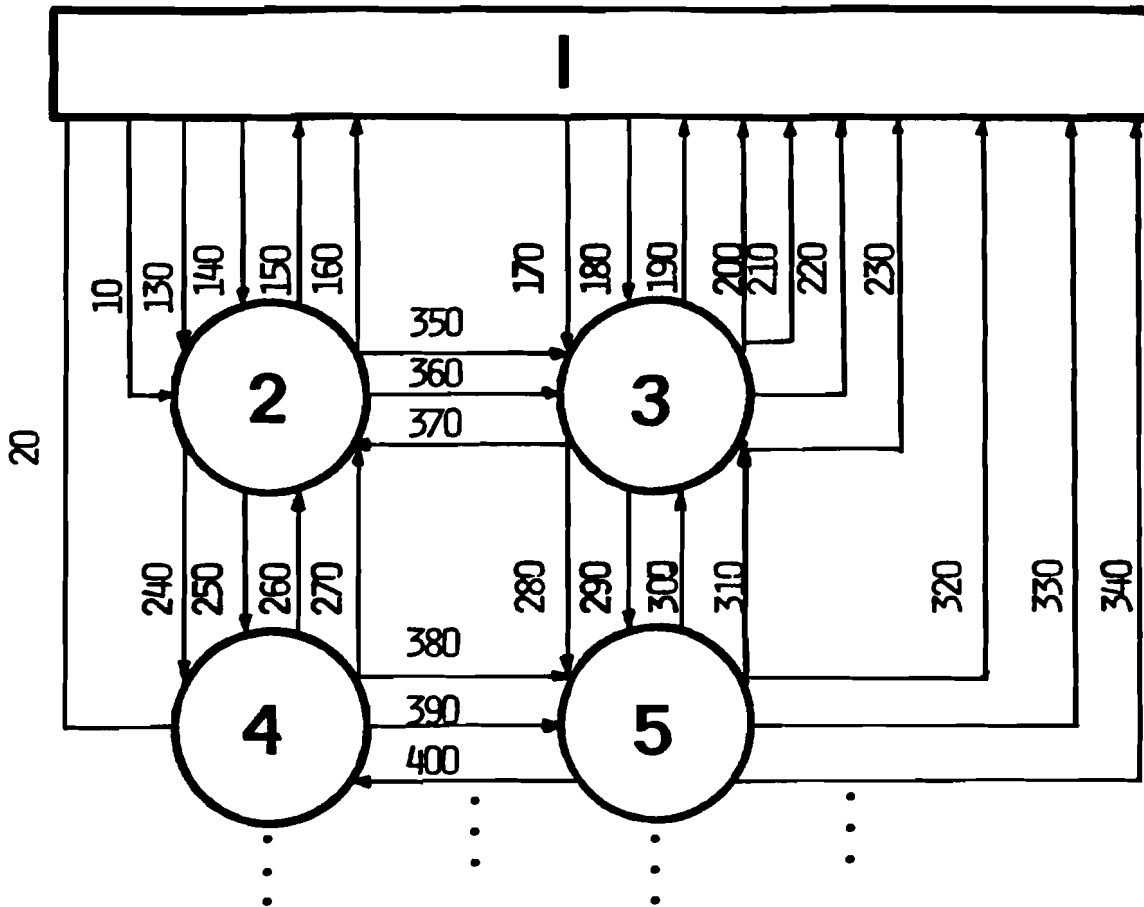

Figure 6. An example of network presentation.

- Legend:
- Branches 130-160 are for the digester house during the first planning interval: 130 for optimal production 140, 150 for productions smaller and greater than optimal production and 160 is the loss branch.
  - Branches 170-200 are for the digester house during the second planning interval.
  - Branches 240-310 are for the bleach plant.
  - Branches 10 and 20 are the initial states of the storage tanks.
  - Branches 350-370 are for the storage tank  $x_2$ : 350 for optimal level and 360 and 370 for levels smaller and greater than the optimal level.

Here only two planning intervals are considered.

COMPARISON

	SIMULATION	TAMURA'S ALGORITHM	OUT-OF-KILTER ALG.
Execution times	Short +	Short +	Longer -
Memory requirements	Small	Moderate	Moderate
Performance	No criteria, but gives fewer production rate changes than other methods +	(g) can be adjusted by the weighting factors	(12) →
Programmability	Lot of work needed- - (heuristics, testing)	Easy +	Easy +
Program transfer-ability to different plants	Only few standard - parts; solution cannot be guaranteed	Standard package +	Standard package +
User-orientation	Easy to understand	Standard package →	Formulation corresponds to mill structure
Updating in on-line application	Model update and heuristics in some cases -	Model update	Model update

LITERATURE

1. Alsholm O., Petterson B., (1970). Integration of pulp mill control with the production planning of a paper mill. Paper making systems and their control. Transactions of the Symposium, Oxford 1969. The British Paper and Board Maker's Association (Inc.). London. p. 209...231.
2. Chalaye G., Foulard C., (1976). Hierarchical control of a pulp mill. Proceedings of 3rd Int. IFAC Conference on Instrumentation and Automation in the Paper, Rubber and Plastic Industries. Brussels, 24-26. May, p.109...119.
3. Edlund S.G., Johansson R., (1977). Experiences with a multiple unit production control system for the optimization of mill operations. Preprints, International Symposium on Process Control, CPPA, Vancouver, B.C., p. 36...39.
4. Edlund S.G., Kallmén C., (1974). Production control in pulp and paper mills. British Paper and Board Federation, International Symposium, Kent, 11 p.
5. Edlund S.G., Rigerl K-H., (1978). A Computer-based production control system for the coordination of operation in a pulp and paper mill. Proceedings of the 7th Triennial IFAC World Congress. Helsinki. p. 221...227.
6. Ford L.R., Fulkerson D.R., (1962). Flow in Networks. Princeton University.
7. Golemanov L.A., (1972). Systems theoretical approach in the projecting and control of industrial production systems. EKONO. Helsinki. 80 p.



8. Golemanov L.A., Blomberg H., (1973). Dimensioning of storage facilities and optimization of control strategy. Tappi 56, 1, p. 109...112.
9. Golemanov L.A., Koivula E., (1973). Optimal production control and mathematical programming. Paperi ja Puu 55, 2, p. 53...67.
10. Leiviskä K., (1979). Comparison of optimal and suboptimal methods for pulp mill production control. 9th IFIP Conference on Optimization Techniques. Warszawa, Sept. 4-8.
11. Leiviskä K., Komokallio H., Aurasmaa H., Uronen P., (1980). Heuristic algorithm for production control of an integrated pulp and paper mill. To be presented in 2nd Symposium Large Scale Systems Theory and Applications. Toulouse, June 25...27.
12. Leiviskä K., Uronen P., (1979 a). Dynamic optimization of a sulphate mill pulp line. Preprints of IFAC/IFORS Symposium, Toulouse, France, March 1979, p. 25...32.
13. Leiviskä K., Uronen P., (1979 b). Hierarchical control of an integrated pulp and paper mill. Report 113. Purdue Laboratory for Applied Industrial Control, Purdue University, West Lafayette, Indiana. 109 p.
14. Petterson B., (1969). Production control of a complex integrated pulp and paper mill. Tappi 52, 11, p. 2155...2159.
15. Petterson B., (1970 a). Mathematical methods of a pulp and paper mill scheduling problem. Report 7001. Lund Institute of Technology, Division of Automatic Control. Lund. 70 p.
16. Petterson B., (1970 b). Production control of a pulp and paper mill. Report 7007. Lund Institute of Technology, Division of Automatic Control. Lund. 27 p.

17. Petterson B., (1970 c). Optimal production schemes coordinating subprocesses in a complex integrated pulp and paper mill. Pulp and Paper Magazine of Canada 71, 5, p. 59...63.
  
18. Tinnis V., (1974). An optimum production control system. Pulp and Paper Magazine of Canada 75, 7, p. 84...88.

APPENDIX

## FOREST INDUSTRY - ISSUES FOR THE EIGHTIES

Notes of a meeting of the use of systems analysis in the Forest Industry held at IIASA

### 1. Purpose of Meeting

The purpose of the meeting was for representatives of the Forestry and Forest Products Industries, together with associated research workers, to meet to discuss the present state of the art of system analysis in the Industry, and to consider proposals prepared by IIASA to initiate a joint collaborative study under the general title - Issues for the Eighties.

### 2. General Background

The original proposal that IIASA should undertake a study in the Forest Industries was first proposed by Finnish representatives in 1978, and was incorporated into research plan for the Institute for 1979. General proposals were drawn up at a small task force meeting with representatives from Canada, Sweden and Finland in July, 1979, and subsequent discussions had been held in the Nordic countries, N. America and the U.S.S.R. The general proposal was in the form of a collaborative study - to be undertaken in individual countries as well as at IIASA - to identify the main problems facing the industry in the 1980's, to explore where system analysis might help, to identify the state of the art and undertake a critical comparative analysis of the tools available, and finally to agree on a coordinated research plan. Details of IIASA's proposals are set out in the Annex to these notes, Paper FN/1 and FN/2.

The meeting was attended by 40 participants from 12 countries: Canada, United Kingdom, USA, Netherlands, Austria, Sweden, Hungary, Finland, USSR Japan, BRD and Norway. The agenda and list of participants are also included in the Annex. The basic design was to start with general discussions on problems and the possibilities of cooperation, and then to continue with more technical discussions of particular models. Many of the industry representatives however stayed throughout the meeting, and the wide range of models being applied in the industry in different countries showed that the potential impact of systems analysis was wider than most people had imagined.

The purpose of these notes is to review the main items discussed, and to indicate the general conclusions. (Copies of relevant papers can be obtained from IIASA at cost.) A program of work is now being developed by the Management and Technology Area at IIASA, and interested persons should contact the Area Chairman.

3. Survey of problems and structural changes in the Forest Industry in different countries.

The first working session included the keynote address by Mr. P. Rautalahti, President of Veitsiluoto Co. Kemi, Finland, and a survey on actual problems and structural changes in the next 10-15 years by industrial speakers from following countries:

- |        |   |  |
|--------|---|--|
| Canada | : | Dr. K.M. Thompson<br>Pulp and Paper Research Institute<br>of Canada<br>Pointe Claire.  |
| USA    | : | Dr. P.E. Wrist<br>Vice President--Technology<br>The Mead Corporation,<br>Dayton, Ohio.   |
| USSR   | : | Dr. A. Iakunin<br>Director<br>The USSR All-Union Research &<br>Design Institute on Economics,<br>Production Management &<br>Information of Forestry,<br>Pulp & Paper, & Wood-Working<br>of the USSR Forest & Wood-<br>Working Ministry,<br>Moscow. |
| Sweden | : | Dr. B. Holmberg<br>AB Statens Skogsindustrier (ASSI)<br>Stockholm.   |

Japan : Dr. S.T. Konari  
Corporate Planning Division  
Jujo Paper Company Limited  
Tokyo.

UK : Mr. A. Grayson  
Chief Economist  
Forestry Commission  
Edinburgh

Austria : Dipl. Ing. Dr. O. Eckmüller  
Universität für Bodenkultur  
Wien.

Developing Countries : Prof. Dr. D. Noack  
: Universität Hamburg und Bundes-  
forschungsanstalt für Forst-  
und Holzwirtschaft  
Hamburg.

In addition to this, Mr. J. Kettunen, R&D Director, Metsäliiton Teollisuus Co., Kirkniemi, Finland, shortly presented a list of possible research topics, with priorities, proposed by the Finnish Forest Industry (Appendix 1).



Prof. Ake Andersson (IIASA/Sweden) prepared a summary of the main problems referred to in these discussions (Table 1). He also discussed the development trends and importance of the forest industry in national economies in various countries.

From this summary and the subsequent discussion, the following conclusions emerged:

- Most of the issues listed are recognized in all countries but their importance and priorities varied, depending on the "basis" of the industry (import based; Japan, UK, or exporting countries Canada, Finland, Sweden).
- The changing price and availability of energy could have a major impact on the patterns of production in the industry.
- The international and global effects and trends including the changes in monetary exchange rates were given much emphasis.
- In general the questions relating demand and supply, costs and efficiency are critical.
- The cyclicity of business and of investment were important factors, as was its high capital intensiveness. The forest industry is very slow in innovation and R&D. The question is not so much about getting money in good projects but merely how to organize and plan the R&D work and how to gain momentum in innovation work.

A. ANDERSSON, IIASA

TABLE 1: Issues Discussed by Different Participants at the IIASA Forestry Workshop, January 8-11, 1980

	RAW MATERIAL	ENERGY	CAPITAL	LABOR	HUMAN CAPITAL	OTHER ISSUES		
						ENVIRONMENT	TECHNOLOGY	MARKETS/ PRODUCTS
AUSTRIA	Balanced Utilization "Many Users"	Conversion to Energy Forests?						
CANADA	From Mining to Management Multi-objective Forestry Policies	Energy Cost Sensitivity of Process and Products	Availability; Modernization; Taxation	Costs and Supply for Forestry Regional Issue	Restructuring in Forest Industry Regions	Pollution Abatement Tourism-Recr. Forestry Forest Industry	R & D in Forest Industry Support?	World Market Forecasts Currency Problems Protection Transportation Competitiveness
DEVELOPING COUNTRIES	From Selective Mining to Plantation Management Rare Species	Dependence on Wood for Energy Prod. Increase?	Investment Scarcity versus High Capital Intensity	Labor Intensive Technology Needed	Obvious Problems	Heterogeneous Forests with Unusual Trees	Small-scale Labor-intensive Technology Needed	Local Versus World Demand Balance of Trade
FINLAND	Availability	Generally Energy Intensive Sector	High Capital Intensity, Specialization of National Importance	Include	Include	Economy versus Environment in Forestry	Automation Computerization	World Market Industry i.e. Include all Countries in a Bilaterally Specified Trade Analysis
JAPAN	Import Strategies	Transportation Cost Effects	Comparative Investment Productivity?	Scarcity of "Wood Workers"		Water Availability	"Moderate" Industrial Complexes	Trade Analysis Needed Demand Saturation for Wood Paper Products?
SWEDEN	Biological vs Economic Optimality: Regional Variation	"Sawing -Pulping -Burning" Proportions	"Competitiveness Productivity-Investments"	Regional Employment Policy vs Productive Industry & Growth		See Canada and Finland Labor Environment	--	Optimal Adaption of Product Mix to Demand Development. Good Forecasts of Demand or Mobility of Resources?
UK	Forestry vs Farming Recreation Land Use			Regional Aspects of Forestry Policies		Land Use Policies	--	Product Prices in World Market Cartels? Product Substitution with Electronics, Plastics, Metals, etc.
USA	Availability Costs; Productivity Growth	Availability Prices "Fuel-Fiber"	Availability, Scale, Durability Decis. Possibility	See 		Forestry Chemicals Manufacturing Pollution	1. Costs - Rev. of New Pro. Control Tech. 2. Packaging Tech. 3. Chipping 4. Computerization	Product Use Product Design for Resources-Limitation Economy
USSR	Better Managem. Methods ..... Utiliz. of Bio-mass		Mechanization	Training Policies Social Conditions 		Env. Problems of New Harvesting and Prod. Techniques	Industrial Complex Analysis	Optimal Transportation Analysis

- Regional effects of forest industry were also recognized by many speakers.
- In the longer term the ultimate question will be, what is the "optimal" usage of the forest biomass; the balance between burning (energy), sawing (mechanical wood industry), pulping (paper production) and other usages. Other usages include a.o. recreational usage, wilderness, forage and watershed. Closely connected with this balanced multi-usage of forests are many environmental effects (climate effects, effects on land and water, effects of heavy plantation in the ecology etc). For most regions the question here is: how to change from forest mining to forest management.

#### 4. International Collaborative Project.

IIASA's provisional project proposals were discussed at length. In general, the value of such a study, organized in this way, was accepted. All participants felt that IIASA had a valuable contribution to make and hoped that work at IIASA would be continued. The establishment of national reference groups in the individual countries was clearly important but would need delicate negotiation in some countries. This would take a little time. The research topics generally interesting and suitable for IIASA suggested by most speakers can be listed as follows:

##### i) Methodology

- surveys on existing and ongoing research and applications concerning systems analysis in the forest sector,
- critical review and study of applicability of the existing models,
- development of methodology for evaluating the economical impacts of different governmental and other regulations.

##### ii) Studies on international trade

- world trade modeling,
- effects of changes in monetary system, tariffs etc.

##### iii) Technological change

- innovation
- computerization
- risk and uncertainty
- studies on integrated organizations.



- iv) Regional and National aspects
- cyclical character of the business
- investment consequences

Swedish and Finnish national projects have already been established and they were shortly reported and discussed. In Finland a 3 years project has just started concerning hierarchical production planning and management information systems in the forest industry. The small-scale computer study at IIASA is relevant to this work and close cooperation between those studies is anticipated. In addition to this, a project concerning the modeling of the Finnish forest sector has now been almost completed. This project has also had a direct link and continuation at IIASA. In Sweden a project studying regional effects of the forest industry and regionalization of the forest sector models is now in its planning stage. The participants from the US and Canada a.o. urged the needs for organizing the national projects and support to IIASA. Dr. Iakunin of USSR stated that the biggest interest in his country is a review of available models, in technological change and in studies of industrial complexes.

#### 5. Technical Sessions

The four technical sessions were:

- "Modeling of world market and global aspects",
- "National and Regional Modeling of the Forest Sector",
- "Forest Management" and
- "Management Systems in the Forest Industry".

Most of the papers presented in these sessions were distributed to the participants before or during the workshop. List of the papers available is on Appendix 2.

#### 6. Summary and Conclusions

The summing up of the workshop was done by Mr. Les Reed, President of F.L.C. Reed & Associates Ltd., Vancouver, Canada and his summary is enclosed as Appendix 3. In summary and final discussion the following conclusions were reached:

- i) The workshop was useful and successful. IIASA is doing relevant work in this area and it has an important part to play in the exchange of information and international collaboration.

- ii) There was general support for an international collaborative project. The start-up of national projects, and the collection of additional funding for new work at IIASA, would take several months to organise, so it was unlikely that a major study of world trade could be mounted until 1981. Recruitment for such a task would need to start in mid 1980.
- iii) Meanwhile IIASA would continue its existing work, concentrating on
  - continuation of survey studies;
  - critical review of the existing forest sector models and their applicability. A seminar (lasting 1 or 2 weeks) for model specialists would be organized at the end of 1980,
  - the relevance of existing work on innovation, computerization, risk, and regional studies to the Forest Industry would be further explored.
- iv) Interested member countries should organize their national studies and reference groups as soon as possible with priorities and timing for the projects.
- vi) IIASA was a suitable centre for further workshops and conferences.
- vii) The time schedule for the international collaborative project at first stage will be 2/3 years.

Management and Technology Area  
February 1980

P. Uronen  
R. Tomlinson

/js

ANNEX TO FN/3.

Agenda of the Workshop, Jan. 8-11, 1980

List of participants

Discussion paper FN/1

Discussion paper FN/2

LIST OF PARTICIPANTS

Forest Industry Workshop, January 8-11, 1980

Wodak Room, IIASA, Laxenburg, Austria

Dr. K. AIRD  
Pulp and Paper Research Institute  
of Canada  
570 St. Johns Boulevard  
Pointe Claire P.Q.  
Canada H9R 3J9

Dipl. Ing. Dr. O. ECKMÜLLNER  
Universität für Bodenkultur  
Gregor Mendelstrasse 33  
1160 Wien  
Austria

Dr. P. BACON  
Institute of Terrestrial Ecology  
Merlewood Research Station  
Grange-over-Sands  
Lancashire LA11 6JU  
United Kingdom

Dr. L. EINARSON  
Swedish Forest Products Research  
Laboratory  
Box 5604  
S-11486 Stockholm  
Sweden

Professor C.S. BINKLEY  
School of Forestry and Environmental  
Studies  
Yale University  
205 Prospect Street  
New Haven, CT 06511  
USA

Mr. I. GONDOCS  
Office for Forestry and Forest  
Industries  
Hungary

Ir. A. DE WIT  
Research Institute for Forestry and  
Landscape Planning  
Bosrandweg 20  
6704 PH Wageningen  
Netherlands

Mr. A. GRAYSON  
Chief Economist  
Forestry Commission  
231 Corstorphine Road  
Edinburgh  
United Kingdom

Dr. P.E. DRESS  
School of Forest Resources  
University of Georgia  
Athens  
Georgia 30602  
USA

Dr. S. HEIKKILÄ  
Managing Director  
Dataway Oy  
Lönrotinkatu 17  
P.O. Box 874  
SF-00101 Helsinki 10  
Finland

Dr. D.P. DYKSTRA  
School of Forestry and Environmental  
Studies  
Yale University  
205 Prospect Street  
New Haven, CT 06511  
USA

Dr. B. HOLMBERG  
c/o The Swedish Committee for  
Systems Analysis  
FRN  
Fack  
S-10310 Stockholm  
Sweden

Dr. L. HULTKRANTZ  
The Economic Research Institute  
Stockholm School of Economics  
Box 6501  
S-11383 Stockholm  
Sweden

Dr. A. IAKUNIN  
Director  
The USSR All-Union Research & Design  
Institute on Economics, Production  
Management & Information of  
Forestry, Pulp & Paper, & Wood-  
Working of the USSR Forest & Wood-  
Working Ministry  
Polkovaia ulitsa 17  
127018 Moscow  
USSR

Dr. A. ISAEV  
Director  
Institute of Forestry  
Krasnojarsk  
USSR

Dipl. Ing. K.M. JEGR  
Pulp and Paper Research Institute  
of Canada  
570 St. Johns Boulevard  
Pointe Claire, P.Q.  
Canada

Dr. B. JOHANSSON  
c/o The Swedish Committee for  
Systems Analysis  
FRN  
Fack  
S-10310 Stockholm  
Sweden

Dr. E. JUTILA  
University of Oulu  
Department of Process Engineering  
Linnanmaa  
SF-90570 Oulu 57  
Finland

Dr. A. KARLQVIST  
The Swedish Committee for Systems  
Analysis  
FRN  
Fack  
S-10310 Stockholm  
Sweden

Mr. J. KETTUNEN  
R&D Director  
Metsäliiton Teollisuus Oy  
SF-08800 Kirkniemi  
Finland

Mr. S.T. KONARI  
Corporate Planning Division  
Jujo Paper Company Limited  
1-12-1 Yuraku-cho  
Chiyoda-ku  
Tokyo  
Japan

Mrs. KECSKEES  
Office for Forestry and Forest  
Industries

Mr. K. LEIVISKÄ  
University of Oulu  
Department of Process Engineering  
Linnanmaa  
SF-90570 Oulu 57  
Finland

Dr. L. LÖNNSTEDT  
Department of Economics  
Swedish Institute of Forestry  
(Skogshogskolan)  
Umea  
Sweden

Mrs. MOSKALENKA  
c/o Committee for Systems Analysis  
Presidium of the Academy of Sciences  
of the USSR  
29 Ryleyev Street  
Moscow 119034  
USSR

Dr. S. NILSSON  
c/o The Swedish Committee for  
Systems Analysis  
FRN  
Fack  
S-10310 Stockholm  
Sweden

Prof. Dr. D. NOACK  
Universität Hamburg und Bundes-  
forschungsanstalt für Forst- und  
Holzwirtschaft  
Leuschnerstrasse 91  
D-2050 Hamburg 80  
BRD

Ing. R. SMITS  
Netherlands Organization for Applied  
Scientific Research (TNO)  
Staffgroup Strategic Surveys and  
Systems Analysis Group  
Laan van Westeneuk 501  
Apeldoorn 7334 DT  
Netherlands

Mr. P. RAUTALAHTI  
Managing Director  
Veitsiluoto Oy  
Fredrikinkatu 61  
SF-00100 Helsinki 10  
Finland

Dr. B. SOLBERG  
Institute of Forest Economics  
Agricultural University of Norway  
P.O. Box 44  
N-1430 As-NLH  
Norway

Mr. F.L.C. REED  
President  
F.L.C. Reed & Associates Limited  
Consulting Economists  
1847 West Broadway  
Vancouver, B.C.  
Canada V6J 1Y6

Dr. K.M. THOMPSON  
Pulp and Paper Research Institute  
of Canada  
570 St. Johns Boulevard  
Pointe Claire, P.Q.  
Canada H9R 4B5

Dr. C. ROW  
Leader  
Evaluation Methods Research Group  
US Department of Agriculture  
Forest Service  
P.O. Box 2417  
Washington, D.C. 20013  
USA

Dr. S. UHLIN  
c/o The Swedish Committee for Systems  
Analysis  
FRN  
Fack  
S-10310 Stockholm  
Sweden

Prof. Dr. H. SCHULZ  
Institut für Holzforschung der  
Universität  
Winzererstrasse 45  
D-8000 München 40  
BRD

Mr. M. WAUMSLEY  
Highlands and Islands Development  
Board  
Bridge House  
Bank Street  
Inverness  
United Kingdom

Prof. R. SEPPÄLÄ  
c/o Resource Policy Center  
Dartmouth College  
8000 Hinman  
Hanover, NH 03755  
USA

Dr. D. WILSON  
Canadian Pulp and Paper Association  
Montreal  
Canada

Mr. S. SIERILÄ  
Director  
Central Association of Finnish  
Forest Industries  
Eteläesplanadi 2  
SF-00130 Helsinki 13  
Finland

Dr. P.E. WRIST  
Vice President--Technology  
The Mead Corporation  
Courthouse Plaza Northeast  
Dayton, Ohio 45463  
USA

IIASA Participation

Dr. R. LEVIEN	-- Director
Mr. R. TOMLINSON	-- Area Chairman, Management and Technology
Dr. A. WIERZBICKI	-- Area Chairman, System and Decision Sciences
Dr. M. ALBEGOV	-- Head of Department, Integrated Regional Development
Dr. P. URONEN	-- Management and Technology
Dr. A. ANDERSSON	-- Integrated Regional Development
Dr. G. FICK	-- Management and Technology
Dr. V. GLAGOLEV	-- Management and Technology
Dr. D. NYHUS	-- System and Decision Sciences
Dr. M. KALLIO	-- System and Decision Sciences

AGENDA

Forest Industry Workshop, January 8-11, 1980

Wodak Room, IIASA, Laxenburg, Austria

Tuesday, January 8

Chairman: R. Tomlinson, IIASA

GENERAL PART

- |       |   |                                      |
|-------|---|--------------------------------------|
| 8.45  | Registration  |                                      |
| 9.00  | Opening and Welcome to IIASA  | R. Levien, IIASA                     |
| 9.30  | The Use of Systems Analysis in Industrial Decision-Making   | R. Tomlinson, IIASA                  |
| 10.00 | Keynote Address   | P. Rautalahti, Finland               |
| 10.30 | Coffee Break  |                                      |
| 10.45 | Structural Problems in the Forestry/Forest Industry Sector. A world-wide survey by speakers from different countries. |                                      |
| 12.30 | Lunch   |                                      |
| 14.00 | Presentations from different countries continued  |                                      |
| 15.45 | Tea Break   |                                      |
| 16.00 | IIASA's Forest Industry Project Discussion  | P. Uronen and<br>R. Tomlinson, IIASA |
| 18.00 | Heuriger  |                                      |

Wednesday, January 9

Chairman: P. Wrist, USA

- |       |   |                     |
|-------|---|---------------------|
| 9.00  | An Overview on the Use of Systems Analysis in the Forest Sector   | P. Uronen, IIASA    |
| 9.30  | Opening Remarks for the Discussion                                | A. Andersson, IIASA |
| 10.00 | Discussion about the Use of Systems Analysis in the Forest Sector |                     |
| 10.30 | Coffee Break  |                     |



Wednesday, January 9 (continued)

- 10.45 Discussion on suitable topics and arrangements  
for a collaborative study
- 12.15 Conclusions and Recommendations for the Forest  
Industry Project R. Tomlinson, IIASA  
and L. Reed, Canada
- 12.30 Lunch

APPLICATION PART

Session: "Modeling of World Market and Global Aspects"

Chairman: A. Wierzbicki, IIASA

- 14.00 -- "On the Possibility of Creating Consistent  
Forecasts of World Trade in Forestry  
Products" A. Andersson, IIASA
- "World Economical Modeling" D. Nyhus, IIASA
- 15.45 Tea Break
- 16.00- -- "Comparative Economics of Plantation  
17.30 Forestry" R. Sedjo, USA
- "Integrated Utilization of Tropical  
Forests" D. Noack, FRG

Thursday, January 10

Session: "National and Regional Modeling of the Forest Sector"

Chairman: M. Atbegov, IIASA

- 9.00 -- "Forest Sector Model" M. Kallio, IIASA and  
R. Seppälä, Finland
- "The Forest Industry and Regional and  
Industrial Development Policies" B. Johansson, Sweden
- 10.30 Coffee Break
- 10.45 -- "The Forest Industry Model of Canada" K. Jegr, Canada
- "Modeling of the Swedish Forest Sector" S. Nilsson, Sweden

12.30 Lunch

Session: "Forest Management"

Chairman: L. Lönnstedt, Sweden

- 14.00 -- "Applications of Systems Analysis in US  
Forest Service Assessments and Planning" C. Row, USA
- "A Multiple Criterion Two-Stage Model for  
National Forest Management Planning" P. Dress, USA
- "Spatial Integrity in Forest Planning Models" D. Dykstra, USA
- 15.45 Tea Break

Thursday, January 10 (continued)

- |       |  |                     |
|-------|--|---------------------|
| 16.00 | -- "Modeling Timber Supply from Private Nonindustrial Forests"   | C. Binkley, USA     |
|       | -- "Development of a Mathematical-Economic Computer Model for Updating the Hungarian Forest Management System" | I. Gondocs, Hungary |

Friday, January 11

Session: "Management Systems in the Forest Industry"

Chairman: R. Tomlinson, IIASA

- |       |   |                      |
|-------|---|----------------------|
| 9.00  | -- "Management Systems in Forest Industry: An Overview"                   | P. Uronen, IIASA     |
|       | -- "Methods for Production Planning in an Integrated Pulp and Paper Mill" | K. Leiviskä, Finland |
| 10.30 | Coffee Break  |                      |
| 10.45 | -- "A Production Planning System for Pulp and Paper Mills"                | L. Einarson, Sweden  |
| 12.00 | Concluding Remarks and Summary of the Workshop                            | L. Reed, Canada      |
| 12.30 | Closure.  |                      |

THE FOREST INDUSTRY--ISSUES FOR THE EIGHTIES  
An IIASA Industry Project

Discussion Papers of the Planning  
Task Force Meeting  
July 10-12, 1979

GENERAL

(1) The International Institute for Applied Systems Analysis is a non-governmental research institute based at Schloss Laxenburg, Vienna, studying common problems of the developed world. It is funded by seventeen member countries through their Academies of Science or a nominated scientific body of similar standing. Most of the work is undertaken by scholars from the member countries seconded for one or two years from their home institutions, which may be industry, independent research organisations, or universities. The problems tackled are organised into two Programs: Energy, and Food and Agriculture; and four research Areas: Resources and Environment, Human Settlements and Services, Management and Technology, and System and Decision Sciences. There is also a General Research Area which includes the study of regional development problems. The work is 'applied' in the sense that it is directed towards real problems, and attempts to provide improved information and methodology for the use of those who advise managers and decision-makers, at both organisational and national levels, in the member countries. One example of this is the work that IIASA has done earlier on the budworm problem.

(2) For the purposes of research, it has been necessary to identify IIASA's research program in terms of distinct tasks. For example, the Management and Technology Area has four main tasks which are currently being researched, namely: problems of industrial innovation, questions of scale, the impact of small-scale computer systems on management and organisation, and management problems associated with high risk technology. In practice, however, the problems which face management do not divide into such simple categories. Problems are interrelated and are becoming ever more complex. The rate of change in our society is such that

new problems are continually arising and if we are to meet them adequately, we need to prepare the tools and analysis well in advance. Systems analysis is increasingly becoming a major tool for use in such situations.

(3) If, however, systems analysis is to be effectively used in an industry, the tools need to be developed in cooperation with management in the industry. The problems we are considering cannot be removed from the real-life contact and treated clinically as in a laboratory. Since it is not the function of IIASA to act as direct consultants to industry in any one country we can only effectively develop an improved methodology in conjunction with analysts and policy advisers in those organisations:

(4) From what has been said, if IIASA is to improve the methodology available for the assistance of decision-makers in industry, it is necessary for them to engage on "whole industry" studies. Equally, such studies are necessary if industry, in the various member countries, are to get full value from IIASA's research. Because of this, and the international nature of IIASA's work, we have been led to consider the possibility of international collaborative studies in selected industries which are facing major problems of change in many countries over the next ten to twenty years.

(5) The potential advantages to the industry chosen of such a study in obtaining better information on world issues, in sharing experience and techniques, in engaging in common research and in drawing on the wide knowledge of systems analysis which can be obtained through the Institute seem considerable. We do not pretend that we will solve problems for individual industries, but we do believe that we can help to provide tools that will help management to explore the possible consequences of the range of decisions available to them.

(6) The first industry chosen for study in this way is the coal industry and the work has already begun. Following discussions in many countries, the forestry/forest products industry has been identified as a second industry where such an approach is of potential value.

(7) We see this as essentially a collaborative research effort in which the majority of the research will be undertaken on a national basis. This is where the expertise already lies and the problems to be tackled are those to which many of these teams are already planning to devote attention. The role of IIASA will be as follows:

- (i) to provide a systems framework for the whole study, whereby separate parts can be analysed and inter-related;
- (ii) to provide a convenient vehicle for information exchange;

- (iii) to advise and help develop appropriate methodologies\*;
- (iv) coordinate the work and ensure that, so far as is possible, the individual pieces of research are relevant to all participants; and
- (v) make results of the work available to participants through reports, conferences, etc.

(8) The initial step will be to hold a workshop at IIASA on October 2-5, 1979 at which management will be invited to comment on the relative importance of the various problems that will have been suggested in discussion documents and to identify topics under so listed. They will also be asked to indicate their degree of support for working on individual topics in terms of research effort that they would be willing to provide in their countries or for support of research at IIASA or elsewhere. The second part of the workshop will be devoted to an information exchange between analysts to explore appropriate methodologies for these various problems.

(9) Two of the countries concerned have already set up analytical teams to study the questions set out in these notes and others are known to be considering doing so. It is important that the work should be done in, and through, such analytic teams. In order to ensure that the work remains focussed on the problems as seen by management in the industry, it would also be necessary to establish a 'reference group' of senior managers to advise on developments and, in effect to commission the work. A reference group for IIASA work with representatives from all NMO's actively involved in the project would also be established. Figure 2 describes the proposed organisation of the project.

(10) For the purposes of easier discussion, the problems will be divided into three groupings: resource management, structuring and planning, and production including the questions of energy and pollution. Figure 1 indicates how the whole industry study might be developed. A short discussion paper has been prepared on each of the subject areas and this will be the basis of the discussion at the workshop.

(11) A relatively small amount of funding for this project is available from internal IIASA resources. In view of the direct value of the work to the industries concerned it is hoped that it would be self-supporting and that the necessary resources at IIASA could be provided through industry secondments or from direct financial support of IIASA staff.

---

\* IIASA is already undertaking much work which is relevant in methodology or direct contact, to the studies envisaged here. It is studying problems of world demand and supply in energy and agriculture; it is looking at questions of the environment, innovation and technological change, problems of scale, impact of mini-micro computers, etc. These teams would be available for comment and advice, and could in some instances, engage on case studies with the forest industries.

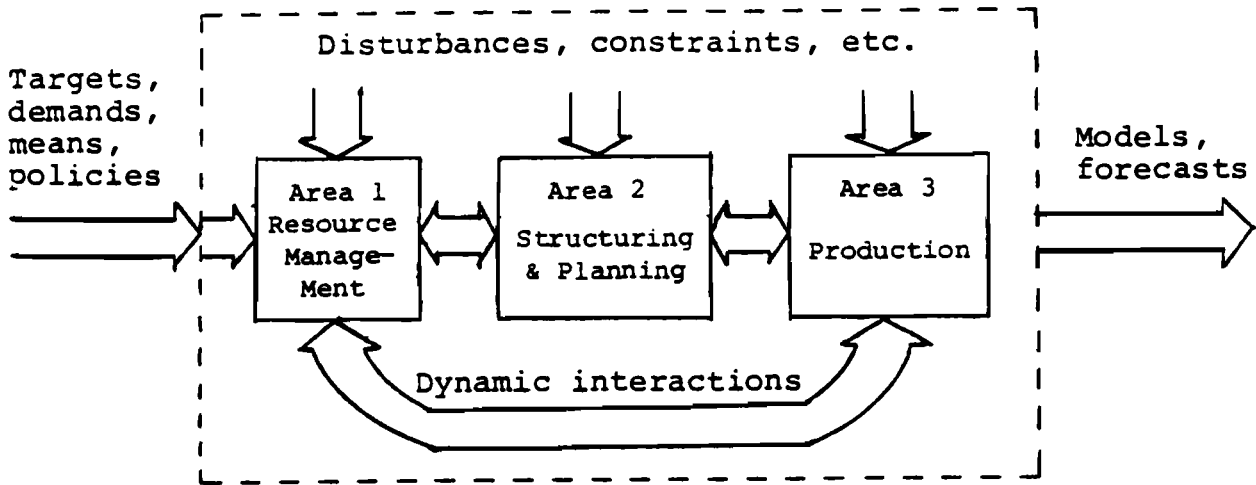

Figure 1: The International Project at IIASA, "The Whole Industry Study.

(12) To conclude, the purpose of this work is to provide management in the forestry/forest products industry with better information and better tools of analysis that can be used by an individual nation or company in understanding its own problems and in developing their own strategy. To the best of our knowledge, it does not duplicate work being undertaken anywhere else and should provide an existing breakthrough in mutually advantageous cooperation.

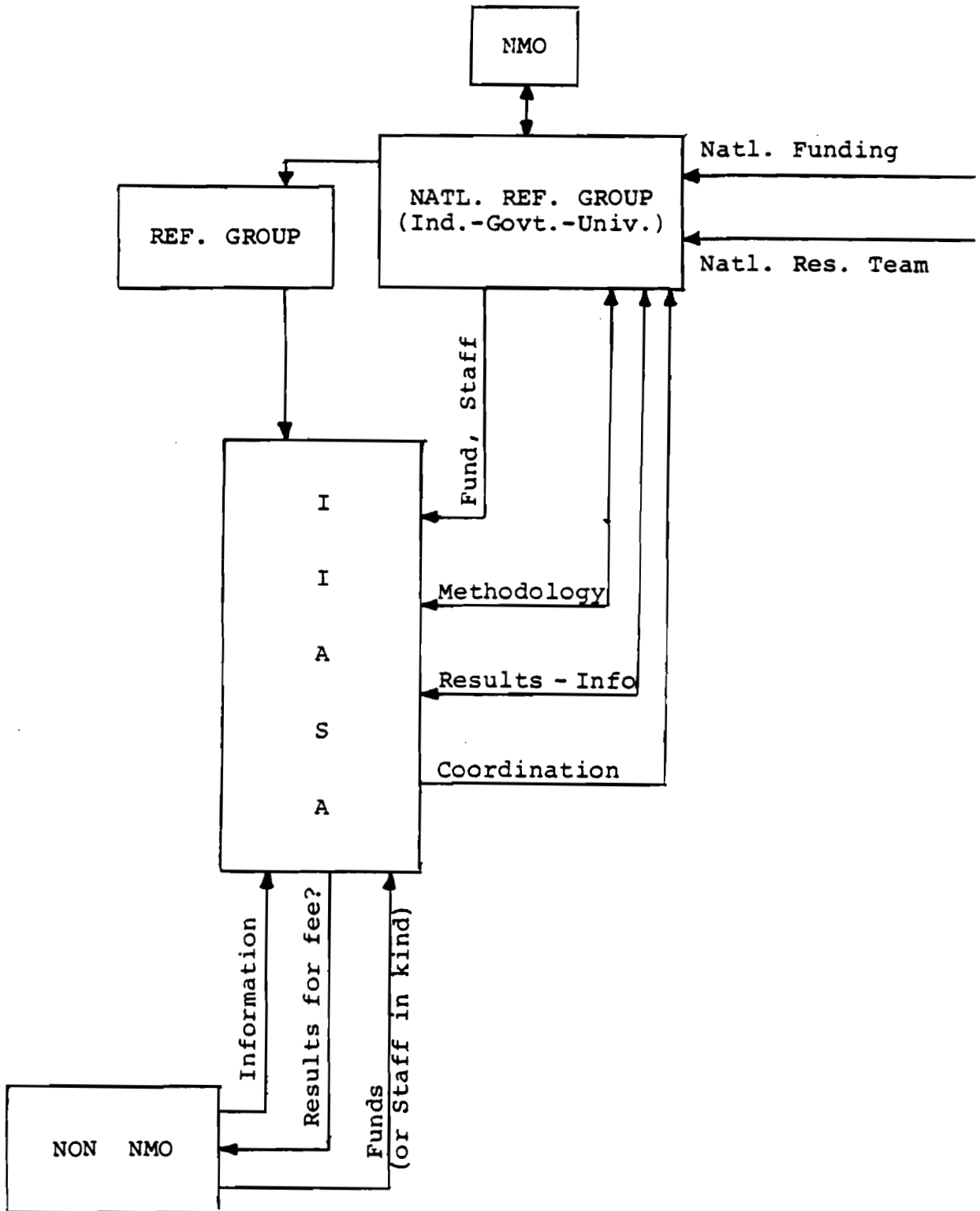
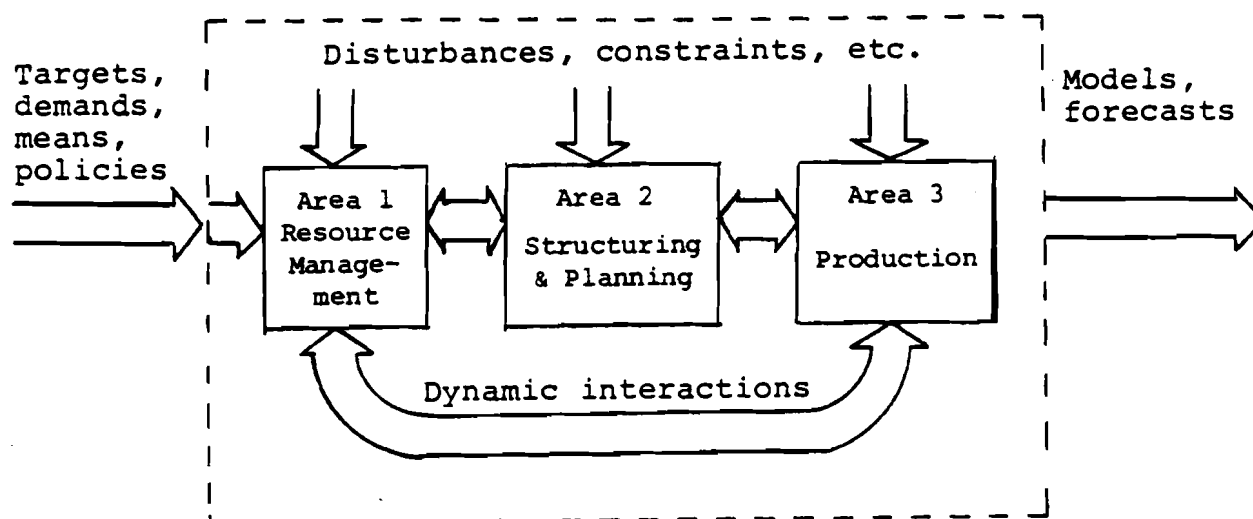

Figure 2: Possible Organisation of Forestry Study.

It is proposed that we should consider the overall topic under three subject areas as indicated in the following diagram. The following papers discuss each of the areas in turn.



#### AREA 1-- RESOURCE MANAGEMENT

For the purposes of this discussion, Area 1--Resource Management includes the activities associated with growing, harvesting and transporting fibre to the processing site. Although this is a complex Area, it is possible to demonstrate the advantages of a systems approach to planning by considering four characteristic issues of the Area. These are:

- (1) The interaction of fibre supply, fibre price, and product mix.
- (2) The internal competition (within total forestry) for the available forest productivity, including such trade-offs as between pulpwood, sawlogs and energy uses, or between consumptive or non-consumptive uses.
- (3) The flow of biomass from a forest unit in terms of quantity and quality, including how this is influenced by over- and under-harvesting.
- (4) The social effects of the mechanisation of harvesting.

These issues each contain interrelations and, while they may appear independent of one another, inspection will reveal a series of interactions. A systems approach provides a systematic scheme for evaluating the influence of these interactions. For example, a simple system structure in which the flow of actual material is shown as solid lines and the flow of information involved in



decisions as dashed lines, is given in Figure 3. Such a structure provides for explicit recognition of interactions both within the area and between this and the other two areas. In the context of this structure the interdependencies of the four issues become more manageable.

The fibre market is driven by areas 2 and 3, but this market must be responsive to harvesting and delivery costs in both the short and long run. Furthermore, the fibre market should influence, and be influenced by, the fibre supply in the longer run.

In the short run, the internal competition for the products of the forest takes place in the fibre market, but the results of this competition have substantial longer-term effects on the availability of supply in terms of both land use and management of the resource.

Conventional analyses frequently ignore the fact that the action of the fibre market, through the medium of harvesting, has a profound influence in the structure of the forest resource and consequently on the nature of the long-term fibre supply.

Increased mechanisation of harvesting can result in a spiral effect, where decreased labour needs result in an accelerating pressure to mechanise, and further adverse effects on the labour market.

The proposed IIASA project will develop formal expressions of interrelationships, at appropriate levels of resolution, to permit systematic exploration of reasonably possible futures of forestry operations in the larger context of the whole industry. The purpose here is to formally link considerations of resource management policy to market considerations in such a manner that limitations in both directions can be seen.

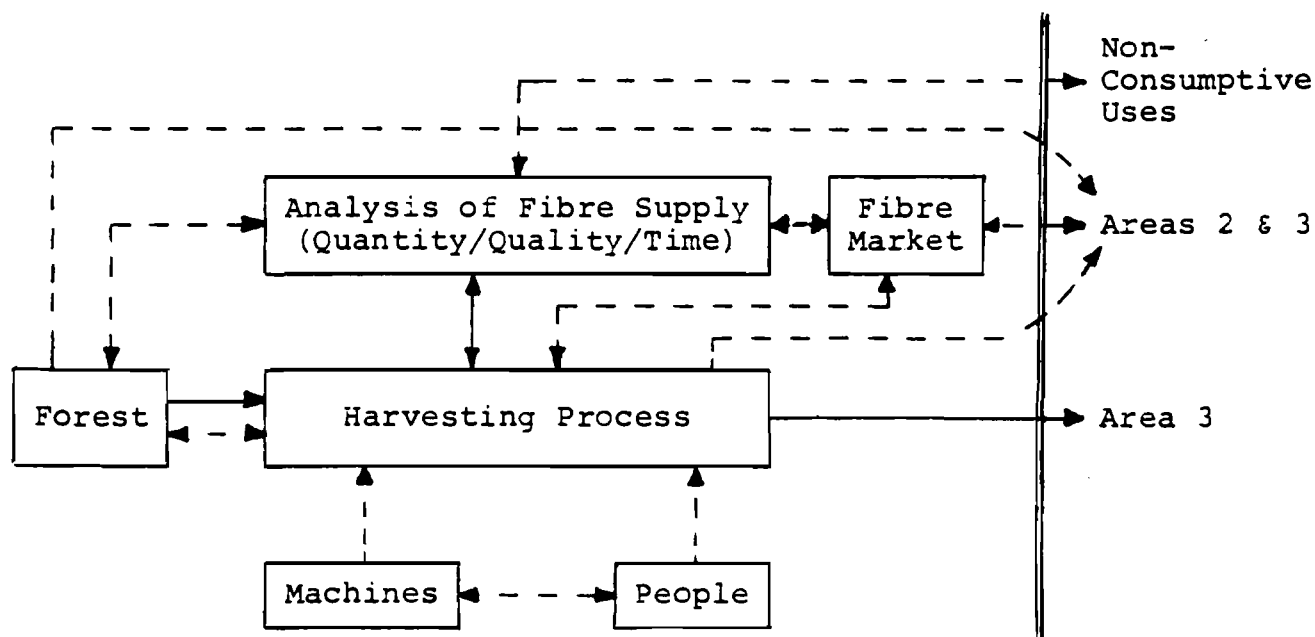

Figure 3: Interactions of the Areas.

## AREA 2--STRUCTURE AND PLANNING.

This area is concerned with factors lying outside the individual forest or the forest industry unit. It is concerned with the economic and institutional environment of the firms of this sector.

Traditionally, structural and macro economic development has been treated within a forecasting framework. This means that decision-makers within industry have tried to make projections, forecasts and scenario studies of its economic environment in order to create a good basis for their own decision-making. However, interactions between institutional and economic environmental factors and industrial decisions have increased in importance and it is now necessary to integrate the analysis of firm decisions and general economic and institutional development in some comprehensive approach. It is one of the major ambitions of this project to provide such a new approach to decision-making for forestry and the forest industry. Below we will give some pertinent examples of problems which have to be observed in such a systems analytic and comprehensive approach to this problem.

### Forecasting of the World Market Development Under Different Protectionist Policies.

Forecasts of the development of the world market in quantitative terms are available to the forest industry from FAO and different consulting agencies. These forecasts are normally rather crude in terms of disaggregation in different products and different geographical zones of the world market. They are crude in the sense that they do not take into account the interactions between different commodity types in resource allocation. It is thus often the case that forecasts for different products within the forestry sector, and for products outside the forest industry, are not tested against each other for consistency. More or less sophisticated trend projects are thus presented without being added together or analysed as a whole. This means that the industrial planners have to make their own independent projections of the development of relative prices of the commodities to be produced and used as inputs.

New techniques for simultaneous forecasting of disaggregated quantitative development, development of prices and development of demand as influenced by institutional changes are therefore of great need for a better planning of capacity expansion for the industry.

It should be an ambition to develop a new consistent methodology for forecasting of international demand and supply in situations of substantial changes in trade policies.

## Labour Market Policies and Regional Planning

The organisational structure of the labour market is of importance for the economics of the forest industry.

Persistent imbalances on the labour markets of regions with a dominance of forest industry due to nationally determined wage and tax policies indicate that the development of these regions should be analysed from a broad regional analytic point of view.

## Allocation of Capital and Other Resources Between Different Industries

The development of forest industries is frequently determined by a national development plan, a macro-economic program or general allocation policies. For the forest industry these national allocation guidelines are most important in the allocation of land and material capital. It is for these reasons necessary to develop a study of the forest industry within a national economic allocation framework in which the development of the forest industry can be traded off against development of other sectors of production.

## Long Term Change in Economic Structure and Research and Development Policies

The high capital intensity of the forest industry and the importance of economies of scale in this sector normally give rise to uneven development of the industry, especially at the regional level. It is therefore rather common that large production units have to be closed down or started up during very short time spans with considerable social consequences at the regional and plant level.

Many different groups besides industry, i.e., labour unions, regional policy-makers, trade policy-makers, etc., often have different and conflicting objectives in this respect. Methodological development should take this multiobjective nature of the long term structural policy problem into consideration.

For these, and other reasons, it seems to be necessary to develop some methods for analysing possible economic structural changes and R&D within an integrated, industry-wide framework.

## Energy Supply and Demand

The forest industry has a great importance in the context of energy supply and demand.

A study of energy in the forest industry from the points of view of consumption and controller of land suitable for biomass production is suitable at IIASA, which has a long tradition in studies of energy and society.

## Pollution and the Natural Environment

The forest industry sector is a large user of natural resources in the production processes. With the growing interest in environmental conditions the sector is now under severe pressure from different policy groups to engage in new, resource conserving production techniques. The environmental considerations are characteristically long term in nature and new methodologies for strategic planning of environmental and R&D policies for the forest industries must be developed.

## Living Conditions in Forestry Regions

The problem of creating modern social conditions in forestry regions is an important issue. Partly as a result of social conditions forestry regions are facing antimigration and a future of an insufficiency of labour supply.

## AREA 3--PRODUCTION

This Area deals with the problems involved with the short and long term operation and planning of the existing production capacity on corporate, regional and national levels. The problems here are highly interconnected with the problems in other areas. Figure 4 clarifies the interconnections, inputs and outputs of this area.

Effective use of recent developments in computer and information technology and modelling techniques is expected to give positive results in this area. It would be expected that models could be developed to enable one to study problems such as:

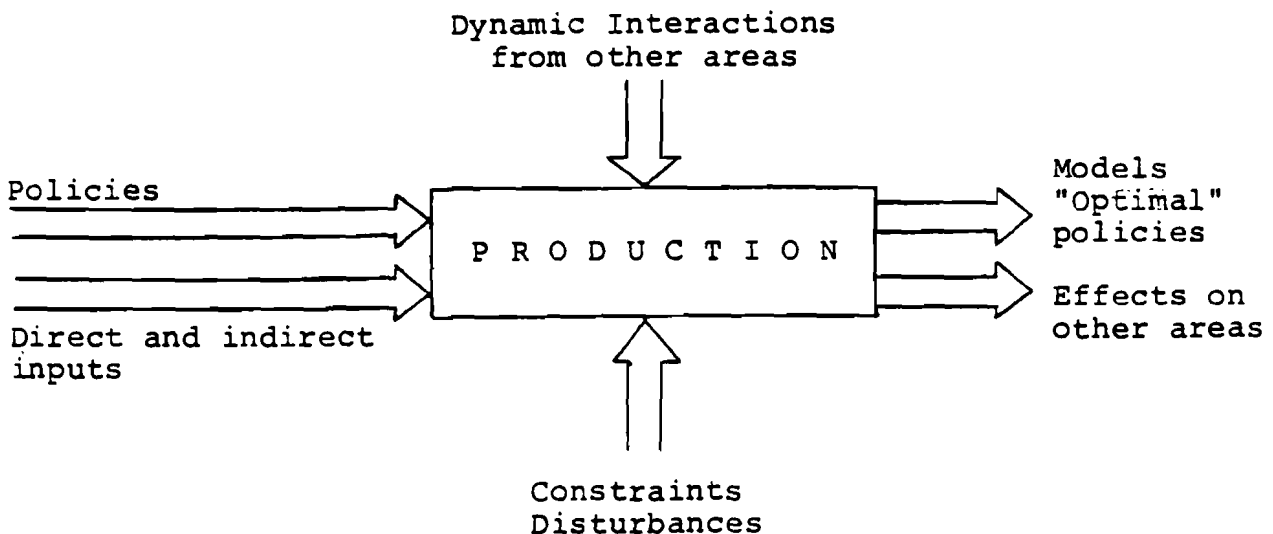

Figure 4: Clarification of the Interconnections, Inputs and Outputs of Production.

- Coordinated usage of forest resources;
- Coordinated operation of different mills (per production line, mill, corporate);
- Coordination of different production units (along a production line);
- Using forecasts and adjusting the operation accordingly;
- Production planning short-term and long-term (mill, corporate);
- Optimal operation of the mill (hierarchical control systems);
- Effects of changing technology (new processes, closed mill concept, energy, environmental constraints, etc.);
- Effects of changing computer and information technology (operation, demand);
- Effective use of system analytical tools and computer technology in management of forest industry enterprises and mills (hierarchical structure of information and Control Systems);
- Concept of very highly (or fully) automated pulp and paper mills;
- New energy concepts and low pollution mills.

The target of this project is to develop tools and general methodology for helping management in solving the above problems. Of course each mill or corporation will use their own data and modify the models for their own use in each actual case.

The models could be applied to a single mill or any number of mills and thus could help in the internal coordination of a company. Good forecasts, databanks and information and planning systems are essential and needed here. With respect to time scale, the problems range from time constraints in the order of magnitude of a few seconds at the production control level, to several years at the long-term planning level.

The models to be built and used will have different input data sets at different levels. For example, the hierarchical information and production control system in a mill mainly uses the measured data of the mill as inputs. The outputs of the system will be direct control actions and instructions to the personnel. As another example, the data needed for coordination and planning of the production will be different forecasts (demands, energy, labour, supply, etc.) and plant data (capacities, availabilities, etc.).

The third kind of problems in this area are the effects of changing technology, effects of different environmental issues, changing markets (competitive technology), different financing policies, etc. Earlier IIASA work in the SDS area might be utilized in these studies.

THE FOREST INDUSTRY--  
ISSUES FOR THE EIGHTIES

GENERAL

1. The purpose of this note is to provide background material to the proposals set out in the discussion papers prepared by the Planning Task Force meeting held in July 1979, and in particular to explore in more detail the kind of assistance that IIASA might be able to provide immediately--on the basis of work undertaken--and, more importantly, the kind of role that it could fulfill when the coordinated research project gets under way.
2. The omission of this material in the discussion notes was deliberate--for two reasons. In the first place, effective applied systems analysis in decision-making can only be undertaken when the problems are stated by the decision-makers themselves. The analysts may speculate and prompt, but they can only guess at the realities with which the managers deal. As they interact more closely so their intuition and understanding improves, but the work must be problem led. It was the intention of the discussion papers to suggest the kind of problems that management faces, whose solution can be aided (if not solved) by systems analysis. We felt that the choice of problem should come from decision-makers.

3. The reason for not giving details of existing work at IIASA is precisely because, as the problems have not yet been posed by the industry, all that IIASA has at present to offer are some models (which are new and powerful) and some major conceptual ideas, related for example to problems of innovation and computer usage. The models would be available to the industry, and we would welcome the opportunity to apply them in further real life situations where the results would be of value. But that must not be the main emphasis in the study. The main body of expertise in systems analysis related to the forest industry must lie in the forest industry itself--but because of our international position and our ability to draw on the leading experts in the field who have applied their knowledge in many fields, we believe that we can play a substantial role in helping the industry to concentrate its research efforts, draw more effectively on world wide knowledge, develop new methodology, and improve the effectiveness of implementation. It is a key role, but essentially a catalytic one.
  
4. In line with these ideas we have proposed that the inaugural workshop should be built around a discussion, led by the industry, of the major problem areas where systems analysis can be applied to help tackle the Issues for the Eighties. The analysts ideas of how to do this can then be considered, and a joint research program prepared. Before we discuss the possible form that this might take we should first consider work that is currently going on at IIASA that is relevant to the issues concerned.

#### RELEVANT WORK BEING CURRENTLY UNDERTAKEN AT IIASA

##### 1. World Trade Modeling.

An input-output forecasting system is under construction within the INFORUM-IIASA project. Currently, economic forecasting models for example for the following countries are in preparation: Austria, Canada, the Federal Republic of Germany, Finland, France, Hungary, Japan, Norway, Sweden, the United Kingdom and the United States of America. Work is now concentrated on linking these models into a world trade projection system.

It is often the case that trade forecasts for different products within an economic sector, and for products outside this sector are not tested against each other for consistency. However, the world trade system can be used to prepare consistent forecasts for imports and exports by commodity and by country. Besides alternative projects of the volume of exports and imports in physical units, also price projects may be obtained based on different assumptions about the development of prices of raw materials.

## 2. National Forestry Economics.

A simulation study of the Finnish forest sector was recently completed at the Finnish Forest Research Institute (FFRI). The purpose of this study was to investigate possible developments of the national forest sector taking into account raw wood availability as well as labor, production and financial resources. A subsequent phase of this study was started at IIASA in 1978 in connection with its dynamic linear programming task and in cooperation with FFRI. Instead of simulation, optimization techniques are used as they better suit for studying the inherent multiple-criteria group decision problem.

The intention of this case study is to give the policy makers some insight for the possible outcomes of different policies in their task concerning long-range development of the Finnish forest sector. A further question, of special methodological interest to IIASA is to study policy formation when the policy makers represent interest groups with varying objectives and actions for control. In this context such groups may be the forest industry, labor unions, forest owners, financial agencies and local and national governments. The intention is to develop an approach which is a theoretically valid procedure and yet can be applied to practice when solving such group decision problems. Naturally, this study being carried out at IIASA would provide a framework for producing similar studies for other nations.

The approach described above may easily be extended to regional economic studies of the forest sector (provided that the data is available at the regional level).

## 3. Regional Studies.

The problem of land allocation between agriculture, forestry and other space-intensive activities has a high priority as a topic of research at IIASA. The best balance for example between forestry and agriculture in land use does not always result from the free market forces in a number of countries. The prices of agricultural commodities are, for instance, often kept at a high level with the aid of custom duties and import quotas and thus the prices of agricultural products often result in a too high value of land for agriculture as compared to forestry. It is consequently useful to develop regional land use models with a simultaneous consideration of different agricultural and forestry uses.

Such models have been developed at IIASA in connection with case studies of regional development. One of these models has been designed to cope with transportation, other logistical problems, and environmental costs under conditions of economies of scale. It is possible to adapt these models to a study of efficient use of land with an explicit consideration of multiple objectives.



Models of sectoral and regional allocation of labor, investments, and renewable and non-renewable natural resources have been developed at IIASA. These models are currently being tested in a number of countries, including Sweden, Bulgaria and Poland. A full consideration of the regional problems of the forest industries would not require major new basic research but rather some further analysis and adaptation of these models.

#### 4. Problems of Technological Change.

The forest industry is facing many changes and problems which will directly or indirectly affect the technological development. The task of exploring the direction of changes and identifying the impacts, stimulants and barriers of this technological change in the forest industry would be important. It is not simply a question of putting more money into R&D but also of identifying the most important fields of technological innovation and technological options which are needed in order to cope with coming changes and constraints. Also the medium and long-term interactions between different technologies and between technology and its environment are not well understood and studied. The problems of technological change is an ongoing task at IIASA. In this project general conceptual ideas of technological innovation, problems of diffusion of innovation with industries and different innovation policies are studied. Several case studies of various industries will also be done and the forest industry could be one of these.

#### 5. Effects of Small Scale Computers.

The general objective of this ongoing IIASA task is to study the changes in work and organization that will follow from rapid development and changes in small scale computer technology. Key questions then are, for example, the proper design of information systems and the effective man/computer interface.

Computer technology and management information systems started their diffusion into the forest industry about twenty years ago. Today there are about 2,500 computer systems in this industry, most of these are controlling technological processes (paper machines, digesters, bleach plants, etc.). In addition to this, more and more interest towards production planning and management information systems in this industry has arisen and some systems are already in operation. The development in computer hardware and software will open new possibilities and rapid development of these systems. The findings and results of the ongoing IIASA task on the effects of small scale computers will be useful and applicable to the forest industry.

#### POSSIBLE WORK NOT YET BEING UNDERTAKEN AT IIASA

The work that IIASA could contribute to a combined study of the kind we are discussing could fall into one of three categories, deriving from different aspects of the Institute's work.

- (a) Because of its international character, the Institute is particularly suited to undertaking studies of a global character, requiring information and collaboration from many countries.
- (b) As an interdisciplinary institute of scientific excellence, we are able to provide technical assistance or undertake basic research in most aspects of modelling--particularly relating to optimization, simulation, economies, control theory--and in many fields of application energy, agriculture, environment, etc., etc.
- (c) As an institute of applied systems analysis we have on our staff experts with long experience in the effective use of systems analysis by managers at all levels. The study and development of management information systems and decision support systems in the forest industry are examples of research which could be undertaken in IIASA.

#### POSSIBLE RESEARCH PLAN

1. International collaborative project; main part of research will be done in member countries by national teams on topics of national interest, organization and IIASA's role as explained in the Discussion Papers FN/1.
2. IIASA's main efforts could include:
  - coordination and dissemination of results and information;
  - constructing a world trade model and long term forecasts for forest products;
  - studies in innovation in management information systems and effects of small scale computer technology in the forest industry;
  - assisting in use and further development of individual models developed in one country, making them more generally available for exchange.
3. In addition to the scientists doing work on those topics mentioned above, IIASA staff currently includes a specialist in automation and information systems in the forest industry working full time in this project. If the world trade model of forest products were to be

built, 2-3 additional staff members would be needed; the overall coordination of the project and other topics listed would mean that a total of about six people were necessary. These new staff members should mostly be drawn from the industry itself. The best way to solve this recruitment problem would be by secondment. Recruitment would, of course, be a critical element in determining the appropriate time scale for the project.

4. The estimated total length of such an international project is approximately three years.
5. A detailed research plan and time schedule will be prepared following discussion at the inaugural workshop on January 8-11, 1980 in Laxenburg, Austria.

#### BENEFITS TO THE INDUSTRY AND IIASA.

The basic idea and responsibility of IIASA is the further development and application of systems analysis. The emphasis is on the word application and for real application work IIASA needs the cooperation and support from industry and other decision-makers. We see this study as an important element in achieving this general objective. But any particular collaborative study needs more direct advantages than this to the parties concerned, and in particular to the industry itself. The most obvious possible benefits to the industry from this project are:

- Easy exchange of systems analytical and other interdisciplinary information at international level as related to the forest industry. It is well-known that the exchange of information concerning technology and other knowledge closely connected to the special questions of industry is well-established but this is not valid in systems analytical and other interdisciplinary areas.
- Access to international expertise in applications of systems analysis and related areas. IIASA staff includes experts from a wide range of applications and knowledge and in addition IIASA has good contacts with most institutes and scientists working in this area.
- Maximum return from research expenditure; i.e., possibility to get, for example, long-term global forecasts of the world trade of forest products and methodology suitable for applications in national and local problems of the forest sector with a moderate expenditure.

- More efficient use of systems analysis in corporate, regional and even national levels.

Besides those general targets mentioned above this industry project would give IIASA:

- a specific incentive for methodological development;
- better understanding of real decision-making process in individual organizations;
- a test-bed for IIASA products; and
- necessary contacts with real life.

We feel that this kind of project is an effective way to use the unique international character and all experiences and expertise of IIASA.