



Analysis of Model and Parameter Uncertainty in Simple Phytoplankton Models for Lake Balaton

Straten, G. van

IIASA Working Paper

WP-80-139

September 1980



Straten, G. van (1980) Analysis of Model and Parameter Uncertainty in Simple Phytoplankton Models for Lake Balaton. IIASA Working Paper. WP-80-139 Copyright © 1980 by the author(s). <http://pure.iiasa.ac.at/1330/>

Working Papers on work of the International Institute for Applied Systems Analysis receive only limited review. Views or opinions expressed herein do not necessarily represent those of the Institute, its National Member Organizations, or other organizations supporting the work. All rights reserved. Permission to make digital or hard copies of all or part of this work for personal or classroom use is granted without fee provided that copies are not made or distributed for profit or commercial advantage. All copies must bear this notice and the full citation on the first page. For other purposes, to republish, to post on servers or to redistribute to lists, permission must be sought by contacting repository@iiasa.ac.at

WORKING PAPER

ANALYSIS OF MODEL AND PARAMETER
UNCERTAINTY IN SIMPLE PHYTOPLANKTON
MODELS FOR LAKE BALATON

Gerrit van Straten

September 1980
WP-80-139

NOT FOR QUOTATION
WITHOUT PERMISSION
OF THE AUTHOR

ANALYSIS OF MODEL AND PARAMETER
UNCERTAINTY IN SIMPLE PHYTOPLANKTON
MODELS FOR LAKE BALATON

Gerrit van Straten

September 1980
WP-80-139

Working Papers are interim reports on work of the International Institute for Applied Systems Analysis and have received only limited review. Views or opinions expressed herein do not necessarily represent those of the Institute or of its National Member Organizations.

INTERNATIONAL INSTITUTE FOR APPLIED SYSTEMS ANALYSIS
A-2361 Laxenburg, Austria

THE AUTHOR

G. VAN STRATEN is with the Department of Chemical Technology, Twente University of Technology, Enschede, The Netherlands (formerly, a research scholar at IIASA from April, 1978-December, 1979).

PREFACE

One of the principal themes of the Task on Environmental Quality Control and Management in IIASA's Resources and Environment Area is a case study of eutrophication management for Lake Balaton, Hungary. The case study is a collaborative project involving a number of scientists from several Hungarian institutions and IIASA. This paper, originally prepared for the Second ISEM Conference on the State-of-the-Art in Ecological Modelling (Liege, Belgium, April, 1980), is a further contribution to the Lake Balaton case study. The primary objective of the work reported is an examination of the major modes of phosphorus exchange between the water and sediments in the lake. The model used for this examination is one of three models currently being developed for the analysis of data characterizing recent variations of water quality within the lake. Results are reported for a comparison of the performance of the model with observations recorded for 1977. Corresponding results using one of the other two models are presented in an earlier working paper (WP-80-88).

A second principal theme of the Task on Environmental Quality Control and Management concerns methodological problems of modeling poorly-defined environmental systems, in which accounting for the effects of uncertainty is of key significance. This paper, in contributing also to this second theme, illustrates well the important interplay between case study problems and methodological developments.

ABSTRACT

The principal aim of the investigation is to analyze the major modes of phosphorus exchange between water and sediment from uncertain data of phosphorus fractions in the water. Based on a priori knowledge two relatively simple models have been postulated. State variables are winter and summer algae phosphorus, detritus phosphorus and orthophosphate phosphorus. Most parameters of the model were estimated or inferred from data from independent measurements. Several sensitive parameters, most of them related to the sediment-water interaction processes remain unknown. In the first model coprecipitation of phosphorus with biogenic lime, sedimentation of detritus and release of orthophosphate from the sediment is accounted for. This model predicts a rise in orthophosphate after the spring and autumn blooms not observed in the data. In the second model a mechanism of adsorption/desorption of phosphate to the sediment or suspended particles is postulated, to account for the remarkable stability of orthophosphate over the year. A Monte Carlo simulation is run to find areas in the parameter space where the model produces results fully within specified boundaries drawn around the data to account for the data uncertainty. Data and forcings from 1977 are used for this purpose. Several parameter combinations were found, and the results were analyzed in terms of the model processes. It is concluded that an adsorption/desorption mechanism is likely to occur, but that various modifications of the postulated model would be desirable. Further analysis using 1976 data is needed. The results suggest that it is worthwhile to perform additional field experiments with lake water and sediments in order to confirm or reject the sorption hypothesis.

ANALYSIS OF MODEL AND PARAMETER
UNCERTAINTY IN SIMPLE PHYTOPLANKTON
MODELS FOR LAKE BALATON

Gerrit van Straten

Introduction

System identification and parameter estimation are necessary steps preceeding the application of any mathematical model designed for management and control. In a typical modelling procedure first a model is postulated, usually based on some a priori knowledge about the system under study; then, an attempt is made to estimate a unique set of parameters by matching model results with available data; and, finally the error sequence is examined in order to detect structural deficiencies of the model. Although this procedure is sound in principle, its application to the eutrophication problem of lakes is seriously hampered in the majority of practical cases for three major reasons: (i) large uncertainty in observation data, mostly because of sampling errors and identification errors; (ii) uncertainty in forcing functions and input data due to stochastic variability in combination with deficient recording; (iii) only very incomplete knowledge about biological, chemical and hydrophysical processes.

Several of these problems have been addressed in recent publications. The effect of observation errors on parameter reliability and prediction errors was discussed in Beck et al. (1979). Fedra et al. (1980) drew attention to the fact that very often no unique parameter set exists if the data and input variability is taken into account. Consequently, rather than a unique prediction, a probability density function must result. The non-uniqueness of the parameters was earlier pointed out by Spear and Hornberger (1978), in an attempt to separate the parameter space in a region giving rise to a pre-defined model behaviour, and a region not giving rise to the behaviour. The behaviour was defined in a wooly way from scarce field data. The purpose was to test various assumptions on the phosphorus cycle in the system under study. The present paper reports on similar work in a practical application to the eutrophication problem of lake Balaton, a shallow lake in Hungary.

In most shallow lakes the water-sediment interaction is believed to play a significant role in the eutrophication phenomena. At the same time very little is known about this relation by direct experimentation. The principle aim of this paper is to investigate the major modes of phosphorus transport to and from the sediment on the basis of available data for in-lake phosphorus fractions associated with considerable uncertainty. The approach is directed towards hypothesis testing, that is, to see whether or not certain assumptions must be rejected in the light of the data. For this purpose a couple of alternative simple models is formulated, using as much information about parameters, processes and forcings as possible. The remaining unknown parameters, typically associated with the water-sediment interaction, are considered as 'tuneable' parameters. These parameters can be varied by hand, but also in a Monte Carlo simulation procedure, to see whether parametersets exist for which the model shows a phosphorus behaviour that matches the observed behaviour. In this context behaviour is defined as a set of (simple) constraint conditions around the actual data, to allow for the data uncertainty. Thus, a model solution is said to show the behaviour if the concentration patterns fall within the boundaries specified in the behaviour definition.

Lake Balaton

Lake Balaton is a long-shaped lake of approximately 70 km length, 8 km width and with an average depth of 3.14 m. The major inflow is the Zala River, draining about 50% of the total watershed area (6000 km²; see Figure 1). There is only one outflow, at Siofok, at the other end of the lake. Most (bio)chemical constituents show a marked concentration gradient, with the highest concentrations near the Zala inflow in the Keszthely Bay (see below). Wind action is important, but not sufficient to cause a complete mixing over the length of the lake. Wind induced currents and waves are instrumental in the continuous resuspension of sediment particles.

Biological observations comprise biomass measurements and phytoplankton counts, as well as primary productivity measurements employing the ¹⁴C-technique (Herodek, 1977), but only at one location each year in a year-to-year rotation scheme. The concern about the development of the lake's eutrophic state stems from the observation that the primary production in the Siofok basin doubled in the period 1972-1977 (from 96-180 g C/m² yr), whereas in the Keszthely Bay already in 1973-1974 a yearly primary production of 830 g C/m² yr

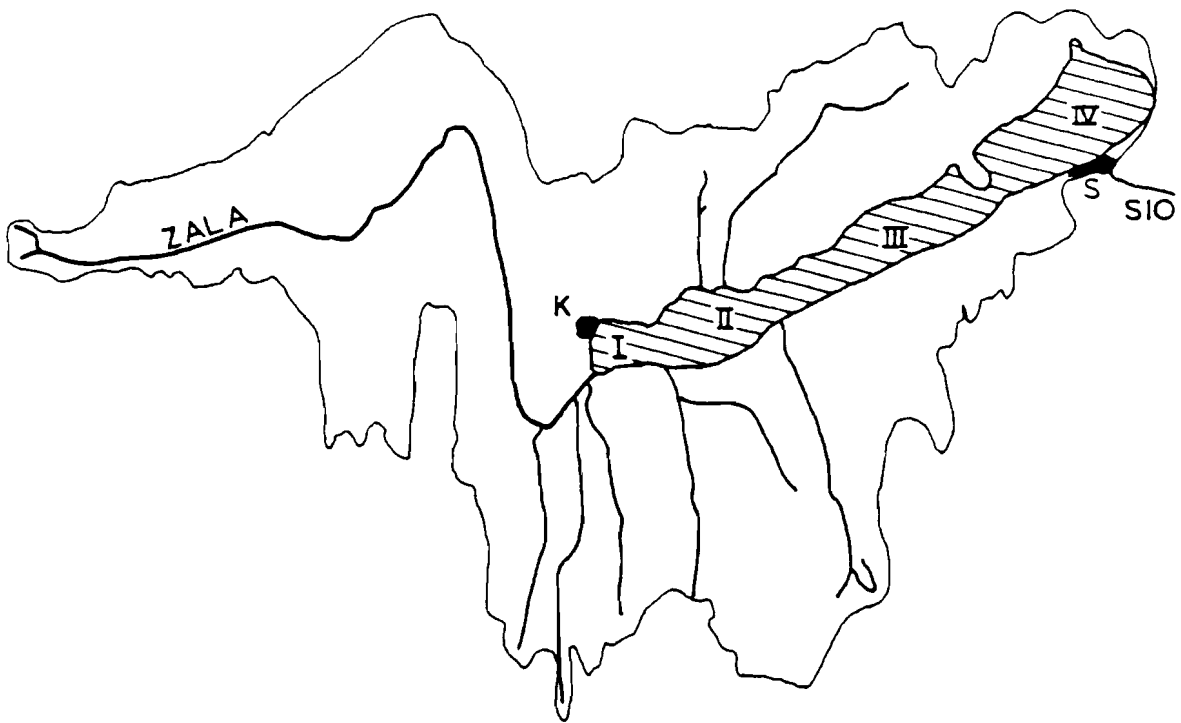

Figure 1. Lake Balaton and its watershed.

K = Keszthely, S = Siofok

was reached, a hypertrophic value.

Regular data are available on chlorophyll and various phosphorus fractions, measured roughly ten times a year on nine locations since at least 1975. Figure 2 summarizes the phosphorus fractions reported: total P, total dissolved P, ortho-P and particulate inorganic P are observed directly, the other fractions have been calculated (and are, consequently, less accurate). The data have been included in IIASA's Lake Balaton data bank (Van Straten et al, 1979). For the purpose of the analysis the lake has been segmented into four basins, and basin-averaged values were computed from the nine measurement locations according to their position. Geometric averages over the year 1977 are shown in Table I for the four basins. (The dynamic patterns are presented in Figure 9 as well.) The longitudinal gradient is immediately apparent from this table. Also remarkable is the high level of total dissolved phosphorus, indicating large dissolved organic and condensed polyphosphate concentrations, because ortho-phosphate is always very low. Of the particulate organic phosphorus roughly half is phytoplankton. Thus, the data show that detritus phosphorus is a substantial fraction of total

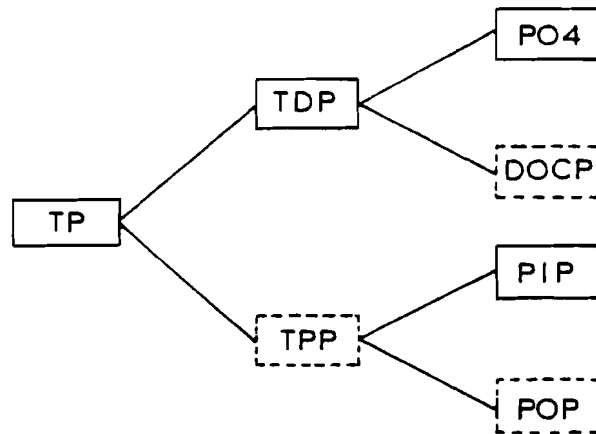

Figure 2. Reported phosphorus fractions for Lake Balaton.

Directly measured (solid lines): TP-Total P, TDP-Total Dissolved P, PO4-Orthophosphate, PIP-Particulate Inorganic P; calculated: TPP-Total Particulate P, DOCP-Dissolved Organic and Condensed P, POP-Particulate Organic P

phosphate in the lake. Roughly 10-15% of the total phosphorus is in the form of particulate inorganic P. This fraction is fairly constant throughout the year, except in stormy periods, when PIP can reach up to 40 mg P/m³. The ratio of PIP to total suspended solids ranges between 0.5 and 1.5 mg/g. Calcium carbonate is an important constituent of the suspended solids. During the year a considerable calcium precipitation occurs (ca. 75%, Entz, 1959), mostly as biogenic lime precipitation in the growing season. The pH is 8.3-8.7 throughout the year.

Modelling

Since the purpose of the modelling is to test assumptions on the major modes of phosphorus cycling, it was decided that the model(s) should be as simple as possible. This was considered a necessity also in view of the quantity and quality of the data. On the other hand due regard should be given to those aspects that were relatively well known for the lake, such as meteorological and hydrological data.

Table I. Geometric mean of 1977 phosphorus data, for the four basins and the lake as a whole (stormy days excluded), mg P/m³

		I	II	III	IV	Lake
Volume	10 ⁶ m ³	82	413	600	802	1897
Total P	mean	81.1	63.4	42.1	29.9	43.3
	<i>s.d.</i>	8.0	8.7	8.2	4.2	
Total Dissolved P	mean	25.2	18.8	14.1	13.1	15.2
	<i>s.d.</i>	8.1	6.1	4.3	3.9	
PO ₄ -P	mean	4.7	4.7	4.4	3.4	4.0
	<i>s.d.</i>	2.1	1.1	0.9	0.7	
Dissolved Organic P	mean	20.6	14.1	9.8	9.6	11.1
	<i>s.d.</i>	7.5	6.5	4.4	4.1	
Total Particulate P	mean	55.9	44.6	27.9	16.8	28.0
	<i>s.d.</i>	11.6	7.8	10.0	6.7	
Particulate Inorganic P	mean	10.3	8.3	6.7	4.4	6.2
	<i>s.d.</i>	5.0	2.4	2.4	1.8	
Particulate Organic P	mean	45.6	36.4	21.2	12.2	21.8
	<i>s.d.</i>	10.1	7.0	8.4	7.4	

The loading situation

The present phosphorus loading has been studied by Van Straten et al. (loc. cit.). Basically, the known elements in the loading are the total- and ortho-phosphorus load carried by the Zala River (obtained from weekly data), a tentative estimate of the total sewage load, and data on the total- and orthophosphate concentrations in precipitation. For the model also the contributions by the tributaries, as well as the distribution of the sewage load over the four segments had to be known. For this purpose the Zala particulate P-load was extrapolated based on watershed surface area and average slope for the tributary watersheds. The sewage loads were distributed according to population density and sewage connection ratio. Consequently, the loading to the various basins could be estimated from the Zala River data (dynamically) and from the total sewage load (constant, but twice the normal value during the tourist season), as shown in Figure 3. The sewage load is either direct to the lake or through the tributaries. Other sources of dissolved phosphorus are included in the total sewage load estimate and therefore not accounted for separately.

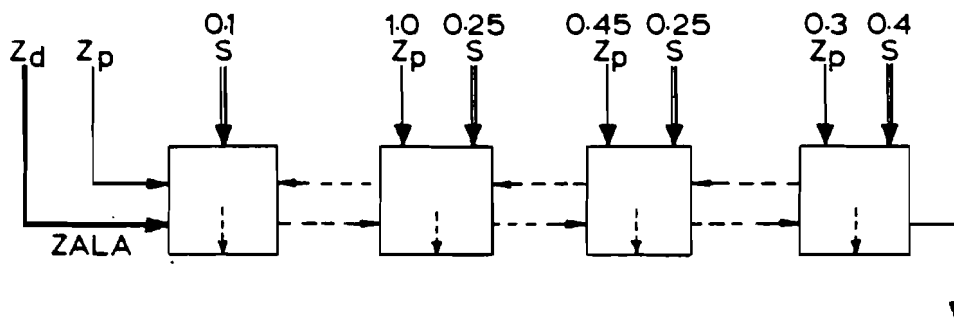

Figure 3. Phosphorus loading distribution.

S-sewage, *Z_p*-Zala Particulate P, *Z_d*-Zala Dissolved P

Hydrology and longitudinal mixing

Monthly data on precipitation, inflow, outflow and evaporation were available. These were used for the computation of basin-to-basin throughflow. In terms of the timescales relevant to ecological

modelling the effect of throughflow is insignificant (flow velocity less than 1 mm/s). However, significant currents do exist in the lake as a consequence of wind action, and consequently some longitudinal inter-basin exchange is to be expected. In the models, longitudinal mixing is approximated by the formulation of a circulation flow at each basin-intersection, on top of the hydrological flow, as exemplified in Figure 4. Thus, a dispersion effect is

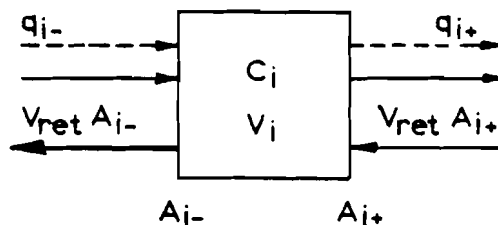

Figure 4. Exchange rate formulation.

C -concentration, V -volume, q -hydrological flow rate,
 V_{ret} -exchange velocity, A -cross sectional surface area

$$V_i \dot{C}_i = + (Q_{i-} + V_{ret} A_{i-}) C_{i-1} + V_{ret} A_{i+} * C_{i+1} \\ - (Q_{i+} + V_{ret} A_{i+}) C_i - V_{ret} A_{i-} C_i$$

introduced, which is governed by the artificial return velocity parameter V_{ret} . It should be emphasized that this parameter has no direct relation with the actual currents, although its value must certainly be less than the surface velocities (which are in the order of a few cm/s). Two and three-dimensional hydrodynamical models are under construction to study the transport phenomena dynamics, but no results have been obtained yet. In the present application, therefore, a constant longitudinal mixing throughout the year had to be assumed. On the other hand this is not unreasonable because the wind is fairly evenly distributed over the seasons. Experimentation with the model showed that V_{ret} had to be in the order of a few mm/s, because at higher values unrealistically low concentration gradients occurred. It also came out that the distribution of phosphorus and phytoplankton over the lake is rather sensitive to this parameter.

Algal dynamics

The lake is characterized by two algae blooms over the year (cf. Figure 9), although these are not every year as distinct as in 1977. Algal counts indicate that the spring bloom is mainly associated with diatoms, in recent years mostly *Synedra acus* and *Nitzschia acicularis*. The water temperatures are below 12 C in this period. Later in the season a mixed phytoplankton prevails, dominated by *Ceratium hirundinella*, and in recent years in the Keszthely and Szigliget basins also blue-green species (mainly *Aphanizomenon flos-aquae*) occurred. To account for the differences in environmental sensitivity over the year it was decided to introduce two groups of algae species in the model, denoted by the terms "winter-" and "summer-" algae, respectively. The differences between the groups lie mainly in the temperature sensitivity and the maximum growth rate. Both characteristics were derived from an analysis of the primary production data. From these data it was also clear that light inhibition occurred at the surface, and consequently the light limitation was described with the depth and day averaged Steele formula. The equations and parameters used are presented in Appendix I.

It should be noted that the maximum growth rate obtained from the primary production data analysis was extremely high as compared to literature data. In the model the values 2 and 6 day⁻¹ are used for "winter-" and "summer-" algae respectively. No explanation is known for these very high values. With such extreme growth rates there must be a very significant death process in the lake. Detailed zooplankton studies (P.-Zánkai and Ponyi, 1976) revealed a maximum filtering rate in summer of 1.4 ml/day per individual, while concentrations are at most 7 ind/l. Consequently, zooplankton could not be the major cause of the algal death process. Since nothing is known about the mortality it was assumed in the model that mortality is proportional to biomass. The rate coefficient was estimated as roughly 0.13 day⁻¹ at 20 C by matching the autumn decline of phytoplankton in model and reality. However, the temperature dependency, described by an exponential function, was retained as a "tunable" parameter. The value range chosen was slightly higher than usual to give some account for a temperature coupled zooplankton effect.

Phosphorus_cycling

There is general consensus about the major processes in the in-lake cycling of phosphorus. Algae excrete organic phosphorus in dissolved form, and mortality leads to particulate detritus material. Part of this is lost from the cycle through settling, whereas the other part is hydrolyzed, thus contributing to the dissolved organic P pool too. Finally, heterocyclic bacteria mineralize the dissolved organic phosphorus, perhaps through condensed poly-phosphates to ortho-phosphate, which is then available for uptake by algae in the next cycle (cf. Leonov and Vasiliev, 1980). In view of the purpose of the present work several simplifications were introduced in order to arrive at the simplest possible model that still represents the major features. First the distinction between particulate and dissolved organic matter was dropped, and the sum of the two was simply called "detritus-phosphorus". By this procedure one non-essential state variable was eliminated. Second, the bacteria were not modelled explicitly. Although there is little doubt about the significant role of bacteria, inclusion of bacteria is not necessary for the present purpose. This statement is based on the argumentation, that bacteria processes are comparatively fast, and mostly governed by the water temperature. Consequently, the effect of a time-varying bacteria population can in first approximation be simulated by introducing a strong temperature dependancy of the mineralization rate (see Appendix I). In addition, no systematic dynamic data exist on the bacteria population (although measurements show an increasing tendency over the years since 1966), and thus possibilities of checking parameter assumptions against field data are lacking.

The_sediment

Like in many other shallow lake systems the sediment constitutes a considerable source of uncertainty. Initially, a simple sediment submodel was included in the model, such that about one-third of the detritus was mineralized in the sediment (oxygen consumption measurements of lake water and sediment core suggest this ratio). Due to a lack of systematic data, this submodel was abandoned for the time being, and replaced by the simplifying assumptions

that continuously sedimentation of (the particulate fraction of) detritus occurs, and that dissolved inorganic phosphorus is released at a temperature dependent but otherwise constant rate. Both sedimentation rate and release rate are essentially unknown, and are therefore treated as "tunable" parameters.

Matching model and observation data representation

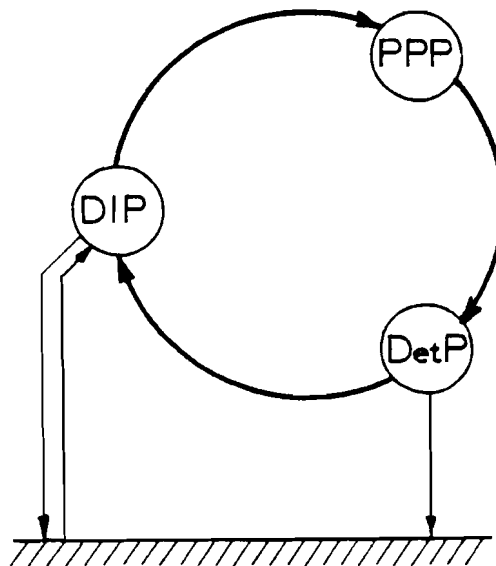

Figure 5. Model I Structure. PPP-Phytoplankton P, DetP-Detritus P, DIP-Dissolved Inorganic P.

Figure 5 presents the structure of model I postulated on the basis of the previous considerations. The model has four state variables: winter algae phosphorus, summer algae phosphorus, detritus phosphorus (both dissolved and particulate) and dissolved inorganic phosphorus. The two algae species are not shown separately. Since this model-intrinsic representation does not match the data type of the measurements, a transformation is necessary both on the input and output side of the model. That is, the various phosphorus loadings have to be allocated to each of the state variables, and the model results have to be expressed in terms of the measurements or vice versa. For the distribution of the phosphorus load the following simplifying assumptions were made:

- (1) all sewage is in dissolved inorganic form
- (2) the Zala dissolved phosphorus load contributes solely to the dissolved inorganic pool (i.e. no detritus fraction)
- (3) the Zala particulate load, as well as the run-off in the other basins (refer to Fig. 3) is divided into an available and non-available part. The non-available fraction is believed to settle directly in the near-shore regions of the lake, so that this part does not show up in the mid-lake measurement data. A strong indication for such a phenomenon to occur is that about 95% of the total phosphorus entering the lake is retained. The available fraction is assumed to contribute to the detritus (because it is particulate, mineralizable matter).

The fraction available phosphorus in the particulate load is, in fact, a model parameter as long as actual measurements (for instance by more detailed chemical fractionation of the Zala P-input) are lacking. The value was set arbitrarily to 10% in the present application. At such low values the model is not very sensitive to this parameter because the majority of the available P-loading is in dissolved form (mainly sewage).

To enable a comparison of model results with actual data also a transformation is needed. There are, principally, two ways of doing this: either by manipulation of the data to yield state variable values (e.g. detritus-P equals particulate organic P minus phytoplankton-P plus total dissolved P minus dissolved inorganic P) or by recombining the model results in terms of the measurements. The latter procedure is preferred because data manipulation results in large relative errors when subtraction of two uncertain numbers is involved, and would also cause problems if the measurements are not complete or asynchronous. Let \underline{y} denote the vector of observations (i.e. chlorophyll, TP (without PIP), TDP and PO_4), and \underline{x} the vector of state variables (winter algae-P, summer algae-P, detritus-P, dissolved inorganic P), then the observation matrix is given by

$$\underline{y} = \begin{bmatrix} C_1 & C_2 & 0 & 0 \\ 1 & 1 & 1 & 1 \\ 0 & 0 & \gamma & 1 \\ 0 & 0 & 0 & 1 \end{bmatrix} \underline{x}$$

where C_1 , C_2 are the chlorophyll-phosphorus ratio of the winter- an summeralgae, respectively, and γ is the fraction of detritus in

dissolved form. Both C_1, C_2 and γ are essentially unknown in the present case. The parameters C_1 and C_2 do not occur in the model itself, so it was decided to leave the results in the form of total phytoplankton-P because a tentative comparison with chlorophyll could always be made afterwards by assuming values for C_1 and C_2 without affecting the other model results. It should be noted that a very important implication of the lack of information on C_1 and C_2 is that one cannot hope to make accurate statements about the dynamics of the algal growth and mortality from a comparison of model results with measurement data. In the present application this problem is less serious because the principle aim is to investigate the major phosphorus transport modes to or from the sediment, for which a rough estimate of the algal levels suffices. The situation is different with respect to parameter γ , which also occurs in the model itself (settling only operates on the particulate fraction $(1-\gamma)$ of the detritus). This is, in fact, the price that must be paid for the reduction of the number of state variables by combining particulate and dissolved non-living P into one detritus term. An estimate for the value of γ is obtained from Table I as 0.4 by comparison of dissolved organic P (11 mg P/m³) with the non-algae part of the particulate organic P ($22 - 0.5 * 14 = 15$ mg P/m³, where average chlorophyll-P is 14 mg/m³ and chlorophyll-P ratio is 2, see below).

Results for Model I

Extensive experimentation with model I revealed an important deficiency. Figure 6 shows a typical pattern of dissolved inorganic phosphorus obtained with this model, for Keszthely Bay. Data points are also shown. Most striking is the rapid rise of DIP in the model at the end of the year, which conflicts with the actual observations. In this model the major mechanism to keep the ortho-phosphate levels low against continuous loading is the uptake by algae. Since this uptake ends rather abruptly about mid September, when temperature and light sharply decline, no removal mechanism is active in the model, and DIP rises rapidly. Similar arguments apply to the period in May after the decline of the spring bloom. No improvement could be obtained by modification of the mineralization rate term, because the contribution of mineralization of decaying algal biomass was

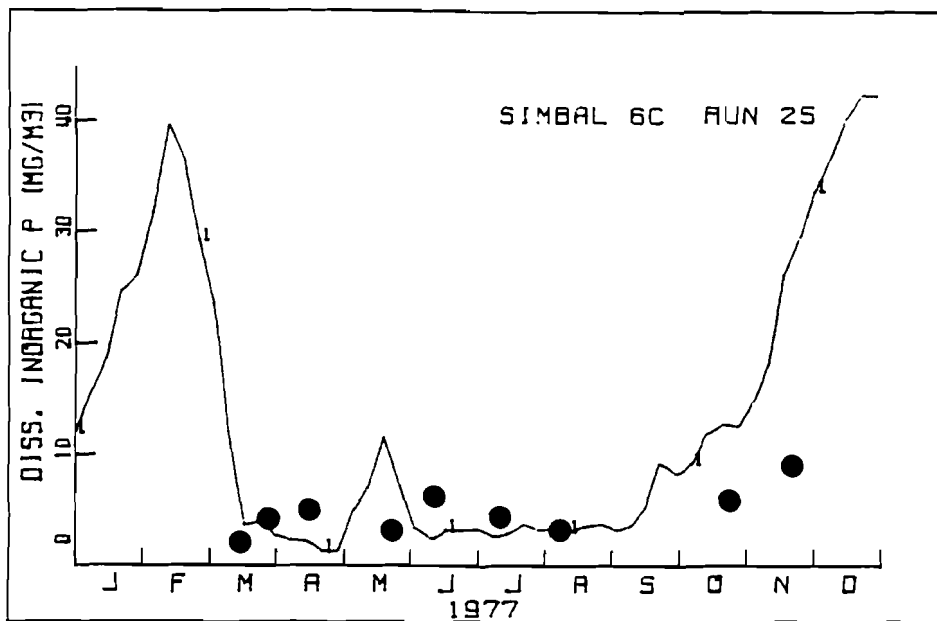

Figure 6. Typical result for model I. Comparison of simulation (solid line) with measurements (dots) for dissolved inorganic P in Keszthely Bay (Basin I)

only a fraction of the phosphorus loading. The results from model I strongly suggest that another mechanism exists to regulate the ortho-phosphate levels.

The sorption hypothesis

The chemical composition of the Balaton would certainly allow for an appreciable phosphorus coprecipitation with biogenically formed lime. This was accounted for in model I (see Appendix I). However, biogenic lime formation is bound to the growing season, whereas the results suggest that phosphorus adsorption also occurs outside the season. This leads to the hypothesis of a continuous adsorption-desorption process. The sediment may play a direct role in this process, but it is perhaps more likely that sorbents are continuously present and renewed by steady resuspension and settling of sediment particles into and from the water.

The proper implementation of the sorption hypothesis would require the formulation of a sorption isotherm model, assuming that the

adsorption/desorption is fast. First experimentation with such a model revealed as most serious problem the need to know the amount of (active) sorbents. Consequently, a dynamic model of suspended solids with phosphorus adsorption capacity would have to be made. Although recent data material is available from which such a model could probably be prepared (Somlyódy, 1980), another way was chosen here as a first approximation.

In model II the sorption reaction was postulated as a dynamic process:

$$\dot{DIP} = -RKSOR * (DIP - DIPEQ)$$

From the data it was clear that the equilibrium concentration DIPEQ could not be far away from the actual DIP concentrations observed. The relatively heavy loading in the Keszthely Bay is likely to cause a relatively high phosphorus density on the available sorption surface. Consequently, the equilibrium concentration would have to be different from basin to basin. Provisionary, the ratio of the average particulate inorganic P from basin to basin was used as an indication for the ratio in DIPEQ, as shown in Table 2.

Table 2. Ratio of DIPEQ based on PIP ratio

basin	I	II	III	IV
PIP (mg/m ³)	10.3	8.3	6.7	4.4
ratio	1	0.8	0.65	0.4

The structure of model II is schematized in Figure 7.

Monte Carlo simulation with model II

A Monte Carlo simulation was performed to investigate whether parameter regions existed for which model II would give results that coincided with a predefined behaviour derived from the data. The behaviour definition used is given in Table 3.

It was decided not to vary all parameters in the simulation in order to reduce the number of runs required. At first, a serie of 300 runs was done, varying nine parameter values according to Table 4. These were mostly parameters governing the sediment-water interaction.

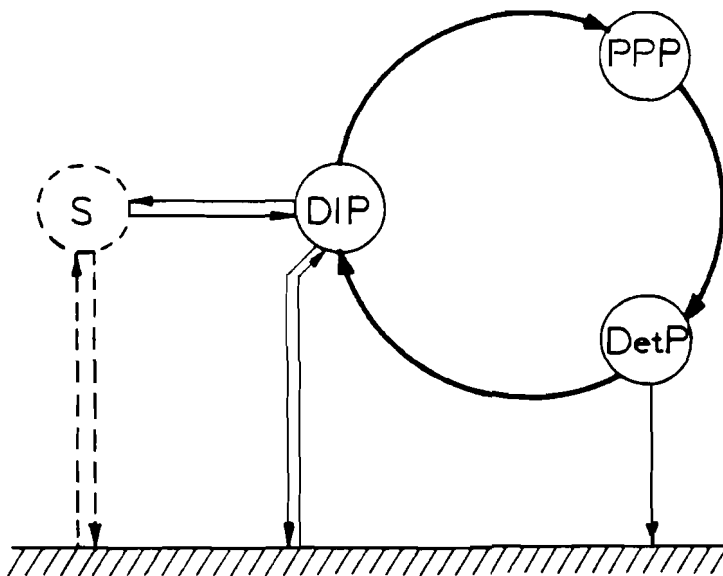

Figure 7. Model II structure with sorption hypothesis.
S-Sorbens (not modelled explicitly)

Table 3. Behaviour definition

Period	Variable		Range
15 MAR - 22 NOV	TP	I	49.5 - 110.0
		II	31.5 - 82.5
		III	13.5 - 60.5
		IV	9.0 - 49.5
20 MAY - 8 AUG	TDP	I	13.5 - 55.0
		II	13.5 - 38.5
		III	9.0 - 33.0
		IV	4.5 - 27.5
15 MAR - 22 NOV	DIP	I	0 - 16.5
		II	0 - 8.8
		III	0 - 8.8
		IV	0 - 8.8

The temperature factor for algae mortality was also included to allow for a reduction or increase of mortality of cold water algae, which might influence the speed of phosphorus regeneration after the algae blooms.

Table 4. Parameter Ranges

Parameter	Range			
	Serie 1		Serie 2	
VRET Horiz. exch. flow (m/s)	0	- 0.003	0	- 0.003
PK Monod Constant (mg P/m ³)	7	- 13	7	- 13
DTR Mort. rate temp. effect	1.05	- 1.15	1.09	- 1.15
ENOM Miner. rate (1/day)	0.02	- 0.08	0.02	- 0.06
SETTV Net settling vel. (m/day)	0.01	- 0.07	0.01	- 0.05
BLP Biog. lime coprec. (m ³ /mg)	0	- 0.03		0.015
RELES Release from sed. (mg/m ² day)	0	- 1.0	0	- 1.0
RKSOR Sorption rate (1/day)	0	- 0.5	0	- 0.2
DIPEQ Equilibrium conc. (mg P/m ³)	5	- 9	5	- 9

Out of the first series of 300 runs only one parameter combination was found that gave rise to the behaviour, despite the fact that the constraint conditions were rather wide. One reason is that random and independant parameter selection ignores that some of the parameters of the model must be correlated in order to keep the state variables within a certain range. For instance, from the model equations (see Appendix I) it can be seen that ENOM and SETTV must be negatively correlated if the detritus is to be within certain limits. All parameter combinations generated outside this correlation region will not yield the behaviour.

An analysis of the position of ENOM and SETTV for runs for which the constraints were partially fulfilled (i.e. TDP and DIP behaviour, but not TP behaviour) showed that ENOM and SETTV were confined to one corner of the parameter plane. Thus a reduction of the parameter region would be possible to increase the efficiency of the computation. Another interesting result of the first series was obtained from analysis of the position of RKSOR and DIPEQ for partial behavioural runs. Figure 8a shows the runs resulting in TP behaviour (but generally not TDP and DIP behaviour), and Figure 8b the runs resulting in TDP and DIP behaviour (but not TP behaviour). It became very apparent that in order to fulfill the total P conditions RKSOR has to be low. This is because a rapid sorption rate would result in rapid phosphorus desorption in the summer period, leading to higher

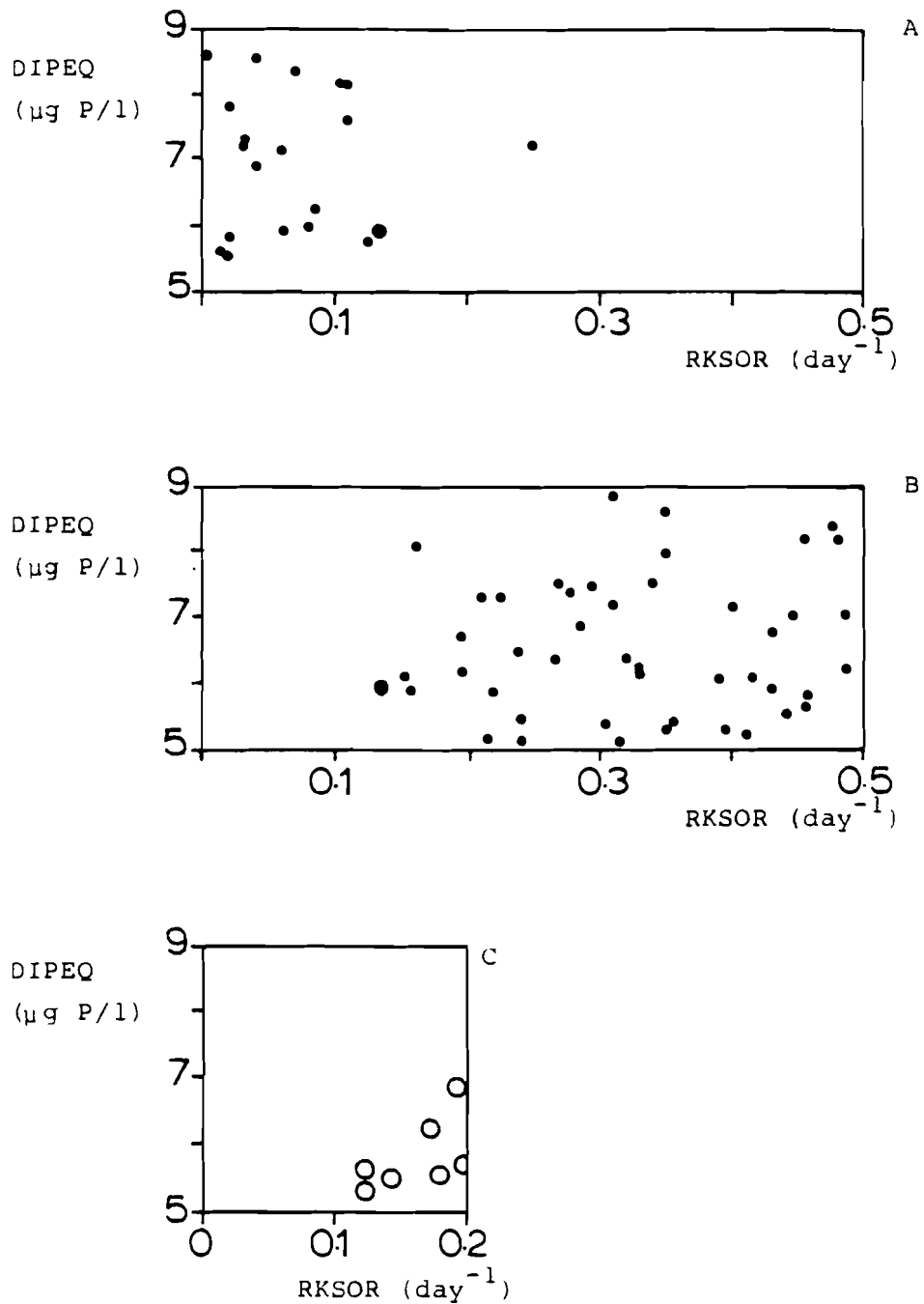

Figure 8. Monte Carlo simulation results for distribution of equilibrium concentration (DIPEQ) and sorption rate (RKSOR)
A. Runs with total phosphorus behaviour (serie 1)
B. Runs with total dissolved and dissolved inorganic phosphorus behaviour (serie 1)
C. Full behaviour runs (serie 2)

algal growth and, consequently, to too much total P, whereas in autumn and winter phosphorus would be removed too rapidly. On the other hand RKSOR can not be too low, because this would lead to insufficient adsorption in autumn and, thus, a violation of the TDP and DIP conditions.

A second serie of 300 runs was done after modification of the parameter ranges resulting from the first series analysis. The RKSOR range was reduced, biogenic lime coprecipitation taken constant because the model was insensitive to this parameter, and ENOM and SETTV were reduced as discussed previously. With these more limited parameter ranges the second series of 300 runs yielded 7 parameter-sets that fulfilled the behaviour constraint conditions. In Figure 8c the position of these runs in the DIPEQ-RKSOR plane are indicated. Table 5 summarizes the mean and range found for the parameters involved. The results confirm that RKSOR must assume intermediate values, but, as is seen from Figure 8c there is a correlation with

Table 5. Parameter properties behavioural runs (serie 2)

	Min.	Max.	Mean
VRET	0.0002	0.0024	0.0016
PK	8.2	11.2	10.2
DTR	1.10	1.15	1.14
ENOM	0.030	0.047	0.035
SETTV	0.026	0.050	0.036
RELES	0.12	0.71	0.38
RKSOR	0.12	0.20	0.16
DIPEQ	5.3	6.8	5.8

the value of DIPEQ. As expected also ENOM and SETTV are correlated. A number of seven behavioural runs is too low for a proper statistical analysis, but for some parameters behaviour is possible for very specific regions in parameterspace only, whereas others can take on various values (e.g. RELES). The role of the longitudinal exchange rate parameter VRET is not clear from the results; both a high and a low longitudinal mixing could produce the behaviour provided a suitable value for the other parameters.

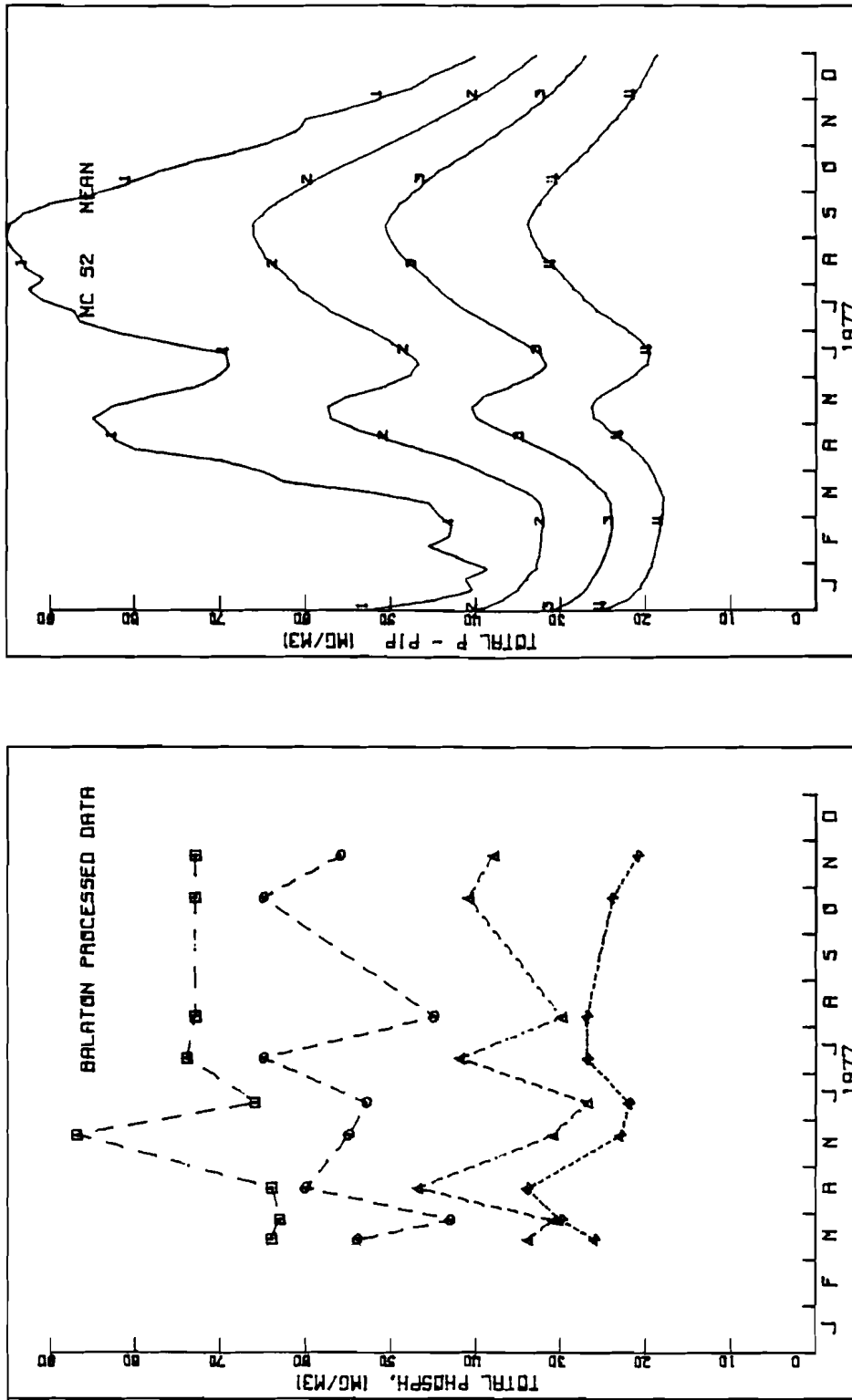

Figure 9a. Total phosphorus data (left, particulate inorganic P subtracted) and average of the 7 behavioural runs (serie 2) for the four basins

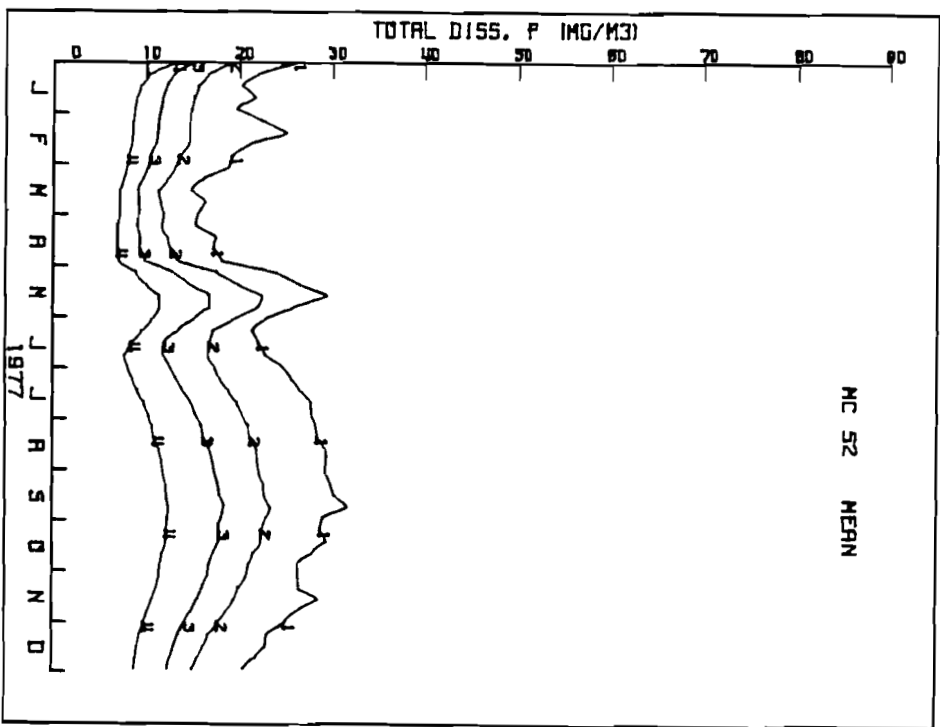
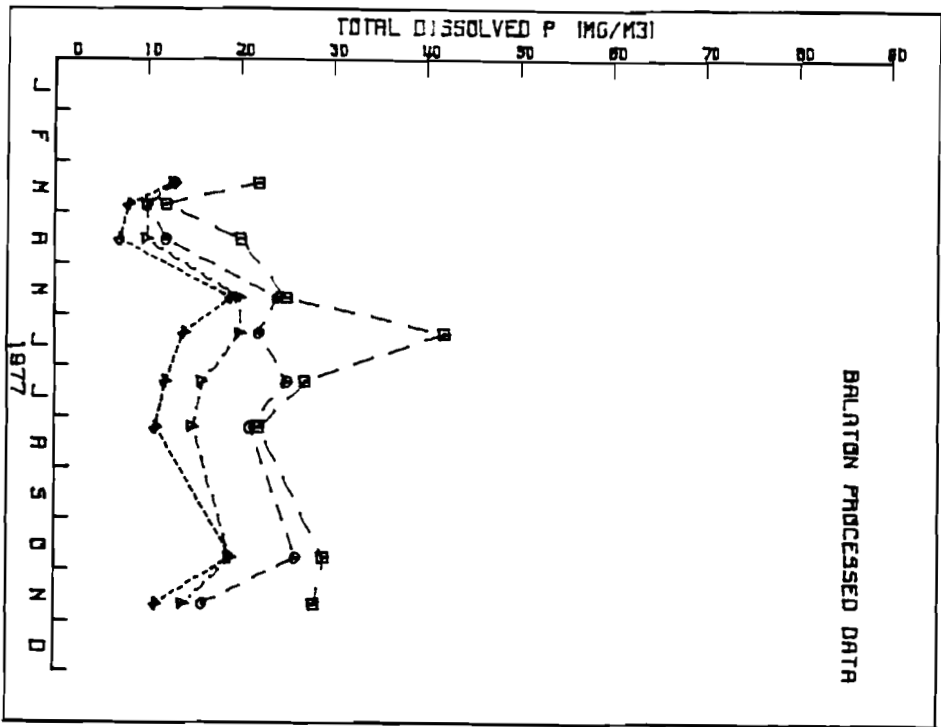

Figure 9b. Total dissolved phosphorus data (left) and average of the 7 behavioural runs (serie 2) for the four basins

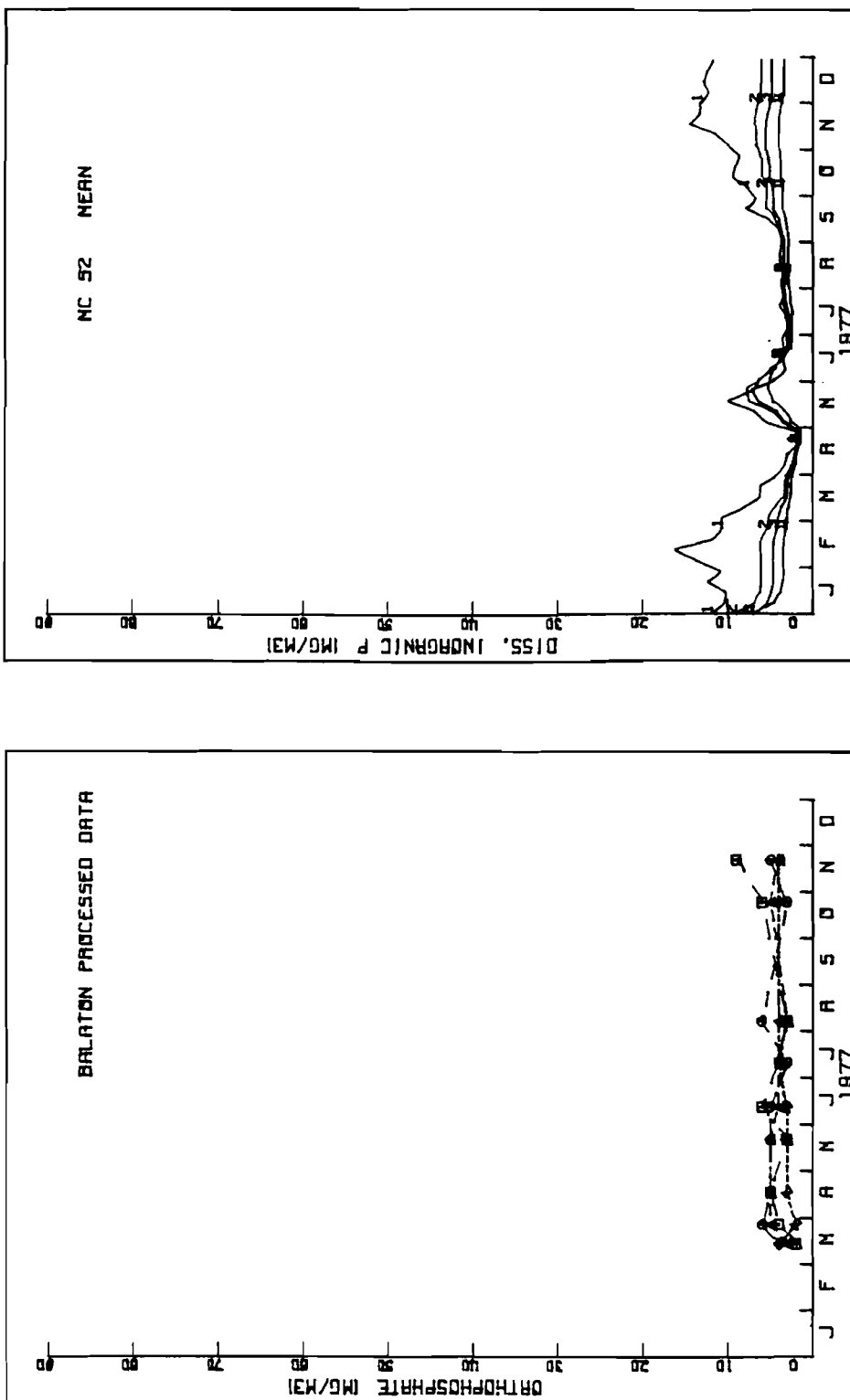

Figure 9c. Orthophosphate data (left) and average of the 7 behavioural runs (serie 2) for the four basins

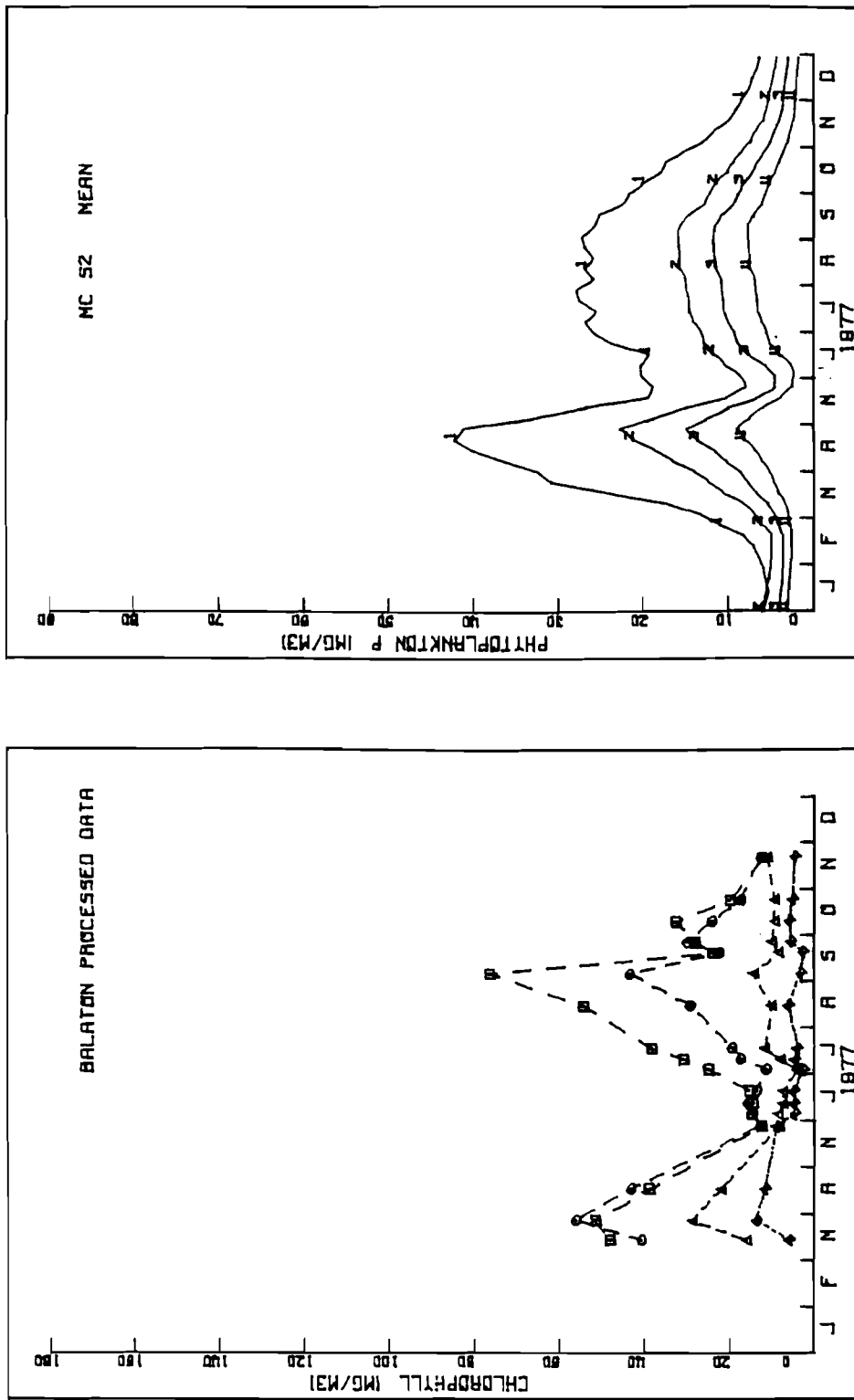

Figure 9d. Chlorophyll data (left) and average of phytoplankton phosphorus of the 7 behavioural runs (serie 2) for the four basins (Note the difference in scale units)

Discussion

In order to obtain a visual impression of the quality of the model results obtained from the second series the mean over the seven behavioural runs was computed for every state variable on each time instant. The curves are shown in Figure 9 together with the actual data for each of the basins. Although not shown in the Figure the lines have to be seen as the approximate centre of a probability density function rather than deterministic curves. It is interesting to mention that almost the same curves are found when the model is run with the average values of the parameters from the seven runs. In other words, the average parameter set is also a behavioural parameter set.

Looking at the curves in more detail shows that total phosphorus in summer has a tendency to be too high. A run without sediment release yielded roughly 10 mg P/m^3 less in all basins, without much effect on phytoplankton or dissolved P. Apparently, in the sorption model, there is no need to take release from the sediment into account separately. On the other hand the sorption model seems to be too simple, because the variability of the total phosphorus is much larger in the model than in the lake. In the model detritus decreases rapidly at the end of the season, even when mineralization becomes slow due to the low temperatures, because of settling. The data suggests a built up of particulate detritus material by the end of the season which is not shown in the model. One possibility is that settling of particulate detritus material is a function of the biogenic lime formation, so that settling is rapid in summer and slow in winter. This additional hypothesis needs verification by further model and field experiments.

Finally, the phytoplankton patterns need some discussion. At first sight the results do not look very good. However, as pointed out previously, no direct comparison with chlorophyll data is possible. The results indicate that generally the chlorophyll to phosphorus ratio is about 2 or somewhat higher. The spring peak in the model is slightly higher than the summer peak, which agrees with the data except for the first basin. Here, most likely the dominant role of the blue-green algae, not contained explicitly in the model, dis-

turbes the picture. It is also clear that the phytoplankton levels between the two blooms is higher in the model than in reality. An improvement can doubtlessly be made on the basis of primary production measurement results for 1977, mainly through modification of the algal growth temperature dependancy parameters. In the model summer algae growth starts by the end of June, which is several weeks earlier than in the lake. It is not clear why this retardation occurs, because light, temperature and phosphorus conditions are good in those weeks.

Conclusions

It is likely that a sorption mechanism, leading to desorption of phosphorus during algal growth, when dissolved inorganic P is low, and a strong adsorption outside the growing season, occurs in the lake. It is desirable to repeat the analysis for 1976, a year with a different loading pattern and less pronounced algal growth. In addition it is recommended that proper sorption experiments be done with lake water and lake sediments to confirm or deny the existence and significance of the sorption process. Although systems analysis by model studies is very often the only way to utilize the information contained in the data at hand, only additional field investigations could provide the final answers on remaining questions.

APPENDIX I

Model equations

PPPW = I/O + RGRW - RTDHW

PPPS = I/O + RGRS - RTDHS

DETP = I/O + ΣRDTH - RMNRL - RSETL

DIP = I/O - ΣRGR + RMNRL - RBIOP + RREL + ΣL - RSOR

Inflow/outflow: see Figure 4

Growth: RGR = FP * FL * FT * PMAX * PPP

- Monod term

FP = DIP/(PK + DIP)

- Light limitation (Steele's equation averaged over depth and over the day with triangular light pattern)

EPSØ = extinction of water (forcing constant)

H = depth (constant)

R = daysum radiation (forcing function)

L = length of photoperiod (forcing function)

EPS = EPSØ + SELSH * PPP

EH = EPS * H

ROPT = ROM + ROE * T

RØ = R/ROPT

RH = RØ * EXP(-EH)

FØ = (1 - EXP(-2 * RØ/L))/RØ

FH = (1 - EXP(-2 * RH/L))/RH

C = EXP(1) * L ** 2/2 * EH

FL = C * (FØ - FH)

- Temperature dependancy

T = temperature

winter algae:

CW = |(TCRITW - T)/(TCRITW - TOPTW)|

FTW = CW * EXP(1-CW)

summer algae:

CS = (TCRITS - T)/(TCRITS - TOPTS) if T < TCRITS
= 0 if T > TCRITS

FTS = CS * EXP(1-CS)

Mortality:

RDTH = DNOM * DTR ** (T - 20) * PPP

Mineralization:

RMNRL = ENOM * ETR ** (T - 20) * DETP

Settling:

RSETL = SETTV * (1 - GAMMA) * DETP/H

Biogenic Precip.:

RBIOP = BLP * RGR * DIP

Release:

RREL = RELES * SETR ** (T - 20)/H

Particulate load:

PPLZ = Z_p in Figure 3

D = see Figure 3

RPLD = PPLZ * D * ALFA/V

Dissolved loads:

ΣL = PRL + SEWLD

PRL = precipitation load (forcing function)

SEWLD = sewage load (see Figure 3)

Sorption (in model II only):
 $RSOR = RKSOR * (DIP - DIPEQ)$

Parameters

Exchange flow velocity	VRET	see text	
Monod constant phosphate	PK	see text	
Base extinction coefficient	EPSØ	I :	3.2 1/m
		II :	2.7 1/m
		III:	2.2 1/m
		IV :	1.8 1/m
Selfshading	SELSH	0.015	m ² /mg P
Optimal light intensity	ROM	96.0	cal/m ²
	ROE	9.6	cal/C m ²
Critical temperature	TCRITW	10	C
	TCRITS	30	C
Optimal temperature	TOPTW	8	C
	TOPTS	26	C
Maximum growth rate	PMAXW	2	1/day
	PMAXS	6	1/day
Mortality rate	DNOM	0.13	1/day
	DTR	see text	
Mineralization rate	ENOM	see text	
	ETR	1.18	
Net settling velocity	SETTV	see text	
Fraction detritus dissolved	GAMMA	0.4	
Biog. lime precip.	BLP	see text	
Release from sediment	RELES	see text	
	SETR	1.18	
Available P in load	ALFA	0.1	
Sorption rate	RKSOR	see text	
Equilibrium concentration	DIPEQ	see text	

ratio over the basins, see Table 2

REFERENCES

- Beck, M.B., E. Halfon, and G. van Straten. "The Propagation of Errors and Uncertainty in Forecasting Water Quality - Part I: Method". Working Paper WP-79-100, September 1979. International Institute for Applied Systems Analysis, Laxenburg, Austria.
- Di Toro, D. and G. van Straten. "Uncertainty in the Parameters and Predictions of Phytoplankton Models". Working Paper WP-79-27, April 1979. International Institute for Applied Systems Analysis, Laxenburg, Austria.
- Entz, B. "Chemische Charakterisierung der Gewässer in der Umgebung der Balatonsees (Plattensees) und chemische Verhältnisse des Balatonwassers". Annal. Biol. Tihany. Vol. 26, 1959: 131-201.
- Fedra, K., G. van Straten and M.B. Beck. "Uncertainty and Arbitrariness in Ecosystems Modelling: A Lake Modelling Example". Working Paper WP-80-87, May 1980. International Institute for Applied Systems Analysis, Laxenburg, Austria.
- Herodek, S. "Recent Results of Phytoplankton Research in Lake Balaton". Annal. Biol. Tihany. Vol. 44, 1977: 181-193.
- Leonov, A.V. and O. Vasiliev. "Simulation and Analysis of Phosphorus Transformation and Phytoplankton Dynamics in Relation to the Eutrophication of Lake Balaton". Working Paper WP-80-88, May 1980. International Institute for Applied Systems Analysis, Laxenburg, Austria.
- P.-Zánkai, N. and J. Ponyi. "Seasonal Changes in the Filtering Rate of *Eudiatonus gracilis* (G.O. Sars) in Lake Balaton". Annal. Biol. Tihany. Vol. 43, 1976: 105-116.

Somlyódy, L. "Preliminary Study on Wind Induced Interaction Between Water and Sediment for Lake Balaton (Szemes Basin)". In G. van Straten, S. Herodek, and J. Fischer (editors): Proceedings of the 2nd joint MTA-IIASA Task Force Meeting on Lake Balaton Modeling. Veszprém, August 27-30, 1979.

Spear, R.C. and G.M. Hornberger. "An Analysis of Behaviour and Sensitivity of a Poorly-Defined System". Report AS/R24, 1978. Centre for Resource and Environmental Studies, Australian National University.

Van Straten, G., G. Jolánkai, and S. Herodek. "Review and Evaluation of Research on the Eutrophication of Lake Balaton - A Background Report for Modeling". Collaborative Paper CP-79-13, August 1979. International Institute for Applied Systems Analysis.