



Mathematical Approach to Developing a Simulation Model of a Health Care System

Klementiev, A.A.

**IIASA Research Memorandum
August 1976**



Klementiev, A.A. (1976) Mathematical Approach to Developing a Simulation Model of a Health Care System. IIASA Research Memorandum. Copyright © August 1976 by the author(s). <http://pure.iiasa.ac.at/619/> All rights reserved. Permission to make digital or hard copies of all or part of this work for personal or classroom use is granted without fee provided that copies are not made or distributed for profit or commercial advantage. All copies must bear this notice and the full citation on the first page. For other purposes, to republish, to post on servers or to redistribute to lists, permission must be sought by contacting repository@iiasa.ac.at

MATHEMATICAL APPROACH TO DEVELOPING A
SIMULATION MODEL OF A HEALTH CARE SYSTEM

A. Klementiev

August 1976

Research Memoranda are interim reports on research being conducted by the International Institute for Applied Systems Analysis, and as such receive only limited scientific review. Views or opinions contained herein do not necessarily represent those of the Institute or of the National Member Organizations supporting the Institute.

PREFACE

Persons responsible for making managerial decisions, on a national level, concerning health care systems face the necessity of making decisions whose consequences--probably negative--would appear only 10-20 years after the decisions have been made. It is not always possible to envisage or to evaluate those consequences in a quantitative way. Theoretically, health care system models and the modelling process itself can provide health planners with valuable information and with new ideas for a more proper understanding of the system's behavior under the alternative policies tested.

A simulation approach to health care activities is presented in this paper. Some definitions, general structure and mathematical descriptions are given. This paper constitutes a part of the research work on health care system analysis, undertaken due to the initiative and under the guidance of Professor D.D. Venedictov, conducted by an international team at IIASA and by the national group on health care modelling in the USSR.

This paper is an interim report on the said subject.



ABSTRACT

This paper describes some needs and methods of health care modelling. It contains a general approach and the first version of a mathematical description of the processes within a health care system. Definitions of terms used in the paper are also given. Some mathematical tasks, specific for the practice of health care management, are set.

Mathematical Approach to Developing a Simulation Model of a Health Care System

The need for a systems approach in the study of such a comprehensive dynamic object as the health care system (HCS) has often been written about [1]. The present paper is a development of the point of view described in a series of works. Here, the meaning of a "health care system dynamic imitation model" (HSDIM), as well as its structure, definition and methods of development, are described.

THE GENERAL DIRECTION FOR THESE WORKS

Recently, a substantial increase in the population's demand for qualified medical care has been noted [1,2,3,5]. This tendency has been connected with an increase in living standards, environmental pollution, urbanization and other factors. An increase in the demand for medical services has placed new demands on the use of HCS resources. Therefore, the task presents itself to so organize a population's medical services at the level of a large region (for example, a country-wide region) so that the medical needs of the population of that region may be best satisfied.

The specific feature of HCS management is that the consequences of managerial actions might appear 10-15 years after a corresponding decision has been made. A present-day manager is unable to foresee and, at times, to estimate all possible consequences because of the complexity of the object itself, the dependency of the object's behavior on the environment, etc. Under these conditions it has often proved difficult to reach the best (or even a merely acceptable) decision. Imitation of the development of an actual health care system by means of a model allows one to establish (in general outline) the tendency for this system's development as a function of:

- acceptable management policies; and
- possible behavior of the outer subsystems.

By studying the model's behavior, a basis is provided for managerial decision making.

In the present work, the development of HCS is understood as follows:

1. Changes in the general volume and proportions of HCS resources (labor resources in particular) due to changes

in the size of population, in the structure of disease prevalence, in methods for disease prevention and treatment, and so on.

2. Change of the normative base due to progress in medical science which influences methods of treatment and prevention.
3. An increase in the role of preventive care activities as a part of the general HCS activity.

Synthesis of the HSDIM presupposes the creation of a mathematical model for the above-mentioned three interconnected aspects of development, elaboration of a set of programs for this model and also a procedure for the interaction of a decision maker (DM) with HSDIM under a dialogical regime.

SOME DEFINITIONS

Let us consider a specific disease and introduce the following definitions:

The number of occurrences of a disease per 1,000 persons for one calendar year is called the morbidity rate of the disease.

The total number of patients with this disease at any given moment is called the prevalence of the disease for that moment. Not all sick persons utilize medical services immediately after the first appearance of a disease. Therefore, only a portion of all sick persons is within the sphere of the health care system. This portion constitutes the registered prevalence of the disease. The remaining portion of sick individuals constitutes the unregistered or latent prevalence of the disease.

In developing the HSDIM, three different versions, corresponding to three essentially different types of disease, have been elaborated.

Type I Diseases are characterized by a weak, often unnoticed onset of the disease and a long development time which exhibits the following characteristic phases:

Phase A: the patient is capable of working. The signs of the disease may not be noticed subjectively. This is the initial period of the disease. Treatment during this phase may be effective, i.e. lead to recovery.

Phase B: the patient loses his ability to work either temporarily or partially. The course of the disease is of a steady nature. Treatment during this phase may be effective, returning the disease to Phase A.

Phase C: the patient has a fixed inability to work. There are irreversible pathological changes in the organism.

Alcoholism and certain malignant tumors may be considered as examples of a Type I disease.

Type II Diseases include those acute infectious diseases for which vaccination is available. Examples are smallpox, poliomyelitis, etc.

Type III Diseases are characterized by the absence or ineffectiveness of early diagnosis and the impossibility of immunization. Examples include accidents and poisoning.

Let us determine the main aspects of HCS activity taken into account by the HSDIM.

Treatment Activity is represented in the HSDIM as the interaction of registered patients with HCS resources. As a result of this interaction, there is consumption of certain resources and a change in the dynamics of the prevalence of the disease.

Activities of preventive medicine are represented in the HSDIM in two aspects:

- 1) screening and processing to identify and treat sick individuals;
- 2) vaccination of the healthy population.

In both cases, some HCS resource is consumed and the structure of the prevalence of the disease is changed.

The following types of administrative activity are studied in the HSDIM: staffing policy, population screening policy, policy for health standards.

Staffing policy designates management decision making about size and proportions for staffing resources (doctors). At the same time, corresponding norms would allow one to calculate, if necessary, on the basis of the number of doctors and other kinds of resources being used (beds, nurses, etc).

Choice of a rational population screening policy is formulated largely on the following considerations. On the one hand, increase in the number of first-time "light" patients, i.e. patients with the initial signs of a disease. Since treatment of "light" patients is more effective*, the HCS's treatment activities become more effective. On the other hand, increase in screening leads to increased expenditures in the screening efforts

* Later we will discuss criteria for effectiveness. Here, effectiveness may be understood as the cost of treatment.

themselves. Thus information of a rational screening policy involves a certain compromise--a choice of the screening program's scale while taking into account other, not necessarily financial, criteria.

A policy for health standards requires regular updating of HCS standards. This updating is to establish rational proportions between various kinds of HCS resources on the one hand, and the changing structure of population health care requirements on the other. This updating also takes into account advances in the field of medical science.

The following kinds of resources are taken into account by the HSDIM:

1. Technical resources for preventive care, measured by financial expenditures for the preventive care capability.
2. Physician-manpower resources for preventive care activities.
3. Physician-manpower resources for outpatient services.
4. Physician-manpower resources for hospitals.

Resources 2, 3 and 4 are measured both as natural indicators, i.e. the number of physician-days expended in the HCS for a corresponding activity (preventive care, outpatient service, hospitalization), and as cost indicators, i.e. financial expenditures on a corresponding activity.

Management policy is understood here as simulation of administrative activities in the DM-HSDIM dialogue.

Effectiveness criteria of the selected management policy are those HCS development indicators essential for the DM. It is assumed that the DM selects a management policy in order to "improve", in some sense, these indicators. The list of criteria is assigned by the DM himself.

DESCRIPTION OF THE MODEL

In the present work, a HSDIM variant is presented in which processes of the real HCS, specific only for Type I diseases, are simulated. A general structural scheme of the model is presented in Fig. 1. Such environmental characteristics (1) as living standard, educational level, climate, food quality, etc. influence both the sex-age structure of the population (2), and the incidence of disease in these sex-age groups (3). In turn, the sex-age structure and the incidence of disease determine the prevalence of disease for the population (4). The latter also depends on the HCS's treatment/preventive care activities (5). Disease prevalence is treated as demands of the population

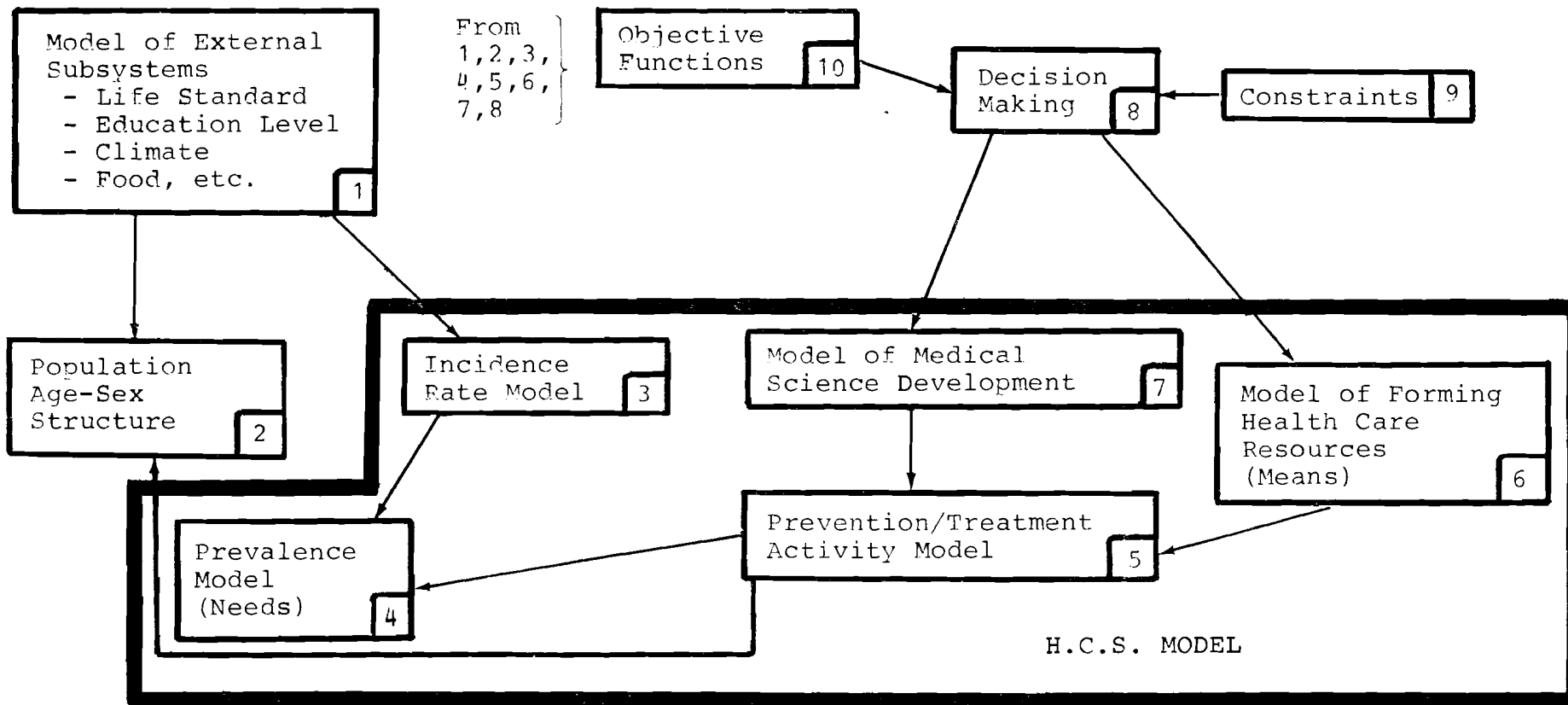

Figure 1.

on HCS treatment/preventive care resources. Organization of these resources (treatment/preventive activities) takes place according to HCS norms. As a result of resource consumption, the disease prevalence structure changes. Characteristics defining the quality of treatment/preventive care activities depend on the level of medical science (7). Such characteristics of the model are time and cost of treatment in a corresponding phase, cost of a single screening examination, etc.

At this level of development, there is no study in the model of HCS management processes. If one wished to study HCS management processes, then the model could be used in the dialogue: DM-model. In this case, the DM (8) determines the HCS development goal and formulates corresponding demands on the effectiveness criteria (10). Next, he formulates some management policy, taking given resource constraints (9) into account, and he may also suggest certain general hypotheses about the environmental state. This information is then formalized, taking into account the peculiarities of the model. The model's behavior under assigned conditions is played on a computer. Results of these computations are given to the DM for analysis of the quality of the selected management policy.

Let us now turn to a description of the first version of the model. It is presented as a flow-diagram in Fig. 2. Here the entire population is presented as three groups, each of which is divided into strata according to sex, age and phase of disease. In group HP is the healthy population; in group LD - latent sick individuals; and in group RP - registered patients, i.e. those individuals utilizing the resources of the health care system. Data update for the strata takes place at each time step, whose time interval is equal to one month. The population dynamics within the groups, and also among strata, is represented by equations (1)-(3)*. Transition from group LD to group RP is carried out depending on how corresponding health care resources, ADR (15), become available (either by being free from earlier demands or increased in number) and is determined by the variable REAP (18). The part of the population requesting medical care, AAS (17), is formed by the number of sick individuals who ask for treatment on their own, AT (7), and latent sick revealed through screening, SD (9). The general productivity of screening (the number of the population from groups LD and HP having undergone screening, per unit time) depends on how well the screening service is equipped, ARS (21), and the general physician-manpower resources of this service, SDH (11). The proportions between treatment, TDH (12), and preventive care services, SDH (11), for physician-manpower resources are denoted by the variable TSP, which is assigned by the DM. Proportions between outpatient and inpatient physician-manpower resources are denoted by the variable ATDH. Physician-manpower resource capacity (involved

* Below in parentheses is indicated the number of the equation which describes the dynamics of the corresponding variable. The system of equations is given in Appendix 2.

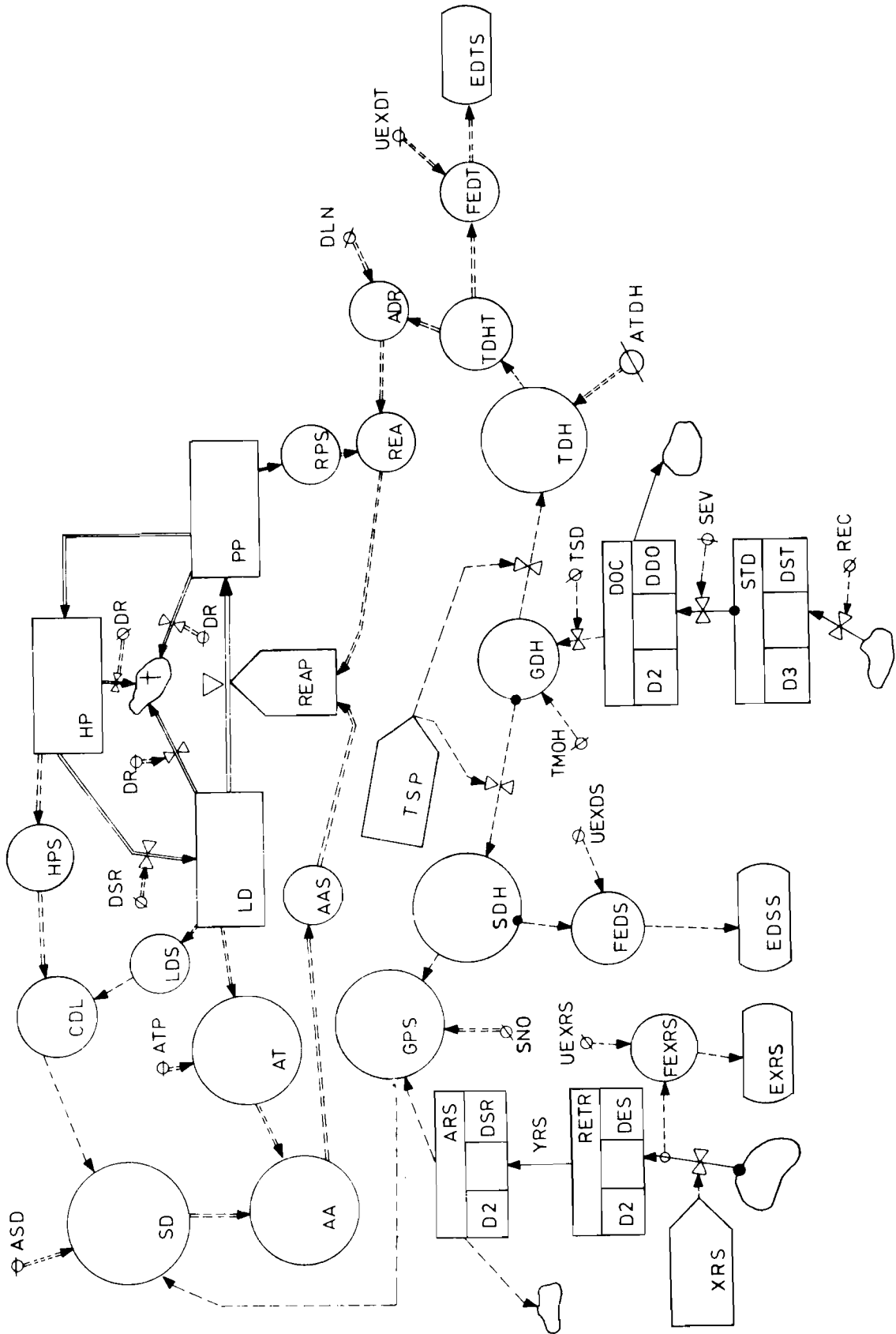

Figure 2. Flow Diagram of the Model: First Version

in treatment activities only), as represented by physician work load norms, is given by the variable ADR (15). Unutilized treatment resources (due to unutilized portions of physician work load) are expressed by REA (16). In the model, time delays connected with the training of physicians (STD), the departure of physicians from the HCS with the cessation of their professional activities, and also delays in delivery of technical resources for screening operations (RETR) (20) are taken into account. Current and total (for the interval of time under study) HCS expenditures are presented by the following variables: FEXRS, PEDS, PEDT--current; and EXRS, EDSS, EDTS--total.

TASK-SETTING

Instances of specific task-setting and the results obtained will be discussed in subsequent publications. Here, for the sake of illustration, an example of a possible situation is given.

Let the cost of treating one patient for a unit of time in phase A of a Type I disease be represented by C_A , in phase B by C_B , and in phase C by C_C . Let us take $[0, T]$ as the interval of time for which the behavior of the system is studied. In a unit of time $v \in [0, T]$, the health care system has A patients detected - $P_A(v)$, B patients - $P_B(v)$ and C patients - $P_C(v)$. The cost of their servicing per unit of time is equal to the following:

$$S_1(v) = (C_v, P_v) \quad ,$$

where

$$C_v = \left(C_A(v), C_B(v), C_C(v) \right) \quad ,$$

$$P_v = \left(P_A(v), P_B(v), P_C(v) \right) \quad ,$$

and (\cdot, \cdot) denotes the scalar product of two vectors.

Total expenditures of the health care system on treatment during the period $[0, T]$ will be as follows:

$$S_1^T = \sum_{v=1}^{T/\nu} (C_v, P_v) \quad .$$

With the increase in the volume of preventive screening, there is an increase in the related expenditures:

$$S_2^T = \sum_{v=1}^{T/v} C_v^S \cdot P_v^S ,$$

where

P_v^S is the number of the population subject to preventive screening; and

C_v^S is the cost for a preventive screening in a unit of time.

However, with the increase in the volume of preventive screening, there must also be an increase in the proportion of detected patients to the overall number of patients. If we are to determine $D_A < C_B < C_C$, it may happen that an increase in S_2^T in a certain interval of time leads to a decrease in S_1^T . Moreover, it may happen that with an increase of S_n^T there is a drop in the total amount of expenditures on treatment and prevention $S^T = S_1^T + S_2^T$.

The task is to determine, taking C_A, C_B, C_C, C as concrete values and presupposing certain tactics for preventive screening:

- at what value of $S_2^T = S_2^{T*}$ the overall expenditures S^T prove minimal;
- what is the influence of S_2^T on other indices of the efficacy of activity of a health care system, for example, on those relating to general mortality, the proportion of recoveries, general morbidity and morbidity in phases, etc.

This example also illustrates that the making of decisions in selecting an acceptable policy for preventive screening is done not only on the basis of the cost criteria of preventive activity. Such a situation is typical for a health care system.

WORKING WITH THE MODEL

The interaction of the decision maker and the model takes place in the following manner. The decision maker develops certain hypotheses about the future behavior of the environment, about limitations on management, about certain parameters of the HSDIM. These may be hypotheses concerning trends in birth rates, changes in the dynamics of registered morbidity in connection with the introduction of more effective drugs, trends in

morbidity and so on. The initial hypotheses and the management variants studied are formalized and, together with other initial data, are put into the model. The results of calculations are visualized in the terminals: line-printer, CRT, etc., in accordance with the requirements of the consumer. These results of calculations form the material on the basis of which the decision maker adopts the decisions. In the form proposed, the model for decision making may be regarded as an instrument for investigating various policies in the management of resources in a given branch.

THE DEVELOPMENT DIRECTION

At present the work on the development of the model is concentrated on the detailed mathematical description of the following sectors:

- (a) Dynamics of population prevalence, with the diseases of the first type taken as an example;
- (b) Consumption of HCS resources and its influence on the prevalence dynamics. Special attention is paid to the consumption of HCS resources for preventive care;
- (c) Effects of external subsystems on morbidity rate.

The description of the prevalence dynamics is based on the following hypotheses:

Hypothesis 1: Generally, the prevalence dynamics in the absence of HCS resource consumption is described by the graph:

$$\Gamma_1: H \rightarrow A \rightarrow B \rightarrow C \rightarrow D \quad ,$$

where

H is the healthy condition;

A, B, and C are corresponding phases of a disease; and

D is death.

The time of a patient's stay in any condition,

$$J \in \{A, B, C\} \quad ,$$

is characterized by random time τ_J . The mean values and dispersions of the value τ_J are considered as known and sufficiently well describing the distribution of τ_J .

Hypothesis 2: The prevalence dynamics, in the case when HCS resource consumption takes place, is described by the graph:

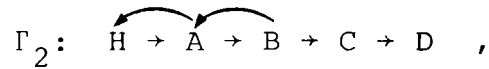

or by the graph:

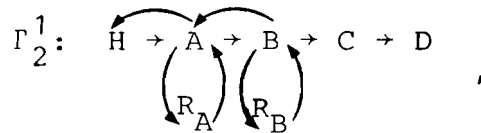

where R_A and R_B are the remission conditions in the phases A and B, correspondingly. The time a patient spends in each of the conditions,

$$J \in \{A, B, C, R_A, R_B\} ,$$

is determined by a random value τ_J^1 . Mean values and dispersions of τ_J^1 values are also considered as known and sufficiently well describing the distribution.

Note 1: Graphs Γ_1 , Γ_2 , and Γ_2^1 do not reflect aging of population and require further detailization.

Note 2: Effects of resource consumption on the prevalence dynamics could be understood as follows:

- Treatment of a patient (i.e. his consumption of HCS resources) allows for his transfer into an easier phase of a disease (for instance, the transfer $A \leftarrow B$). This is impossible if HCS resource consumption does not take place.
- Treatment of a patient allows for a change in the length of his stay in any possible phase of a disease.

Research on the dynamics of population prevalence requires knowledge of the dynamics of the age-sex structure of a population in a given region.

Presently, the development of a computer method for projecting a sex-age structure of a population is over. Mortality

and birth rate are considered as constants there. In further development of the model, the effects of HCS activity on the said parameters will be taken into account.

CONCLUSION

The version of the HSDIM presented here is only a first step in the model development. The subsequent work presupposes:

- a) the development of external subsystems and consideration of their influence on the development of the HCS;
- b) the modelling of development for medical sciences while taking into account its influence on the structure of HCS resources and the effectiveness of treatment and preventive care services;
- c) development of HCS models taking into account the specific character of diseases of Types II and III;
- d) study of the stability of the HSDIM and the solving of a series of partial methodological problems connected with the model's large dimensions, the absence of needed data, and so on.

APPENDIX 1

The following notation is used in the present work:

I - number of sex-age group (stratum), $I = 1, 2, 3$;

J - index of phase of disease incidence, $J \in \{A, B, C\}$;

T - current (present) time.

If FUN is a certain function of the variables (I,J,T), then the notation FUN(I,J,T) everywhere below should be understood as the value of FUN at the moment in time T for the sex-age group I for stage J of the disease.

Specification of Basic Variables

- HP(I,T) - number of healthy individuals;
- DSR(I,T) - incidence of disease;
- DHD(I,T) - number of patients who have recovered;
- DR(I,T) - mortality;
- TMOY - discrete time step in the population part of the model;
- TRHH(I,I+1,T) - number of healthy individuals transferred from stratum I to stratum I+1;
- LD(I,J,T) - number of latent sick individuals;
- TRHL(I,J=A,T) - number of people in the initial stage of the disease;
- TRLI(I,J,T) - additional number of sick individuals from the group of latent sick, transferring from other strata;
- REAP(I,J,T) - number of latent sick individuals transferring to the group of individuals revealed as being ill, i.e. consuming HCS resources;
- TRLO(I,J,T) - number of latent sick individuals having transferred into other strata in the group of latent sick individuals;

- RP (I,J,T) - number of revealed sick individuals, i.e. consuming HCS resources;
- TRRI (I,J,T) - additional number of individuals from the group of revealed sick, having transferred from other strata;
- TRPO (I,J,T) - number of revealed sick individuals having transferred to other strata within the group of revealed sick individuals;
- HPS (T) - general number of individuals subject to screening examination;
- LDS (T) - general number of latent sick individuals;
- CDL (T) - "concentration" of latent sick individuals;
- AT (I,J,T) - number of latent sick individuals who request medical assistance on their own;
- AA (I,J,T) - number of sick individuals who have requested medical assistance;
- SD (I,J,T) - number of patients revealed by screening;
- GPS (T) - general productivity of screening resources;
- SDH (T) - physician-manpower resources of screening activities;
- TDH (T) - physician-manpower resources of treatment activities;
- KPS (J,T) - general number of revealed sick individuals
- TDHT (J,T) - physician-manpower resources corresponding to stage J;
- ADR (J,T) - general physician work load (as standard number of patients) of physician-manpower resources, involved in treatment activities;
- REA (J,T) - unutilized work load of physician-manpower resources;
- AAS (J,T) - number of latent sick individuals who have requested medical assistance;
- REAP (J,T) - number of latent sick individuals having transferred into the category of revealed patients;
- GDH (T) - general physician-manpower resources.

APPENDIX 2

- (1) $HP(I, TM) = HP(I, T) + DHD(I, T)$
 $- \{HP(I, T) * DSR(I, T) + HP(I, T) * DR(I, T)\}$
 $* TMOY - TRHH(I, I+1, T) + TRHH(I-1, I, T)$
- (2) $LD(I, J, T+1) = LD(I, J, T) + TRHL(I, J, T) + TRLI(I, J, T)$
 $- LD(I, J, T) * DR(I, T) * TMOY - REAP(I, J, T)$
 $- TRLO(I, J, T)$
- (3) $RP(I, J, T+1) = RP(I, J, T) + REAP(I, J, T) + TRRI(I, J, T)$
 $- RP(I, J, T) * DR(I, T) * TMOY - DHD(I, J, T)$
 $- TRRO(I, J, T)$
- (4) $HPS(T) = \sum HP(I, T)$
- (5) $LDS(T) = \sum LD(I, J, T)$
- (6) $CDL(T) = LDS(T) / \{LDS(T) + HPS(T)\}$
- (7) $AT(I, J, T) = ATP(I, J) * LD(I, J, T)$
- (8) $AA(I, J, T) = AT(I, J, T) + SD(I, J, T)$
- (9) $SD(I, J, T) = GRS(T) * CDL(T) * TMOY * ASD(I, J)$
- (10) $GPS(T) = SNOR(T) * ARS(T) + SNOD(T) * SDH(T)$
- (11) $SDH(T) = GDH(T) * TSPS(T)$
- (12) $TDH(T) = GDH(T) * TSPT(T)$
- (13) $RPS(J, T) = \sum RP(I, J, T)$

$$(14) \quad \text{TDHT}(J,T) = \text{TDH}(T) * \text{ATDH}(J,T)$$

$$(15) \quad \text{ADR}(J,T) = \text{TDHT}(J,T) / \text{DLN}(J,T)$$

$$(16) \quad \text{REA}(J,T) = \text{ADR}(J,T) - \text{RPS}(J,T)$$

$$(17) \quad \text{AAS}(J,T) = \sum \text{AA}(I,J,T)$$

$$(18) \quad \text{REAP}(J,T+1) = \begin{cases} \text{AAS}(J,T); & \text{REA}(J,T) \geq \text{AAS}(J,T), \text{ REA}(J,T) > 0 \\ \text{REA}(J,T); & \text{REA}(J,T) \leq \text{AAS}(J,T), \text{ REA}(J,T) > 0 \\ 0; & \text{REA}(J,T) \leq 0 \end{cases}$$

$$(19) \quad \text{GDH}(T) = \text{DOC}(T) * \text{TSD}(T) * \text{TMOH}$$

$$(20) \quad \text{RETR}(T) = \text{DELAY2}(\text{XRS}, \text{DES})$$

$$(21) \quad \text{ARS}(T) = \text{DELAY2}(\text{YRS}, \text{DSR})$$

REFERENCES

- [1] Venediktov, D.D., Systems Analysis of Health Services, in N.T.J. Bailey and M. Thompson, eds., Systems Aspects of Health Planning, North-Holland, Amsterdam, 1975.
- [2] Atsumi, K., and S. Kaihara, Planning National Medical Information Systems: A System Approach, in N.T.J. Bailey and M. Thompson, eds., Systems Aspects of Health Planning, North-Holland, Amsterdam, 1975.
- [3] Letourmy, A., Some Aspects of the Relationships Between Mortality, Environmental Conditions, and Medical Care, in N.T.J. Bailey and M. Thompson, eds., Systems Aspects of Health Planning, North-Holland, Amsterdam, 1975.
- [4] DeBoeck, G., User Oriented Modelling for Health Planning and Programming, paper presented at IIASA Conference on Systems Aspects of Health Planning, Baden, Austria, August 20-22, 1974.
- [5] Kiselev, A., A Systems Approach to Health Care, RM-75-31, International Institute for Applied Systems Analysis, Laxenburg, Austria, 1975.
- [6] Fleissner, P., An Integrated Model of the Austrian Health Care System, Austrian Academy of Sciences, Institute of Research for Socio-Economic Development, Vienna, 1974, Reprint.
- [7] Belanger, P., et al., On the Modelling of Large-scale Health Care Systems, Behavioral Science, 19, 1974.
- [8] Forrester, J.W., Principles of Systems: Text and Workbook, Wright-Allen, Cambridge, Mass., 1968.
- [9] Guetzkow, H., et al., Simulation in Social and Administrative Science, Prentice-Hall, Englewood Cliffs, N.J., 1972.
- [10] Cocrane, J.L., and M. Zeleny, eds., Multiple Criteria Decision Making, Univ. of South Carolina Press, 1973.
- [11] Klementiev, A.A., A Computer Method for Projecting a Population's Sex-Age Structure, RM-76-36, International Institute for Applied Systems Analysis, Laxenburg, Austria, 1976.