



Impact of Environmental Constraints in the Steel Industry

Ito, K.

**IIASA Research Memorandum
December 1975**



Ito, K. (1975) Impact of Environmental Constraints in the Steel Industry. IIASA Research Memorandum.
Copyright © December 1975 by the author(s). <http://pure.iiasa.ac.at/441/> All rights reserved. Permission to make digital or hard copies of all or part of this work for personal or classroom use is granted without fee provided that copies are not made or distributed for profit or commercial advantage. All copies must bear this notice and the full citation on the first page. For other purposes, to republish, to post on servers or to redistribute to lists, permission must be sought by contacting repository@iiasa.ac.at

IMPACT OF ENVIRONMENTAL CONSTRAINTS
IN THE STEEL INDUSTRY

K. Ito

December 1975

Research Memoranda are informal publications relating to ongoing or projected areas of research at IIASA. The views expressed are those of the author, and do not necessarily reflect those of IIASA.



Abstract

Based on Japanese data, the environmental management problem in the iron and steel industry has been investigated from various points of view. Some qualitative characteristics of the pollution problems in this industry are overviewed and classified by comparing them with pollution problems in other industries. To make the quantitative investigation of pollution phenomena in the iron and steel industry, a model plant is introduced with modern pollution control devices. To prevent the shortage of natural resources and to soften the environmental constraints in the future, the need for recycling systems for the wasted iron and steel is emphasized from the total system's point of view.



1. Introduction

As a result of the recent spreading of industrial development, human beings all over the world are facing a huge problem in environmental pollution. This problem is now urgent world-wide and recent events, particularly in Japan, have been dramatic. For Japan, the urgency seems caused fundamentally both by Japan's rapid industrial development and by the limited availability of Japan's land resources.

An example of this rapid industrial development can be found in the iron and steel industry which, has increased production at high rates as shown in Table 1.¹ As a result of rapid

Table 1. Development of pig iron and ordinary rolled steel products in Japan
($\cdot 10^3$ ton/year).

Year	Pig Iron		Crude Steel	Ferro-Alloys	Ordinary Rolled Steel Products		
	Production	Imports	Production	Production	Production	Imports	Exports
1950	2,233	1	4,839	66	3,486	-	-
1960	11,896	1,001	22,138	445	15,675	168	1,995
1965	27,502	2,631	41,161	658	30,034	16	8,226
1967	40,095	6,486	62,154	945	44,466	99	7,908
1968	46,397	4,498	66,893	1,066	48,594	11	11,644
1969	58,147	3,623	82,166	1,297	58,277	21	13,621
1970	68,048	2,896	93,322	1,665	66,691	28	15,225

Source: Ministry of International Trade and Industry.

development (in spite of depending heavily on imports of iron and ore and scrap from distant countries as shown in Table 2), Japan became the third largest producer of crude steel in the world by 1970 as shown in Figure 1. This is an index of Japan's successful industrial development, and this successful development is owing to the high concentration of production activity within limited areas.

¹See "Statistical Handbook of Japan, 1972," Bureau of Statistics, Office of the Prime Minister, Japan Statistical Association (1972), p. 51, 1972.

Table 2. Iron ore sources in Japan
($\cdot 10^3$ ton/year).

Year	Pro- duction	Imports						
		Total	West- Malaysia	Philip- pines	India	Australia	US	Canada
1950	826	1,435	521	575	96	-	0	0
1960	1,290	15,036	5,354	1,215	4,501	100	825	1,084
1965	1,119	39,018	6,956	1,482	7,913	231	2,660	1,950
1967	1,087	56,695	5,192	1,453	10,829	8,314	3,608	1,680
1968	1,059	68,164	5,116	1,536	12,772	13,814	3,545	1,977
1969	955	83,247	5,352	1,614	13,633	23,235	3,153	2,044
1970	861	102,090	4,906	1,872	16,522	36,597	3,257	2,301

Source: Ministry of International Trade and Industry.

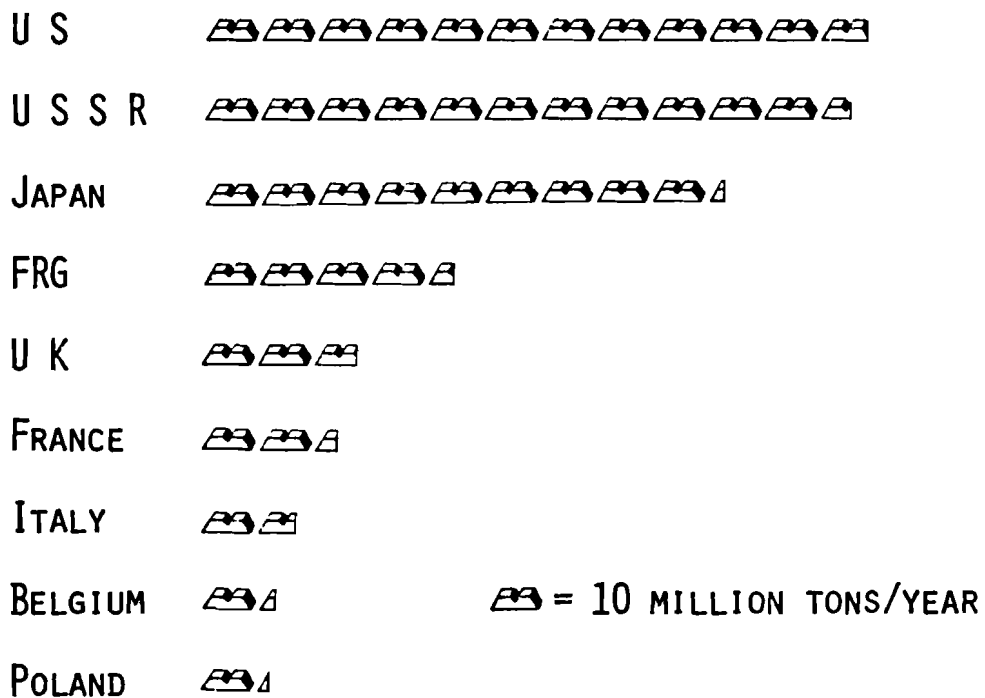

Figure 1. Production of crude steel
by country in 1970.

In the light of both the rapid development and the concentrated industrial activity, it is therefore not really surprising that the Japanese government suddenly passed fourteen laws dealing with pollution and the environment in 1970 to protect the land from pollution. These laws soon affected industry: after the completion of construction for Kobe Steel's Kakogawa No. 2 blast furnace, operation had to be delayed until the pollution control questions had been settled with the civil authorities.² It must be said, however, that modern iron and steel making plants are, generally speaking, well constructed large systems operated by highly computerized control devices. In contrast, pollution control systems are still not very well constructed, and therefore environmental pollution is not very well controlled. The fundamental reasons for this are involved with pollution control investment:

- 1) production costs will increase owing to pollution control in order to pay for both the development of the technology and the devices themselves;
- 2) pollution control technology is behind in its development owing to its costs (for example, the exhaust gas desulphurization technique is still not established and is still under research); and from this further there is a lack of technology to recycle and to utilize waste material.

Clearly, as environmental quality control laws become more stringent it will become increasingly necessary to take them into account beforehand; the impact of environmental constraints on industry will become more pronounced in the future.

In this paper, several aspects of environmental pollution from the iron and steel industry will be examined with a view to the following:

- a) clarification of pollution problem characteristics in the iron and steel industry by comparing them with those of other industries;
- b) classification of environmental pollution in the iron and steel industry more in detail;
- c) survey of a model plant which has adopted modern pollution control devices;
- d) construction of a fundamental framework as a basis from which to investigate the total management of environmental pollution in the iron and steel industry in the future.

²I. Codd, "Pollution Control and the Iron and Steel Industry," Report of the Third Interregional Symposium on the Iron and Steel Industry organized by UNIDO (Brasilia, Brazil, Oct. 14-21, 1973), pp. 1-50.

2. Pollution Problem Characteristics in the Iron and Steel Industry

It is essential that we examine the industrial pollution and waste problems with a broad point of view; each industry is connected with many other industrial activities. For example, environmental constraints in the steel industry are affected by other industries. In this section, based on Japanese data, let us clarify briefly the characteristics of pollution problems in the iron and steel industry compared with other industries.

First of all, it is necessary to investigate the quality and quantity of inputs into each industry, for example, raw materials, energy, water resources, and so on: available input materials and energy roughly determine the characteristics of the pollution in each industry. As an example, let us consider one of the most important factors of air pollution, sulfur oxides.

The generation of SO_x depends on the quality of available fuel oil, coal, and iron ore. For example, Table 3 shows the amount of heavy oil used by Japanese industries in 1970. The average percentage of sulfur in class C heavy oil is 1.93%.³ This table shows that the quality of heavy oil used mostly by the iron and steel industry is at a relatively low level.

Table 3. Heavy oil consumption by industries in Japan in 1970 ($\cdot 10^3$ kl/year).

Industry	Heavy oil			
	Class A	Class B	Class C	Total
iron and steel	342	1,476	9,625	11,443
food	514	724	2,021	3,259
textile	148	533	3,997	4,678
pulp, paper	37	266	5,472	5,775
chemical	199	937	11,510	12,645
ceramic	242	1,394	8,710	10,346
non-ferrous metals	173	591	1,428	2,193
mining	31	99	269	399
electric power	-	-	35,621	35,621
etc.	538	1,494	2,584	4,616
total	2,224	7,514	81,237	90,975

³M. Furusawa, "An Overview of Technology for Environmental Pollution Control, No. 1" Kogai-boshi-sangyo (Environmental Pollution Control), 3, 1 (1973), 2-13 (in Japanese).

Next, the consumption of coal by each industry in Japan (1970) is shown in Table 4.⁴ This table shows that 63% of the coal used was consumed by the iron and steel industry. Because of this great amount of fuel consumption together with raw materials, the iron and steel industry generates huge amounts of SO_x which goes into the air as shown in Table 5 (see Furusawa cited above).

Now let us turn briefly to consider water pollution problems. Fresh water is recycled relatively well in the iron and steel industry. However, as shown in Table 6, the amount used is very high.⁵ In addition to fresh water, sea water is needed in amounts two to three times greater. As a result of this water consumption, it is necessary to treat large amounts of waste water.

Next, let us briefly discuss the solid waste problem in the iron and steel industry. Table 7 shows the total amount of solid wastes exhausted by each industry in Japan.⁶ Though the solid wastes generated in the iron and steel industry are of great quantities, they are relatively well reused by other industries; for example, blast furnace slag is reused as shown in Table 8 (see Hisada, 1972).

Lastly, let us consider the problem of pollution control investment. Figure 2 shows that the pollution control investment by large-scale industries in Japan, of late, is about 10% of their total investment, and this appears quite high even when compared to the US level.⁷ In the past, this type of investment has been very low, especially for the iron and steel, petrochemical, pulp and paper, and other industries which are large consumers of environmental resources.

Figure 3 shows some results of the impact of the price of pollution control on various finished manufactured goods, assuming that in the future a fixed rate of pollution prevention cost per sale is passed on in the form of a price increase. As we can see,

⁴K. Hisada, "The Role of Chemistry in Steel Industry," Kagaku-kogyo (Chemical Industry), 23, 11 (1972), 33-40 (in Japanese).

⁵A. Sugiki, "Water Pollution--Phenomenon and Control," Giho-do (1974) (in Japanese).

⁶D. Iwasaki, "On Treatment of Sludge by Incineration," Gijutsu-to-kogai (Techniques and Pollution), 2, 10 (1972), 38-46 (in Japanese).

⁷"Quality of the Environment in Japan, 1973," Environment Agency of Japan (1974).

all industries which heavily pollute the air (chiefly the iron and steel, cement, gas and electricity industries) or water (chiefly the processed food, synthetic fiber, pulp and paper, and chemical industries) will have high rates of investment in pollution prevention, leading eventually to a high rate of price increase (see "Quality of the Environment in Japan, 1973"). However, price investigations of this type are still under way, and much more effort must be focused in this direction.

Table 4. Consumption of coal by industry in Japan in 1970 ($\cdot 10^3$ ton/year).

Industry	Coal
iron and steel	55,472
electric	18,826
briquette	2,545
gas	2,339
coke	2,233
fuel for railway	672
ceramic	628
chemical fertilizer	282
general fuel use	2,413
etc.	2,962
total	88,372

Table 5. Emission of SO_x by industry in Japan in 1970 ($\cdot 10^3$ ton/year)

Industry	Exhaust amount of SO_x	Percentage
electric power	1,764	29.5
iron and steel	1,604	26.8
chemical	766	12.8
ceramic	512	8.6
pulp, paper	352	5.9
etc.	882	16.4
total	5,880	100

Table 6. Consumption of fresh water by industry in Japan in 1969.

Industry	Production ($\cdot 10^8$ yen/year)	Unit of water consumption (m^3 /day)/($\cdot 10^8$ yen/year)	Amount of fresh water ($\cdot 10^3 m^3$ /day)	Recycling ratio (%)
iron & steel	5,190	294.53	1,528.6	70
food	6,217	71.83	446.6	15
textile	3,864	143.50	554.5	5
clothing	841	8.67	7.3	0
lumber & wood products	1,969	14.07	27.7	10
furniture & fixtures	874	10.86	9.5	6
pulp, paper & allied pro- ducts	1,864	791.64	1,475.6	25
printing & publishing	1,757	14.50	25.5	40
various chem- ical industries	4,836	543.34	2,622.8	60
refining of coal & oil	1,490	157.17	234.2	70
rubber products	703	102.15	71.8	40
leather & leather products	300	32.79	9.8	0
ceramics	2,121	146.17	310.0	40
nonferrous metals	2,574	101.86	262.2	50
metal products	3,062	28.16	86.2	5
mechanical industry	5,285	16.46	87.0	15
electrical machinery	6,103	19.77	120.7	20
transport equipment	6,300	33.63	211.9	55
precision industry	746	16.21	12.1	5
etc.	2,078	50.67	105.3	0
total	58,175	153.42	8,209.3	45

Table 7. Solid wastes exhausted by industry in Japan in 1970 ($\cdot 10^4$ ton/year).

Industry	Exhausted solid wastes	Percentage
iron & steel	2,006	34
pulp, paper & allied products	354	6
chemical	944	16
nonferrous metals	767	13
electrical machinery	885	15
etc.	944	16
total	5,900	100

Table 8. Reuse of blast furnace slag in Japan in 1971 ($\cdot 10^3$ ton/year).

road	9,573
roadbed	272
concrete	1,782
fertilizer	413
rock wood	103
cement	1,587
building material	204
blast sand	31
landfill	5,591
self consumption	4,531
total	24,089

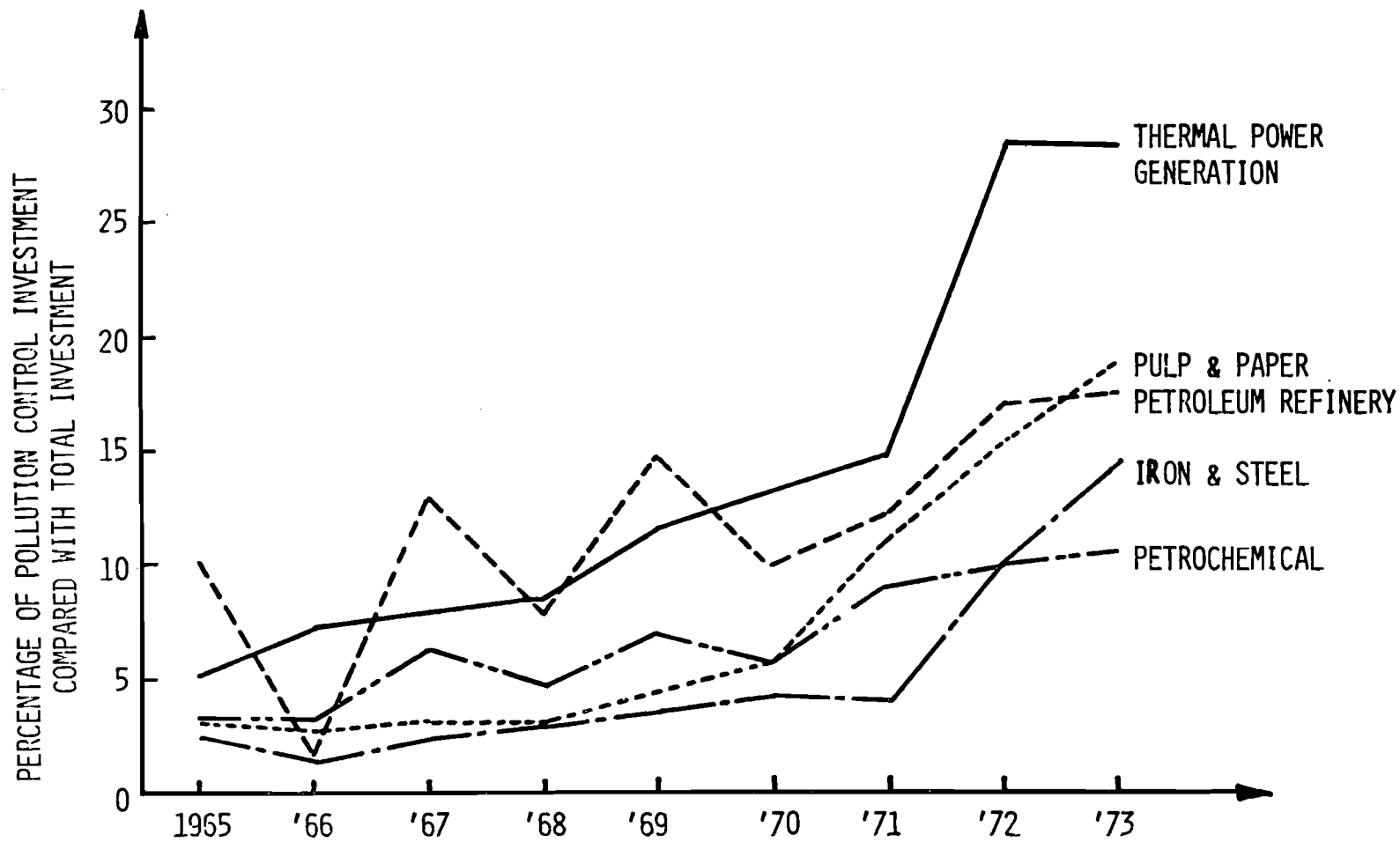
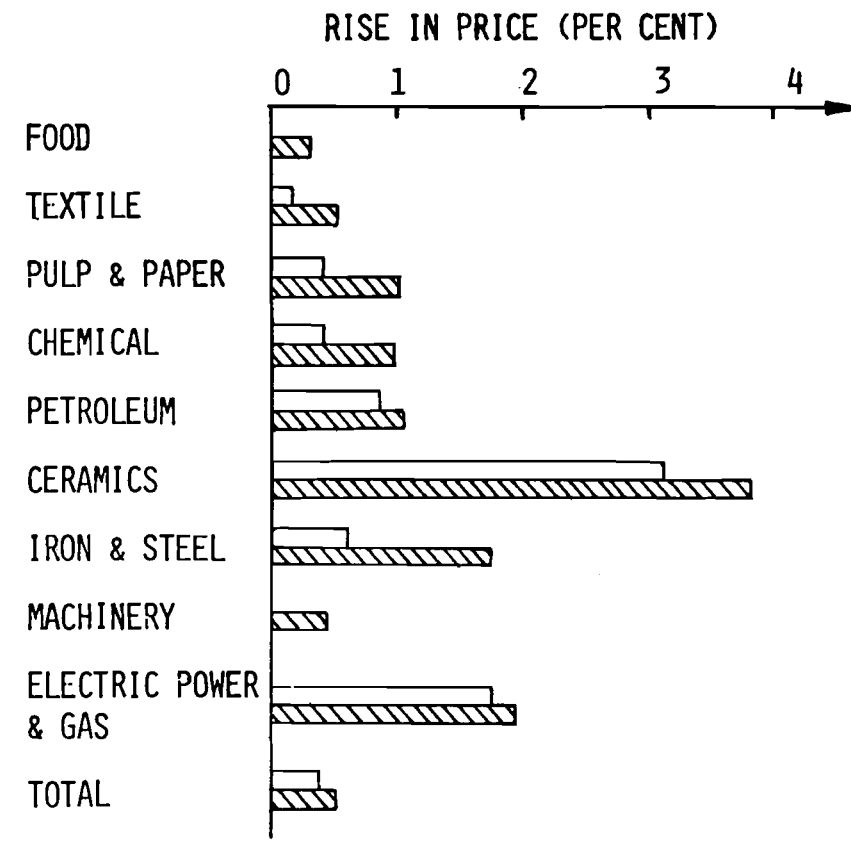
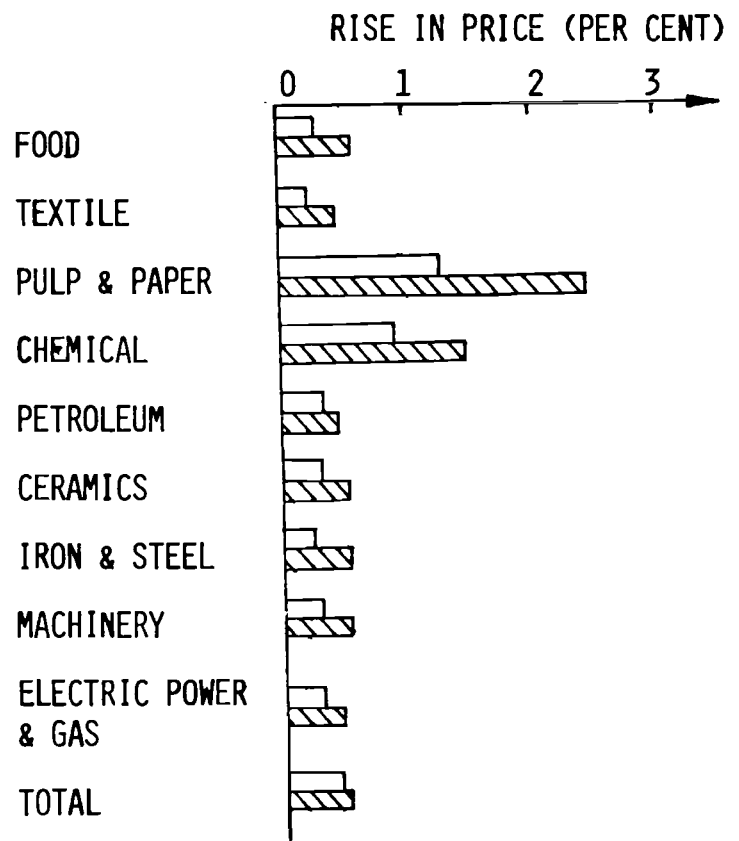

Figure 2. Pollution control investment of large enterprises in Japan.



(A) WATER POLLUTION

(B) AIR POLLUTION

— : DIRECT RISE IN PRICE BY INCREASE OF COST

▨ : RISE IN PRICE BY DIRECT AND INDUCED EFFECTS ON COST

Note: Induced effects on cost are estimated using I-O analysis.

Figure 3. Effects of pollution control on prices.

3. Classification of Environmental Pollution in the Iron and Steel Industry

In the previous section, it was stated roughly that the iron and steel industry consumes large amounts of raw materials, energy, and water and exhausts air and water pollutants and solid wastes into the environment. In this section, let us classify the environmental pollution in the iron and steel industry in more detail. Much research has been done on the classification of pollutants and solid wastes in the iron and steel industry from various aspects.⁸ Recently, for example, an international symposium was held on environmental control in the steel industry in Tokyo.⁹

Because an iron and steel making plant is a large, complex system, its pollution phenomena are full of variety; the plant causes air, water, soil and thermal pollution, solid wastes, noise, vibration, and odor. Clearly, it is not an easy task to classify in perfect detail the pollution phenomena in the iron and steel industry; however, the important items of pollutants are discussed below.

Important air pollutants include the particulates SO_x , NO_x , CO, HC; for water pollution, such items as phenols, CN, spent acid (hydrochloric acid, chromic acid), water with wasted oil, suspended solids (SS) and contaminated rinse water must be considered. For solid wastes, slag is the most important material; for odor, hydrogen sulfide must be taken into account. In Codd (1973), Bond and Straub (1972), and Russell and Vaughn (1974)¹⁰ detailed investigations have been carried out for the classification of pollutants and their generation sources.

Pollution phenomena are shown together with a simplified material flow in an iron and steel making plant in Figure 4. In this flow diagram, pollution phenomena such as soil pollution, noise, vibration, and odor are omitted. Pollution problems owing to power generation plants and other incidental plants are also omitted; the secondary and tertiary pollutions are also omitted. Note that in Figure 4 we have a typical example of secondary pollution in water pollution because air pollution is controlled by a wet scrubber.

⁸ See Codd (1973) cited above. See "Environmental, Health, and Human Ecologic Considerations in Economic Development Projects", World Bank (1974), pp. 111-113; Air Pollution, vol. 1 of CRC Handbook of Environmental Control, ed. R.G. Bond and C.P. Straub (Cleveland, Ohio, CRC Press, 1972).

⁹ "Report on the Symposium on Environmental Control in the Steel Industry", Feb. 18-21, 1974, (Tokyo, International Iron and Steel Institute).

¹⁰ C.S. Russell and W.J. Vaughn, "A Linear Programming Model of Residuals Management for Integrated Iron and Steel Production," J. Environmental Economics and Management, 1, 1 (1974), 17-42.

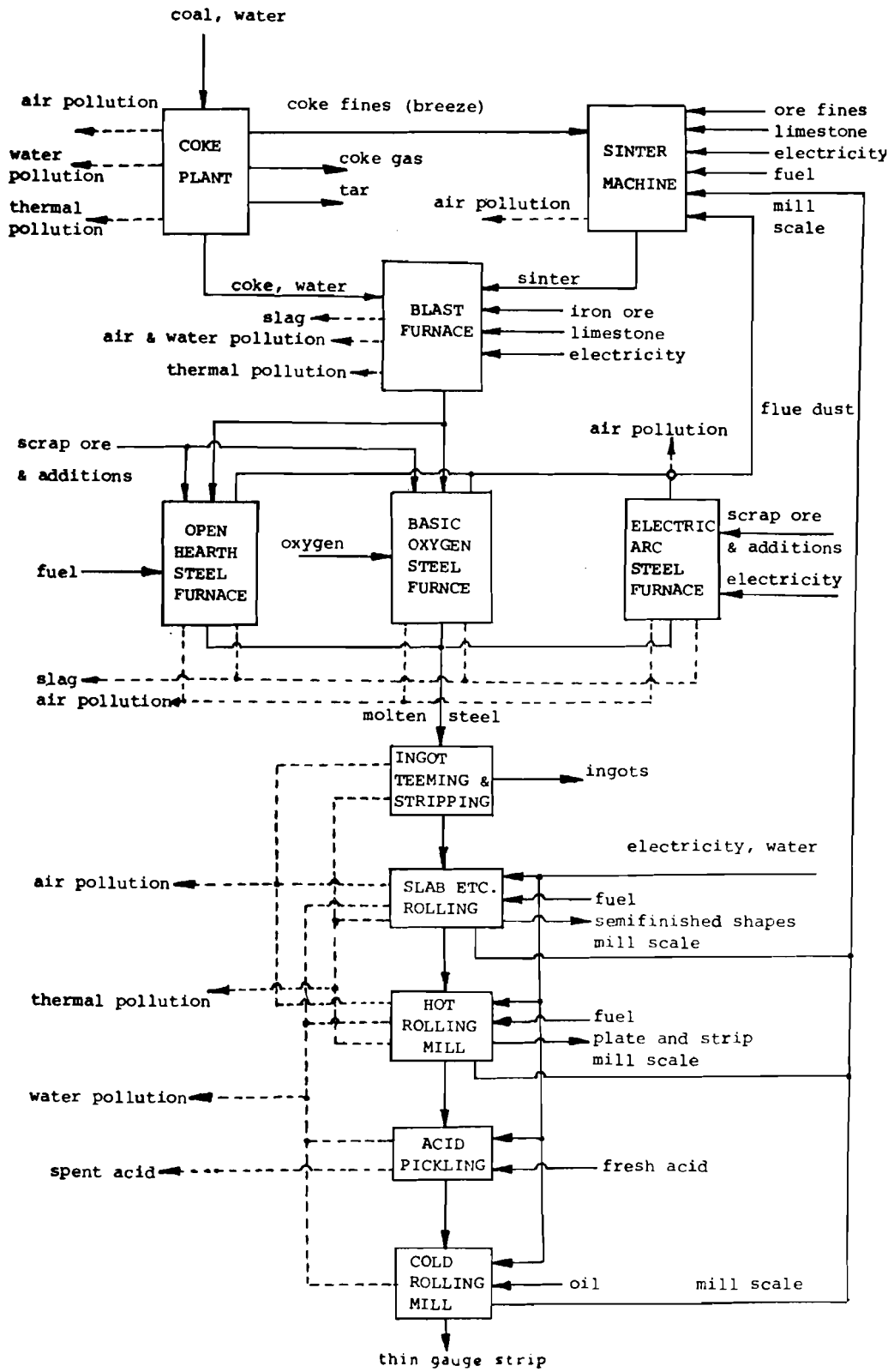

Figure 4. A simplified material flow and pollution phenomena in an iron and steel making plant.

The next step of the investigation is to build a flow diagram in which the amount of generated pollutants is shown for each process in the steel making plant. We shall return to this problem in the following section.

4. Survey of a Model Plant which Has Adopted Modern Pollution Control Devices

In the previous section, no quantitative investigation of pollution in the iron and steel industry was shown. The quantitative input-output relationship of a plant depends on the size of the plant, type of production, level of technology, quality of input materials, and so on. Furthermore, since the recent development of pollution control technology has been very rapid, it is a difficult task to evaluate the pollution control effects.

It is important, however, to plan a model plant in which modern pollution control devices are adopted. Recently, a few studies have been done in this direction,¹¹ and in this section we will briefly survey a model plant investigated by J. Nakagawa.

First of all, it is necessary to trace the input-output relationship of the whole plant. For a model plant that produces six million tons of steel per year, the rough material flow is estimated in Figure 5. It is also estimated that heavy oil energy inputs of 89.6 kl/h and electric power inputs of $2,250 \cdot 10^6 \text{ kwh/year}$ (= 375 kwh/ton of steel iron) are necessary; further, fresh water inputs of $73 \cdot 10^6 \text{ ton/year}$ (= $200 \cdot 10^3 \text{ ton/day}$) are necessary for the industrial water for this model plant. (No cooling water is included in this figure.)

Figure 6 shows an illustrative picture of the plant in which air and water pollution control devices are adopted for each process. In this kind of research, only particulates and sulfur oxides of air pollutants and some items of water pollution are investigated; pollution control effects are also taken into account. The results that were obtained here are summarized in Tables 9 and 10. In this research, secondary pollution from air pollution control by a wet scrubber is taken into account. As a result, the estimate for the construction investment of pollution control equipment is 10.9% of the total construction investment of the model plant.

¹¹ See Codd (1973) and J. Nakagawa, "Quantitative Analysis of Pollutants in Iron and Steel Industry," Kogai-kenkyu (J. Environmental Pollution), 1 (1972), 38-50 (in Japanese).

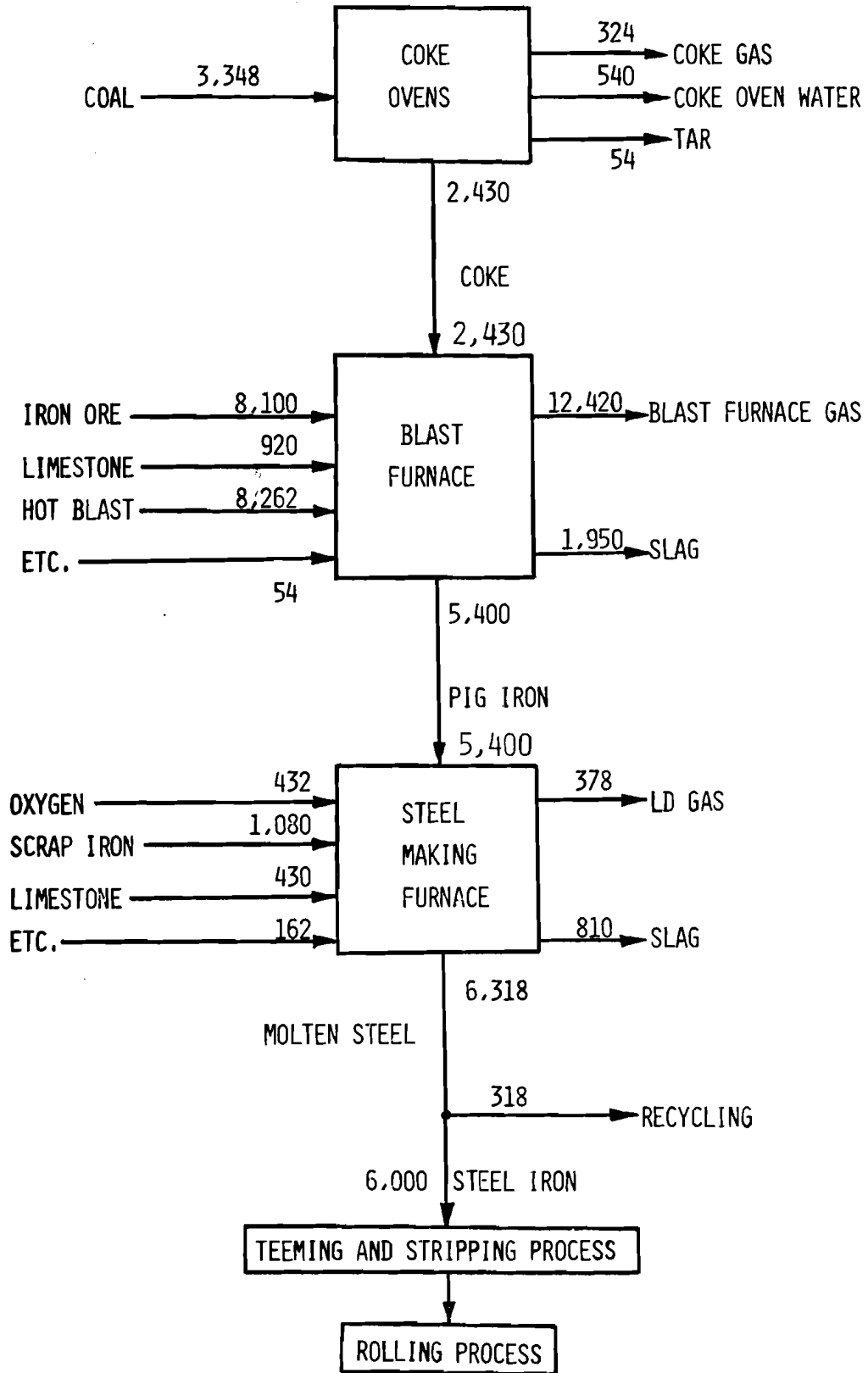

Figure 5. Material flow diagram of a model plant ($\cdot 10^3$ ton/year).

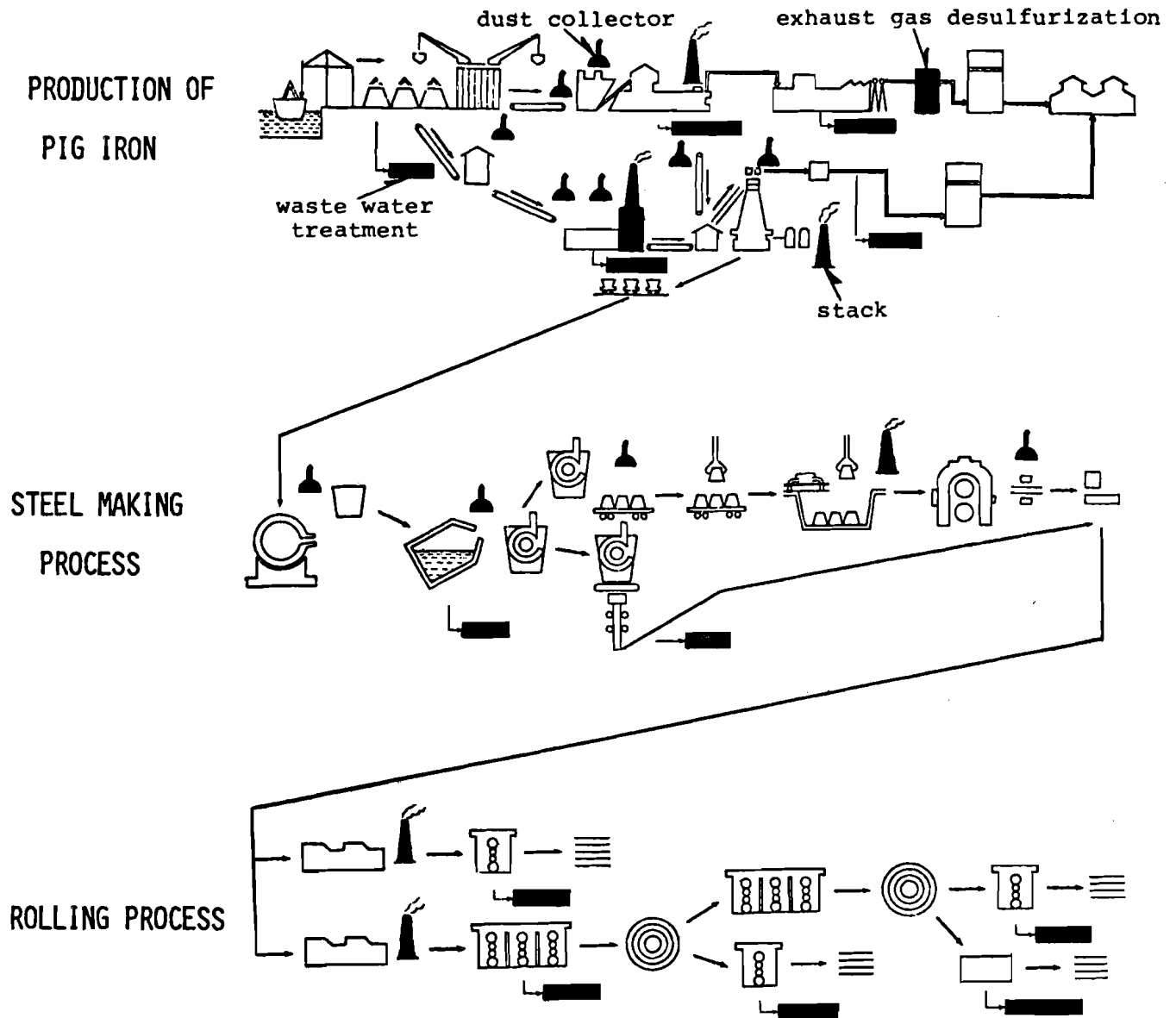

Figure 6. Air and water pollution control equipment in an iron and steel making plant.

5. Total Management of Environmental Pollution in the Steel Industry

In the previous sections, the complexity of the pollution problem in the iron and steel industry was reviewed from various aspects. In this section, let us summarize the environmental management problems in the iron and steel industry from the total system's point of view.

Table 9. Air pollution and its control in an iron and steel making model plant.

Process	Pollutant	Exhausted gas volume (Nm ³ /year)	Pollutant's concentration (gr/Nm ³)		Pollutant's amount (ton/year)*		Pollution control investment (• 10 ⁶ yen)
			input	output	input	output	
iron ore plant	particulate	30,500	5	0.1	76,146	1,523	1,050
coke ovens	particulate	22,200	10-30	0.1-1.0	55,722	571	656
	SO _x	2,000	19	0.35	19,977	368	1,500
sintering	particulate	55,700	1.5-15	0.1	172,744	2,718	1,950
	SO _x	35,600	250(ppm)	25(ppm)	3,104	590	8,000
pig iron	particulate	68,000	0.2-5	0.1-0.1	91,135	1,827	1,460
steel making	particulate	30,000	5-80	0.1	160,874	449	3,150
teeming & pouring	particulate	8,500	5	0.05	10,610	106	270
total	particulate	214,900	0.2-80	1.01-1.0	567,231	7,194	8,536
	SO _x	37,600	19	0.35	23,081	958	9,500

*The amount of sulfur oxide is calculated by the weight of sulfur.

Table 10. Water pollution and its control in an iron and steel making plant.

	Amount of waste water (ton/day)	SS				Waste oil				etc.			
		(ppm)		(ton/year)		(ppm)		(ton/year)		(ppm)		(ton/year)	
		input	output	input	output	input	output	input	output	input	output	input	output
iron ore plant	14,250	7,500-8,500	40	41,610	208								
blast furnace	63,130	1,000-4,000	40	57,606	922								
direct waste water Coke ovens	1,200	100	40	44	18	50-	0-	55	2	CN:100-150, phenol:1,500-2,000	CN:1 phenol:1	CN:55 phenol:767	CN:0.4 phenol:0.4
						200	10						
wet scrubber	16,150	7,500-8,500	40	55,918	280								
pickling coating	36,000	30-600	40	4,145	464	500	0-10	5,475	55	HCl:100-1,000, CrO ₃ :5,000-10,000	HCl:0 CrO ₃ :2	HCl:8,432 CrO ₃ :16,426	CrO ₃ :4
direct cooling water Teeming and stripping	30,000	300	40	3,285	438								
wet scrubber	3,670	7,500-8,500	40	10,716	54								
etc.	16,740	2,500-3,500	40	18,330	244								
total	184,140	2,500-3,500	40	201,633	2,688			5,530	57			CN:55 phenol:767, CrO ₃ :16,426, HCl:8,432	CN:0.4 phenol:0.4 CrO ₃ :4

The environmental management and control problems that must be taken into account at each level of the industry are planning, scheduling, and operations. Particularly, special emphasis must be placed at the planning level. Here, the location and the scale of the plant must be checked not only from the standpoints of available raw materials, energy, water, and transportation problems, but also from local environmental conditions. Because nature has the ability of self-purification, we must control the exhausted amounts of pollutants to keep within the upper limit of nature's environmental self-purification capacity. Nature's self-purification ability depends on many factors such as meteorological change by day and by season. Until now, no exact standard defining the capacity of nature's self-purification has been found.

As a basis for the consideration of environmental management for the iron and steel industry, we must build a mathematical model which clarifies the input-output relationship of the whole plant. The model would include the relationships between raw materials, energy, water, production, pollutants, waste materials, and so on. Generally, these relationships depend on the level of production technology, and qualities of raw materials and energy. Based on this model, we must determine the pollution control policy at each process. This means determining the best pollution control devices and their capacities together with the pollution control investment. As an example, the distribution of the particulate size differs for each process, and thus it is necessary to determine the best pollution control devices taking the characteristics of the pollutant into account. Furthermore, we must investigate the problem of loss of efficiency owing to pollution control devices (for example, pressure loss caused by air pollution control equipment), necessary amounts of energy (and water) to drive the devices, and the costs involved. At the same time, it is necessary to consider secondary and tertiary aspects of pollution management.

Finally, computer control is necessary to operate all processes under optimal conditions. For example, incompletely burned fuel causes high costs and it generates pollution; it can be prevented by computer controlled adjustment devices. Also production processes and pollution control devices slowly change their characteristics as they age, and it becomes necessary to repair the devices or otherwise change operating conditions to maintain the best possible operating conditions in the plant. Clearly, the pollution control investment increases the price of production, and the economic aspects of the pollution control management must be taken into account on the long range planning level.

6. Conclusions

In this paper, based on Japanese data, the pollution problem in the iron and steel industry has been investigated from various points of view. Together with the effort to develop individual

pollution control technologies, it appears necessary to approach this problem through the application of modern systems science techniques because of the complexities involved. Furthermore, in addition to the management of the environmental pollution problem within the iron and steel making plant, we need to build recycling systems for waste iron and steel to prevent a shortage of natural resources. In Figure 7, the amount of waste iron and steel recycled in Japan is shown;¹² we can see here that a considerable percentage of waste iron and steel is consumed as raw material in the steel industry once again. However, if we misuse industrial production we will face not only a shortage of natural resources, but many stronger environmental constraints in the future.

¹²G. Jinpo, "Can we Harmonize Industrial Activities with the Environment?" Nikkan-kogyo-shinbunsha (1973), 130 (in Japanese).

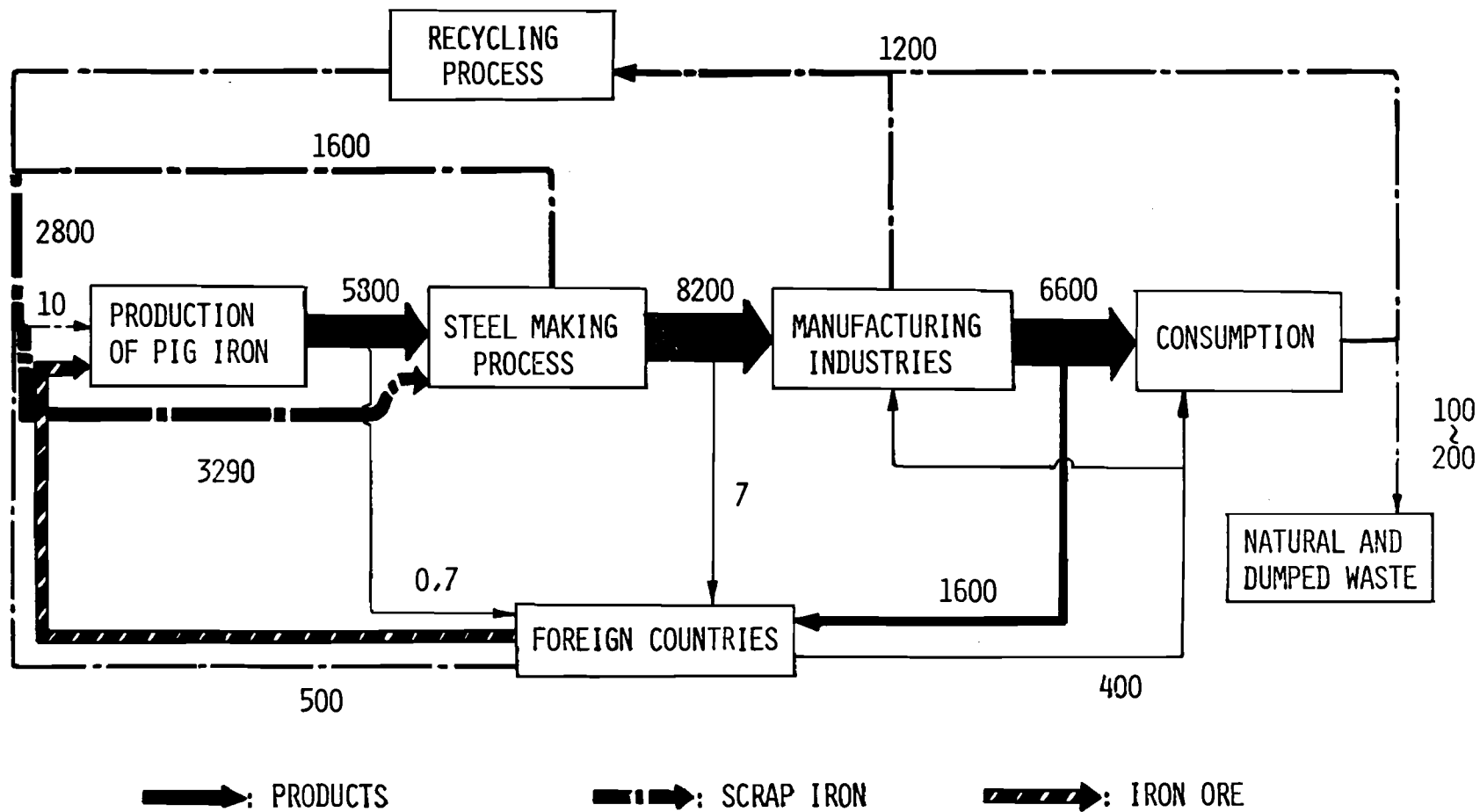

Figure 7. Recycling system of iron and steel making: Japan, 1969 ($\cdot 10^4$ ton/year).