

# Considerations on the Large Scale Deployment of Nuclear Fuel Cycles

**Avenhaus, R., Häfele, W. and McGrath, P.E.**

**IIASA Research Report  
October 1975**



Avenhaus, R., Häfele, W. and McGrath, P.E. (1975) Considerations on the Large Scale Deployment of Nuclear Fuel Cycles. IIASA Research Report. Copyright © October 1975 by the author(s). <http://pure.iiasa.ac.at/224/> All rights reserved. Permission to make digital or hard copies of all or part of this work for personal or classroom use is granted without fee provided that copies are not made or distributed for profit or commercial advantage. All copies must bear this notice and the full citation on the first page. For other purposes, to republish, to post on servers or to redistribute to lists, permission must be sought by contacting [repository@iiasa.ac.at](mailto:repository@iiasa.ac.at)

CONSIDERATIONS ON THE LARGE SCALE  
DEPLOYMENT OF THE NUCLEAR FUEL CYCLE

R. Avenhaus, W. Häfele and P.E. McGrath

Veritas est adequatio intellectus ad rem/year  
(Tommaso d'Aquino/Cesare Marchetti)

October 1975

Research Reports are publications reporting on the work of the authors. Any views or conclusions are those of the authors, and do not necessarily reflect those of IIASA.



## List of Contents

1. Introduction
2. Description of Supporting Fuel Cycle
3. Radiation Doses
  - 3.1 Introduction
  - 3.2 Point Sources
  - 3.3 Volume Sources
  - 3.4 Population Densities and Doses
  - 3.5 Number of Facilities
4. Normal Operations Releases
  - 4.1 Introduction
  - 4.2 FBR Reactor Fuel Cycle
  - 4.3 HTGR Reactor Fuel Cycle
5. Accidental Releases
  - 5.1 Introduction
  - 5.2 Reactor Accidents
  - 5.3 Reprocessing Facility Accidents
  - 5.4 Liquid Waste Storage Facility Accident
  - 5.5 Waste Solidification Facility Accident
  - 5.6 Transportation Accidents
6. Final Waste Storage Facility Accident
7. Theft of Fissile Material and Destruction of Nuclear Facilities
  - 7.1 Classification
  - 7.2 Theft of Fissile or Radioactive Material by a Private Group: Diversion Strategies
  - 7.3 Release of Radioactive Material
  - 7.4 Destruction of a Nuclear Facility
  - 7.5 Construction of a Nuclear Explosive Device
8. Summary of Radiation Doses
9. Policy Considerations and the Concept of Utility
  - 9.1 Reactor Accidents
  - 9.2 A Decision Procedure for the Deployment of a Large Nuclear Fuel Cycle
- Appendix 1: Maximum Permissible Concentrations of Radionuclides, as Recommended by the ICRP
- Appendix 2: Radionuclide Transport in Air and Water



## Abstract

In recent papers by Häfele, Manne and Schikorr, strategies for a transition from fossil to nuclear fuels are considered for a model society of 250 million people with an asymptotic energy consumption of 10 kilowatt thermal per capita. In the final state, a purely nuclear energy production system, based on only two reactor types, was assumed to cover all electric and non-electrical energy demands of the model society.

It is the purpose of this paper to evaluate the whole nuclear fuel cycle belonging to the asymptotic nuclear energy production system. In order to achieve this, all normal operational and accidental risks connected with the nuclear material throughputs are analyzed. Thus, an idea of the relative importance of the different hazards is obtained; furthermore, the basis for a comparison of the nuclear option with alternative options (which is the subject of forthcoming work) is given. With this purpose in mind, only orders of magnitude are considered throughout the paper; in addition, the argumentation is restricted to the level of expected values.

The structure of this paper is as follows. Following the introduction, the mass flows of nuclear material through the nuclear fuel cycle are analyzed. The methodology used is then developed. The normal operations releases of radioactivity are considered, and possible modes of accidental radioactive releases are analyzed; the problem of a final waste storage is treated separately because of its unique nature. Different kinds of sabotage and blackmail, including the construction of a nuclear explosive device, are next analyzed, and finally all calculations are summarized. In conclusion, a number of decision-oriented assessments are identified that must be made when the large-scale deployment of nuclear energy is considered.

## Acknowledgement

In the course of the work on the paper, the authors had advice from many scientists in different fields. Without giving them any responsibility, the authors would like to thank especially Dr. F. Pittmann (US ERDA), Dr. W. Schikarski (GFK Karlsruhe) and Dr. E. Zebrowski (EPRI, Palo Alto) for comments concerning the whole paper.

Prof. E. Hübl (Hochschule für Bodenkultur, Vienna) and Prof. H. Kinzel (Pflanzenphysiologisches Institut, University of Vienna) for the provision of iodine data, and Dr. R. Keeney (IIASA, Laxenburg) for comments on the ninth chapter.





Considerations on the Large Scale  
Deployment of the Nuclear Fuel Cycle

R. Avenhaus, W. Häfele and P.E. McGrath\*

1. Introduction

In the last thirty years the extent to which a given primary energy source was used was determined primarily by economic reasons; the least expensive and most flexible energy source obtained the greatest market share. An example is the replacement of coal by oil in many parts of the world in the late 1950's. Only in the past two years, in view of the limitation of the world's fossil energy resources, has the secure supply of large amounts of energy for long time periods been considered of equal importance. Nuclear energy followed its own lines of development during this time: in the beginning, the emphasis was on innovation, and indeed, nuclear engineering has served as a vehicle for entering new domains of technological, managerial and regulatory sophistication (a most striking example in this connection is quality control). Only in the latter part of the sixties, and by concentrating on power station sizes beyond 600 MW, has nuclear energy become competitive. For the past few years the favorable reserve aspect of nuclear energy has strongly accelerated the development of this energy source.

While the short term aspect of the problem of secure supplies of large amounts of energy is definitely resource oriented, this will be most probably not the case in the long run (see Ref. [1-1]). Today four options appear to be available with virtually unlimited supplies of energy, as far as resources are concerned:

---

\*Institute for Applied Systems Analysis and Reactor Physics, Nuclear Research Center, Karlsruhe, Federal Republic of Germany.

- Nuclear power from fission,
- Nuclear power from fusion,
- Solar power,
- Geothermal power.

With these options it will be the systems implications of handling large amounts of energy that will evolve as constraints. This has been referred to as embedding the flow of such large amounts of energy through the ecosphere (i.e., the lithosphere, the hydrosphere, the atmosphere) and the sociosphere [1-2]. At present only the option of obtaining power from fission breeders is technically and industrially feasible. Assuming for a moment that all four options will turn out to be feasible, and further that all options will be equally economical (which is very doubtful), then it is the systems implications that will be the criteria for the choice of one of these options or perhaps the identification of an optimal mix.

In order to analyze their systems implications, it is necessary to describe these four options in their entirety. In the Energy Project of the International Institute for Applied Systems Analysis it was thought advisable to go to the extreme and to consider scenarios. In these scenarios it is assumed that for a certain society, all of the energy demands are met by any one of the four options mentioned. This work was initiated for the nuclear option by Häfele, Manne and Schikorr [1-3], [1-4]; the solar option is being studied by Weingart [1-5]. After the completion of the scenario work, comparisons will be made.

In the work of Häfele, Manne and Schikorr, strategies for a transition from fossil to nuclear fuels are considered for a model society of 250 million people with a primary energy consumption of 10 kW thermal per capita. They assumed 7.5 kW thermal were for non-electrical purposes with an annual growth rate of 4%, and 2.5 kW thermal for the production of electrical energy with an 8% annual growth rate. The initial average population growth rate of the model society was assumed to be 5%. With time the energy demand undergoes a transition: after 45 years the population has increased by 50% and then assumes a zero

growth rate, while the per capita consumption has doubled. The makeup of the energy consumption is 10 kW thermal per capita for electrical purposes and 10 kW for non-electrical purposes. The reactor configuration that produces the energy needed is based on the principle of breeding; otherwise resources would continue to be a limiting constraint [1-1], [1-2]. Whereas the main purpose of the work of Häfele, Manne and Schikorr was to identify strategies for the transition phase, we will concentrate in the following on the asymptotic state of the energy system. The reactor configuration of this asymptotic state is represented in Fig. 1.1. For the assumed 1:1 ratio of electrical to non-electrical energy, a combination of Fast Breeder Reactor (FBR) and High Temperature Gas Cooled Reactor (HTGR) seems to be an appropriate example for a reactor configuration. The FBR is designed to produce electricity while its breeding gain is used to meet the net fuel requirements of the HTGR, which in turn is used to produce non-electrical energy. For example, the HTGR would produce process heat for the production of hydrogen by water splitting.

It is the primary purpose of this paper to analyze the consequences for a society that decides to meet all its primary energy demands with nuclear energy. This implies the analysis of the mass flows in the nuclear fuel cycle that are necessary to maintain reactor operations, and of all possible operational and accidental releases of radionuclides from the nuclear facilities. It should be explicitly stated that the economics of nuclear power is not considered. Furthermore, the waste heat problem is not analyzed as it is common to all primary energy sources (to varying degrees) and therefore does not play a major role in the comparison of the different options mentioned earlier. Finally, the methodological approach taken in this paper should be clarified: as no reference is made to actual sites or weather conditions, a certain abstraction and stylization is necessary. Each actual case requires a much more detailed evaluation, which has been made for various single nuclear facilities (see, e.g., [1-6], [1-7], [1-8]). The idea

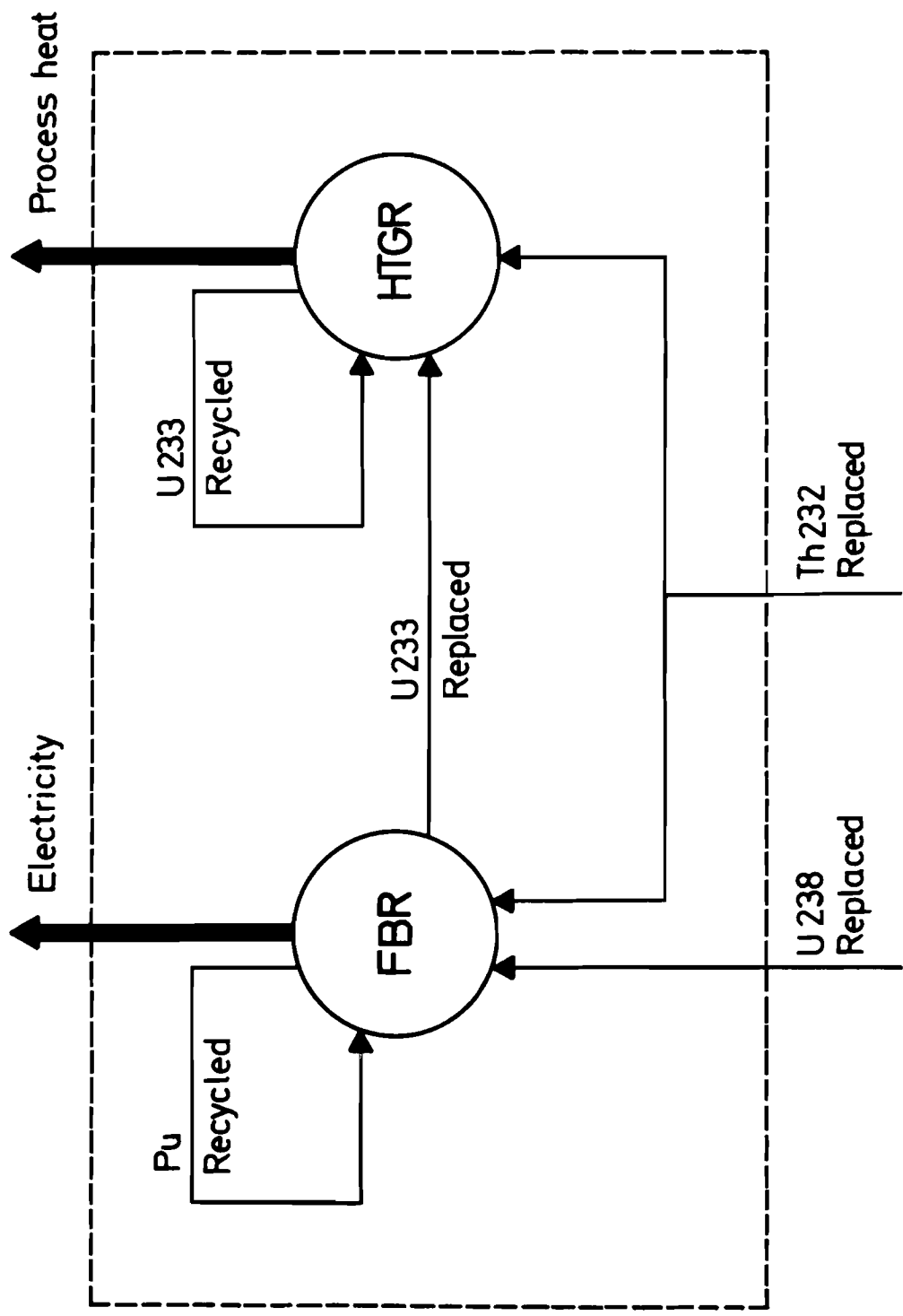

**Fig. 1.1 Asymptotic Integrated Power Reactor System**  
**Source: Ref. [1-3]**

of this paper is to maintain the perspective on the nuclear energy option in its entirety.

The structure of this paper is as follows. In the second chapter the mass flows of the nuclear material through the nuclear fuel cycle industry are analyzed for the asymptotic state represented in Fig. 1.1. In contrast to the original paper [1-3], it is assumed here that the primary energy demand is 10 kW thermal per capita, which for a society of 360 million people gives a total demand of  $3.6 * 10^{12}$  Watt thermal. In the third chapter the methodology is developed. Equations are given for the individual doses from point and volume sources (normal and accidental). With some assumptions on population density distributions around nuclear facilities, these equations are extended to population doses. In the fourth chapter the normal operations releases of radioactivity are considered. These releases are associated with the operations of the nuclear fuel cycle industry and are governed by the retention factors for the radioactive isotopes in the various nuclear fuel cycle facilities. In the past it has been predominantly the reactor that was of primary interest and the focus of vast research and development efforts. Only now are we at the advent of building a large scale commercial fuel cycle; the current problem of bringing a large commercial chemical reprocessing plant into operation is indicative for this kind of question. In the fifth chapter possible modes of accidental radioactive releases are analyzed; the problem of a final waste storage is treated separately in the sixth chapter because of its unique nature. Here, the question of the required degree of engineered safety against accidents plays a similar role as the retention factor mentioned above. In the seventh chapter, different kinds of sabotage and blackmail, including the construction of a nuclear explosive device, are analyzed. In the eighth chapter all calculations are summarized and evaluated in a preliminary manner. In the last chapter, a number of questions are addressed: What retention factors must be required in view of the long range evolution of nuclear power, and how do they relate to each other? Is the emphasis on reactor safety

excessive compared with that on physical protection against illegal diversion of fissionable material? What are the appropriate research and development priorities? What are the appropriate design objectives of engineered safety features? In other words a number of decision oriented assessments is identified that must be made when the large scale deployment of nuclear energy is envisioned.

For this purpose a procedure is outlined whereby the individual and population doses are fixed. The major assessments are made within the framework of these constraints. Finally, it must be emphasized that this work should be considered only as a first effort and is designed to stimulate further work along these directions.

Therefore it should be kept in mind that this paper is meant to be only one building block within a set of models that are designed to support decision making in the broader field of energy, with nuclear energy being only one option.

References for Chapter 1

- [1-1] W. Häfele  
Future Energy Resources  
Invited paper, World Energy Conference  
Detroit, September 1974  
International Institute for Applied Systems Analysis,  
Laxenburg, Austria, RR-74-20
- [1-2] W. Häfele  
A Systems Approach to Energy  
American Scientist, Vol. 62, No. 4  
July-August 1974, pp. 438-447
- [1-3] W. Häfele and W. Schikorr  
Reactor Strategies and the Energy Crisis  
International Atomic Energy Study Group on Reactor  
Strategy Calculations,  
Vienna, November 1973
- [1-4] W. Häfele and A.S. Manne  
Strategies for a Transition from Fossil to Nuclear Fuels  
International Institute for Applied Systems Analysis,  
Laxenburg, Austria, RR-74-7  
To be published in: Energy Policy
- [1-5] Jerome M. Weingart  
The Solar Option for Europe - A Long Term Perspective  
To be published as an IIASA Research Report, 1975
- [1-6] Environmental Survey of the Uranium Fuel Cycle  
U.S. Atomic Energy Commission  
Directorate of Licensing, Fuels and Materials  
WASH-1248, April 1974
- [1-7] Generic Environmental Statement Mixed Oxide (GESMO)  
U.S. Atomic Energy Commission  
WASH-report to be published
- [1-8] Environmental Analysis of the Uranium Fuel Cycle  
U.S. Environmental Protection Agency  
EPA - 520/9-73-003-B, C, and D  
Washington, November 1973

## 2. Description of Supporting Fuel Cycle

The operation of the asymptotic reactor system described in the preceding chapter presupposes a supporting fuel cycle with its associated facilities. Such a fuel cycle is shown in Fig. 2.1 with the various activities given as boxes. All of these activities, or boxes, are interconnected by transportation.

The mass balances for this fuel cycle have been calculated and are shown in Fig. 2.2. For the calculation, the following primary assumptions were made:

General - i) The fission of 1 gram of material produces  $0.95 \text{ MW}_{\text{th}}\text{d}$ ;

ii) Losses in fabrication and in reprocessing facilities for thorium, uranium, and plutonium are 0.5% each of the annual throughput; in total 1.0% of the annual throughput.

FBR System -

- i) 90% of the reactor power is produced in the core and axial blanket;
- ii) The average discharge burnup of the core is  $100,000 \text{ MW}_{\text{th}}\text{d/t}$ , and of the axial blanket  $3000 \text{ MW}_{\text{th}}\text{d/t}$ ; with core and axial blanket of equal masses the mixed discharge burnup is  $51,500 \text{ MW}_{\text{th}}\text{d/t}$ ;
- iii) The fissile plutonium content of the core and axial blanket mixed is 8%;
- iv) The neptunium-237, americium, and curium content of the core and axial blanket, at discharge, is 1.5 kg per ton of mixed core and axial blanket;
- v) The average discharge burnup of the radial blanket is  $10,000 \text{ MW}_{\text{th}}\text{d/t}$ ;
- vi) The radial blanket average production rate of U233 is  $0.12 \text{ t/GW}_{\text{th}}\text{y}$ ;
- vii) The protactinium-231 and neptunium-237 content of the radial blanket, at discharge, is 0.14 kg/t;
- viii) The core and axial blanket are self-supporting in fissile plutonium with an oversupply to compensate for process losses.



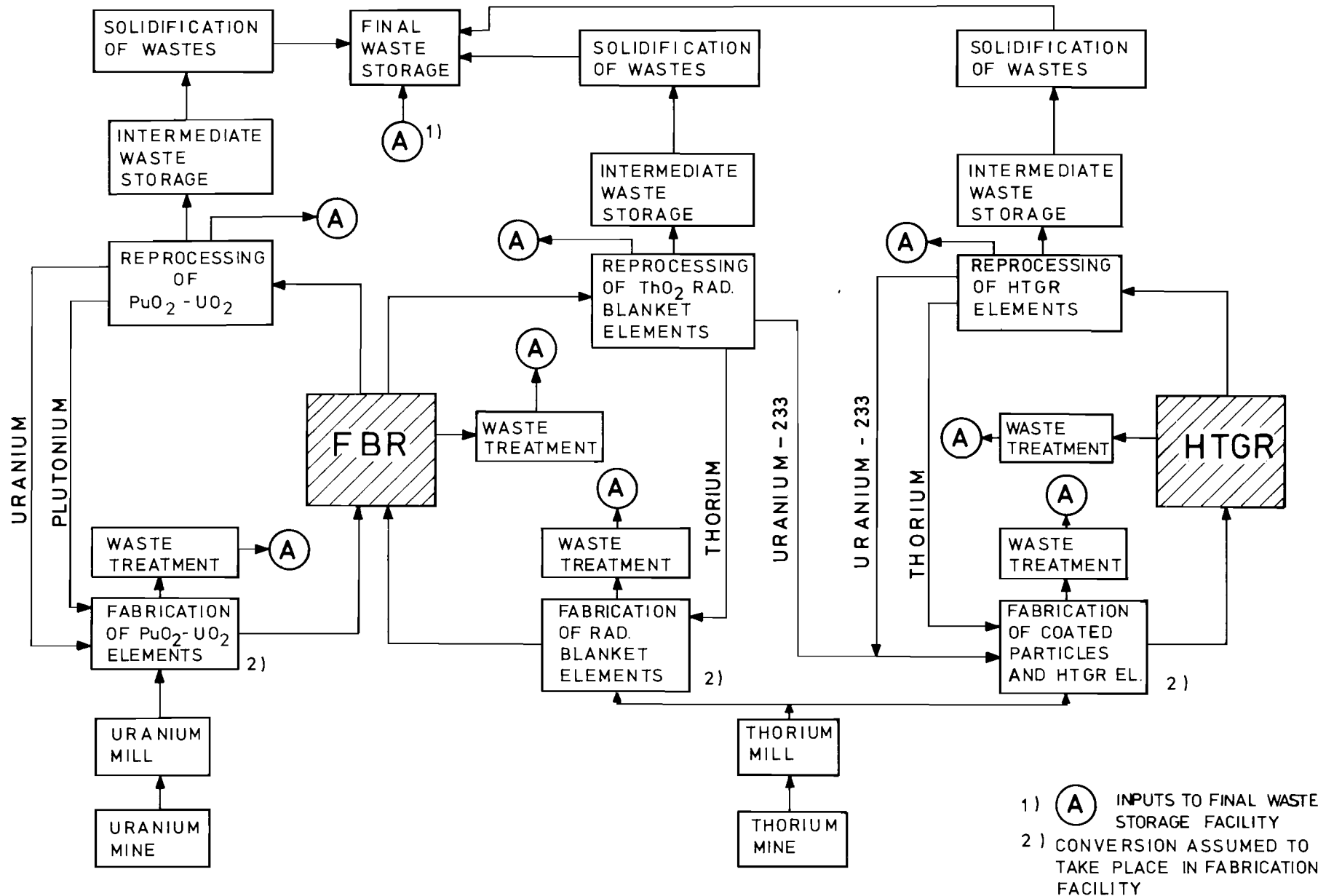
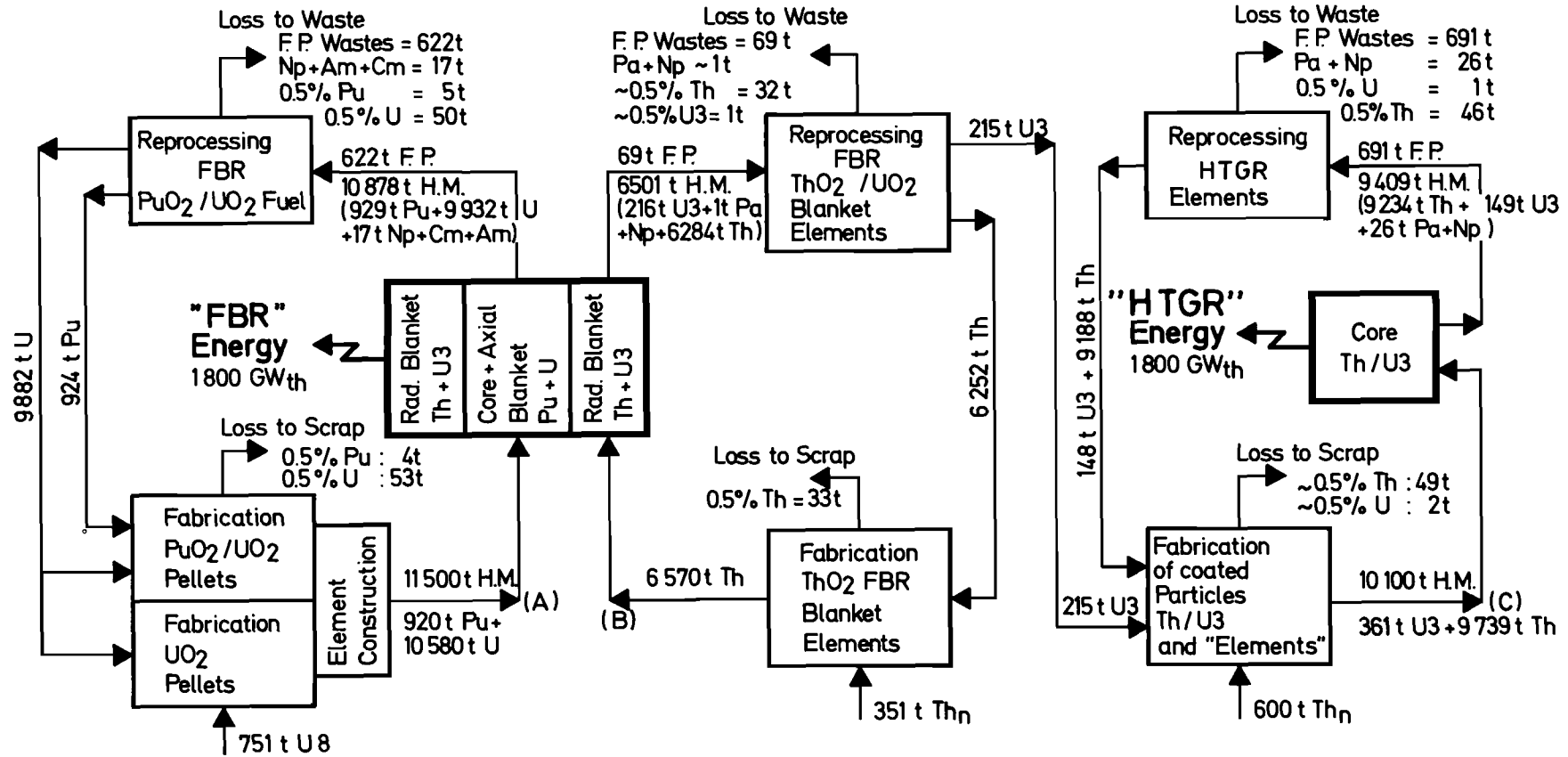

FIGURE 2.1 ASYMPTOTIC NUCLEAR FUEL CYCLE

**Fig. 2.2 Flow Chart : Asymptotic Integrated Reactor System**

( Yearly Throughputs )



HTGR System -

- i) The average discharge burnup of the fuel elements is  $65,000 \text{ MW}_{\text{th}} \text{d/t}$ ;
- ii) The protactinium-231 and neptunium-237 content of fuel at discharge is 2.6 kg/t;
- iii) The conversion rate of the HTGR is sufficient to balance U233 needs, and for the ratio of U233 makeup to U233 recycle (U233 from FBR/ U233 from HTGR) to be equal to 1.474.

In the results of Fig. 2.2 the reference to plutonium concerns only fissile plutonium; fertile plutonium is assimilated to natural uranium. In addition, in the HTGR system the U233 refers to all fissile uranium; fertile uranium is assimilated to thorium.

The calculation of the mass balance<sup>1)</sup> is shown in the following. The reference points for the calculation are shown in Fig. 2.2 as the points A, B and C. The calculation progresses in the direction of the arrows of the fuel cycle and represents annual quantities.

Point A:

- (a) Fuel quantity needed per year for FBR core and axial blanket

$$1800 \text{ GW}_{\text{th}} \text{y} * 0.9 * \frac{365 \text{ day/year}}{51.5 \text{ GW}_{\text{th}} \text{d/t}} = 11500 \text{ t/yr}$$

- (b) 8% of the fuel quantity is plutonium (fissile)

$$(a) * 0.08 = 11500 \text{ t} * 0.08 = 920 \text{ t/yr}$$

- (c) Total quantity of uranium (plus fertile plutonium)

$$(a) - (b) = 11500 \text{ t} - 920 \text{ t} = 10580 \text{ t/yr}$$

---

<sup>1)</sup> The mass defect which goes with the conversion of binding energy into mechanical energy upon fission is 1 ton per year.

- (d) Quantity of fission products produced in FBR core and axial blanket

$$1800\text{GW}_{\text{th}}\text{y} * 0.9 * \frac{365\text{d/y} * 10^{-3}\text{t/kg}}{0.95\text{GW}_{\text{th}}\text{d/kg}} = 622\text{t/yr}$$

- (e) Total amount of heavy metal out of the FBR core and axial blanket

$$(a) - (d) = 11500 - 622 = 10878\text{t/yr}$$

- (f) Total (fissile) plutonium out of FBR core and axial blanket must equal what goes in, (b), plus 1% to account for fabrication and reprocessing losses

$$(b) + 0.01 * (b) = 920 + 0.01 * 920 = 929\text{t/yr}$$

- (g) Total amount of neptunium-237, americium, and curium present in spent fuel

$$0.0015 * (a) = 0.0015 * 11500 = 17\text{t/yr}$$

- (h) Remaining quantity of uranium (plus fertile plutonium)

$$(e) - (f) - (g) = 10878 - 929 - 17 = 9932\text{t/yr}$$

- (i) Waste stream loss in reprocessing facility

- all fission products = (d) 622t/yr
- all Np + Am + Cm = (g) 17t/yr
- 0.5% of incoming plutonium =  $0.005 * (f)$  5t/yr
- 0.5% of incoming uranium =  $0.005 * (h)$  50t/yr

- (j) Quantity of plutonium out of reprocessing facility for reuse

$$(f) - (i) = 929 - 5 = 924\text{t/yr}$$

(k) Quantity of uranium out of reprocessing facility for reuse

$$(h) - (i) = 9932 - 50 = 9882\text{t/yr}$$

(l) Waste stream loss in fabrication facility

$$- 0.5\% \text{ of fabricated plutonium} = 0.005 * (b) = 4\text{t/yr}$$

$$- 0.5\% \text{ of fabricated uranium} = 0.005 * (c) = 53\text{t/yr}$$

(m) Makeup natural uranium required in fabrication facility

$$(c) + (l) - (k) = 10580 + 53 - 9882 = 751\text{t/yr}$$

Point B:

(a) Radial blanket fuel quantity needed per year for FBR (thorium)

$$1800\text{GW}_{\text{th}}\text{y} * 0.10 * \frac{365\text{d/y}}{10\text{GW}_{\text{th}}\text{d/t}} = 6570\text{t/yr}$$

(b) Total quantity of fission products

$$1800\text{GW}_{\text{th}}\text{y} * 0.10 * \frac{365\text{d/y} * 10^{-3}\text{kg/t}}{0.95\text{GW}_{\text{th}}\text{d/kg}} = 69\text{t/yr}$$

(c) Quantity of U233 produced in the radial blanket of the FBR

$$0.12\text{t/GW}_{\text{th}}\text{y} * 1800\text{GW}_{\text{th}}\text{y} = 216\text{t/yr}$$

(d) Protactinium-231 and neptunium-237 content of radial blanket at discharge

$$0.00014\text{t/t} * (a) = 0.00014 * 6570 = 0.92\text{t/yr}$$

(e) Total quantity of remaining thorium in radial blanket fuel

$$(a) - (b) - (c) - (d) = 6570 - 69 - 216 - 1 = 6284\text{t/yr}$$

(f) Waste stream loss in reprocessing facility for radial blanket elements

|  |        |
|--|--------|
| - all fission products = (b)             | 69t/yr |
| - all Pa + Np = (d)                      | 1t/yr  |
| - 0.5% of thorium incoming = 0.005 * (e) | 32t/yr |
| - 0.5% of U233 incoming = 0.005 * (c)    | 1t/yr  |

(g) Quantity of U233 out of reprocessing facility to HTGR fabrication facility

$$(c) - (f) = 216 - 1 = 215\text{t/yr}$$

(h) Quantity of thorium discharged from reprocessing facility

$$(e) - (f) = 6284 - 32 = 6252\text{t/yr}$$

(i) Waste stream loss in fabrication facility for thorium radial blanket for FBR

$$0.5\% \text{ of quantity fabricated} = 0.005 * (a) = 33\text{t/yr}$$

(j) Makeup thorium required at fabrication facility for radial blanket

$$(a) + (i) - (h) = 6570 + 33 - 6252 = 351\text{t/yr}$$

Point C:

(a) Fuel quantity needed per year for HTGR

$$1800\text{GW}_{\text{th}}\text{y} * \frac{365\text{d/y}}{65\text{GW}_{\text{th}}\text{d/t}} = 10100\text{t/yr}$$

(b) Quantity of U233 in fresh fuel

$$\begin{aligned}bm_0 &= \text{fissile material into HTGR} \\bm_1 &= \text{fissile material out of HTGR}\end{aligned}$$

from FBR calculation  $bm_0 - bm_1 = 215t$   
but  $(bm_0 - bm_1)/bm_1 = 1.474$

$$\begin{aligned}bm_1 &= 215/1.474 = 146t && 361t/yr \\bm_0 &= 215 + 146 = 361t\end{aligned}$$

(c) Quantity of thorium in fresh fuel

$$(a) - (b) = 10100 - 361 = 9739t/yr$$

(d) Amount of fission products

$$1800GW_{th}y * \frac{365d/y * 10^{-3}t/kg}{0.95GW_{th}d/kg} = 691t/yr$$

(e) Total heavy metal content of spent HTGR fuel

$$(a) - (d) = 10100 - 691 = 9409t/yr$$

(f) Protactinium-231 and neptunium-237 content of spent HTGR fuel at discharge

$$2.6kg/t * 10^{-3}t/kg * 10100t = 26t/yr$$

- (g) Content of U233 in spent HTGR fuel;  
sufficient to balance needs  
- in fabrication

0.5% loss = 2t U233

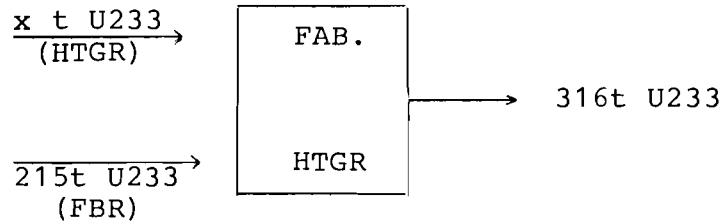

$$\begin{aligned} x \text{ t U233} &= 361 + 2 - 215 \\ &= 148 \text{ t U233} \end{aligned}$$

- in reprocessing

0.5% loss = 1t U233

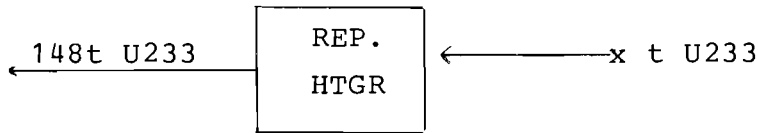

$$x \text{ t U233} = 148 \text{ t} + 1 \text{ t} = 149 \text{ t U233}$$

149t/yr

- (h) Thorium content of spent fuel, at discharge

$$(e) - (f) - (g) = 9409 - 26 - 149 = 9234 \text{ t/yr}$$

- (i) Waste stream loss in reprocessing facility

- all fission products = (d) 691t/yr
- all Pa + Np = (f) 26t/yr
- 0.5% of incoming thorium =  $0.005 * (h)$  46t/yr
- 0.5% of incoming U233 =  $0.005 * (g)$  1t/yr

- (j) Quantity of U233 to fabrication facility from reprocessing

$$(g) - (i) = 149 - 1 = 148 \text{ t/yr}$$



(k) Quantity of thorium to fabrication facility  
from reprocessing

$$(h) - (i) = 9234 - 46 = 9188\text{t/yr}$$

(l) Waste stream loss in fabrication facility  
for HTGR elements

$$\begin{aligned} - 0.5\% \text{ of thorium fabricated} &= 0.005 * (c) && 49\text{t/yr} \\ - 0.5\% \text{ of U233 fabricated} &= 0.005 * (b) && 2\text{t/yr} \end{aligned}$$

(m) Makeup thorium required at HTGR fabrication  
facility

$$(c) + (l) - (k) = 9739 + 49 - 9188 = 600\text{t/yr}$$

Literature Related to General Fuel Cycle Considerations

Simcha Golan and R. Salomon, "Nuclear Fuel Logistics",  
Nuclear News, February 1973, Vol. 16, No. 2.

"Siting of Fuel Reprocessing Plants and Waste Management  
Facilities", ORNL-4451, July 1970.

"An Evaluation of High-Temperature Gas-Cooled Reactors,"  
WASH-1085, December 1969.

"1000 MWe Liquid Metal Fast Breeder Reactor Follow-on  
Study," GEAP-5678, December 1968.

### 3. Radiation Doses

#### 3.1 Introduction

The nuclear facilities described in Chapter 2 are designed to provide all the primary energy of the model society. Associated with its production is the release of certain amounts of radioactivity either as normal operation losses or as accidental losses. Both types of releases lead to certain individual dose rates usually expressed in mrem/yr. In addition, a population dose rate, expressed in manrem/year, is considered; that is, the dose rate to the individual multiplied by the number of exposed persons. The two considerations reflect different points of view: the individual dose rate concept refers to the individual point of view, while the population dose rate concept may reflect a governmental point of view. For instance, the society as a whole may be particularly concerned, for genetic reasons, about the radiation received, while an individual may be concerned only with direct health impacts. In the following both aspects are evaluated.

The radiation exposure, and resulting dose rate to the individual and the population as a whole, is calculated by design in a rather simple manner. Releases of radionuclides to the atmosphere are assumed to represent a potential hazard only as long as they remain airborne (one exception is the treatment of iodine). Resuspension of the radionuclides after deposition is neglected, as is the transfer of the radionuclides along food chains (terrestrial and aquatic) and external irradiation (gamma) from the deposited radionuclides. Therefore, the mode of exposure is simply inhalation of radionuclides before deposition.

Releases of radionuclides to the hydrosphere are assumed to represent only an ingestion hazard from drinking contaminated water. The radiation exposure from immersion in water, as well as the external irradiation from standing near the contaminated water body, is neglected.

To include in an analysis the modes of radiation exposure neglected in this report it is necessary to perform a study involving a much greater complexity of treatment, such as

"The Year 2000 Study" [3-1] made for the USAEC. For such a study geography and demography must be explicitly delineated which, for the sake of generality, has been avoided in this work. However, "The Year 2000 Study" did not consider the great breadth of potential sources of radiation exposure considered in this report. An important point from Ref. [3-1] was that the inhalation of contaminated air and the drinking of contaminated water represented generally a significant fraction (>60%) of the total intake of radionuclides. The fact that not all modes of exposure are treated in this report does not invalidate the results and conclusions.

### 3.2 Point Sources

In many cases the source of the radioactivity released is a point source, the nuclear facility. In this case the method is developed in a highly schematized manner. It should be remembered however, that the results are considered necessary but not sufficient constraints for the handling of such releases. Sufficient constraints are developed for each particular case and require a special evaluation such as, those reported in the safety analyses of nuclear facilities. The basic problem, however, is in principle always the same: an emission  $Q$ [Curie/sec] is related by a meteorological dilution factor  $s$ [sec/m<sup>3</sup>] to an ambient air concentration  $D$ [Ci/m<sup>3</sup>]. This is related by an impact factor  $\rho$ [ $\frac{\text{mrem/Ci}}{\text{yr m}^3}$ ] to a particular individual dose rate  $B$ [ $\frac{\text{mrem}}{\text{yr}}$ ]. The impact factor  $\rho$  accounts for the biological effect of the radiation of a specific radioactive isotope.

The result is that one always has a relation of the following form:

$$\begin{array}{ccccccc}
 Q & * & s & * & \rho & = & B & (3-1) \\
 \left[ \frac{\text{Ci}}{\text{sec}} \right] & & \left[ \frac{\text{sec}}{\text{m}^3} \right] & & \left[ \frac{\text{mrem/yr}}{\text{Ci/m}^3} \right] & & \left[ \frac{\text{mrem}}{\text{yr}} \right] \\
 \text{Emission} & & \text{Meteorology} & & \text{Biology} & & \text{Individual} \\
 & & & & & & \text{dose rate}
 \end{array}$$

Various approaches for describing the meteorological process of dilution have been developed in the past, such as the Sutton formula or more recently the Pasquill formula (see Refs. [3-2] and [3-3]). Much sophistication was used to arrive at the most appropriate meteorological constants contained in these formulas. For the purpose of this work it is sufficient to employ throughout the paper simply an average value of  $s = 10^{-8}$  sec/m<sup>3</sup> for an individual at a distance of 10 km from the source. In many applications, the value of  $s$  ranges between  $10^{-7}$  and  $10^{-9}$ . In Appendix 2 typical meteorological configurations are given that result in a value of  $10^{-8}$ . In a few cases values other than  $10^{-8}$  are used, as explicitly stated in the text. The impact factor  $\rho$  can be obtained, for instance, from the data tables of the International Committee on Radiation Protection (Ref. [3-4]). This factor can be expressed as

$$\rho = \frac{500}{\text{MPC}_{500}} \left[ \frac{\text{mrem/yr}}{\text{Ci/m}^3} \right], \quad (3-2)$$

where  $\text{MPC}_{500}$  is the "maximum permissible concentration" of the radionuclide in air which would result in a dose rate of 500 mrem/yr if inhaled continuously.

For a mixture of isotopes equation (3-1) becomes

$$B = \sum_i \frac{Q_i}{\text{MPC}_{500}^i} * s * 500 \quad (3-1a)$$

when  $\text{MPC}_{500}^i$  is the "maximum permissible concentration" for the  $i$ -th isotope. The impact factor  $\rho$  reflects the distribution of the radiation in the body, the identification of a critical organ and the rate of biological damage per ambient activity concentration. It should be noted that by using this ratio, judgement on the absolute level of acceptable radiation dose rates has not been precluded. The problem of assessing an absolute level as a standard is a separate problem.

For normal operations losses the leak rate of radioactivity is  $Q$ [Ci/sec]. In an accident situation it is assumed that a finite amount  $C$ [Ci] of radioactivity is released and that the population is exposed to the related radiation for a limited time  $d$ [sec]. This means that a total of  $C \cdot d$  radioactive decays [Ci · sec] are considered. The arguments in this paper are based solely on expectation values. This implies a compensation of high and low values. We define  $C'$  to be the radioactive decays per second, averaged over one year, since the factor  $\rho$  refers to yearly rates:

$$C' = \frac{d}{3.15 \cdot 10^7} * C \text{ [Ci]} \quad .$$

If  $P$ [sec<sup>-1</sup>] is the probability per unit time for the accident in question to occur, a substitution leak rate can be defined:

$$Q = P * C' = P * \frac{d}{3.15 \cdot 10^7} * C \left[ \frac{\text{Ci}}{\text{sec}} \right] \quad , \quad (3-3)$$

that allows one to employ equation (3-1), within the scope of expectation values, also for accident situations.

### 3.3 Volume Sources

Sources cannot be approximated as point sources in all cases. Rare gases, for instance, diffuse into the entire atmosphere. The actual behavior is influenced by the half-life of the radioisotope in question. For the purposes of this paper an area  $F$  is envisioned for the model society. Above that area is a volume  $V$ [m<sup>3</sup>]. If  $Q$ [Ci/sec] is the leak rate of radioactivity into the volume  $V$ [m<sup>3</sup>] then the ambient activity concentration  $D$ [Ci/m<sup>3</sup>] is:

- for a half life  $T_{\frac{1}{2}}$  that is short enough for an equilibrium to be established but long enough to achieve a uniform distribution,

$$D = \frac{Q}{\lambda \cdot V} \left[ \frac{\text{Ci}}{\text{m}^3} \right] \quad , \quad (3-4)$$

Table 3-1. Percentage of pollutants in the atmosphere in the first 100 m above the land surface; after Bükér et al., Ref. [3-5].

| <u>Pollutant</u> | <u>%</u> |
|------------------|----------|
| SO <sub>2</sub>  | 15.0     |
| Dust             | 20.0     |
| NO <sub>2</sub>  | 17.0     |
| Fluorine         | 20.0     |
| CO               | 1.7      |
| CmHn             | 17.0     |
| Xe 133           | 7.5      |
| Kr 85            | 1.7      |

where  $\lambda[\text{sec}^{-1}]$  is the decay constant of the radioisotope in question ( $\lambda = \ln 2/T_{\frac{1}{2}}$ ); and

- for a half life that is long compared to the time periods considered (and long enough to achieve a uniform distribution),

$$D = \frac{Q \cdot t}{V} \left[ \frac{\text{Ci}}{\text{m}^3} \right] , \quad (3-5)$$

where  $t[\text{sec}]$  is the time considered.

For the model society, a volume of  $V = 10^{17} [\text{m}^3]$ , is assumed throughout. This may correspond to a surface area of  $F = 10^7 [\text{km}^2]$  and a height of  $10 [\text{km}]$ .

According to the barometric law radioactive isotopes are not distributed uniformly in the atmosphere. For our purposes only the first 100 m are of interest. Therefore, the fraction  $f$  in the atmosphere which remains within the first 100 m is given in Table 3-1 for different pollutants. With this correction, equation (3-4) becomes

$$D = \frac{Q * f}{\lambda * V} \left[ \frac{\text{Ci}}{\text{m}^3} \right] , \quad (3-4a)$$

and equation (3-5)

$$D = \frac{Q * t * f}{V} \left[ \frac{\text{Ci}}{\text{m}^3} \right] , \quad (3-5b)$$

where  $f$  is the value given in Table 3-1.

### 3.4 Population Densities and Doses

The application of the population dose concept requires information on the population density in the vicinity of the nuclear facility. Following J.R. Beattie [3-6] we assume:

#### A) Low population density

- 0- 8 km: 10,000 people total (50 people/km<sup>2</sup>)
- 8-16 km: 50,000 people total (82 people/km<sup>2</sup>)
- 16-65 km: 200,000 in a city and 60 people/km<sup>2</sup>



- B) Medium population density
  - 0- 8 km: 200,000 people total
  - 8-48 km: 1,000,000 people in a city and 120 people/km<sup>2</sup>
- C) High population density
  - constant 5,000 people/km<sup>2</sup>.

With this information the population density can be characterized as a function of the distance r from a source, f(r). Let BM[manrem/yr] be the population dose rate. Then for the case of a continuous point source

$$\begin{aligned}
 \text{BM} &= \Omega * 10^{-3} \cdot \rho * \int dF * s(r) * f(r) & (3-6) \\
 \left[ \frac{\text{manrem}}{\text{yr}} \right] & \left[ \frac{\text{Ci}}{\text{sec}} \right] \left[ \frac{\text{rem/yr}}{\text{Ci/m}^3} \right] & \left[ \text{km}^2 \right] \left[ \frac{\text{sec}}{\text{m}^3} \right] \left[ \frac{\text{man}}{\text{km}^2} \right] \cdot
 \end{aligned}$$

For the other cases considered the equation is developed accordingly.

It is sufficient for the purpose of this paper to evaluate the integral

$$J = \int dF * s(r) * f(r) \tag{3-7}$$

for the three cases A, B, C only once, keeping in mind that actual cases require a much more detailed procedure. In so doing it is assumed that:

- For radionuclide transport in air the wind blows in a 60° sector and has downwind characteristics of  $s(r) \sim \frac{1}{r^2}$ . This is, of course, only a rough representation of a frequent meteorological situation (where the power of r varies between -1.2 and -2.4, see Appendix 2);
- For radionuclide transport in groundwater the flow is in a 60° sector and has downflow characteristics of  $s(r) \sim r^{-\frac{1}{2}}$  (see formula A2-2).

The case of radionuclide transport in riverwater occurs only once (in Chapter 4) and is described there.

Therefore, one obtains the following:

- For the case of a reprocessing plant (low population density, case A, air) with

$$s(r) \sim \frac{1}{r^2} \quad \text{such that } s(r = 10 \text{ km}) = 10^{-8} \left[ \frac{\text{sec}}{\text{m}^3} \right]$$

$$f(r) = \begin{cases} f_1 = 50 \left[ \frac{\text{man}}{\text{km}^2} \right] & 1 \leq r \leq 8 \quad (= R') \\ f_2 = 82 \left[ \frac{\text{man}}{\text{km}^2} \right] & \text{for } 8 \leq r \leq 16 \quad (= R'') \\ f_3 = 74 \left[ \frac{\text{man}}{\text{km}^2} \right] & 16 \leq r \leq 65 \end{cases}$$

one gets

$$J_A^{\text{air}} = 2.8 * 10^{-4} \left[ \frac{\text{mansec}}{\text{m}^3} \right] ; \quad (3-7a)$$

- For the case of a final waste storage (low population density, case A, groundwater) with

$$s(r) = \frac{1}{2D\sqrt{2\pi KU}} \cdot \frac{1}{\sqrt{r}}$$

and

$$D = 10 [\text{m}], \quad U = 0.1 [\text{m/sec}], \quad K = 10^{-4} [\text{m/sec}]$$

one gets

$$J_A^{\text{groundwater}} = 1.7 * 10^{-4} \left[ \frac{\text{mansec}}{\text{m}^3} \right] ; \quad (3-7b)$$

- For the case of a reactor (medium population density, case B, air), with

$$s(r) \sim \frac{1}{r^2} \quad \text{such that } s(r = 10 [\text{km}]) = 10^{-8} \left[ \frac{\text{sec}}{\text{m}^3} \right]$$

$$f(r) = \begin{cases} f_1 = 1011 \left[ \frac{\text{man}}{\text{km}^2} \right] & 1 \leq r \leq 8 \\ f_2 = 262 \left[ \frac{\text{man}}{\text{km}^2} \right] & 8 \leq r \leq 48 \end{cases} \text{ for}$$

one gets

$$J_B^{\text{air}} = 2.7 * 10^{-3} \left[ \frac{\text{mansec}}{\text{m}^3} \right] ; \quad (3-7c)$$

- For the case of a city (high population density, case C, air) with

$$s(r) \sim \frac{1}{r^2} \text{ such that } s(r = 10 [\text{km}]) = 10^{-8} \left[ \frac{\text{sec}}{\text{m}^3} \right]$$

$$f(r) = 5000 \left[ \frac{\text{man}}{\text{km}^2} \right] , \quad R_1 = 0.01 [\text{km}] , \quad R_2 = 10 [\text{km}]$$

one gets

$$J_C^{\text{air}} = 3.6 * 10^{-2} \left[ \frac{\text{mansec}}{\text{m}^3} \right] . \quad (3-7d)$$

### 3.5 Number of Facilities

So far, leak rates or substitution leak rates for the entire nuclear fuel cycle have been considered, and thereby the effect on the entire model society. In order to examine the influence of subdividing these rates into leak rates of a number of facilities, we now consider the case of a reactor.

#### 3.5.1 Reactor leak rates due to normal operations losses

In the case of a single giant reactor, the normal operations releases Q are controlled such that the individual dose rate is not larger than a given value. Alternatively, consider n small reactors at n different sites, with the same total power output as the giant reactor, the releases of which are again controlled such that the related individual dose rates are not larger than a given value, which is the same as that above.

Then the case of the single giant reactor is certainly better than that of the  $n$  small reactors, where the population dose rate is  $n$  times as large. Realistic cases of radioactive releases may lie between these two cases [3-7].

### 3.5.2 Reactor leak rates due to accidental losses

Consider again the case of a single giant reactor where the accident probability is  $P$  and the substitute leak rate  $Q$  is controlled such that the individual dose rate is not larger than a given value. Alternatively, consider  $n$  small reactors at  $n$  different sites, and assume that the radioactive release of a single reactor, in case of an accident, is  $\frac{1}{n}$  of that of the giant reactor. If the accident probability of a small reactor is controlled such that the individual dose rate is not larger than a given value, which is the same as that of the giant reactor, then it is true that the accident probability of the small reactor is allowed to be  $n$  times that of the giant reactor. However, this is again at the expense of the society, as there are then  $n$  reactors and the population dose rate is accordingly  $n$  times as large as in the case of one giant reactor.

### 3.5.3 Number of facilities in the model society

It is assumed in the model fuel cycle that there exist:

- 100 reactor parks with  $36 \text{ GW}_{\text{th}}$  each (1000 reactor parks seem to pose insurmountable siting and waste heat disposal problems),
- 20 fabrication plants, and
- 20 reprocessing plants, each with a 1500 t/yr throughput (on the average),
- 140 intermediate waste storage facilities, i.e., 7 such storages for each reprocessing plant, and
- 10 final waste storage facilities.

References for Chapter 3

- [3-1] "The Potential Radiological Implications of Nuclear Facilities in the Upper Mississippi River Basin in the Year 2000," The Year 2000 Study, Division of Reactor Development and Technology, USAEC, WASH-1209 (January 1973)
- [3-2] F. Pasquill  
Atmospheric Diffusion  
D. Van Nostrand Company (1962)
- [3-3] D.H. Slade (Editor), Meteorology and Atomic Energy  
U.S. Government Printing Office (1968)
- [3-4] Recommendations of the International Commission on Radiological Protection, ICRP Publication 2  
Pergamon Press (1959)
- [3-5] H. Bükler et al.  
"Kernenergie und Umwelt"  
Jül-929-HT-WT, KFK-1366 (March 1973)
- [3-6] J.R. Beattie  
Methods for the Evaluation of Risks  
UKAEA Report, AH SB (S)-R-159 (1969)
- [3-7] B. Kahn et al.  
Radiological Surveillance Studies at a Pressurized Water Nuclear Power Reactor,  
U.S. Report EPA-Rep. RD 71-1 (August 1971)

#### 4. Normal Operations Releases

##### 4.1 Introduction

The normal operations releases from the facilities that compose the fuel cycle, as described in Chapter 2, are presented here with reference to present-day technology. It is assumed that four activities of the fuel cycle release significant amounts of radioactivity to the environment: reactor operation, fuel reprocessing, fuel fabrication, and waste solidification. Below, these four activities are considered separately for the FBR and HTGR reactor systems. The dose rates from these activities are considered for point sources and volume sources.

In all dose rate calculations the MPC values for air are used; in only two cases are those for water used. Most routine releases of facilities being designed today will be over the facilities' main stacks [4-1]. As mentioned earlier, an actual case requires an in-depth study that also takes into account other pathways of exposure than immersion in air (e.g., radionuclides can be concentrated by the aquatic food chain).

Both the individual dose rate  $B$  resulting from a single plant and the population dose rate  $BM$  resulting from all plants are considered. For reasons of comparison the natural background radiation exposure is considered; it is assumed to be

$$B_o = 110 \left[ \frac{\text{mrem}}{\text{yr}} \right] ,$$

and accordingly,

$$BM_o = 4 * 10^7 \left[ \frac{\text{manrem}}{\text{yr}} \right] .$$

The equations used in this section of the report are shown in Table 4-1.

TABLE 4-1: LIST OF FORMULAE USED IN CHAPTER 4

- 1) POINT SOURCE INDIVIDUAL DOSE RATE FROM A SINGLE PLANT

$$B_p = \sum_I \frac{Q_I}{MPC_I} * \frac{1}{3.15 * 10^7} * \frac{1}{RF} * 10^{-8} * 500$$

$$\left[ \frac{MREM}{YR} \right] \left[ \frac{CI}{YR} \frac{CI}{M^3} \right] \left[ \frac{YR}{SEC} \right] [1] \left[ \frac{SEC}{M^3} \right] \left[ \frac{MREM}{YR} \right]$$

- 2) POINT SOURCE POPULATION DOSE RATE FROM A SINGLE PLANT

$$B_{pM} = \sum_I \frac{Q_I}{MPC_I} * \frac{1}{3.15 * 10^7} * \frac{1}{RF} * 0.5 * I =$$

$$\left[ \frac{MANREM}{YR} \right] \left[ \frac{CI}{YR} \frac{CI}{M^3} \right] \left[ \frac{YR}{SEC} \right] [1] \left[ \frac{REM}{YR} \right] \left[ \frac{MANSEC}{M^3} \right]$$

$$= B_p * 10^5 * I$$

WHERE I IS GIVEN BY

$$I = \begin{cases} 2.8 * 10^{-4} & \text{FOR REPROCESSING, FABRICATION AND} \\ & \text{WASTE SOLIDIFICATION PLANTS} \\ 2.7 * 10^{-3} & \text{FOR REACTORS} \end{cases}$$

- 3) VOLUME SOURCE INDIVIDUAL DOSE RATE IN EQUILIBRIUM

$$B_{VE} = Q * \frac{1}{RF} * \frac{1}{0.693} * \frac{F}{V} * \frac{500}{MPC}$$

$$\left[ \frac{CI}{YR} \right] [1] [YR] \left[ \frac{1}{M^3} \right] \left[ \frac{MREM/CI}{YR} \frac{CI}{M^3} \right]$$

- 4) VOLUME SOURCE POPULATION DOSE RATE IN EQUILIBRIUM

$$B_{VE}^M = B_{VE} * 3.6 * 10^5 \left[ \frac{MANREM}{YR} \right]$$

- 5) INCREASING VOLUME SOURCE INDIVIDUAL DOSE RATE

$$B_{VI} = Q * \frac{1}{RF} * T * \frac{F}{V} * \frac{500}{MPC}$$

$$\left[ \frac{CI}{YR} \right] [1] [YR] \left[ \frac{1}{M^3} \right] \left[ \frac{MREM/CI}{YR} \frac{CI}{M^3} \right]$$

- 6) INCREASING VOLUME SOURCE POPULATION DOSE RATE

$$B_{VI}^M = B_{VI} * 10^{-3} * 3.6 * 10^8 \left[ \frac{MANREM}{YR} \right]$$

NORMALIZATION:  $\frac{B}{B_0} = \frac{B}{IU}$  AND  $\frac{B^M}{B_0^M} = \frac{B}{4 * 10^7}$

## 4.2 FBR Reactor Fuel Cycle

### 4.2.1 FBR reactor operation

The emission from an FBR reactor is assumed to consist primarily of krypton 85, xenon 133 and tritium. The specific release rates of Kr 85 and Xe 133 into air are in accordance with Ref. [4-2]:

$$\begin{aligned} \text{Kr 85} &: 0.018 \left[ \frac{\mu\text{Ci}}{\text{kWh}_e} \right] \\ \text{Xe 133} &: 2.85 \left[ \frac{\mu\text{Ci}}{\text{Wh}_e} \right] . \end{aligned}$$

These figures refer to a factual retention which is consistent with present-day technology.

If an energy production efficiency of 40% is assumed, then for the fast breeder reactors one has

$$1800 \left[ \text{GWyr}_{\text{th}} \right] = 6.3 * 10^{12} \left[ \text{kWh}_e \right] .$$

Data on tritium releases vary widely as they depend upon the particular situation; we take

$$\begin{aligned} \text{tritium into air} &: 200 \left[ \frac{\text{Ci}}{\text{yr} * 1000 \text{ MW}_e} \right] , \\ \text{tritium into water} &: 200 \left[ \frac{\text{Ci}}{\text{yr} * 1000 \text{ MW}_e} \right] . \end{aligned}$$

In Table 4-2 the data used in the calculations for the three radionuclides, as well as the resulting dose rates, are given. In the case of  $^3\text{H}$  dispersion into the air it is assumed that there is no volume source dose rate, as the tritium is washed out of the air and taken into the sea by the riverwater. In the case of  $^3\text{H}$  dispersion into the water there is, in effect, a sort of volume source dose rate as people use the riverwater for drinking. It is assumed that the total water flow of the major rivers on which the reactors are located is



TABLE 4-2: NORMAL OPERATIONS RELEASES OF FAST BREEDER REACTOR OPERATIONS\*)

|   | KRYPTON 85              | XENON 133              | TRITIUM INTO AIR       | TRITIUM INTO WATER     |
|---|-------------------------|------------------------|------------------------|------------------------|
| TOTAL RELEASE [Ci/YR]<br>FROM ALL FBR'S                                   | 1.135 * 10 <sup>5</sup> | 1.8 * 10 <sup>7</sup>  | 1.44 * 10 <sup>5</sup> | 1.44 * 10 <sup>5</sup> |
| HALF LIFE T [YR]  | 10.6                    | $\frac{5.3}{365}$      | 12.26                  | 12.26                  |
| MPC <sub>A</sub> [ $\frac{Ci}{M^3}$ ] $\hat{=}$ 500 [ $\frac{MREM}{YR}$ ] | 3 * 10 <sup>-7</sup>    | 3 * 10 <sup>-7</sup>   | 2 * 10 <sup>-7</sup>   | -                      |
| MPC <sub>w</sub> [ $\frac{Ci}{M^3}$ ] $\hat{=}$ 500 [ $\frac{MREM}{YR}$ ] | -                       | -                      | -                      | 3 * 10 <sup>-3</sup>   |
| POINT SOURCE DOSE RATE<br>FROM A SINGLE PLANT                             |                         |                        |                        |                        |
| B [MREM/YR]   | 1.2 * 10 <sup>-3</sup>  | 0.19                   | 2.3 * 10 <sup>-3</sup> |                        |
| B/B <sub>0</sub>  | 1.1 * 10 <sup>-5</sup>  | 1.7 * 10 <sup>-3</sup> | 2.1 * 10 <sup>-5</sup> |                        |
| BM [MANREM/YR]  | 0.32                    | 51.2                   | 0.62                   |                        |
| BM/BM <sub>0</sub>  | 8 * 10 <sup>-9</sup>    | 1.3 * 10 <sup>-6</sup> | 1.6 * 10 <sup>-8</sup> | -                      |
| VOLUME SOURCE DOSE RATE   |                         |                        |                        |                        |
| B [MREM/YR]   | 4.9 * 10 <sup>-2</sup>  | 4.7 * 10 <sup>-2</sup> |                        | 0.15                   |
| B/B <sub>0</sub>  | 4.5 * 10 <sup>-4</sup>  | 4.3 * 10 <sup>-4</sup> |                        | 1.4 * 10 <sup>-3</sup> |
| BM [MANREM/YR]  | 1.8 * 10 <sup>7</sup>   | 1.7 * 10 <sup>7</sup>  | -                      | 1.8 * 10 <sup>4</sup>  |
| BM/BM <sub>0</sub>  | 4.5 * 10 <sup>-4</sup>  | 4.3 * 10 <sup>-4</sup> |                        | 4.5 * 10 <sup>-4</sup> |

\*) THESE FIGURES REFER TO A FACTUAL RETENTION THAT IS CONSISTENT WITH TODAY'S TECHNOLOGY (SEE, E.G., REF. [4-2]).

5000 [ $\frac{m^3}{sec}$ ], and that one third of the population takes its drinking water from these rivers. Therefore, for the volume source individual dose rate from all fast breeder reactors one has

$$B = \frac{200}{3.15 * 10^7} * 720 * \frac{1}{5000} * \frac{500}{3 * 10^{-3}} = 0.15$$

$$\left[ \frac{Ci}{sec * GW_e} \right] \left[ GW_e \right] \left[ \frac{sec}{m^3} \right] \left[ \frac{mrem}{yr} / \frac{Ci}{m^3} \right] \left[ \frac{mrem}{yr} \right] ,$$

and accordingly,

$$BM = 0.15 * 1.2 * 10^8 * 10^{-3} = 1.8 * 10^4 \left[ \frac{manrem}{yr} \right] .$$

#### 4.2.2 FBR fuel reprocessing

In the reprocessing of the core, axial, and radial blankets, krypton 85, the iodines, and the actinides are of significant importance. The total quantity of fuel to be reprocessed from the core and blanket combined is about 18,000 tons per year.

In the calculation of the radioactivity releases from the facility it is assumed that the spent fuel is reprocessed 150 days after removal from the reactor. Therefore, the total radioactivity given in the following tables is that present in the fuel at the time it enters reprocessing (fuel element shearing, dissolution, etc.).

Krypton 85. The present state of technology in reprocessing activities results in the release of all Kr 85 present in the spent fuel elements (i.e., a retention factor RF = 1). Techniques for the collection of Kr 85 are, however, under development. The data utilized and the resultant dose rates are given in Table 4-3.

Tritium. Tritium presents a particular problem since it is extremely difficult to collect or to keep separate from the process water. The concepts at present being developed

TABLE 4-3: NORMAL OPERATIONS RELEASES OF FBR FUEL REPROCESSING OPERATIONS

|   | KRYPTON 85          | TRITIUM INTO AIR <sup>1)</sup> | TRITIUM INTO WATER <sup>1)</sup> | IODINES  | PLUTONIUM INTO WATER                              | ACTINIDES (EQU, Pu239) |
|---|---------------------|--------------------------------|----------------------------------|--|---|------------------------|
| TOTAL YEARLY ACTIVITY [Ci/YR]   | $1.38 \cdot 10^7$   | $1.72 \cdot 10^6$              | $1.72 \cdot 10^6$                | I131: $5.75 \cdot 10^3$<br>I129: $5.75 \cdot 10^1$ | 920 [TO/YR] $\hat{=}$<br>$6.3 \cdot 10^9$ [Ci/YR] | $3.82 \cdot 10^7$      |
| HALF LIFE [YR]  | 10.6                | 12.26                          | 12.26                            | I131: 8.05/365<br>I129: $17 \cdot 10^6$            | SEE TABLE 4-4                                     | $2.4 \cdot 10^4$       |
| MPCA $\left[ \frac{\text{Ci}}{\text{M}^3} \right] \hat{=} 500 \left[ \frac{\text{MREM}}{\text{YR}} \right]$             | $3 \cdot 10^{-7}$   | $2 \cdot 10^{-7}$              | -                                | 2)   | -   | $6 \cdot 10^{-14}$     |
| MPC <sub>w</sub> $\left[ \frac{\text{Ci}}{\text{M}^3} \right] \hat{=} 500 \left[ \frac{\text{MREM}}{\text{YR}} \right]$ | -                   | -                              | $3 \cdot 10^{-3}$                | -  | $1.26 \cdot 10^{-5}$                              | -                      |
| RETENTION FACTOR RF   | 1                   | $10^2$                         | $10^2$                           | $10^3$   | $10^7$  | $10^8$                 |
| POINT SOURCE DOSE RATE FROM 1 FACILITY  |                     |                                |                                  |  |   |                        |
| B [MREM/YR]   | 7.3                 | $1.37 \cdot 10^{-2}$           |                                  |  |   | 1.01                   |
| B/Bo  | 0.066               | $1.25 \cdot 10^{-4}$           | -                                | 2)   | -   | $10^{-3}$              |
| BM [MANREM/YR]  | $2 \cdot 10^2$      | 0.38                           |                                  |  |   | $2.8 \cdot 10^1$       |
| BM/BMo  | $5 \cdot 10^{-6}$   | $9.5 \cdot 10^{-9}$            |                                  |  |   | $7.0 \cdot 10^{-7}$    |
| VOLUME SOURCE DOSE RATE FROM 10 FACILITIES  |                     |                                |                                  |  |   |                        |
| B [MREM/YR]   | 6                   |                                | 0.18                             |  | 0.23  |                        |
| B/Bo  | $5.4 \cdot 10^{-2}$ | -                              | $1.6 \cdot 10^{-3}$              | 2)   | $2.1 \cdot 10^{-3}$                               | -                      |
| BM [MANREM/YR]  | $2.2 \cdot 10^7$    |                                | $2.2 \cdot 10^4$                 |  | $2.8 \cdot 10^4$                                  |                        |
| BM/BMo  | $5.4 \cdot 10^{-2}$ |                                | $5.4 \cdot 10^{-4}$              |  | $6.9 \cdot 10^{-4}$                               |                        |

1) ALTERNATIVELY, SEE TEXT, SECTION 4.2.2

2) SEE TEXT, SECTION 4.2.2

for fuel reprocessing facilities cannot be evaluated as yet. Therefore, two alternatives are considered: either all of the tritium goes into air, or all of it goes into water; in both cases the retention factor is  $RF = 10^{+2}$ . Tritium in water is treated in the same manner as in the case of the reactors. The data used and the resultant dose rates are given in Table 4-3.

Iodines. With present-day technology the iodines can be collected with a retention factor of about  $10^3$  (see Ref. [4-3]). Because of the short half life of iodine 131 ( $T_{\frac{1}{2}} = 8.05$  days) the cooling time of the spent fuel before reprocessing is an important factor in reducing the dose rate resulting from I 131. For the calculations, a fuel cooling time of 150 days was assumed, as mentioned previously. There are discussions at present which suggest cooling times of 250 days which would eliminate the I 131 problem completely.

In the dose rate calculations the MPC values of the ICRP for iodine were modified by a factor of 700 to account for the grass-cow-milk pathway to the thyroids of small children [4-4]. The results of the calculations indicate that the point source dose rate is not significant and may be neglected. Therefore, only the volume source dose rate resulting from the I 129 releases is considered.

In order to estimate the volume source dose rate it is assumed that the iodines released into the air, because of their reactivity, reach only a region within 10 km distance from the plant, and furthermore, that in the long run they will come to an equilibrium with all of the iodine in the biomass. As the biomass on land is about  $0.23 \text{ t/m}^2$  [4-5], and as the average iodine content in biomass (including water) is about 0.3 ppm [4-6], there is a relative build-up of  $1.62 * 10^{-4}$  per year, which could in principle last indefinitely. According to König [4-7] the fraction of I 129 in the thyroid should not be more than  $1.6 * 10^{-3}$ ; this means that for people who live exclusively from the biomass in the region around the reprocessing plant this limit will be exceeded after ten years.

Plutonium into water. According to our assumptions one reprocessing plant processes 92 t Pu per year; a representative isotope composition of the plutonium processes is given in Table 4-4. About 1% of the plutonium goes into the liquid waste, and approximately a fraction  $10^{-5}$  of this goes into the waste water. If it is assumed again that these waste waters feed into the main rivers, the dose rate can be calculated in the same manner as that for tritium. The results are given in Table 4-3.

Actinides into air. The release of the toxic, long half life actinides, such as I 129, also represents an irreversible commitment to the environment. It is assumed that the actinide mix in the off-gas is approximately the same as in the spent fuel at dissolution, where in terms of activity it is predominantly Pu 241 and Cm 242. For the dose calculations all actinides from T 1207 to Es 253 are considered. For the retention factor a value of  $10^8$  is assumed, as explained in the next section. The results have been converted to equivalent of Pu 239. Because of the short half life resident time of these isotopes in air (~ 5 days), the volume source dose rate can be neglected.

Consideration of a point source and transport in air is not totally satisfying as it does not take into detailed account the possible pathway of the actinides through the biosphere, nor the problem of a cumulative build-up which may be important in view of the long half lives of the actinides. Contrary to the case of iodine, where the factor of 700 allows for a rough account of such effects, such information is not available for the actinides.

#### 4.2.3 FBR fuel fabrication

According to the model fuel cycle, only uranium 238, thorium, and plutonium are handled in the FBR fuel fabrication plants. Of these, only plutonium poses a risk to the environment

In the fuel fabrication plant, airborne plutonium is caught in so-called absolute filters. Experiments in the Nuclear Research Center Karlsruhe [4-8] have indicated that

TABLE 4-4: TYPICAL PLUTONIUM MIXTURE

| PU-ISOTOPE | HALF LIFE TIME [YR] | FRACTION [%] | RADIOACTIVITY/ MASS UNIT ISO-TOPE [Ci/g ISO <sub>T</sub> ] | RADIOACTIVITY OF ISOTOPE PER MASS UNIT PU MIXTURE [Ci/g] | MPC <sub>A</sub> $\left[\frac{Ci}{M^3}\right]$<br>$\cong 500 \left[\frac{MREM}{YR}\right]$ | MPC <sub>W</sub> $\left[\frac{Ci}{M^3}\right]$<br>$\cong 500 \left[\frac{MREM}{YR}\right]$ |
|------------|---------------------|--------------|--|--|--|--|
| 238        | 86.4                | 1            | 16.07  | 0.1607   | $7 \cdot 10^{-14}$   | $5 \cdot 10^{-6}$  |
| 239        | $2.44 \cdot 10^4$   | 70           | 0.06   | 0.042  | $6 \cdot 10^{-14}$   | $5 \cdot 10^{-6}$  |
| 240        | 6600                | 21           | 0.218  | 0.0458   | $6 \cdot 10^{-14}$   | $5 \cdot 10^{-6}$  |
| 241        | 14                  | 6            | 109.1  | 6.546  | $3 \cdot 10^{-12}$   | $2 \cdot 10^{-4}$  |
| 242        | $3.8 \cdot 10^5$    | 2            | 0.004  | $0.8 \cdot 10^{-4}$                                      | $6 \cdot 10^{-14}$   | $5 \cdot 10^{-6}$  |

$$\text{AIR: } \sum_I \frac{Ci/g \text{ ISO}_T}{MPC_I} = 0.59 \cdot 10^{13} \left[ \frac{M^3}{G \text{ PU MIXTURE}} \right]$$

$$\text{WATER: } \sum_I \frac{Ci/g \text{ ISO}_T}{MPC_I} = 7.96 \cdot 10^4 \left[ \frac{M^3}{G \text{ PU MIXTURE}} \right]$$

about 0.1% of the plutonium throughput ends up in these filters. According to Ref. [4-9] the retention factor for these absolute filters is between  $10^4$  and  $10^5$ . Therefore, we conclude that not more than a fraction of  $10^{-8}$  of the throughput goes into the atmosphere. In the following, proportionality between the plutonium throughput and the amount of plutonium leaving the plant is assumed, although this may be questionable.

According to the assumptions in Chapter 3 there are 10 FBR fuel fabrication plants handling plutonium. Therefore, the annual throughput of one plant is about 100 t Pu. The isotope composition of the plutonium handled is given in Table 4-4. The results for the point source dose rate are given in Table 4-5; the volume source dose rate from plutonium in air may be neglected.

#### 4.2.4 FBR waste solidification

It is conceivable that almost any form of permanent waste storage scheme will first entail the solidification of the wastes, particularly the high-level liquid wastes. For economic reasons the solidification would not take place immediately after the spent fuel is reprocessed, but rather several years later. For our calculations it is assumed that the time period between reprocessing and solidification is five years.

At present several different processes are being investigated for the solidification of the wastes. Generally, however, the semi-volatiles such as ruthenium, cesium, selenium, tellurium and technetium can be off-gased because of the high temperatures used. The semi-volatiles would not remain in the air very long and would settle on the ground surrounding the facility.

For our purposes the four most important semi-volatiles are Ru 106, Te 125, Cs 134, and Cs 137. The summation of the ratios of their radioactivity (5 years after fuel reprocessing) to the corresponding  $MPC_a$  values is

$$\sum_i \frac{Q_i}{MPC_a} = 5.91 * 10^{14} * 1.8 * 10^4 = 1.06 * 10^{19}$$
$$\left[ \frac{Ci/t}{Ci/m^3} \right] \quad \left[ t/year \right] \quad \left[ m^3/year \right]$$

TABLE 4-5: NORMAL OPERATIONS RELEASES OF FBR FUEL FABRICATION

|   |   |
|---|---|
|   | PLUTONIUM WITH ISOTOPE COMPOSITION GIVEN IN TABLE 4-4 |
| ACTIVITY AVAILABLE IN 1 FACILITY  | 100 TO Pu<br>$\cong 6.8 * 10^8$ [Ci/YR]               |
| $\sum_I \frac{Q_I/G \text{ ISOTOPE}}{MPC_I} \left[ \frac{M^3}{G \text{ PU MIXTURE}} \right]$                      | $0.59 * 10^{13}$                                      |
| POINT SOURCE DOSE RATE FROM 1 FACILITY<br>B [MREM/YR]<br>B/B <sub>0</sub><br>BM [MANREM/YR]<br>BM/BM <sub>0</sub> | 1<br>$9.1 * 10^{-3}$<br>$2.8 * 10^1$<br>$7 * 10^{-7}$ |
| POPULATION DOSE RATE FROM 10 FACILITIES<br>BM [MANREM/YR]<br>BM/BM <sub>0</sub>                                   | $2.8 * 10^2$<br>$7 * 10^{-6}$                         |



for all waste solidification plants together. In equivalent Cs137 this amounts to  $Q = 5.3 * 10^9$  [Ci/yr] with  $MPC_a = 5 * 10^{-10}$  [Ci/m<sup>3</sup>]. Assuming one waste solidification plant for each reprocessing plant, there will be 10 FBR waste solidification plants in all. The individual and society point source dose rates are summarized in Table 4-6.

Again, the volume source dose rates may be neglected. But, as before, the problem of pathway accumulation and long-term behavior remains open.

#### 4.3 HTGR Reactor Fuel Cycle

Many of the considerations involved in this portion of the nuclear reactor energy system will be identical with those in the FBR portion. Therefore, only the important points will be outlined here.

##### 4.3.1 HTGR reactor operation

The specific release rates from the HTGR's are taken (see Ref. [4-2]) to be

$$\begin{aligned} \text{Kr 85} &: 0.075 \left[ \frac{\mu\text{Ci}}{\text{kW}_{\text{th}}} \right] \\ \text{Xe 133} &: 0.85 \left[ \frac{\mu\text{Ci}}{\text{kW}_{\text{th}}} \right] . \end{aligned}$$

Contrary to the FBR case, no tritium release into riverwater is assumed; we take

$$\text{tritium into air: } 1000 \left[ \frac{\text{Ci}}{\text{yr} * 1000 \text{ MW}_{\text{th}}} \right] .$$

In Table 4-7 the data used in the dose calculations, and the resulting dose rates, are presented.

##### 4.3.2 HTGR fuel reprocessing

The reprocessing technology for HTGR fuel is still being developed, but it is expected that releases will be comparable to those of existing facilities for reprocessing of light water

TABLE 4-6: NORMAL OPERATIONS RELEASES OF FBR WASTE SOLIDIFICATION

|   | EQUIVALENT Cs137  |
|---|---|
| TOTAL YEARLY ACTIVITY [Ci/YR]   | $5.3 * 10^8$  |
| HALF LIFE [YR]  | 30  |
| $MPC_A \left[ \frac{Ci}{M^3} \right] \cong 500 \left[ \frac{MREM}{YR} \right]$                                  | $5 * 10^{-10}$  |
| RETENTION FACTOR RF   | $10^5$  |
| POINT SOURCE DOSE RATE FROM 1 FACILITY<br>B [MREM/YR]<br>$\frac{B}{B_0}$<br>BM [MANREM/YR]<br>$\frac{BM}{BM_0}$ | 1.7<br>$1.5 * 10^{-2}$<br>$4.65 * 10^1$<br>$1.16 * 10^{-6}$ |
| POINT SOURCE DOSE RATE FROM ALL FACILITIES<br>BM [MANREM/YR]<br>BM/BM <sub>0</sub>                              | $4.65 * 10^2$<br>$1.16 * 10^{-5}$                           |

TABLE 4-7: NORMAL OPERATIONS RELEASES OF HIGH TEMPERATURE GAS COOLED REACTORS\*)

|   | KRYPTON 85          | XENON 133            | TRITIUM INTO AIR    |
|---|---------------------|----------------------|---------------------|
| TOTAL RELEASE FROM ALL MTGR'S [CI/YR]   | $1.2 \cdot 10^6$    | $1.3 \cdot 10^7$     | $2.88 \cdot 10^5$   |
| HALF LIFE T [YR]  | 10.6                | $\frac{5.3}{365}$    | 12.26               |
| MPCA $\left[ \frac{CI}{M^3} \right] \cong 500 \left[ \frac{MREM}{YR} \right]$ | $3 \cdot 10^{-7}$   | $3 \cdot 10^{-7}$    | $2 \cdot 10^{-7}$   |
| POINT SOURCE DOSE RATE FROM A SINGLE PLANT                                    |                     |                      |                     |
| B [MREM/YR]   | $1.3 \cdot 10^{-2}$ | 0.14                 | $4.6 \cdot 10^{-3}$ |
| B/Bo  | $1.2 \cdot 10^{-4}$ | $1.2 \cdot 10^{-3}$  | $4.2 \cdot 10^{-5}$ |
| BM [MANREM/YR]  | 3.4                 | 37                   | 1.24                |
| BM/BMo  | $8.5 \cdot 10^{-8}$ | $0.94 \cdot 10^{-6}$ | $3.2 \cdot 10^{-8}$ |
| VOLUME SOURCE DOSE RATE   |                     |                      |                     |
| B [MREM/YR]   | 0.52                | $3.4 \cdot 10^{-2}$  | -                   |
| B/Bo  | $4.8 \cdot 10^{-3}$ | $3.1 \cdot 10^{-4}$  | -                   |
| BM [MANREM/YR]  | $1.9 \cdot 10^8$    | $1.2 \cdot 10^7$     | -                   |
| BM/BMo  | $4.8 \cdot 10^{-3}$ | $3.1 \cdot 10^{-4}$  | -                   |

\*) THESE FIGURES REFER TO A FACTUAL RETENTION THAT IS CONSISTENT WITH TODAY'S TECHNOLOGY (SEE, E.G., REF [4-2] ).

reactor fuel. Based on this assumption, the dose rates for the same isotope as considered for the reprocessing of FBR fuel were calculated. The specific iodine releases were assumed to be (for one facility):

$$I_{131}: 2.73 * 10^3 [Ci/yr]$$

and

$$I_{129}: 1.05 * 10^1 [Ci/yr] .$$

As they are of the same order of magnitude as those in the case of FBR fuel reprocessing facilities, the same arguments are valid.

The data used and the results of calculations for the HTGR reprocessing plant are given in Table 4-8.

#### 4.3.3 HTGR fuel fabrication

Because of the similar radiological behavior of plutonium and uranium 233, it is assumed that the arguments valid in the case of FBR fuel fabrication are also valid for HTGR fuel fabrication. However, as the MPC value of uranium 233 is 3 orders of magnitude larger than that of plutonium, and as the resulting doses from FBR fuel fabrication were small, these doses can be neglected.

#### 4.3.4 HTGR waste solidification

As in the FBR portion of the fuel cycle, it is assumed that solidification of the HTGR wastes will take place roughly 5 years after the spent fuel is reprocessed. The four most important semi-volatiles are again Ru 106, Te 125, Cs 134, and Cs 137. The summation of the ratios of their radioactivity (5 years after fuel reprocessing) to the corresponding MPC<sub>a</sub> values is

$$\sum_i \frac{Q_i}{MPC_a^i} = 5.98 * 10^{14} * 1.01 * 10^4 = 6.04 * 10^{18} .$$
$$\left[ \frac{Ci/t}{Ci/m^3} \right] \quad \left[ \frac{t}{yr} \right] \quad \left[ m^3/year \right]$$

TABLE 4-8: NORMAL OPERATIONS RELEASES OF HTGR FUEL REPROCESSING OPERATIONS

|  | KRYPTON 85          | TRITIUM INTO AIR <sup>1)</sup> | TRITIUM INTO WATER <sup>1)</sup> | URANIUM 233 INTO WATER                     | ACTINIDES (EQU. Pu 239) |
|--|---------------------|--------------------------------|----------------------------------|--|-------------------------|
| TOTAL YEARLY ACTIVITY [Ci/YR]  | $4.95 \cdot 10^7$   | $8.51 \cdot 10^5$              | $8.51 \cdot 10^5$                | $365 [To/YR] \hat{=} 5 \cdot 10^7 [Ci/YR]$ | $1.91 \cdot 10^7$       |
| HALF LIFE [YR]   | 10.6                | 12.26                          | 12.26                            | $1.62 \cdot 10^5$                          | $2.4 \cdot 10^4$        |
| $MPC_A \left[ \frac{Ci}{M^3} \right] \hat{=} 500 \left[ \frac{MREM}{YR} \right]$ | $3 \cdot 10^{-7}$   | $2 \cdot 10^{-7}$              | -                                | -  | $6 \cdot 10^{-14}$      |
| $PPC_W \left[ \frac{Ci}{M^3} \right] \hat{=} 500 \left[ \frac{MREM}{YR} \right]$ | -                   | -                              | $3 \cdot 10^{-3}$                | $3 \cdot 10^{-5}$                          | -                       |
| RETENTION FACTOR RF  | 1                   | $10^2$                         | $10^2$                           | $10^7$                                     | $10^8$                  |
| POINT SOURCE DOSE RATE FROM 1 FACILITY   |                     |                                |                                  |  |                         |
| B [MREM/YR]  | 26                  | $6.7 \cdot 10^{-3}$            |                                  |  | 0.5                     |
| B/Bo   | 0.24                | $6.1 \cdot 10^{-5}$            | -                                | -  | $5 \cdot 10^{-4}$       |
| BM [MANREM/YR]   | $7.2 \cdot 10^2$    | 0.19                           |                                  |  | $1.4 \cdot 10^2$        |
| BM/BMo   | $1.8 \cdot 10^{-5}$ | $4.7 \cdot 10^{-9}$            |                                  |  | $3.5 \cdot 10^{-7}$     |
| VOLUME SOURCE DOSE RATE FROM 10 FACILITIES                                       |                     |                                |                                  |  |                         |
| B [MREM/YR]  | 21                  |                                | $8.8 \cdot 10^{-2}$              | $5.3 \cdot 10^{-4}$                        |                         |
| B/Bo   | 0.19                |                                | $7.8 \cdot 10^{-4}$              | $4.8 \cdot 10^{-6}$                        |                         |
| BM [MANREM/YR]   | $7.6 \cdot 10^6$    | -                              | $1.7 \cdot 10^4$                 | $1.9 \cdot 10^2$                           |                         |
| BM/BMo   | 0.19                |                                | $2.6 \cdot 10^{-4}$              | $1.6 \cdot 10^{-6}$                        |                         |

<sup>1)</sup> ALTERNATIVELY, SEE TEXT, SECTION 4.3.2

In equivalent Cs137 this amounts to  $Q = 3.02 * 10^9$  [Ci/yr] with  $MPC_a = 5 * 10^{-10}$  [Ci/m<sup>3</sup>]. The individual and population dose rates are summarized in Table 4-9.

TABLE 4-9: NORMAL OPERATIONS RELEASES OF HTGR WASTE SOLIDIFICATION

|   | EQUIVALENT Cs137   |
|---|--|
| TOTAL YEARLY ACTIVITY [Ci/YR]   | $3.02 * 10^8$  |
| HALF LIFE [YR]  | 30   |
| $MPC_A \left[ \frac{Ci}{M^3} \right] \cong 500 \left[ \frac{MREM}{YR} \right]$                                  | $5 * 10^{-10}$   |
| RETENTION FACTOR RF   | $10^5$   |
| POINT SOURCE DOSE RATE FROM 1 FACILITY<br>B [MREM/YR]<br>$\frac{B}{B_0}$<br>BM [MANREM/YR]<br>$\frac{BM}{BM_0}$ | 0.96<br>$8.7 * 10^{-3}$<br>$2.65 * 10^1$<br>$6.63 * 10^{-7}$ |
| POINT SOURCE DOSE RATE FROM ALL FACILITIES<br>BM [MANREM/YR]<br>BM/BM <sub>0</sub>                              | $2.65 * 10^2$<br>$6.63 * 10^{-6}$                            |

References for Chapter 4

- [4-1] J.L. Russel and Floyd L. Galpin  
"A Review of Measured and Estimated Off Site Doses  
at Fuel Reprocessing Plants" in Proceedings of a  
Symposium on Management of Radioactive Wastes from  
Fuel Reprocessing, OECD/IAEA,  
Paris, December 1972
- [4-2] See Ref. [3-5]
- [4-3] "The Safety of Nuclear Power Reactors (Light Water-  
Cooled) and Related Facilities,"  
WASH-1250, July 1973
- [4-4] T.J. Burnett  
"A Derivation of the 'Factor of 700' for  $^{131}\text{I}$ ,"  
Health Physics, Vol. 18, pp. 73-75 (1970)
- [4-5] Handbook of Chemistry and Physics, 55th Edition,  
p. F181. Chemical Rubber Publishing Company,  
Cleveland, Ohio, 1974
- [4-6] H. Kinzel  
Pflanzenphysiologisches Institut, University of Vienna,  
personal communication
- [4-7] L.A. König  
"Umweltaspekte von I129"  
KFK 1543 (1972)
- [4-8] W.W. Gmelin and R. Kraemer  
"Analysis of Components of Material Unaccounted For"  
in Proceedings of a Symposium on Safeguards Techniques  
IAEA, Karlsruhe, June 1970
- [4-9] Prüfberichte des Staubforschungsinstituts des Haupt-  
verbandes der gewerblichen Berufsgenossenschaften e.V.,  
Bonn, FRG



## 5. Accidental Releases

### 5.1 Introduction

In addition to normal operations releases, accidental releases must also be considered. In Chapter 3 the substitution release rate  $P * \frac{d}{3.15 * 10^7} * C$  was introduced which allows one to use equation (3-3). In recent years much effort has been put into the calculation of values for P by applying failure tree analysis [5-1], [5-2], [5-3] and methods of reliability control [5-4]. There exists today a fairly large body of data and information. A constant difficulty is the lack of data on the failure rate of each component of the failure tree and on the probability distribution of these failure rates. A second difficulty is the lack of radiation exposure standards, or guidelines, for the case of a nuclear accident as there are for radiation doses resulting from normal operations releases.

For these two reasons a normative approach is followed in the next three chapters, contrary to the procedure in the foregoing chapter. This means that a particular individual dose rate is fixed and the required accident probability is calculated which fulfills this requirement. We will, however, rigorously use the scheme of expected values. This is instrumental for developing a judgement on the relative importance of the various components of the fuel cycle as far as accidents are concerned. It is clear that the procedure of using expected values can lead only to necessary, but not sufficient, conditions. In addition, it leads to conceptual difficulties that will be alluded to in the concluding chapter. Finally, in each actual case additional and more stringent conditions may have to be observed, even within the scheme of expectation values.

For the individual radiation dose rates that may be tolerable in the event of an accident, it is common to assume a dose rate of 25 rem over a period of 70 years (see Ref. [5-5]). The problem is then to seek the probability P per unit time [sec] which is equivalent to 25000/70[mrem/yr]. Both the probability

P and the dose rate B can, within the framework of the methodology based on expectation values, be smoothed out over any period of time. That is, it is postulated that the following point source relation holds:

$$P * \frac{d}{3.15 * 10^7} * 500 * \sum_i \frac{C_i}{MPC_i} * s = \frac{25000}{70} \quad (5-1)$$

$$\left[ \frac{1}{\text{sec}} \right] \quad [1] \quad \left[ \frac{\text{mrem}}{\text{yr}} \right] \left[ \frac{C_i/C_i}{\text{m}^3} \right] \left[ \frac{\text{sec}}{\text{m}^3} \right] \left[ \frac{\text{mrem}}{\text{yr}} \right] .$$

It is clear that P must be smaller than  $(70 \text{ yr} * 3.15 * 10^7)^{-1} [\text{sec}^{-1}]$ . If P becomes larger than this value then the following relations must be used:

$$P = \frac{a}{70 * 3.15 * 10^7} , \quad a > 1 \quad (5-2a)$$

$$\frac{a}{70 * 3.15 * 10^7} * \frac{d}{3.15 * 10^7} * 500 * \sum_i \frac{C_i}{MPC_i} * s = \frac{25000}{70 * a} . \quad (5-2b)$$

That is, a fraction of  $\frac{25}{a}[\text{rem}]$  is assumed for each accident, and thereby a total of 25 rem over 70 years. For the purpose of comparison, the natural background radiation leads to an individual dose of  $0.11 * 70 = 8[\text{rem}]$ .

Either equation (5-1) or equation (5-2) can be used to find a value of P that must be postulated. The notation  $P_D^0$  will be used to denote this value.

## 5.2 Reactor Accidents

The concept of the maximum credible accident, MCA, prevailed for a long time (see [5-6], [5-7]); thus the reactor had to be designed such as to contain the accident, possibly with somewhat enhanced leakages of radioactivity. Accidents more severe than the maximum credible accident were considered inconceivable. Later, the trend was to consider even inconceivable accidents, and the spectrum of severity then became open-ended. This necessitated the definition of a design basis

accident, DBA. A rigorous look at the meaning of this led to the observation that the probability  $P_R$  for any accident more severe than the DBA must be smaller than the probability  $P_D$  of the DBA,

$$P_R < P_D \quad . \quad (5-3)$$

A precise specification of a DBA would therefore have to include the numerical value for  $P_D$ . By appropriate technological measures  $P_D$  can be made smaller than any given positive small number  $\epsilon$ . It is not possible, however, to make  $\epsilon$  exactly zero. The open-endedness of the consideration of reactor accidents therefore leads to the concept of a residual risk, that is, reactor accidents with probabilities smaller than  $\epsilon$ . These accidents will be called the trans design basis accidents, TDBA.

The conceptual difficulties of dealing with extremely small numbers have recently been discussed by one of the authors [5-8]. One must realize, however, that, rightly or wrongly, the public is concerned with the TDBA's.

In the following, certain normative target values are imposed on the DBA's which refer to the actual design of a reactor. As already mentioned, such a procedure refers to the TDBA's only implicitly by assuming that an ordering of the level of the DBA is equally significant for the level of the TDBA. With this in mind the following assumptions for the DBA are made:

- a) The value of  $P_D^0$  is independent of the size of a nuclear power station;
- b) The release of radioactivity to the outside of the reactor containment is assumed to occur only 5 minutes after the accident is initiated;
- c) The exposure time for individuals in the vicinity of the reactor is assumed to be  $1.8 * 10^5$  sec, or 50 hours;
- d) In the event of an accident, it is assumed that the total iodine inventory of the reactor is released to the atmosphere. Actually, much less is expected to be released in the event of a DBA. By considering

this very pessimistic scenario, conservative values for the normative probabilities  $P_D^O$  are calculated. A higher value of  $P_D^O$  would result if less radioactivity were released;

- e) The population density of the nuclear power station is that of Class B in Chapter 3.

If one assumes for the moment that there exists only one giant nuclear power station, then the basic equation (5-1) reads as follows:

$$P_D^O * \frac{C_{I131}}{MPC_{I131}} * L * \frac{d}{3.1 * 10^7} * s * 500 = \frac{25000}{70} \quad (5-4)$$

$$\left[ \frac{1}{\text{sec}} \right] \left[ \frac{\text{m}^3}{W_{\text{th}}} \right] [W_{\text{th}}] \left[ \frac{\text{sec}}{\text{sec}} \right] \left[ \frac{\text{sec}}{\text{m}^3} \right] \left[ \frac{\text{mrem}}{\text{yr}} \right] \left[ \frac{\text{mrem}}{\text{yr}} \right] ,$$

where L is the thermal power of the nuclear power station. Using the average value for iodine,

$$\frac{C_{I131}}{MPC_{I131}} \approx 10^8 \left[ \frac{\text{m}^3}{W_{\text{th}}} \right]$$

(where the value of  $MPC_{I131}$  does not include the factor 700 for the grass-cow-milk pathway as in accident situations the utilization of contaminated milk is avoidable), and  $L = 3.6 * 10^{12}$  [W], one finds

$$P_D^O = 3.4 * 10^{-11} \left[ \frac{1}{\text{sec}} \right] = 1.1 * 10^{-3} \left[ \frac{1}{\text{yr}} \right] . \quad (5-5)$$

If instead of one giant reactor there are 100 reactors, then for each of these reactors

$$P_D^{O'} * \frac{C_{I131}}{MPC_{I131}} * \frac{L}{100} * \frac{d}{3.1 * 10^7} * s * 500 = \frac{25000}{70} ,$$

which leads to

$$P_D^O = \frac{a}{70} = 0.04 \left[ \frac{1}{\text{yr}} \right] .$$

The population dose rate  $BM'$  for one of these 100 power stations is, according to equation (3-6)

$$BM' = P_D^O \cdot \frac{C_{I131}}{MPC_{I131}} \cdot \frac{L}{100} \cdot \frac{d}{3.15 \cdot 10^7} \cdot 0.5 \cdot J_B^{\text{air}} \quad (5-6)$$

$$\left[ \frac{\text{manrem}}{\text{yr}} \right] \quad \left[ \frac{1}{\text{sec}} \right] \quad \left[ \frac{\text{m}^3}{\text{W}_{\text{th}}} \right] \quad \left[ \text{W}_{\text{th}} \right] \quad \left[ \frac{\text{sec}}{\text{sec}} \right] \quad \left[ \frac{\text{rem}}{\text{yr}} \right] \left[ \frac{\text{mansec}}{\text{m}^3} \right] .$$

With the value (3-7c) for the population density integral one arrives at

$$BM' = 3.5 \cdot 10^4 \left[ \frac{\text{manrem}}{\text{yr}} \right] ;$$

for the total population dose rate one finds

$$BM = 100 \cdot BM' = 3.5 \cdot 10^6 \left[ \frac{\text{manrem}}{\text{yr}} \right] ,$$

and

$$BM/BM_0 = 8.8 \cdot 10^{-2} .$$

In view of this high  $BM/BM_0$  ratio it might appear questionable whether, in reality, the factor 100 should be used in equation (5-5). On the other hand, one must realize that present reactor engineering practices result in values for  $P$  that are lower than  $P_D^O$  by orders of magnitude. This has been highlighted by the recent Rasmussen Report [5-3]. In the last chapter of this paper, the obvious discrepancies between present engineering practice and our normative approach are discussed.

### 5.3 Reprocessing Facility Accidents

Many kinds of accidents are possible in a reprocessing plant. It is assumed here that the accidental releases would be characterized by the volatiles and semi-volatile compounds of the nuclear material in process. The following assumptions are made:

- a) In the event of a severe accident 5% of all fission products and 1% of the heavy metals present in process are released;
- b) The exposure time for individuals in the vicinity of the plant is assumed to be  $1.8 * 10^5$  sec or 50 hours;
- c) The material in process is  $\frac{1}{300}$  of the total yearly throughput;
- d) At the site of the reprocessing plant there are assumed to be 7 intermediate liquid waste storages. Because there exists for each of these intermediate liquid waste storages a non-zero accident probability, and because the people in the vicinity of the plant must not receive more than an expected accidental dose of 25 rem over 70 years, the total amount is distributed as follows:

$$\frac{10}{70} \left[ \frac{\text{rem}}{\text{yr}} \right] \text{ for the reprocessing plant,}$$

$$\frac{2}{70} \left[ \frac{\text{rem}}{\text{yr}} \right] \text{ for each liquid waste tank at the site of the reprocessing plant;}$$

- e) The population density in the vicinity of the plant is that of Class A in Chapter 3.

According to assumption b), inventories A of the reprocessing plants are:

$$A_{\text{FBR}} = \frac{1}{300} * (1.08 + 0.65 + 0.06) * 10^4 = 60.2[\text{t}]$$

Heavy metals    Fission prod.

$$A_{\text{HTGR}} = \frac{1}{300} * (0.94 + 0.07) * 10^4 = 33.7[\text{t}]$$

Heavy metals    Fission prod.

A summation of the radioactivity from 5% of the fission products and 1% of the heavy metals present in these fuels, divided by the corresponding MPC values, gives the dilution volume per ton:

$$\sum_i \frac{C_i}{\text{MPC}_i} /_{\text{FBR}} = 3.84 * 10^{15} \left[ \frac{\text{m}^3}{\text{t}} \right] ,$$

$$\sum_i \frac{C_i}{\text{MPC}_i} /_{\text{HTGR}} = 1.93 * 10^{15} \left[ \frac{\text{m}^3}{\text{t}} \right] .$$

If there is only one giant reprocessing plant then equation (3-1), with equation (3-3) and

$$\begin{aligned} C &= \sum_i \frac{C_i}{\text{MPC}_i} /_{\text{FBR}} * A_{\text{FBR}} + \sum_i \frac{C_i}{\text{MPC}_i} /_{\text{HTGR}} * A_{\text{HTGR}} \\ &= 2.96 * 10^{17} [\text{m}^3] , \end{aligned}$$

becomes

$$\frac{a}{3.15 * 10^7 * 70} * 2.96 * 10^{17} * 10^{-8} * \frac{2}{365} * 500 = \frac{10000}{70 * a} .$$

Solving for a, one finds a = 6.23, and therefore,

$$P_D^O = \frac{a}{70} = 0.09 \left[ \frac{1}{\text{yr}} \right] .$$

Considering, instead, 20 reprocessing facilities, the accident probability is allowed to be larger as the related inventories are smaller; the calculation gives

$$a' = 27.9 ,$$

and therefore

$$P_D^{O'} = 0.4 \left[ \frac{1}{\text{yr}} \right] .$$

Again, the resulting values for  $P_D^O$  and  $P_D^{O'}$  are unrealistically high. In order to determine the expected population dose rate  $BM'$  from each of the reprocessing plants, equation (3-6) is used in the following form

$$\begin{aligned} BM' &= P_D^{O'} * C * \frac{d}{3.15 * 10^7} * 0.5 * J_A^{air} \\ &= \frac{0.4}{3.15 * 10^7} * \frac{2.96 * 10^{17}}{20} * \frac{2}{365} * 0.5 * 0.277 * 10^{-3} \\ &= 143 \left[ \frac{\text{manrem}}{\text{yr}} \right] . \end{aligned}$$

The population dose rate from all reprocessing plants together is therefore

$$BM = 20 * BM' = 2.86 * 10^3 \left[ \frac{\text{manrem}}{\text{yr}} \right] ,$$

and

$$BM/BM_O = 7.15 * 10^{-5} .$$

#### 5.4 Liquid Waste Storage Facility Accidents

Almost any high-level waste management scheme involves an interim storage of the wastes in liquid form. Accidents could arise due to the following circumstances:

- tank corrosion,
- loss of cooling,
- hydrogen explosion,
- external causes (e.g. earthquake, sabotage, flood etc.).

It is assumed that the most severe accident is a permanent loss of cooling in the tank. In such an accident the semi-volatile radionuclides and a fraction of the remaining fission products could be released to the atmosphere. The following assumptions are made:

- a) The liquid wastes are stored for 5 years between fuel reprocessing and waste solidification;



- b) In the event of an accident all of the semi-volatile radionuclides and 5% of the remaining fission products are released over a time period of roughly 300 h (12 days);
- c) The tolerable individual dose due to a single tank accident is 2 rem over 70 years (see Section 5.3);
- d) The population density in the vicinity is the same as that for the reprocessing plant;
- e) One m<sup>3</sup> of liquid waste is to be stored for each ton of fuel reprocessed.

According to a) and e), the total storage inventory  $A_W^{FBR}$  and  $A_W^{HTGR}$ , respectively, is given by

$$A_W^{FBR} = 1.807 * 10^4 * 5 * 1 = 9.05 * 10^4$$

$$\left[ \frac{t}{yr} \right] \quad [yr] \left[ \frac{m_W^3}{t} \right] \quad \left[ m_W^3 \right] ,$$

$$A_W^{HTGR} = 1.01 * 10^4 * 5 * 1 = 5.05 * 10^4 .$$

The summation of the dilution volumes for these radionuclides at the midpoint of the total liquid waste storage period (2.5 yr) is performed with the help of the ORIGEN computer code [5-9] and gives

$$\sum_i \frac{C_i}{MPC_i} / FBR = 1.48 * 10^{15} \left[ \frac{m^3}{m_W^3} \right]$$

$$\sum_i \frac{C_i}{MPC_i} / HTGR = 4.4 * 10^{14} \left[ \frac{m^3}{m_W^3} \right] .$$

If one assumes for the moment that there exists only one liquid waste storage, then equation (3-1) reads as follows:

$$P_D^O * \left[ \sum_i \frac{C_i}{MPC_i} / FBR * A_W^{FBR} + \sum_i \frac{C_i}{MPC_i} / HTGR * A_W^{HTGR} \right] * s * \frac{d}{365} * 500 = \frac{2000}{70}$$

$$\left[ \frac{1}{sec} \right] \quad \left[ m^3 \right] \quad \left[ \frac{sec}{m^3} \right] \left[ \frac{d}{d} \right] \left[ \frac{mrem}{yr} \right] \left[ \frac{mrem}{yr} \right]$$

This gives

$$P_D^O = 1.1 * 10^{-12} \left[ \frac{1}{\text{sec}} \right] = 3.5 * 10^{-5} \left[ \frac{1}{\text{yr}} \right] .$$

Recalling that a total of 20 reprocessing sites, each with 7 liquid storage tanks, was assumed, the size of such tanks is

$$(9.05 * 10^4 + 5.05 * 10^4) / 140 = 1000 \left[ \frac{\text{m}^3}{\text{W}} \right] .$$

Therefore, the probability per year and tank must be limited to

$$P_D^{O'} = 4.9 * 10^{-3} \left[ \frac{1}{\text{yr}} \right] .$$

To determine the expected population dose rate  $BM'$  from a single liquid waste storage tank, one has

$$\begin{aligned} BM' &= \frac{4.9 * 10^{-3}}{3.15 * 10^7} * 1.12 * 10^{18} * \frac{12}{365} * 0.5 * 0.277 * 10^{-3} \\ &= 8 * 10^2 \left[ \frac{\text{manrem}}{\text{yr}} \right] . \end{aligned}$$

The population dose rate from all intermediate liquid waste storage tanks together is

$$BM = 140 BM' = 1.12 * 10^5 \left[ \frac{\text{manrem}}{\text{yr}} \right] ,$$

which means

$$BM/BM_O = 2.8 * 10^{-3} .$$

### 5.5 Waste Solidification Facility Accidents

Due to difficulties of making appropriate assumptions concerning commercial waste solidification facilities, no numerical example is given here. However, it would be strictly

parallel to the case of fabrication and intermediate liquid waste storage.

### 5.6 Transportation Accidents

Here, the emphasis is only on the transportation of spent fuel elements. The following assumptions are made:

- a) According to Ref. [5-10] the expected accidental release C of radioactivity is less than 100 Ci per accident;
- b) As Kr 85 is the most hazardous material in this connection, an accident is considered whereby all of the radioactivity released is Kr 85;
- c) For Europe (see Ref. [5-11]), about 3 severe accidents per  $10^5$  transports have been reported. The accident rate is therefore  $P = 3 * 10^{-5}$ ;
- d) It is assumed that one transport consists of 1 t of spent fuel. Therefore, the transport frequency T is given by

$$T = \frac{28,170}{3.15 * 10^7} = 8.93 * 10^{-4} \left[ \frac{\text{transp}}{\text{sec}} \right] ;$$

- e) The radionuclide atmospheric dispersion factor in the event of a transportation accident is assumed to be  $s = 10^{-6} \left[ \frac{\text{sec}}{\text{m}^3} \right] ;$
- f) The people in the vicinity of the accident are exposed to the radiation for 3000 min (2.08 days).

In order to determine the individual dose rate it is assumed that all accidents occur at the same place. Then the individual dose rate, according to equation (3-1), is given by

$$T * P * C * \frac{d}{3.15 * 10^7} * s * \frac{1}{\text{MPC}} * 500$$

$$\left[ \frac{\text{transp}}{\text{sec}} \right] \left[ \frac{\text{acc}}{\text{transp}} \right] \left[ \frac{\text{Ci}}{\text{acc}} \right] \left[ \frac{\text{sec}}{\text{sec}} \right] \left[ \frac{\text{sec}}{\text{m}^3} \right] \left[ \frac{\text{m}^3}{\text{Ci}} \right] \left[ \frac{\text{mrem}}{\text{yr}} \right] .$$

This gives an individual dose rate of

$$8.93 * 10^4 * 3 * 10^{-5} * 100 * \frac{2.08}{3.65} * 10^{16} * 10^5 * 500$$
$$= 0.763 * 10^{-8} \left[ \frac{\text{mrem}}{\text{yr}} \right] ,$$

which means that doses due to such accidents are negligible compared to the other radiation exposure possibilities, and more so if one takes into account that the accidents are not likely to occur in the same place.

A separate aspect is, nevertheless, the problem of contaminations and disturbances that would accompany such accidents. These are not considered in the methodology presented here.

References for Chapter 5

- [5-1] F.R. Farmer  
Siting Criteria - A New Approach  
Paper SM-89/34, IAEA Symposium Containment and Siting,  
Vienna (April 1967)
- [5-2] C. Starr and M.A. Greenfield et al.  
Public Health Risks of Thermal Power Plants  
UCLA-ENG-7242 (May 1972)
- [5-3] Reactor Safety Study. An Assessment of Accident  
Risks in U.S. Commercial Nuclear Power Plants.  
WASH-1400, DRAFT REPORT (August 1974)
- [5-4] Reliability. Special Issue on State of Reliability  
Effort in Europe, Guest Editor: Dr. Guenter G. Weber  
IEEE Transactions (August 1974)
- [5-5] Recommendation of the Arbeitskreis III/7 "Strahlen-  
schutztechnik" of the Deutsche Atomkommission on  
"Dosisrichtwerte bei aussergewöhnlicher Bestrahlung"  
(November 1967)
- [5-6] J.J. di Nunno et al.  
Calculation of Distance Factors for Power and Test  
Reactor Sites  
TID-14844 (1962)
- [5-7] W. Schikarski  
Überlegungen zu schweren Reaktorunfällen  
KFK 530 (1966)
- [5-8] W. Häfele  
Hypotheticality and the New Challenges: The Pathfinder  
Role of Nuclear Energy  
Minerva, Vol. X, No. 3 (July 1974)
- [5-9] M.J. Bell  
"ORIGEN-The ORNL Isotope Generation and Depletion Code"  
ORNL-4628 (1973)
- [5-10] Public Health Risks of Thermal Power Plants, Appendix  
V: Transportation of Nuclear Fuel  
UCLA-ENG 7242 (May 1972)  
Table II.5.24
- [5-11] Examination of the IAEA Regulations for the Safe  
Transport of Radioactive Materials  
EUR 3485 e,f.

## 6. Final Waste Storage Facility Accident

At present, various concepts for the final disposal of radioactive waste are being discussed: geologic, seabed, ice sheet and extraterrestrial disposal (see, e.g. Ref. [6-1] and [6-2]). It seems to be impossible at the moment to decide what concept is the most promising for the future.

The final waste storage concept referred to in this paper is that of solidified waste in a salt deposit. Only the high-level wastes are considered here. The solidified wastes are assumed to be in the form of cylinders 20 cm in diameter and stacked to a final length of 40 m. The waste will represent approximately 25% by volume of the cylinders, resulting in about 80 liters of cylinder per ton of fuel originally reprocessed.

The most easily conceivable accident in the waste storage would be flooding of the storage facility with a continued in- and out-flux of water. The release of radioactive material from the waste cylinders would be a release to the water through leaching. Almost every radionuclide is present in the radioactivity wastes. The composition of the wastes, per ton of originally spent fuel, have been calculated with the ORIGEN computer code [6-3] at the Karlsruhe Nuclear Research Center [6-4], and independently by Wild [6-5]. In Figs. 6-1 and 6-2 the time dependence of the specific dilution volumes

$$\sum_i \frac{Q_i}{MPC_w^i} \left[ \frac{m^3}{t} \right]$$

are shown for both the FBR and HTGR.

If the waste storage facility is loaded at a constant rate the total radioactivity in the facility reaches an equilibrium as shown in Fig. 6-3. This occurs after approximately 800 years. One must realize, however, that this is not a true equilibrium as the actinides have long half lives but contribute only a small portion to the total value.

FIGURE 6.1 SUMMARY OF HAZARD INDEX COMPONENTS FROM AN FBR-1000 MWe (WASTES FROM 1 METRIC TON OF CORE AND BLANKET MIXED PROPORTIONALLY AT 34000 MWD/T)

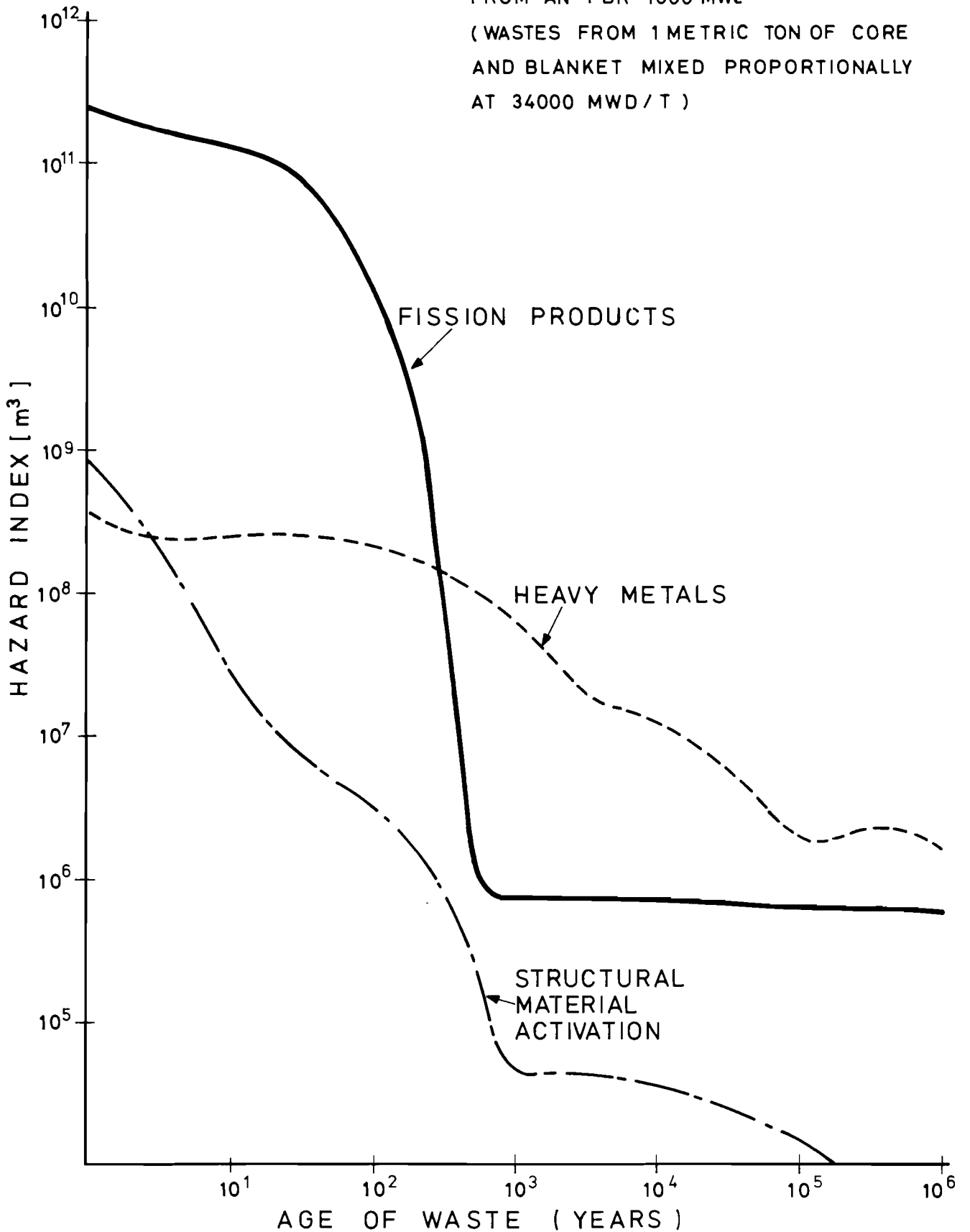

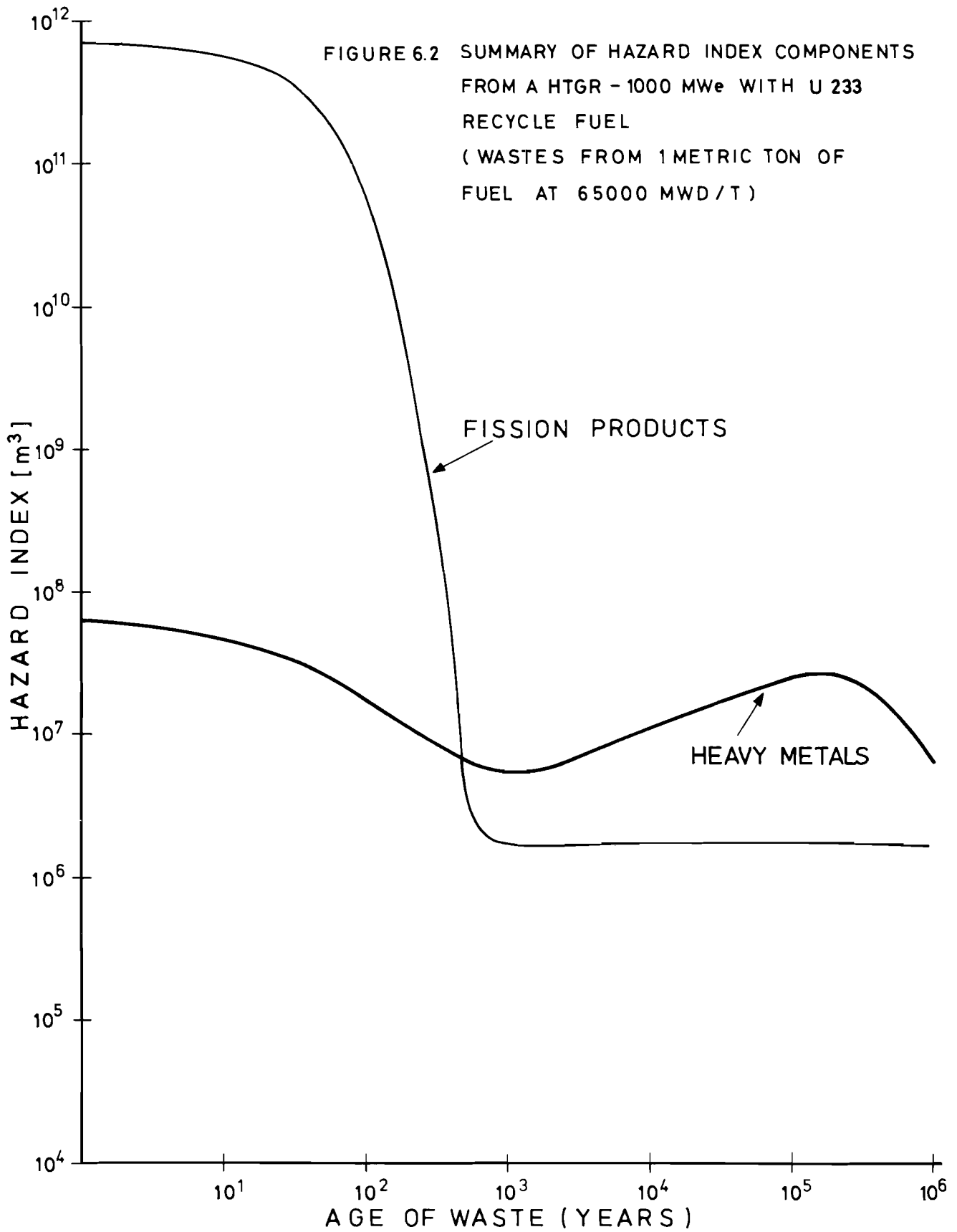
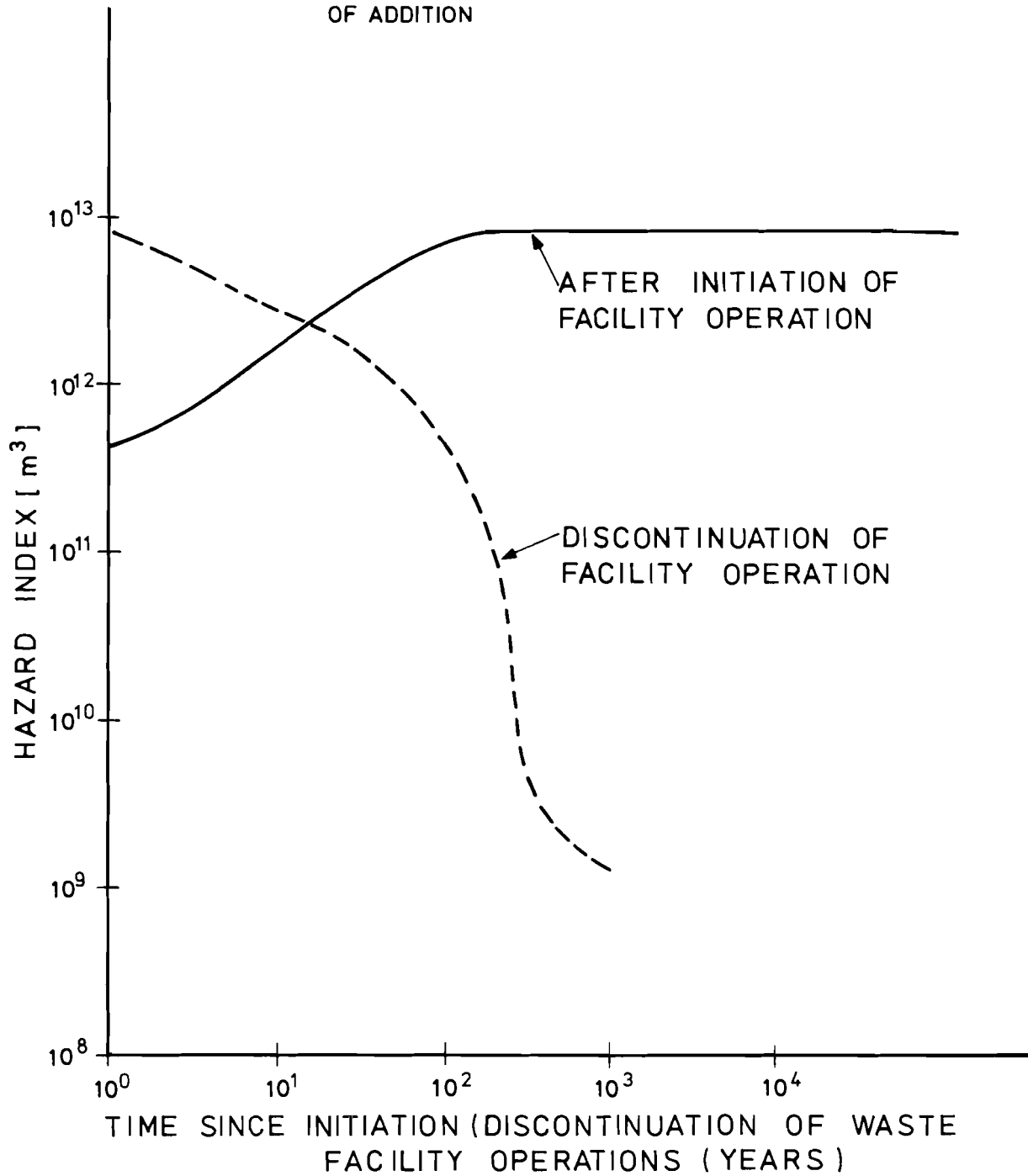



FIGURE 6.3 HAZARD INDEX OF TOTAL WASTE STORAGE FACILITY AT A CONSTANT YEARLY RATE ( $HI(t) = 4.14 \times 10^{11} m^3$ , CORRESPONDING TO THE WASTE FROM 1 METRIC TON OF SPENT FUEL REPROCESSED) OF ADDITION



It should also be noted that 95% of the equilibrium value is reached after 190 years. The equilibrium value is about 21 times the value of the yearly addition.

Let  $t = 0$  be the time when the waste is solidified. Then at  $t = 0$

$$\sum_i \frac{Q_i}{MPC_W} /_{FBR} = 1.38 * 10^{11} \left[ \frac{m^3}{t} \right] \quad (6-1a)$$

$$\sum_i \frac{Q_i}{MPC_W} /_{HTGR} = 6.29 * 10^{11} \left[ \frac{m^3}{t} \right] , \quad (6-1b)$$

where the index  $w$  refers to water. With the yearly fuel throughputs

$$A_{FBR} = 1.1 * 10^4 \left[ \frac{t}{yr} \right] \quad (6-2a)$$

$$A_{HTGR} = 1.6 * 10^4 \left[ \frac{t}{yr} \right] , \quad (6-2b)$$

the total water dilution volume at equilibrium is

$$\left[ \sum_i \frac{Q_i}{MPC_i} /_{FBR} * A_{FBR} + \sum_i \frac{Q_i}{MPC_i} /_{HTGR} * A_{HTGR} \right] * 21 = 1.86 * 10^{17} \left[ m^3 \right] . \quad (6-3)$$

The leach rates measured for various types of solidified wastes range typically from  $10^{-4}$  to  $10^{-7}$  [ $g/cm^2 * day$ ], (see Ref. [6-6]). If the worst of these values is used, one obtains a leach rate of  $1.16 * 10^{-9}$  [ $g/cm^2 * sec$ ].

It was mentioned above that there are 80 liters of waste per ton of fuel reprocessed. For a long cylinder of  $D = 20$  [cm] diameter the surface-to-volume ratio is  $\frac{4}{D} = 20$  [ $m^{-1}$ ]. One has, therefore, a surface  $S$  [ $m^2/t_{fuel}$ ] of

$$S = 80 * 10^{-3} * 20 = 1.6 \left[ \frac{m^2}{t} \right] , \quad (6-4)$$

and the fraction leached per unit time is

$$f_W = 1.16 * 10^{-9} * 1.6 * 10^4 * 10^{-6} = 1.85 * 10^{-11} \quad (6-5)$$

$$\left[ \frac{\text{g}}{\text{cm}^2 * \text{sec}} \right] \quad \left[ \frac{\text{cm}^2}{\text{t}} \right] \quad \left[ \frac{\text{t}}{\text{g}} \right] \quad \left[ \frac{1}{\text{sec}} \right] .$$

It is further assumed that only a fraction  $F_1$  of the total surface of all glass cylinders is exposed to water. Therefore,  $F_1 * f_W$  is the leach rate referring to the entire waste storage facility. One should realize, however, that once the leaching process has started it may continue indefinitely if not abated by appropriate means.

It is assumed that these appropriate means require 10 years to become effective. Within this period a finite amount of radioactivity will have been released, resulting in a population dose. As a worst case it is considered that there is an accumulation of the released radioactivity through water recycling, and therefore an accumulation of the dose with time. It is thus necessary to integrate a presumably linear build-up with time. It is assumed that there is a filtering effect in the soil through which the water is circulating and which retains a fraction  $F_2$  of the radionuclides released.

This model of groundwater recycling is crude and somewhat arbitrary, as the factors  $F_1$  and  $F_2$  are not further specified. It is used only because the methodological aspect of normative accident probabilities is one of the points of this paper. In each actual case, however, a model that reflects the prevailing circumstances of the situation must be established.

If it is assumed for the moment that there is only one final waste storage, equation (3-1) gives

$$P_D^O * F_1 * F_2 * f_W * \frac{T}{2} * \frac{Q}{\text{MPC}} * s * 500 = \frac{25000}{70} , \quad (6-6)$$

where the factor  $\frac{1}{2}$  at  $T$  accounts for the average value during the time where the radioactivity builds up.

With  $s = 10^{-1} \left[ \frac{\text{sec}}{\text{m}^3} \right]$  (see Appendix 2), one obtains

$$P_D^O * F_1 * F_2 = 1.32 * 10^{-14} \left[ \frac{1}{\text{sec}} \right] \hat{=} 4.15 * 10^{-7} \left[ \frac{1}{\text{yr}} \right] . \quad (6-7)$$

In the model society it was assumed that there were 10 final waste storage facilities. Therefore, for the single waste storage

$$P_D^{O'} * F_1 * F_2 = 1.32 * 10^{-13} \left[ \frac{1}{\text{sec}} \right] \hat{=} 4.15 * 10^{-6} \left[ \frac{1}{\text{yr}} \right] . \quad (6-8)$$

For the purpose of illustration, if one assumes  $F_1 * F_2 = 10^{-3}$ ,  $P_D^{O'}$  is calculated to be  $P_D^{O'} = 4 * 10^{-3} \left[ \frac{1}{\text{yr}} \right]$ .

For the population dose rate one finds for each of the 10 storage facilities

$$BM' = P_D^{O'} * F_1 * F_2 * f_W * \frac{T}{2} * \frac{Q}{MPC} * 0.5 * J_A^{\text{groundwater}} ,$$

which gives, with the population density integral value (3-7b),

$$BM' = 6.08 * 10^5 \left[ \frac{\text{manrem}}{\text{yr}} \right] , \quad (6-9)$$

and for the entire society,

$$BM = 10 * BM' = 6.08 * 10^6 \left[ \frac{\text{manrem}}{\text{yr}} \right] , \quad (6-10)$$

$$BM/BM_O = 0.15 .$$

References for Chapter 6

- [6-1] Overview of High-Level Radioactive Waste Management Studies,  
Battelle Pacific Northwest Laboratories Report BNWL-1758, Richland, Wash., August 1973
- [6-2] High-Level Radioactive Waste Management Alternatives, USAEC Report WASH-1297, Wash., D.C., May 1974
- [6-3] See Ref. [5-9]
- [6-4] P.E. McGrath  
Radioactive Waste Management Potentials and Hazards from a Risk Point of View  
KFK 1992 (June 1974)
- [6-5] H. Wild  
Radioaktive Inventare und deren zeitlicher Verlauf nach Abschalten des Reaktors  
KFK 1797 (Februar 1974)
- [6-6] K.J. Schneider  
Solidification and Disposal of High-Level Radioactive Waste in the United States,  
Reactor Technology, Vol. 13, 387-415 (1971)

## 7. Theft of Fissile Material and Destruction of Nuclear Facilities

### 7.1 Classification

Two sorts of risks will be considered here:

- i) Theft of fissile or radioactive material by a private group (see Ref. [7-1]) for the purpose of constructing a nuclear explosive device, or release of radioactive material to the environment;
- ii) Destruction of a nuclear facility as a special form of sabotage.

Diversion of nuclear material by a state government is not considered here. This falls in the domain of the IAEA international safeguards system in the context of the Non-Proliferation Treaty [7-2].

### 7.2 Theft of Fissile or Radioactive Material by a Private Group: Diversion Strategies

In the following, not all possibilities are considered, but only the most efficient ones from the point of view of the diverter. This means that the reactors can be excluded because of their heavy containment and the self-shielding effect of high-radiation environment of the fissile material.

Two possibilities have to be considered:

- i) Clandestine theft of small amounts of nuclear material,
- ii) Theft by sudden attack.

It is assumed that case i) is not possible while the material is in transport or in a waste storage facility because of the containment measures applied there; and in addition, that case ii) does not arise at a waste storage facility, as the extraction of the residual fissile material for the purpose of constructing a fission bomb would be most difficult.

Further, it can be assumed that sudden attack for the purpose of obtaining small amounts of radioactive substances for planned contaminations can be excluded, as thieves may hope to get them more easily by clandestine diversion.

As a result, with respect to the risk of release of radioactive material, there remains the possibility of clandestine diversion of Pu or U233 from the reprocessing and fabrication facilities. It is plausible to assume that diversion would take place when such nuclear materials are clean, that is, after reprocessing.

Assuming that locks of present-day design are installed, about 1 g of Pu may be taken out in a single operation. This requires a shielding of about 5 cm lead [7-3]. It is therefore assumed that 10 g Pu (or U233) may be diverted in this manner.

To construct an explosive device one would require about 1000 single diversions. Therefore this manner of obtaining fissile material for a bomb will not be considered here. Instead, an attack on a single transport, which has enough fissile material for one explosive device, is considered. The strategies considered are listed in Table 7-1.

### 7.3 Release of Radioactive Material

It is assumed that a private group has obtained a given amount of plutonium (x grams) and intends to disperse it into the atmosphere above a city of  $10^6$  inhabitants.

In Table 4-4, a typical plutonium mixture, as well as its radioactivity, is given. If one assumes that the amount x[g] of plutonium is dispersed into the atmosphere and will remain there for T = 10 days, then the application of equation (3-1), with equation (4-2), results in

$$P * x * \frac{T * 8.64 * 10^4}{3.15 * 10^7} * \sum_i \frac{C_i}{MPC_i} * s * 500 = \frac{25000}{70} \quad (7-1)$$

$$\left[ \frac{1}{\text{sec}} \right] [\text{gPu}] \quad \left[ \frac{\text{sec}}{\text{sec}} \right] \quad \left[ \frac{\text{Ci}}{\text{gPu isot}} / \frac{\text{Ci}}{\text{m}^3} \right] \left[ \frac{\text{sec}}{\text{m}^3} \right] \left[ \frac{\text{mrem}}{\text{yr}} \right] \left[ \frac{\text{mrem}}{\text{yr}} \right] .$$

Since in this case the close vicinity of the point where the dispersion takes place is the most critical one, a value of  $s = 10^{-6}$  is used here, which leads to

Table 7-1: Theft of fissile material by a private group.

|   |  | COMPONENT OF NUCLEAR FUEL CYCLE |  |  |               |  |
|---|--|---------------------------------|--|--|---------------|--|
| Purpose   | Method   | Reactor                         | Reprocessing   | Pu and U-3<br>Fabrication                                  | Waste storage | Transport                                  |
| Construction<br>of an<br>explosive<br>device        | Clandestine<br>diversion<br>in small<br>portions | -                               | -  | -  | -             | -  |
|   | Sudden<br>attack                                 | -                               | -  | -  | -             | Material<br>for one<br>explosive<br>device |
| Deliberate<br>release of<br>radioactive<br>material | Clandestine<br>diversion<br>in small<br>portions | -                               | PuO <sub>2</sub> or UO <sub>2</sub><br>in amounts<br>of 1g | PuO <sub>2</sub> or UO <sub>2</sub><br>in amounts<br>of 1g | -             | -  |
|   | Sudden<br>attack                                 | -                               | -  | -  | -             | -  |



$$P * x = 4.41 * 10^{-7} \left[ \frac{\text{gPu}}{\text{sec}} \right] = 13.9 \left[ \frac{\text{gPu}}{\text{yr}} \right] .$$

This means, for example, that for  $x = 5 \text{ kg}$  the limiting value would be  $P = 0.28 * 10^{-3} \left[ \frac{1}{\text{yr}} \right]$  .

The population dose rate is given by

$$\text{BM} = P * x * \frac{T * 8.64 * 10^4}{3.15 * 10^7} * \sum_i \frac{C_i}{\text{MPC}_i} * 0.5 * J_C^{\text{air}} ,$$

which gives

$$\text{BM} = 1.29 * 10^4 \left[ \frac{\text{manrem}}{\text{yr}} \right]$$

or

$$\text{BM}/\text{BM}_0 = 3.23 * 10^{-4} .$$

One may consider the case where the plutonium is dispersed in the drinking-water supply of the city. The dose rate would then be even smaller as the ratios of the corresponding MPC's of water and air are much smaller than those of the amounts of water and air consumed by the average man during the same period of time.

#### 7.4 Destruction of a Nuclear Facility

Consideration is given only to a fuel fabrication facility, as until now such facilities, contrary to reactors and reprocessing facilities, have no heavy concrete containment structures. The calculations will be given for a plutonium plant; calculations for uranium 233 plants are similar.

Considering the intentional destruction of a plant, one obtains

$$P * x * \frac{T * 8.64 * 10^4}{3.15 * 10^7} * \sum_i \frac{C_i}{\text{MPC}_i} * s * 500 = \frac{25000}{700} ,$$

which results in

$$P * x = 1.39 * 10^3 \left[ \frac{\text{gPu}}{\text{yr}} \right] .$$

(Here one has to use  $P = \frac{a}{70}$  and  $\frac{25000}{70a}$  for quantities which would lead to  $P > \frac{1}{70}$ .)

For  $x = 500\text{g}$  this gives

$$P = 0.2 \left[ \frac{1}{\text{yr}} \right] .$$

The population dose rate is given by

$$BM = P * x * \frac{T * 8.64 * 10^4}{3.15 * 10^7} * \sum_i \frac{C_i}{\text{MPC}_i} * 0.5 * J_B^{\text{air}} ,$$

which, with the value (3-7c), gives

$$BM = 9.9 * 10^2 \left[ \frac{\text{manrem}}{\text{yr}} \right]$$

$$BM/BM_0 = 2.47 * 10^{-5} .$$

### 7.5 Construction of a Nuclear Explosive Device

In this section it is assumed that a private group (group 'X', see Ref. [7-1]) has obtained the material necessary to construct a nuclear explosive device. The following assumptions are made:

- a) An explosive device is constructed with 5.6 kg of Pu of the composition given in Table 4-4. 1% of the Pu, (56 g) is fissioned. This corresponds to 1 kiloton of TNT (see Ref. [7-4]);
- b) The device is exploded on a tower in the middle of a city. Therefore a dispersion factor of  $s = 10^{-6} \left[ \frac{\text{sec}}{\text{m}^3} \right]$  is used;
- c) The people in the vicinity of the explosion are exposed to the radiation for  $T = 300$  min;
- d) The population density in the city is  $5000 \text{ man/km}^2$ , and an environment with a radius of 10 km is considered;

- e) The dose from such an event does not exceed 25 rem over 70 years;
- f) The mechanical destruction is considerable, but is not assumed to be orders of magnitude larger than that of a conventional explosive device. It will therefore not be considered a genuine risk of the nuclear fuel cycle.

The average dilution volume, 3000 min after the explosion, is determined graphically. The value is  $3.2 * 10^{15} \text{ m}^3$ .

Let  $P = \frac{a}{70}$  be the probability [ $\text{sec}^{-1}$ ] that a device will be exploded. Then from equation (3-1) one has

$$\frac{a}{70} * \sum_i \frac{C_i}{\text{MPC}_i} * \frac{T * 60}{3.15 * 10^7} * s * 500 = \frac{25000}{70.a}$$

$$\left[ \frac{1}{\text{sec}} \right] \quad \left[ \text{m}^3 \right] \quad \left[ \frac{\text{sec}}{\text{sec}} \right] \quad \left[ \frac{\text{sec}}{\text{m}^3} \right] \left[ \frac{\text{mrem}}{\text{yr}} \right] \left[ \frac{\text{mrem}}{\text{yr}} \right] .$$

This gives

$$a = 3.56 \text{ and } P = \frac{1}{20} \left[ \frac{1}{\text{yr}} \right] .$$

The population dose rate is given by

$$\text{BM} = P * \sum_i \frac{C_i}{\text{MPC}_i} * \frac{T * 60}{3.15 * 10^7} * 0.5 * J_C^{\text{air}} ,$$

which gives, with (3-7d),

$$\text{BM} = 6.22 * 10^5$$

$$\text{BM}/\text{BM}_0 = 1.56 * 10^{-2} .$$

References for Chapter 7

- [7-1] R. Lapp  
The Ultimate Blackmail  
The New York Times Magazine,  
February 4, 1973
  
- [7-2] The Structure and Content of Agreements Between  
the Agency and States Required in Connection  
with the Treaty on the Non-Proliferation of  
Nuclear Weapons  
International Atomic Energy Agency, Vienna,  
INFCIRC/153 (Corrected), June 1972
  
- [7-3] V.W. Schneider et al.  
Instruments Available for Safeguarding Fuel  
Fabrication Plants  
Karlsruhe Safeguards Symposium, Vol. I, p. 181 ff. (1970)
  
- [7-4] S. Glasstone (ed.)  
The Effects of Nuclear Weapons  
USAEC, p. 14, (1964)

## 8. Summary of Radiation Dose Rates

Table 8-1 summarizes all individual and population dose rates resulting from normal operations releases and accidental releases of radionuclides from the nuclear facilities that constitute the nuclear fuel cycle described in Chapter 2.

As already stated, the method of calculating the dose rates from normal operations releases is different from that used for accidental releases. In the first case retention factors (RF) consistent with present-day technology and practices are used. As there is no experience with respect to accident probabilities ( $P_D^0$ ) it was necessary to proceed in a different fashion. Therefore in this case a tolerable individual dose of 25 rem over a lifetime was assumed and the corresponding accident probability resulting in such a dose was calculated.

It should be mentioned, however, that our method of evaluating radiation doses is simple enough to provide new values if there are good reasons to change the retention factor or accident dose limit values. For the purpose of illustration the results are presented in the form of single values and not in the form of functional dependence as could have been done.

As the retention factors may change considerably in the next 50 years, it is difficult to draw any conclusions from the values for the normal operating release doses given in Table 8-1. It is clear that krypton 85 cannot continue to be completely released; in fact, krypton retention is being planned today. On the other hand, especially the krypton 85 figures in Table 8-1 should not be taken too literally, as there is an ongoing discussion. Some say that the conversion factor for krypton 85 is too conservative (see e.g., Ref. [8-1]), and others in fact argue for a strong reduction of the krypton 85 releases [8-2].

It is interesting to compare the ratios of the population doses resulting from accidental releases to the natural background radiation. The highest values are given by:

TABLE 8-1: SUMMARY OF RADIATION DOSE RATES

|  |                                       | NORMAL OPERATING RELEASES                          |                                   |               | ACCIDENTAL RELEASES |   |   |
|--|---------------------------------------|--|-----------------------------------|---------------|---------------------|---|---|
|  |                                       | B/Bo   | BM/BMo                            | RF            | B/Bo                | BM/BMo  | $POD' \left[ \frac{1}{YR} \right]$                        |
| REACTOR  | Kr 85 (A)                             | $1.4 \cdot 10^{-2}$ (P)<br>$5.3 \cdot 10^{-3}$ (V) | $5.3 \cdot 10^{-3}$ <sup>1)</sup> |               | $\frac{25}{8}$      | 0.09  | 0.04  |
|  | Xe 133(A)                             | $2.9 \cdot 10^{-3}$ (P)<br>$7.4 \cdot 10^{-4}$ (V) | $7.6 \cdot 10^{-4}$ <sup>1)</sup> |               |                     |   |   |
|  | H3 (A)                                | $6.3 \cdot 10^{-5}$ (P)                            | -                                 | <sup>1)</sup> |                     |   |   |
|  | H3 (W)                                | $1.4 \cdot 10^{-3}$ (V)                            | $4.5 \cdot 10^{-4}$ <sup>1)</sup> |               |                     |   |   |
| REPROCESSING<br>PLANT AND INTER-<br>MEDIATE WASTE<br>STORAGE | Kr 85 (A)                             | 0.31 (P)<br>0.24 (V)                               | 0.24                              | 1             | $\frac{25}{8}$      | REPRO:<br>$7.2 \cdot 10^{-5}$<br><br>INT.W.ST:<br>0.003 | 0.4<br><br><br><br>$5 \cdot 10^{-3}$                      |
|  | H3 (A) <sup>2)</sup>                  | $1.3 \cdot 10^{-4}$ (P)                            | -                                 | $10^2$        |                     |   |   |
|  | H3 (W) <sup>2)</sup>                  | $2.5 \cdot 10^{-3}$ (V)                            | $8 \cdot 10^{-4}$                 | $10^2$        |                     |   |   |
|  | Pu (W)                                | $2.1 \cdot 10^{-3}$ (V)                            | $6.9 \cdot 10^{-4}$               | $10^7$        |                     |   |   |
|  | U233(W)                               | $4.8 \cdot 10^{-6}$ (V)                            | $1.6 \cdot 10^{-6}$               | $10^7$        |                     |   |   |
|  | ACTINIDES(A)                          | $1.5 \cdot 10^{-3}$ (P)                            | $10^{-6}$                         | $10^8$        |                     |   |   |
| FABRICATION PLANT<br>Pu (A)                                  |                                       | $10^{-2}$ (P)                                      | $7 \cdot 10^{-6}$                 | $10^8$        | $\frac{25}{8}$      | $2.5 \cdot 10^{-5}$                                     | $POD' * X =$<br>$1.4 \cdot 10^3$ <sup>3)</sup>            |
| WASTE SOLIDIFICATION<br>EQU. Cs 137 (A)                      |                                       | $2.4 \cdot 10^{-2}$ (P)                            | $1.8 \cdot 10^{-5}$               | $10^5$        | -                   | -   | -   |
| FINAL WASTE STORAGE  |                                       | -  | -                                 | -             | $\frac{25}{8}$      | 0.15  | $POD' * F_1 * F_2 =$<br>$4.2 \cdot 10^{-6}$ <sup>4)</sup> |
| SABOTAGE AND<br>BLACKMAILING                                 | RELEASE OF<br>RADIOACTIVE<br>MATERIAL | -  | -                                 | -             | $\frac{25}{8}$      | $3.2 \cdot 10^{-4}$                                     | $POD' * X =$<br>$14$ <sup>3)</sup>                        |
|  | EXPLOSIVE<br>DEVICE                   | -  | -                                 | -             | $\frac{25}{8}$      | 0.02  | 0.05  |

Explanations for Table 8-1

- B : Individual dose rate
- $B_0$  : Individual natural background radiation dose rate
- BM : Population dose rate
- $BM_0$  : Population natural background radiation dose rate
- RF : Retention factor
- $P_D^{O'}$  : Upper limit for accident probability for one facility
- P : Point source dose rate
- V : Volume source dose rate
- 1) : Consistent with present-day technology
- 2) : Alternatively, see text Section 4.2.2
- 3) : Amount x[g] of plutonium released
- 4) : Fraction  $F_1$  of storage flooded and retention factor  $F_2$  of the soil

- a) Intermediate waste storage facility accident  
( $BM/BM_0 = 0.003$ ),
- b) Nuclear explosive device ( $BM/BM_0 = 0.02$ ),
- c) Reactor accident ( $BM/BM_0 = 0.09$ ),
- d) Final waste storage facility accident ( $BM/BM_0 = 0.15$ ).

Even if it is difficult to understand the actual values (we will come back to this question in the next chapter) one can appreciate their ordering in view of the different population densities used in each case and the following plausibility arguments:

- a) It was assumed for the explosive device that 56 g of fissionable material is fissioned;
- b) In a  $1000 \text{ MW}_e$  reactor with an inventory of 3000 kg of fissionable material, we have on the average 3000 kg fissionable material which is fissioned. If one assumes a ratio of 60 between the radioactivity of material just fissioned and that of material fissioned one year earlier (see Ref. [6-3]), and if one assumes further that on the average the fissioned material in the reactor was fissioned one year earlier, the radioactive inventory corresponds to  $3000/60 = \underline{50 \text{ kg}}$  of freshly fissioned material;
- c) In one intermediate liquid waste storage facility one has  $1000 \text{ m}^3$ , which corresponds to 1000 tons of fuel, 30 tons of which was fissioned. Assuming for the average storage content a ratio of 100 between material just fissioned and material fissioned 2.5 years earlier (see Ref. [6-3]), one obtains an inventory corresponding to 300 kg of freshly fissioned material;
- d) According to the fuel cycle data, one final waste storage facility receives 150 tons of waste per year. Furthermore, according to Chapter 6 the equilibrium radioactive inventory is about 20 times the annual input into the storage. Assuming a decay factor of 3000 between freshly fissioned material and the average waste stored, one obtains an inventory corresponding to 10 tons of freshly fissioned material.



Without further elaboration on these values of radioactive inventories, one can get an indication of where the major problems of a large scale nuclear fuel cycle are located.

References for Chapter 8

- [8-1] M.M. Hendrickson  
"The Dose From Kr 85 Released to the Earth's Atmosphere,"  
Proceedings of an IAEA/USAEC Symposium on Environmental  
Aspects of Nuclear Power Stations, New York, 1970,  
pp. 237-246
- [8-2] "Environmental Radiation Dose Commitment: An Applica-  
tion to the Nuclear Power Industry." Report of the  
U.S. Environmental Protection Agency, Wash., D.C.,  
February 1974

## 9. Policy Considerations and the Concept of Utility

### 9.1 Reactor Accidents

Before starting a new line of reasoning, let us recall the meaning of the reactor accident probability  $P_D^0$  as defined in Section 5.2 (the prime indicates that this quantity is defined for one reactor). Altogether 100 reactors are considered, 50 FBR's and 50 HTGR's. The index 0 refers to the fact that this is an upper bound, and D refers to "design" and the concept of "design basis accident" (DBA). In Section 5.2 it was also observed that one can always imagine trans design basis accidents (TDBA). Implicitly it was assumed that the probability for a TDBA is always smaller than that for a DBA, and that changes in the limiting value of probability of the DBA by appropriate technical means have an impact on the limiting value of the TDBA probability within the considered ordering.

The value of  $P_D^0$  was calculated with the help of equation (5-4) by using the concept of an individual dose rate of 25 rem in 70 years, uniformly distributed over that period. With the calculated accident probability the population dose rate  $BM'$  of a single reactor, determined by using equation (5-6), is equivalent to

$$BM' = P_D^0 * x \left[ \frac{\text{manrem}}{\text{yr}} \right] . \quad (9-1)$$

This equation can be interpreted in such a manner that an accident with a consequence of  $x$  manrem must not occur more than  $P_D^0$  times per year.

The result of the calculations was that the values for  $P_D^0$  are as high as  $10^{-2}$ , and that the population dose rates from all reactors was only 1/10 the population natural background radiation dose rate. However, it is well known that reactor accident probabilities are postulated to be smaller by many orders of magnitude. This may seem unnecessary in view of our results. It is clear that the reason for this large discrepancy is the fact that the concept of expectation values

was used: it was assumed that 25 rem uniformly distributed over 70 years is the same as 25 rem within a very short time. In addition, in the analysis in Section 5.2 it was assumed implicitly that only one type of accident is possible, namely the DBA; and that as a consequence of such an accident no person gets more than 25 rem. In reality, however, a variety of accidents of different magnitudes are possible that in the concept of expectation values, are assumed to average. Furthermore, in a specific case, a comparatively small number of people will experience very high radiation doses that can be lethal, while the same dose distributed over a large number of people causes relatively little harm. (As an example: an individual has a probability of 0.5 of dying if subject to a 500 rem dose; 1000 manrem will therefore lead to one fatality, if the number of people exposed is sufficiently small.)

The probability concept was introduced into the analysis of reactor accidents by Farmer [9-1]; the so-called Farmer curve gives the probability distribution for a reactor accident of a given consequence. Following this concept, Starr [9-2] and others have introduced the risk concept by considering the expectation value of the consequences (e.g., number of fatalities) of an accident occurring: in a discrete version, i.e., if only a finite number of accidents is possible, the expectation value  $E$  is

$$E = \sum_{i=1}^R p(x_i) * x_i \quad , \quad (9-2)$$

where  $x_i$  describes the consequences of the accident  $i$ , and  $p(x_i)$  the probability of the accident  $i$  occurring. By performing this summation, an averaging process with respect to the various types of accidents takes place: severe accidents with a small probability are taken together with accidents that are much less severe but have a much higher probability. In the extreme this leads to the result that rare but very

severe accidents are de facto eliminated from the analysis as they do not contribute significantly to the expectation value (9-2). This represents a particular difficulty of the concept, as societal perception of accidents rates one severe accident higher than the equivalent sum--in terms of consequences--of small accidents. Focussing on that difficulty, let us now consider two types of accidents: a first type with a particular manrem value which is smaller than or equal to a DBA, and a second type with a particular manrem value relating to a TDBA.

The limiting values for reactor accident probabilities are at present much smaller than those calculated in Chapter 5. For the purpose of illustration, the recently published Rasmussen Report [9-3] concludes that for Light Water Reactors the probability of a TDBA with 3000 fatalities is  $10^{-7}$  per year. If it is assumed that, as mentioned above, 1000 rem is lethal, then if rigorously pursued, this translates, within the concept of expected values, into an expected population dose rate of

$$BM = 10^{-7} * 1000 * 3000 = 0.3 \left[ \frac{\text{manrem}}{\text{yr}} \right] ,$$

which is indeed a very small number for any society.

Conceptually, this result is applied to our case in the following manner. In the Rasmussen Report 100  $\text{GW}_e$  were considered, whereas in this paper the equivalent of about 1000  $\text{GW}_e$  is considered. A total population dose rate of  $3 \left[ \frac{\text{manrem}}{\text{yr}} \right]$  for TDBA's with 3000 fatalities is thus implied by the Rasmussen analysis. This leads to an implied TDBA probability  $P$  for all reactors, which is given by

$$P * 3000 * 1000 = 3 ,$$

or  $P = 10^{-6} \left[ \frac{1}{\text{yr}} \right]$  for all reactors, i.e.,  $P' = 10^{-8} \left[ \frac{1}{\text{yr}} \right]$  for each single reactor station of the model society; which is in line

with present-day engineering practices. The contrast to the values of Chapter 5 can be further highlighted by applying equation (9-2) to the case of the two types of accidents only. This leads us to the following expectation value:

$$E = p(x_1) * x_1 + p(x_2) * x_2 \quad , \quad (9-3)$$

where index 1 refers to the first type of accident and index 2 to the second type. According to Section 5.2 one has

$$p(x_1) * x_1 = 3.5 * 10^6 \left[ \frac{\text{manrem}}{\text{yr}} \right] \quad ,$$

and furthermore,

$$p(x_2) * x_2 = 3 \left[ \frac{\text{manrem}}{\text{yr}} \right] \quad .$$

For the sake of a heuristic argument it is assumed that societal perception of accidents is such that both types of accidents are of equal concern. One manner of factoring this perception into the risk calculation is through the introduction of a utility concept according to v. Neumann and Morgenstern [9-4]. One of the authors recently participated in illustrating possible applications of this concept to the case of reactor accident analysis [9-5]. Accordingly, consider, instead of equation (9-3), the following expression:

$$U = p(x_1) * u(x_1) + p(x_2) * u(x_2) \quad , \quad (9-4)$$

where  $u(x)$  is the "utility" of the event  $x$  (society's perception of the objective event  $x$ ). It is now possible to equate these two components in equation (9-4); one obtains

$$u(x_2) = \frac{p(x_1)}{p(x_2)} * u(x_1) = \frac{10^{-2}}{10^{-8}} * u(x_1) \quad .$$

A utility ratio of  $10^6$  therefore reflects the ratio of society's perception of these different objective events. Existing techniques for evaluating utilities necessitate question and survey research of one sort or another. This results in a formalized scheme of dealing with society's perceptions and arrives at normative figures for the various probabilities in question. This kind of investigation is at present being pursued at IIASA.

## 9.2 A Decision Procedure for the Development of a Large Nuclear Fuel Cycle

This paper suggests a certain decision procedure for the deployment of a large nuclear fuel cycle if nuclear power is to be employed on a large scale. After having assessed the energy demand that is to be expected, and thereby the size of the fuel cycle in question, the following sequence of decisions or evaluations must be envisioned.

1. A regulation must be established that sets an upper limit for the individual dose rate resulting from normal operations losses and from accidental losses. So far, legally binding regulations for the individual dose rate resulting from the normal operations losses of the Light Water Reactors have been established in the U.S.A. and elsewhere. For other fuel cycle facilities or other types of reactors, similar limits have been established, but they are not yet of the same legal quality. Fixing upper limits would lead to a first assessment of the design target for the various retention factors involved. Limits for an individual dose rate resulting from accidental losses have been considered but not yet introduced as part of a formal regulation. Among other things, binding regulations would require a more advanced state of failure tree analysis, or in other words, an extension of the kind of analysis performed in the Rasmussen Report [9-3] to all kinds of nuclear facilities. Only in this case can limits for accident probabilities, which thus have a normative function, be translated into engineering measures.

Nevertheless, a formal assessment of limits to be established for the integrated individual dose over 70 years appears feasible. The value of 25 rem over 70 years is suggested in this paper.

2. In addition, a regulation must be established that restricts an upper expected population dose rate resulting from normal operating releases and accidental releases. Furthermore, governments may wish to assess constraints in terms of such population doses for regions where nuclear facilities are to be installed. A procedure analogous to that explained in this paper, but much more extensive and detailed can then be applied for site selection in each specific case.

3. On a regional basis, procedures for assessing utilities of accidental releases of radioactivity should be envisioned. This has the advantage that techniques of conflict analysis can be incorporated which involve all interest groups of the region. An example of this type of analysis has recently been given by Gros [9-6]. In fact, such techniques would give interest groups a natural function in the region in question, and could help to resolve the issue of governmental versus group interests. This would lead, for example, to limits for accident probabilities which are consistent with the views of the local interest groups. It should be realized, however, that such a procedure may change the allocated limit for the population dose; the original limit would therefore serve more as a criterion for the adequate geographical distribution of the population dose than for determining its actual limits.

The authors realize that it will take some time before such a scheme can be made operational. Failure tree analysis and procedures for assessing utilities are most in need of development. However, it should be realized that the rational deployment of a large nuclear fuel cycle also requires time. It is obvious that more work is needed if such rational deployments are to be made.



References for Chapter 9

- [9-1] See Ref. [5-1]
- [9-2] See Ref. [5-2]
- [9-3] See Ref. [5-3]
- [9-4] J. v. Neumann and O. Morgenstern  
Theory of Games and Economic Behavior,  
Princeton University Press, 1944
- [9-5] R. Papp, P.E. McGrath, L.D. Maxim, and F.X. Cook, Jr.  
A New Concept in Risk Analysis for Nuclear Facilities,  
Nuclear News, p. 63 (November 1974)
- [9-6] J. Gros  
A Paretian Approach to Power Plant Siting in New  
England,  
Ph.D. dissertation, Harvard University, 1974

## APPENDIX I

### Maximum Permissible Concentration of Radionuclides, as Recommended by the ICRP

The International Commission for Radiological Protection (ICRP) classifies all types of radiation exposure into categories as follows:

- A. Occupational exposure
- B. Exposure of special groups
  - 1) Adults who work in the vicinity of controlled areas but who are not themselves employed in work causing exposure to radiation,
  - 2) Adults who enter controlled areas occasionally in the course of their duties but who are not regarded as radiation workers,
  - 3) Members of the public living in the neighborhood of controlled areas;
- C. Exposure of the population at large.

For occupational exposure, the basic standards of permissible exposure to internal emitters\* are adopted from the values designed originally for external exposure\*\*; i.e., the dose to the gonads or the blood-forming organs during any period of 13 consecutive weeks may not exceed 3 rem, and the accumulated dose to the blood-forming organs or gonads at age N may not exceed  $5(N - 18)$  rem. The dose rate to organs other than gonads, skin, bone, and thyroid may not exceed 15 rem/year. The skin and thyroid are permitted twice this value.

---

\* Radiation arising from radionuclides within the body.

\*\* Radiation reaching the body from radionuclides external to the body.

The permissible concentrations\* of radionuclides in air or water are obtained by calculating the concentration of a given radionuclide which, if inhaled or ingested continuously, would in a lifetime exposure of 50 years result in a body burden that would deliver the maximum permissible dose to one or more organs of the body. The organ that tends to receive the highest dose, due to the metabolic properties of the radionuclide, is known as the critical organ.

The permissible levels for the internal emitters are calculated on the assumption that there is no exposure to external radiation. Where such exposure does exist, the permissible internal dose must be reduced so that the total dose to the organ from both internal and external sources does not exceed the basic value. To accomplish this, the MPC values must be reduced by the factor  $(D - E)/D$ , where D is the maximum permissible dose permitted to an organ and E is the dose received from external radiation.

Occupational exposure is not considered in the work reported in this paper. The basic radiation guide recommends that individuals who comprise groups B(a) and B(b), as given above, should not experience dose rates exceeding a whole-body or gonadal dose of 1.5 rems/year. The corresponding limit for an individual of class B(c) is set at 0.5 rems/year. If there is no external radiation, the corresponding MPC values for classes B(1) and B(2) are 0.3 of the occupational values for the 40 hr week, and for class B(3) 0.1 of the occupational values for continuous exposure, i.e. for the 168 hr week.

The continuous occupational gonadal dose rate permitted by the ICRP recommendations is 5 rem/yr. The corresponding MPC' values have been established by the ICRP for many radionuclides and all critical organs. Therefore, the ICRP tables provide

---

\*The permissible concentrations of radionuclides in air or water are labeled  $MPC_A$  or  $MPC_W$  where A is for air and W water.

the values for the conversion factor  $\rho$  defined in Chapter 3:

$$\rho = \frac{5000}{\text{MPC}'} = \frac{500}{\text{MPC}} \left[ \frac{\text{mrem}/\text{Ci}}{\text{yr}/\text{m}^3} \right] ; \quad \text{MPC}' = 10 \cdot \text{MPC} .$$

It is to be noted that the conversion factors for some important radionuclides have been calculated independently by the EPA (see Ref. [8-2]). The EPA values do not differ much from the ICRP values; therefore, for reasons of consistency, the ICRP values are used.

The level suggested by the ICRP as the maximum permissible gonadal dose to the whole population, Class C above, is a cumulative dose of 2 rem over 30 years\* apportioned between a maximum of 1.5 rem from internal emitters and 0.5 rem from external radiation. Since the continuous occupational level (168 hr/week) permits 5 rem/year \* 30 years = 150 rem in 30 years to the gonads, such a continuous occupational MPC must be multiplied by a factor of 0.01 to give an equivalent constant level of exposure. The ICRP has suggested that the same dose rate limit (1.5 rem/30 years) and reduction factor (0.01) be applied when the total body is the critical organ. In the absence of an MPC value based on the gonads, it is recommended that 0.01 of the MPC based on total body be used.

For a radionuclide, or mixture of radionuclides, which does not have the total body or the gonads as a critical organ, it is suggested that the average permissible level for large populations be  $\frac{1}{30}$  of the continuous occupational value (168 hr/week).

---

\* The average period of protection is the first 30 years, which is therefore used as the appropriate period in which the genetically significant dose is accumulated.

## APPENDIX II

### Radionuclide Transport in Air and Water

#### Transport in air

In order to determine ground level concentrations downwind from a continuous point source the following equation is commonly used (see Ref. [A2-1]):

$$\chi(x,y) = \frac{Q}{\pi \cdot \delta_y^2(x) \cdot \delta_z^2(x) \cdot U} \exp \left( - \frac{y^2}{2\delta_y^2(x)} - \frac{\bar{h}^2}{2\delta_z^2(x)} \right) ,$$

(A2-1)

where

- $\chi(x,y)$  = concentration  $\left[ \frac{Ci}{m^3} \right]$  at downwind point  $(x,y,0)$   
 $x$  = downwind distance [m]  
 $y$  = crosswind distance [m]  
 $Q$  = source strength  $\left[ \frac{Ci}{sec} \right]$   
 $\delta_y, \delta_z$  = crosswind and vertical plume standard deviations [m]  
 $U$  = mean wind speed  $\left[ \frac{m}{sec} \right]$  at the stack elevation  $h$ [m]  
 $\bar{h}$  = effective stack height  $(h + \Delta h, \text{ the plume rise})$ , [m].

Numerical values for  $\delta_y$  and  $\delta_z$  will vary according to stability conditions, wind shear, and roughness of the terrain. For practical application, values for  $\delta_y$  and  $\delta_z$  were defined by classifying stability conditions according to prevailing conditions of average wind speed and estimated radiation balance. In Fig. A.2.1 values for  $U \cdot \frac{x}{Q}$  as a function of downwind distance for a source located at a height of 30 m are given. For distances between 1 and 100 km, the value of  $U \cdot \frac{x}{Q}$  varies between  $10^{-4}$  and  $10^{-7}$ . Therefore, assuming wind

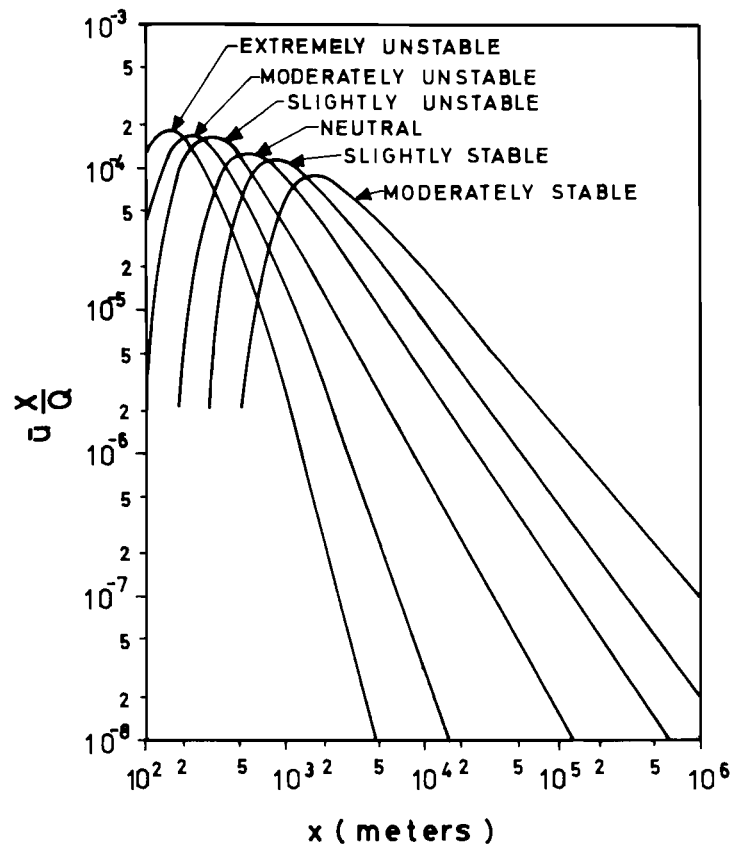

FIGURE A2.1: VALUES OF  $\bar{u} \cdot \frac{x}{Q}(x)$  AS A FUNCTION OF DOWNWIND DISTANCE  $x$  FOR A SOURCE LOCATED AT A HEIGHT OF 30 m.

speeds of 1 to 100 m/sec,  $\frac{\chi}{Q}$  varies between  $10^{-6}$  and  $10^{-9}$ . In Table A.2.1 situations which result in a dispersion factor of  $\frac{\chi}{Q} = 10^{-8}$  are given. This dispersion value is used frequently in the literature (see Ref. [A2-2] and [A2-3]), and is also used in this report except in a few cases as noted in the text.

For the purpose of determining the population doses it is necessary to account for the x-dependence of  $\chi(x,y)$ . In Ref. [A2-4], it is shown that one can assume

$$\delta_y(x) = F \cdot x^f, \quad \delta_z(x) = G \cdot x^g$$

where, depending on the meteorological conditions, f varies between 0.6 and 0.9 and g between 0.5 and 1.38. Therefore, for our purposes it is assumed that

$$\chi(x,y) \sim \frac{1}{x^2},$$

neglecting the x-dependence of  $\delta_y$  and  $\delta_z$  in the exponential function in equation (A2-1).

#### Transport in water

In shallow coastal waters the maximum concentration of a contaminant  $\chi(x)$  along the axis of the current at a distance x from a source is given by (see Ref. [A2-1])

$$\chi(x) = \frac{Q}{2D\sqrt{2\pi} \cdot K \cdot U \cdot x}, \quad (A2-2)$$

where

Q = source strength  $\left[ \frac{\text{Ci}}{\text{m}^3} \right]$

D = depth of water [m]

K = diffusivity coefficient  $\left[ \frac{\text{m}^2}{\text{sec}} \right]$

U = current velocity  $\left[ \frac{\text{m}}{\text{sec}} \right]$ .

TABLE A.2.1: DISTANCES  $x$  [KM] WHERE FOR DIFFERENT METEOROLOGICAL CONDITIONS AND DIFFERENT WIND SPEEDS A DISTRIBUTION FACTOR  $\frac{x}{Q} = 10^{-8} \left[ \frac{M^3}{SEC} \right]$  IS REALIZED.

| $\bar{u} \left[ \frac{M}{SEC} \right]$<br>METEOROLOGY | 1   | 10  | 100 |
|---|-----|-----|-----|
| A   | 7   | 4   | 2   |
| B   | 12  | 8   | 5   |
| C   | 100 | 50  | 10  |
| D   |     | 100 | 40  |
| E   |     |     | 70  |

NOTE:

- A: EXTREMELY UNSTABLE
- B: MODERATELY UNSTABLE
- C: SLIGHTLY UNSTABLE
- D:
- E: SLIGHTLY STABLE



For a depth of water of  $D = 100$  m and a diffusion coefficient  $K = 10^{-4} \left[ \frac{\text{m}^2}{\text{sec}} \right]$  the following values of  $\frac{X}{Q} \left[ \frac{\text{sec}}{\text{m}^3} \right]$  are obtained:

| $x$ [m] \ $U \left[ \frac{\text{m}}{\text{sec}} \right]$ | $10^3$            | $10^4$            | $10^5$            |
|--|-------------------|-------------------|-------------------|
| 0.1  | $2 \cdot 10^{-2}$ | $6 \cdot 10^{-3}$ | $2 \cdot 10^{-3}$ |
| 1  | $6 \cdot 10^{-3}$ | $2 \cdot 10^{-3}$ | $6 \cdot 10^{-4}$ |

Therefore, in the following the value  $\frac{X}{Q}(x) = 10^{-2}$  will be used.

For groundwater, one can assume a depth of 10 m and a speed of 0.1 m/sec. Therefore, a value of  $10^{-1}$  will be used.

References for Appendix 2

- [A2-1] Merril Eisenbud  
Environmental Radioactivity  
Academic Press 1973
  
- [A2-2] John L. Russell and Floyd L. Galpin  
A Review of Measured and Estimated Offsite Doses  
at Fuel Reprocessing Plants  
Proceedings of a IAEA/NEA/OECD-Symposium on Manage-  
ment of Radioactive Wastes from Fuel Reprocessing  
Paris 1972
  
- [A2-3] Siting of Fuel Reprocessing Plants and Waste  
Management Facilities  
ORNL-4451 (1970)
  
- [A2-4] Werner Klug  
Ein Verfahren zur Bestimmung der Ausbreitungsbedingungen  
aus synoptischen Beobachtungen  
Staub-Reinh. Luft 29, p. 143-147 (1969)