

Systems Analysis Applied to Hot Strip Production

Cheliustkin, A.

**IIASA Research Report
December 1975**



Cheliustkin, A. (1975) Systems Analysis Applied to Hot Strip Production. IIASA Research Report. Copyright © December 1975 by the author(s). <http://pure.iiasa.ac.at/215/> All rights reserved. Permission to make digital or hard copies of all or part of this work for personal or classroom use is granted without fee provided that copies are not made or distributed for profit or commercial advantage. All copies must bear this notice and the full citation on the first page. For other purposes, to republish, to post on servers or to redistribute to lists, permission must be sought by contacting repository@iiasa.ac.at

SYSTEMS ANALYSIS APPLIED TO HOT STRIP PRODUCTION*

A. Cheliustkin

December 1975

Research Reports are publications reporting on the work of the author. Any views or conclusions are those of the author, and do not necessarily reflect those of IIASA.

*Prepared in collaboration with the Moscow Institute of Control Sciences



Preface

The hot strip mill is one of the most complicated and costly installations of modern steel works. The higher the productivity of such a mill, the lower is the production cost of rolled strips. To increase productivity, there is a tendency to increase the slab weight and rolling speed. But, as is shown in this paper, certain technological limitations, although not obvious, must be considered in the design of the mill's computer control and technological equipment, since they influence productivity in various ways, depending on their combinations.

Systems analysis should be used to estimate how these combinations influence production quality and efficiency, and what design requirements should be formulated.

This paper is an attempt to apply systems analysis to the formulation of problems, and to the generation of new methods for overcoming technological limitations, in order to obtain better quality strips and higher productivity in the hot strip mill. Most of the new ideas and methods of mill control described here have not been implemented or even tried in practice; however, computer simulations of the proposed rolling process, using new control methods, are shown to lead to significantly increased efficiency.

It is obvious that future investigations in this direction should be made, and the authors hope that this will be done through the international collaboration of different institutions and steel companies, with IIASA acting as coordinator and catalyst.

Most of the work connected with the present research and the preparation of this paper was done by the staff of the Institute of Control Sciences, USSR: Drs. J. Massalsky, T. Koinov, and D. Dobronravov, and engineers A. Tropkina and A. Genkin, under the guidance of Prof. A. Cheliustkin.

Table of Contents

	page
Preface	iii
1. Introduction.....	1
2. Definition of Criteria.....	2
3. Economic Aspects of the Mathematical Model of the Process.....	3
4. Hot Strip Rolling Technique: General Problems.....	12
4.1 Strip Quality vs. High Rolling Speed.....	12
4.2 Types of Rolling Speed Patterns.....	13
4.3 Problem Differentiation with Respect to Thin and Thick Strips.....	15
5. Optimization of Strip Rolling Conditions.....	17
5.1 Determination of Optimal Temperature and Thickness of Metal to be Rolled.....	17
5.1.1 Optimal Temperature-Deformation Pattern for Thin Strip Rolling.....	17
5.1.2 Optimal Temperature-Deformation Pattern for Thick Strip Rolling.....	22
a. Metal Heating in Furnaces.....	22
b. Roughed Slab Thickness.....	26
c. Slab Thickness.....	28
5.1.3 Conclusions.....	33
5.2 Control of Various Strip Rolling Conditions.....	34
5.3 Induction Heating of Metal Entering the Finishing Stands.....	41
5.4 Inter-Stand Forced Strip Cooling.....	44
5.4.1 Problem Statement.....	44
5.4.2 Mathematical Model of Strip Inter-Stand Cooling by Water Spraying.....	46
5.4.3 A Mathematical Model of the Strip Cooling Installation.....	48

	page
6. Control of Strip Shape and Flatness.....	52
6.1 The Problems.....	52
6.2 Problem Statement.....	54
6.3 Technological Base for Problem Solution.....	55
6.4 Solution Procedure.....	66
6.5 Computation Results.....	72
Conclusion.....	75
Figures.....	76
References.....	109

1. Introduction

Continuous casting machines (CCM), combined via the slab yard with hot strip mills (HSM), make up the modern installation of the steel industry. With an annual capacity of up to 10,000,000 tons, they represent the most expensive part of the steel plant (up to 50% of total investments). Moreover, the annual operating expenses are almost equal to the cost of the complex mechanical and electrical equipment. The fixed part of these operating expenses (which does not depend on the production level) is about 50 to 60% of the total production cost; thus the higher the production, the less do the fixed expenses influence production cost [21].

The above figures show the importance of process control, since minor disturbances or improperly coordinated operations result in great economic losses. The various CCM-HSM units--the continuous casting machines themselves, heating devices, the roughing and finishing trains of hot strip mills, etc.--are, as a rule, investigated independently.

It is usually considered that the input of each unit of a steel plant is the output of the previous units, and that each unit is optimized according to its own criteria. This naturally leads to contradictions when the various parts of the process are evaluated. This problem can be resolved only with the help of a systems approach to operation analysis, based on the criteria which characterize the complex as a whole. In this study, the main principles of the systems approach to steel plant and strip production control are considered in terms of the technological and organizational interaction of the various units [9, 11, 12]. Investigation of a 2000 HSM served as the basis for determining the operational efficiency of such hot mills.

For analysis of the CCM system, the following parameters were used, taken from the readings of measuring instruments and from

the documentation: frequency of slab discharge from furnaces; fuel consumption and temperature of heated slabs; loads of the roughing and finishing processes and their drives; speed of metal movement on the rolling tables; metal speed at the exit of the finishing train; temperatures at the exit of the roughing train and at the entry and exit of the finishing train; size and thickness of the roughed slab; production cost of various kinds of strip; CCM and HSM investment cost, and so forth.

Study of the prototype mill and the principles underlying its control, as well as computer simulation, have revealed discrepancies between the control objectives of individual technological processes and the overall objective for the complex.

This paper considers the principles used for CCM-HSM complex control systems which allow coordination of the operation of the various units within the framework of the general objective: production of strips of the desired quality with the highest possible efficiency.

2. Definition of Criteria

The general criterion in optimal control of a complicated plant is a functional of the form $F(\Omega, W)$, where Ω represents the working and environmental conditions, and W is the economic status of the plant. Ω does not yield to complete mathematical description and manifests itself as a number of constraints imposed on process parameters and machinery behavior. The economic status of a mill may be described by a set of somewhat contradictory interrelated indices, such as productivity, return on funds invested, profitability, profits, etc. Each index is a functional of the type:

$$P = P(Z, K \leftrightarrow S, N \leftrightarrow Q \leftrightarrow R) , \quad (2.1)$$

where

- Z = specific investments;
- R = operating expenses;
- K,S = quality of production and price;
- N,Q = reliability of equipment and productivity.

The indication $(K \leftrightarrow S)$ means that the price of the product cannot be fully expressed through its quality. Also, equipment productivity has some relation to its reliability and its operating expenses, but this cannot be expressed as a function. In practice, for a complex manufacturing process for a given product, the relation $(K \leftrightarrow S)$ can be replaced by a set of constraints representing the necessity of obtaining a product of a certain quality. For the HSM, for example, the relation between strip metal structure (quality) and mill productivity can be replaced by the constraint of the metal rolling finishing temperature. Thus, production cost S represents a criterion of CCM-HSM operation reflecting changes in any of the production conditions. The cost is the sum of fixed expenses R_{const} including investment depreciation, and part of the variable expenses R_{var} ; i.e., the optimality criterion may be written as follows

$$\min(R_{const} + R_{var}) \quad . \quad (2.2)$$

3. Economic Aspects of the Mathematical Model of the Process

The mathematical model describes, in economic terms, the major quantitative relations involved in hot strip rolling. Under given technological constraints, the problem is reduced to determining an operational mode for the complex resulting in the minimum value of the functional (total expenditures)

$$\min R = \min R(\Delta R_f, \Delta R_t, \Delta R_r, \Delta R_u, \Delta R_d, \Delta R_y, \Delta R_a) \quad , \quad (3.1)$$

where

- ΔR_f = change in specific metal losses due to scaling;
- ΔR_t = change in furnace fuel consumption;
- ΔR_r = change in roll wear;
- ΔR_u = change in electric power consumption;
- ΔR_d = change in percentage of fixed expenses of HSM;
- ΔR_y = change in percentage of fixed expenses of CCM;
- ΔR_a = change in metal waste during shearing.

Metal heating in the furnace is described in terms of furnace temperature, average mass temperature, and metal surface temperature. The dynamics of the average mass temperature is described by a conventional differential first-order equation with non-linear temperature-dependent coefficients. Metal heating is calculated for high-speed mill operation. Under a constant temperature gradient over the slab cross-section, the average mass temperature of the metal at the furnace exit is varied. Scaling losses are described by a differential equation relating scaling growth rate to metal surface temperature, considering the initial estimate of scale layer and the furnace atmosphere. (Ref. [6] describes a method of representing experimental data on metal oxidation as a differential equation.) Experimental data on mild carbon steel oxidation were approximated by a differential equation used to determine the scaling during heating in the furnace:

$$M(T_{sl}) = 1,82 \cdot 10^{-4} T_{sl}^2 - 0,352 T_{sl} + 173,6 \frac{kr^2}{ton} . \quad (3.2)$$

The value of (3.2) per ton of metal can then be determined in monetary units through the following formula:

$$\Delta R_f = \left[M(T_{sl_1}) I_1 / m_1 - M(T_{sl_2}) I_2 / m_2 \right] C_f \frac{rub}{ton} \quad (3.3)$$

where I, m are slab surface (m^2) and mass (ton), respectively. Index 1 identifies parameters corresponding to the actual operation mode of a given mill; index 2 is associated with an

operation mode computed for this mill. C_f , the monetary losses per ton of scale, is defined by the following sum:

$$C_f = A_1 + A_2 - A_3 \quad , \quad (3.4)$$

where A_1, A_2 and A_3 are the cost of slabs coming from the CCM, slab heating in furnaces, and scale (used in steel-making plants), respectively, in roubles per ton.

Furnace fuel consumption is determined on the basis of the heat balance condition for the furnace. Results obtained were approximated by the following relation:

$$R_t = 504,6(0,25 \cdot 10^{-3}H_{sl} + 0,525)(0,705 \cdot 10^{-3}T_{sl} - 0,32) \frac{nm^3}{ton} \quad . \quad (3.5)$$

Then the value of the fuel consumption change ΔR_t can be determined through the equation

$$\Delta R_t = (R_{t2}/R_{t1} - 1)C_{t1} \frac{rub}{ton} \quad , \quad (3.6)$$

where C_{t1} is the fuel cost (roubles/ton).

Rolling was simulated by means of a mathematical model [103, 123, 154, 160] which was extended to the entire rolling mill, from slabs leaving the furnace to strips leaving the finishing train. The dependence of the maximal allowable slab temperature $T_{sl \min}$ on slab thickness H_{sl} and width B_{sl} , and on thickness H_p of the metal entering the finishing stands, under constraints on the stand loads and motor torques of the roughing train, was approximated as follows:

$$T_{sl \min} = 1,5H_{sl} + 0,28B_{sl} - 5H_p + 545 \text{ } ^\circ\text{C} \quad (3.7)$$

(H_{sl}, B_{sl} and H_p are in mm).

The roll wear ΔR_r is rather difficult to determine. Absolute roll wear does not lend itself readily to analytical description because it depends on many factors which in practice cannot be taken into consideration. Allowable relative wear depends on the mill stand number, thickness and width of the rolled strip, the relation between roll wear in various stands and metal reduction values, factors defining stability of strip shape vs. coefficient of friction, etc.

Statistical models are being constructed which allow for the dependence of roll wear on some variables under the existing operating schedule [158], but they are not applicable to a wide range of temperatures or to metal reduction and rolling speed changes.

The present paper assumes a rather simple technique for computing roll wear. Roll wear is taken to be proportional to \tilde{B} , which is equal to the sum of the products of the length of one ton of strip, L , and the mean value of roll load, P_f , in each stand:

$$\tilde{B} = \sum_{i=1}^n L_i P_{fi} \quad , \quad (3.8)$$

where n is the number of stands in a mill.

(This technique is used to determine the roll replacement time at the KIMITSU hot strip mill in Japan, where a computer summarizes the values of $L_i P_{fi}$ during rolling.) Then

$$\Delta R_r = \left(\frac{\tilde{B}_2}{\tilde{B}_1} - 1 \right) C_{r1} \frac{\text{rub}}{\text{ton}} \quad , \quad (3.9)$$

where C_{r1} is roll consumption per ton of rolled steel in roubles/ton (cost of replaced rolls related to one ton of rolled strips).

Electric power consumption is expressed as follows:

$$R_u = \gamma_u S_u \frac{\text{rub}}{\text{ton}} , \quad (3.10)$$

where γ_u is the consumption per ton (kwh/ton) determined through the rolling model, and S_u is the price of electric power (roubles/kwh).

Changes in finishing stand productivity ΔQ_h caused by changes in mill speed selection due to slab size variations are defined by the following formula:

$$Q_h = \frac{m_2 (T_{m1} + T_{p1})}{m_1 (T_{m2} + T_{p2})} - 1 , \quad (3.11)$$

where T_m and T_p are slab rolling time and slab idle time between passes, respectively.

In determining rolling time, it was assumed that the finishing stand is accelerated immediately after the front edge of the strip leaves the stand, so that the required finishing rolling temperature can be obtained. Acceleration is a function of the strip thickness and can be approximated as follows:

$$q = 273 \cdot 10^{-3} h + 0,0164 \frac{m}{s^2} ,$$

Temperature and speed of rolling influence not only the power parameters of rolling and related roll consumption, but also the mill idle time caused by roll replacements A_u . At present idle time is quite high, running from 10 to 15% of mill operation time, because replacement rolls must be heated. The total change of finishing stand productivity (with allowance for rolling speed change, duration of pauses between passes, and roll replacement) is determined as follows.

The productivity Q_2 , which takes account of the increase in roll consumption, is related to the known productivity Q_1 :

$$\frac{Q_2}{Q_1} = \frac{G_2(T_1 + T_{r1})}{G_1(T_2 + T_{r2})} ; \quad T = T_m + T_p , \quad (3.12)$$

where T_m, T_p and T_r are the strip rolling time, the pauses between rolling two slabs, and the time needed for roll replacement respectively; and G is the weight of metal rolled during this time interval T . By monitoring, the new value of G when T changes can be found to be

$$G_2 = G_1 \frac{T_2}{T_1} . \quad (3.13)$$

By substituting (3.13) and (3.12), we obtain

$$\frac{Q_2}{Q_1} = \frac{T_1 + T_2}{T_1 + (T_1/T_2)T_r} \quad (3.14)$$

with roll consumption proportional to \tilde{B} , i.e. $\frac{T_1}{T_2} = \frac{\tilde{B}_2}{\tilde{B}_1}$.

Denoting $\frac{T_2}{T_1}$ by A_4 we obtain

$$\frac{Q_2}{Q_1} = \frac{1 + A_4}{1 + A_4 \tilde{B}_2 / \tilde{B}_1} \quad (3.15)$$

Equation (3.15) reflects only the effect of roll wear on productivity. The total change in productivity is determined by considering the influence of rolling speed on the following formula:

$$\Delta Q_{\Sigma} = [1 + A_4 / (1 + A_4 \tilde{B}_2 / \tilde{B}_1)] (1 + \Delta Q_h) - 1 . \quad (3.16)$$

If the productivity change ΔQ_{Σ} is known, one can determine the change in percentage of fixed expenses for HSM per ton of product ΔR_d in the following manner:

$$\Delta R_d = [1 - 1/(1 + \Delta Q_{\Sigma})] Y_d \frac{\text{rub}}{\text{ton}} , \quad (3.17)$$

where Y_d is the percentage of fixed expenses in HSM production costs (roubles/ton):

$$Y_d = \sum_{i=1}^1 Y_{ci} \cdot A_{5i} . \quad (3.18)$$

Here Y_{ci} and A_{5i} are the values of production cost items (roubles/ton) and percentage of their fixed expenses, respectively [21], and 1 is the number of production cost items.

A decrease in slab thickness enhances slab crystallization after the slab leaves the CCM, and makes possible an increase in the linear speed of casting. But with decreasing slab thickness, other conditions being equal, the weight speed of casting (tons/hour) decreases, resulting in a decrease in "converter-CCM" cost efficiency [117]. The present paper, however, does not concern itself with operation indexes of the oxygen converter plant or problems of slab reduction (by a reduction mill installed in line with CCM [24]).

The dependence of the linear speed of casting V_y on slab size, estimated empirically, is described by the following equation [17]:

$$V_y = \frac{118(1 + B_{sl}/H_{sl})}{B_{sl}} \frac{\text{m}}{\text{min}} ; \quad (3.19)$$

the speed of casting Q_y (in tons/hour) is related to slab size by the following equation:

$$Q_y = \chi H_{sl} B_{sl} V_y \cdot 10^{-6} \frac{\text{ton}}{\text{min}} , \quad (3.20)$$

where χ is the specific weight of the cast steel (ton/m³).

The change in CCM productivity ΔQ_y due to changes in slab size is as follows:

$$\Delta Q_y = \frac{Q_{y1} - Q_{y2}}{Q_{y1}} \cdot 100\% \quad (3.21)$$

By substituting (3.19) and (3.20) in (3.21), we obtain

$$\Delta Q_y = \frac{H_{s12} + B_{s12}}{H_{s11} + B_{s12}} - 1 \quad (3.22)$$

Similarly, variations in the percentage of fixed expenses per ton of product of CCM, ΔR_y , due to variations in slab cross-section, is determined as

$$\Delta R_d = [1 - 1/(\Delta Q_y + 1)Y_y] \frac{\text{rub}}{\text{ton}} \quad (3.23)$$

where Y_y represents the fixed expenses involved in CCM production costs in roubles/ton. (Prices for equipment and production costs versus various casting conditions are given in [117].) Since the leading end of the slabs, after being rolled in the roughing stands, is cut, and assuming that the lengths of the cut-off sections are constant, the losses caused by cutting, ΔR_a , may be determined through the following formula:

$$\Delta R_a = (1 - L_{p2}/L_{p1})C_{a1} \quad (3.24)$$

where L_p is the roughed-slab length and C_{a1} is the reduction of the cost of the sheared metal ends (roubles/ton).

By analogy with C_f , C_{a1} depends on the cost of the slabs entering the HSM, the cost of heating and processing them in the roughing stands, and the cost of the scrap returned to the steelmaking plant.

Furnace productivity Q_f , under fixed slab-heating temperature and temperature gradient across the slab cross-section, is as follows:

$$Q_f = 955,3(0,67 - 0,5 \cdot 10^{-3}H_{sl})(1,73 - 0,107 \cdot 10^{-2}T_{sl}) \frac{\text{ton}}{\text{hour}} \quad (3.25)$$

The advantage of such an analytical representation of the objective function is that real data are used. These are found in every operating plant for every month and year. (Coefficients C_f , C_{t1} , C_{r1} , Y_c and Y_y , C_{a1} are taken from the processing cost tables of appropriate plants.) For the 2000 mill their factors are as follows:

$$C_f = 68 \text{ rub} \quad , \quad C_{t1} = 1,67 \frac{\text{rub}}{\text{ton}} \quad , \quad C_{r1} = 0,48 \frac{\text{rub}}{\text{ton}} \quad ,$$
$$Y_d = 6,0 \frac{\text{rub}}{\text{ton}} \quad , \quad Y_{y1} = 2,4 \frac{\text{rub}}{\text{ton}} \quad , \quad C_{a1} = 0,135 \frac{\text{rub}}{\text{ton}} \quad ,$$

The allowable load is used as a constraint at any plant of this kind. For the rolling mill, it depends on driving motor commutation and thermal states, allowable motor torques and stand loads. The dynamic load defining motor commutation conditions is especially important for the roughing stands. However, being dependent on the thermal conditions and the form of the metal leading end, it cannot be mathematically expressed. Therefore, the following procedure was adopted: several versions of rolling practiced at the 2000 mill were computer-simulated, and that with the greatest load on the roughing stands was taken as the basic one. (This turned out to be rolling of 35 x 1730 mm roughed slabs from slabs with a cross-section of 240 x 1750 mm.) In further calculations, an allowable temperature decrease was chosen so as not to exceed the motor torques and stand loads of the basic version.

4. Hot Strip Rolling Technique: General Problems

4.1 Strip Quality vs. High Rolling Speed

Rolling on today's continuous HSM faces two major problems: production of high quality metal strip and increased operation efficiency.

The quality of hot rolled metal depends on the physical-mechanical properties and the geometry of the strip (shape, gage, and flatness). The former, defined by the structure of the metal formed during rolling, determine the properties after cold or hot deformation [65,112]. The structure of the hot rolled strip also determines whether it can be used directly for deep stretch elongation [1,51].

Technological progress in rolling leads to larger mill sizes and to an increase in cost and power requirements. In such an environment, coordinated operation of individual units can greatly influence efficiency of the mill as a whole. Solutions to these coordination problems are made much more difficult because individual unit operations are often in conflict. As a rule, improvement in one aspect of the HSM operation, relative to a single criterion, leads to a deterioration in some other aspect.

It is known [160], for instance, that moderate acceleration rates ($.005-.08 \text{ m/sec}^2$) of the finishing stands stabilize the final rolling temperature T_{fd} along the strip--one of the major technological requirements--and the stand load, making rolling easier and providing the required strip shape. However, with such a rolling pattern, the speed is only 30 to 40% of the mill top speed for a strip of 1.2 - 3.0 mm, and 40 to 80% for thicker strips. Significant acceleration of the finishing stands, resulting in higher productivity, is not allowed, since the temperature of the strip tail end rises dramatically, leading to non-uniformity of the microstructure and hence adversely affecting the physical-mechanical properties along the strip [12].

Rolling mill equipment characteristics and rolling conditions require that the strip head end be rolled at low speed. As a result, when a thin strip is rolled, the finishing rolling temperature T_{fd} of the head end is below that required. To increase this temperature, it was suggested [110] that the metal temperature at the roughing train exit be increased. Indeed, an increase of strip temperature in the roughing train would result in an increase of the T_{fd} of the head end at the finishing train exit. However, this would also entail an increase of the T_{fd} of the tail end, requiring a decrease in mill acceleration (after the head end is threaded by the coiler) and thus leading to a decrease in mill productivity.

To decrease the variation in strip thickness along its length, gage control systems are used. If stand load measurements reveal a gage deflection (e.g., with changes in metal temperature), the screw-downs of the stands are driven such as to compensate for thickness changes, stand load changes increase, and the strip shape is changed. This leads to non-uniform elongation along the roll barrel and can result in the loss of strip flatness between stands and after rolling.

These factors demonstrate the need for an integrated approach to the problems of high-quality strip production and increased efficiency of HSM operation.

4.2 Types of Rolling Speed Patterns

Depending on the type of HSM automation control system, the following speed patterns are possible.

- Constant speed rolling in the finishing stand. In this case, strip metal structure and geometry may be improved by decreasing the temperature drop along the strip (Fig. 4.1), e.g., by warming the roughed-slab end on the intermediate table [104] or by forced water cooling of the metal head ends between the

finishing stands. In both cases the temperature of the entire mass of metal should be increased;

- Rolling in the finishing stand with small acceleration ($.00-.08 \text{ m/sec}^2$) to stabilize finishing rolling temperature along the strip (Fig. 4.1) and to increase mill productivity;
- Rolling in the continuous train with high acceleration rates ($0.3-1.0 \text{ m/sec}^2$) and reaching top mill speed (17-25 m/sec) after the strip is treated in the coiler. This entails an increase in finishing train productivity by 30-100% and sharp instability of the T_{fd} distribution along the strip (Fig. 4.1), and is therefore rarely used in practice [72]. Such a speed pattern, taking into account T_{fd} distribution along the strip, should be used, for example, together with forced cooling between stands [20], and with heating of only a certain length of the roughed-slab head end [15] (the end where greater T_{fd} is desired);
- Low entering speed at the first finishing stands (.4-.8 m/sec), which defines the time for metal to pass the distance between the shears and the first stand (about 20-40 sec). This time is greater than that required to move the metal along the intermediate table, thus causing extensive losses. To reduce these losses, the front end of the metal in the first finishing stands can be rolled at maximal speed, 2-3 m/sec (the associated mill output speed is 20-40 m/sec), and braking can be done at the maximal possible rate, so that the strip leaves the last stand with a speed not exceeding the permissible level (9-11 m/sec). This results in an additional increase in mill productivity of 2-4% and an increase in the T_{fd} of $10-20^\circ\text{C}$ with speed pattern 3 shown in Fig. 4.1, but results in an even greater instability of the T_{fd} along the strip.

Rolling under patterns 3 and 4 also results in instability of the stand load along the strip, thus making it more difficult to obtain good strip shape and gage.

4.3 Problem Differentiation with Respect to Thin and Thick Strips

Fig. 4.2 depicts several ways of controlling the temperature pattern of the thick strip during rolling to obtain the required metal structure.

Strips which require a finishing rolling temperature T_{fd} at the head ends can be obtained at rolling speeds lower than those allowable by the conditions of strip biting by the coiler (which we will call threading speed); these are referred to as thick strips. As may be seen from the definition, the range of thick strips depends on maximal threading speed and mill design. For a 2000 mill, strips thicker than 3.5 mm are referred to as "thick".

Diagrams of the threading speed V_b and the finishing rolling temperature vs. strip thickness, shown in Fig. 4.3, are a striking example of the difference between rolling thick and thin strips in a modern HSM. The figure gives the value of the factor K_T , the relation between slab heating temperature and finishing rolling temperature of the strip head ends, as a function of strip thickness and of the threading speeds used in the 2000 mill.

Thin strips have greater temperature drops because of the relatively large surface per mass unit. At maximum possible threading speeds (9-11 m/sec), which are limited by the coiler biting conditions and the aerodynamical phenomenon of the moving strip head end, the required T_{fd} of this end cannot be provided.

To obtain good mechanical properties of strip metal of different steel grades, the T_{fd} should be within the range of 830-920°C [23], having a tolerance of $\pm 10^\circ\text{C}$ [27,112]. In contrast, in thick strips rolling the threading speed must be reduced significantly. This increases the rolling time and thus decreases the loss of rolled metal heat.

Analyses of the present trend to use higher mill speeds and optimal rolling speed patterns result in a set of the best

possible measures for better strip metal structure (Fig. 4.1) and higher mill operation efficiency. In the figure, the more effective technological measures are shown by solid lines.

In principle, the T_{fd} of thin strips may be increased, on the one hand, by increasing the slab heating temperature in the furnaces and by roughed-slab heating on the intermediate table (for efficiency, heat should be applied only to the head end). On the other hand, the T_{fd} of the strip head end can be maintained by preventing heat losses through distribution of the metal reduction between mill stands, switching off hydraulic sprays, increasing the head end thickness of the roughed slab, and screening. When designing new mills, one can reduce the total heat losses somewhat by using a continuous roughing group.

The required level of the T_{fd} for thick strips is attained by decreasing the rolling threading speed (Fig. 4.3), by forced cooling between stands [20], by cooling the roughed slabs on the intermediate table, or by mill resetting such that the first groups of stands have a higher metal reduction rate and thus enlarging the metal radiation surface more quickly.

These measures, of course, are equally effective in both technological and economic terms. As can be seen from Fig. 4.3, it is not reasonable to vary the T_{fd} of a thin strip (1.2-2.0 mm) by varying the slab temperature, because the temperature drop along the roughed slab on the entry side of the finishing train can be reduced by as much as 8-10 times along the strip leaving the train. At the same time, the change of the T_{s1} is an effective way of influencing the T_{fd} of thick strips (8-16 mm) because the metal temperature drop of the mill is much lower (6 to 3 times).

Since the desired objective may be attained through various measures, the problem of optimal control of temperature, deformation, and rolling speed patterns becomes urgent.

5. Optimization of Strip Rolling Conditions

5.1 Determination of Optimal Temperature and Thickness of Metal to be Rolled

There are two basic points in determining metal reduction distribution in the HSM stands: the relation between the overall elongation in the roughing and finishing groups (i.e., the thickness of the slab H_{s1} and the roughed slab H_p), and the optimal metal reduction distribution between stands within the trains.

5.1.1 Optimal Temperature-Deformation Pattern for Thin Strip Rolling

The slab thickness for thin strips varies within a wide range of 180-260 mm; roughed-slab thickness is selected on the basis of the required rolled strip thickness, using the formula:

$$H_p = 5,35 h + 18,6 \text{ mm} , \quad (h \text{ in mm}) . \quad (5.1)$$

In existing practice for rolling thin strips (up to 3.5 mm), thinner roughed slabs are used to reduce stand loads. But a reduction of the H_p increases heat losses in the roughing train and on the intermediate table, as well as in the loads on the roughing stands and in the metal entering the finishing train. This temperature drop along the roughed slab (up to 2.5°C/m) leads to instability of the rolling parameters along the strip. Increased heat losses practically offset the decrease in finishing stand loads resulting from the reduction of the overall draft.

Our study includes calculation of the influence of roughed-slab thickness on T_{fd} and stand load. For the finishing stands, the overall elongation change ΔH_p , caused by the roughed-slab thickness change $\Delta \mu_\Sigma$, can be found to be:

$$\Delta \mu_\Sigma = \frac{H_p + \Delta H_p}{H_p} \quad (5.2)$$

The elongation change in each of n stands is taken to be

$$\Delta\mu_{\Sigma} = \sqrt[n]{\Delta\mu_{\Sigma}} \quad , \quad (5.3)$$

and elongation in the i -th stand is defined by the product

$$\mu_i = \Delta\mu_i \mu_i^0 \quad , \quad (5.4)$$

where μ_i^0 is the elongation in the i -th stand under the initial reduction calculated for the roughed-slab thickness H_p .

Such a distribution of metal reduction between stands, despite changes in H_p , provides uniform loading stands, which is essential so that deformation patterns meet the requirements of roll wear uniformity.

Fig. 5.1 shows the results of calculations for final rolling temperature vs. roughed-slab thickness. With increasing H_p , the temperature drop along the metal length decreases, leading to a decrease in strip gage variation [16] and in stand loads along the strip. At the same time, the acceleration must be decreased to stabilize the T_{fd} ; this is an essential disadvantage of thicker roughed slabs, leading to decreased mill productivity. For example, an increase of H_p from 27 to 40 mm when rolling a strip 1.5 x 1250 mm 1500 m long, with a threading speed of 10 m/sec, leads to a decrease in strip rolling time of 1.3%.

Table 5.1 shows the results of cost efficiency calculations for various thin strip rolling patterns. In terms of equipment capability, the rolling of thin strips has the following features: owing to low rolling speeds in the first finishing stands (0.3-1.0 m/sec) and relatively great metal reduction (45-55% in one stand), the first two stands of the 2000 mill are heavily loaded with respect to torque M_d and stand load P_d , but with only 20-30% of the main drive capacity (kw) being used. That is why Table 5.1

Table 5.1. Influence of thin strip rolling deformation pattern on cost efficiency.

$$B_{sl} = 1250 \text{ mm}, \quad T_{sl} = 1250^{\circ}\text{C}, \quad V_b = 10 \text{ m/sec}, \quad G_{sl} = 25 \text{ t}$$

$H_{sl} \times H_p \times h$ (mm)	T_V $^{\circ}\text{C}$	T_{fd} $^{\circ}\text{C}$	M_{dVI} ton·m	M_{dVII} ton·m	P_{VI} ton	P_{VII} ton	ΔR_u $10^{-2} \frac{\text{rub}}{\text{ton}}$	ΔR_r $10^{-2} \frac{\text{rub}}{\text{ton}}$	ΔR_t $10^{-2} \frac{\text{rub}}{\text{ton}}$	ΔR $10^{-2} \frac{\text{rub}}{\text{ton}}$
240 x 26 x 1.2	1101	721	141	96	1950	1900	-	-	-	-
240 x 40 x 1.2	1130	748	191	118	2060	1910	- 6.0	- 5.0	0	-13.6
300 x 40 x 1.2	1138	749	188	117	2030	1890	- 5.3	- 5.2	4.3	-19.7
300 x 45 x 1.2	1147	757	205	121	2070	1870	- 6.7	- 6.4	4.3	-22.9
300 x 50 x 1.2	1151	763	216	136	2075	1950	- 8.0	- 7.4	4.3	-25.8
350 x 45 x 1.2	1152	758	204	120	2050	1860	- 6.3	- 6.6	7.9	-27.3
240 x 28 x 1.5	1099	769	143	81	1930	1670	-10.4	- 9.7	0	-33.4
240 x 40 x 1.5	1130	794	186	94	2020	1650	-15.2	-13.6	0	-43.7
300 x 35 x 1.5	1129	786	164	90	1940	1650	-13.0	-12.5	4.3	-46.5
300 x 40 x 1.5	1138	795	183	93	1990	1620	-14.5	-13.8	4.3	-49.8
300 x 45 x 1.5	1147	804	194	104	1990	1680	-15.8	-14.9	4.3	-52.7
300 x 50 x 1.5	1151	811	205	113	2000	1720	-16.7	-15.7	4.3	-54.8

(ΔR is the charge of the processing costs)

shows the influence of deformation patterns on rolling torques (M_{dVI} and M_{dVII}) and loads (P_{dVI} and P_{dVII}) in stands VI and VII for the metal head end.

Calculations show that increased slab and roughed-slab thicknesses result in a relative reduction of heat loss and an increase in temperature at the rougher exit caused by reduced electric power consumption. Hotter metal has greater elasticity, which compensates for the influence of the relatively high metal reduction on the stand load. However, with an increase in relative reduction, the length of the deformation hearth and the arm of the resulting rolling force increase, causing increased rolling torques, though not proportional to the metal thickness.

Table 5.1 and Fig. 5.2 suggest the following conclusions.

- 1) For thin strip rolling, an increase in roughed-slab thickness of 1 mm entails an increase in T_{fd} of 1.5-2.5⁰C with virtually the same stand load. With a different reduction distribution in the finishing stands, e.g., with greater loading on the last stands, a still greater increase in T_{fd} is possible in response to changing H_{s1} and H_p .
- 2) To improve the rolled strip metal structure, it would be technologically and economically expedient to increase slab and roughed-slab thicknesses up to the complete torque load of the first finishing stands. For the 2000 mill, the optimal H_{s1} and H_p for thin strip are about 300 and 400 mm respectively, instead of the 240 and 26-35 mm used now.
- 3) The use of optimal H_{s1} and H_p makes it possible to increase the slab weight by 20-25% with the same table length, so that productivity may be increased by 3-6%. This would entail reconstruction of the coilers such as to increase the maximal coil diameter.

- 4) An increase of H_{sl} from 240 to 300 mm and of H_p from 26 to 35 mm results in a reduction by 5-7% of roll consumption caused by wear, and thus in an additional increase of mill productivity owing to reduced roll replacement time.
- 5) The economic effect of increased rough-slab thickness (disregarding the improved quality of strip structure) is a production cost decrease of about 0.4-1.0% (the thinner the strip, the greater the effect) with the same slab weight.
- 6) For newly designed mills, the thickness of roughed slabs for thin strip rolling should be selected such as to provide the required high torque load on the first finishing stands. With the same or even lower main drive kw, these drives should have greater allowable torques (say, 400 tm) in order to avoid discrepancies between mechanical and electrical equipment. This would allow reduction of the roughing train and the intermediate table lengths by a factor of 1.5.

Since the rolling speeds on the first finishing stands decrease with increasing H_p , the efficiency of the speed pattern (Fig. 4.1) becomes even greater from the standpoint of increased T_{fd} and productivity.

Since mill capability of smoothing the metal temperature drop when rolling thin strip is very high, slab temperature changes do not greatly affect the finishing rolling temperature. The load on the roughing stands depends essentially on the T_{sl} ; however, since thin strips as a rule have a width less than the maximum permitted by the mill, the roughing train is not a bottleneck with respect to load.

5.1.2 Optimal Temperature-Deformation Pattern for Thick Strip Rolling

a) Metal Heating in Furnaces

Reduction of slab temperature T_{s1} results in increased productivity of the reheating furnaces and in higher rolling speeds in the finishing train. Higher speed leads to reduced metal heat losses and to higher heat generation caused by metal deformation work [17]; thus the required finishing rolling temperature can be obtained at lower T_{s1} . Fig. 5.2 shows the threading speed vs. slab temperature for different strip and roughed-slab thicknesses.

The change in slab heating temperature T_{s1} can be used as a control action for the following reason. If at a given HSM the reheating furnaces are the bottleneck when rolling thin strips, the only way to increase operation efficiency is to enhance furnace productivity, mainly by reducing T_{s1} . This cannot be considered normal, because the cost of furnaces is only 17-30% that of the roughing and finishing trains, and furnaces should have a productivity sufficient for practically full mill loading. But in this case, the T_{s1} is also an effective control for satisfying the accepted economic criterion, since for thick strip rolling the portion of fuel in the total processing cost is 20-25%.

If T_{s1} is the same for rolling strips of different thicknesses, then to obtain the required T_{fd} when rolling thick strip, the rolling speed in the finishing train is reduced so as to increase the heat losses (Fig. 4.3); in other words, useless fuel consumption and lower mill productivity occur. For example, finishing train productivity when rolling 16.0 mm strip is 8.4% less than when rolling 5.0 mm strip, and 6.2% less for 10.0 mm strip (T_{fd} is 975°C , weight of one linear meter of the slab is 20 t, pauses between strips are 10 sec, and threading speeds are 1.7, 6.0 and 3.0 m/sec respectively).

An increased slab temperature of 10°C over the "nominal", when rolling 10 mm strip, entails decreased mill productivity owing to reduced threading speed, and thus increases the strip cost by about 0.20 roubles/ton. (Calculations were made with the following initial data: weight of one linear meter of slab = 20 tons, pauses between strips = 10 sec, threading speed = 4 m/sec.) It is interesting to note that the increased rolling speed on the finishing stands does not influence mill productivity. Thus on the last roughing stand (where rolling time is several times less than that in the finishing train), rolling speed is increased to 3.2 m/sec (there are already mills with 9.8 m/sec [57]); 14 mm strip is rolled in the finishing train at the same speed, 1.67 m/sec (for $T_{fd} = 840-850^{\circ}\text{C}$).

When rolling 8.0 x 1500 mm strips with a threading speed of 3.34 m/sec and a finishing rolling temperature of $860-870^{\circ}\text{C}$, the finishing train main drive motors are loaded to 25-30% of the rated current load. A comprehensive study of the 2000 mill finishing train has demonstrated that, for the majority of actual rolling schedules and a strip range of 1.2 to 12.0 mm, the average current load is only 50-60%, and the power load 40-50% [76]. For the strip thickness range of 4.0-16.0 mm, these values are still lower. Thus, a decrease of T_{s1} corresponds to the economic criterion and is technologically feasible, because in thick strip rolling the modern HSM has reserve strength and power.

Changes in mill finishing train productivity are shown in Fig. 5.3, with allowances for:

- rolling speed changes only (lines ΔQ_n);
- rolling speed changes plus increased time for roll replacement pauses ΔQ ;
- same as above, plus consideration of furnace productivity changes as a function of T_{s1} and strip size.

As may be seen from Fig. 5.3, the influence of roll wear on the productivity $\Delta Q_n - \Delta Q$ is an order of magnitude less than that of the slab temperature.

Figs. 5.4, 5.5 and 5.6 show consumption of electric power, rolls, and fuel, and the losses caused by scaling vs. slab temperature and strip sizes. Fig. 5.7 shows changes in the portion of fixed expenses ΔR_d and total production costs ΔR .

On the basis of the relations shown in Figs. 5.4, 5.6 and 5.7, the items of the objective function may be classified with respect to their influence on the changes in total costs ΔR with decreased T_{s1} (for the whole range of strip thicknesses) as follows:

- Decrease in the portion of fixed expenses ΔR_d ,
- Decrease in slab scaling influences ΔR_f ,
- Decrease in fuel consumption ΔR_t ,
- Increase in electric power consumption ΔR_u ,
- Increase in roll consumption (due to roll wear) ΔR_r .

The degree of influence of T_{s1} on the threading speed V_b may be characterized by a number of coefficients: the metal temperature drop smoothing along the mill, defined by the ratio of slab temperature change to finishing rolling temperature change ($K_T = \Delta T_{s1} / \Delta T_{fd}$); the finishing rolling temperature speed coefficient characterizing the ratio of T_{fd} change to that of V_b ($K_V = \Delta T_{fd} / \Delta V_b$ °C/sec/m); and the relative temperature speed coefficient ($K_{TV0} = K_{TV} / V_b$ °C).

The mill temperature/speed coefficient K_{TV} is derived from Fig. 5.2. As an average, for slab temperatures of 1100-1260°C and strip thicknesses of 5, 10, 12 and 16 mm, K_{TV} is respectively 59.3, 69.7, 72.8 and 94.2°C/sec/m. This shows that the absolute degree of slab temperature influence on rolling speed (characterized by K_{TV}) decreases with increasing strip thickness. This can be explained by the fact that with increasing strip thickness, the effectiveness of controlling finishing rolling temperature

by threading speed changes grows faster (coefficient K_V) than the metal temperature smoothing capability (coefficient K_T) decreases.

A considerable portion of the fixed expenses associated with slab heating temperature, and the strong influence of this temperature on rolling speed, fuel consumption and slab scaling, account for the sharp changes in HSM processing costs with changing heating temperature.

The influence of slab temperature decrease on mill productivity, and thus on the portion of fixed expenses ΔR_d , depends also on the initial threading speed, which is characterized by the coefficient K_{TVO} . The mean value of K_{TVO} for strips of 5, 10, 12 and 16 mm is 516, 370, 334 and 320°C respectively. The reduction of K_{TVO} (Fig. 5.7) with increasing strip thickness is attributed to the more intensive decrease of ΔR_d .

The above factors lead to the following conclusions.

- 1) The operation indexes of the furnaces, and the mill as a whole, improve with decreasing slab heating temperature until the full capacity of the mill equipment (rougher, finishing trains and coilers) is reached.
- 2) Processing costs drop sharply with decreasing T_{s1} and H_{s1} ; this effect is more pronounced for thicker strips.
- 3) Because the decrease in total costs ΔR is more intensive than the change in the portion of fixed expenses ΔR_d , a decrease of T_{s1} is profitable even disregarding the increase in mill productivity. Hence, it follows that T_{s1} is one of the most effective means for hot strip rolling control.
- 4) Savings in fuel, or (separately) a decrease of scaling losses, offset the disadvantages of decreasing T_{s1} caused by the increase in roll and electric power consumption.

The fact that, with a given slab and roughed-slab thickness, the roughing stands have a heavier load than the finishing stands is characteristic of modern hot strip rolling practice. For thicknesses of 240 and 40 mm respectively, used at the 2000 mill, the roughing stands are a bottleneck for all thick strips as far as torques and power are concerned. Formula (3.7), therefore, gives the maximum allowable T_{sl} with respect to the constraints on the roughing stand loads. To reduce these loads, a decrease in slab thickness can be proposed, which would make possible a further reduction of the slab temperature.

b) Roughed-Slab Thickness

Where the roughing stands act as the bottleneck because of their loads, the possible slab heating temperature reduction due to increased roughed-slab thickness was calculated (3.7). It was found that, given the distribution of metal reduction among the stands of both trains according to Eqs. (5.2), (5.3) and (5.4), and given the decrease of slab temperature with increased roughed-slab thickness H_p , defined by (3.7), threading speeds remained practically unchanged. With increased roughed-slab thickness, the metal is capable of preserving more heat, thus compensating for the decrease of T_{sl} (loading on the roughing stands is at the same level). Consequently, increased H_p is reasonable in the cases where:

- 1) The threading speeds are the maximum allowable (in order to save fuel and scale);
- 2) Furnaces are the bottleneck and the finishing stands are not fully loaded.

An increase in roughed-slab thickness and a reduction of T_{sl} does not significantly change roll wear rate of electric power consumption ($T_{fd} = \text{const.}$).

The optimal slab and roughed-slab temperatures vs. roughed-slab width and thickness are plotted in Fig. 5.8. For the 2000 mill, the optimal thickness H_p for a finishing rolling temperature range of 850-890°C is approximated by the formula:

$$H_{p \text{ opt}} = 35 + h \quad , \quad \text{mm} \quad , \quad (5.5)$$

and the optimal slab temperature is determined through (3.7). With such values of H_p and T_{sl} , both trains of the mill would be loaded up to about 90-95% of the allowable capacity with respect to torques and power of the main drives.

Analysis of the diagrams (Fig. 5.8) and Equation (5.5) reveals the dependence of optimal slab temperature and optimal rougher exit metal temperature T_p on strip width and thickness (Fig. 5.9).

Fig. 5.10 shows the optimal threading speeds for all thick strips associated with optimal temperature patterns (Fig. 5.9) and allowable threading speeds. The following important conclusions can be drawn from Fig. 5.10:

- 1) An appropriate temperature deformation rolling pattern, making full use of the equipment space capacity, allows an increase in mill productivity by approximately a factor of 2. This does not require large capital investments and at the same time leads to an appreciable reduction in production costs.
- 2) With reference to the optimal temperature deformation rolling pattern, narrower strips are more "profitable" than wider ones, because the width reduction results in greater productivity (t/hours, fuel and scale loss savings).
- 3) Additional possibilities for achieving higher productivity and operation efficiency in rolling wider strips include reducing the total mill draft, i.e., the slab thickness and consequently the slab heating temperature. The rolling patterns

used at the 2000 mill coincide with the optimal ones for strips 4.0-5.0 mm thick and 1800-1850 mm wide.

c) Slab Thickness

Another control action which reduces the roughing train load and thus permits reduced T_{s1} is a reduction in slab thickness. Some engineers believe that increasing the slab thickness (with length) is the technology which, by increasing the slab weight, will increase HSM productivity. But increased thickness has negative factors, such as increased fuel consumption, since slab heating increases stand loads and reduces threading speeds. Therefore, it would be useful to define optimal slab sizes for specific CCM-HSM conditions.

Table 5.2 shows the dependence of certain expenses on the production of strips with a given thickness at a constant slab temperature. These data explain the effect of slab thickness on the technical-economic indices of rolling (without possible slab temperature deduction). Note that calculations show roll wear B to be practically independent of the slab thickness with

$$T_{s1} = \text{const} , \quad T_{fd} = \text{const} , \quad H_p = \text{const} .$$

Reduction of the slab thickness (with fixed length) increases the proportion of pauses between passes and reduces the average rolling speed (with a given mill acceleration rate). On the other hand, when rolling a strip of desired thickness from a thinner slab, the metal cools faster along the mill line, and consequently the threading speeds can be increased in order to reach the desired T_{fd} . Which of these factors will be dominant depends on the mill temperature relative to the speed ratio K_{TVO} for a strip of given thickness. In the case of rolling with an acceleration rate as shown in Table 5.2, the first factor prevails and productivity decreases with H_{s1} , which is the basic reason for increased overall expenses R. When rolling strips thicker than a

Table 5.2. Cost vs. slab and strip thickness.

$$T_{sl} = 1220^{\circ}\text{C}, \quad H_p = 40 \text{ mm}, \quad T_{fd} = 886^{\circ}\text{C}.$$

h	H _{sl}	m/s	%	kop/t	kop/t	kop/t	kop/t	kop/t	kop/t
mm	mm	V _f	$\Delta Q \sum$	ΔR_u	ΔR_d	ΔR	ΔR_y	ΔR_a	ΔR_t
5.0	240	6.65	0	0	0	0	0	0	0
	220	6.80	-0.6	-0.9	2.8	4.9	2.8	2.3	-1.3
	180	7.00	-3.8	-3.7	17.0	23.0	8.6	5.1	-4.1
	168	7.05	-5.3	-4.5	23.4	30.5	10.4	6.1	-4.9
12.0	240	3.45	0	0	0	0			
	220	3.55	-2.1	-1.3	5.6	7.3	11		
	180	3.65	-9.2	-4.0	26.6	31.9			
16.0	240	2.0	0	0	0	0			
	220	2.1	-3.2	-1.4	6.5	8.2			
	180	2.2	-13.7	-4.4	29.9	34.6			

certain value at constant speed, the second factor prevails and productivity increases. Thus, in rolling strips 10 and 16 mm thick, reduction of H_{s1} from 240 to 180 mm increases productivity by 2.4% and 4.8% respectively. In this case, reduction of H_{s1} is beneficial even without reducing the slab heating temperature.

Fig. 5.2 shows the change in threading speeds with the decrease of T_{s1} for different slab and strip thicknesses; Fig. 5.11 illustrates the change in overall expenses ΔR as a function of T_{s1} with appropriate changes in slab thickness given by formula (3.7).

As follows from the data of Fig. 5.11, a reduction of both slab thickness and temperature may significantly reduce the overall expenses R . The power and torque required by the main drives for rolling strips having parameters associated with any point along the solid curves of Fig. 5.11 amounts to 90-95% of the rated values.

The distribution of reduction among stands of the roughing and finishing trains for slab, roughed-slab and strip thicknesses was computed for a 2000 mill, as shown in Formulae (5.2-5.4); as indicated above, this corresponds to uniform wear of the rolling stand rolls. The reduction distribution is shown in Tables 5.3 and 5.4.

Because of the thermal inertia of the furnace and its low speed of response, no optimal temperature for slabs of different thickness can be specified for each strip size to be rolled. Therefore, for existing CCM-HSM complexes (strip thickness 1.2-16.0 mm) at least two T_{s1} and H_{s1} steps should be introduced; thin strips should be rolled from slabs 240-300 mm thick at $T_{s1} = 1200-1250^{\circ}\text{C}$, and thick strips of low carbon steel from a slab 180-200 mm thick at $T_{s1} = 1080-1180^{\circ}\text{C}$, depending on slab width.

Table 5.3. Metal reduction in the roughing stands (slab thickness H_{sl} , thickness at the output of stands, mm).

Slab Thickness H_{sl}	I	II	III	IV	$V(H_p)$
mm	mm	mm	mm	mm	mm
240	189	139	91	57	35
240	195	144	104	64	40
240	200	156	109	72	48
240	209	168	121	84	58
220	178	132	98	62	40
180	155	121	93	60	40
168	146	116	90	59	40

Table 5.4. Metal reduction in the finishing stands (roughed slab thickness and workpiece thickness, mm).

Roughed Slab Thickness H_p mm	Stand Numbers						
	VI	VII	VIII	IX	X	XI	XII(h)
	mm	mm	mm	mm	mm	mm	mm
35.0	21.2	15.9	12.0	8.8	6.9	5.7	5.0
40.0	24.0	17.6	13.0	9.4	7.2	5.8	5.0
48.0	28.0	20.0	14.6	10.2	7.6	6.0	5.0
58.0	33.0	23.0	16.0	11.0	8.0	6.1	5.0
35.0	23.5	17.7	14.7	12.6	11.2	10.4	10.0
40.0	26.0	19.0	15.5	13.1	11.5	10.5	10.0
48.0	29.2	20.9	16.8	14.0	12.0	10.7	10.0
58.0	35.0	24.5	19.0	15.2	12.6	11.0	10.0
40.0	30.5	25.5	21.5	18.3	15.7	13.5	12.0
40.0	31.1	26.6	22.9	21.7	19.0	16.7	16.0

With modernization, the number of reheating furnace zones will be increased to 8-10 (thus, the fourth heating furnace, with walking beams, of the 2000 mill would consist of eight zones [44]). This will permit the proper heating of small lots of slabs.

5.1.3 Conclusions

Comparing electrical and gas slab heating with respect to capital investments, operating costs (chiefly electric and fuel consumption) and metal losses through scaling [2, 86, 97], we find that for most cases gas heating is more effective. This kind of efficiency analysis disregards improved controllability of rolling on the HSM, and the possibilities for obtaining the optimal temperature/speed relations for each strip size which can be achieved with electrical heating. Since the processing costs in the roughing and finishing trains and in the coilers exceed the overall costs of the CCM and the reheating furnaces, an increased operating rate of the HSM greatly influences the efficiency of the CCM-HSM complex.

When establishing optimal slab sizes for the newly constructed CCM-HSM, optimal slab thickness for a given width should be considered, so as to determine slab length (for a given slab weight) and the design (in particular, the width) of the reheating furnaces. The use of thinner and longer slabs (with the same weight) would increase the cost of a single furnace (probably approximately in proportion to the increased length). But since depreciation outlays for furnaces are much lower than fuel costs, and since decreasing slab thickness also decreases fuel consumption, the use of thinner and longer slabs will not greatly affect the economic indices of furnace operation.

Thus, for a 2000 mill, calculations show that depreciation outlays for furnaces are 0.29 roubles/ton and fuel consumption is 1.67 roubles/ton (subtracting used outgoing heat); decrease of

the slab thickness by 1 mm reduces fuel consumption by 0.425% and increases furnace width by 0.5% (with the same slab weight).

Using Formula (3.25), it is easy to see that reduction of the slab thickness from 240 to 180 mm, with a possible reduction (for mill stand loads) of slab temperature from 1220 to 1120⁰C (formula 3.7), increases furnace productivity by 22% with the same slab length (i.e., by reducing its weight). With the same weight or with increased length, the reduction of T_{sl} and H_{sl} mentioned above increases furnace productivity by 63%. Consequently, a group of five reheating furnaces, with a total site length of 135 m, can be replaced by a group of three wider furnaces with a total site length of 82 m. Note that increased slab length also improves the technical-economic indices of the CCM.

Consequently, thinner and longer slabs reduce processing costs in the HSM, and reduce capital investments in reheating furnaces, with a relatively insignificant decrease of CCM productivity.

To roll thick strips at the existing HSM, lighter slabs should be used. This can be achieved if we use thinner rather than shorter slabs wherever possible.

5.2 Control by Varying Strip Rolling Conditions

As was mentioned above, the basic problems to be solved in the hot rolling of thin strips include the increase in finishing rolling temperature of the strip head end with its stabilization along the strip length, using intensive acceleration of the mill. An additional requirement is the reduction of stand load variation along the length of the metal being rolled, which is dictated by good rolled strip shape and flatness.

This part of the paper focuses on rolling technology for a solution of these problems. One possible solution is rolling the slab on

the roughing stands while simultaneously changing the roll gaps in such a way that the head end of the roughed slab will be thicker than the tail end.

On the finishing stands, a roughed slab with varying thickness distribution along its length should be rolled such that the reduction of the head end is larger than that of the tail end. This means that the roll position of each stand should be continuously changed during rolling (except that of the last stand). The increased thickness of the head end results in lower metal deformation resistance, which, in spite of heavier metal reduction, causes almost constant stand load.

Reduced thickness of the roughed slab toward its tail end results in great heat losses and an increased temperature drop along the entire metal length entering the finishing stands. The latter may be compensated by greater acceleration of the mill, giving higher mill productivity.

Excessive total reduction in the finishing stands of the thicker metal head was distributed among the stands according to the procedure described above (formulae 5.2-5.4).

Table 5.5 shows the distribution of metal thickness on the entry side of the stands for variable roughed-slab thickness; in the denominator the values of the tail end thickness are given (in terms of existing practice).

Table 5.6 shows the results obtained from computing the finishing stand loads and speed conditions for a HSM 2000 rolling strip 1.5 x 1250 mm with the existing technology (roughed-slab thickness entering the finishing stands, 27 mm) and with the technology proposed above.

In simulation it was assumed that thickness changes linearly along the roughed-slab length. As the calculation showed, to

Table 5.5. Thickness of the head (numerator) and the tail (denominator) ends of the metal in the finishing stands (strip 1.5 x 1250 mm).

Stands Number	VI	VII	VIII	IX	X	XI	XII
Thickness, mm	<u>40.00</u>	<u>19.00</u>	<u>9.00</u>	<u>5.20</u>	<u>3.35</u>	<u>2.26</u>	<u>1.75</u>
	27.00	18.50	6.80	4.20	2.90	2.10	1.70

Table 5.6. Finishing stand load during rolling of the tail end (numerator) and the front end (denominator) of the metal. Finishing rolling temperature for the existing (version I) and proposed (version II) rolling technology. (HSM 2000, strip 1.5 x 1250 mm, length 1500 m, threading speed 10.5 m/sec).

Version	Stand Number and Stand Load, Tons						
	VI	VII	VIII	IX	X	XI	XII
I	<u>2320</u>	<u>1950</u>	<u>1360</u>	<u>1100</u>	<u>1080</u>	<u>800</u>	<u>700</u>
	770	590	325	210	160	70	30
II	<u>2000</u>	<u>1720</u>	<u>1260</u>	<u>1050</u>	<u>1010</u>	<u>770</u>	<u>7700</u>
	270	340	210	150	105	3	-25

stabilize the finishing rolling temperature along the strip thickness, the acceleration should be increased from 0.022 to 0.06 m/sec². With a slab weight of 25 tons, pauses between strips of 10 sec, and a threading speed of 10.5 m/sec, the proposed technology would increase mill productivity by more than 15%.

As can be seen from Table 5.6, in rolling thin strips from roughed slabs with the thickness increasing uniformly towards the head end, the stand load variation along the metal length is decreased; depending on the specific values of the head end thickness, the rate of increase of the last stand load towards the strip tail end can be reduced.

Instead of a linear change of the roughed-slab thickness along its length, only the head end could be made thicker to obtain the higher finishing rolling temperature of this end (Fig. 5.12 A). The metal volume of this thicker part is selected to be equal to that of the strip being rolled and to have the same length as the distance between the mill and the coiler. The increased thickness is selected to satisfy the constraints of the stand load and the main drive torque.

In the above example, calculation has shown that the thickness can be increased up to 40 mm; the increase of the finishing rolling temperature of the head end of the strip is then equal to 30°C.

After the strip enters the coiler, the mill is rapidly accelerated (Fig. 5.12 B) in order to keep the overall finishing rolling temperature at the same level as that of the head end (without acceleration this temperature would drop due to the rolling of the thin portion of the roughed slab).

The metal reduction distribution between stands, when rolling thicknesses of 40 and 27 mm, has been determined by using formulae (5.2-5.4). It was assumed that, when thinner metal enters the

finishing stands, the roll setting of these stands is performed automatically. Since the proposed method of a stepwise resetting of the finishing stands, the influence of the metal reduction distribution on finishing rolling temperature was investigated, using the mathematical model of the 1700 HSM. Results of the simulated rolling of a strip 1.5 mm thick and 1050 mm wide, with threading speeds of 7.42 m/sec, 8.5 m/sec and 10.0 m/sec, are given in Tables 5.7 and 5.8.

The figures in the second row of Table 5.7 and the third row of Table 5.8 represent a reduction distribution regularly used by the mill; the remainder show different distributions calculated taking into account stand load and main drive torque limitations. Figures 5.13 and 5.14 graphically reflect the values of Tables 5.7 and 5.8.

As can be seen from these graphs, the varying metal reduction distribution has a significant influence on the finishing rolling temperature of the strip head end (for a strip 3.0 x 1050 mm, it is about 70⁰C, and for a strip 1.8 x 1050 mm, 50-60⁰C). The results show that the finishing rolling temperature may be increased and stabilized along the strip length by:

- Increasing metal reduction in the last finishing stands, with a corresponding reduction in the first stands when rolling the head end of the metal, until the strip is threaded in the coiler; after that, the reduction distribution should be reversed in order to increase the metal heat losses and attain a higher acceleration rate;
- Combining the above mentioned method of metal reduction redistribution with rolling of the roughed slab having variable thicknesses along its length.

The proposed methods of improving finishing rolling temperature along the strip length require continuous resetting of the stand

Table 5.7. Temperature of the strip head as a function of reduction distribution among the finishing stands. (HSM 1700, strip 3.0 x 1500, rolling speed 8.85 m/sec, roughed slab thickness 37 mm).

	Absolute and Relative Reduction in Stands							Maximum Load Stand Tons	Head Part Temperature (°C)
	I	II	III	IV	V	VI	VII		
1.	37.00- -18.50 (50%)	18.50- -9.50 (48.7%)	9.50- -5.00 (47.6%)	5.00- -4.00 (20%)	4.00- -3.50 (12.5%)	3.50- -3.20 (8.6%)	3.20- -3.00 (6.2%)	1800; Stand I	836
2.	37.00- -20.80 (44%)	20.80- -11.78 (43%)	11.78- -7.55 (36%)	7.55- -5.52 (27%)	5.52- -4.52 (27%)	4.02- -3.21 (20%)	3.21- -3.00 (6.5%)	1550; Stand I	839
3.	37.00- -27.00	27.00- -20.00	20.00- -10.00	10.00- -6.50	6.50- -4.00	4.00- -3.30	3.30- -3.00	1900; Stand III	852
4.	37.00- -25.00	25.00- -20.00	20.00- -16.00	16.00- -12.00	12.00- -6.82	6.82- -3.75	3.75- -3.00	1850; Stand VI	872
5.	37.00- -30.00 (19%)	30.00- -25.00 (17%)	25.00- -20.00 (20%)	20.00- -10.00 (50%)	10.00- -6.00 (40%)	6.00- -3.75 (37.5%)	3.75- -3.00 (20%)	2150; Stand IV	873
6.	37.00- -33.00	33.00- -30.00	30.00- -27.28	27.28- -13.64	13.64- -6.82	6.82- -3.75	3.75- -3.00	2100; Stand IV	892
7.	37.00- -37.00 (0%)	37.00- -37.00 (0%)	37.00- -27.28 (26.3%)	27.28- 13.64 (50%)	13.64- -6.82 (50%)	6.82- -3.75 (45%)	3.75- -3.00 (20%)		

Table 5.8. Head part temperature as a function of reduction distribution among the finishing stands. (HSM 1700, strip 1.8 x 1050 mm, rolling speed 7.42 and 10.m/m/sec; roughed slab thickness 32 mm) .

Number of Stands	Absolute and Relative Reductions in Stands							Maximum Rolling Effort,		End of Rolling Temperature °C	
								Tons in Stands			
	I	II	III	IV	V	VI	VII	8.85 m/sec	10.0 m/sec		
1.	32.00- -16.00 (50%)	16.00- -8.00 (50%)	8.00- -4.17 (48%)	4.17- -3.10 (26%)	3.10- -2.32 (25%)	2.32- -2.00 (14%)	2.00- -1.80 (10%)	1880; Stand III	1780; Stand II	746	802
2.	32.00- -16.00 (50%)	16.00- -8.00 (50%)	8.00- -4.00 (50%)	4.00- 2.88 (28%)	2.88- 2.16 (26%)	2.16- -1.94 (7.6%)	1.94- -1.80 (7.2%)	2000; Stand III	1780; Stand II	747	803
3.	32.00- -19.30	19.30- -8.80	8.80- -5.40	5.40- -3.70	3.70- -2.50	2.50- -2.05	2.05- -1.80	1350; Stand I	2060; Stand II	753	809
4.	32.00- -26.00 (19%)	26.00- -20.00 (23%)	20.00- -9.10 (54.5%)	9.10- -6.00 (45%)	5.00- -3.00 (40%)	3.00- -2.20 (27%)	2.20- -2.80 (18%)	2400; Stand III	2300; Stand III	782	835
5.	32.00- -26.00 (12.5%)	28.00- -23.20 (17%)	23.20- -11.60 (50%)	11.60- -5.80 (50%)	5.80- -3.20 (45%)	3.20- -2.20 (32%)	2.20- -1.80 (18%)	2200; Stand IV	2060; Stand III	793	846
6.	32.00 -31.00	31.00- -29.02	29.02- -14.52	14.52- -7.27	7.27- -4.00	4.00- 2.40	2.40- -1.80	2200; Stand III	2060; Stand III	812	864

screw downs; this, in turn, requires resetting of the main drive speed regulator to match the metal elongation changes in the stands. Thus these changes should be made by automatic feed-forward control systems, which calculate rolling speed changes in the stands caused by screw-down position changes.

Although the increase in metal heat content of the strip head end, due to increasing the metal reduction in the last stands, reduces the load increase in these stands, there are still variations of the strip. To avoid these variations, the hydraulic roll bending systems should be reset in accordance with the stand load variation.

5.3 Induction Heating of Metal Entering the Finishing Stands

Because of the high metal temperature drop, the smoothing capability of the finishing train, and the large heat losses when rolling thin strips, the measures described above can prove rather ineffective for obtaining the desired level of T_{fd} (850-900°C for strips thinner than 1.8 mm).

One effective means for increasing the metal temperature is induction heating. To study the feasibility of induction heating, calculations were made for serially positioned inductors located on the intermediate roll table where switching is done simultaneously with metal motion. (Total length of the inductors is assumed to be 90 m; the metal moves along the intermediate roll table for 40 sec.) Calculation results are given in Table 5.9. The temperature is to be increased only for a portion of the metal which, after the strip leaves the mill, has a length equal to the distance from the mill to the coiler. (Therefore, for a roughed-slab thickness of 40 mm, the length is assumed to be 8250 mm, and for 50 mm, 6600 mm).

The thicker part of the metal leaving the roughing train is hotter and loses less heat while on the intermediate roll table. There-

Table 5.9. Increase of roughed-slab temperature by induction heating.

Heated Metal Portion Dimensions, mm	Output Temperature at the Roughing Train, °C	Unit Power, kW	Temperature at the Finish- ing Train Entry, °C		
			Surface	Center	Mean Mass
40 x 1250 x 8250	1120	10000	1317	1243	1280
50 x 1250 x 6600	1150	6700	1288	1220	1254

fore, the performance in terms of temperature variation along the length is better for metal having a thickness of 50 mm than one of 40 mm.

Induction heating should compensate for the natural cooling of the metal on the intermediate table and in the finishing train by a slight temperature increase of the metal tail end. Figure 5.15 represents a calculated roughed-slab temperature distribution along its length for the case of 1.5 mm strip rolling.

To decrease the heat losses of the front part of the metal, the rolling of this part is started at full speed (as shown in Figure 5.15 A) and slowed down when the head end of the strip leaves the mill. For this speed pattern the temperature of the front end of the roughed slab should be brought by induction heating to 1050°C , and then, with the rolling speed slowing down, rise to 1150°C . With mill acceleration, the roughed-slab temperature should increase until the mill top speed is reached. Calculations show that, for a strip 1.5 mm thick, the metal temperature of the roughed slab at the entry of the finishing train should be about 900°C (for a thickness of 40 mm). The practical possibility of having such low slab heating temperature depends on the capability of stands and their main drives.

For metal entering the finishing train to reach 900°C , the slab heating temperature should be reduced by $100\text{-}150^{\circ}\text{C}$. This saves fuel and metal losses through scaling. In addition, a decrease of the slab heating temperature greatly increases furnace capacity.

When rolling thick strips of 6.0-16.0 mm, an important disturbance is the non-uniformity of temperature along their lengths. This is caused by metal temperature reduction in those parts of the metal in contact with the skid rails of the furnaces. The thicker the strip, the less the temperature smoothing ability of the mill [17] and the greater this non-uniformity. To diminish this effect of the skid rails, the heating furnaces are placed askew [68].

Nevertheless, with rolling delays or unduly high speed of mill operation, the influence of skid rails on the finishing rolling temperature can be as high as 40 or 45°C, causing non-uniformity of metal properties along the strip length which can be outside the range of tolerance [36]. This is especially important for tube manufacture, ship-construction and other steel uses.

Table 5.10 gives calculated data on increasing 2000 HSM productivity by warming roughed slabs along their lengths by induction heating. As can be seen from this table, efficiency is increased with decreasing strip thickness.

It follows, then, that induction heating of the roughed slab is a technologically and economically effective means for increasing the rolling speed and stability of thin strip temperature. An engineering solution is the combination of induction heating with increased thickness of the roughed slabs, and variable redistribution of the metal reduction between finishing stands during strip rolling.

5.4 Inter-Stand Forced Strip Cooling

5.4.1 Problem Statement

Once the strip is threaded into the coiler, the mill is accelerated to increase and stabilize the finishing rolling temperature along the strip length. However, the acceleration needed for that purpose proves to be very small (0.005-0.08 m/sec²); as a result, the average rolling speed is considerably below the mill capacity.

Increased acceleration (up to 0.5 m/sec²) leads to considerable non-uniformity in temperature distribution along the strip length [157], the finishing rolling temperature of the tail end is at least 80-100°C higher than that of the front end. This temperature difference is much above the allowable ±10-12°C.

Table 5.10. Calculated mill productivity increase by use of induction heating (slab weight 25 tons, maximal acceleration 0.5 m/sec^2 , pauses between strips 10 sec).

Dimensions	1.2 x 1250	1.5 x 1250	2.0 x 1250
Threading Speed, m/sec	10	10	9
Productivity Increase, %	59.2	53.3	44.4

To overcome the conflict in the requirements for stability of temperature along the strip length and mill productivity, forced inter-stand water cooling is used in combination with increased acceleration of the mill [70].

5.4.2 Mathematical Model of Strip Inter-Stand Cooling by Water Spraying

Analysis of mathematical models of rolled metal temperature [55, 75, 160] leads to expressions which are the core of the model proposed. The temperature variation along the strip length in the i -th inter-stand area can be expressed as follows:

$$\begin{aligned}
 T_{ai} &= \sqrt[3]{\frac{1}{3} \left[\frac{1}{3(T_i + 273)^3} + \frac{B_i}{10^8} \int_0^{L_{ai}} \frac{dl}{S(v)} \right]^{-1}} - 273 ; \\
 T_{ei} &= \sqrt[3]{\frac{1}{3} \left[\frac{1}{3(T_{ai} + 273)^3} + \frac{B'_i}{10^8} \int_{L_{ai}}^{L_{ei}} \frac{dl}{S(v)} \right]^{-1}} - (T_{ai} - D_i T_{wi}) x ; \\
 x \left\{ 1 - \exp \left[- \frac{\alpha_i^*}{3,6 D_i C_i \rho_i} \int_{L_{ai}}^{L_{ei}} \frac{dl}{S(v)} \right] \right\} &- 273 ; \quad (5.6) \\
 T'_i &= \sqrt[3]{\frac{1}{3} \left[\frac{1}{3(T_{l(i-1)} + 273)^3} + \frac{B_{i-1}}{10^8} \int_{L_{l(i-1)}}^{L_{d(i-1)}} \frac{dl}{S(v)} \right]^{-1}} - 273 ; \\
 T_i &= T'_i + K_{1i} (\sigma_i + K_{2i} \Delta \sigma_{K(i-1)}) - \frac{K_{3i}}{\sqrt{v_i}} (T'_i - T_{ri}) ;
 \end{aligned}$$

where

- $T'_i, T_i, T_{ai}, T_{ei}$ = strip temperature at the input and output of the i -th stand, and at the input and output of the forced cooling zone, respectively ($^{\circ}\text{C}$);
- T_{wi}, T_{ai} = temperature of the cooling water and average temperature of the rolls of the i -th stand, respectively ($^{\circ}\text{C}$);
- B_i, B'_i = thermal coefficients of metal over appropriate parts of the inter-stand area ($^{\circ}\text{C}/\text{hour } ^{\circ}\text{K}$);
- L_{ai}, L_{ei}, L_{di} = distance from the i -th stand to the input and the output of the cooling area, and length of the inter-stand area, respectively (m);
- $S(v) = h_i v_i$ = relative (per unit strip width) metal flow within the stand (mm x m/s);
- h_i, v_i = strip thickness (mm) and metal linear speed at the output of the i -th stand (m/sec), respectively;
- ρ_i, C_i = density (kg/m^3) and heat consumption capacity of the metal ($\text{kcal}/\text{kg}^{\circ}\text{C}$), respectively;
- D_i = coefficient of mass;
- α_i^* = strip-to-water heat transfer coefficient ($\text{kcal}/\text{m}^2, \text{hour}^{\circ}\text{C}$);
- l = length (m);

- $K_{1i} - K_{3i}$ = coefficients which depend on the strip reduction conditions and the steel grade;
- σ_i = metal resistance to deformation at specific temperature and speed conditions (kg/mm^2);
- $\Delta\sigma_{Ki}$ = residual strain metal hardening (kg/mm^2).

The parameters of the model (5.6) were updated from the experimental data [148], and good agreement of calculated and experimental data was obtained. Analysis of the data reported in [41, 77] and those obtained by experiments has led to characteristics which are approximated by the relations [41, 77]:

in area

$$\begin{aligned} 0 \leq C_m \leq 32 & & (5.7) \\ \alpha^* = 44C_m & ; \end{aligned}$$

in area

$$\begin{aligned} 32 \leq C_m \leq 100 & & (5.8) \\ \alpha^* = 44C_m - 3,66(C_m - 32)^{\frac{3}{2}} & , \end{aligned}$$

where C_m is a specific water flow.

Figure 5.16 shows T_{fd} variations along the length of strips of different widths; the curves were obtained in the experiments and with the mathematical model (5.6).

5.4.3 A Mathematical Model of the Strip Cooling Installation

A mathematical model for control of the cooling units should supply the control system with real-time values of heat transfer coefficients needed to stabilize T_{fd} along the strip length with a given speed pattern. (Thin strip patterns will not be treated.)

Variables which influence the metal temperature during rolling in the finishing stands can be classified into three basic groups:

- 1) Input uncontrolled variables, such as roughed-slab temperature T_p at the entry to finishing train, threading speed V_b , acceleration a , maximal rolling speed V_{max} , strip thickness h ;
- 2) A controlled input variable, i.e., the heat transfer coefficient α^* ;
- 3) An output variable, i.e., the finishing rolling temperature T_{fd} .

To optimize temperature conditions through the use of forced inter-stand cooling, the method of looking up all possible versions in the mathematical model was used.

Calculations of optimal transfer coefficients for stabilizing T_{fd} along the strip length [19,20] lead to certain conclusions:

- When strips are rolled at a high acceleration rate (Figure 5.17 A), the curve of the heat transfer coefficient as a function of the strip length has the same shape as that of the finishing rolling temperature T_{fd} (calculated for rolling without forced rolling);
- Forced cooling should start when the finishing rolling temperature exceeds the required level;
- The rate of increase of the heat transfer coefficient along the strip length when accelerating, $\chi = \operatorname{tg}\rho$ (Figure 5.18), is proportional to the acceleration rate;
- When rolling speed reaches its maximal nominal rate, the value of the required heat transfer coefficient diminishes somewhat along the strip length; this is equivalent to the decrease of T_{fd} when rolling at a constant speed.

In the light of these factors, the mathematical model used to calculate the inter-stand metal cooling set-point may then be represented by an equation determining the variation of the required heat transfer coefficient along the strip length for rolling with acceleration

$$\chi = \frac{d\alpha^*}{dl} = K_{TV}(a - a_s)K_1 \quad , \quad (5.9)$$

where a_s is the calculated acceleration value which insures constant T_{fd} along the strip length without forced cooling, m/sec^2 ; K_{TV} is a coefficient which depends on the threading speed V_b , the roughed slab temperature T_p and strip thickness h ; K_1 is a coefficient which depends on the length of the forced cooling area l_{fr} in each inter-stand area $K_1 = 2/l_{fr}$.

Computations using the model (5.6) for strips 1.5-5.0 mm thick and rolling speed changes from 6.0-11.0 m/sec to 16 m/sec, with an acceleration of up to $0.5 m/sec^2$ and a roughed-slab temperature ranging from 1000 to 1100°C, show that the coefficient K_{TV} can be represented in the form

$$K_{TV} = K_0 + \frac{K_v}{V_b} - K_{tp}T_p \quad . \quad (5.10)$$

The values of the coefficients of adjustment, K_0 , of speed K_v , and of temperature, K_{tp} , were found to be a function of the strip thickness h . The function was approximated by using the method of least squares separately for the ranges 1.5-2.0 mm and 2.0-5.0 mm. For the strip 1.5-2.0 mm thick,

$$K_0 = -65,0 + 74,0 h - 16,0 h^2 \quad , \quad (5.11)$$

$$K_v = -637,427 + 916,218 h - 227,492 h^2 \quad ,$$

$$K_{tp} = (-84,296 + 100,85 h - 23,1 h^2) \cdot 10^{-3} \quad ;$$

and for the strip 2.0-5.0 mm thick,

$$K_o = 10,0 h - 1,0 \quad , \quad (5.12)$$

$$K_v = 306,25 - 28,75 h + 8,75 h^2 \quad ,$$

$$K_{tp} = (8,55 + 7,45 h + 0,25 h^2) \cdot 10^{-3} \quad .$$

The approximation error for the functions (5.11) and (5.12) is below 2.2%.

Once the maximal rolling speed is achieved, the strip finishing rolling temperature reduces somewhat, and consequently the required heat transfer coefficient is also somewhat reduced. The rate at which α^* reduces along the strip length was shown to be almost independent of the speed and practically totally dependent on the thickness of the strip:

$$\chi' = f(h)K_1 \quad . \quad (5.13)$$

Approximation of the strip thickness function $f(h)$ by using the method of least squares gives: for strips 1.5-2.0 mm thick,

$$f(h) = 2,22 - 2,46 h + 0,8 h^2 \quad ; \quad (5.14)$$

for strips 2.0-5.0 mm thick,

$$f(h) = 5,28 + 6,11\sqrt{h} - 1,42 h \quad . \quad (5.15)$$

On the basis of these equations, control algorithms have been developed. Computer simulations show that productivity of the HSM for thin strip rolling can be increased by 15-25%, and for thick strips by 30-80%.

6. Control of Strip Shape and Flatness

6.1 The Problems

Strip quality depends on such metal characteristics as physical and mechanical properties, surface condition, gage variation along the strip length, and strip shape and flatness.

Consumer requirements for hot strip quality grows continuously; this is especially true for those characteristics which affect the technical-economic indices of strip users in the industry. Major causes of geometrical parameter instability are the elastic deformation of the rolls, and their temperature instability and wear [3, 33, 37, 39, 64, 107, 113, 124, 130, 135, 137, 138].

The fundamentals of current systems for strip gage control were formulated about two decades ago by Hessenberger and Jenkins, who were the first to analyze the operation of a multi-stand mill with variations in screw-down positions and speeds of stand main drives [53]; by Courcoulas and Ham, who composed incremental equations for a five-stand mill [26] and by Lainis and Ford, who determined the "technological" coefficients of variables in these equations [79]. The theory and practice of automatic control in this field were further developed by Druzhinin, Mirer [28, 29, 31], Cheliustkin [9], Feinberg, Vydrin [35, 151], [34, 150], Meerov, Perelman and Karlik [10, 67, 87, 88, 101], Miller, Maxwell, Wallace, Hessenberg [54, 58], and others.

Methods of gage control have improved greatly since the first system was installed in the USA Geneva Steel Works HSM [76]. The best systems today reduce longitudinal variation in thickness to ± 0.05 mm over 95 to 98% of the length, but in spite of this, the strips do not meet all the requirements.

When an automatic thickness control system is in operation, the stand load varies by as much as 2.5 MN (250 tons) or 2.8 MN

(280 tons) [155], causing significant changes in strip shape and flatness due to elastic deformation variations in the rolls. Strip shape variation can be reduced by crossing longitudinal axes of work rolls or of back-up rolls with respect to the work rolls [38], by varying the pressure in cylinders of the upper roll balancing system [108], or by thermal shaping of rolls [128]. But the most widespread method is hydraulic roll bending by means of hydraulic cylinders set between the roll necks [81, 126, 133, 143, 144, 146].

Roll bending systems have a high speed of response and thus insure a good strip shape for strips of different thicknesses and widths. The back-up roll bending system permits shape control in a wide range of strips, but requires cumbersome hydraulic units and special roll types with stretched necks. To obtain the same effect as with the working roll bending system, it is necessary to use hydraulic cylinders with the ability to develop considerable force [90], which is limited by the permissible ball bearing load or bending stress on the roll pins [129].

Numerous studies [98, 128, 139, 141] have revealed that, to compensate for strip shape variations, the necessary force applied to the working roll chocks should be as large as half the stand load during rolling. As a result, the life of the working roll ball bearings is shortened. Investigations made on the 1700 HSM showed that this life is reduced from 1860 to 742 hours [45].

Before automatic systems of strip shape stabilization are developed, automatic profile and shape sensors should be made available. While certain sensors of strip shape in cold rolling mills have been designed [59, 96, 127], there are no measuring instruments to monitor the strip in the HSM. This explains why the existing roll bending systems do not operate automatically and are used only as a means for mill setting.

The state of the art in this field can be summarized as follows:

- 1) In terms of geometrical dimensions and especially flatness, the hot rolled strip does not fully meet consumer requirements;
- 2) The main component of strip shape variations is the work roll bend over the strip width (this bending line is rather accurately approximated by quadratic equations);
- 3) Non-uniformity of the gap due to thermal deformation of the roll systems is sufficiently accurately approximated by a parabolic equation;
- 4) Conventional methods used to improve the accuracy of strip gage and shape are inadequate for any dramatic improvement in hot rolled strip quality;
- 5) The longitudinal thickness and shape of a hot rolled strip cannot be stabilized simultaneously by conventional thickness control systems measuring the gap by the Sims method;
- 6) The range of hydraulic roll bending system applications is limited by the dramatic increase in bearing wear and bending stresses on the roll pins.

6.2 Problem Statement

Stabilization of strip gage thickness is achieved by use of gage controllers installed on the mill stands. When disturbances change the metal pressure on the rolls, the controllers switch on the screw-down drives and change the pressure still further; this results in changing roll bending, which in turn changes the roll gage and metal shape, which influences strip flatness.

All this suggests the need for a technique that would minimize variations in mean strip thickness and shape. The method to be

described, a refinement of that put forward in [9] by Cheliustkin, can be regarded as a way either to control strip geometry or to correct the gage controller set-points for indirect measurement of the gap between rolls.

Let a finishing train consist of N stands of which all but the last one are equipped with an automatic gage control system using data on deflection of the rolling parameters from the rated values. The optimal distribution of screw-down displacements that will minimize the deflections must be determined. The optimality criterion is then minimal error in the shape of the strip leaving the finishing train as well as in the inter-stand areas. To be more specific, the mean thickness difference at the output of the finishing train should be compensated down to zero.

6.3 Technological Base for Problem Solution

Figure 6.1 represents the upper part of the gap where L is the work roll barrel length and a is the distance between the screw-down axes.

The strip thickness difference along the strip width can be represented as a sum

$$\Delta h = \Delta h_h + \Delta h_r + 2f \quad , \quad (6.1)$$

where

Δh_h = component of stand-housing expansion and screw-down bearing compression;

Δh_r = longitudinal thickness variation component due to bend of the roll system;

$2f$ = thickness variation component caused by the strip shape.

Also,

$$\Delta h_r = 2(\Delta h_1 + \Delta h_2) \quad ,$$

where

$\Delta h_1, \Delta h_2$ = components due to roll bend measured at the left and right edges of the rolls (see Figure 6.1).

Since the roll bend curve can be approximated by a quadratic parabola, the relation of the components Δh_r and f is

$$\Delta h_r = f \left[\left(\frac{a}{B} \right)^2 - 1 \right] \quad , \quad (6.2)$$

where B is the strip width.

In the light of (6.2) and with the origin of the coordinates in the middle of the roll barrel, the thickness variation distribution along the strip width is

$$\begin{aligned} \Delta h_x &= 2 \left[0,5 \Delta h_n + f \left\{ \left(\frac{a}{B} \right)^2 - 1 \right\} + f - 4 \frac{f}{B^2} X^2 \right] = \quad (6.3) \\ &= \Delta P \left\{ \frac{1}{M_{st}} + 2 \frac{1}{C_r} \left[\left(\frac{a}{B} \right)^2 - \left(\frac{2x}{B} \right)^2 \right] \right\} \quad , \\ \Delta h_h &= \frac{P}{M_h} \quad , \end{aligned}$$

where

ΔP = full rolling load increment;

M_h = rigidity of the stand-housing with due regard for compression of the screw-down and the rolls in contact with the strip;

C_r = rigidity of the rolls, determined by the technique of [158] as

$$\frac{1}{C_r} = C_1 B^3 + C_2 B^2 + C_3 B \quad ; \quad (6.4)$$

$$C_1 = - \frac{7}{18,8 \text{ ED}^4} \quad ;$$

$$C_2 = \frac{12a}{18,8 \text{ ED}^4} \quad ;$$

$$C_3 = \frac{0,5}{\pi G D^2} \quad .$$

In (6.4)

E = Young's modulus;

G = shift deformation resistance;

D = work roll diameter.

Then the mean strip thickness variation caused by roll bend will be determined as

$$\begin{aligned} \Delta \bar{h} &= \frac{1}{B/2} \int_0^{B/2} \Delta P \left\{ \frac{1}{M_h} + 2 \frac{1}{C_r} \left[\left(\frac{a}{B} \right)^2 - L \left(\frac{x}{B} \right)^2 \right] \right\} dx = \quad (6.5) \\ &= \Delta P \left\{ \frac{1}{M_h} + 2 \frac{1}{C_r} \left[\left(\frac{a}{B} \right)^2 - \frac{2}{3} \right] \right\} = \Delta P \frac{1}{\bar{M}_{st}} \quad , \end{aligned}$$

where

\bar{M}_{st} = averaged rigidity of the roll stand with due regard for roll system bend.

Note that ΔP generally changes sign and thus determines the direction of bend deflection.

Let us consider a seven-stand continuous group (N=7). Introduce the notation:

i = ordinal number of the stand ($1 \leq i \leq N$);

$\bar{H}_i, \Delta\bar{H}_i$ = strip thickness averaged over the cross-section and thickness difference at the input to the i-th stand, respectively;

$\bar{h}_i, \Delta\bar{h}_i$ = strip thickness averaged over the cross-section and thickness difference at the output of the i-th stand, respectively;

T_i = strip temperature at the deformation site of the i-th stand of the finishing train;

ΔS_i = screw-down displacement in the i-th stand.

Then the mean thickness variation at the output of the seventh stand will be [3]

$$\Delta\bar{h}_7 = K_{H7}\Delta H_7 + K_{T7}\Delta T_7 + K_{S7}\Delta S_7 \quad ; \quad (6.6)$$

where

$$K_{T7} = \frac{\partial h_7}{\partial T_7} = \alpha'_7 \cdot \frac{P_{nom7}}{M_{st7} + M_m} \quad ; \quad (6.7)$$

$$K_{S7} = \frac{\partial h_7}{\partial S_7} = \frac{\bar{M}_{st7}}{M_{st7} + M_{m7}}$$

P_{nom7} = nominal (set-point) value of the stand load;

M_{m7} = strip rigidity modulus at the deformation site of the seventh stand;

α'_i = coefficient defining, in relative units, the stand load change vs. metal temperature change by 1°C;

α' = $\frac{\partial P}{\partial T} \cdot \frac{1}{P_{nom}}$ are taken, following reference [103], to be 0.0025.

Writing similar relations for the remaining stands (or $i = 1, 2, 3, 4, 5, 6$) we will, after appropriate transformation, have the following expression for thickness variation at the output finishing train:

$$\begin{aligned} \Delta \bar{h}_7 = & K_{H7} K_{H6} \cdots K_{H1} \Delta \bar{H}_1 + \sum_{i=1}^7 K_{H7} K_{H6} \cdots K_{Hi+1} K_{Ti} \Delta T_i + \\ & + \sum_{i=1}^7 K_{H7} K_{H6} \cdots K_{Hi+1} K_{Si} \Delta S_i . \end{aligned} \quad (6.8)$$

Let us now use a linear form of (6.8) as the optimality criterion in solving the problem. Without significant loss of accuracy, the effect of roughed-slab thickness variation $\Delta \bar{H}_1$ on $\Delta \bar{h}_7$ ($K_{H7} K_{H6} \cdots K_{F1} \ll 1$) can be neglected.

As a requirement for gage and shape control, consider ΔS_7 equal to zero; in other words, the screw-downs of the last stand are adjusted to the set-point. Non-flatness of the strip leaving the i -th stand is determined under specific rolling conditions through non-uniformity of metal elongation distribution along the roll barrel, which is generally found as

$$\Delta_i(x) = \frac{H_i \text{ nom}}{h_i \text{ nom}} - \frac{H_i \text{ nom} + \Delta P_{i-1} \left\{ \frac{1}{M_{h,i-1}} + 2 \frac{1}{l_{r,i-1}} \left[\left(\frac{a}{b} \right)^2 - \left(2 \frac{x}{b} \right)^2 \right] \right\}}{h_i \text{ nom} + \Delta P_i \left\{ \frac{1}{M_{hi}} + 2 \frac{1}{l_{ri}} \left[\left(\frac{a}{b} \right)^2 - \left(2 \frac{x}{b} \right)^2 \right] \right\}}$$

It is well known that a necessary and sufficient condition for uniformity of metal drawing along the roll barrel is the similarity of strip cross-sections at the input and output of the stand rolls. From the strip cross-sections of Figure 6.2, it is seen that, with the above hypothesis, the metal shape at both sides of the roll is similar. Overall similarity of cross-sections is observed if and only if

$$\frac{H}{h} = \frac{F}{f} = \mu = \text{const} .$$

Indeed,

$$\begin{aligned} \frac{(H + 2F) - 2\left(\frac{F}{B^2} \cdot 4\right)x^2}{(h + 2f) - 2\left(\frac{f}{B^2} \cdot 4\right)x^2} &= \frac{H + 2F \left[1 - \left(\frac{4}{B^2}\right)x^2\right]}{h + 2f \left[1 - \left(\frac{4}{B^2}\right)x^2\right]} = \\ &= \frac{\mu \left[h + 2f \left\{ 1 - \left(\frac{4}{B^2}\right)x^2 \right\} \right]}{h + 2f \left[1 - \left(\frac{4}{B^2}\right)x^2 \right]} = \mu = \text{const} . \end{aligned}$$

Assume that the condition for strip metal elongation uniformity at the output of the i -th stand is

$$\int_{i-1} - \int_i \left(\frac{h_{i-1}}{h_i} \right) = 0 . \quad (6.9)$$

Strip non-flatness occurs at a certain largest admissible elongation non-uniformity which can be found experimentally. In other words, in controlling the strip geometry, the inequality

$$\left| \int_{i-1} - \int_i \left(\frac{h_{i-1}}{h_i} \right) \right| \leq [\delta_i] \quad (6.10)$$

should be met, where:

i = ordinal number of the stand, ($i = 1, 2, \dots, N$);

$[\delta_i]$ = largest admissible value of non-uniformity of elongation along the strip width at which the strip maintains stability.

Let us use the inequality (6.10) as a constraint in strip geometry control; for this purpose let us express (6.10) through the technological parameters.

Let us take up the first inter-stand area

$$\Delta P_1 = \bar{M}_{St1} K_{H1} \Delta \bar{H}_1 + \bar{M}_{St1} K_{T1} \Delta T_1 - M_{mi} K_{S1} \Delta S_1 \quad .$$

Denote:

$$\frac{\bar{M}_{ti}}{C_{ri}} = \gamma_i \quad ; \quad \tilde{K}_{Si} = \frac{M_{mi}}{M_{mi} + \bar{M}_{Sti}} \quad .$$

Then

$$f_1 = \Delta P_1 \frac{1}{C_{r1}} = (\gamma_1 K_{H1}) \Delta \bar{H}_1 + (\gamma_1 K_{T1}) \Delta T_1 - (\gamma_1 \tilde{K}_{S1}) \Delta S_1 \quad .$$

Replace the ratio $(\frac{h_{i-1}}{h_1})$ in the inequality (6.10) by the ratio $(\frac{h_{i-1, nom}}{h_i nom})$; then, denoting $\frac{h_{i-1, nom}}{h_i nom} = \alpha_i$ gives the flatness condition for the first inter-stand area,

$$\left| f_0 - \alpha_1 \gamma_1 K_{H1} \Delta H_1 - \alpha_1 \gamma_1 K_{T1} \Delta T_1 + \alpha_1 \gamma_1 \tilde{K}_{S1} \Delta S_1 \right| \leq S_7 \quad ;$$

or, assuming that the roughed slab of the first stand does not have lateral thickness variation ($f_0 = 0$), we will have

$$\Delta S_1 K_{71} \leq |\delta_7| - \Delta W_7 \quad ,$$

where

$$K_{71} = \alpha \gamma_1 \tilde{K}_{S1} \quad (\gamma_1 = \gamma_2 = \dots = \gamma_7 = \gamma) \quad (6.11)$$

$$\Delta W_7 = \tilde{K}_{71} \Delta \bar{H}_1 + \tilde{K}_{72} \Delta T_1$$

(where

$$\tilde{K}_{71} = -\gamma \alpha_1 K_{H1} \quad ; \quad \tilde{K}_{72} = -\gamma \alpha_1 K_{T1} \quad) \quad .$$

Let us take up the second inter-stand area ($i = 2$):

$$\Delta P_2 = \bar{M}_{St2} \Delta \bar{h}_2 \quad ; \quad \Delta \bar{h}_2 = K_{H2} \Delta \bar{H}_2 + K_{T2} \Delta T_2 + K_{S2} \Delta S_2 \quad ;$$

$$\begin{aligned} \Delta P_2 = & \bar{M}_{St2} K_{H1} K_{H2} \Delta \bar{H}_1 + \bar{M}_{St2} K_{T1} \Delta T_1 + \Delta T_1 + \bar{M}_{St2} K_{T2} \Delta T_2 + \\ & + \bar{M}_{St2} K_{S1} K_{H2} \Delta S_1 - M_{m2} K_{S2} \Delta S_2 \quad ; \end{aligned}$$

$$\begin{aligned} f_2 = & \gamma_2 K_{H1} K_{H2} \Delta \bar{H}_1 + \gamma_2 K_{T1} K_{H2} \Delta T_1 + \gamma_2 K_{T2} \Delta T_2 + \\ & + \gamma_2 K_{S1} K_{H2} \Delta S_1 - \gamma_2 \tilde{K}_{S2} \Delta S_2 \quad . \end{aligned}$$

Then the condition (6.10) for the second inter-stand area will be

$$\begin{aligned} |f_1 - \alpha_2 f_2| = & |\Delta H_1 (\gamma_1 K_{H1}) + \Delta T_1 (\gamma_1 K_{T1}) + \Delta S_1 (-\gamma_1 \tilde{K}_{S1}) - \\ & - \Delta H_1 (\alpha_2 \gamma_2 K_{H1} K_{H2}) - \Delta T_1 (\alpha_2 \gamma_2 K_{T1} K_{H2}) - \\ & - \Delta T_2 (\alpha_2 \gamma_2 K_{T2}) - \Delta S_1 (\alpha_2 \gamma_2 K_{S1} K_{H2}) + \Delta S_2 (\alpha_2 \gamma_2 \tilde{K}_{S2}) \quad ; \end{aligned}$$

or

(6.12)

$$\Delta S_1 K_{61} + \Delta S_2 K_{62} \leq |\delta_6| - \Delta W_6 \quad ,$$

where

$$K_{61} = \gamma K_{S1} \left(-\frac{M_{m1}}{\bar{M}_{St1}} - \alpha_2 K_{H2} \right) \quad ; \quad K_{62} = \gamma \alpha_2 \tilde{K}_{S2} \quad ;$$

$$\Delta W_6 = \Delta H_1 \tilde{K}_{61} + \Delta T_1 \tilde{K}_{62} + \Delta T_2 \tilde{K}_{63} \quad ;$$

$$\tilde{K}_{61} = \gamma K_{H1} \beta_2 \quad ; \quad K_{62} = \gamma K_{T1} \beta_2 \quad ;$$

$$\tilde{K}_{63} = -\gamma \alpha_2 K_{T2} \quad ; \quad \beta_2 = 1 - \alpha_2 K_{H2} \quad .$$

Following analogous transformation, we will have for $i = 3$,

$$K_{51}\Delta S_1 + K_{52}\Delta S_2 + K_{53}\Delta S_3 \leq |\delta_5| - \Delta W_5 \quad (6.13)$$

$$\Delta W_5 = \tilde{K}_{51}\Delta \bar{H}_1 + \tilde{K}_{52}\Delta T_1 + \tilde{K}_{53}\Delta T_2 + \tilde{K}_{54}\Delta T_3 \quad ,$$

where

$$K_{51} = \gamma K_{S1} K_{H2} \beta_3 \quad ; \quad K_{52} = \gamma K_{S2} \left(- \frac{M_{m2}}{M_{St2}} - \alpha_3 K_{H3} \right) \quad ;$$

$$K_{53} = \gamma \alpha_3 \tilde{K}_{S3} \quad ; \quad \beta_3 = 1 - \alpha_3 K_{H3} \quad ;$$

$$\tilde{K}_{51} = \gamma K_{H1} K_{H2} \beta_3 \quad ; \quad \tilde{K}_{52} = \gamma K_{T1} K_{H2} \beta_3 \quad ;$$

$$\tilde{K}_{53} = \gamma K_{T2} \beta_3 \quad ; \quad \tilde{K}_{54} = - \gamma \alpha_3 K_{T3} \quad .$$

For $i = 4$

$$K_{41}\Delta S_1 + K_{42}\Delta S_2 + K_{43}\Delta S_3 + K_{44}\Delta S_4 \leq |\delta_4| - \Delta W_4 \quad (6.14)$$

$$\Delta W_4 = \tilde{K}_{41}\Delta H_1 + \tilde{K}_{42}\Delta T_1 + \tilde{K}_{43}\Delta T_2 + \tilde{K}_{44}\Delta T_3 + \tilde{K}_{45}\Delta T_4 \quad ,$$

where

$$K_{41} = \gamma K_{S1} K_{H2} K_{H3} \beta_4 \quad ; \quad K_{42} = \gamma K_{S2} K_{H3} \beta_4 \quad ;$$

$$K_{43} = \gamma K_3 \left(- \frac{M_{m3}}{M_{St3}} - \alpha_4 K_{H4} \right) \quad ; \quad K_{44} = \gamma \alpha_4 \tilde{K}_{S4} \quad ;$$

$$\beta_4 = 1 - \alpha_4 K_{H4} \quad ; \quad \tilde{K}_{41} = \gamma K_{H1} K_{H2} K_{H3} \beta_4 \quad ;$$

$$\tilde{K}_{42} = \gamma K_{T1} K_{H2} K_{H3} \beta_4 \quad ; \quad \tilde{K}_{43} = \gamma K_{T2} K_{H3} \beta_4 \quad ;$$

$$\tilde{K}_{44} = \gamma K_{T3} \beta_4 \quad ; \quad \tilde{K}_{45} = - \gamma \alpha_4 K_{T4} \quad .$$

For $i = 5$,

(6.15)

$$K_{31}\Delta S_1 + K_{32}\Delta S_2 + K_{33}\Delta S_3 + K_{34}\Delta S_4 + K_{35}\Delta S_5 \leq |\delta_3| - \Delta W_3$$

$$\Delta W_3 = \tilde{K}_{31}\Delta \bar{H}_1 + \tilde{K}_{32}\Delta T_1 + \tilde{K}_{33}\Delta T_2 + \tilde{K}_{34}\Delta T_3 + \tilde{K}_{35}\Delta T_4 + \tilde{K}_{36}\Delta T_5 ,$$

where

$$K_{31} = \gamma K_{S1} K_{H2} K_{H3} K_{H4} \beta_5 ; \quad K_{32} = \gamma K_{S2} K_{H3} K_{H4} \beta_5 ;$$

$$K_{33} = \gamma K_{S3} K_{H4} \beta_5 ; \quad K_{34} = \gamma K_{S4} \left(-\frac{M_{m3}}{M_{St3}} - \alpha_5 K_{H5} \right) ;$$

$$K_{35} = \gamma \alpha_5 \tilde{K}_{S5} ; \quad \beta_5 = 1 - \alpha_5 K_{H5} ;$$

$$\tilde{K}_{31} = \gamma K_{H1} K_{H2} K_{H4} \beta_5 ; \quad \tilde{K}_{32} = \gamma K_{T1} K_{H2} K_{H3} \beta_5 ;$$

$$\tilde{K}_{33} = \gamma K_{T2} K_{H2} K_{H3} K_{H4} \beta_5 ; \quad \tilde{K}_{34} = \gamma K_{T3} K_{H4} \beta_5 ;$$

$$\tilde{K}_{35} = \gamma K_{T4} \beta_5 ; \quad \tilde{K}_{36} = -\gamma \alpha_5 K_{T5} .$$

For $i = 6$,

(6.16)

$$K_{21}\Delta S_1 + K_{22}\Delta S_2 + K_{23}\Delta S_3 + K_{24}\Delta S_4 + K_{25}\Delta S_5 + K_{26}\Delta S_6 =$$

$$= |\delta_2| - \Delta W_2$$

$$\Delta W_2 = \tilde{K}_{21}\Delta \bar{H}_1 + \tilde{K}_{22}\Delta T_1 + \tilde{K}_{23}\Delta T_2 + \tilde{K}_{24}\Delta T_3 + \tilde{K}_{25}\Delta T_4 + \tilde{K}_{26}\Delta T_5 +$$

$$+ \tilde{K}_{27}\Delta T_6 ,$$

where

$$K_{21} = \gamma K_{S1} K_{H2} \cdots K_{H5} \beta_5 ; \quad K_{22} = \gamma K_{S2} K_{H3} \cdots K_{H5} \beta_5 ;$$

$$K_{23} = \gamma K_{S3} K_{H4} K_{H5} \beta_6 ; \quad K_{24} = \gamma K_{S4} K_{H5} \beta_6 ;$$

$$\begin{aligned}
 K_{25} &= \gamma K_{S5} \left(-\frac{M_{m5}}{M_{t5}} - \alpha_6 K_{H6} \right) ; & K_{26} &= \gamma \alpha_6 \tilde{K}_6 ; \\
 \tilde{K}_{21} &= \gamma K_{H1} \cdots K_{H5} \beta_6 ; & \tilde{K}_{22} &= \gamma K_{T1} K_{H2} \cdots K_{H5} \beta_6 ; \\
 \tilde{K}_{23} &= \gamma K_{T2} K_{H3} K_{H4} K_{H5} \beta_5 ; & \tilde{K}_{24} &= \gamma K_{T3} K_{H4} K_{H5} \beta_6 ; \\
 \tilde{K}_{25} &= \gamma K_{T4} K_{H5} \beta_6 ; & \tilde{K}_{26} &= \gamma K_{T5} \beta_6 ; \\
 \tilde{K}_{27} &= -\gamma \alpha_6 K_{T6} ; & \beta_6 &= 1 - \alpha_6 K_{H6} .
 \end{aligned}$$

For $i = 7$,

$$K_{11} \Delta S_1 + K_{12} \Delta S_2 + \cdots + K_{17} \Delta S_7 \leq |\delta_1| - \Delta W_1 \quad (6.17)$$

$$\Delta W_1 = \tilde{K}_{11} \Delta \bar{H}_1 + \tilde{K}_{12} \Delta T_1 + \tilde{K}_{13} \Delta T_2 + \cdots + \tilde{K}_{18} \Delta T_7 ,$$

where

$$\begin{aligned}
 K_{11} &= \gamma K_{S1} K_{H2} \cdots K_{H6} \beta_7 ; & K_{12} &= \gamma K_{12} K_{H3} \cdots K_{H6} \beta_7 ; \\
 K_{13} &= \gamma K_{S3} K_{H4} \cdots K_{H6} \beta_7 ; & K_{14} &= \gamma K_{S4} K_{H5} K_{H6} \beta_7 ; \\
 K_{15} &= \gamma K_{S5} K_{H6} \beta_7 ; & K_{16} &= \gamma K_{S6} (-1 - \alpha_7 K_{H7}) ; \\
 K_{17} &= \gamma \tilde{K}_{S7} ; & \beta_7 &= 1 - \alpha_7 K_{H7} ; \\
 \tilde{K}_{11} &= \gamma K_{H1} \cdots K_{H6} \beta_7 ; & \tilde{K}_{12} &= \gamma K_{T1} K_{H2} \cdots K_{H6} \beta_7 ; \\
 \tilde{K}_{13} &= \gamma K_{T2} K_{H3} \cdots K_{H6} \beta_7 ; & \tilde{K}_{14} &= \gamma K_{T3} K_{H4} \cdots K_{H6} \beta_7 ; \\
 \tilde{K}_{15} &= \gamma K_{T4} K_{H5} K_{H5} \beta_7 ; & \tilde{K}_{16} &= \gamma K_{T5} K_{H6} \beta_7 ; \\
 \tilde{K}_{17} &= \gamma K_{T6} \beta_7 ; & K_{18} &= -\gamma \alpha_7 K_{T7} .
 \end{aligned}$$

6.4 Solution Procedure

Making the optimality criterion (6.8) equal to zero, we will have

$$K_{O1}\Delta S_1 + K_{O2}\Delta S_2 + \dots + K_{O7}\Delta S_7 = -\Delta W_0 \quad (6.18)$$

$$\Delta W_0 = \tilde{K}_{O1}\bar{H}_1 + \tilde{K}_{O2}\Delta T_1 + \dots + \tilde{K}_{O7}\Delta T_6 + \tilde{K}_{O8}\Delta T_7 \quad ,$$

where

$$\begin{aligned} K_{O1} &= K_{H7}K_{H6} \dots K_{H2}K_1 \quad ; & K_{O2} &= K_{H7}K_{H6} \dots K_{H3}K_2 \quad ; \\ K_{O3} &= K_{H7}K_{H6} \dots K_{H4}K_2 \quad ; & K_{O4} &= K_{H7}K_{H6}K_{H5}K_4 \quad ; \\ K_{O5} &= K_{H7}K_{H6}K_{S5} \quad ; & K_{O6} &= K_{H7}K_{S6} \quad ; & K_{O7} &= K_{S7} \quad ; \\ \tilde{K}_{O1} &= K_{H7}K_{H6} \dots K_{H1} \quad ; & \tilde{K}_{O2} &= K_{H7} \dots K_{H2}K_{T1} \quad ; \\ \tilde{K}_{O3} &= K_{H7} \dots K_{H2}K_{T2} \quad ; & \tilde{K}_{O4} &= K_{H7} \dots K_{H4}K_{T3} \quad ; \\ \tilde{K}_{O5} &= K_{H7} \dots K_{H5}K_{T4} \quad ; & \tilde{K}_{O6} &= K_{H7}K_{H6}K_{T5} \quad ; \\ \tilde{K}_{O7} &= K_{H7}K_{H6} \quad ; & \tilde{K}_{O8} &= K_{T7} \quad . \end{aligned}$$

A complete inequality system for no non-flatness in all inter-stand areas and on the delivery table will be

$$K_{11}\Delta S_1 + K_{12}\Delta S_2 + \dots + K_{16}\Delta S_6 \leq \delta_1 - \Delta W_1 \quad (1) \quad (6.19)$$

$$-K_{11}\Delta S_1 - K_{12}\Delta S_2 - \dots - K_{16}\Delta S_6 \leq \delta_1 + \Delta W_1 \quad (2)$$

$$K_{21}\Delta S_1 + K_{22}\Delta S_2 + \dots + K_{26}\Delta S_6 \leq \delta_2 + \Delta W_1 \quad (3)$$

$$-K_{21}\Delta S_1 - K_{22}\Delta S_2 - \dots - K_{26}\Delta S_6 \leq \delta_2 + \Delta W_2 \quad (4)$$

$$K_{31}\Delta S_1 + K_{32}\Delta S_2 + \dots + K_{36}\Delta S_5 \leq \delta_2 - \Delta W_3 \quad (5)$$

$$- K_{31}\Delta S_1 - K_{32}\Delta S_2 - \dots - K_{36}\Delta S_5 \leq \delta_3 + \Delta W_3 \quad (6)$$

$$K_{41}\Delta S_1 + K_{42}\Delta S_2 + \dots + K_{46}\Delta S_4 \leq \delta_4 + \Delta W_4 \quad (7)$$

$$- K_{41}\Delta S_1 - K_{42}\Delta S_2 - \dots - K_{46}\Delta S_4 \leq \delta_4 + \Delta W_4 \quad (8)$$

.....

.....

$$K_{71}\Delta S_1 \leq \delta_7 - \Delta W_7 \quad (13)$$

$$- K_{71}\Delta S_1 \leq \delta_7 + \Delta W_7, \quad (14)$$

where the first two inequalities define the conditions for non-flatness at the last stand ($i = 7$); the subsequent two inequalities define the non-flatness conditions at the sixth stand exit ($i = 6$), etc.

The last two inequalities define the non-flatness condition at the first stand exit ($i = 1$). Let us transform the inequalities (6.19) into a system of equations; to do this, add the non-negative variables $\nabla_1, \nabla_8, \nabla_2, \nabla_9, \nabla_3, \nabla_{10}, \nabla_4, \nabla_{11}, \nabla_5, \nabla_{12}, \nabla_6, \nabla_{13}, \nabla_7, \nabla_{14}$ to the left-hand parts of inequalities (1), (2), (3), ..., (14), and then add up the equations and arrive at an equivalent system

$$K_{11}\Delta S_1 + K_{12}\Delta S_2 + \dots + K_{16}\Delta S_6 + \nabla_1 = \delta_1 - \Delta W_1 = A_1$$

$$K_{21}\Delta S_1 + K_{22}\Delta S_2 + \dots + K_{26}\Delta S_6 + \nabla_2 = \delta_2 - \Delta W_2 = A_2$$

$$K_{31}\Delta S_1 + K_{32}\Delta S_2 + \dots + K_{35}\Delta S_5 + \nabla_3 = \delta_3 - \Delta W_3 = A_3$$

$$K_{41}\Delta S_1 + K_{42}\Delta S_2 + \dots + K_{44}\Delta S_4 + \nabla_4 = \delta_4 - \Delta W_4 = A_4$$

$$K_{51}\Delta S_1 + K_{52}\Delta S_2 + \dots + \nabla_5 = \delta_5 - \Delta W_5 = A_5$$

$$\begin{aligned}
 K_{61}\Delta S_1 + K_{62}\Delta S_2 + \dots + & \quad \nabla_6 = \delta_6 - \Delta W_6 = A_6 \\
 K_{71}\Delta S_1 & \quad \nabla_7 = \delta_7 - \Delta W_7 = A_7 \\
 \nabla_1 + \nabla_8 = 2\delta_1 & \quad (6.20) \\
 \nabla_2 + \nabla_9 = 2\delta_2 \\
 \dots\dots\dots \\
 \dots\dots\dots \\
 \nabla_7 + \nabla_{14} = 2\delta_7 \quad .
 \end{aligned}$$

Denote $\nabla_i - A_i = \gamma_i$ ($i = 1, 2, \dots, 7$). Then, for the vector components $\Delta S (\Delta S_1, \Delta S_2, \dots, \Delta S_6)$, following the appropriate solutions, we will have the expression

$$\Delta S_i = \sum_{m=1}^{i=1} (-1)^{n_m} \frac{|A_{im}|}{\prod_{im}} \gamma_{(8-m)} - \frac{1}{K_{(8-i),i}} \gamma_{(8-1)} \quad , \quad (6.21)$$

where the matrix A_{i1} of the sum (6.21) is found through transformation of the initial matrix:

$$A_{i0} = \begin{pmatrix} K_{21}K_{22}K_{23}K_{24}K_{25} \\ K_{31}K_{32}K_{33}K_{34}K_{35} \\ K_{41}K_{42}K_{43}K_{44}K_{45} \\ K_{51}K_{52}K_{53}K_{54}K_{55} \\ K_{61}K_{62}K_{63}K_{64}K_{65} \end{pmatrix} \quad , \quad (6.22)$$

by crossing out $(6 - i)$ upper rows and as many right-hand columns.

Π_{i1} is the product of the technological factors and is determined as $\Pi_0 = K_{71}K_{62}K_{53}K_{44}K_{35}K_{26}$ by making $(6 - i)$ multipliers on the right-hand side equal to unity.

The matrixes $A_{i2}, A_{i3}, \dots, A_{i,i-1}$ are obtained from the matrix by crossing out $1, 2, \dots, (i - 2)$ columns on the left and as many lower-most rows.

The products $\Pi_{i2}, \Pi_{i3}, \dots, \Pi_{i,i-1}$ are obtained by equating $1, 2, \dots, (i - 2)$ multipliers on the left to unity; n_m is the number of zeros in the matrix A_{im} .

Thus, for the increment of the coordinate of the screw-down in the fourth stand ($i = 4$), we will have

$$\Delta S_4 = - \frac{\begin{vmatrix} K_{41}K_{42}K_{43} \\ K_{51}K_{52}K_{53} \\ K_{61}K_{62}K_{63} \end{vmatrix}}{K_{71}K_{62}K_{53}K_{44}} (\nabla_7 - A_7) + \frac{\begin{vmatrix} K_{42}K_{43} \\ K_{52}K_{53} \end{vmatrix}}{K_{62}K_{53}K_{44}} (\nabla_6 - A_6) + \\ + \frac{K_{43}}{K_{53}K_{44}} (\nabla_5 - A_5) - \frac{1}{K_{44}} (\nabla_4 - A_4) .$$

Substitution of (6.21) into (6.20) gives an equation for flatness in the inter-stand areas

$$b_{11}\nabla_1 + b_{12}\nabla_2 + \dots + b_{17}\nabla_7 = z_1 \quad (6.23)$$

$$z_1 = b^*_{11}A_1 + b^*_{12}A_2 + \dots + b^*_{17}A_7 ,$$

where

$$b_{1i} = b^*_{1i} \quad (i = 1, 2, \dots, 7) ; \quad (6.24)$$

$$b_{1i} = (-1)^{n+1} \frac{|B_{1i}|}{\Pi_{1i}} ;$$

b_{1i} is a matrix obtained from transformation of the matrix:

$$B_{17} = \begin{pmatrix} K_{11}K_{12}K_{13}K_{14}K_{15}K_{16} \\ K_{21}K_{22}K_{23}K_{24}K_{25}K_{26} \\ K_{31}K_{32}K_{33}K_{34}K_{35}0 \\ K_{41}K_{42}K_{43}K_{44}0 \quad 0 \\ K_{51}K_{52}K_{53}0 \quad 0 \quad 0 \\ K_{61}K_{62}0 \quad 0 \quad 0 \quad 0 \end{pmatrix}$$

by crossing out $(7 - i)$ columns on the left and as many rows below;

Π_{1i} is a product of the technological parameters obtained from the product $\Pi_{17} = K_{71}K_{62}K_{53}K_{44}K_{35}K_{26}$ by equating $(7 - i)$ multipliers on the left to unity; in other words, the factor of ∇_4 (or b_{14}) is

$$b_{14} = \frac{(-1)^{n_i+1}}{K_{44}K_{35}K_{26}} \begin{vmatrix} K_{14}K_{15}K_{16} \\ K_{24}K_{25}K_{26} \\ K_{34}K_{35}K_{36} \end{vmatrix} ;$$

n_i is the number of zeros in the transformed matrix B_{1i} .

Substituting equation (6.18) into (6.21) and defining zero thickness variation at the output of the last stand gives

$$b_{21}0 + b_{22}\nabla_2 + b_{23}\nabla_3 + \dots + b_{27}\nabla_7 = z_2 \quad (6.25)$$

$$z_2 = b^*_{21}A_0 + b^*_{22}A_2 + \dots + b^*_{27}A_7 ,$$

where

$$- \Delta W_7 = A_0 ; \quad b_{2i} = b^*_{2i} .$$

The coefficients b_{2i} are determined by the same formulae as b_{i1} or (6.24) if A_1, ∇_1, K_{1i} are replaced by $A_0, 0, K_{0i}$, respectively; in other words, for the transition $b_{i1} \rightarrow b_{i2}$ it is necessary that

$$A_1 = A_0 ; \quad \nabla_1 = 0 ; \quad K_{1i} = K_{0i} .$$

Then we will have

$$b_{2i} = (-1)^{n+1} \frac{|B_{2i}|}{\Pi_{2i}} , \tag{6.26}$$

where $\Pi_{2i} = \Pi_{1i}$, $|B_{2i}| = |B_{1i}|$ with $K_{1i} = K_{0i}$; n is the number of zeros in the transformed matrix B_{2i} .

Consequently, the solution of the problem is reduced to solving the equation system

$$b_{11}\nabla_1 + b_{12}\nabla_2 + \dots + b_{17}\nabla_7 = Z_1 \tag{6.27}$$

$$b_{21}0 + b_{22}\nabla_2 + \dots + b_{27}\nabla_7 = Z_2$$

$$\nabla_1 + \nabla_8 = 2\delta_1$$

.....

.....

.....

$$\nabla_7 + \nabla_{14} = 2\delta_7 .$$

To solve system (6.27), let us use a simplex method. Introduce a number of non-negative variables ∇_i that is equal to the number of equations in system (6.27).

Then we have the following linear programming problem:

find a vector $\nabla(\nabla_1, \nabla_2, \dots, \nabla_{14})$, minimizing the linear form

$$\sum_{j=1}^g U_j \rightarrow \min \tag{6.28}$$

whose variables satisfy the constraints (6.29)

$$\begin{aligned} b_{11}\nabla_1 + b_{12}\nabla_2 + b_{13}\nabla_3 + b_{14}\nabla_4 + b_{15}\nabla_5 + b_{16}\nabla_6 + b_{17}\nabla_7 + U_1 &= Z_1 \\ b_{22}\nabla_2 + b_{23}\nabla_3 + b_{24}\nabla_4 + b_{25}\nabla_5 + b_{26}\nabla_6 + b_{27}\nabla_7 + U_2 &= Z_2 \\ & \dots \dots \dots \\ & \dots \dots \dots \\ \nabla_1 + \nabla_8 + U_3 &= 2\delta_1 \\ & \dots \dots \dots \\ & \dots \dots \dots \\ \nabla_7 + \nabla_{14} + U_9 &= 2\delta_7 \\ U_1 \geq 0 \ ; \ U_2 \geq 0 \ ; \dots \dots \dots \nabla_1 \geq 0 \ ; \\ \nabla_2 \geq 0 \ ; \dots \dots \dots \nabla_{14} \geq 0 \ . \end{aligned}$$

The problem was solved on an ICL 4-70 Computer for a 1700 HSM.

6.5 Computation Results

The above approach was tested on thin sheet rolling with the use of the above models.

Table 6.1 gives the reduction conditions in the finishing train.

Table 6.2 gives data characterizing the finishing rolling temperature in the finishing stands (from the head end of one strip to the tail end of the other).

Table 6.1

Strip Thickness and Width, mm	Absolute Reduction of Metals in Finishing Train Stands (mm)						
	Stand Number						
	1	2	3	4	5	6	7
1.2 x 1250	15.00	5.90	2.35	1.30	0.80	0.28	0.17
1.6 x 1250	14.50	6.10	2.30	1.20	0.30	0.35	0.15
1.8 x 1250	16.00	7.20	3.70	1.40	1.20	0.45	0.25
2.0 x 1250	16.00	7.00	3.40	1.70	1.20	0.45	0.25
3.0 x 1250	18.50	6.30	3.20	1.75	1.21	0.79	0.25
4.0 x 1250	13.60	8.10	3.80	2.50	1.59	0.99	0.42

Table 6.2

Strip Thickness and Width, mm	End-of-Rolling Temperature in the Finishing Stands, °C						
	Stand Number						
	1	2	3	4	5	6	7
1.2 x 1250	-174	-144	-110	-82	-63	-48	-36
1.6 x 1250	-94	-74	-62	-53	-45	-35	-28
1.8 x 1250	-84	-71	-56	-48	-40	-30	-23
2.0 x 1250	-73	-62	-52	-45	-38	-30	-26
3.0 x 1250	-65	-56	-48	-42	-37	-30	-25
4.0 x 1250	-48	-42	-37	-33	-30	-26	-24

Figures 6.3 and 6.4 graphically represent the results of simulating the control of 1.2 x 1250 mm strip gage by the method proposed, and by the Sims-Golovin method. The strip length was divided into five sections, and the thickness adjusted at the end of each section. The gage controllers implementing the Sims-Golovin method are ideally adjusted; in other words, they fully compensate for all the disturbances in the mill line.

Figure 6.3 is a plot of the screw replacements for the cases considered and Figure 6.4 shows the associated increments of stand load along the strip length.

Figures 6.5-6.10 represent similar functions for strips measuring 1.6 x 1250 mm, 1.8 x 1250 mm, and 2.0 x 1250 mm.

Analysis of the resulting dependences reveals that, in the method proposed, the last continuous group stands are unloaded and the first ones are loaded. As a result, the stand load is stabilized, and consequently the strip is always flat in the last inter-stand area. This is confirmed by the curves of Figures 6.11-6.14. The strip stability margin is obviously much better than that obtained by the conventional method of gage control.

The proposed method of simultaneous gage and shape control of the strip has one disadvantage in thin strip rolling. With the low threading speed, the front part of the strip usually has a finishing rolling temperature lower than that of the remaining part, due to higher load in the last stands. Thus, in the proposed method, metal reduction in the first stands is increased in order to keep the load of the last stands at the predetermined value. But increased metal reduction in the first stands results in higher heat losses of the metal and additional decrease in finishing rolling temperature. Therefore, this method can be used only in cases where the finishing rolling temperature is not limited by the rolling speed, that is, for thick strip rolling and for rolling thin strips after coiling has started.

For thin strip rolling, metal reduction in the last stands should thus be increased when rolling the front part of the strip; the shape is controlled by roll bending hydraulic systems. After the rolling speed has increased sufficiently, the proposed method can be applied.

Conclusion

As has been shown, the problem of increasing hot strip mill production efficiency consists of several interrelated sub-problems, some of which are of a conflicting nature. Investigation by systems analysis has permitted identification of the most critical combinations of technological limitations, and formulation of some new methods for reducing the influence of those limitations on the production process. In general, the problems are related to obtaining the required finishing rolling temperature and strip shape at the highest permissible rolling speed.

The new methods proposed in this paper are:

- 1) The use of thinner slabs when thick strips are to be rolled (to permit a lower slab heating temperature);
- 2) The use of roughed-slab head end heating when rolling thin strips;
- 3) The use of roughed slabs of varying thickness to obtain higher finishing rolling temperatures when thin strips are manufactured;
- 4) The redistribution of metal reduction among the finishing stands to obtain a higher finishing rolling temperature of the strip head end and a higher rolling speed after the strip is threaded into the coiler;
- 5) The redistribution of metal reduction among the finishing stands to stabilize strip shape and gage.

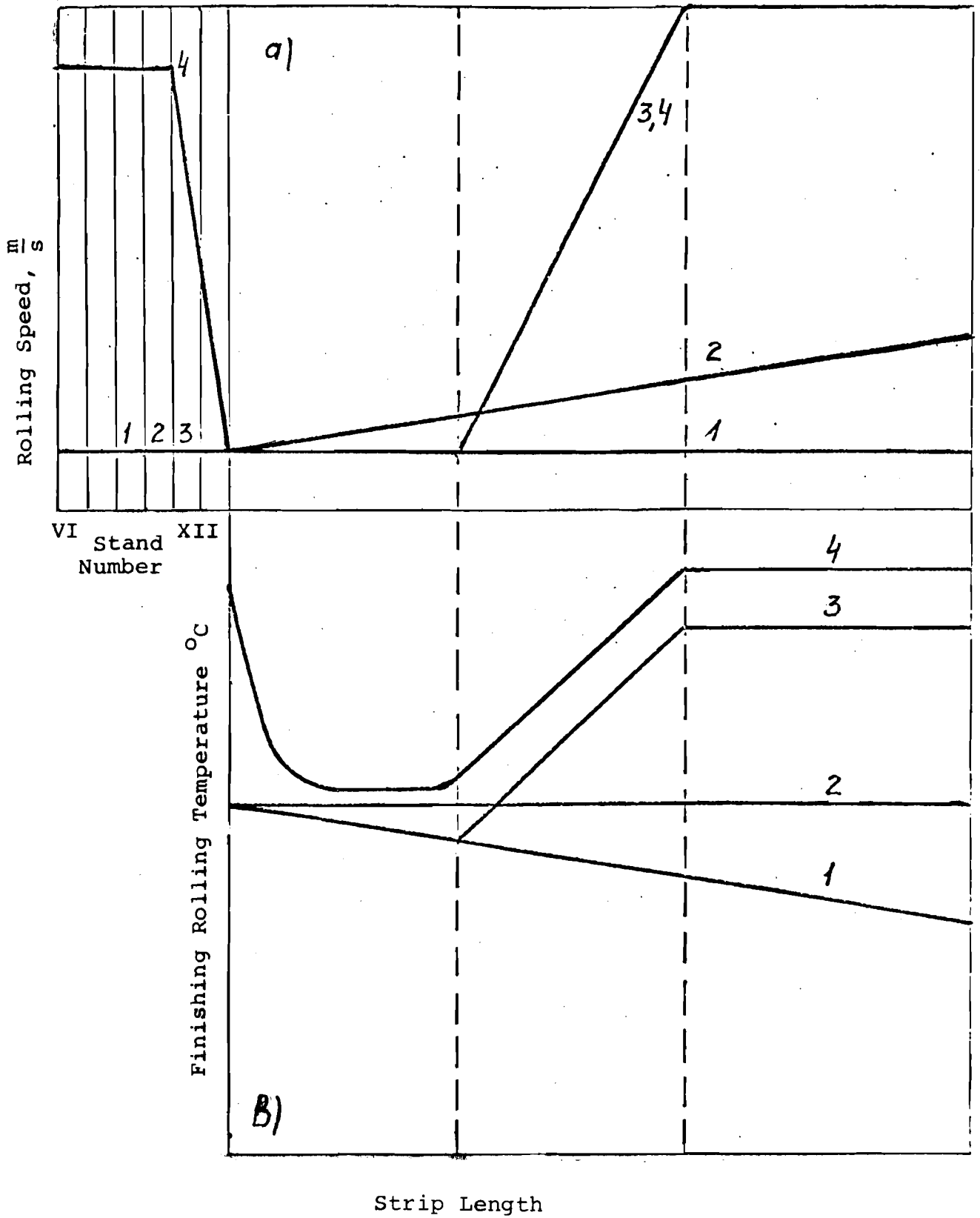

Figure 4.1. Types of rolling speed patterns (a) and distribution of T_{fd} along the strip (b).

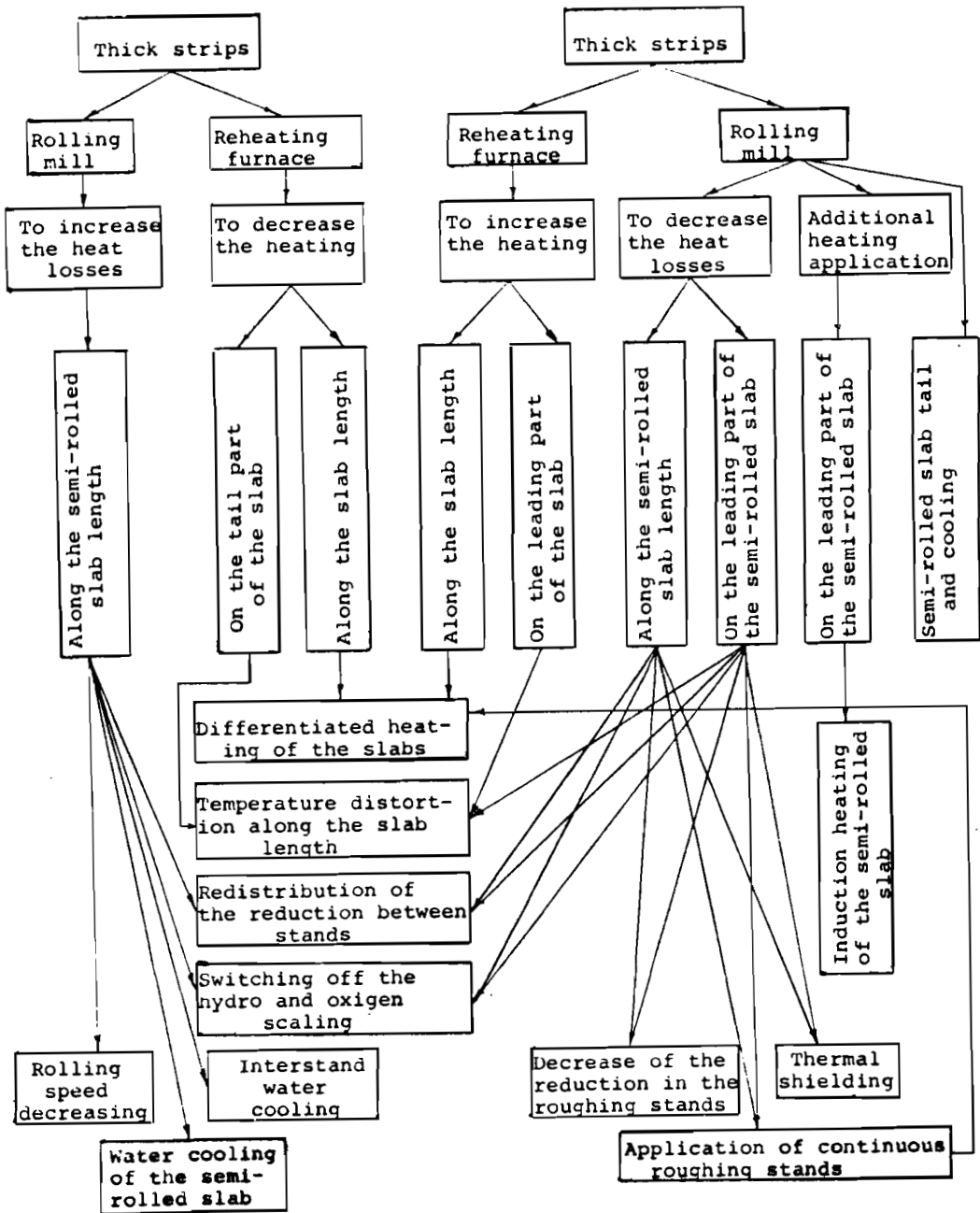

Figure 4.2. Possibilities of improving hot rolled strip quality.

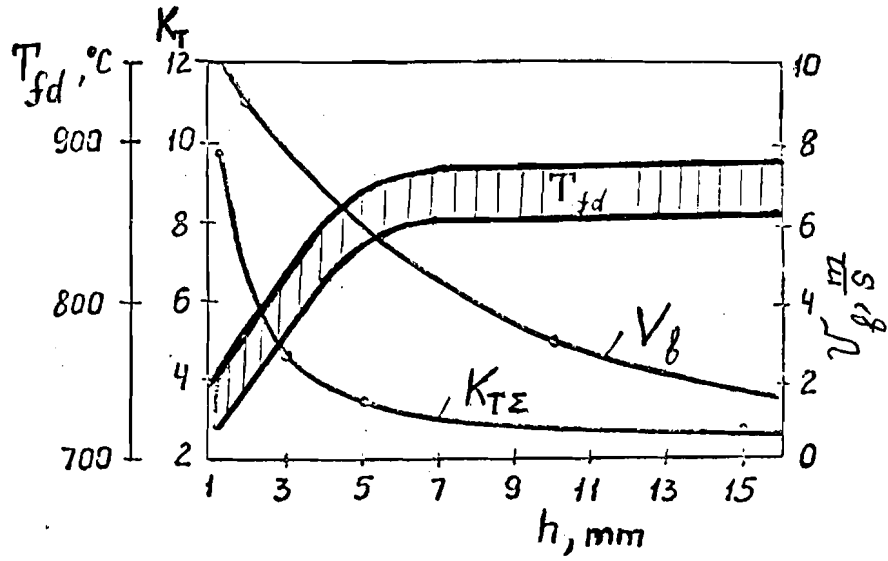

Figure 4.3. Dependence of T_{fd} , K_T , V_b on strip thickness (V_b , T_{fd} were obtained in the experiment).

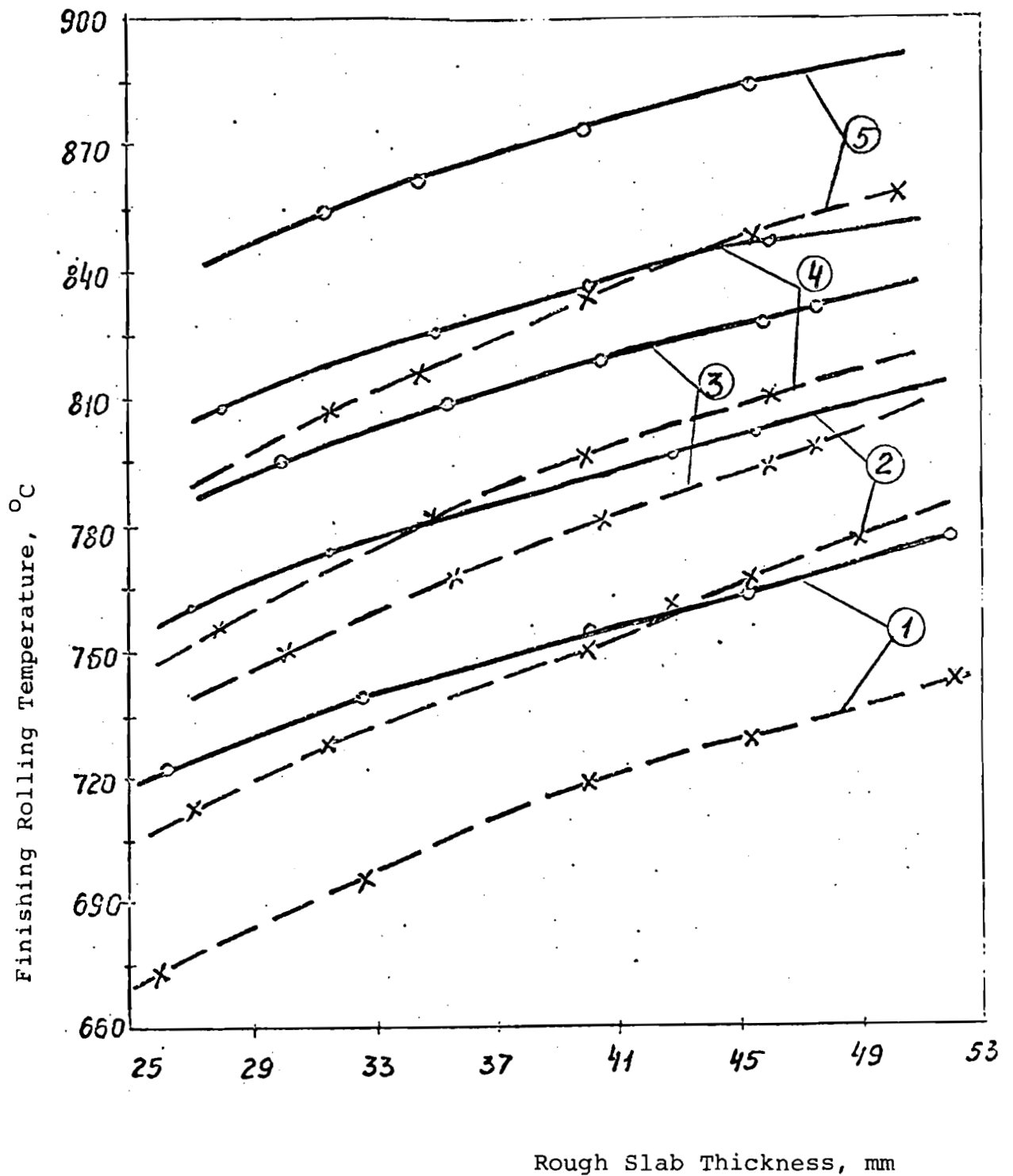

Figure 5.1. Dependence of finishing rolling temperature on strip and roughed-slab thickness. Strip thicknesses: 1 → 1.2 mm; 2 → 1.5 mm; 3 → 2.0 mm; 4 → 3.0 mm; 5 → 5.0 mm.

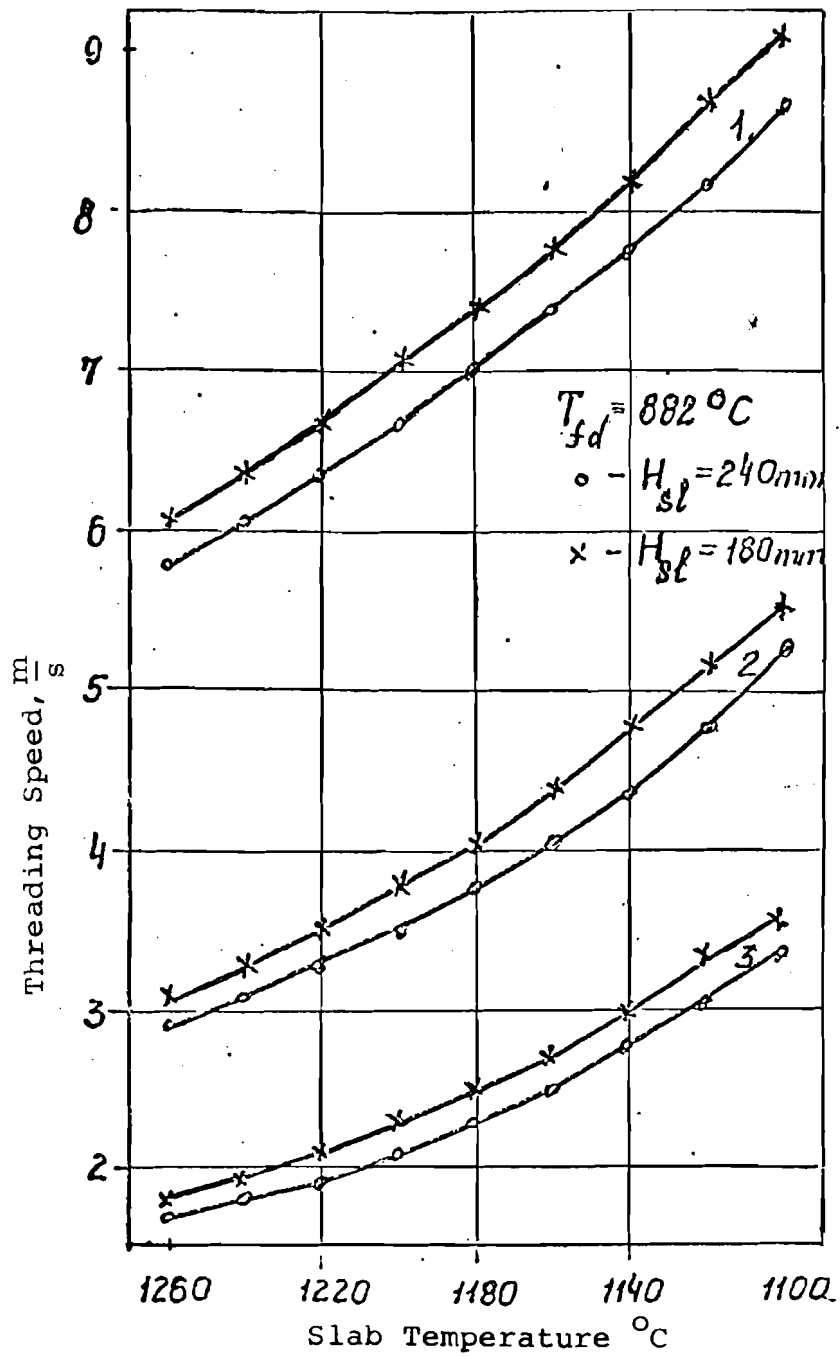

Figure 5.2. Dependence of threading speed on slab temperature.

- 1 h = 5.0 mm;
- 2 h = 10.0 mm;
- 3 h = 16.0 mm; H_p = 40 mm.

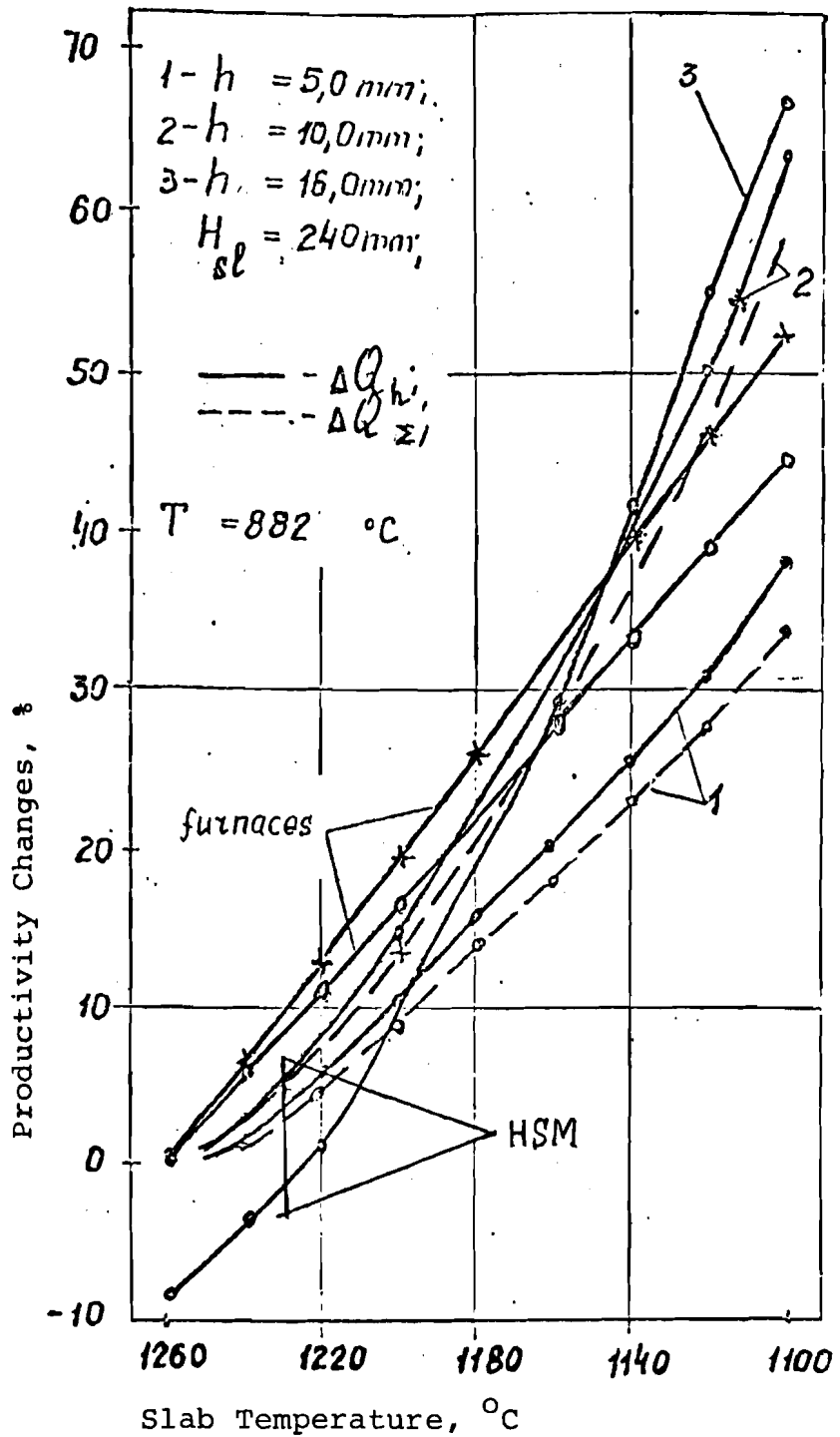

Figure 5.3. Dependence of productivity changes of slab-heating furnace on slab temperature.

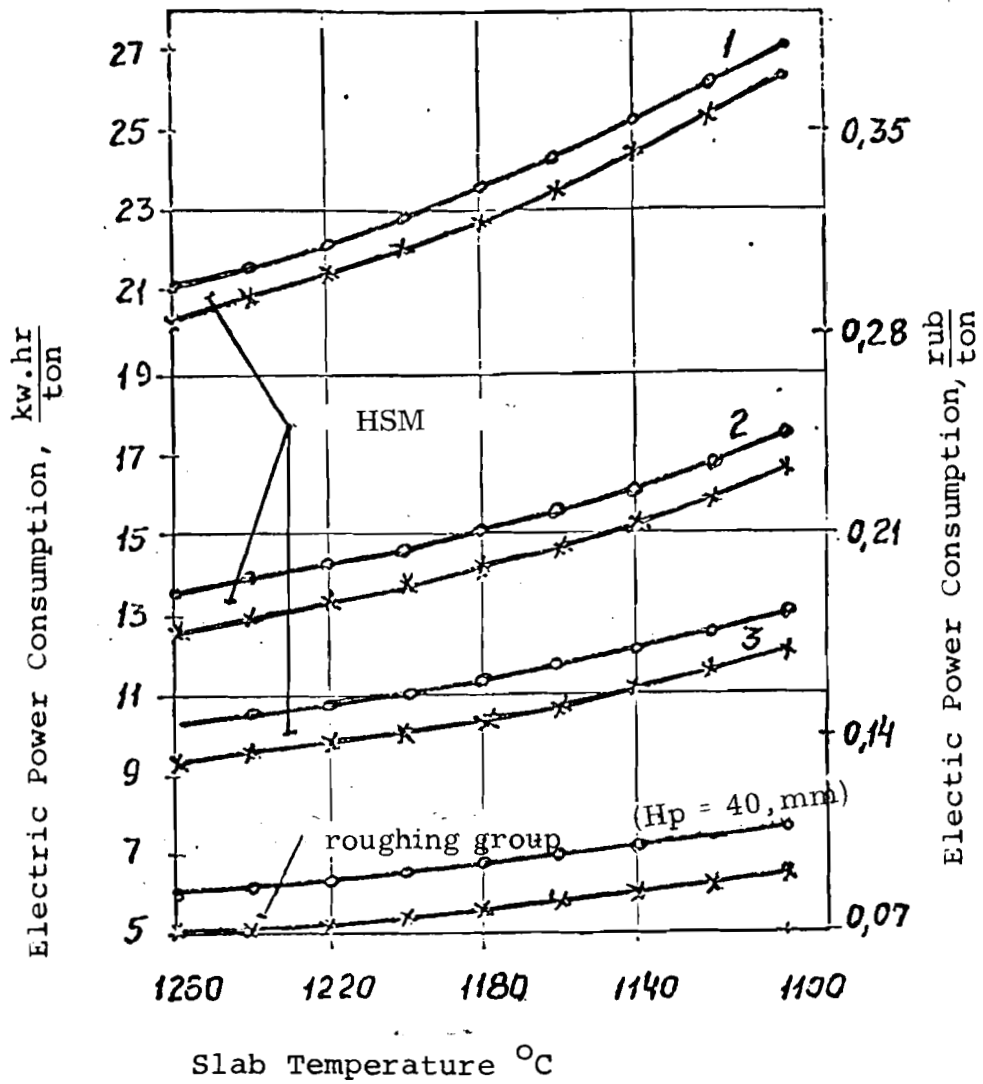

Figure 5.4. Dependence of electric power consumption vs. slab temperature and strip size:

- 1 5.0 x 1750 mm;
- 2 10.0 x 1750 mm;
- 3 16.0 x 1750 mm;
- $H_p = 40$ mm;
- 0 $H_{s1} = 240$ mm;
- X $H_{s1} = 180$ mm.

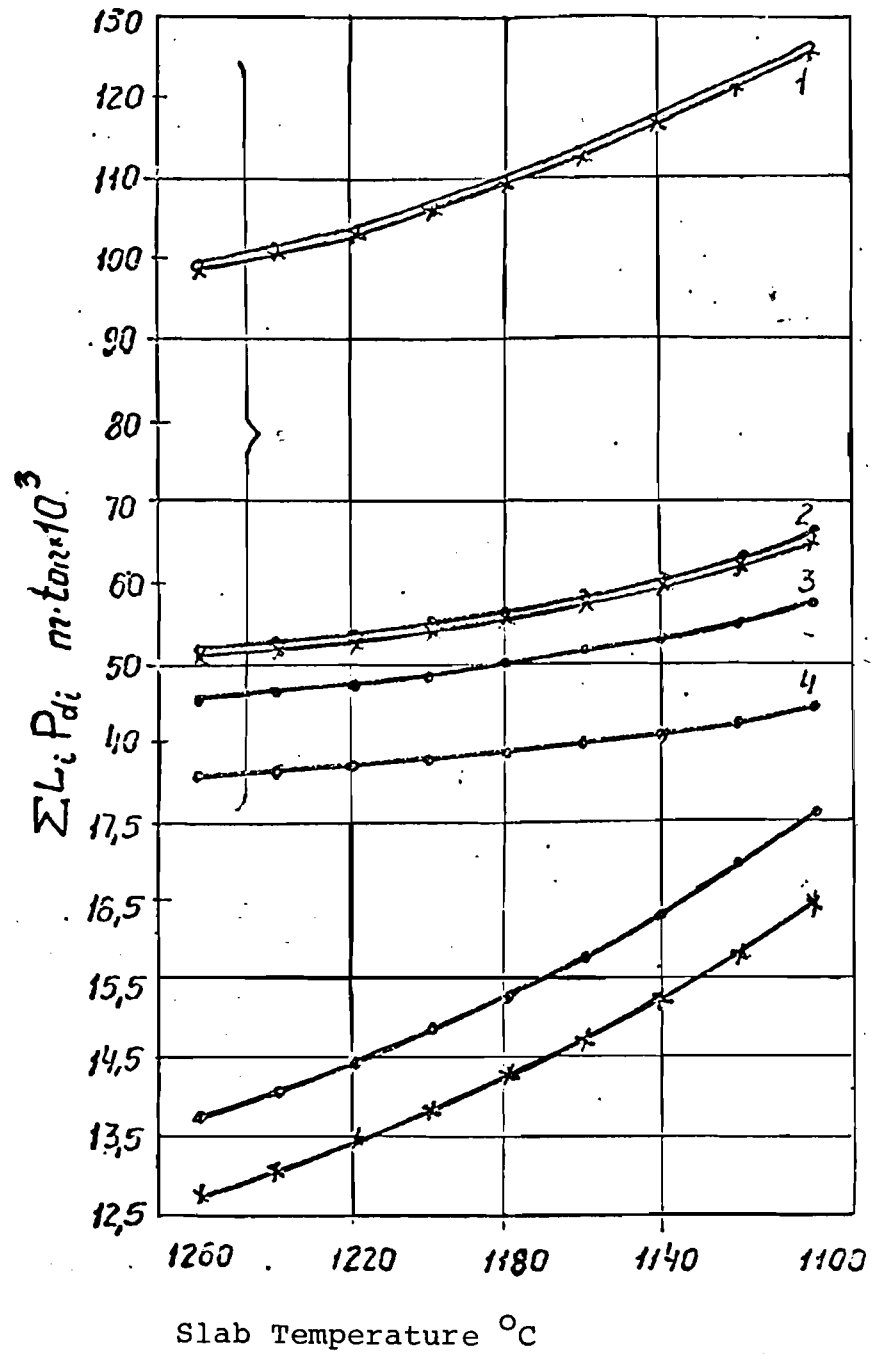

Figure 5.5. Dependence of roll wear on slab temperature and strip size:

- 1 5.0 x 1750 mm;
- 2 10.0 x 1750 mm;
- 3 12.0 x 1750 mm;
- 4 15.0 x 1750 mm;
- 0 $H_{sl} = 240$ mm;
- X $H_{sl} = 180$ mm.

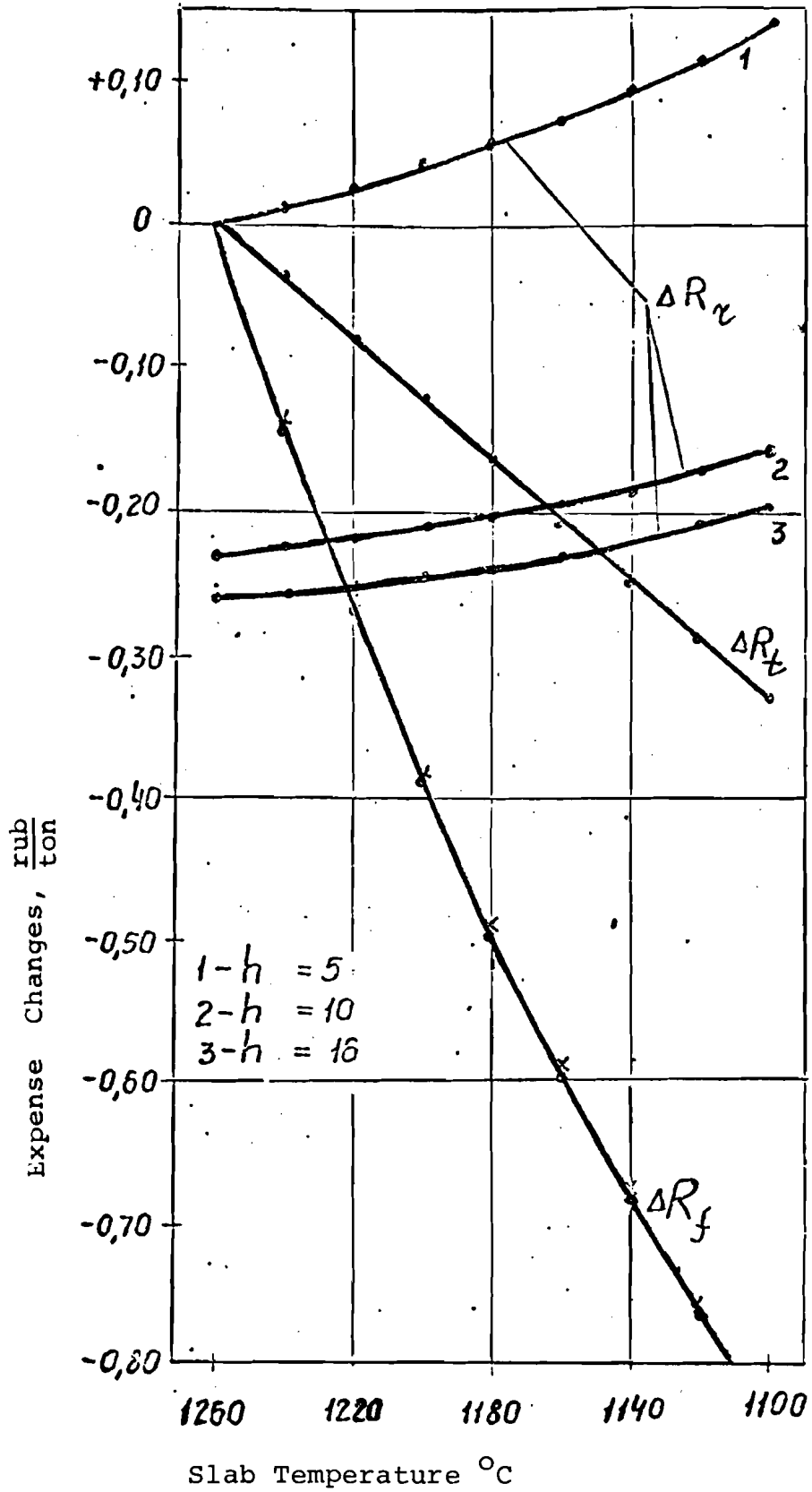

Figure 5.6. Dependence of expenses on slab temperature and strip size.

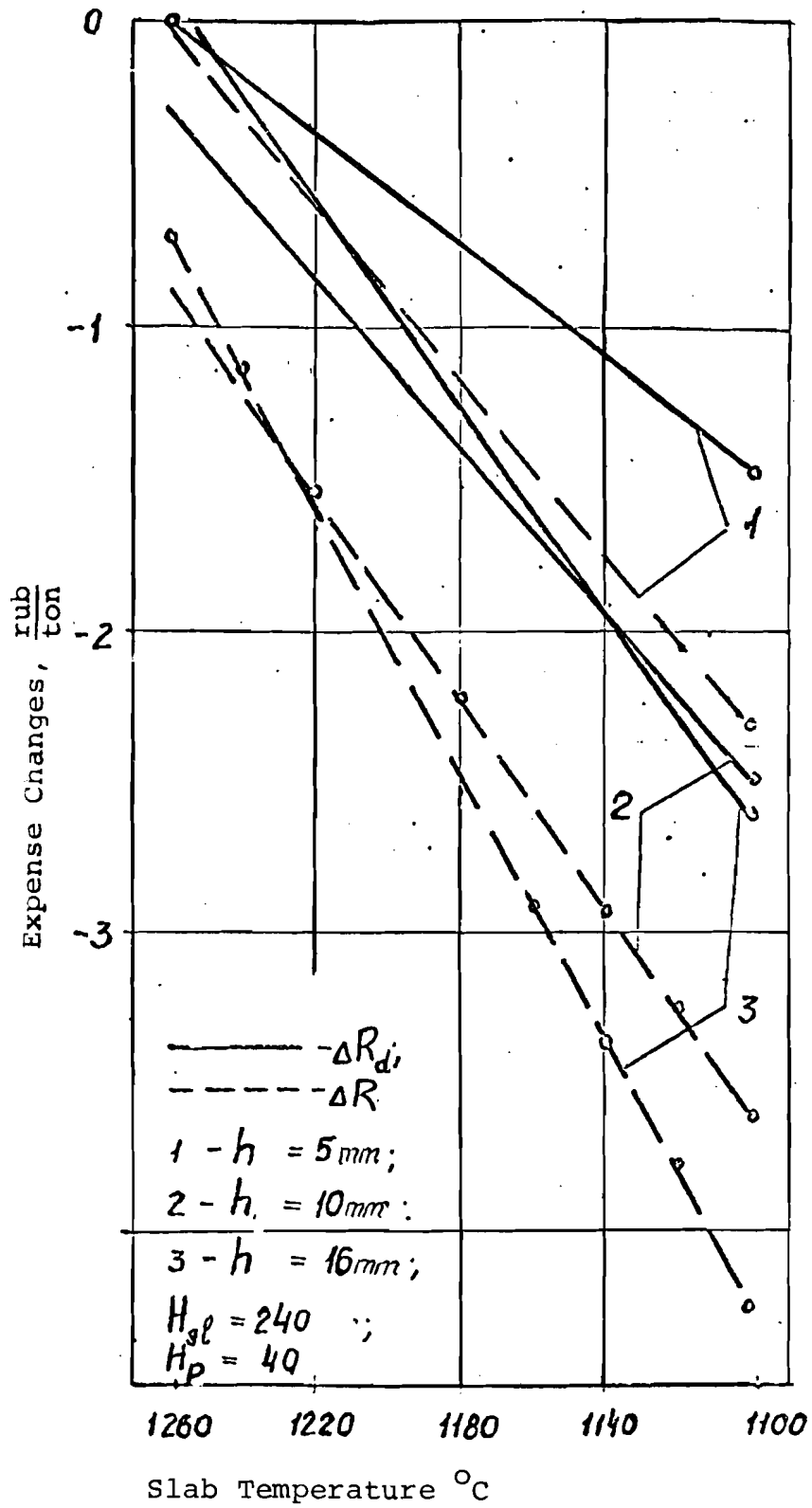

Figure 5.7. Dependence of ΔR and ΔR_d on slab temperature and strip size.

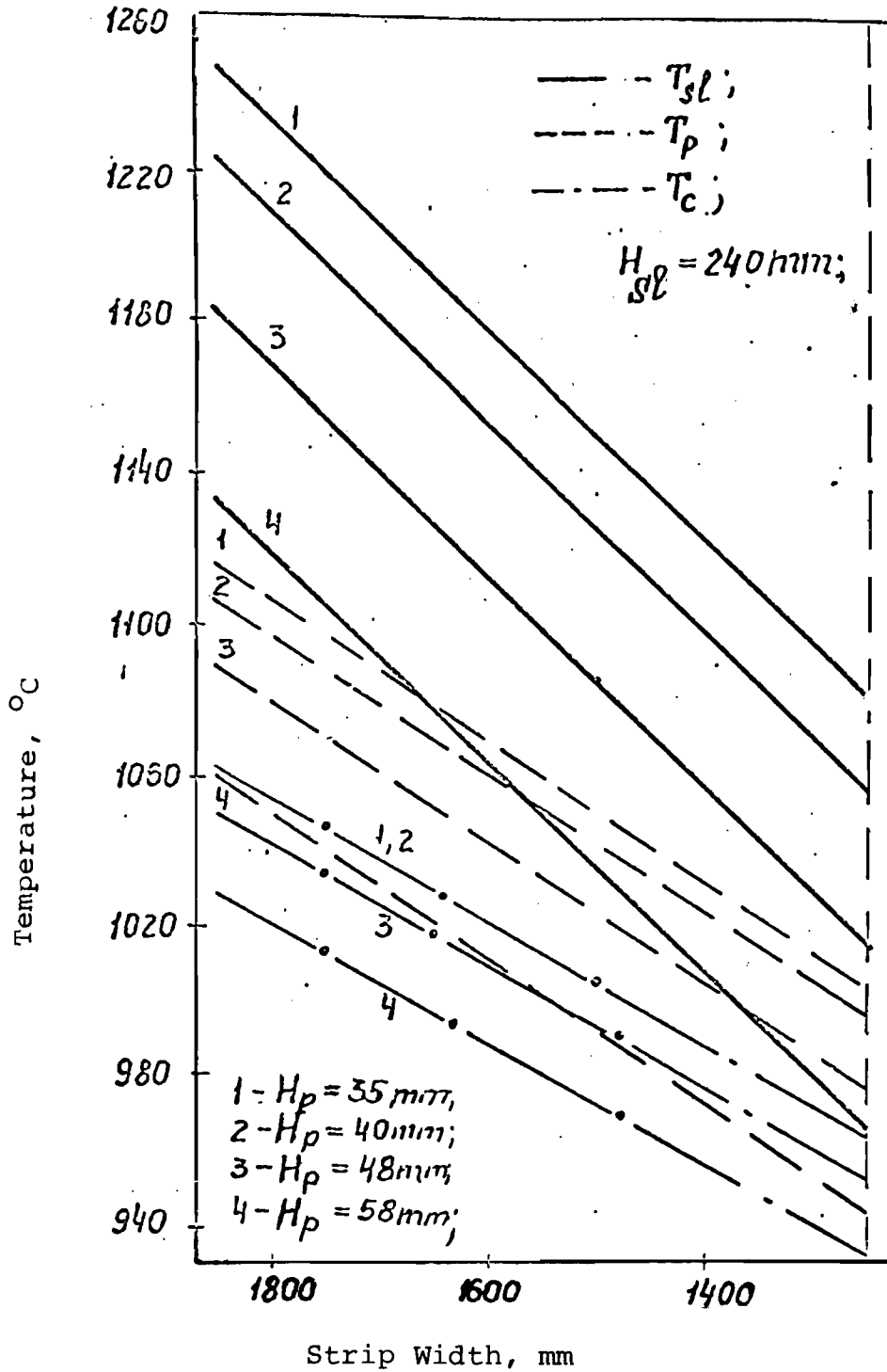

Figure 5.8. Dependence of optimum slab temperature (T_{sl}) and optimum roughed-slab temperature (T_p) on the input of the finishing train vs. roughed-slab width and thickness.

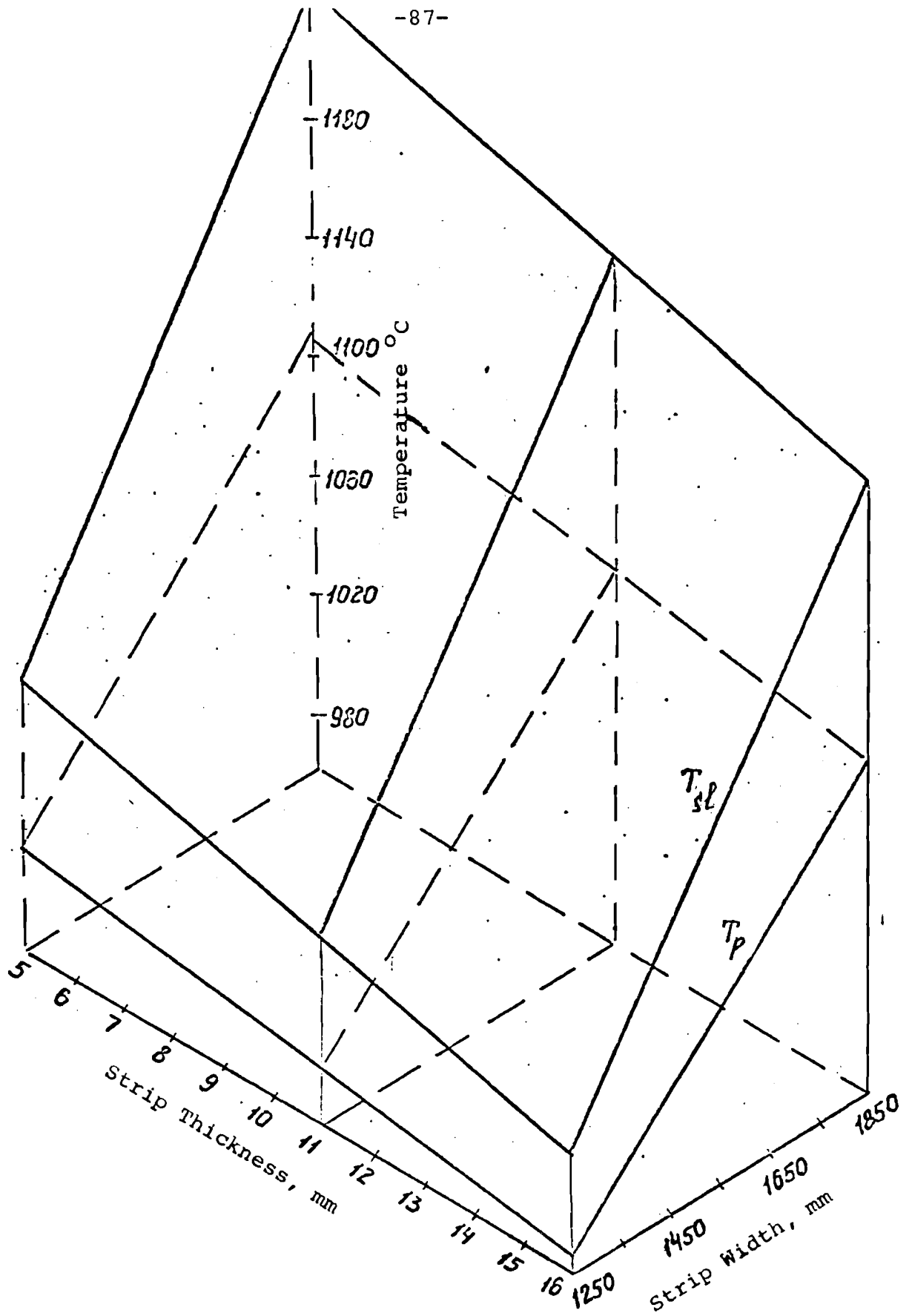

Figure 5.9. Dependence of optimal slab temperature (T_{sl}) and rougher exit metal temperature (T_p) on strip width and thickness ($H_{sl} = 240$ mm).

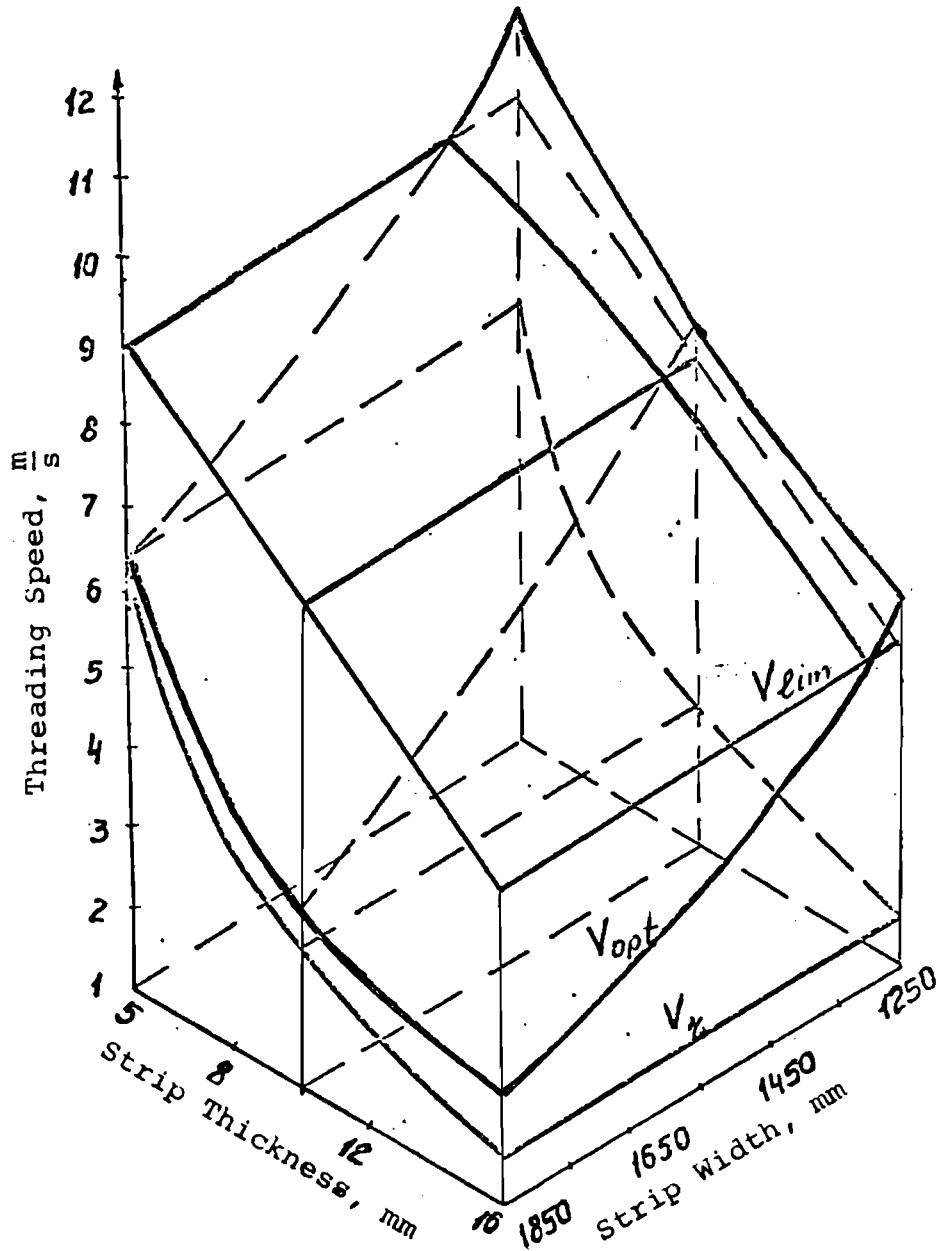

Figure 5.10. Optimal (V_{opt}), allowable (V_{lim}) and practiced (V_z) threading speeds ($H_{s1} = 240$ mm).

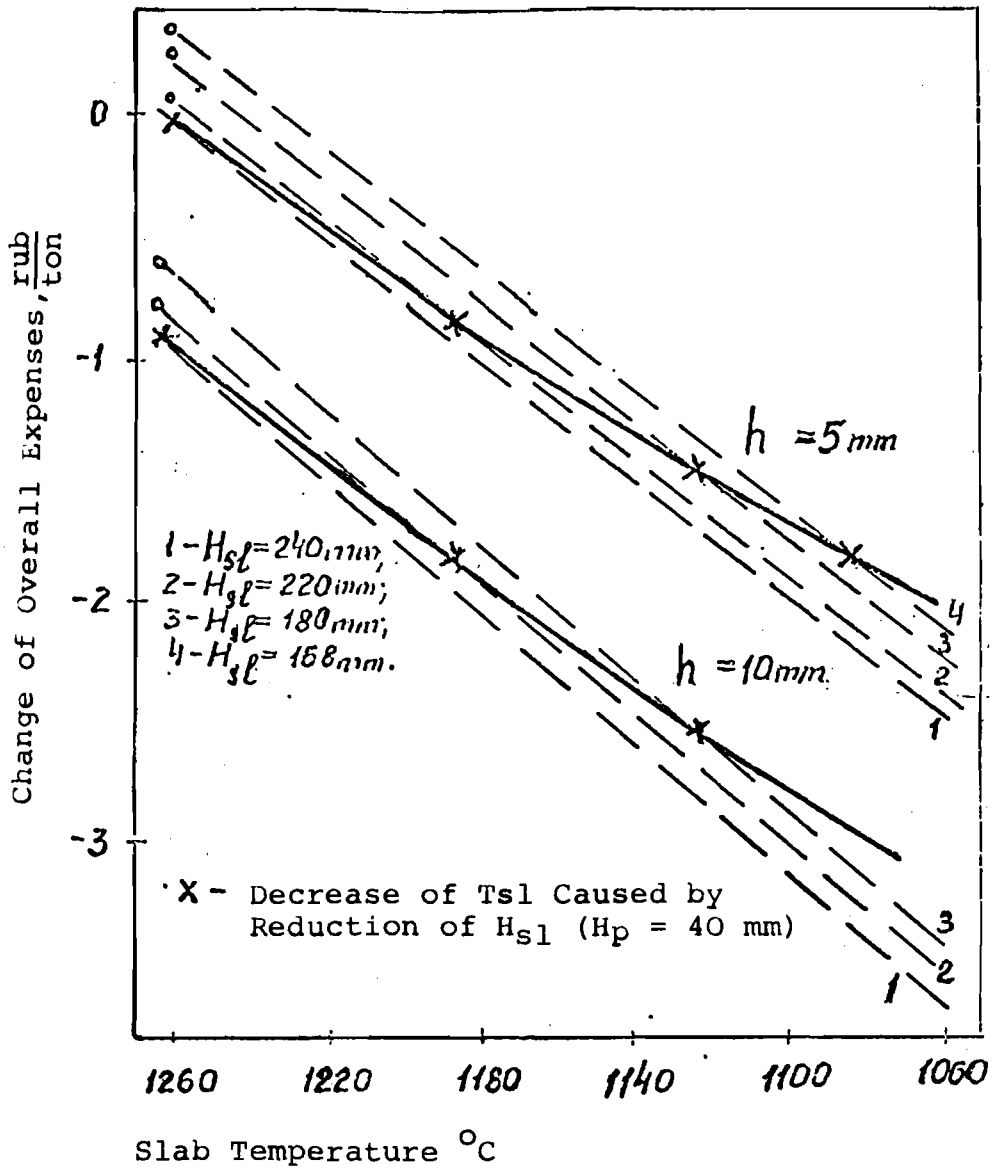

Figure 5.11. Change of overall expenses vs. slab temperature.

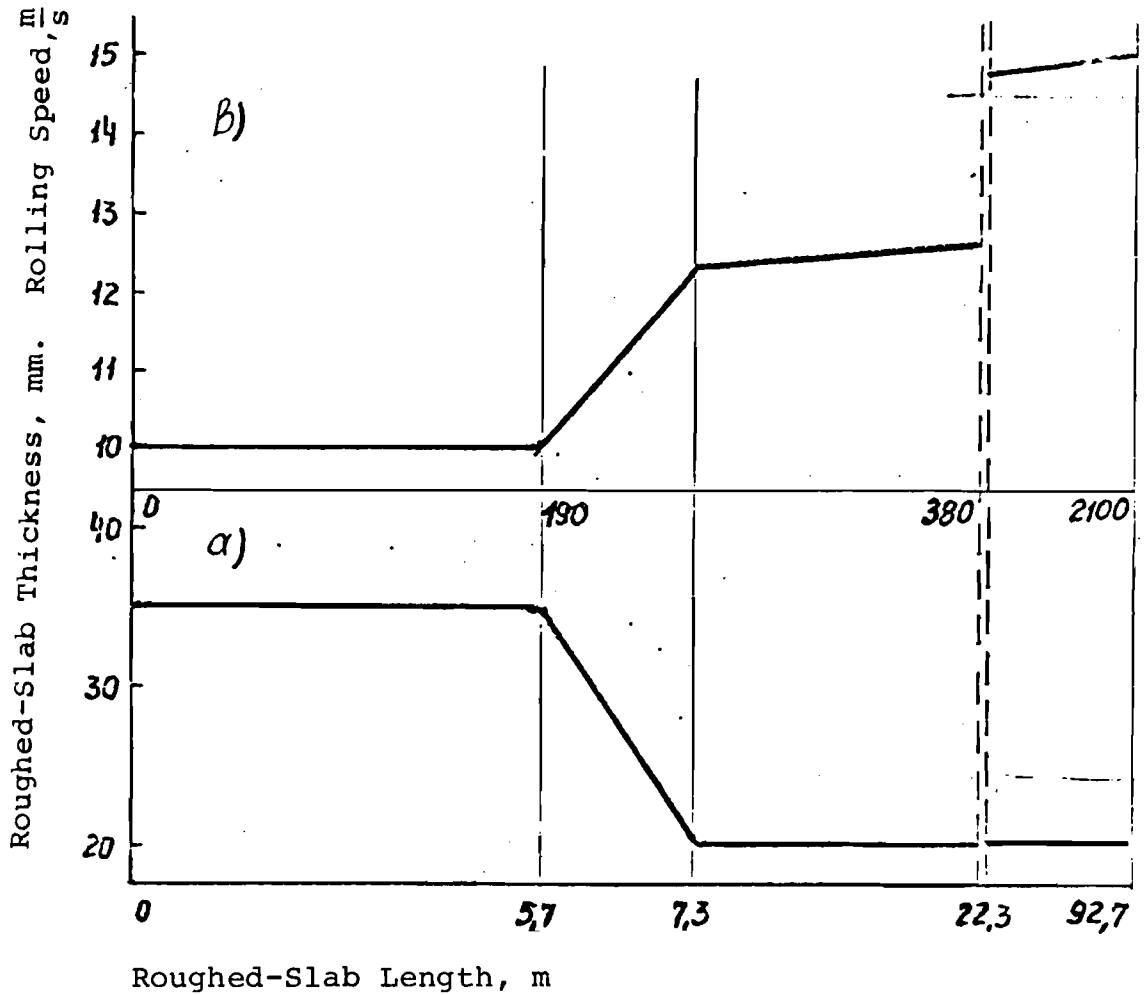

Figure 5.12. a) Roughed-slab thickness along its length;
b) Rolling speed pattern along the strip length (strip size 1.2 x 1250 mm, acceleration 0.5 m/s²).

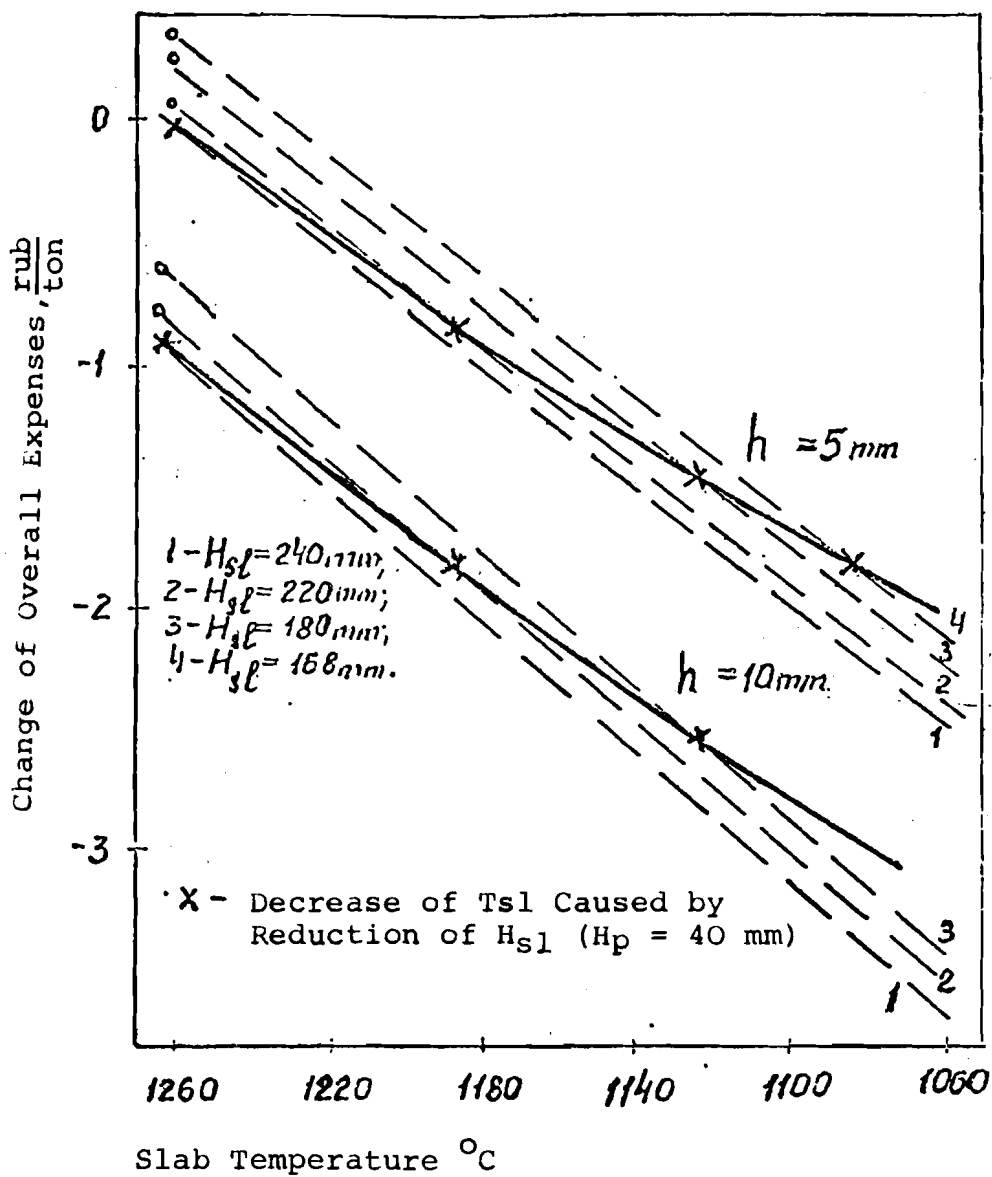

Figure 5.11. Change of overall expenses vs. slab temperature.

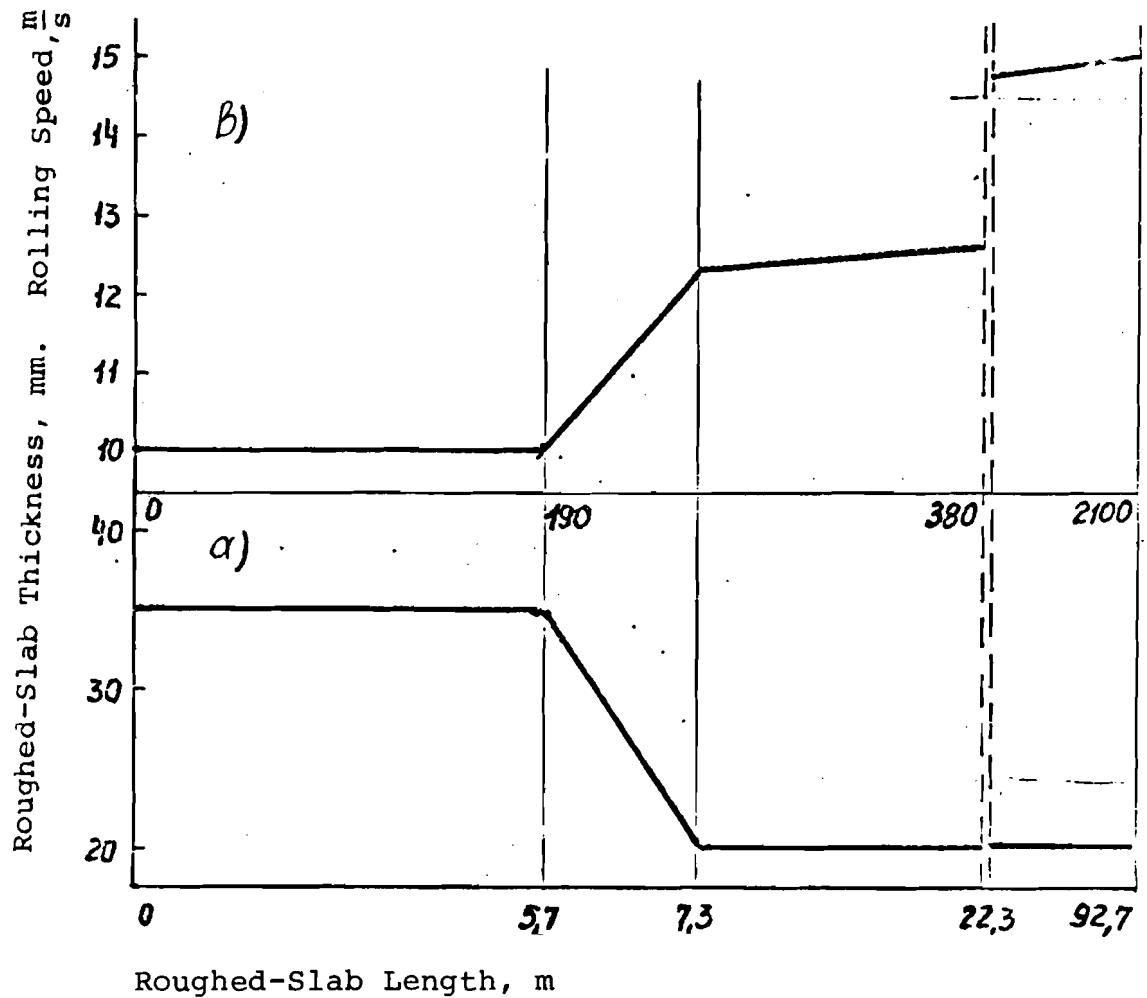
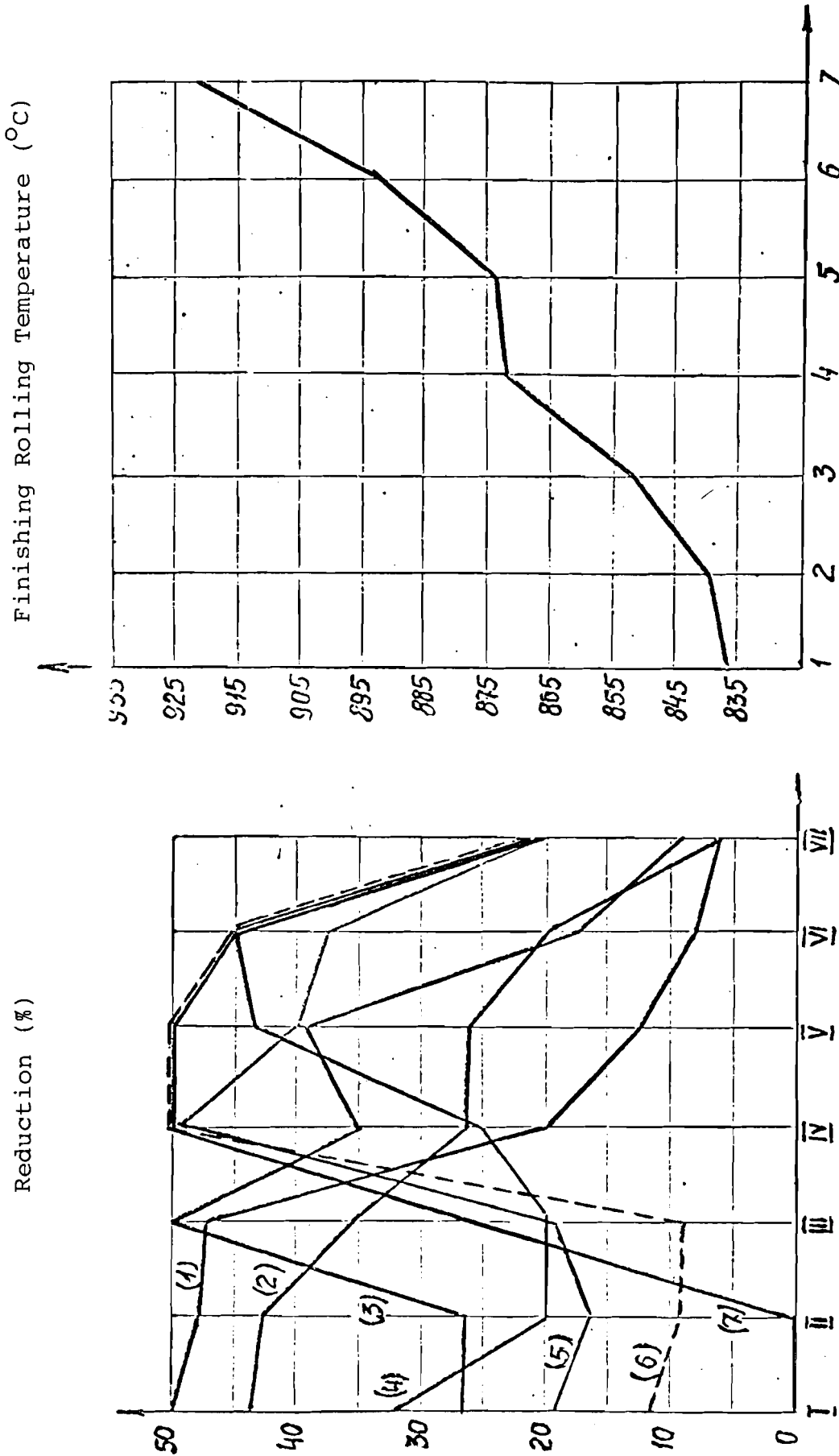

Figure 5.12. a) Roughed-slab thickness along its length;
b) Rolling speed pattern along the strip length (strip size 1.2 x 1250 mm, acceleration 0.5 m/s^2).



a)

b)

Figure 5.13. Reduction distribution (a) and finishing rolling temperature (b) (strip size 3.0 x 1050 mm, threading speed 8.85 $\frac{m}{s}$, roughed-slab thickness 37 mm).

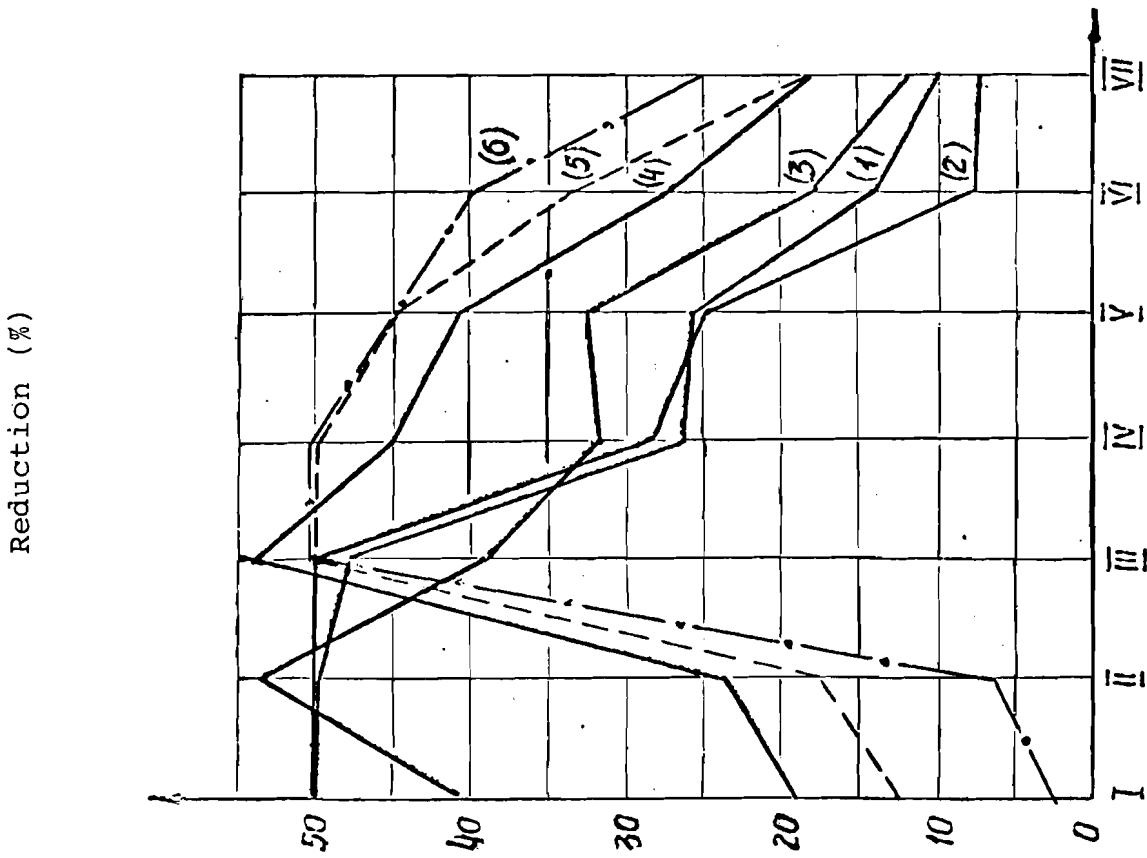
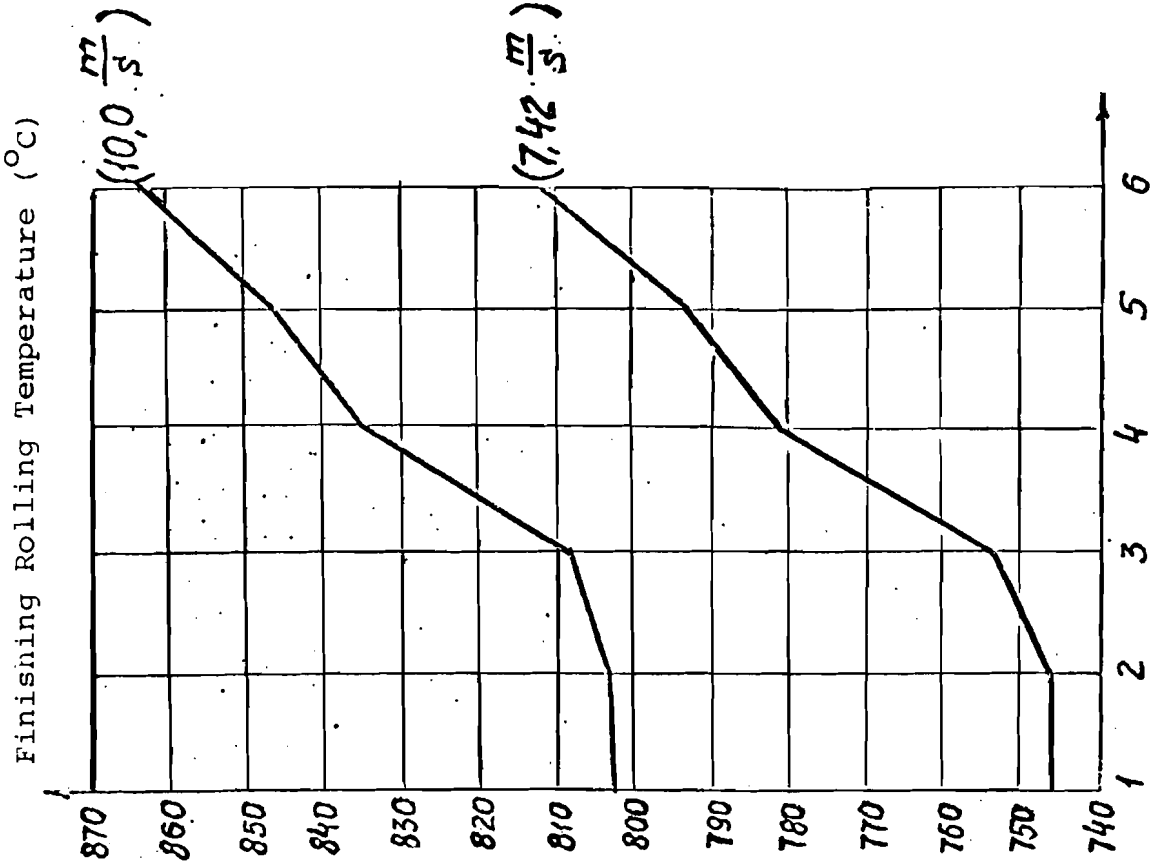

Figure 5.14. Reduction distribution (a) and finishing rolling temperature (b) (strip size 1.8 x 1050 mm, threading speed 7.42 $\frac{\text{m}}{\text{s}}$, 10 $\frac{\text{m}}{\text{s}}$, roughed-slab thickness 37 mm).

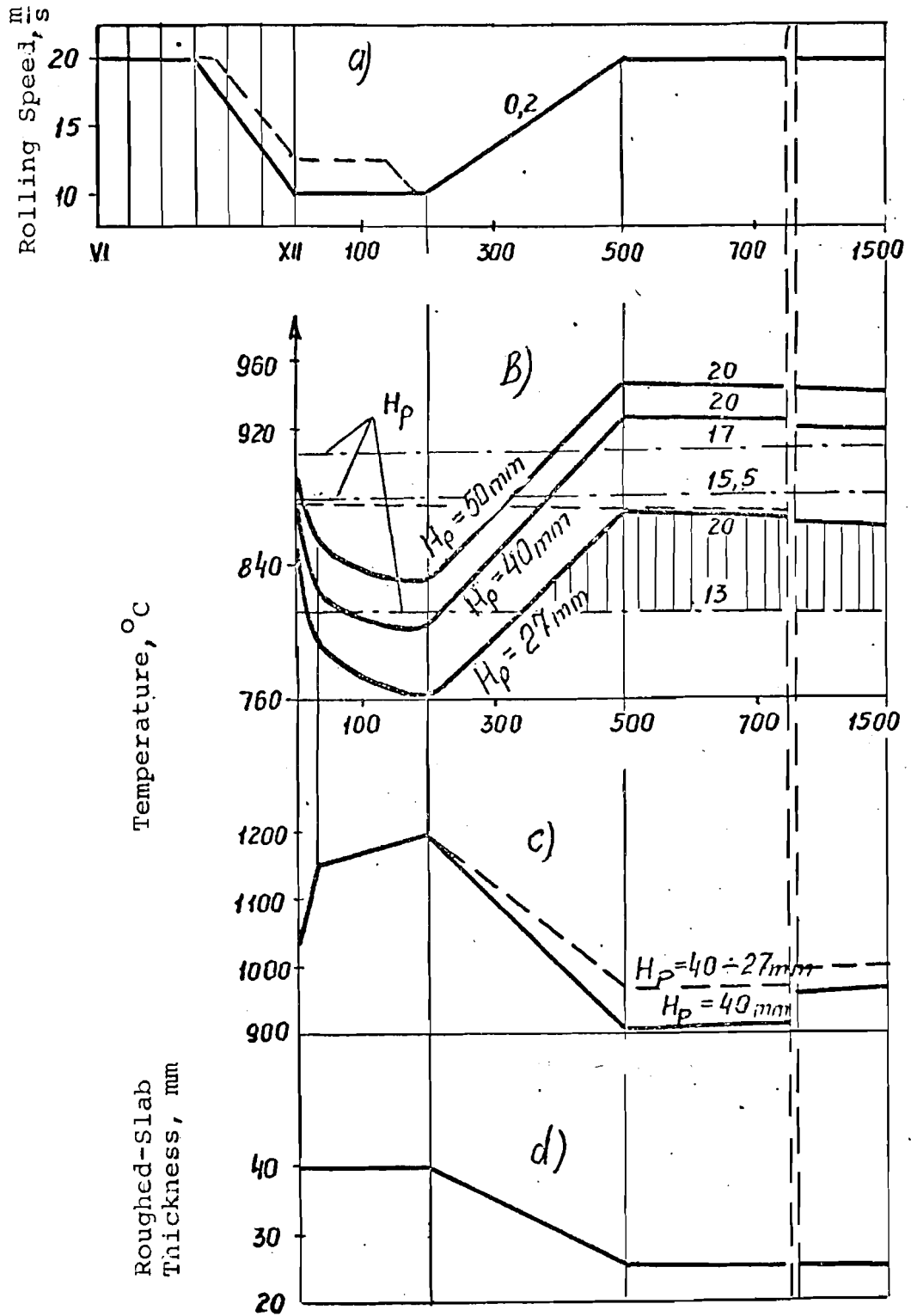

Figure 5.15. Finishing rolling speed (a), temperature distributions along the strip length (b), temperature distribution along the roughed-slab length (c), roughed-slab thickness (d) (strip size 1.5 x 1250 mm, 2000 mill).

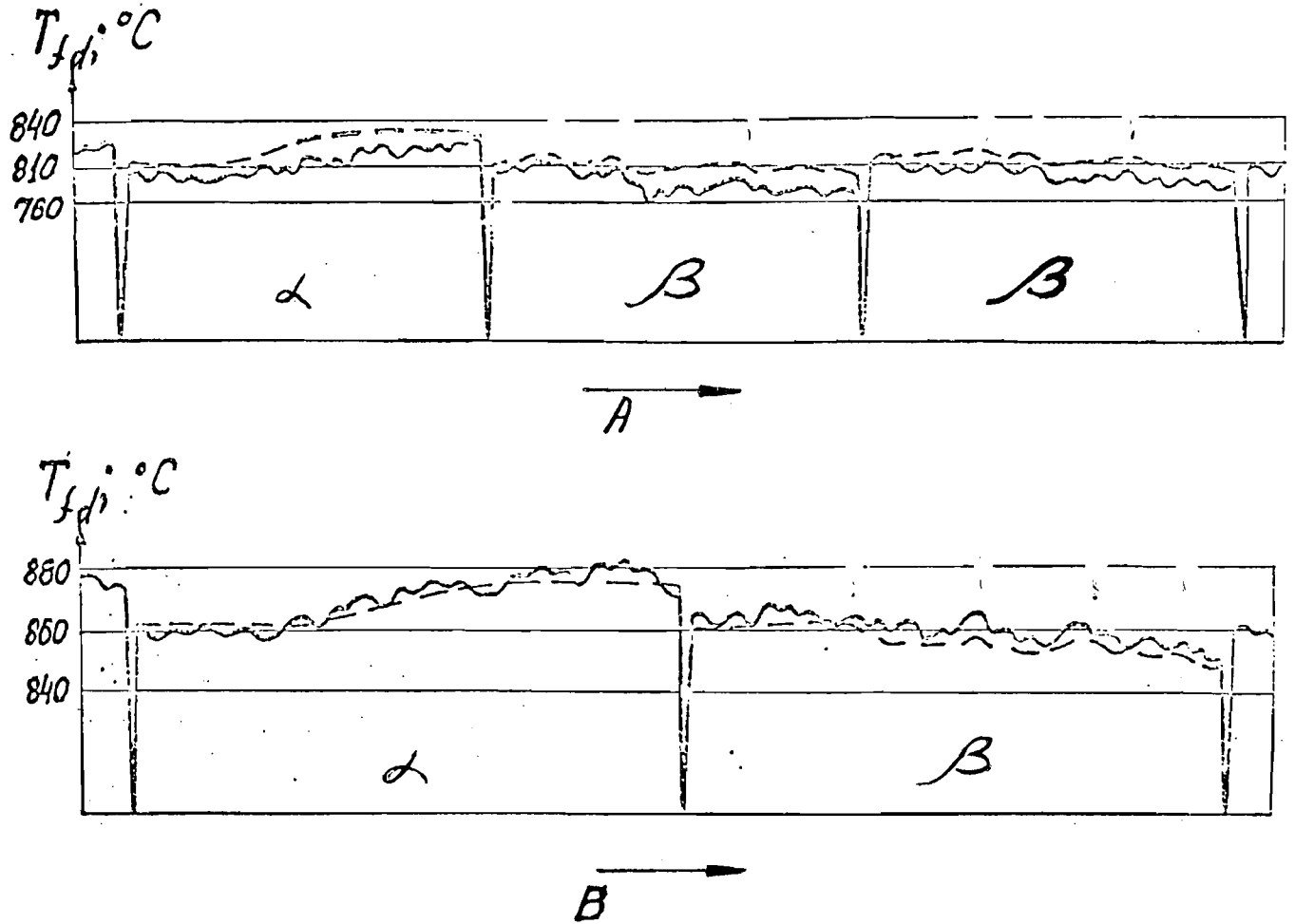

Figure 5.16. Change of finishing rolling temperature along the strip length:

A - Strip size 2.0 x 1050 mm, $V_b = 9.4$ m/s,
 $a = 0.039$ m/s².

B - Strip size 3.0 x 1000 mm, $V_b = 8.2$ m/s,
 $a = 0.064$ m/s².

The curves were obtained in the experiment (—) and with the mathematical model (----);
 α - without strip inter-stand cooling;
 β - with strip inter-stand cooling.

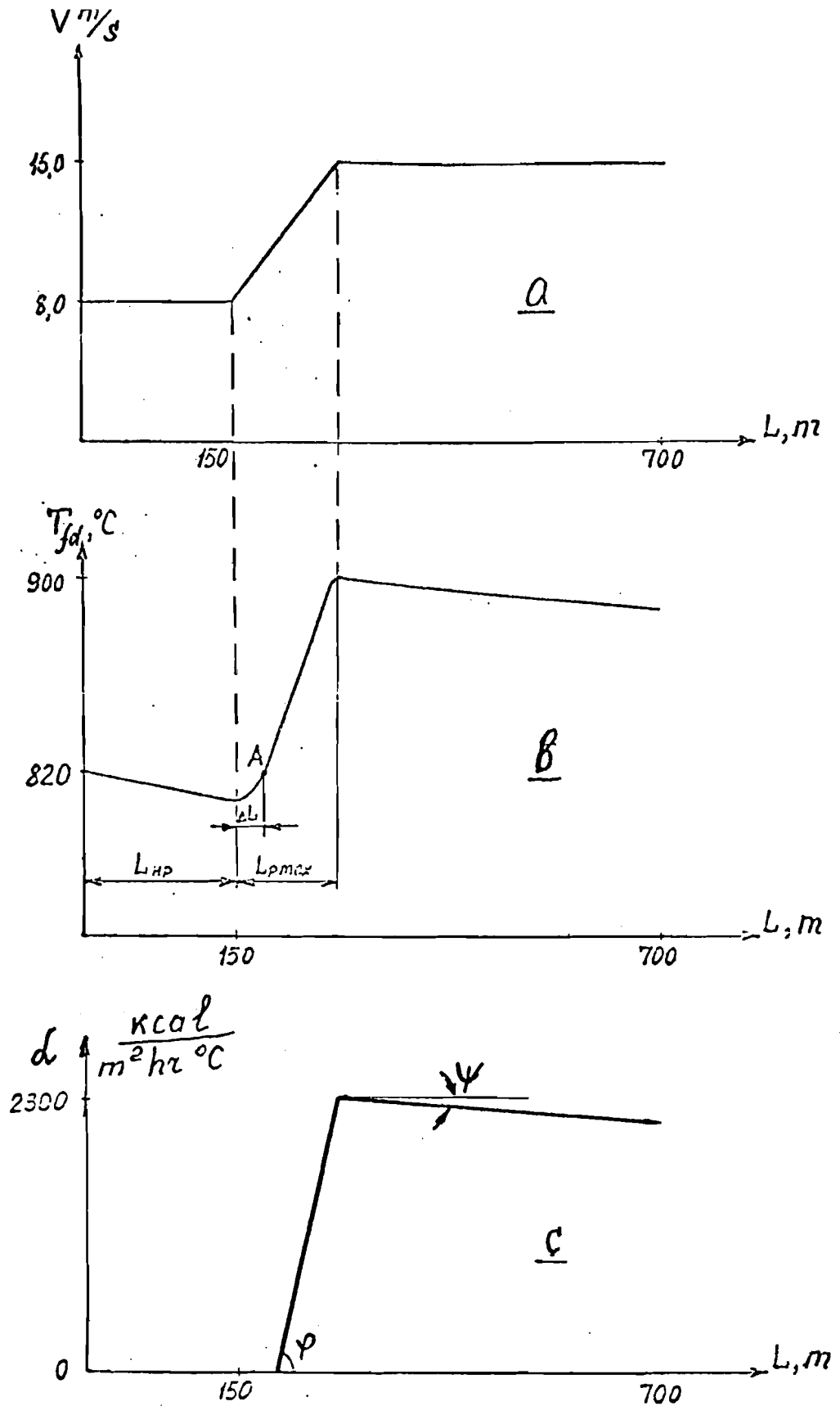

Figure 5.17. Change of rolling speed (a), finishing rolling temperature (b), and transfer coefficient necessary to stabilize T_{fd} along the strip length (c) in rolling with high acceleration.

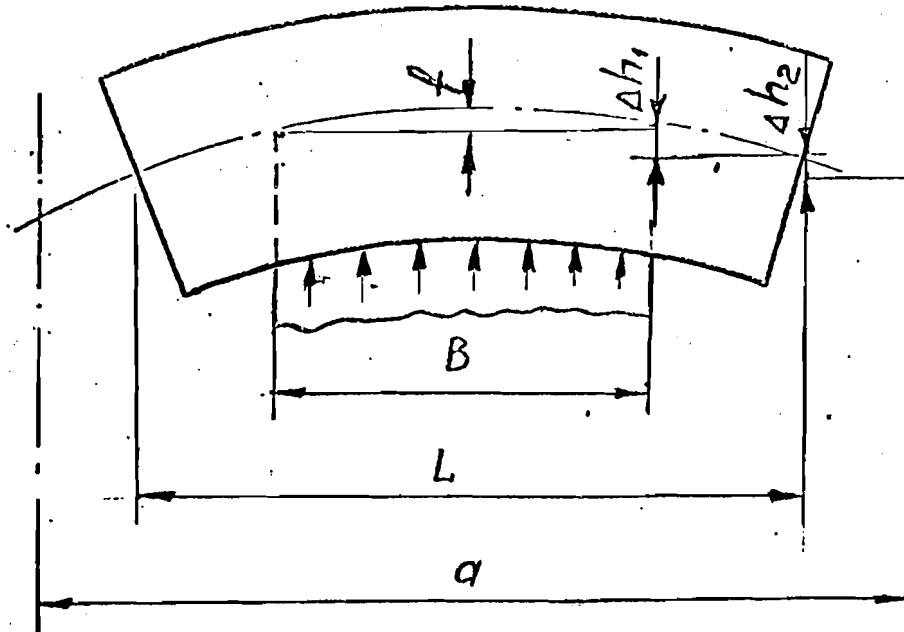

Figure 6.1. Roll bending by the rolling forces.

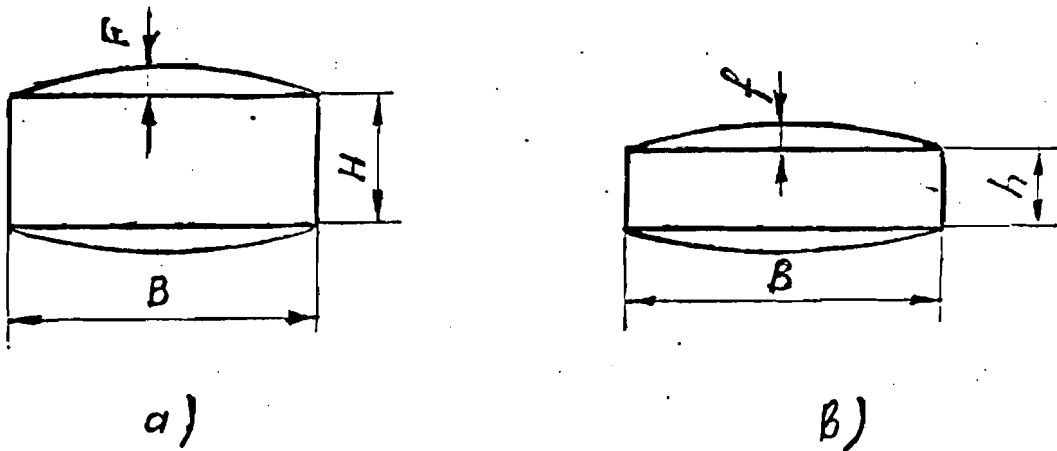

Figure 6.2. Strip cross-section at the stand input (a) and output (b).

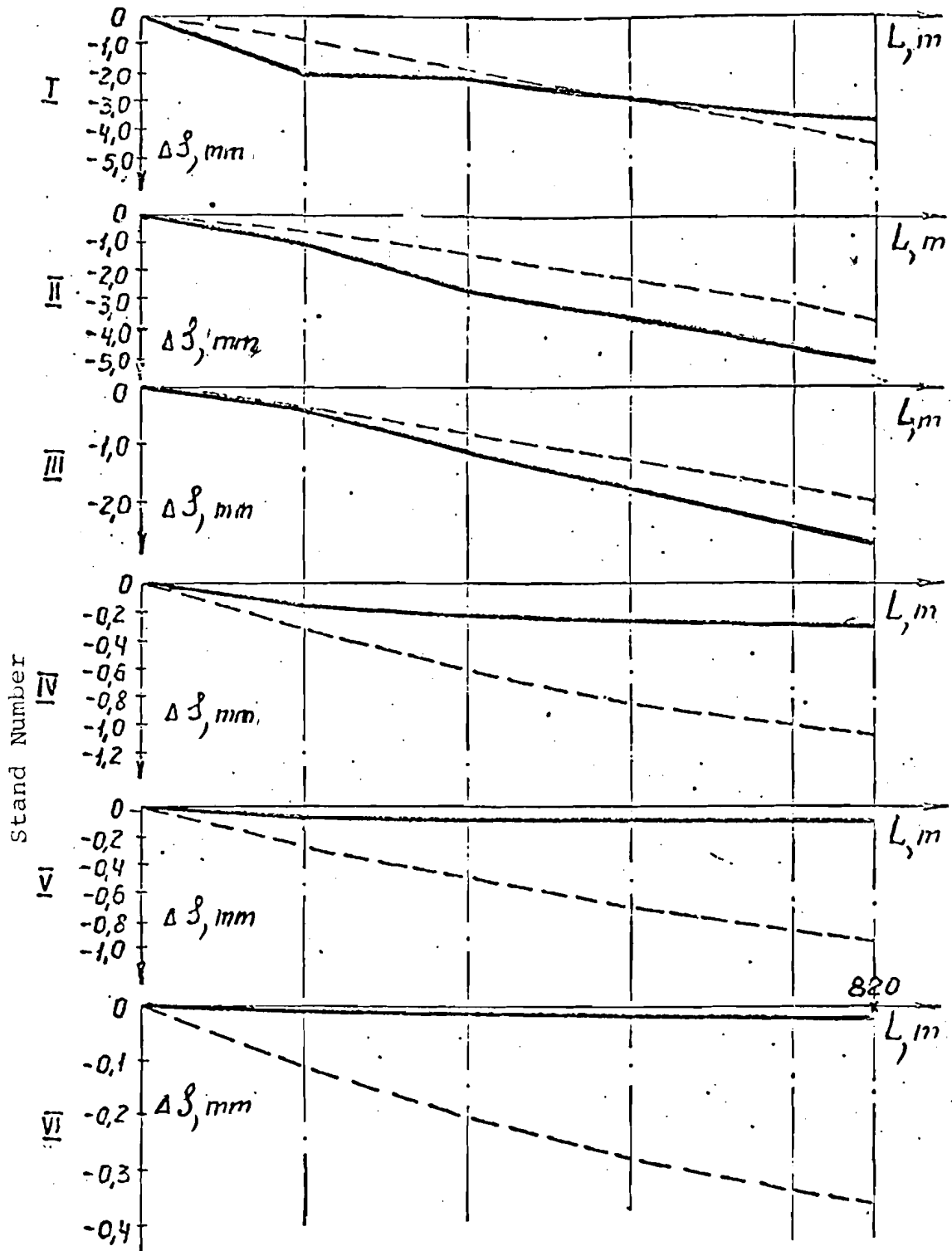

Figure 6.3. Stand screw-down replacements along the strip length caused by the gauge control (strip size 1.2 x 1250 mm)

----- Sims-Golovin method,
———— Proposed method.

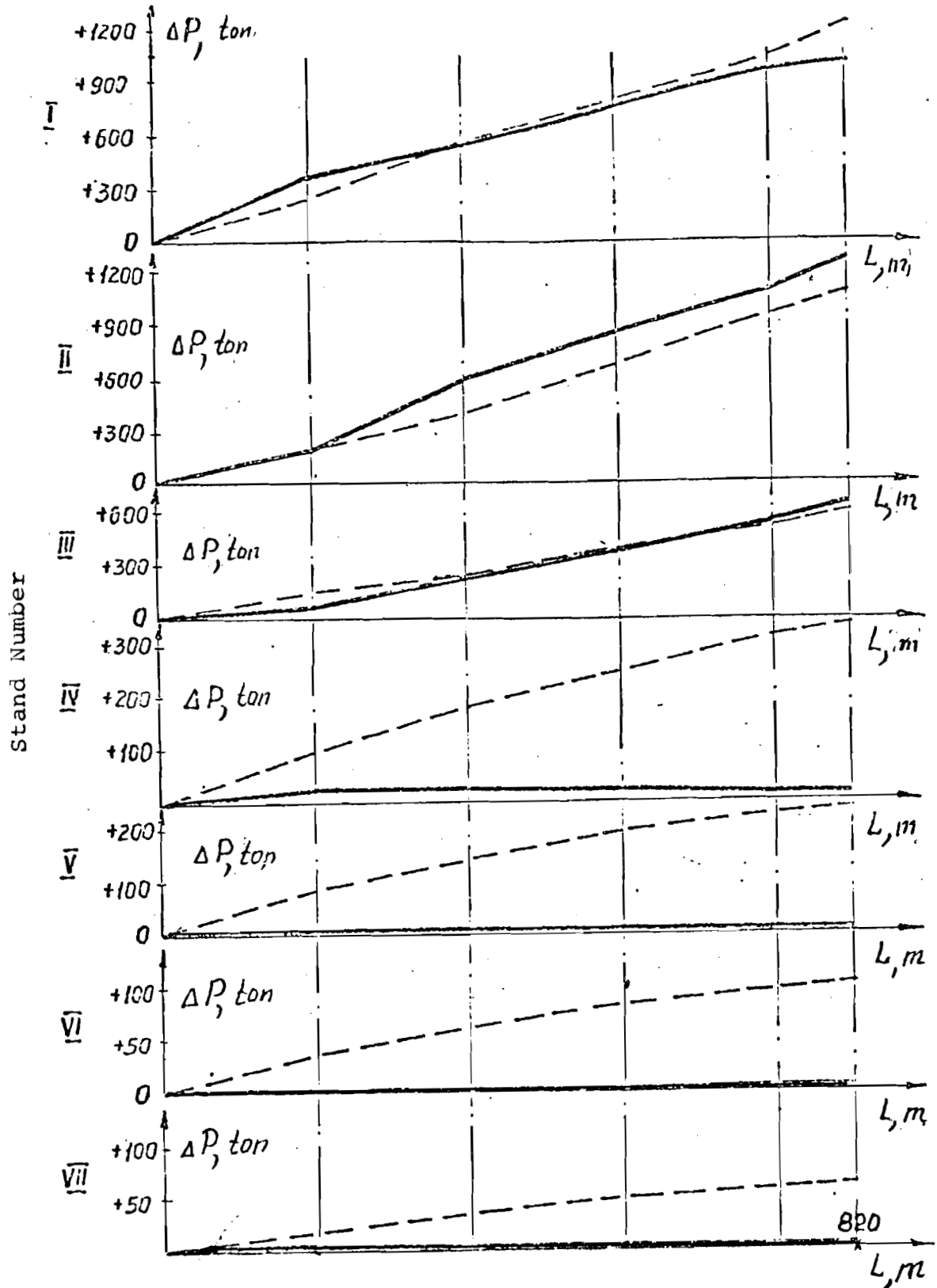

Figure 6.4. Stand load changes along the strip length L caused by the (strip size 1.2 x 1250 mm):

----- Sims-Golovin method,
 ————— Proposed method.

Allowable δ in the finishing stands I - VII are respectively: 0.22; 0.24; 0.025; 0.08; 0.015; 0.008; 0.002 (see formula 6.10).

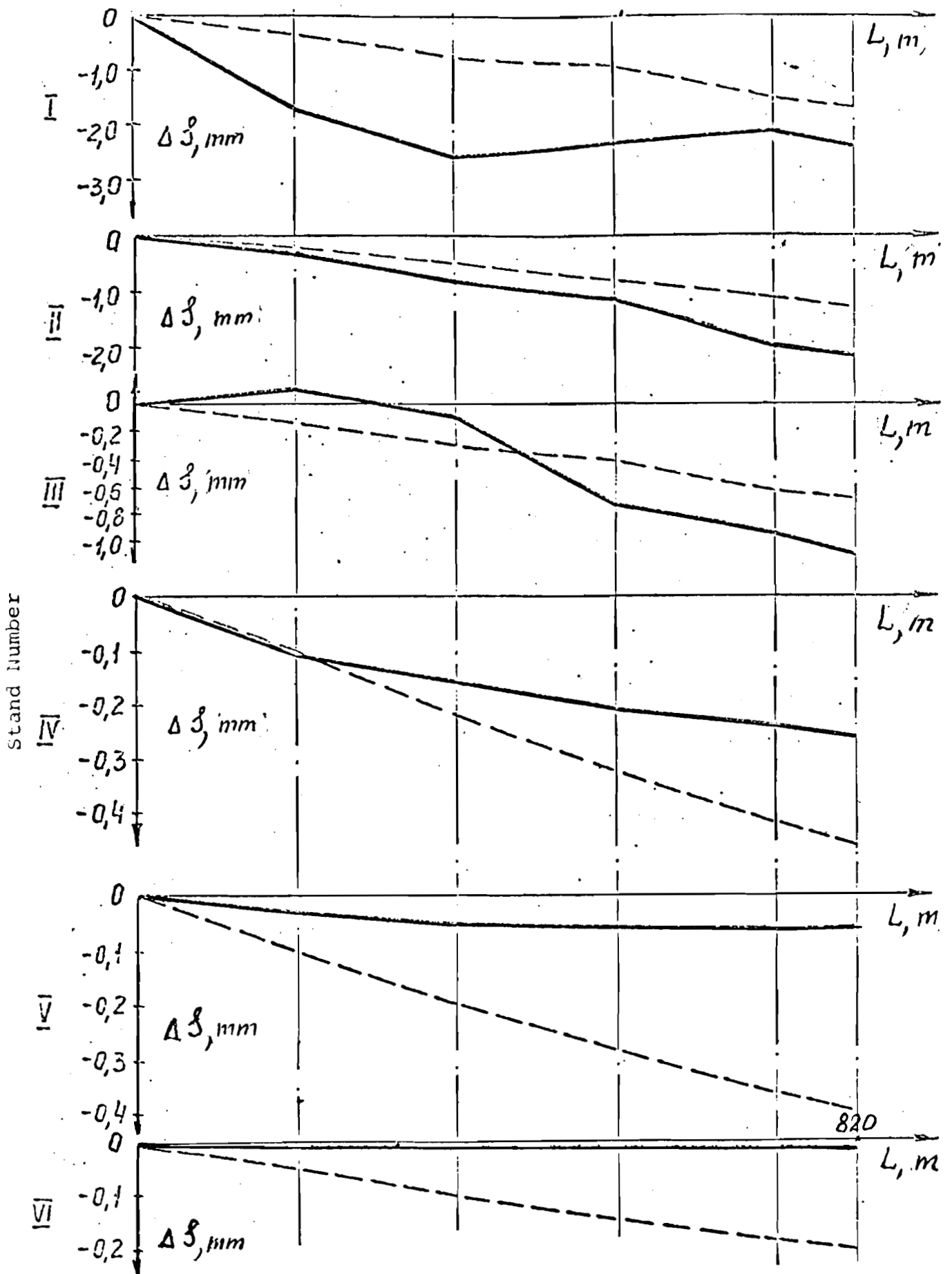

Figure 6.5. Same as Figure 6.3 (strip size 1.6 x 1250 mm).

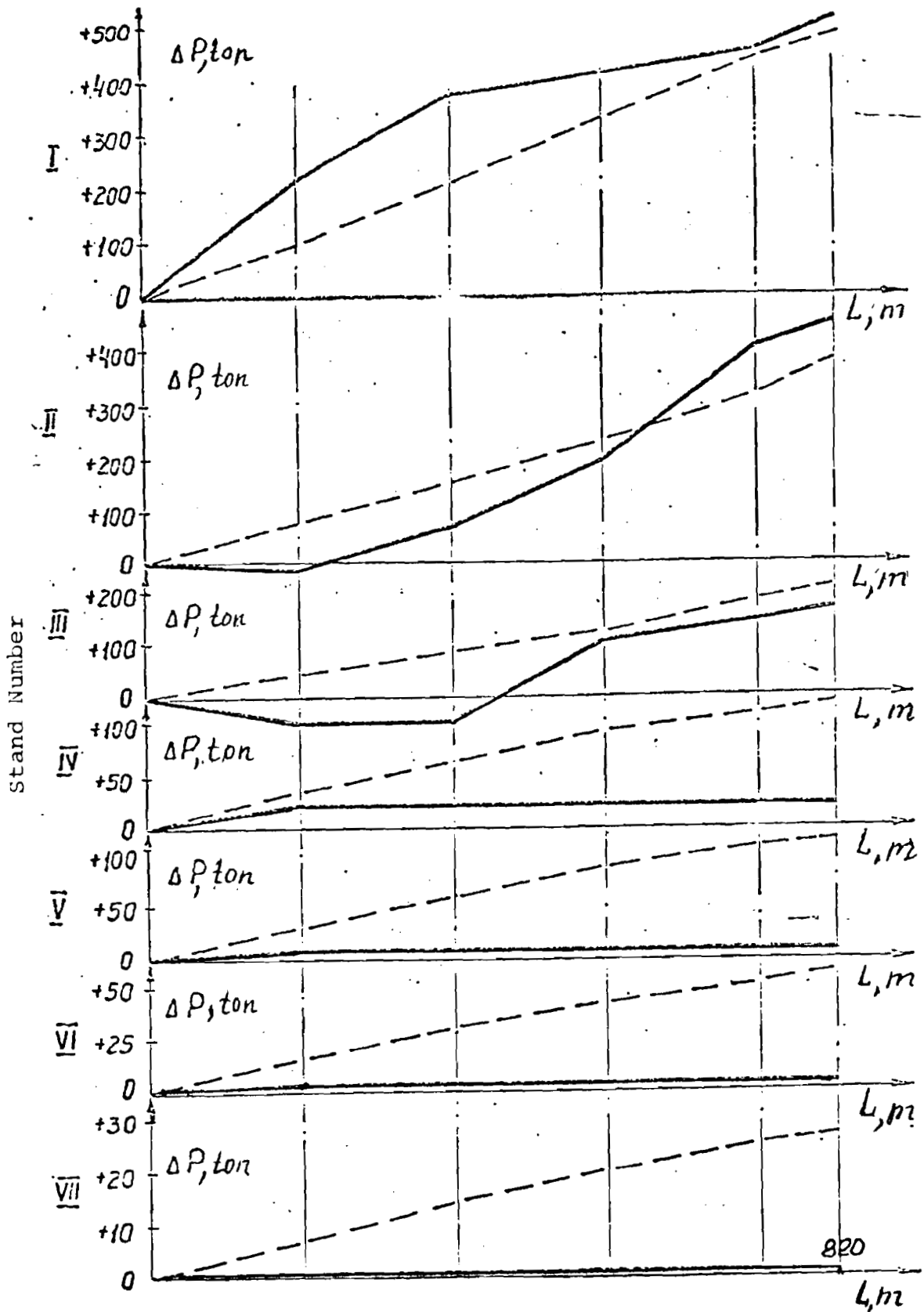

Figure 6.6. Same as Figure 6.4 (strip size 1.2 x 1250 mm); $\delta \rightarrow$ 0.06; 0.053; 0.03; 0.02; 0.0015; 0.008; 0.002.

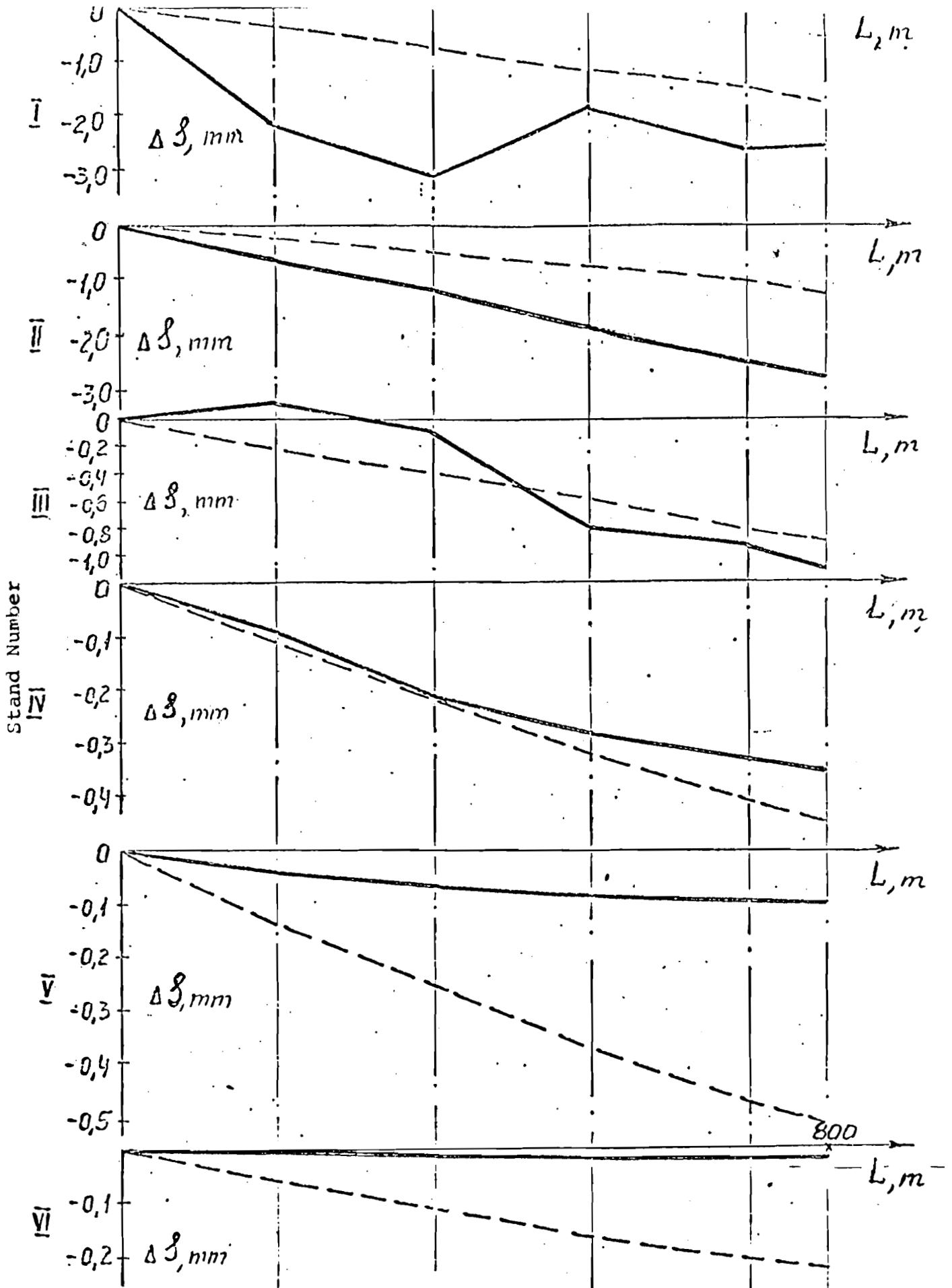

Figure 6.7. Same as Figure 6.3 (strip size 1.8 x 1250 mm).

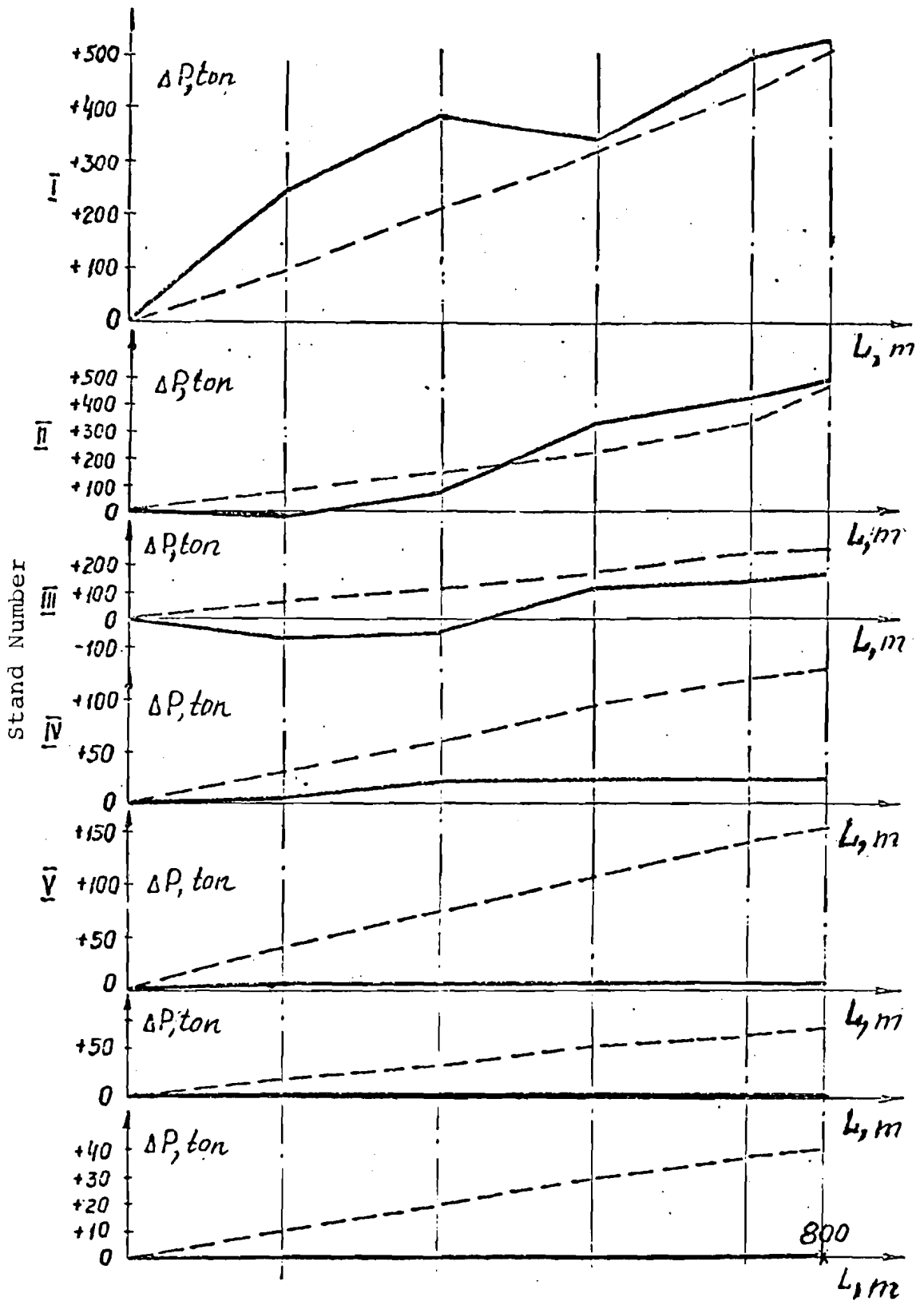

Figure 6.8. Same as Figure 6.6 (strip size 1.8 x 1250 mm).

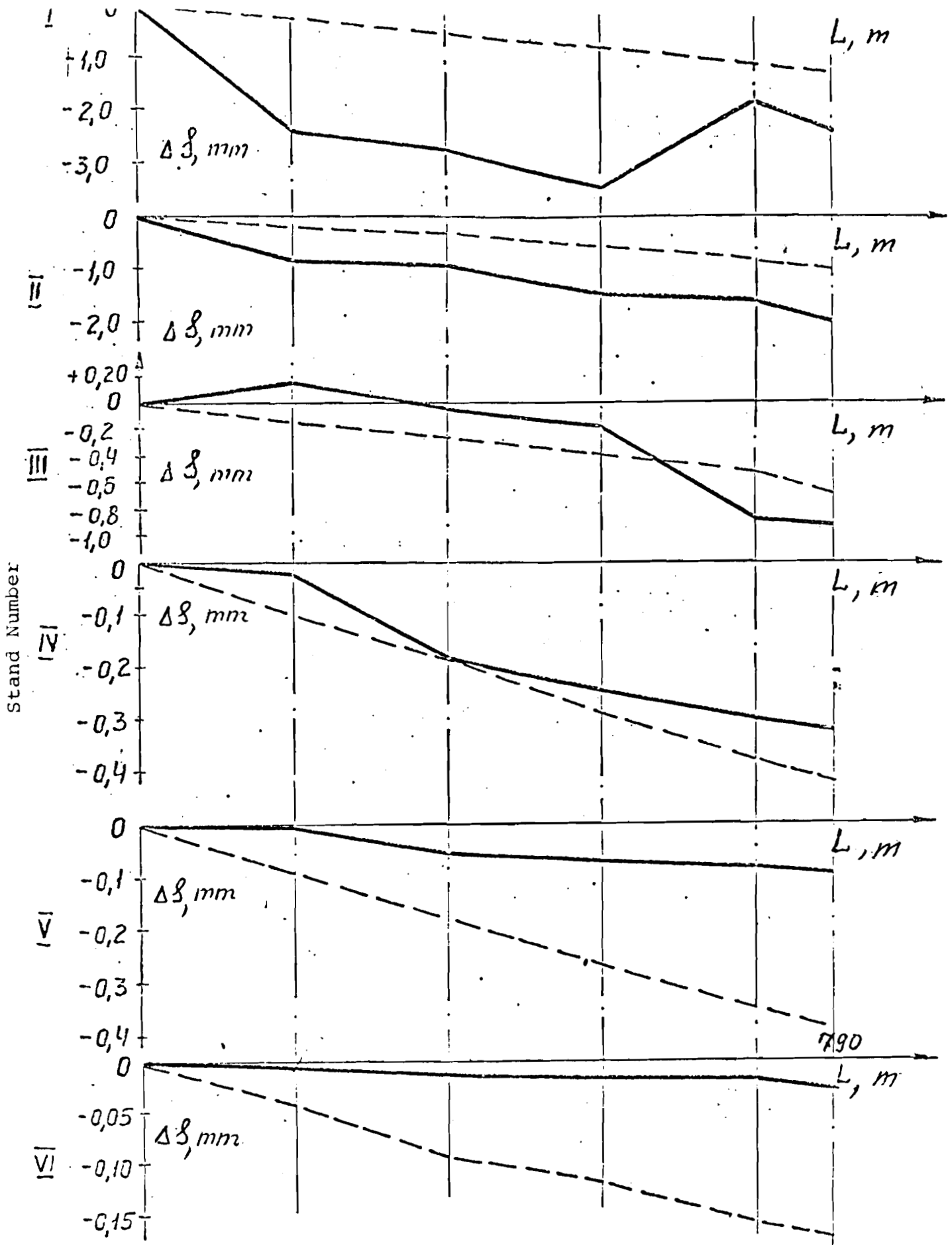

Figure 6.9. Same as Figure 6.3 (strip size 2 x 1250 mm).

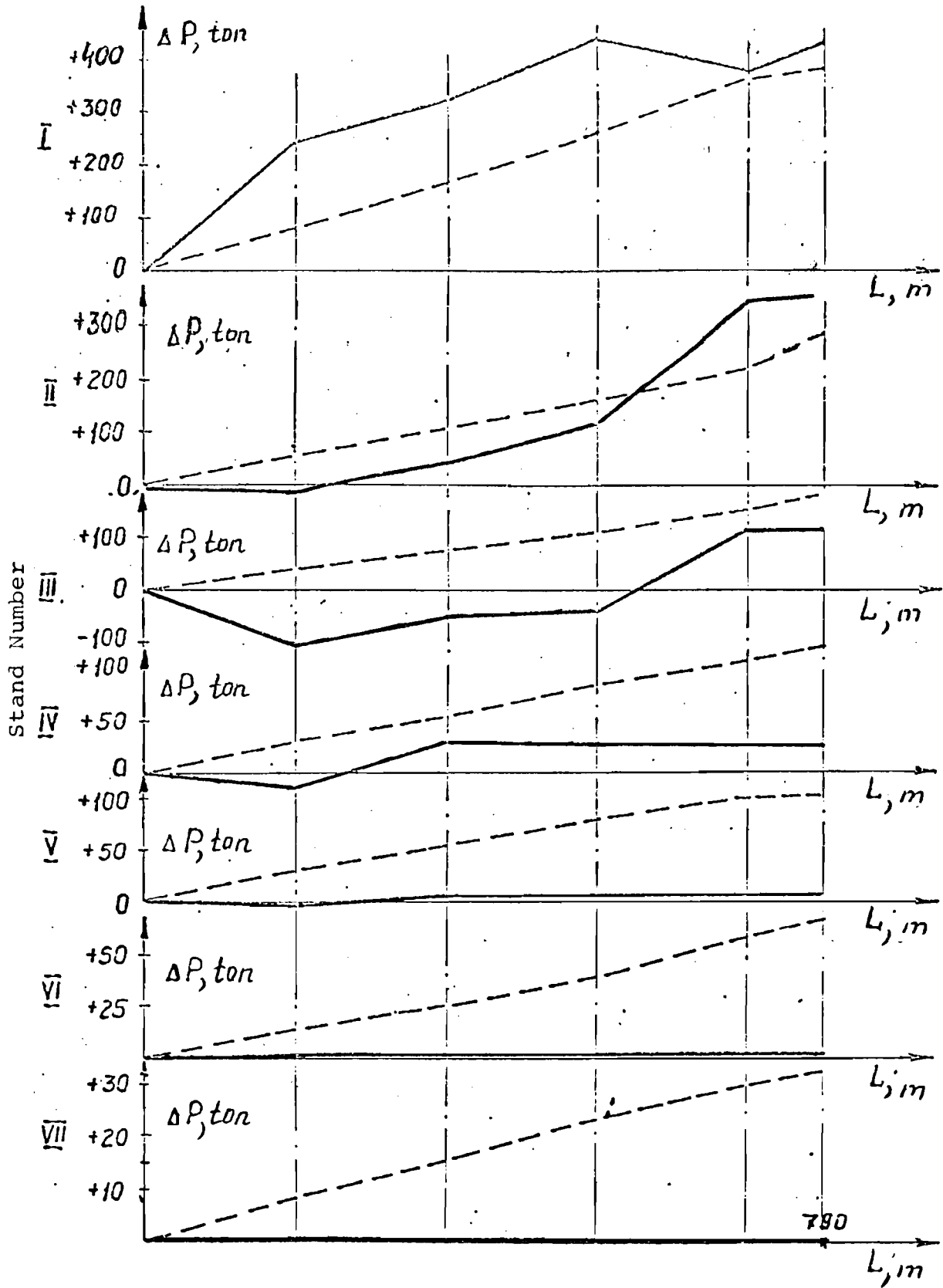

Figure 6.10. Same as Figure 6.4 (strip size 2 x 1250 mm); $\delta \rightarrow 0.03; 0.03; 0.025; 0.011; 0.0015; 0.008; 0.002$.

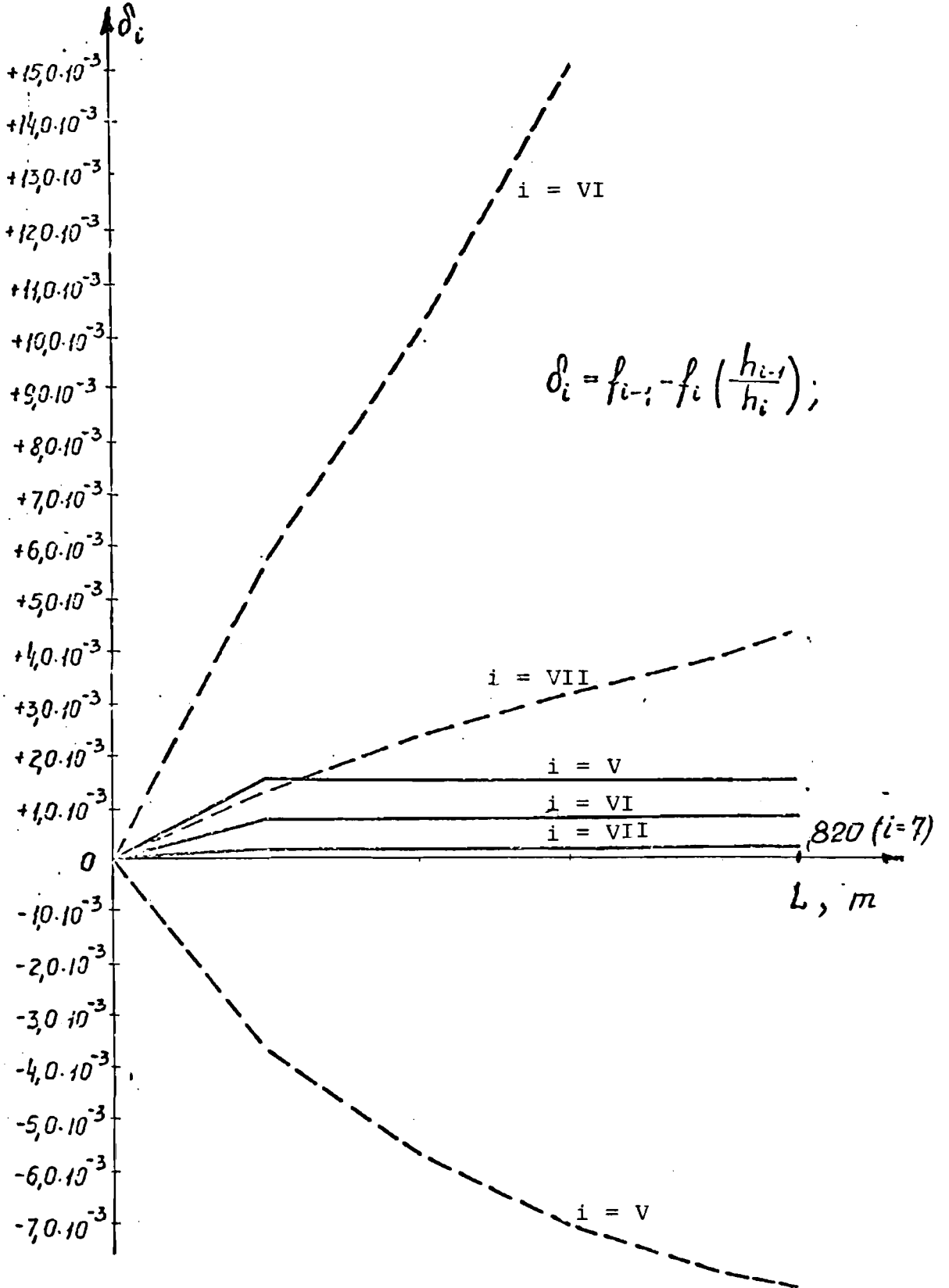

Figure 6.11. Change of non-flatness along the strip length in the finishing stands V-VII (strip size 1.2 x 1250 mm). The identification is the same as in Figure 6.4.

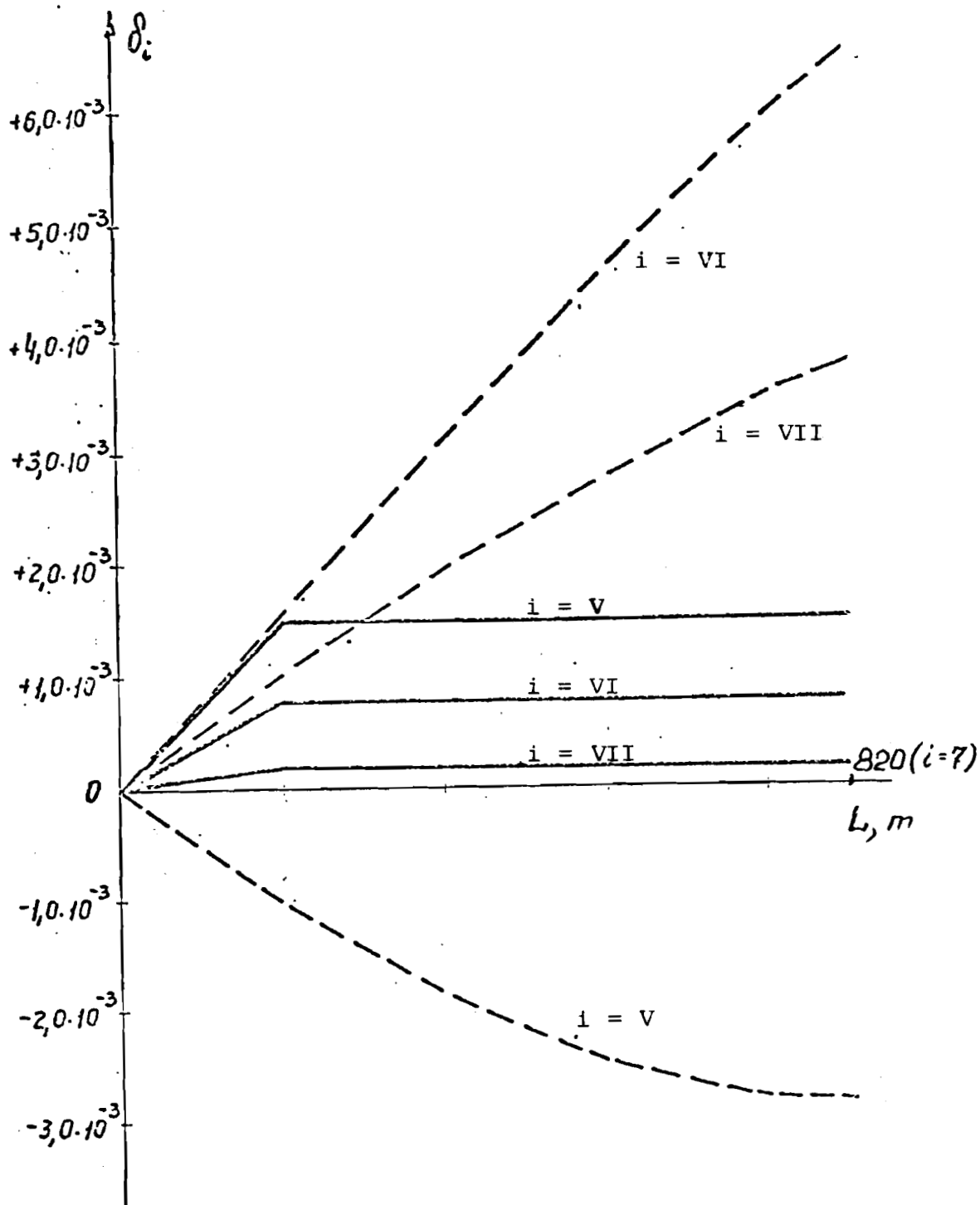

Figure 6.12. Change of non-flatness along the strip length (strip size 1.6 x 1250 mm). The identification is the same as in Figure 6.4 and in Figure 6.11.

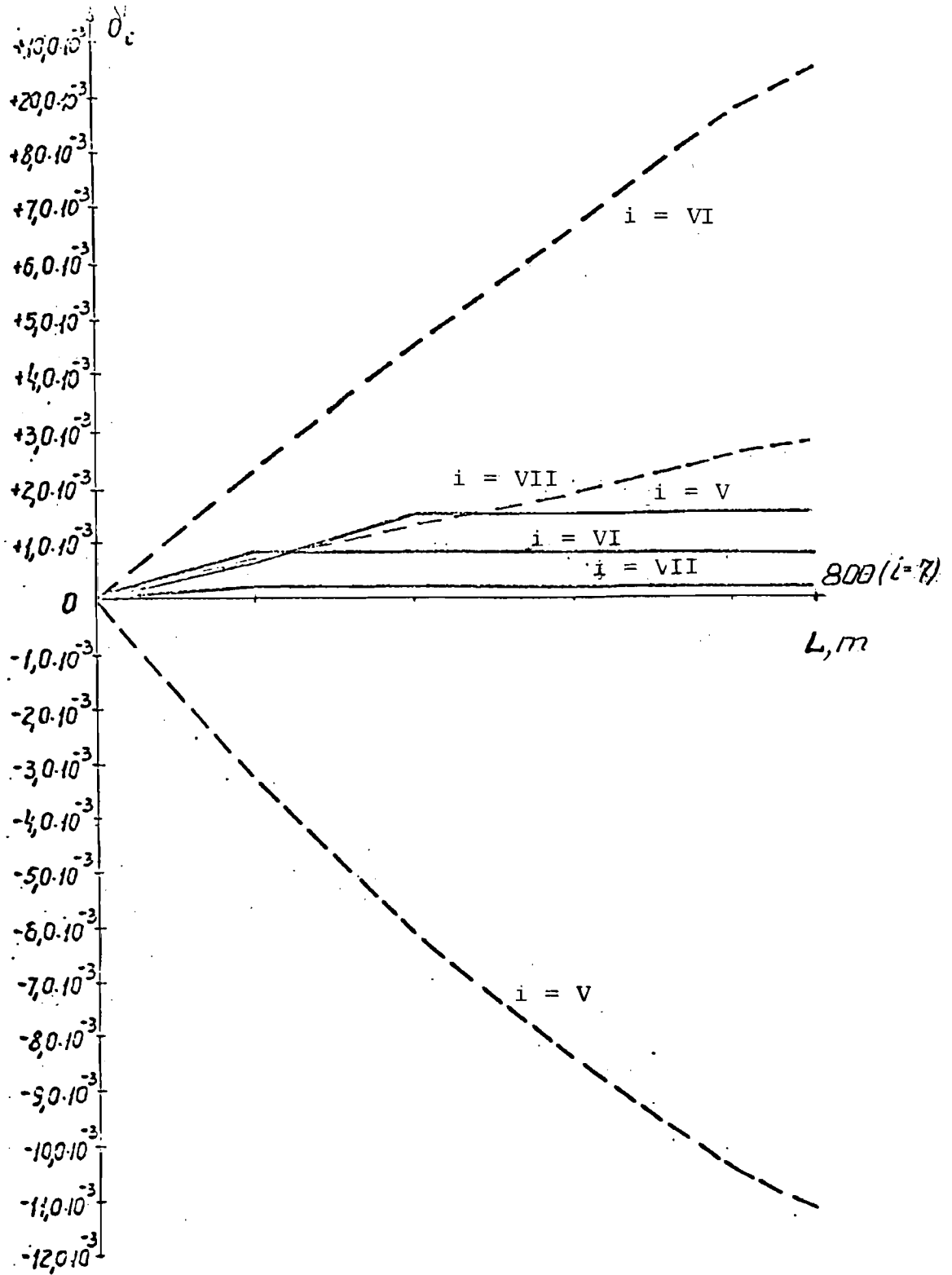

Figure 6.13. Change of non-flatness along the strip length (strip size 1.8 x 1250 mm). The identification is the same as in Figure 6.4 and in Figure 6.11.

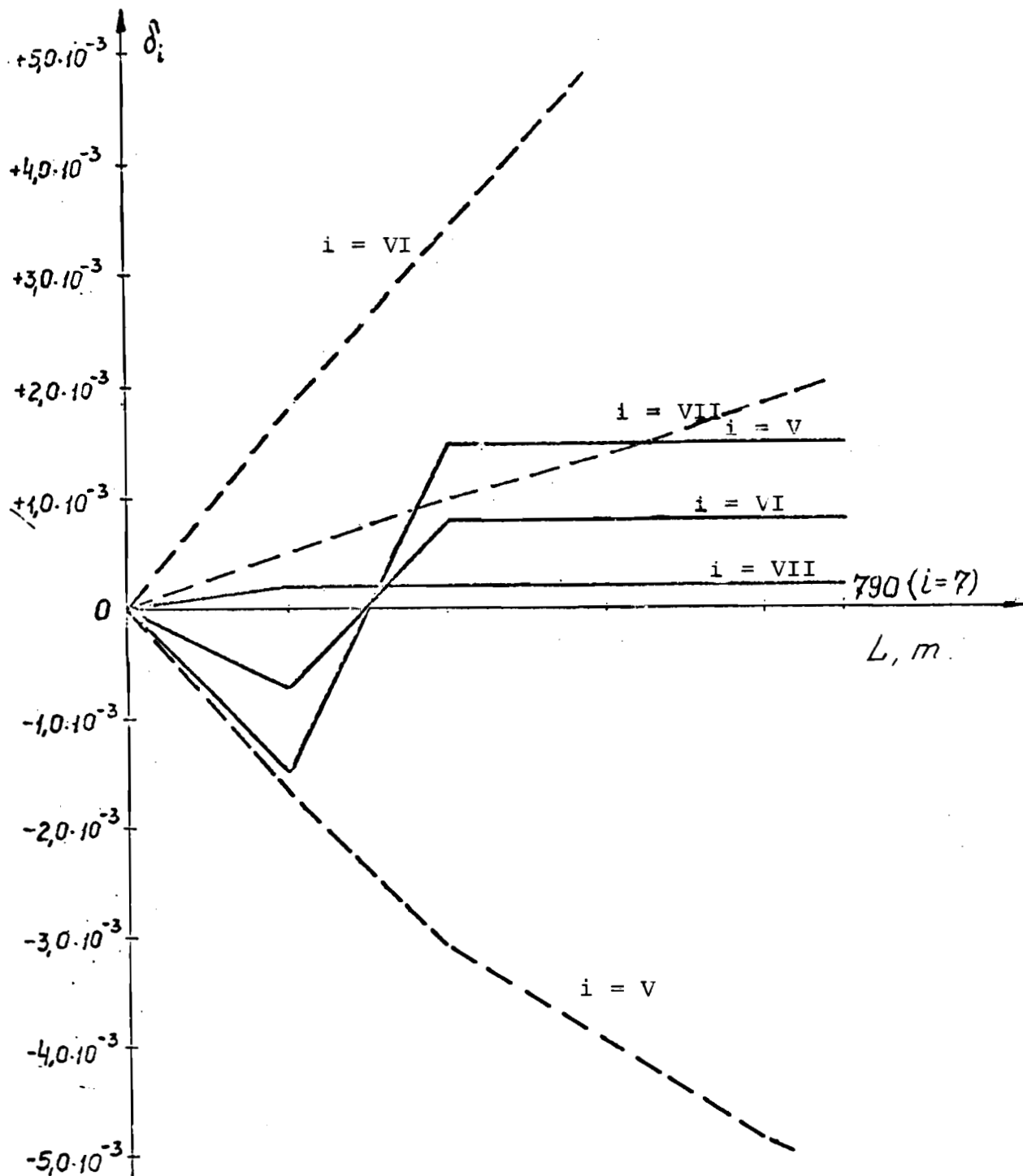

Figure 6.14. Change of non-flatness along the strip length (strip size 2.0 x 1250 mm). The identification is the same as in Figure 6.4 and in Figure 6.11.

References

- [1] Adrian, M., Cazimirovici, E., Genova, G. "Recherches experimentales sur l'influence des principaux parametres technologiques du laminage a chaud, en regime continu, des bandes larges en acier pour l'emboutissage profond." Rev. roum. sci. techn. Ser. met., 1972, v.17, No.2, 111-120.
- [2] Anke, Fritz. "Zunderbildung und Ertholung bei der Warm-Formung von Edlstahlen." "Bander-Bleche-Rohre," 1968, v.2, No.10, 587-590.
- [3] Belosevich, V.K., Netesov, N.P. Cold Rolling Process Improvement. Moscow, "Metallurgia," 1971.
- [4] Boyarshinov, M.L. and others. "Investigation of the Causes of Forming the Longitudinal Gage Variations and Methods of Excluding Them While Rolling the Strips Continuously." Stal, 1966, No.2, 146-151.
- [5] Butkovsky, A.G. Optimal Control Theory for Distributed Parameters. Moscow, "Nauka," 1965.
- [6] Butkovsky, A.G., Mal'yi, S.A., Andreev, Yu.N. Optimal Control of Metal Heating. Moscow, "Metallurgia," 1972.
- [7] Chekmarjev, A.P., Kachailov, A.P., Safjan, A.M. Heat Balance for a Single Stand Rolling Mill. In "Listoprokatnoe proizvodstvo." Moscow, "Metallurgia," 1973, 18-21.
- [8] Chekmarjev, A.P. and others. "Longitudinal Gage Variation While Rolling the Strips on Continuous Hot Thin Strip Mills." Izvestija VUZ. Chernaja metallurgia, 1964, No.11, 112-119.
- [9] Cheliustkin, A.B. Automation of Rolling Mill Production Control. Moscow, "Metallurgia," 1971.
- [10] Cheliustkin, A.B. Computing Technique Application for Steelmaking Automation. Moscow, "Metallurgia," 1960.
- [11] Cheliustkin, A.B. "Perspectives of Continuous Hot Strip Mill Control System Development." Presented at the Vth SEV and SFRYu Conference on Automation of Production Processes and Control in Iron and Steel Industry. Berlin, SEV, 1974.
- [12] Cheliustkin, A.B. Systems Approach to Production Control. Moscow, "Nauka," 1971.
- [13] Cheliustkin, A.B., Genkin, A.E., Tomashevskaja, V.S., Tsyfrinovich B.A., Koinov, T.A. "The Problems of Increasing the Output of Continuous Wide Hot Strip Mill Taking into Account the Limits of Final Product Quality." The paper presented at the All-Union Scientific-Technical Conference "Automated Management and Control Systems in Rolling Production (Development and Application)." Moscow, TSNIITEIpriborostroenie, 1973, 32-33.

- [14] Cheliustkin, A.B., Grigorjan, G.G., Logovatovsky, A. "Optimal Control of Hot Strip Mills According to Economic Criterion." Proceedings of the IFAC/IFORS Symposium. Varna, Bulgaria, October 8-11, 1974, 427-432.
- [15] Cheliustkin, A.B., Grigorjan, G.G., Koinov, T.A. "The Problem of Hot Rolled Strip Quality Improvement." Izvestija VUZ. Chernaja metallurgija. 1974, No.5, 59-63.
- [16] Cheliustkin, A.B., Grigorjan, G.G., Koinov, T.A. "The Influence of Speed-Temperature Rolling Conditions on Strip Flatness." Izvestija VUZ. Chernaja metallurgija, No.7, 1974, 90-97.
- [17] Cheliustkin, A.B., Koinov, T.A. "Thin Strip Temperature Changes When Rolling with Acceleration." Izvestija VUZ. Chernaja metallurgija, No.11.
- [18] Cheliustkin, A.B., Massalsky, Ja.S., Rjabchenko, L.M. "Compensation of the Back-Up Rolls Eccentricity of the Rolling Mill." "Mashinovedeniye", 1971, No.5, 17-22.
- [19] Cheliustkin, A.B., Tsyfrinovich, B.A., Genkin, A.L., Tomashevskaja, V.S. "Artificial Interstand Cooling of the Hot Rolled Strips." Izvestija VUZ. Chernaja metallurgija, No.11, 1973, 128-132.
- [20] Cheliustkin, A.B., Tsyfrinovich, B.A., Romashkevich, P.F. and others. "Artificial Interstand Strip Colling Conditions Along Its Length at the Hot Strip Mill." Izvestija VUZ. Chernaja metallurgija, 1974, No.3, 91-93.
- [21] Chepchugov, Yu.P. Rolled Metal Production Cost and Ways of Its Reduction. Moscow, "Metallurgija," 1973.
- [22] Cheplanov, V.I. "Technological Progress and Ferrous Metals Price Formation." Stal, No.7, 1973, 655-660.
- [23] Chernjavsky, A.A., Savinov, L.M., Ivanchenko, V.G. "Investigation of Mechanical Properties of Steel as a Function of Hot Rolling Condition." Continuous Strip and Bar Rolling, Dnepropetrovsk, "Metallurgija," 1971, 18-22.
- [24] Chizhikov, Yu.M. Reduction and Metal Rolling of Continuous Casting. Moscow, "Metallurgija," 1974.
- [25] Coldren, Arthur P., Cryderman, Robert L. "Hot Rolled Low Alloys Steels." American Metal Climax Inc. USA patent, 148-12 class (s. 21 7/14, s. 22s 39/30, No. 3726723). Referativnyi journal "Metallurgija", 1974, No.2.
- [26] Courcoulas, I.H., Ham, J.M. "Incremental Control Equations for Tandem Mills," Application and Industry, 1957, No.28, 363-374.
- [27] Dedek, V. Strips for Deep Drawing. Moscow, "Metallurgija," 1970,
- [28] Druzhinin, N.N. Continuous Rolling Mills as an Object of Automation. Moscow, "Metallurgija," 1967.

- [29] Druzhinin, N.N. "Main Regularities of Interconnected Changes of Values in Continuous Cold Strip Mill and Its Electric Drives." Trudy VNIIMETMASH, Moscow, "Mashgiz," 1962, No.5, 5-38.
- [30] Druzhinin, N.N., Likhoradov, A.P., Druzhinin, A.N., Mirer, L.G. "Speed Control of Continuous Hot Wide Strip Mill." Stal, No.8, 1972, 729-732.
- [31] Druzhinin, N.N., Mirer, A.G. "Analysis of the Electro-Mechanical Transient Processes of Tandem Mill Acceleration." Trudy VNIIMETMASH, Moscow, "Mashgiz," 1962, No.5, 39-70.
- [32] Duke, R.L., Hulls, L.R. "An Automatic Gage Controller for a 56-inch Reversing Steel Mill." Applications and Industry, 1959, No.3, 10-16.
- [33] Ess, I.G. "Fairless Works. United States Steels' Newest." Iron and Steel Engineer, 1954, v.31, No.6, 62-92.
- [34] Fainberg, Yu.M. Continuous Hot Rolling Mills Automation. Moscow, "Metallurgia," 1963.
- [35] Fainberg, Yu.M. "Metal Slip and Tension When Rolling with Variable Reduction." Stal, 1948, No.9.
- [36] Fedosov, N.M., Zheleznov, Yu.D., Tsyfrinovich, B.A., Matjukha, L.G. "Investigation of Physical-Mechanical Qualities Changes Along the Length of the Hot Rolled Strip." Stal, No.1, 1972, 67-69.
- [37] Fruzhin, I.I. Automation of Electric Arc Welding. Moscow, "Metallurgia," 1961.
- [38] Gallai, L.S., Merlin, N.M. "Influence of Steel Strip Rolling Reduction on Rolls Flattening." Izvestija VUZ. Chernaja metallurgia, 1961, No.10, p.59.
- [39] Garber, E.A. and others. "Creation of Mathematical Model of Temper Mill Rolls Thermal Profile." Izvestija VUZ. Chernaja metallurgia, 1972, No.5, 51-55.
- [40] Geifman, R.S., Rozin, B.B., Spasov, A.A. Economic-Mathematical Research in Steel Industry. Moscow, "Metallurgia," 1973.
- [41] Gertsev, A.I., Kirilin, N.M., Zjuzin, V.I., Shuinin, G.A., Lomtev, L.D., Titov, V.A. "Comparison of the Effectiveness of Different Cooling Systems Before Strip Cooling." Trudy VNIIMETMASH, Moscow, "Mashgiz," 1972, No.33, 235-250.
- [42] Gertsev, A.I., Shuinin, G.A. "Main Problems of Strip Quick Cooling at the Run-Out Table Installation Design Mills." Trudy VNIIMETMASH, Moscow, "Mashgiz," 1974, No.36, 146-157.
- [43] Ghun, G.Ya, Polukhin, P.I., Polukhin, V.P., Prudkovsky, B.A. Plastic Metal Deformation. Moscow, "Metallurgia," 1968.
- [44] Golishev, Yu.L., Struchenevsky, B.B. "Slab's Reheating Furnaces." Stal, No.5, 1974, 439-442.

- [45] Gorelik, V.S. and others. "Influence of Counterbending Efforts On Durability of the Working Rollers Bearings." Listoprokatnoe proizvodstvo, Moscow, "Metallurgia," 1973, 69-72.
- [46] Grigorjan, G.G., Zheleznov, Yu.D., Miroshnikov, I.K. and others. Bulletin of the Institute VNIICHERMET, 1974, No.2, 49-51.
- [47] Grubov, V.I. Mathematical Modelling of the Continuous Technological Processes. Kiev, Kievskii Universitet, 1971.
- [48] Grudev, P.I. "Main Causes of Gage Variations During Continuous Hot Rolling," Stal, 1958, No.9, 813-817b.
- [49] Grüner, A. "Untersuchungen über maschinenbedingte Einflüsse auf die Gleichmassigkeit Kalt gewalzter Bänder," Stahl und Eisen, 1957, v.6, s.77.
- [50] Haraguchi, S. "On the Relation Between Rolling Characteristics and Rigidity of Cold Rolling Mill." Journal of Japan Society for Technology of Plasticity, 1964, v.5, No.42, 465-473.
- [51] Heigi, Ikegami. "Technological Progress of Nippon Kokan in Flat Rolling Production." Express-Information. Rolling and Rolling Equipment, No.35, 1973, 12-16.
- [52] Hein, A.Ya. The Process Band- and Thin Strip Rolling. Moscow, "Metallurgia," 1941.
- [53] Hessenberg, W.C., Jenkins, N.N. "Effect of Screw and Speed-Setting Changes on Gage and Tension in Tandem Mills." Proceedings Mech. Engr., 155, v.169, No.52, 1051-1058.
- [54] Hessenberg, W.C., Sims, R.B. "Principles of Continuous Gage Control in Sheet and Strip Rolling." Proceedings of Inst. Mech. Engr., 1952, v.166, No.1.
- [55] Hollander, F.A. "Model Calculates the Complete Temperature Distribution in Steel During Hot Rolling." Mathematical Models in metallurgical process development. ISI Publ., London, 1970, 46-74.
- [56] Hollander, F.A., Huisman, R.L. "Computer Controlled Reheating Furnaces Optimize Hot Strip Mill Performance." Iron and Steel Eng., 1972, v.49, No.9, 43-56.
- [57] Hot Strip Mill for "Ponang Iron and Steel Co." Referativnyi journal "Metallurgia", No.4, 1974, p.140.
- [58] Hygh, S., Maxwell, R., Phillips, R.A. "Systems Analysis and Design for Hot Strip Mill with Automatic Gage Control." Steel Engineer, 1960, No.4, 111-118.
- [59] "Instruments for Shape Control of Strip." Steel Times, 1972, v.200, No.11, 789-791.
- [60] Ivanchenko, V.G., Taran, Yu.N., Pritonanova, M.I., Mazur, V.A. "Change of Structure and Mechanical Properties of Flat Steel." Listoprokatnoe proizvodstvo, No.2, Moscow, "Metallurgia," 1973, 9-15.

- [61] Ivanov, F.D. "Automatic Gage Control on Semi-Continuous Hot Strip Mill." Upravlenie tekhnologicheskimi oborudovaniem. Kiev, "Naukova Dumka," 1972, 126-129.
- [62] Ivanov, Yu.N., Klimovitsky, M.D. "Quasi Optimal Control for Metal Heating." Izvestija VUZ. Chernaja metallurgia, 1974, No.5, 166-169; No.7, 158-163.
- [63] Izzo, H.F. "A Mathematical Approach to Hot Strip Mill Controlled Cooling." Iron and Steel Engineer, 1972, v.49, No.9, 57-61.
- [64] Jalovoi, N.I. and others. Thermal Processes When Processing Metals and Alloys by Pressure. Moscow, Vysshaja shkola, 1973.
- [65] The Japanese Patent of the 18c, class, group 7/14 P1903552-24 (DT-AS 1903554). "Method of Strip Rolling For Deep Drawing." Journal Chernye metally, No.3, 1973, p.34.
- [66] Kaeslou, G., Eger, D. Heat Conductivity in Solids. Moscow, "Nauka," 1964.
- [67] Karlik, M.I. "Gage Control in Continuous Hot Strip Mill." Trudy Leningr. politekhnich. instituta, 1968, No.299, 100-104.
- [68] Kartashevsky, A.G., Livitsky, V.N., Makashov, V.V. and others. "Reduction of Unevenness of the Slabs' Heating in Continuous Reheating Furnaces." Bulletin of the Institute Chernetinformatsija, No.2, 1973, 51-52.
- [69] Kazakova, T.V., Nikolaev, V.A., Polukhin, V.P. "Investigation of the Contact Stresses During Rolling." Poljarizatsionno-opticheskii metod issledovaniya napryazhenii. Proceedings of the 5th All-Union Conference, Leningrad, LGU, 1966, 362-372.
- [70] Kenzo, T., Ichiro, I., Kazuo, I. "Computer Control of the 90-th Inch Hot Strip Mill at Kimitsu Works." Proceedings of the International Conference of Science and Technology in Iron and Steel, Tokyo, 1970, No.2, 1971, 737-742.
- [71] Kleshko, O.B. Strip Thickness Automatic Control During Rolling. Moscow, "Metallurgia," 1966.
- [72] Klimenko, V.M. and others. "Optimization of High-Speed Rolling Condition at Finishing Stand of Continuous Hot Strip Mill." Stal, No.8, 1973, 735-736.
- [73] Klimenko, V.M. and others. "Speed Rolling Condition Optimization of the Finishing Group of the Hot Strip Mills." Stal, 1973, No.8, 735-736.
- [74] Koji, Wada, Kazuo, Inue, Noziguake, Aosome. "Development of the Hot Strip Mills in Japan." Referativnyi journal "Metallurgia", No.5, 1974, 5D, 160.
- [75] Konovalov, Yu.V., Ostapenko, A.L. Temperature Condition of the Wide Hot Strip Mills. Moscow, "Metallurgia," 1974,

- [76] Kotzarj, S.L., Zheleznov, Yu.D., Poljakov, B.A. and others. "Investigation of the Hot Strip Mill's Finishing Train." Listovoe prokatnoe proizvodstvo, No.2, Moscow, "Metallurgia," 1973, 50-51.
- [77] Krenlitsch, H., Taschner, W. "Calcul des Conditions de Refroidissement sur la Table a'Arrosage d'un Train Continu a Grandes Bandes en Fonction de l'Epaisseur de la Baude, de la vitesse Finale de Laminage et des Temperatures de Fin de Laminage et de Bobinage." Circulaire d'Informations Techniques, 1971, No.9, 2037-2064.
- [78] Lamberights, M., Creday, T. "Hot-Working of Structural Steel. Microstructure and Design Alloys." Proc. 3rd Int. Conf. Strength Metals and Alloys. Cambridge, 1973, v.1, 392-396.
- [79] Lianis, G., Ford, H. "Control Equations of Multistand Cold Rolling Mills." Proceedings of the Institution of Mechanical Engineers, 1957, v.171, No.26.
- [80] Little, I.H., Chapman, I.A., Morrison, W.B. "The Production of Strength Plate Steels by Controlled Rolling. Microstructure and Design Alloys." Proc. 3rd Int. Conf. Strength Metals and Alloys. Cambridge, 1973, v.1, 80-84.
- [81] Livanov, V.A. and others. "Creation and Investigation of the Devices to Control the Rolls Crown at Cold Strip Mill." "Tekhnologija ljegkikh splavov", VILS, Moscow, 1968, p.41.
- [82] Lovlja, A.D., Nazarenko, D.I. "The Problem of Welded Seam Rolling on Tandem Cold Mills." "Metallurgicheskaja i gornorudnaja promyshlennostj", 1965, No.3, 36-38.
- [83] Lysenko, N.G. and others. "On the Problem of the Influence of the Hot Strip Mill Acceleration on Gage Variation." "Upravlenie tekhnologicheskimi oborudovanijem", Kiev, "Naukova Dumka," 1972, 126-129.
- [84] Malyi, S.A. Economic Metal Heating. Moscow, "Metallurgia," 1967.
- [85] Marshall, E.A., Shutt, A. "Measurement of Mill Stiffness." Journal of Iron and Steel Institute, 1966, v.203, No.8.
- [86] McManus, G.I. "Induction Heating: Key to Slab Casting System." Iron Age. Metal Work International, 1968, v.7, No.2, 40-41.
- [87] Meerov, M.V. and others. "Automatic Gage Control System of Hot Rolled Strip by Means of Self-Adjusted Program at 1450 Mill." "Avtomatizirovannyi eletroprivod proizvodstvennykh mekhanizmov". Moscow, "Energia", 1966, v.11, 158-162.
- [88] Meerov, M.V. and others. "Gage Control System Operation on 2500 Mill." Stal, 1967, No.9, 818-822.
- [89] Meerovich, I.M. and others. The Increase of the Sheet Rolling Precision. Moscow, "Metallurgia," 1969.

- [90] Meltzer, V.V., Salganik, V.M. "Analytical Investigation of Hydro-mechanical Control of the Working Rolls Counterbending." "Teorija i tehnologija prokatki" (Magnitogorskii metallurgicheskii institut), No.54, Cheljabinsk, 1968, 76-87.
- [91] Merlin, I.M. Hot Punching Technology. Sverdlovsk, UPI, 1965.
- [92] Merlin, I.M. "On the Relation Between Gage Variation and the Stand Inflexibility." "Issledovanie protsessov obrabotki metallov davleniem," issue 2, Izhevsk-Udmurtija Publishing House, 1967, 77-89.
- [93] Mirer, A.G. "Influence of the Back-Up Rolls Eccentricity on the Thickness and Interstand Tension Variations of the Strip During Continuous Cold Rolling." Trudy VNIIMETMASH, Moscow, "Mashgiz," 1963, No.10.
- [94] Morgan, E.R., Dancy, T.E., Korchynsky, M. "Improved High Strength Low Alloy Steels Through Hot Strip Controlled Cooling." "Blast Furnace and Steel Plant," 1965, v.53, No.10, 921-929.
- [95] Nemkin, E.D. and others. "The Influence of the Hot Rolling and Annealing on the Structure and Qualities of the Sheets Used for Car Manufacturing." Stal, No.11, 1030-1034.
- [96] "News in the Industry - News of Plant Installations, Contracts Equipment, and Processes Worldwide." Iron and Steel International, 1973, v.46, No.3.
- [97] Nikolaeva, A.N., Koljubakina, G.S. "Electric Heating of the Metal Prior to Rolling." Bulletin of the Institute Chernetinformatsija, No.14, 1972, 8-24.
- [98] Oppermann, K., Zheleznov, Yu.D. "Banddickenregelung über die Bandbreite durch anderung des Walzpalts beim Kaltwalzen." Neue Hütte, Berlin, 1969, No.1, S.23-29.
- [99] Pavlov, I.M. "Concerning the Role of the External Parts of the Strip in Different Cases of Rolling." Izvestija AN SSSR. Metally. Moscow, 1969, No.6, 101-106.
- [100] Pavlov, I.M. Theory of Rolling. Moscow, "Metallurgia," 1950.
- [101] Perelman, I.I. "Automatic Control According to the Self-Adjustive Program." Avtomatika i Telemekhanika, 1958, No.9, 813-823.
- [102] Phillips, R.A. "Methods of Control of Strip Dimentions on Hot Strip Finishing Mills." Iron and Steel Engineer, 1958, No.5, 100-107.
- [103] Plichko, N.P., Zheleznov, Yu.D. "On the Problem of the Metal Deformation Calculation During Hot Strip Rolling." Izvestija VUZ. Chernaja metallurgia, No.5, 1973, 98-101.
- [104]. Polonsky, L.S. and others. USSR Author's Certificate, B21B 1/26 class, No.406581. "Method of Hot Strip Rolling." Published on 21.11.1973. Bulletin "Otkrytija, izobretenija," No.46.

- [105] Polukhin, V.P. "Calculation of Interroller's Pressure and Rolls Bending of the Quarto Mills." Izvestija VUZ. Chernaja metallurgija, 1963, No.11, p.101.
- [106] Polukhin, V.P. "The Joint Influence of the Working Roll's Diameter and the Strip Width Under Rolling on Distribution of Interrollers Pressure and Rolls Bending on the Quarto Mills." Stal, 1964, No.2, p.145.
- [107] Polukhin, P.I. and others. Contact Interaction of Metal and Tools During Rolling. Moscow, "Metallurgia," 1974.
- [108] Polukhin, P.I. and others. "Elastic Deformations of Stand Rolls in the 1680 Quarto Mills Under the Counterbending." Izvestija VUZ. Chernaja metallurgija, 1969, No.11, p.100.
- [109] Polukhin, P.I. and others. "Investigation of the Temperature of the MMK 2500 Hot Strip Mill Working Rolls." Stal, 1973, No.9, 819-824.
- [110] Polukhin, V.P. and others. "Optimization of the Mill Passes Reduction for Increasing Finishing Rolling Temperature." Izvestija VUZ. Chernaja metallurgija, No.5, 1974, 64-68.
- [111] Polukhin, P.I. and others. "Concerning the Effectiveness of the Metal Shielding on Intermediate Rolling Tables." Izvestija VUZ. Chernaja metallurgija, No.8, 1974, 47-49.
- [112] Polukhin, V.P., Vishnjakov, Ya.D., Potjemkin, V.K., Chuvilek, V.P. "The Influence of the Temperature Conditions of Hot Rolling on the Structure and Mechanical Qualities of 08KP Steel." Izvestija VUZ. Chernaja metallurgija, 1971, No.1, 82-95.
- [113] Polukhin, P.I., Zheleznov, Yu.D., Polukhin, V.P. Thin Strip Rolling and Rolls Service. Moscow, "Metallurgia," 1967.
- [114] Popov, A.N. "On the Problem of Speed Effect." Stal, 1966, No.4, 342-345.
- [115] Richard, N.L. "Cold Rolled Sheet Expansion at Kaiser Steel." Iron and Steel Engineer, 1973, v.50, No.11, 54-59.
- [116] Ringer, L.E., Koss, G.S. "Automation Hot Strip Thickness Control - Geneva Works." Iron and Steel Engineer, 1960, No.2, 110-120.
- [117] Romenetz, V.A., Kremenevsky, S.V. Technical-Economic Analysis of BOF Operation. Moscow, "Metallurgia," 1973.
- [118] Rusov, R., Botev, N. "Investigation of the Temperature Rolling Conditions on the Strip Properties." Journal Rudodobiv i Metallurgia, (Sofia), 1971, No.3, 41-46.
- [119] Rutes, V.S., Askoldov, V.I., Evteev, D.P. and others. Theory of Continuous Casting. Technological Background. Moscow, "Metallurgia," 1971.
- [120] Safjan, M.M. Wide Strip Rolling. Moscow, "Metallurgia," 1969.

- [121] Safjan, M.M., Khutorjansky, M.I. "Experimental Study of the Rolls Crown and Strip Width Influence on the Rolls Load Distribution." "Listoprokatnoe proizvodstvo," No.2, Moscow, "Metallurgia," 1973, 25-28.
- [122] Savransky, K.N., Tkalich, K.N. and others. "Rolls Flattening." "Automation of the Steelmaking Production," 1973, No.1, 36-42.
- [123] Seredynsky, F. "Voraussage der Abkühlung von Grobblech beim Walzen." Journal of Iron and Steel Institute, 1973, v.211, p.3.
- [124] Sibakin, D. and others. "The Factors Which Influence the Profile of the Strip During Hot and Cold Rolling." "Prokatka i termicheskaja obrabotka lista." Moscow, "Metallurgia," 1962, 7-50.
- [125] Sims, R.B. "The Causes of Gage Variations in Hot Strip Mills and Their Correction." Iron and Steel Engineer, 1960, v.37, No.5, 69-83.
- [126] Singer, A.R., O'Brien, I.I. "Control of Shape of Metal Strip on Experimental Rolling Mill." Journal of Iron and Steel Institute, 1962, v.200, p.12, p.1003.
- [127] Sivilotti, O.G., Davies, W.Elfyn. "ASEA-ALCAN AFC System for Cold Rolling Flat Strip." Iron and Steel Engineer, 1973, v.50, No.6, 83-90.
- [128] Somerville, R.A. "Hydraulic Shaping in Cold Rolling." Iron and Steel Engineer, 1965, No.8, 83-90.
- [129] Stahl, U., Heinz, V. "Calculation of Rolls Bearings With Counter-bending." Journal "Chernye metally," 1968, No.24, p.43.
- [130] Sujarov, D.I., Benjakovsky, M.A. Quality of Thin Steel Sheets. Moscow, "Metallurgia," 1964.
- [131] Tischbein, Jack A. "Contour Control by Roll Shaping." Blast Furnace and Steel Plant, 1964, v.52, No.4, 328-330.
- [132] Tkalich, E.N., Goncharov, N.V., Britov, N.A. "The Change of the Temperature Field of the Slab in the Process of Rolling." Stal, No.1, 1974, 52-53.
- [133] Tkalich, K.N., Konovalov, Yu.V. Precise Rolling on Thin Strips. Moscow, "Metallurgia," 1972.
- [134] Trapeznikov, V.A. "Automatic Control and Economics." "Avtomatika i Telemekhanika," 1966, No.1, 5-22.
- [135] Tretjakov, A.V. Theory, Calculation and Investigation of the Cold Rolling Mills. Moscow, "Metallurgia," 1966.
- [136] Tretjakov, A.V. and others. "Bending of the Back-Up Rolls of the 4-High Mill." Stal, 1972, No.7, 621-624.

- [137] Tretjakov, A.V. and others. "Firmness of the Rolls While Cold Rolling." "Metallurg," 1961, No.12.
- [138] Tretjakov, A.V. and others. "Calculation of the Temperature Stresses of the Working Rollers During Cold Rolling." "Vestnik mashinostroenija," 1962, No.7.
- [139] Tselikov, A.I. "Control of Gage Variation Across the Strip Width by Means of the Working Rolls Counterbending." Stal, 1968, No.4, 338-342.
- [140] Tselikov, A.I. "A New Stage in Hot Strip Mills Development." Stal, 1973, No.6, 521-527.
- [141] Tselikov, A.I. "Quality Improvement of the Hot Rolled Strips by Means of the Working Rolls Counterbending While Rolling." Stal, 1969, No.5, 421-424.
- [142] Tselikov, A.I. Rolling Mills. Moscow, "Metallurgia," 1946.
- [143] Tselikov, A.I. Steel Industry Modern Problems. Moscow, AN SSSR, 1958.
- [144] Tselikov, A.I. Theory of Load in Rolling Mills. Moscow, "Metallurgia," 1962.
- [145] Tselikov, A.I. and others. "Strip Shape Control by the Working Rollers' Counterbending." Stal, 1968, No.4, p.338.
- [146] Tselikov, A.I. and others. "Working Stand Rigidity Influence on Longitudinal Strip Gage Variation." Stal, 1967, No.4, 336-342.
- [147] Tselikov, A.I., Zjuzin, V.I. Modern Development of Hot Strip Mills. Moscow, "Metallurgia," 1972.
- [148] Tsyfrinovich, B.A., Romashkevich, L.F., Dobronravov, D.N., Genkin, A.L., Pratushevich, A.E., Cherjatjev, A.P., Kharjkin, I.F., Kolesnikov, I.D. "Artificial Strip Cooling in the Interstands of Hot Strip Mills." Bulletin of the Institute Chermetinformatsija, 1973, No.73, 40-42.
- [149] Tsyfrinovich, B.A., Romashkevich, L.F., Ljambakh, R.B., Pratushevich, A.E., Karle, V.S. "The Effectiveness of Hot Strip Mill Temperature Control." Stal, 1974, No.6, 523-526.
- [150] Vydrin, V.N. "Equations of Continuous Rolling." Izvestija VUZ. Chernaja metallurgia, 1961, No.3, 61-66.
- [151] Vydrin, V.N. Dynamics of Rolling Mills. Moscow, "Metallurgia," 1960.
- [152] Vyrk, A.H. "Optimal Heating of the Massive Metals in Continuous Repeating Furnaces." "Avtomatika i Telemekhanika," No.7, 1970, 119-130, with ill.
- [153] Wall, Marion D. "Eccentricity Filter Rolling Mills," ISA Transactions, 1972, 11, No.11, 77-83.

- [154] Wilmotte, S., Mignon, I. "Model of Evolution of the Temperature of Strip in the Hot Strip Mill." Metallurgical reports CRM. Benelux, 1973, No.36, 35-44.
- [155] Wolf, H.U. "Influence of Variations in Critical Parameters in the Control of the Strip Thickness in Hot Strip Rolling Mills or Related to Selecting Regulating System Configurations." 111rd IFAC Congress, London, 1966.
- [156] Zheleznov, Yu.D. "Conditions Required for Getting Strip Flatness During Cold Rolling of Thin Sheets." Izvestija VUZ. Chernaja metallurgia, 1969, No.9, 64-68,
- [157] Zheleznov, Yu.D., Krutova, I.N., Tsyfrinovich, B.A. "On the Problem of Hot Strip Mill Speed Control." "Avtomatika i Tele-mekhanika", Moscow, 1970, No.7, 109-118.
- [158] Zheleznov, Yu.D., Kuznetsov, L.A., Grigorjan, G.G. "Investigation of the Regularities of Strip Flatness Formation While Rolling Thin Strips." Stal, No.10, 1972, 816-819.
- [159] Zheleznov, Yu.D. and others. "Modern Methods of Stabilization of Geometric Parameters of Hot Rolled Thin Strips." Bulletin of the Institute Chernetinformatsija, 1966, No.23, 15-17.
- [160] Zheleznov, Yu.D., Tsyfrinovich, B.A. "On the Problem of the Strip Heat Balance in Continuous Hot Strip Mill." Izvestija VUZ. Chernaja metallurgia, No.9, 1968, 105-110.

