



REVIEW

Food security through translational biology between wheat and rice

Ravi Valluru¹, Matthew P. Reynolds¹ & Tanguy Lafarge²¹Global Wheat Program, International Maize and Wheat Improvement Center (CIMMYT), El Batan, Mexico²Cirad, UMR AGAP, F-34398, Montpellier, France**Keywords**

Comparative biology, rice, translational biology, wheat, yield potential

Correspondence

Ravi Valluru, Global Wheat Program, CIMMYT, El Batan, CP 56237, Mexico.

Tel: +52 55 5804 2004;

Fax: +52 55 5804 7558;

E-mail: r.valluru@cgiar.org

Received: 5 May 2015; Revised: 31 July 2015;

Accepted: 27 August 2015

doi: 10.1002/fes3.71

Abstract

Wheat and rice are the most important food crops in agriculture providing around 50% of all calories consumed in the human diet. While both are C₃ species, the evolution and domestication of wheat and rice occurred in very different environments, resulting in diverse anatomical and metabolic adaptation. This review focuses on the current understanding of their adaptation in an agronomic context. The similarities and differences between wheat and rice are discussed, focusing on traits related to phenology, photosynthesis, assimilate partitioning, and lodging resistance, these being the main abiotic drivers of yield expression in most agro-ecosystems. Currently, there are significant knowledge gaps in the major biological processes that account not only for differential adaptation among cultivars within each species, but even between the two species. By addressing what is known as well as where gaps exist in a comparative context, this review aims to highlight translational research approaches that could provide insights into the genetic improvement of both crops.

Introduction

Wheat and rice are important cereal crops providing more than 50% of daily caloric intake worldwide. Taxonomically, wheat and rice represent different subfamilies of the Poaceae: Pooideae and Bambusoideae, respectively, and represent important models for comparative studies of the grasses because various aspects of their biology have been well studied (Sorrells et al. 2003; Shingaki-Wells et al. 2011; Cantu et al. 2013). Both wheat and rice have been domesticated in different climates, wheat is almost exclusively a dry-land winter crop, whereas rice is typically grown under tropical climates where most of the production comes from anaerobic/flooded soils (Nagai and Makino 2009; Shingaki-Wells et al. 2011). Such distinct evolutionary backgrounds triggered differential anatomical and developmental aspects resulting in various optimal growth conditions, yet they operate similar central metabolic processes (C₃ metabolism).

In the recent decades, the comparative biology between wheat and rice has been the subject of many studies (Sorrells et al. 2003; Shingaki-Wells et al. 2011; Cantu et al. 2013; for review, see Valluru et al. 2014). The study of two species may be useful in highlighting mechanisms of yield potential and stress adaptation in view of their domestication. Such distinct knowledge bases can lead to new knowledge, hypotheses, and predictions about related species and contribute to our knowledge of crop species evolution and adaptation to environment. Crop improvement programs can use comparative biology to transfer information on “traits” between relatively close species as well as more distant taxonomic groups. The genetic and molecular bases of yield-related traits were recently presented as a useful comparative biology approach between wheat and rice for application in translational research (Valluru et al. 2014). This review compares agronomic and physiological traits in two crop species.

Grain Yields of Wheat and Rice: Genetic Gains and Impacts

Genetic gains for wheat yields in the post Green Revolution period are widely reported to be in between 0.5% and 0.8% per year and globally the average annual absolute genetic gain of spring wheat reached about 40 kg ha⁻¹ year⁻¹ (Morgounov *et al.* 2010) despite the similar relative gains in irrigated and rainfed environments (Rajaram and Braun, 2008). Genetic gains in spring wheat continue to date (1995–2010) in both irrigated (Sharma *et al.* 2012) and rainfed environments (Manès *et al.* 2012) at an average of 0.6% and 1.0% p.a., respectively. Genetic gains in winter wheat appear to be stagnating in many parts of the world including the great plains of North America and the Europe (Brisson *et al.* 2010; Graybosch and Peterson 2010).

In rice, absolute yield gain in the range of 16–80 kg ha⁻¹ year⁻¹ were reported, being greater for Philippines (75–80 kg ha⁻¹ year⁻¹) and smaller for Brazil (16–45 kg ha⁻¹ year⁻¹) during the period 1966–1981 (Peng *et al.* 2000; Breseghello *et al.* 2011). The hybrid super rice shows 10–20% yield gain in China (Peng *et al.* 2008), while at IRRI tropical hybrids have showed 11–14% yield gain in Philippines (Fischer and Edmeades 2010). A recent comparison between hybrids and inbreds found 14–18% yield advantage for the hybrids (Bueno and Lafarge 2009). Overall, improvements in yield gain have been achieved through an ideotype approach (e.g., shorter plants, more fertile tillers, high early vigor, and CGR [crop growth rate], larger panicles) and the development of hybrid rice (which itself benefited from the ideotype approach).

Agronomic and Physiological Trait Associated With Yield Potential

With recent emphasis on food security, two major avenues have been highlighted to improve the genetic potential of yield in wheat: (1) increasing photosynthetic capacity and efficiency to raise the biological threshold in terms of total plant mass available for yield formation; and (2) optimizing partitioning to grain while maintaining lodging resistance such that increased genetic potential is realized as agronomic gains (Reynolds *et al.* 2009; Foulkes *et al.* 2011; Parry *et al.* 2011). Prebreeding to combine favorable expression of yield potential traits – focused on achieving a more optimal balance between assimilation capacity (source) and grain sites (sink) – has been successful in increasing yield levels in international trials (Reynolds *et al.* 2015).

In rice, trait-based selection was used to add specific traits into new plant types (e.g., NPTs) whereby NPTs served as a basis for the generation of high-yielding

cultivars/hybrids with larger panicles and higher tillering fertility (Peng *et al.* 2008). However, yield-based selection has shown to be more effective in increasing grain yields in rice than trait-based selection; although some researchers question the relevance of the traits used (Yuan *et al.* 2011) like the higher tillering fertility that may be inversely correlated to the tillering capacity (Lafarge and Bueno 2009). Here, we briefly summarize important agronomic and physiological traits contributing to yield potential.

Crop phenology

For cereals, reproductive growth is clearly the most critical physiological function to understand and modify thereby permitting accumulation of biomass to be translated into maximal expression of yield. While wheat exhibits a great plasticity for phenology (Sadras *et al.* 2009), it is yet to achieve its theoretical maximum harvest index of 0.6, and typically expresses values between 0.4 and 0.5, suggesting major opportunities for yield improvement without even changing RUE (radiation use efficiency) or biomass (Foulkes *et al.* 2011). Breeding efforts during the 20th century have reduced sowing to anthesis duration in durum wheat in Spain (8 days) and Italy (2 days) (Álvarez *et al.* 2008; Isidro *et al.* 2011), although this trend has reversed in some recent CIMMYT cultivars (Fischer 2001; Underdahl *et al.* 2008). The duration between sowing to terminal spikelet decreased while the duration between booting to anthesis increased, which diminished floret abortion (24%), increased grain number (23%) and grain set (13%) from old to modern cultivars (Isidro *et al.* 2011). Furthermore, the stem elongation period has been shown to exhibit the greatest sensitivity to environment, independent of the major phenological genes (García 2011). It is known that earliness *per se* affects the duration of preanthesis phases and spike development in cereals (Faricelli *et al.* 2009; Borràs-Gelonch *et al.* 2011, 2012). These studies suggest that earliness *per se* could be important to understand phenological phase plasticity to the environment, and it remains to be determined to what degree environmental effects confound or interact with genetic expression of phenological phases.

In rice, the genetic variation in postflowering period (from flowering to maturity) is relatively small for a given environment (Peng *et al.* 2000), while the preflowering phase (from sowing to flowering) varies greatly (Vergara and Chang 1985; Yin *et al.* 1997a). The cultivars released at IRRI since 1980s show slightly decreased crop duration (6 days) than the cultivars released before 1980s (Peng *et al.* 2000) due to shortened vegetative period, while the reproductive and grain-filling periods were largely unaffected. One of the objectives of the reduced crop cycle in the tropics is to grow three crops a year. In Texas,

rice cultivars (1944–1992) showed a 12–18 days decrease in heading time (Tabien et al. 2008). The Brazilian cultivars (1984–2009) showed an average genetic loss of -0.25 day years⁻¹ in days to heading (Bresseghele et al. 2011). Taken all together, both wheat and rice breeding programs have affected phenological pattern with crop duration and the length of the preanthesis period slightly decreased in both crops.

Photosynthesis and related traits

Light interception

LAI (leaf area index) beyond 3 is generally considered not an option for increasing light interception in wheat (Parry et al. 2011) because no apparent improvement in percent of light interception was observed in historical cultivars (Acreche et al. 2009). In contrast, LAI reaches 9 in rice depending on the developmental stage (Lü et al. 2007; Zheng et al. 2008; Zhang et al. 2009). Recent 3D models suggest that mean leaf inclination angles of rice cultivars range between 65° and 75° (70–90 in the upper canopy, while it is 30–60 in the lower canopy) (Zheng et al. 2008).

Modern rice and wheat cultivars have more erect and longer leaves in the upper canopy (flag-leaf). On average, rice plants receive 700–800 $\mu\text{mol photons m}^{-2} \text{ sec}^{-1}$ at the canopy top, with a total light interception of 80% of incident (Zheng et al. 2008). It has been estimated that leaves, panicles, and stems contribute about 80%, 15%, and 0.5% to the total light interception in rice (Saitoh et al. 2002). Reducing the panicle height to below top leaves or removing panicles (this allowed top leaves to access more light) have shown to increase leaf gas exchange rate about 15–50% (Setter et al. 1995; Saitoh et al. 2002). While more erect leaves/smaller leaves may allow light distribution to the lower canopy (Horton 2000), the genetic manipulation of leaf position, size, and thickness/density still needs to be explored since its manipulation is not straightforward.

Leaf photosynthesis

The relationship between the A_{max} (light-saturated only) and grain yield is not straightforward (Long et al. 2006) although the differences in A_{max} and its genetic variation can moderately contribute to variations in yields (Nelson 1988). Since modern hexaploid wheat species have lower A_{max} (postulated to be due to an inhibitory effect of D genome on gene expression in the A and/or B genomes and larger mesophyll cell sizes) than diploid and tetraploid species (Koç et al. 2003), these genetic pools may serve as sources for increasing A_{max} . For example, emmer wheat

(*Triticum dicoccoides*) shows a large genetic diversity for A_{max} , which is independent of leaf anatomy (Carver and Nevo 1990). Genetic advances in wheat yield does not appear to be related to changes in photosynthesis rate on an area basis when measured in the flag-leaf or the spike, but only to a higher, whole spike photosynthesis rate (Zhou et al. 2014), suggesting that under potential yield conditions, the spike with respect to its size, may contribute more than the flag-leaf to yield formation. The awns of wheat are an important photosynthetic and transpiration organ on the spike. It has been reported that the pathway for assimilation movement from awns to the kernels is minimal (Evans et al. 1972). Furthermore, the activity of PEP carboxylase is much higher in awns than in flag leaves throughout ontogeny, and is particularly high at the late stages of grain filling (Li et al. 2002, 2006).

In rice, increasing A_{max} has been proposed to be a more effective strategy for increasing RUE than improving canopy architecture as modern rice varieties are believed to have an optimal canopy architecture in terms of light and N distribution (Peng and Ismail 2004). A large genotypic variation exists for A_{max} in rice and its relatives (Cook and Evans 1983) particularly in diploid wild species (Yeo et al. 1994). Such large variation in A_{max} is associated with variation in stomatal conductance (g_s) at mid-day conditions, Rubisco content, specific leaf area, and total leaf protein (Hubbart et al. 2007). A_{max} at each developmental stage was better explained by g_s , especially under mid-day conditions while N content explains changes in A_{max} associated with crop development (Ohsumi et al. 2007). Interestingly, since genotypic variation in N is unrelated to g_s ; these two traits could be modified independently to increase A_{max} . Nevertheless, under light-saturated conditions, g_s generally decreases due to decreased leaf water potential, therefore increasing leaf hydraulic conductance under saturated light should be targeted in breeding (Taylaran et al. 2011).

The physiological regulation of two parameters, TPU (triose phosphate utilization) involved in inorganic phosphate (Pi) recycling, and g_m , the mesophyll conductance, has received far less attention. Limited sink strength results in the accumulation of photoassimilates in the leaf, as a signal for downregulation of photosynthesis, reducing TPU (Zhu et al. 2010; Nebauer et al. 2011). This points to the value of exploring genetic variability in TPU regulation. Also, the reduction in g_m , standing for the diffusive conductance of CO₂ from the stomata to the chloroplast, significantly limits photosynthesis (Flexas et al. 2008; Griffiths and Helliker 2013) with variation in leaf anatomy assumed to be a major factor (Tomas et al. 2013). However, despite substantial evidence for large genotypic variability of g_m , exactly how leaf anatomy interacts with g_m to

determine leaf $[CO_2]$ status remains unclear. Overall, these studies suggest that while both crops exhibit different limitations to increase net photosynthesis, manipulating specific trait dynamics may improve photosynthesis rate in both crops (Fig. 1).

Canopy photosynthesis and N distribution

Canopy photosynthesis is largely a function of the vertical distribution of light and nitrogen (light-harvesting proteins and Rubisco), as well as sink activity (Dreccer et al. 2000; Bertheloot et al. 2008). The relationship between plant height and photosynthetic capacity is always not consistent (Gent and Kiyomoto 1984; Gent 1995; Bishop and Bugbee 1998). Semi-dwarf wheat often shows higher canopy photosynthesis at anthesis, which may be linked to stronger sinks associated with more efficient assimilate partitioning at anthesis (Bishop and Bugbee 1998), suggesting that in tall genotypes, the rate of photosynthesis might be partly constrained by assimilate export from leaves. In addition, cultivars with greater capacity to store N in nonphotosynthetic tissues may improve canopy N distribution (Dreccer et al. 1998) particularly if it follows the light gradient (Dreccer et al. 2000; Bertheloot et al. 2008). Recently, the contribution of ear photosynthesis to grain filling was highlighted, especially in situations of source limitation (Maydup et al. 2012).

In rice, an improved canopy structure has increased canopy photosynthesis particularly during the grain-filling period (Zhang and Kokubun 2004). However, the relationships between canopy net photosynthetic rate and biomass, and yield were inconsistent (Peng 2000) probably due to a high genetic variation in canopy photosynthesis during postanthesis (Zhang and Kokubun 2004). With

LAI of 5, erect leaves allow higher canopy photosynthesis, while with LAI lower than 3, droopy leaves can allow higher canopy photosynthesis (Peng and Ismail 2004). Therefore, an ideal phenotype should have a prostrate-leaf canopy in the very early growth stage to intercept PAR effectively, while more erect leaves at the later stages would allow light to penetrate more efficiently. Moreover, rice leaves can efficiently maintain lower canopy temperature via efficient transpiration cooling given sufficient water availability (Wassmann et al. 2009; Gao et al. 2011). Depending on the N concentration, either linear ((Makino et al. 1988) or curvilinear (Cook and Evans 1983) relationship with photosynthesis was observed (Shimoda 2012). Modeling studies suggest that if leaf N content can be increased above 1.8 g N m^{-2} in upper leaves, daily canopy photosynthesis rate can be increased regardless of plant density and light condition (Shiratsuchi et al. 2006). Such steeper gradient of leaf N in the canopy increases daily canopy photosynthesis by 20–25%. Both leaf area and tillering capacity should be large at early stages (Lafarge and Bueno 2009), but restricted during grain filling to avoid strong mutual shading and to allow radiation to reach deeper leaf layers to realize gains in canopy photosynthesis with increasing leaf N content. In this regard, it is particularly interesting that new plant types have very erect leaf orientation and relatively small number of productive tillers that could be useful to increase canopy photosynthesis (Horton 2000).

Radiation use efficiency

Until last century, RUE during preanthesis has not been significantly improved in modern wheat cultivars (Gutierrez-Rodriguez 2000). In irrigated environments, no

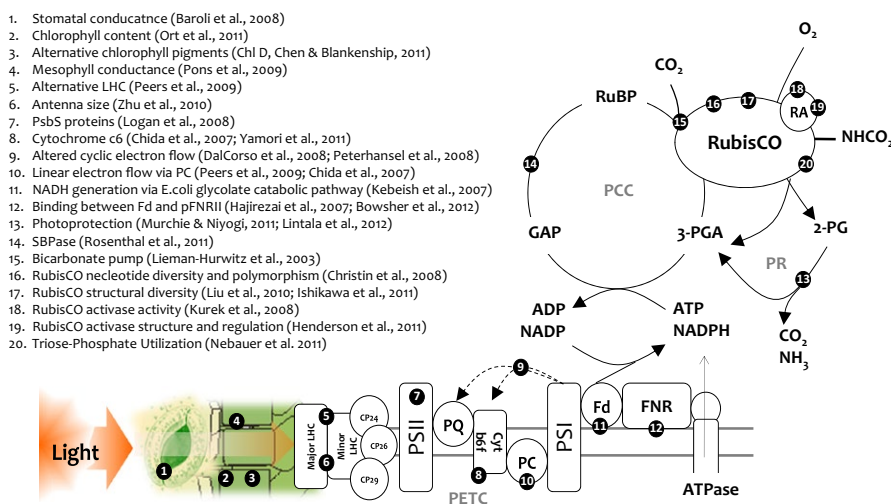

Figure 1. Proposed avenues for enhancing photosynthesis rate in wheat and rice.

differences in RUE or light interception between old and modern cultivars were found, while modern lines were shown to have higher RUE after anthesis (Calderini et al. 1997) largely driven by high sink. Cultivars with cooler canopy temperature exhibit an enhanced gas exchange rate (Ayeneh et al. 2002); hence, cooler canopy can increase crop yields especially under mild stress (Ayeneh et al. 2002). A 2.5°C range in canopy temperature depression at anthesis has been reported for Iranian wheat cultivars (Karimizadeh and Mohammadi 2011). Although diverse mechanisms may theoretically explain genetic variation in canopy temperature (Rebetzke et al. 2012), so far only root depth and capacity has been implicated through direct measurement (Lopes and Reynolds, 2010) and genetic studies in dry residual moisture and hot, irrigated environments (Pinto et al. 2010; Pinto et al. 2014). These studies suggest that RUE can still be improved in both crops and the underlying mechanisms of CTD differing between genotypes need to be explored.

In rice, RUE has reported to increase from old cultivars to modern cultivars. New indica varieties expressed more RUE (2.14 g MJ⁻¹) than traditional (1.8 g MJ⁻¹) and japonica varieties (1.8 g MJ⁻¹) (Boschetti et al. 2006) due to differences in morphophysiological characters (Kiniry et al. 2001). However, RUE in rice is considered to be lower (under aerobic conditions, ~1 g MJ⁻¹; in flooding, ~2.2 g MJ⁻¹) as compared to the average quantum requirement of C₃ species (2.9 g MJ⁻¹) (Katsura et al. 2010). This may underlie the poor association between RUE and yield superiority of super hybrid rice varieties (Katsura et al. 2008, 2010). Nevertheless, a higher RUE especially during postanthesis can increase thousand-grain weight (Sadras and Lawson 2011). In wheat, photosynthetic capacity can be improved by increasing green leaf area duration and chlorophyll content of tissue, while stomatal conductance and a cooler canopy temperature are indicative of improved RUE (Sadras and Lawson 2011; Xiao et al. 2012).

Leaf senescence

In wheat, leaves contribute about 40% to the daily rate of grain N accumulation at mid grain filling (Simpson et al. 1983). Hence, a delayed leaf senescence or stay green, which maintains active photosynthesis for longer period may increase grain yields (Gregersen et al. 2008; Bogard et al. 2011). In contrast, accelerated senescence leads to low C but high N remobilization indicating the plasticity of senescence linked to carbon and N remobilization. Such senescence regulation of C and N could be a viable strategy to alter both C and N remobilization to the actively developing grains. While several patterns of senescence were proposed (Thomas and Howarth 2000),

an ideal senescence phenotype in wheat, in general in cereals, still needs to be identified (Gregersen et al. 2008; Bogard et al. 2011). The advent of high-throughput spectral tools such as the GreenSeeker has made it more feasible to study total canopy N remobilization dynamics (Lopes and Reynolds 2012).

In rice, a functional stay-green phenotype exhibits higher light conversion efficiency and net photosynthetic rate at saturated light throughout grain filling (Fu and Lee 2012). It also maintains mesophyll conductance due to high chlorophyll content and delays the degradation of photosystem II. Interestingly, the stay-green trait is associated with high root activity so higher capacity to accumulate and maintain high N (Fu et al. 2009) and with higher grain-filling rate under limited radiation conditions (Buono and Lafarge, unpublished data). These studies suggest that the stay-green trait is beneficial to increase root activity and N accumulation during grain-filling period under favorable environments.

Nitrogen use efficiency and biological nitrification inhibition

Genetic gains in NUE under low N supply were associated with the improvements in NUpE (uptake efficiency) in spring wheat and to NUtE (utilization efficiency) in winter wheat (Brancourt-Hulmel 2003), while under high N, both components contribute approximately equally to NUE (Ortiz-Monasterio et al. 1997; Muurinen et al. 2006; Wang et al. 2011). These studies indicate that NUpE may be influenced by G × N interaction, while G × E interaction may influence NUtE. Although leaf senescence kinetics could explain the genetic variability associated with yield variation under low N (Gaju et al. 2011), the strong negative association between NUpE and NUtE highlights the necessity of understanding mechanisms influencing the uptake and utilization of N by crops. Modified root architecture associated with dwarfing genes is one parameter influencing NUE (Wojciechowski et al. 2009; Gooding et al. 2012). Alternatively, BNI (biological nitrification inhibition) may improve NUE. The wild wheat, *Leymus racemosus*, shows higher BNI release rates ranging from 20 to 30 allyl thiourea g⁻¹ root dry wt. day⁻¹ (Subbarao et al. 2007). A locus for high BNI was transferred to cultivated wheat using chromosome addition lines of wild wheat, however, these lines carry many undesirable traits compromising yield potential.

In rice, a large genotypic variation in NUE has been reported, ranging from 38 to 84 kg kg⁻¹ for grain and 100 to 160 kg kg⁻¹ for biomass, probably under aerobic and rainfed management (Koutroubas and Ntanos 2003). However, improving NUE for grain in favorable (irrigated) environments has been limited in breeding (Samonte

et al. 2006). Indica cultivars generally have higher NUE for grain than japonica cultivars (Koutroubas and Ntanos 2003). Such large variations could be related to yield potential because high-yielding cultivars show less genetic variation in NUE for grain (Samonte *et al.* 2006). Moreover, NUE for grain is also influenced by plant height, crop growing duration (short and late maturing cultivars have high NUE for grain than tall and early maturing varieties; Koutroubas and Ntanos 2003), percentage of straw N, grain N concentration, and HI. At HI of 0.5, both straw and grain N equally contribute to NUE for grain; therefore, increasing HI would be associated with NUE for grain. However, genotypic variation in grain N concentration is low (0.95–1.2; Tirol-Padre *et al.* 1996), therefore, it may not be feasible to improve NUE for grain by reducing grain N concentration using conventional breeding as grain N concentration is affected more by environments than by genotypes (Ladha *et al.* 1998). Genetic variability for nitrogen metabolism in the developing ear of maize has been suggested to improve yields (Cañas *et al.* 2012). BNI improves N uptake and NUE due to its inhibitory effects on nitrification (Subbarao *et al.* 2006). A significant genotypic variation in BNI (<10% to >50%) was reported (Pariasca Tanaka *et al.* 2010). However, traditional and upland varieties exhibit high BNI activity than the modern irrigated lowland varieties. While nitrification rates in paddy soils are lower compared to typical upland soils, application of synthetic nitrification inhibitors has been shown to increase yields (Li *et al.* 2009) suggesting that BNI has the potential to improve yields in rice.

Source:sink regulation and lodging resistance

An approach to increase spike dry matter is to increase assimilate partitioning to spike at anthesis (Demotes-Mainard and Jeuffroy 2004). To some extent, dwarf and semi-dwarf cultivars have achieved this by increasing assimilates partitioning to developing spikes (Álvaro *et al.* 2008; Foulkes *et al.* 2011). For example, the dry matter partitioning to spikes at anthesis improved from 9% in old cultivars to 27% in modern semi-dwarf durum wheat in Italy and Spain (Álvaro *et al.* 2008). The genetic range for partitioning to the respective plant organs at anthesis (spikes, 0.12–0.29; leaf lamina, 0.19–0.31; stems and leaf sheath, 0.48–0.63; as a proportion of above-ground biomass; Reynolds *et al.* 2009) suggests that there is a possibility to increase assimilate partitioning to spikes (Foulkes *et al.* 2011). However, decreasing plant height further by developing double dwarfs may not provide any additional benefits because of reduced light interception and total biomass (Butler *et al.* 2005). Moreover, reduced cell

elongation and smaller cells have reduced seedling vigor in resource-poor environments (Botwright *et al.* 2005).

AGB (above-ground biomass) was not systematically increased from old to modern cultivars until relatively recently (China [Zheng *et al.* 2011]; U.K. [Shearman *et al.* 2005]; Australia [Sadras and Lawson 2011]; and Mexico [Aisawi *et al.* 2015]). Increased AGB shows two common trends with yield components: thousand kernel weight or grain weight in cultivars of Australia (Sadras and Lawson 2011) and Henan Province of China (Zheng *et al.* 2011), and grains per unit area or spikes per unit area in cultivars of U.K. (Shearman *et al.* 2005) and Shandong of China (Xiao *et al.* 2012). This suggests that biomass partitioning to yield components has been greatly modified resulting in distinct wheat ideotypes (Álvaro *et al.* 2008). An increased AGB especially during postanthesis shows strong correlation with yield (Reynolds *et al.* 2009). Nevertheless, the association between yield and biomass depends heavily on environment. Under stress, there is usually a strong association (Reynolds *et al.* 2007) but less so often when conditions are favorable. In addition, higher WSC (water-soluble carbohydrates) at anthesis are associated with higher grain weight and lower WSC storage is associated with increased grain number (Rebetzke *et al.* 2008; Sadras and Lawson 2011). While this trend is consistent with most modern cultivars, often an opposite trend with higher WSC storage and grain number was reported (Shearman *et al.* 2005; Xiao *et al.* 2012). These studies did not report any changes in grain weight, hence the associations between WSCs and yield components are unclear.

In rice, there has been a marked increase in HI and grain production by modification of the reproductive structures in the modern cultivars (Evans *et al.* 1984; Mohapatra *et al.* 2011) and hybrids (Yang *et al.* 2007), suggesting an increased partitioning of assimilates to reproductive organs (Lafarge and Bueno 2009). Modern cultivars show increased biomass production over old cultivars. Yield improvement in cultivars released before 1980 was associated with increases in HI, while the yield improvement in the cultivars released after 1980 was associated with increases in biomass (Peng *et al.* 2000) although it largely depends on comparisons between either semi-dwarf and traditional or among semi-dwarfs (Evans *et al.* 1984; Yamauchi 1994; Peng *et al.* 1998). Also, higher yields of hybrids were attributed to both high HI (Bueno and Lafarge 2009) and biomass (Bueno and Lafarge 2009; Zhang *et al.* 2009) mainly through higher growth rate of priority sinks and higher sink regulation, that is the timing and magnitude of the successive sink activities over crop growth (Bueno *et al.* 2010), to the favor of stem biomass at the end of the vegetative phase, panicle biomass at the end of the reproductive phase, and remobilization

from stem to panicle at the beginning of the filling phase (Lafarge and Bueno 2009; Bueno et al. 2010). Yet, it was reported that higher yield was attributed to higher biomass accumulation under favorable conditions and to higher HI under suboptimal conditions in the tropics (Peng et al. 2003). A recent study conducted on 32 high-yielding contrasted genotypes (hybrids and inbreds) from diverse geographical origin, and respective of their maturity groups, highlighted, however, that relevant traits were those favoring light capture in the favorable (dry) season and short plant height and delayed leaf senescence in the suboptimal (wet) season (Bueno and Lafarge submitted).

It has been estimated that during heading to maturity, an inbred rice allocates dry matter about 39.5% to panicles, 4.3% to leaves, 33.5% to stems, 6.5% to late tillers, and 6.7% to roots (Kato et al. 2006), suggesting that panicles have high demand for dry matter partitioning (Zhao et al. 2008). Indeed, in favorable conditions, hybrid rice shows a higher partitioning coefficient to culms in the late vegetative and early reproductive while lower partitioning coefficient to culms and higher partitioning coefficient to panicles in the later reproductive phases as compared to inbreds (Lafarge and Bueno 2009). This suggests a strong sink regulation and remobilization capacity with hybrids over the crop cycle (Bueno et al. 2010) through larger biomass partitioning to culm at late reproductive phase and HI. Indeed, in high-yielding recently bred varieties, equipped with large panicles (Fujita et al. 2013), grain filling of late flowering basal spikelets is particularly poor (Panda et al. 2009). Both NSC accumulation in the stems

at heading (Fu et al. 2011) and reduction in ethylene concentration in the basal spikelets (Wang et al. 2012) enhances sink strength of the basal spikelets at early grain filling by increasing number of endosperm cells and activities of sucrose synthase and AGPase (adenosine diphosphoglucose pyrophosphorylase). These studies suggest that increasing NSC accumulation in the stems and reducing ethylene production in the basal spikelets will induce fast-synchronized filling within the panicle and higher yield potential. In addition, there is growing evidence that the T6P (trehalose-6-phosphate) plays a central role in regulating carbohydrate and starch metabolism in plants as it indirectly reflects sucrose concentration and has been widely accepted as an indicator of sucrose status (O'Hara et al. 2013; Yadav et al. 2014). By regulating sucrose export to the grain, T6P could then increase sink strength in case of its higher concentration within the grain and has been shown to increase grain yields (Nuccio et al. 2015).

Lodging resistance

Strategies to raise HI should consider assimilate partitioning to structural organs to avoid any stem and root lodging. Models describing lodging resistance in wheat have highlighted stem thickness, stem wall material strength, and area of root plate in the stem and root lodging resistance (Berry et al. 2003b, 2007) (Fig. 2). Interestingly, lodged plants exhibited stronger source limitation during grain filling than unlodged ones (Acreche and Slafer 2011), highlighting the importance of photosynthetic activity

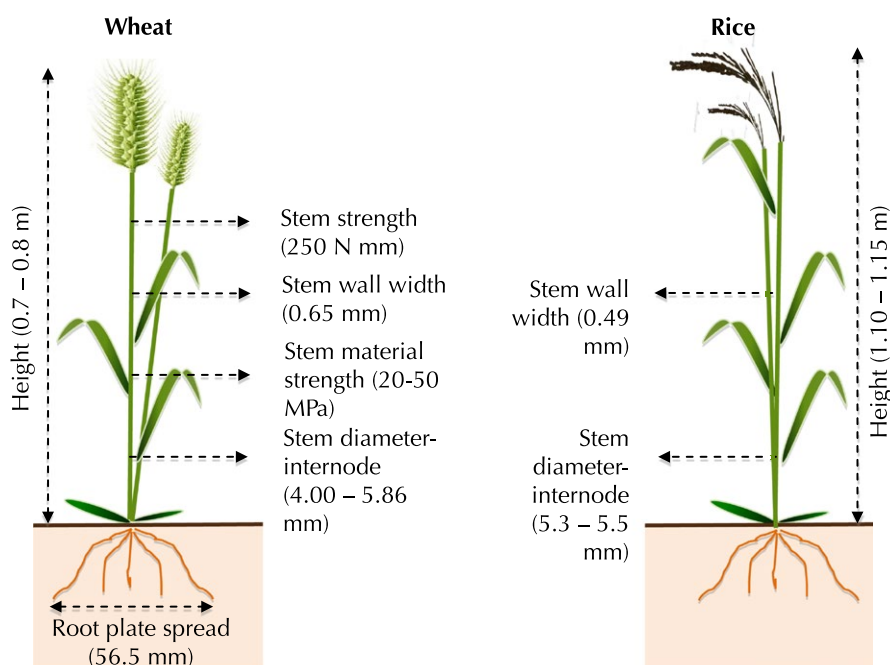

Figure 2. An ideotype design for lodging-resistant wheat and rice.

during grain filling to avoid any stem or root lodging. Reducing unproductive tiller number could also reduce lodging problems and increase grains per spike (9%) but decrease grain yields (8%) (Duggan *et al.* 2005; Gaju *et al.* 2011), as observed in China (Zheng *et al.* 2011) and Spain (Royo *et al.* 2006; Álvaro *et al.* 2008). The net redistribution of N and C to surviving shoots after their death is inconsistent being negative (Berry *et al.* 2003a) or positive (Thorne and Wood 1987). Although the efficiency of such transport is unknown, a high, early tiller production may enhance grain yields in cereals (Pasuquin *et al.* 2008).

Rice exhibits a large genetic variability in lodging resistance. Several lodging-related traits were identified (Islam *et al.* 2007). Lodging resistance was strongly correlated with the culm diameter and wall thickness of the basal internodes (Chuanren *et al.* 2004). A stem diameter of 5.3–5.5 mm (plant height of 114 cm under typhoon conditions) (Chuanren *et al.* 2004; Ishimaru *et al.* 2005) and stem wall thickness of 0.49 (Chuanren *et al.* 2004) were associated with lodging resistance. While plant height was not necessarily an important factor (Ishimaru *et al.* 2007), leaf sheath and the extent of wrapping (breaking strength of the shoot was increased by 30–60%) will be an important trait for selection against lodging at all developmental stages as shown in rice (Setter *et al.* 1994). In addition, mechanical properties such as tensile breaking point and the tensile elastic modulus are associated with lodging resistance (Chuanren *et al.* 2004). Clearly, while plant height is not necessarily being reduced, increasing stem wall thickness and mechanical properties can contribute to enhance lodging resistance.

Trait Differences and Similarities Between Wheat and Rice

Over the last two decades, the linear rate of yield change for wheat has been 25 kg ha⁻¹ year⁻¹, while it is 38 kg ha⁻¹ year⁻¹ for rice. However, the relative rates of yield increase seem to be the same (0.9%) for both crops (Fischer and Edmeades 2010). While reduction in plant height, increased biomass, and HI commonly resulted in yield gain in both crops, increased kernel number per unit area in wheat and increased CGR in rice are largely associated with yield gains (Fischer and Edmeades 2010; Pozo *et al.* 2014). The CGR between stem elongation and anthesis is increased in wheat particularly in the cultivars of Australia (Sadras and Lawson 2011), while CGR and early vigor (higher LAI) have been significantly increased in rice particularly in hybrids, which increased biomass accumulation and grain yield (Peng *et al.* 1998; Bueno and Lafarge 2009). In addition, net photosynthesis and RUE have been slightly increased in modern wheat while hybrid rice has a lower net photosynthetic rate during

vegetative and grain-filling phases because of lower leaf N concentration (Peng *et al.* 1998).

Both wheat and rice crop phenophases are responsive to the environment. Breeding efforts have altered vegetative phase durations in both crops. The genetic factors such as earliness per se loci are absent in rice (Faricelli *et al.* 2009, 2010). Both crops were domesticated in different climates and so differ significantly in their growth conditions; wheat shows appreciably faster growth rate and allocates more biomass to leaves than rice; however, the optimal temperature for biomass production is higher for rice than wheat (Nagai and Makino 2009). While both species significantly contrast in photoperiod sensitivity, the response of developmental processes to optimum temperature is similar in both species and is not affected by either natural selection or artificial breeding (Parent and Tardieu 2012). This would suggest a strong interaction between developmental events and the environment in particular temperature per se.

Both species differ in LAI. Since both crops differ for leaf N content per unit area, they also differ for radiation conversion factor (Mitchell *et al.* 1998). Interestingly, the correlation between leaf N content and grain number vary with genotype and growth conditions in wheat, while it is reported to be independent in rice (Wada and Matsushima 1962; Makino 2011). Since the N concentration in the straw and grain in rice is lower than wheat, the NUE for biomass and grain is higher in rice (Ladha *et al.* 1998). Such differential N levels in the biomass and its allocation influence leaf senescence in both species. Furthermore, awns are absent or short in cultivated rice (Luo *et al.* 2013; Hua *et al.* 2015), while awns have been shown to contribute to net ear photosynthesis in wheat (Evans *et al.* 1972; Sanchez-Bragado *et al.* 2014).

The source–sink regulation is different between two crops. In rice (hybrids), the source capture is relatively higher than that of wheat, while the sink strength is more efficient during grain-filling period. For example, biomass production before stem elongation was higher in rice than in wheat due to high early vigor and CGR (Bueno and Lafarge 2009; Bueno *et al.* 2010). While assimilate partitioning to panicles over other organs is larger in rice after heading (Kato *et al.* 2006; Kumar *et al.* 2006), this has been shown to be limited in wheat. Although the remobilized carbon reserve percentage and its contribution to grain appears higher in wheat than rice, the HI is lower in wheat than in rice probably due to the existence of alternative sinks (Yang and Zhang 2006). Moreover, stem structural differences exist; the width of the stem wall in wheat (0.65 mm) is greater than that in rice (0.45 mm), while stem diameter in wheat (4.7–4.9) is less than the stem diameter of rice (5.3–5.5 mm) (Chuanren *et al.* 2004; Reynolds *et al.* 2009; Wu *et al.* 2011).

By virtue of the growth conditions, the crop management practices and environmental influences on crop growth and development differ between two species. While the conventional crop management practices in wheat have largely been unmodified, in rice, sound management practices have been in practice. Among others, planting patterns, planting density, and spacing have resulted in more open canopies, which increased the overall performance of the rice crop canopy in terms of leaf angle, tiller dynamics, light interception, and photosynthetic rate (Table 1).

A Research Gap Analysis for Future Research Priorities

Both, wheat and rice, crops have been explored in different ways. However, the genetic gains in yields of wheat and rice across the globe are less than 1% per annum. The following opportunities, but not limited to, may be promising to further increase in genetic gains in yields of both crops.

Yield components

Recent gains in crop yields has been achieved through larger panicle size with higher grain number per panicle in rice (Ying et al. 1998), while increased grain number predominantly enhanced grain yields in wheat (Poza et al. 2014; Zhou et al. 2014). Historical data, however, support that grain number (either through extra panicles/spikes or extra grain per panicle/spike) needs to be increased in both crops. In addition, a number of genes important

for yield formation have been identified in both crops (see review, Valluru et al. 2014, table 3). For example, genes controlling leaf and panicle size (SPIKE) and grain assimilate accumulation (*GIF1* and *Rg5*) have been identified in rice (Fujita et al. 2013; Ishimaru et al. 2005). In wheat, structural modification to *AGPase* gene has been proposed to increase starch accumulation in grain (Meyer et al. 2007). Furthermore, *GS3* and *Gn1* controlling grain number and weight have been identified in rice. These genes have largely not been explored in both crops (Valluru et al. 2014).

Harvest index

Increasing HI is not a strong candidate, as it is already high, above 0.5 in high-yielding varieties and sink regulation is also high and effectively expressed in hybrid rice (Ying et al. 1998; Lafarge et al. 2010). In wheat, an average HI reported is 0.45 (Zheng et al. 2011; Xiao et al. 2012). Increasing HI above the current values may lead to high risk of lodging unless plants have a lower center of gravity (i.e., are shorter), but then this would reduce light interception, consequently reducing biomass. More rigid stems involving anatomical changes like increasing concentrations of structural carbohydrates like lignin could be a long-term breeding objective.

Biomass

Increasing biomass accumulation may be a promising avenue in both crops. In rice, hybrids have significantly

Table 1. Trait similarities and differences between wheat and rice.

Trait	Wheat	References	Rice	References
Preanthesis period	Preanthesis period reduced in modern genotypes	Álvaro et al. (2008); Isidro et al. (2011)	Preanthesis period reduced in modern genotypes	Peng et al. (2000)
Earliness per se	Earliness per se locus are present in wheat	Gouis et al. (2011)	Earliness per se locus are reported to be absent in rice	Faricelli et al. (2009); (Faricelli et al. 2010)
LAI	LAI is lower	Acreche et al. (2009); Parry et al. (2011)	LAI is higher	Zheng et al. (2008); Zhang et al. (2009)
RUE	RUE increased in modern cultivars particularly during postanthesis period	Calderini et al. (1997)	RUE increased in modern cultivars	Boschetti et al. (2006)
Awns	Awns are reported to contribute to net ear photosynthesis	Evans et al. (1972); Sanchez-Bragado et al. (2014)	Awns are absent or short in the cultivated rice	Luo et al. (2013); Hua et al. (2015)
Leaf senescence	Leaf senescence is slightly delayed in modern cultivars due to the presence of nonfunctional grain protein content gene	Gregersen et al. (2008)	Indica and Japonica exhibit different leaf senescence patterns, early and late, respectively	Abdelkhalik et al. (2005)

LAI, leaf area index; RUE, radiation use efficiency.

higher aboveground biomass (10–12%) than inbred cultivars (Peng et al. 2008);(Bueno and Lafarge 2009). In wheat, biomass has, on average, a lower genetic gain (0.3), suggesting that biomass production may still be the main way forward to increase yields (Fischer and Edmeades 2010; Sylvester-Bradley et al. 2012). However, the key question that needs to be addressed would be whether the key driver of yield is, biomass accumulation or sink strength? Would higher biomass accumulation induce better sink strength or better sink strength support higher biomass accumulation? A crossing program at CIMMYT that combines high source with high sink traits is showing genetic gains for yield and biomass in international trials, suggesting that source and sink balance is important (Reynolds et al. 2015).

Leaf and crop photosynthesis

Improving TPU is promising in both crops. If sink strength is higher, photosynthate could be exported quicker from the source leaves to the sink to reduce downregulation of photosynthesis. Similarly, improving mesophyll conductance could be promising. Changes in leaf anatomy could facilitate CO₂ diffusion between the leaf compartments to also reduce downregulation of leaf photosynthesis. Further reducing night respiration could be important although few studies report limited diversity for this trait and limited effect on the overall performance (Peraudeau et al. 2015a,b). If the plant could uptake more N (via higher fertilization and/or better root system and/or improved water management for better uptake), with N being more available to fill grain, then so leaf senescence can be delayed and crop photosynthesis maintain for a longer duration. Numerous proposed avenues for enhancing photosynthesis rate in C₃ species are given in Figure 1.

Sink strength

Increasing sink strength through improving panicle/spike architecture could be important. Reducing hormonal (especially ethylene) regulation that delays the filling of basal spikelets could be promising for efficient grain filling. In addition, increasing the role of T6P, as sugar regulator, could facilitate the export of carbohydrates to the panicles/spikes.

Acknowledgments

The authors thank two reviewers for their useful comments.

Conflict of Interest

None declared.

References

- Abdelkhalik, A. F., R. Shishido, K. Nomura, and H. Ikehashi. 2005. QTL-based analysis of leaf senescence in an indica/japonica hybrid in rice (*Oryza sativa* L.). *Theor. Appl. Genet.* 110:1226–1235.
- Acreche, M. M., and G. A. Slafer. 2011. Lodging yield penalties as affected by breeding in Mediterranean wheats. *Field Crops Res.* 122:40–48.
- Acreche, M. M., G. Briceño-Félix, J. A. Martín Sánchez, and G. A. Slafer. 2009. Radiation interception and use efficiency as affected by breeding in Mediterranean wheat. *Field Crops Res.* 110:91–97.
- Aisawi, K. A. B., M. P. Reynolds, R. P. Singh, and M. J. Foulkes. 2015. The physiological basis of the genetic progress in yield potential of CIMMYT spring wheat cultivars from 1966 to 2009. *Crop Sci.* 55:1749–1764.
- Álvaro, F., J. Isidro, D. Villegas, L. F. García del Moral, and C. Royo. 2008. Breeding effects on grain filling, biomass partitioning, and remobilization in Mediterranean durum wheat. *Agron. J.* 100:361.
- Ayeneh, A., M. van Ginkel, M. Reynolds, and K. Ammar. 2002. Comparison of leaf, spike, peduncle and canopy temperature depression in wheat under heat stress. *Field Crops Res.* 79:173–184.
- Berry, P., J. Spink, M. Foulkes, and A. Wade. 2003a. Quantifying the contributions and losses of dry matter from non-surviving shoots in four cultivars of winter wheat. *Field Crops Res.* 80:111–121.
- Berry, P. M., M. Sterling, C. J. Baker, J. Spink, and D. L. Sparkes. 2003b. A calibrated model of wheat lodging compared with field measurements. *Agric. For. Meteorol.* 119:167–180.
- Berry, P. M., R. Sylvester-Bradley, and S. Berry. 2007. Ideotype design for lodging-resistant wheat. *Euphytica* 154:165–179.
- Bertheloot, J., P. Martre, and B. Andrieu. 2008. Dynamics of light and nitrogen distribution during grain filling within wheat canopy. *Plant Physiol.* 148:1707–1720.
- Bishop, D. L., and B. G. Bugbee. 1998. Photosynthetic capacity and dry mass partitioning in dwarf and semi-dwarf wheat (*Triticum aestivum* L.). *J. Plant Physiol.* 153:558–565.
- Bogard, M., M. Jourdan, V. Allard, P. Martre, M. R. Perretant, C. Ravel, et al. 2011. Anthesis date mainly explained correlations between post-anthesis leaf senescence, grain yield, and grain protein concentration in a winter wheat population segregating for flowering time QTLs. *J. Exp. Bot.* 62:3621–3636.

- Borràs-Gelonch, G., M. Denti, W. T. B. Thomas, and I. Romagosa. 2011. Genetic control of pre-heading phases in the Steptoe × Morex barley population under different conditions of photoperiod and temperature. *Euphy* 183:303–321.
- Borràs-Gelonch, G., G. J. Rebetzke, R. A. Richards, and I. Romagosa. 2012. Genetic control of duration of pre-anthesis phases in wheat (*Triticum aestivum* L.) and relationships to leaf appearance, tillering, and dry matter accumulation. *J. Exp. Bot.* 63:69–89.
- Boschetti, M., S. Bocchi, D. Stroppiana, and P. Brivio. 2006. Estimation of parameters describing morpho-physiological features of Mediterranean rice varieties for modelling purposes. *Ital. J. Agrometeorol.* 49:3.
- Botwright, T. L., G. J. Rebetzke, A. G. Condon, and R. A. Richards. 2005. Influence of the gibberellin-sensitive Rht8 dwarfing gene on leaf epidermal cell dimensions and early vigour in wheat (*Triticum aestivum* L.). *Ann. Bot.* 95:631–639.
- Brancourt-Hulmel, M. 2003. Genetic improvement of agronomic traits of winter wheat cultivars released in France from 1946 to 1992. *Crop Sci.* 43:37–45.
- Breseghele, F., O. P. de Moraes, P. V. Pinheiro, A. C. S. Silva, E. Maia de Castro, A. P. de Castro, et al. 2011. Results of 25 years of upland rice breeding in Brazil. *Crop Sci.* 51:914.
- Brisson, N., P. Gate, D. Gouache, G. Charmet, F.-X. Oury, and F. Huard. 2010. Why are wheat yields stagnating in Europe? A comprehensive data analysis for France. *Field Crops Res.* 119:201–212.
- Bueno, C. S., and T. Lafarge. 2009. Higher crop performance of rice hybrids than of elite inbreds in the tropics: 1. Hybrids accumulate more biomass during each phenological phase. *Field Crops Res.* 112:229–237.
- Bueno, C. S., and T. Lafarge. Submitted. Relevant traits for high yield in rice in the tropics as dependent on maturity groups and growing seasons.
- Bueno, C. S., E. Pasquin, B. Tubaña, and T. Lafarge. 2010. Improving sink regulation, and searching for promising traits associated with hybrids, as a key avenue to increase yield potential of the rice crop in the tropics. *Field Crops Res.* 118:199–207.
- Butler, J. D., P. F. Byrne, V. Mohammadi, P. L. Chapman, and S. D. Haley. 2005. Agronomic performance of alleles in a spring wheat population across a range of moisture levels. *Crop Sci.* 45:939.
- Calderini, D. F., M. F. Dreccer, and G. A. Slafer. 1997. Consequences of plant breeding on biomass growth, radiation interception and radiation use efficiency in wheat. *Field Crops Res.* 52:271–281.
- Cañas, R. A., I. Quilleré, A. Gallais, and B. Hirel. 2012. Can genetic variability for nitrogen metabolism in the developing ear of maize be exploited to improve yield? *New Phytol.* 194(2):440–52.
- Cantu, D., B. Yang, R. Ruan, K. Li, V. Menzo, D. Fu, et al. 2013. Comparative analysis of protein-protein interactions in the defense response of rice and wheat. *BMC Genom.* 14:166.
- Carver, B. F., and E. Nevo. 1990. Genetic diversity of photosynthetic characters in native populations of *Triticum dicoccoides*. *Photosynth. Res.* 25:119–128.
- Chuanren, D., W. Bochu, W. Pingqing, W. Daohong, and C. Shaoxi. 2004. Relationship between the minute structure and the lodging resistance of rice stems. *Colloids Surf B Biointerfaces* 35:155–158.
- Cook, M. G., and L. T. Evans. 1983. Some physiological aspects of the domestication and improvement of rice (*Oryza* spp.). *Field Crops Res.* 6:219–238.
- Demotes-Mainard, S., and M.-H. Jeuffroy. 2004. Effects of nitrogen and radiation on dry matter and nitrogen accumulation in the spike of winter wheat. *Field Crops Res.* 87:221–233.
- Dreccer, M. F., G. A. Slafer, and R. Rabbinge. 1998. Optimization of vertical distribution of canopy nitrogen. *J. Crop. Prod.* 1:47–77.
- Dreccer, M. F., M. van Oijen, A. H. C. M. Schapendonk, C. S. Pot, and R. Rabbinge. 2000. Dynamics of vertical leaf nitrogen distribution in a vegetative wheat canopy. Impact on canopy photosynthesis. *Ann. Bot.* 86:821–831.
- Duggan, B. L., R. A. Richards, A. F. van Herwaarden, and N. A. Fettell. 2005. Agronomic evaluation of a tiller inhibition gene (tin) in wheat. I. Effect on yield, yield components, and grain protein. *Aust. J. Agric. Res.* 56:169–178.
- Evans, L. T., J. Bingham, P. Jackson, and J. Sutherland. 1972. Effect of awns and drought on the supply of photosynthate and its distribution within wheat ears. *Ann. Appl. Biol.* 70:67–76.
- Evans, L. T., R. M. Visperas, and B. S. Vergara. 1984. Morphological and physiological changes among rice varieties used in the Philippines over the last seventy years. *Field Crops Res.* 8:105–124.
- Faricelli, M. E., M. Valárik, and J. Dubcovsky. 2009. Control of flowering time and spike development in cereals: the earliness per se *Eps-1* region in wheat, rice, and *Brachypodium*. *Funct. Integr. Genomics* 10:293–306.
- Faricelli, M. E., M. Valárik, and J. Dubcovsky. 2010. Control of flowering time and spike development in cereals: the earliness per se *Eps-1* region in wheat, rice, and *Brachypodium*. *Funct. Integr. Genomics* 10:293–306.
- Fischer, R. 2001. Selection traits for improving yield potential. *Appl. Physiol. Wheat Breed.* 148–159.
- Fischer, R. A., and G. O. Edmeades. 2010. Breeding and cereal yield progress. *Crop Sci.* 50:S85–S98.

- Flexas, J., M. Ribas-Carbo, A. Diaz-Espejo, J. Galmes, and H. Medrano. 2008. Mesophyll conductance to CO₂: current knowledge and future prospects. *Plant, Cell Environ.* 31:602–621.
- Foulkes, M. J., G. A. Slafer, W. J. Davies, P. M. Berry, R. Sylvester-Bradley, P. Martre, et al. 2011. Raising yield potential of wheat. III. Optimizing partitioning to grain while maintaining lodging resistance. *J. Exp. Bot.* 62:469–486.
- Fu, J., and B. Lee. 2012. Changes in photosynthetic characteristics during grain filling of a functional stay-green rice SNU-SG1 and its F1 hybrids. *J. Crop. Sci. Biotechnol.* 11:75–82.
- Fu, J., Y. Yan, and B. Lee. 2009. Physiological characteristics of a functional stay green rice SNU-SG1 during grain filling period. *J. Crop. Sci. Biotechnol.* 12:47–52.
- Fu, J., Z. Huang, Z. Wang, J. Yang, and J. Zhang. 2011. Pre-anthesis non-structural carbohydrate reserve in the stem enhances the sink strength of inferior spikelets during grain filling of rice. *Field Crops Res.* 123:170–182.
- Fujita, D., K. R. Trijatmiko, A. G. Tagle, M. V. Sapasap, Y. Koide, K. Sasaki, et al. 2013. NAL1 allele from a rice landrace greatly increases yield in modern indica cultivars. *Proc. Natl Acad. Sci. USA* 110: 20431–20436.
- Gaju, O., V. Allard, P. Martre, J. W. Snape, E. Heumez, J. LeGouis, et al. 2011. Identification of traits to improve the nitrogen-use efficiency of wheat genotypes. *Field Crops Res.* 123:139–152.
- Gao, J., Y. Han, X. Wang, X. Zhao, Z. Ma, H. Xu, et al. 2011. Canopy temperature difference and the related characteristics at heading stage in rice. *J. Shenyang Agric. Univ.* 4:5–7.
- Garcia, G. A. 2011. Variability of duration of pre-anthesis phases as a strategy for increasing wheat grain yield. *Field Crops Res.* 124:408–416.
- Gent, M. 1995. Canopy light interception, gas exchange, and biomass in reduced height isolines of winter wheat. *Crop Sci.* 35:1636–1642.
- Gent, M., and R. Kiyomoto. 1984. Comparison of canopy and flag leaf net carbon dioxide exchange of 1920 and 1977 New York winter wheats. *Crop Sci.* 25:81–86.
- Gooding, M. J., M. Addisu, R. K. Uppal, J. W. Snape, and H. E. Jones. 2012. Effect of wheat dwarfing genes on nitrogen-use efficiency. *J. Agric. Sci.* 150:3–22.
- Gouis, J., J. Bordes, C. Ravel, S. Faure, S. Praud, N. Galic, et al. 2011. Genome-wide association analysis to identify chromosomal regions determining components of earliness in wheat. *Theor. Appl. Genet.* 124:597–611.
- Graybosch, R. A., and C. J. Peterson. 2010. Genetic improvement in winter wheat yields in the great plains of North America, 1959–2008. *Crop Sci.* 50:1882.
- Gregersen, P. L., P. B. Holm, and K. Krupinska. 2008. Leaf senescence and nutrient remobilisation in barley and wheat. *Plant Biol.* 10:37–49.
- Griffiths, H., and B. R. Helliker. 2013. Mesophyll conductance: internal insights of leaf carbon exchange. *Plant, Cell Environ.* 30:600–616.
- Gutierrez-Rodriguez, M. 2000. Photosynthesis of wheat in a warm, irrigated environment: II. Traits associated with genetic gains in yield. *Field Crops Res.* 66:51–62.
- Horton, P. 2000. Prospects for crop improvement through the genetic manipulation of photosynthesis: morphological and biochemical aspects of light capture. *J. Exp. Bot.* 51:475–485.
- Hua, L., D. R. Wang, L. Tan, Y. Fu, F. Liu, L. Xiao, et al. 2015. LABA1, a domestication gene associated with long, barbed awns in wild rice. *Plant Cell* 27:1875–1888.
- Hubbart, S., S. Peng, P. Horton, Y. Chen, and E. H. Murchie. 2007. Trends in leaf photosynthesis in historical rice varieties developed in the Philippines since 1966. *J. Exp. Bot.* 58:3429–3438.
- Ishimaru, K., T. Kashiwagi, N. Hirotsu, and Y. Madoka. 2005. Identification and physiological analyses of a locus for rice yield potential across the genetic background. *J. Exp. Bot.* 56:2745–2753.
- Ishimaru, K., E. Togawa, T. Ookawa, T. Kashiwagi, Y. Madoka, and N. Hirotsu. 2007. New target for rice lodging resistance and its effect in a typhoon. *Planta* 227:601–609.
- Isidro, J., F. Álvaro, C. Royo, D. Villegas, D. J. Miralles, and L. F. García del Moral. 2011. Changes in duration of developmental phases of durum wheat caused by breeding in Spain and Italy during the 20th century and its impact on yield. *Ann. Bot.* 107:1355–1366.
- Islam, M. S., S. Peng, R. M. Visperas, N. Ereful, M. S. U. Bhuiya, and A. W. Julfikar. 2007. Lodging-related morphological traits of hybrid rice in a tropical irrigated ecosystem. *Field Crops Res.* 101:240–248.
- Karimizadeh, R., and M. Mohannadi. 2011. Association of canopy temperature depression with yield of durum wheat genotypes under supplementary irrigated and rainfed conditions. *Aust. J. Crop Sci.* 5:138–146.
- Kato, M., M. Yokoo, and S. Maruyama. 2006. Dry-matter partitioning and accumulation of carbon and nitrogen during ripening in a female-sterile line of rice. *Plant Prod. Sci.* 9:185–190.
- Katsura, K., S. Maeda, I. Lubis, T. Horie, W. Cao, and T. Shiraiwa. 2008. The high yield of irrigated rice in Yunnan, China: “A cross-location analysis”. *Field Crops Res.* 107:1–11.
- Katsura, K., M. Okami, H. Mizunuma, and Y. Kato. 2010. Radiation use efficiency, N accumulation and biomass production of high-yielding rice in aerobic culture. *Field Crops Res.* 117:81–89.

- Kiniry, J. R., G. McCauley, Y. Xie, and J. G. Arnold. 2001. Rice parameters describing crop performance of four U.S. cultivars. *Agron. J.* 93:1354.
- Koç, M., C. Barutçular, and I. Genç. 2003. Photosynthesis and productivity of old and modern durum wheats in a mediterranean environment. *Crop Sci.* 43:2089.
- Koutroubas, S., and D. Ntanos. 2003. Genotypic differences for grain yield and nitrogen utilization in Indica and Japonica rice under Mediterranean conditions. *Field Crops Res.* 83:251–260.
- Kumar, R., A. K. Sarawgi, C. Ramos, S. T. Amarante, A. M. Ismail, and L. J. Wade. 2006. Partitioning of dry matter during drought stress in rainfed lowland rice. *Field Crops Res.* 98:1–11.
- Ladha, J. K., G. J. D. Kirk, J. Bennett, S. Peng, C. K. Reddy, P. M. Reddy, et al. 1998. Opportunities for increased nitrogen-use efficiency from improved lowland rice germplasm. *Field Crops Res.* 56:41–71.
- Lafarge, T., and C. S. Bueno. 2009. Higher crop performance of rice hybrids than of elite inbreds in the tropics: 2. Does sink regulation, rather than sink size, play a major role? *Field Crops Res.* 112:238–244.
- Lafarge, T., C. Seassau, M. Martin, C. S. Bueno, A. Clément-Vidal, E. Schreck, et al. 2010. Regulation and recovery of sink strength in rice plants grown under changes in light intensity. *Funct. Plant Biol.* 37:413–428.
- Li, H. B., Y. X. Hu, D. Z. Bai, T. Y. Kuang, F. Zhou, and J. X. Lin. 2002. Comparison of chloroplast ultrastructure and 77 Kfluorescence emission spectra between awns and flag leaves in wheat. *J. Chin. Elect. Microsc. Soc.* 21:97–101.
- Li, X. J., H. G. Wang, H. B. Li, L. Y. Zhang, N. Teng, Q. Q. Lin, et al. 2006. Awns play a dominant role in carbohydrate production during the grain-filling stages in wheat (*Triticum aestivum*). *Physiol. Plant.* 127:701–709.
- Li, H., Y. Chen, X. Liang, Y. Lian, and W. Li. 2009. Mineral-nitrogen leaching and ammonia volatilization from a rice-rapeseed system as affected by 3,4-dimethylpyrazole phosphate. *J. Environ. Qual.* 38:2131–2137.
- Long, S. P., X. Zhu, S. L. Naidu, and D. R. Ort. 2006. Can improvement in photosynthesis increase crop yields? *Plant, Cell Environ.* 29:315–330.
- Lopes, M. S., and M. P. Reynolds. 2010. Partitioning of assimilates to deeper roots is associated with cooler canopies and increased yield under drought in wheat. *Funct. Plant Biol.* 37:147–156.
- Lopes, M. S., and M. P. Reynolds. 2012. Stay-green in spring wheat can be determined by spectral reflectance measurements (normalized difference vegetation index) independently from phenology. *J. Exp. Bot.* 63:3789–3798.
- Lü, C. G., J. S. Zou, N. Hu, and K. M. Yao. 2007. Effects of leaf morphological factors on canopy structure and transmission of photosynthetically active radiation in rice. *Jiangsu J. Agric. Sci.* 23:501–508.
- Luo, J., H. Liu, T. Gu, X. Huang, Y. Shangguan, J. Zhu, et al. 2013. An-1 encodes a basic helix-loop-helix protein that regulates awn development, grain size, and grain number in rice. *Plant Cell* 25:3360–3376.
- Makino, A. 2011. Photosynthesis, grain yield, and nitrogen utilization in rice and wheat. *Plant Physiol.* 155:125–129.
- Makino, A., T. Mae, and K. Ohira. 1988. Differences between wheat and rice in the enzymic properties of ribulose-1,5-bisphosphate carboxylase/oxygenase and the relationship to photosynthetic gas exchange. *Planta* 174:30–38.
- Manès, Y., H. F. Gomez, L. Puhl, M. Reynolds, H. J. Braun, and R. Trethowan. 2012. Genetic yield gains of the CIMMYT international semi-arid wheat yield trials from 1994 to 2010. *Crop Sci.* 52:1543.
- Maydup, M. L., M. Antonietta, J. J. Guiamet, and E. A. Tambussi. 2012. The contribution of green parts of the ear to grain filling in old and modern cultivars of bread wheat (*Triticum aestivum* L.): evidence for genetic gains over the past century. *Field Crops Res.* 134:208–215.
- Meyer, R. C., M. Steinfath, J. Lisek, M. Becher, H. Witucka-Wall, O. Törjek, et al. 2007. The metabolic signature related to high plant growth rate in *Arabidopsis thaliana*. *Proc. Natl Acad. Sci. USA* 104:4759–4764.
- Mitchell, P., J. Sheehy, and F. Woodward. 1998. potential yields and the efficiency of radiation use in rice. *IRRI Discuss Pap SEr No 32* 62
- Mohapatra, P. K., R. Panigrahi, and N. C. Turner. 2011. Physiology of spikelet development on the rice panicle: is manipulation of apical dominance crucial for grain yield improvement?. *Advances in Agronomy* 110: 333–359.
- Morgounov, A., V. Zykin, I. Belan, L. Roseeva, Y. Zelenskiy, H. F. Gomez-Becerra, et al. 2010. Genetic gains for grain yield in high latitude spring wheat grown in Western Siberia in 1900–2008. *Field Crops Res.* 117:101–112.
- Muurinen, S., G. A. Slafer, and P. Peltonen-Sainio. 2006. Breeding effects on nitrogen use efficiency of spring cereals under northern conditions. *Crop Sci.* 46:561.
- Nagai, T., and A. Makino. 2009. Differences between rice and wheat in temperature responses of photosynthesis and plant growth. *Plant Cell Physiol.* 50:744–755.
- Nebauer, S. G., B. Renau-Morata, J. L. Guardiola, and R. V. Molina. 2011. Photosynthesis down-regulation precedes carbohydrate accumulation under sink limitation in Citrus. *Tree Physiol.* 31:169–177.
- Nelson, C. 1988. Genetic associations between photosynthetic characteristics and yield: review of the evidence. *Plant Physiol. Biochem.* 26:543–554.
- Nuccio, M. L., J. Wu, R. Mowers, H.-P. Zhou, M. Meghji, L. F. Primavesi, et al. 2015. Expression of trehalose-6-phosphate phosphatase in maize ears improves yield in well-watered and drought conditions. *Nat. Biotechnol.* 33:862–869.

- O'Hara, L. E., M. J. Paul, and A. Wingler. 2013. How do sugars regulate plant growth and development? New insight into the role of trehalose-6-phosphate. *Mol. Plant* 6:261–274.
- Ohsumi, A., A. Hamasaki, H. Nakagawa, H. Yoshida, T. Shiraiwa, and T. Horie. 2007. A model explaining genotypic and ontogenetic variation of leaf photosynthetic rate in rice (*Oryza sativa*) based on leaf nitrogen content and stomatal conductance. *Ann. Bot.* 99:265–273.
- Ortiz-Monasterio, J., K. Sayre, S. Rajaram, and M. McMahon. 1997. Genetic progress in wheat yield and nitrogen use efficiency under four nitrogen rates. *Crop Sci.* 37:898–904.
- Panda, B. B., E. Kariali, R. Panigrahi, and P. K. Mohapatra. 2009. High ethylene production slackens seed filling in compact panicked rice cultivar. *Plant Growth Regul.* 58:141–151.
- Parent, B., and F. Tardieu. 2012. Temperature responses of developmental processes have not been affected by breeding in different ecological areas for 17 crop species. *New Phytol.* 194:760–774.
- Pariasca Tanaka, J., P. Nardi, and M. Wissuwa. 2010. Nitrification inhibition activity, a novel trait in root exudates of rice. *AoB Plants* 2010:plq014.
- Parry, M. A. J., M. Reynolds, M. E. Salvucci, C. Raines, P. J. Andralojc, X.-G. Zhu, et al. 2011. Raising yield potential of wheat. II. Increasing photosynthetic capacity and efficiency. *J. Exp. Bot.* 62:453–467.
- Pasuquin, E., T. Lafarge, and B. Tubana. 2008. Transplanting young seedlings in irrigated rice fields: early and high tiller production enhanced grain yield. *Field Crops Res.* 105:141–155.
- Peng, S. 2000. Single-leaf and canopy photosynthesis of rice. *Redesigning Rice Photosynth. Increase Yield Proc. Workshop Quest Reduce Hunger. Rice Photosynth.* Elsevier, Pp 213–228.
- Peng, S., and A. M. Ismail. 2004. Physiological basis of yield and environmental adaptation in rice. Pp. 72–118 in H. T. Nguyen and A. Blum, eds. *Physiology and biotechnology integration for plant breeding*. CRC Press, New York, Basel.
- Peng, S., K. Cassman, S. Virmani, J. Sheehy, and G. Khush. 1998. Yield potential trends of tropical rice since the release of IR8 and the challenge of increasing rice yield potential. *Crop Sci.* 39:1552–1559.
- Peng, S., R. C. Laza, R. M. Visperas, A. L. Sanico, K. G. Cassman, and G. S. Khush. 2000. Grain yield of rice cultivars and lines developed in the Philippines since 1966. *Crop Sci.* 40:307.
- Peng, S., J. Yang, M. R. C. Laza, A. Sanico, R. M. Visperas, and T. T. Son. 2003. Physiological basis of heterosis and crop management strategies for hybrid rice in the tropics. Pp. 153–170 in S. S. Virmani, C. X. Mao and B. Hardy, eds. *Hybrid rice for food security, poverty alleviation, and environmental protection. Proceedings of the 4th International Symposium on Hybrid Rice, Hanoi, Vietnam, 14–17 May 2002*. IRRI, Los Banos (Phillippines).
- Peng, S., G. S. Khush, P. Virk, Q. Tang, and Y. Zou. 2008. Progress in ideotype breeding to increase rice yield potential. *Field Crops Res.* 108:32–38.
- Peraudeau, S., T. Lafarge, S. Roques, C. O. Quinones, A. Clément-Vidal, P. B. F. Ouwkerk, et al. 2015a. Effect of carbohydrates and night temperature on night respiration in rice. *J. Exp. Bot.* 66:3931–3944.
- Peraudeau, S., S. Roques, C. O. Quinones, D. Fabre, J. Van Rie, P. B. F. Ouwkerk, et al. 2015b. Increase in night temperature in rice enhances respiration rate without significant impact on biomass accumulation. *Field. Crop. Res.* 171:67–78.
- Pinto, R. S., and M. P. Reynolds. 2015. Common genetic basis for canopy temperature depression under heat and drought stress associated with optimized root distribution in bread wheat. *TAG Theor. Appl. Genet. Theor. Angew. Genet.* 128:575–585. doi:10.1007/s00122-015-2453-9.
- Pinto, R. S., M. P. Reynolds, K. L. Mathews, C. L. McIntyre, J.-J. Olivares-Villegas, and S. C. Chapman. 2010. Heat and drought adaptive QTL in a wheat population designed to minimize confounding agronomic effects. *Theor. Appl. Genet.* 121:1001–1021. doi:10.1007/s00122-010-1351-4.
- Pinto, R. S., and M. P. Reynolds. 2015. Common genetic basis for canopy temperature depression under heat and drought stress associated with optimized root distribution in bread wheat. *Theor. Appl. Genet.* 128:575–585.
- Pozo, A., I. Matus, M. D. Serret, and J. L. Araus. 2014. Agronomic and physiological traits associated with breeding advances of wheat under high-productive Mediterranean conditions. The case of Chile. *Environ. Exp. Bot.* 103:180–189.
- Rajaram, S., H. J. Braun. 2008. Wheat yield potential. *in* eds. Reynolds et al. *International symposium on wheat yield potential: challenges to international wheat breeding*. Mexico DF, Mexico.
- Rebetzke, G. J., A. F. van Herwaarden, C. Jenkins, M. Weiss, D. Lewis, S. Ruuska, et al. 2008. Quantitative trait loci for water-soluble carbohydrates and associations with agronomic traits in wheat. *Aust. J. Agric. Res.* 59:891–905.
- Rebetzke, G. J., D. G. Bonnett, and M. H. Ellis. 2012. Combining gibberellic acid-sensitive and insensitive dwarfing genes in breeding of higher-yielding, semi-dwarf wheats. *Field. Crop. Res.* 127:17–25.
- Reynolds, M., F. Dreccer, and R. Trethowan. 2007. Drought-adaptive traits derived from wheat wild relatives and landraces. *J. Exp. Bot.* 58:177–186.

- Reynolds, M., M. J. Foulkes, G. A. Slafer, P. Berry, M. A. J. Parry, J. W. Snape, et al. 2009. Raising yield potential in wheat. *J. Exp. Bot.* 60:1899–1918.
- Reynolds, M., et al. , 2015. Pre-breeding for yield potential traits: summary of international Data from 2nd WYCYT and performance of pipeline material. *in* M. Reynolds et al., eds. Proceedings of the International TRIGO (Wheat) Yield Potential Workshop 2015. CENEB, CIMMYT, Cd Obregon, Sonora, Mexico 24–26th March 2015. CIMMYT, Mexico DF.
- Royo, C., F. Álvaro, V. Martos, A. Ramdani, J. Isidro, D. Villegas, et al. 2006. Genetic changes in durum wheat yield components and associated traits in Italian and Spanish varieties during the 20th century. *Euphytica* 155:259–270.
- Sadras, V. O., and C. Lawson. 2011. Genetic gain in yield and associated changes in phenotype, trait plasticity and competitive ability of South Australian wheat varieties released between 1958 and 2007. *Crop Pasture Sci.* 62:533–549.
- Sadras, V. O., M. P. Reynolds, A. J. de la Vega, P. R. Petrie, and R. Robinson. 2009. Phenotypic plasticity of yield and phenology in wheat, sunflower and grapevine. *Field Crops Res.* 110:242–250.
- Saitoh, K., K. Yonetani, T. Murota, and T. Kuroda. 2002. Effects of flag leaves and panicles on light interception and canopy photosynthesis in high-yielding rice cultivars. *Plant Prod. Sci.* 5:275–280.
- Samonte, S. O. P., L. T. Wilson, J. C. Medley, S. R. M. Pinson, A. M. McClung, and J. S. Lales. 2006. Nitrogen utilization efficiency. *Agron. J.* 98:168.
- Sanchez-Bragado, R., G. Molero, M. P. Reynolds, and J. L. Araus. 2014. Relative contribution of shoot and ear photosynthesis to grain filling in wheat under good agronomical conditions assessed by differential organ $\delta^{13}C$. *J. Exp. Bot.* 65:5401–5413.
- Setter, T. L., E. S. Ella, and A. P. Valdez. 1994. Relationship between coleoptile elongation and alcoholic fermentation in rice exposed to anoxia. II. Cultivar differences. *Ann. Bot.* 74:273–279.
- Setter, T., E. Conocono, J. Egdane, and M. Kropff. 1995. Possibility of increasing yield potential of rice by reducing panicle height in the canopy. I. Effects of panicles on light interception and canopy photosynthesis. *Funct. Plant Biol.* 22:441–451.
- Sharma, R. C., J. Crossa, G. Velu, J. Huerta-Espino, M. Vargas, T. S. Payne, et al. 2012. Genetic gains for grain yield in CIMMYT spring bread wheat across international environments. *Crop Sci.* 52:1522.
- Shearman, V., R. Sylvester-bradley, R. Scott, and M. Foulkes. 2005. Physiological processes associated with wheat yield progress in the UK. *Crop Sci.* 45:175–185.
- Shimoda, S. 2012. Contribution of leaf nitrogen to photosynthetic gas exchange in contrasting rice (*Oryza sativa* L.) cultivars during the grain-filling period. *Photosynthetica.* 50: 387–394.
- Shingaki-Wells, R. N., S. Huang, N. L. Taylor, A. J. Carroll, W. Zhou, and A. H. Millar. 2011. Differential molecular responses of rice and wheat coleoptiles to anoxia reveal novel metabolic adaptations in amino acid metabolism for tissue tolerance. *Plant Physiol.* 156:1706–1724.
- Shiratsuchi, H., T. Yamagishi, and R. Ishii. 2006. Leaf nitrogen distribution to maximize the canopy photosynthesis in rice. *Field Crops Res.* 95:291–304.
- Simpson, R. J., H. Lambers, and M. J. Dalling. 1983. Nitrogen redistribution during grain growth in wheat (*Triticum aestivum* L.). *Plant Physiol.* 71:7–14.
- Sorrells, M. E., M. La Rota, C. E. Bermudez-Kandianis, R. A. Greene, R. Kantety, J. D. Munkvold, et al. 2003. Comparative DNA sequence analysis of wheat and rice genomes. *Genome Res.* 13:1818–1827.
- Subbarao, G. V., O. Ito, K. L. Sahrawat, W. L. Berry, K. Nakahara, T. Ishikawa, et al. 2006. Scope and strategies for regulation of nitrification in agricultural systems—challenges and opportunities. *Crit. Rev. Plant Sci.* 25:303–335.
- Subbarao, G. V., B. Tomohiro, K. Masahiro, I. Osamu, H. Samejima, H. Y. Wang, et al. 2007. Can biological nitrification inhibition (BNI) genes from perennial *Leymus racemosus* (Triticeae) combat nitrification in wheat farming? *Plant Soil* 299:55–64.
- Sylvester-Bradley, R., P. Riffkin, and G. O’Leary. 2012. Designing resource-efficient ideotypes for new cropping conditions: wheat (*Triticum aestivum* L.) in the High Rainfall Zone of southern Australia. *Field Crops Res.* 125:69–82.
- Tabien, R. E., S. O. P. Samonte, and A. M. McClung. 2008. Forty-eight years of rice improvement in texas since the release of cultivar bluebonnet in 1944. *Crop Sci.* 48:2097.
- Taylor, R. D., S. Adachi, T. Ookawa, H. Usuda, and T. Hirasawa. 2011. Hydraulic conductance as well as nitrogen accumulation plays a role in the higher rate of leaf photosynthesis of the most productive variety of rice in Japan. *J. Exp. Bot.* 62:4067–4077.
- Thomas, H., and C. Howarth. 2000. Five ways to stay green. *J. Exp. Bot.* 51:329–337.
- Thorne, G. N., and D. W. Wood. 1987. Effects of radiation and temperature on tiller survival, grain number and grain yield in winter wheat. *Ann. Bot.* 59:413–426.
- Tirol-Padre, A., J. K. Ladha, U. Singh, E. Laureles, G. Punzalan, and S. Akita. 1996. Grain yield performance of rice genotypes at suboptimal levels of soil N as affected by N uptake and utilization efficiency. *Field Crops Res.* 46:127–143.
- Tomas, M., J. Flexas, L. Copolovici, J. Galmes, L. Hallik, H. Medrano, et al. 2013. Importance of leaf anatomy in determining mesophyll diffusion conductance to CO₂

- across species: quantitative limitations and scaling up by models. *J. Exp. Bot.* 64:2269–2281.
- Underdahl, J. L., M. Mergoum, J. K. Ransom, and B. G. Schatz. 2008. Agronomic traits improvement and associations in hard red spring wheat cultivars released in North Dakota from 1968 to 2006. *Crop Sci.* 48:158.
- Valluru, R., M. P. Reynolds, and J. Salse. 2014. Genetic and molecular bases of yield-associated traits: a translational biology approach between rice and wheat. *Theor. Appl. Genet.* 127:1463–1489.
- Vergara, B., and T. Chang. 1985. The flowering response of the rice plant to photoperiod. 4th ed. IRRI, Los Baños.
- Wada, G., and S. Matsushima. 1962. Analysis of yield-determining process and its application to yield-production and culture improvement of lowland rice. LXII. On the mechanisms of determining the number of spikelets. *Proc. Crop. Sci. Soc. Jpn.* 31:23–25.
- Wang, R. F., D. G. An, C. S. Hu, L. H. Li, Y. M. Zhang, Y. G. Jia, et al. 2011. Relationship between nitrogen uptake and use efficiency of winter wheat grown in the North China Plain. *Crop Pasture Sci.* 62:504–514.
- Wang, Z., S. Kang, C. R. Jensen, and F. Liu. 2012. Alternate partial root-zone irrigation reduces bundle-sheath cell leakage to CO₂ and enhances photosynthetic capacity in maize leaves. *J. Exp. Bot.* 63:1145–1153.
- Wassmann, R., S. V. K. Jagadish, S. Heuer, A. Ismail, E. Redona, R. Serraj, et al. 2009. Climate change affecting rice production: the physiological and agronomic basis for possible adaptation strategies. Academic Press, *Advances in Agronomy*, Vol 101. Burlington: Academic Press, 2009, pp.59–122.
- Wojciechowski, T., M. J. Gooding, L. Ramsay, and P. J. Gregory. 2009. The effects of dwarfing genes on seedling root growth of wheat. *J. Exp. Bot.* 60:2565–2573.
- Wu, L., Z. Liu, J. Wang, C. Zhou, and K. Chen. 2011. Morphological, anatomical, and physiological characteristics involved in development of the large culm trait in rice. *Aust. J. Crop Sci.* 5:1356–1363.
- Xiao, Y. G., Z. G. Qian, K. Wu, J. J. Liu, X. C. Xia, W. Q. Ji, et al. 2012. Genetic gains in grain yield and physiological traits of winter wheat in Shandong Province, China, from 1969 to 2006. *Crop Sci.* 52:44.
- Yadav, U. P., A. Ivakov, R. Feil, G. Y. Duan, D. Walther, P. Giavalisco, et al. 2014. The sucrose-trehalose 6-phosphate (Tre6P) nexus: specificity and mechanisms of sucrose signaling by Tre6P. *J. Exp. Bot.* 65:1051–1068.
- Yamauchi, M. 1994. Physiological bases for higher yield potential in F1 hybrids. Pp. 71–80 in S. S. Virmani, ed. *Hybrid rice technology: new developments and future prospects*. International Rice Research Institute, Los Baños, Philippines.
- Yang, J., and J. Zhang. 2006. Grain filling of cereals under soil drying. *New Phytol.* 169:223–236.
- Yang, W., S. Peng, R. C. Laza, R. M. Visperas, and M. L. Dionisio-Sese. 2007. Grain yield and yield attributes of new plant type and hybrid rice. *Crop Sci.* 47:1393.
- Yeo, M. E., A. R. Yeo, and T. J. Flowers. 1994. Photosynthesis and photorespiration in the genus *Oryza*. *J. Exp. Bot.* 45:553–560.
- Yin, X., M. J. Kropff, P. K. Aggarwal, S. Peng, and T. Hone. 1997a. Optimal preflowering phenology of irrigated rice for high yield potential in three Asian environments: a simulation study. *Field Crops Res.* 51:19–27.
- Ying, J., S. Peng, Q. He, H. Yang, C. Yang, R. M. Visperas, et al. 1998. Comparison of high-yield rice in tropical and subtropical environments: I. Determinants of grain and dry matter yields. *Field Crops Res.* 57:71–84.
- Yuan, W., S. Peng, C. Cao, P. Virk, D. Xing, Y. Zhang, et al. 2011. Agronomic performance of rice breeding lines selected based on plant traits or grain yield. *Field Crops Res.* 121:168–174.
- Zhang, W.-H., and M. Kokubun. 2004. Historical changes in grain yield and photosynthetic rate of rice cultivars released in the 20th century in Tohoku region. *Plant Prod. Sci.* 7:36–44.
- Zhang, Y., Q. Tang, Y. Zou, D. Li, J. Qin, S. Yang, et al. 2009. Yield potential and radiation use efficiency of “super” hybrid rice grown under subtropical conditions. *Field Crops Res.* 114:91–98.
- Zhao, M., T. L. B. Acuña, H. R. Lafitte, G. Dimayuga, and E. Sacks. 2008. Perennial hybrids of *Oryza sativa* × *Oryza rufipogon* Part II. Carbon exchange and assimilate partitioning. *Field Crops Res.* 106:214–223.
- Zheng, B., L. Shi, Y. Ma, Q. Deng, B. Li, and Y. Guo. 2008. Comparison of architecture among different cultivars of hybrid rice using a spatial light model based on 3-D digitising. *Funct. Plant Biol.* 35:900–910.
- Zheng, T. C., X. K. Zhang, G. H. Yin, L. N. Wang, Y. L. Han, L. Chen, et al. 2011. Genetic gains in grain yield, net photosynthesis and stomatal conductance achieved in Henan Province of China between 1981 and 2008. *Field Crops Res.* 122:225–233.
- Zhou, B., Á. Sanz-Sáez, A. Elazab, T. Shen, R. Sánchez-Bragado, J. Bort, et al. 2014. Physiological traits contributed to the recent increase in yield potential of winter wheat from Henan Province, China. *J. Integr. Plant Biol.* 56:492–504.
- Zhu, X. G., S. P. Long, and D. R. Ort. 2010. Improving photosynthetic efficiency for greater yield. *Ann. Rev. Plant Biol.* 61:235–261.