

DEVELOPMENTAL PROCESS IN MENTAL HANDICAP:

A Generative Structure Approach

by

Geraint Wyn Ephraim

Department of Psychology. Brunel University

January. 1982.

ABSTRACT

A radical argument is presented that it is plausible to look at the condition of mental handicap as entailing dynamic cognitive processes which may be available to some degree of therapeutic intervention at a fundamental level.

An overview of some broad aspects of mental handicap is presented and it is argued that much of the subject of mental handicap is based on assumptions which may not be justified.

On the assumption that in normal infancy play is a powerful medium for promoting developmental change, aspects of the mentally handicapped child's inability to play is examined and discussed. This is done by adopting the Piagetian notion of decentration and showing how the concept has explanatory value for looking at change in the severely, or profoundly mentally handicapped child. A model of aspects of the process is developed and implemented as a computer simulation. This model entails the processes of "Integration and Differentiation" of hierarchical chunks.

The prospects and usefulness of a developmental curriculum as a framework within which to work with the profoundly and severely mentally retarded is discussed. The notions of Integration and Differentiation are applied to systems of sensori-motor competence and presented as a candidate for a curriculum. A presentation of the Uzgiris & Hunt scales serves to provide the user with the means to understand where the child is "at" in the curriculum.

The computer simulation is further developed to show how it could be extended to provide explanations for the effects of success and failure upon developmental process. The model provides an insight into the nature of stereotypy and the implications of the model are explored in a therapy undertaken with a mentally handicapped and withdrawn child. The relationship between the understanding gained here and the processes of normal mothering is introduced.

The theme of the mothering process is developed and explored as a means of providing the mentally handicapped child with the experience of success that section 3 suggests is the means for promoting change. This is demonstrated via several case accounts. The transactional interface between the intractable organic and the potentially more plastic cognitive/social process is tentatively explored by a discussion of "eye contact". Finally an evaluative framework for the possible implications of the work are discussed.

PREFACE

The work I present in this thesis began with a preoccupation with the nature of structural psychological change that I had acquired as an undergraduate. I had the opportunity to develop this preoccupation when I began work at the department of psychology at Leavesden Hospital, for there lived some 150 mentally handicapped children, few of whom had any language. Language acquisition was an example par excellence of the type of structural change that I was interested in.

Although my interest was in language acquisition per se, in trying to answer the question "Why can't these children talk?" it soon became apparent that a more useful question to ask from my perspective was "Why can't these children play?" I felt that were it possible to answer this question then it might be possible to enable the same sort of acquisitional process that operates in normal children. This thesis represents my attempt to understand the problem of playlessness.

During the course of this enterprise I have become increasingly aware that this work was not a solitary individualistic effort and that the resulting thesis is a culmination of the influences and joint efforts of many people.

I would like to express my warm thanks to Patrick Humphreys for his considerable advice, help, and guidance over a number of years; Roger Ramsden for making the project possible and for his continual support over the years; and Hywel Francis and his staff at Springfield School for adopting me as their "tame"

psychologist. Particularly I would like to thank Chris Woods, who provided the material for "Candy" and the structured play, Denise Wallace and Marian Davies for their work with Judy - Marian was also involved in the "mothering" project.

Many other have helped; Brenda Nicholls provided patient secretarial support; Gerry Choo and Ayleen Wishuda provided computer help when otherwise I would have despaired; the Technicians at Brunel Psychology department have, with good humour, provided invaluable support; others, too numerous to mention, have listened patiently and supportively and provided invaluable feedback about my enterprise.

Finally I should mention Rosemary and Growly for providing a "background of safety" and the children of Leavesden for teaching me so much.

It is customary for authors to absolve all those who have helped them from responsibility for errors etc. However, since this enterprise is a really a group effort, responsibility for errors, misconceptions, etc., should be shared by all those involved.

OVERVIEW.

In this work I shall be presenting a tentative and radical approach to understanding mental handicap. I shall be arguing that it is plausible to look at the condition as entailing dynamic cognitive processes which may be available to some degree of therapeutic intervention at a fundamental level.

In Chapter 1 (Introduction) I shall present an overview of some broad aspects of mental handicap and argue that much of the subject of mental handicap is based on assumptions which may not be justified.

In section 1 (Chapters 2,3,& 4), operating with the assumption that in normal infancy play is a powerful medium for promoting developmental change, I shall examine aspects of the mentally handicapped child's inability to play. I do this by adopting the Piagetian notion of decentration and showing how the concept has explanatory value for looking at change in the severely, or profoundly mentally handicapped child. I develop a model of aspects of the process and present an implementation of the model as a computer simulation. This model entails the processes of "Integration and Differentiation".

In section 2 (Chapters,5,6,&7) I examine the prospects and usefulness of a developmental curriculum as a framework within which to work with the profoundly and severely mentally retarded. I develop the notions of Integration and Differentiation (as developed in section 1) as applying to systems of sensori-motor

competence, and present this as a candidate for the curriculum. I then describe a presentation of the Uzgiris & Hunt scales (Appendix 1) which are intended to provide the user with the means to understand where the child is "at" in the curriculum.

In section 3 (Chapters, 7,8,&9.) I take up again the model developed in section 1, and show how it can be extended to provide explanations for the effects of success and failure upon developmental process. The model provides an insight into the nature of stereotypy and the implications of the model are explored in a therapy undertaken with a mentally handicaped and withdrawn child. The relationship between the understanding gained here and the processes of normal mothering is introduced.

Finally, in section 4 (Chapters 10,11, & 12) the theme of the mothering process is developed and explored as a means of providing the mentally handicaped child with the experience of success that section 3 suggests is the means for promoting change. This is demonstrated via several case accounts. The interface between the intractable organic and the potentially more plastic cognitive/social process is tentatively explored by a discussion of "eye contact". The final chapter evaluates and explores the possible implications of the work.

CHAPTER 1...LOOSENING UP

The gate porter of a large institution for the mentally handicapped once said to me, "You can't put in what God left out". This remark seems to encapsulate a whole range of assumptions made about the nature of mental handicap and the plight of the mentally handicapped person. These assumptions are versions of the basic notion that the condition is permanent and not amenable to change.

The aim of this work is to entertain the possibility that the pessimism is unjustified and to present a plausible and certainly optimistic attempt at understanding what is mental handicap. To say that an explanation is plausible is not to say that it is the only explanation, let alone a correct explanation. However, when such an explanation is given a serious hearing (assuming it is worth a hearing) its faults and deficits may prompt the reader to set about making his or her own explanations.

I believe that attempts to promote understanding of mental handicap in terms of pathologies of functional processes will serve to generate therapeutic practices which will at least reduce the severity of the conditions which come under the umbrella of the term "mental handicap".

I do not claim that mental handicap is curable but it is worth bearing in mind that the use of the word "curable" is a statement about the state of professional knowledge, rather than information about the condition. (See

Cantor, 1961)

Pessimism and the chronic psychiatric patient. One of the implications of this is that understanding mental handicap entails not just understanding the plight of the individual person but extends to understanding the social nexus of which his plight is a focus. This nexus includes his family, of which more later, but also the knowledge and practice of the various professional groups who specialise in mental handicap and also the culture within which they operate.

This statement may be further illuminated by considering how the invidious influence of pessimism operates in the neighbouring field of general psychiatry. Clare Benedek(1980) makes a useful distinction between what she terms the "fast flow" Psychiatry of the outpatient clinic and admission ward and the "slow flow" psychiatry of the chronic back ward. In fast flow psychiatry the patient is seen as undergoing change and his pathology, at one level, has a beginning, a middle, and an end. He tends to get better. His illness may re-occur but he is seen as being changeable. In the slow flow psychiatry of the back ward the patient is seen as being stuck in a timeless chronicity (Jones 1974) where there is no change expected. Yet if such patients are lucky enough to be placed in a different setting in which it is assumed that change will occur, all else being equal, the patient will change and often very dramatically get better.* The

*For instance, the self care unit at Shenley hospital, Herts, serves to promote the successful discharge of institutionalised patients by voluntary placement in an unstaffed setting where they contract to have concrete plans for employment etc. within a six month period.

new setting may not necessarily have a focused therapeutic procedure but the effect of optimism, the assumption that change is possible, is subtly therapeutic.

Within the chronic regime any attempt to produce change may be anathema. Many tales are told of various programs introduced by doctors, nurses, or psychologists, which have been sabotaged either deliberately, or subtly and unconsciously.

The same tales of sabotage are recounted in hospitals for the mentally handicapped. The Jay report (1979) makes optimistic proposals about the possibility that mentally handicapped people can lead full and relatively independent lives by being placed within setting which expect change. These proposals, whatever their merit, have been the subject of very strong attacks from some members of the nursing profession, and the content of the attacks tends to emphasise the dependence and chronicity of the mentally handicapped person. Ryan and Thomas (1980) provide a wealth of examples of such attitudes.

Cultural assumptions. Historically the issue of pessimism and optimism goes back at least to medieval times. In the days of Edward the Confessor there was a legal necessity to differentiate between lunacy and idiocy. Lunacy was seen as a temporary state and the lunatics' property was managed for him for the duration of his illness at the end of which time his property and status was ceremoniously handed back to him. The idiot on the other hand was seen as being in a state of permanent irresponsibility and his property was permanently taken over. The

effect of this was to deprive him of his status as a member of his society (Louek.1980).

At the turn of this century the issue in this country was clouded by strong moralistic attitudes. Whilst this is really a side issue it is worthy of comment. Consider the following quote.

The social and economic burdens of uncompllicated feeble mindedness are only too well known. The feeble minded are a parasitic predatory class, never capable of self support or of managing their own affairs. The great majority ultimately become public charges in some form. They cause unutterable sorrow at home and are a menace and danger to the community. Feeble minded women are almost invariably immoral and if at large usually become carriers of venereal diseases or give birth to children who are as defective as themselves.....Every feeble minded person, especially the high grade imbecile, is a potential criminal needing only the proper environment and opportunity for the expression of his criminal tendencies. (Fernald 1912 - quoted by Sarason and Doris, 1969)

It is curious that a condition of "intellectual inferiority" produces such a strong moralistic outburst in a professional person, albeit 70 years ago. It is especially interesting that the most dangerous members of this group are those who are borderline cases and who could potentially cross the boundary and become one of us. (c.f. Douglas 1966). It is also interesting to note that many of the attitudes expressed by Fernald are not uniquely addressed to mental handicap. Negroes and other minority groups receive very similar descriptions. Fernald's statement may be extreme but it still exists today in various forms. A benign version of the attitude is that they are "just like children". Here again the same statement could have been uttered by a benign plantation owner. The word "children"

has connotations of lack of moral judgement and a need for externally imposed moral structures, without which "normal" society is in danger of being polluted. The belief that certain minority groups are "constitutionally inferior" and constitute a danger to normal society underlies, I believe, much of the pessimism associated with mental handicap.

The Politics of Intelligence. The Eugenics movement, fearful of the genetic deterioration of "normal" society, believed that superior intelligence could be bred, and consequently had a vested interest in the existence of intelligence as a unitary and heritable trait. This belief was manifest in the concept of "G", the factor of general intelligence. The dark side of the Eugenics movement was manifest in the need to prohibit marriage in people of low intelligence, especially since it was assumed that they were prolific breeders. Like the negro, the mentally handicapped were seen to possess considerable virility and fecundity. Even today marriage amongst the mentally handicapped is a rare event, discouraged even to the extent of needing a psychiatrist's consent in most big institutions. It may be argued that the discouragement is a necessary protection for the children of such marriages, since the partners may not be fit parents. In many cases such an argument may be valid but the issue carries with it the undercurrents of genetic danger to the population. In the 1900's when the eugenic movement held some sway both in this country and in the United States, the Parisian authorities were mindful of the need to identify the educationally backward. The problem was given to Binet, who in

due course produced the first intelligence scale. The existence of a means of measuring abilities on an interval scale, coupled with a vested belief in a heritable general factor of intelligence was the basis upon which the I.Q. movement grew. The politics of intelligence, in the form of the nature/nurture debate produced some spectacular controversy since the debate inevitably focussed on racial issues. The debate has now subsided for the present and many people now believe the nature/nurture dichotomy to be inappropriate. {However see Kamin (1977)}. As Hebb (1949) put it. "intelligence is 100% nurture and 100% nature". Notwithstanding the present state of the debate, I suspect that most people in our culture believe in the genetic argument and believe in the genetic transmission of specific skills. Such lore is often expressed in statements of the form, "I don't understand where he gets it from, no one else in the family is artistic!".

Mental handicap is part of our culture and the politics of intelligence operates in this field too. Yet there is no public controversy over the nature of the condition. The assumptions with which lay people and professionals operate have remained implicit and have not been subject to public scrutiny. This lack of debate may be surprising in view of the policies of recent years whereby the mentally handicapped person is seen as being entitled to a place in his community and is encouraged to be an independent citizen. {"Better Services for the Mentally Handicapped" (1971)}. It may be the case that our cultural assumptions about mental handicap are changing but I suspect that

the truth is closer to the idea that our culture is developing a benign and compassionate tolerance of people who are still seen as being constitutionally inferior although they may no longer be seen as quite so dangerous. That is attitudes are changing rather than assumptions. The media, especially television, has given increasing coverage to the topic of mental handicap invariably presenting the plight of the mentally handicapped person in a sympathetic manner. Within the subcultures of our institutions for the mentally handicapped the politics are much closer to the surface and there is some considerable resistance to the possibility of change.

When we look at specialised wards or units we often find a perverse pride amongst staff in the intractability of the people catered for. Where a dramatic change is effected with a particular mentally handicapped person it often happens that that person is not only recategorised but that his original placement in that category is questioned. "That child wasn't brain damaged, he was autistic" is a not uncommon response to change. In a different setting it may take the form "That child was not a true autist".

The person who chooses to work with the mentally handicapped, whatever his profession, tends to acquire considerable social respect. However, this respect conveys a sham status since he is likely to be poorly paid whilst arousing the suspicious admiration of his fellow citizens. "I couldn't do what you are doing " expresses admiration but at the same time denigrates those working in the field. (G.E.Jones (op.cit.) cites similar

contradictory messages given to psychiatric workers who, despite the remit given to them to provide care to the psychiatrically ill by our society, are seen as being libertarian to the point of being eccentric and acquire the stigma of those in their care.) By investing value in the intractability of his clients, the worker bolsters his own status and denies the contradictions presented by his fellow citizens.

Classification by intelligence. In the United States, mental handicap is defined as a retardation in development and bodies such as the National Mental Handicap Development Group (1978) adopt similar definitions. In contrast British administrative practice continues to use intelligence as a basis for classification upon which services are based. For instance, since 1971, mentally handicapped children are classified as being "severely retarded (I.Q.< 50)" and are placed in E.S.N.(S) schools {Educationally subnormal(severe)} or they are classified as being E.S.N.(M) {moderate} (I.Q.>50,<70) and placed in E.S.N.(M) schools.

If we look at the parents of children in E.S.N.(M) schools we find that, as a sample, they are not representative of the population as a whole. They are predominately of low socio-economic status and are usually identified as problem families. In contrast the parents of E.S.N.(S) school children seem to be more representative of the total population. The ratio of numbers of middle class parents to number of working class parents being approximately the same as the population at large. (Kushlik and

Blunden, 1974)

One possible implication of this is that, assuming a unidimensional model of intelligence, the intelligence of the population does not follow the theoretical Gaussian curve but is based on two overlapping distributions.(see fig.1.1). One population expresses the normal variation in intelligence, the second expresses the variation of intelligence in brain damaged or genetically aberrant individuals.

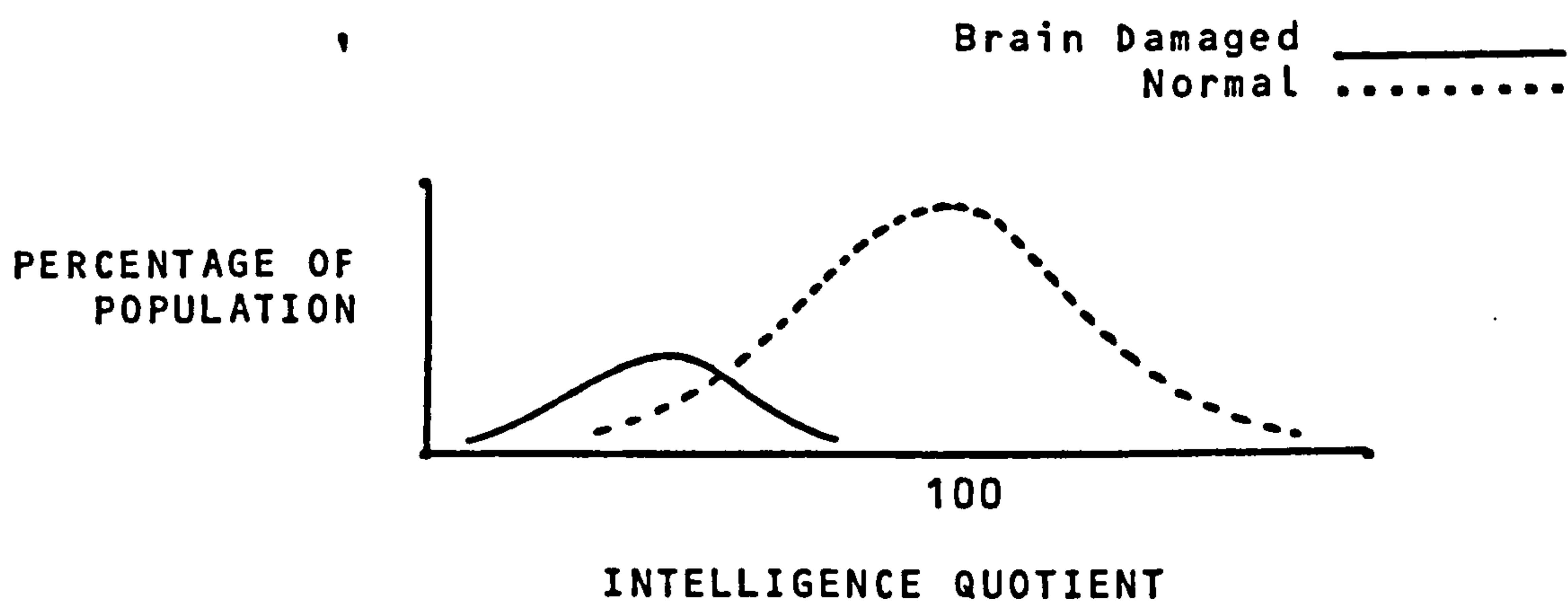

Fig 1.1 Hypothesised bimodal nature of population I.Q distribution.

The picture is not so simple however. In the case of Down's syndrome, for instance, we find that the distribution of intelligence is much greater and some Down's children are of normal intelligence.

Kushlick (1968) points out that if we predict, using the Gaussian distribution, the percentage of the school age population whose I.Q.'s are between 50 and 74 , we discover that

Less than half attend the schools provided for their needs. It seems that many thousands of E.S.N.(M) children are attending ordinary schools. They may be seen as slow learners, but they are not labelled as mentally handicapped. It is only when a particular child presents management problems for his teacher that he may be referred for assessment. It would seem that the E.S.N.(M) child is labelled as such for social behavioural reasons, not for intellectual reasons. His I.Q. only becomes an issue when he fails to function socially.

A similar argument could be applied to the population of a large institution for the mentally handicapped. People are usually admitted to subnormality hospitals, not for reasons of intellectual deficit but for reasons of social maladjustment. The persons' intelligence only becomes an issue when the specific nature of his placement is considered, and even then it is rarely that an I.Q. test is administered, and even then it is often a post hoc justification for the placement that has already taken place. Indeed there are a few young people in subnormality hospitals who are of normal intelligence but who function at a lower level because of emotional/social reasons. Such cases almost invariably have a history of a childhood spent in care, manifesting increasing antisocial behaviour until they are placed in the interim security provisions of a subnormality hospital. The institution is often perceived as a "bad guy" in these instances, particularly by some liberal members of the caring professions, but this is a naive perception and if the institution is to be criticised it because it is not strong

enough to say "no" to the very strong pressures put upon it by the various agencies to admit such people.

Suggesting that those children placed in E.S.N.(M) schools are there because of social-familial factors does not in itself mean that intelligence is not an issue. The fact remains that they are slow learners and the assumption usually made is that this is for intellectual/genetic reasons. This imposes an intractability upon the problem.

Nature, an overstated case. R.B.McCall(1976) and S.Scarr-Salatapek(1976) independently present arguments which seriously question the evidence for intelligence being a function of genetic variability. Evidence for intelligence being genetic usually rests upon three predictions.

a) If a genetic factor is operating then it will operate throughout a persons' life. It follows that infant abilities will be predictive of adult abilities.

b) The more a group of people have genetically in common then the greater the tendency for them to have similar intelligence. In practice this proposition focuses on the differences in I.Q. correlations in siblings, non identical, and identical twins.

c) The third issue is in effect a corollary of (b) and focusses on the proposition that the less two groups have genetically in common the more dissimilar will be their I.Q.'s. In practice this argument manifest itself as the proposition that different ethnic groups have intrinsically different I.Q.'s and it is this issue which

has dominated the I.Q. controversy

Contrary to the first prediction infant ability is a very poor predictor of adult I.Q. (McCall et al. 1972) and socioeconomic status provides a far better predictor (I.Q. / S.E.S. correlations range from .25 to .50) There are two exceptions to this. Cameron et al.(1967) found that the precocious onset of speech in female infants correlated at .76 with verbal I.Q. at the age of 26.

Honzik et al. (1965) point out that low developmental scores in infancy do predict low adult intelligence, but since low developmental scores are those obtained by brain damaged or genopathic children it is hardly surprising that the pathology is manifest throughout a persons' life.

The second prediction is usually taken to be supported by data derived from twin studies, where I.Q correlations between siblings, non identical, and identical twins are compared. In various studies (see McCall et. al.,op.cit.) the correlations quoted are within the ranges given in table 1.1.

Table 1.1	Monozygotic Twins	Dizygotic Twins	Siblings
I.Q. Correlations	.81-.85	.55-.74	.15-.37

The first anomaly about these figures is that the sibling and dizygotic twin correlations are so different. Given two groups with the same proportion of genetic similarity (50%) it would be expected that the intercorrelations would be the same

for the two groups.

The second anomaly is based on a more lengthy argument. In the collaborative Perinatal Project, Nicholson and Broman (1974) found that there was a tendency for serious retardation to be 6 to 9 times higher in twins than in single births. (They assumed a very conservative definition of retardation such that 1 in 10,000 children would be retarded if the distribution of scores was normal). They also found that the incidence of retardation was twice as likely in monozygotic twins than it was in dizygotic twins.

This suggests that the monozygotic twins' high correlations are an expression of a sizable number of the sample being in some way organically damaged. If the correlations are recomputed having discarded those subjects who are of very low intelligence then the difference in correlation between monozygotic and dizygotic twins vanishes!

McCall explains the difference between twin correlations and sibling correlations by arguing that the high twin correlations are a function of twins being tested on the same day and by the same psychologist, whereas siblings are likely to be tested at different times and possibly by different psychologists.

An additional explanation suggested by Nicholson and Broman is that twins share the same prenatal environment and that it is this common experience which contributes to their relatively high intellectual intercorrelation.

I doubt that this is the end of the story. As children get older so their verbal I.Q.'s tend to approach those of their biological parents. (Honzik 1957). This suggests that language is involved in the issue of heritability though it does not necessarily follow that language is innate in the sense it seems that Chomsky suggests. Whatever the nature of intelligence it is plausible and optimistic to maintain a position which emphasises the plasticity of intelligence. Such a position is supported by the epidemiology of mental handicap and allows for considerable optimism as far as the moderately handicapped are concerned, together with the rider that it is a position which places a great deal of responsibility on the agencies of our society.

Where does this leave the severely and profoundly handicapped, the genetically aberrant and the brain damaged? Are there means of understanding their problems which would allow us some optimism, however cautious?

Transactional Models of Infancy

In a study of the effects of perinatal anoxia on later intellectual ability, Sameroff and Chandler (1975) propose a "transactional model". Their work supports assertions of the following nature.

An anoxic baby born to a well adjusted mother enjoying reasonable material security would probably not suffer any long term effects, but, in contrast the same baby born to an anxious or depressed mother suffering from considerable material hardships would suffer some long term effects in the form of some

intellectual deficit.

In order to account for such differences Sameroff and Chandler reject simple unitary or even additive models as being inadequate and propose that a transactional model, though complex and difficult to handle, is necessary to explain such phenomena.

The transactional model emphasises the dynamics of the relationship between mother and damaged infant and entails recognising that the damage will have an effect on the mother. The extent of the effect is dependent on her psychological state. The mother, as affected by her baby will in turn affect the baby through the way she relates to him.

The thesis presented here operates within the transactional framework and the basic assertion which I shall explore could be expressed thus..

A baby born brain damaged or suffering from some genetic anomaly is not necessarily mentally handicapped per se. The handicap is a style of relating to the world which restricts adaptive growth, and this style develops from the interplay between the organic dysfunction and the child's environment. The organic dysfunction then is seen, not as a static absence or lack of capacity but as a set of functional disorders dynamically related to other functioning parts which are localised in the child, in his parents, in the inanimate world, and in the culture of which he is part. This system of interrelationships is not seen as being intractably fixed but is seen as being

potentially plastic.

If there is any basis for such an assertion then by beginning to understand such a system we can entertain the feasibility of engaging in therapy with the profoundly handicapped.

CHAPTER 2.....PLAYLESSNESS

Bernie is a strong handsome 16 year old boy who lives on a ward of a large subnormality hospital. He is an extremely helpful member of his community. His homecraft skills would meet the approval of the most fastidious matron. After meal times he enjoys sweeping the dining room floor, wiping table tops and putting chairs in order. He is industrious and has a very high standard of personal neatness and cleanliness.

However, Bernie has very little language. Except in the swimming pool he does not play. A teacher who has known him for the past 10 years remembers that he played for a short time with a toy bus on a sloping plank.

On one occasion the school was reorganised. Following this Bernie spent a week trying to reinstall his old teacher into the classroom. Having finally accepted his new teachers' stubbornness Bernie turned his attention to his classmates, half of which were new to the class. Bernie dealt with the interlopers by shepherding them into a corner of the classroom and erecting a barricade of chairs around them. He persisted in this exercise for several days before finally giving in.

During a coach outing to a nearby town along a route which he had travelled only a few times previously, Bernie anticipated several junctions by leaning over the driver and operating the indicator switch appropriately.

His I.Q is around 40, but this tells us very little about

him. It would seem though, given his behaviour during the outing, that he can learn some very complex relationships very rapidly. His selfcare standards are high. Although he has considerable dignity and is rather aloof, he enjoys adult company, so he doesn't really appear to be autistic. Yet he has little language and does not play.

Let's speculate about how Bernie makes sense of the world. His use of language is very limited, so that he could be compared to a normal toddler. But Bernie knows a great deal more than the toddler, having had a great deal more experience.

The toddler, when he acquires language, not only acquires a means of communicating with others but also a different means of structuring what he knows about his world. Indeed during his 18 months or so he has developed successive ways of understanding and relating to his world, each more comprehensive and flexible than the last. In Piagetian theory such means are typified as structures inasmuch as a child's behaviour in a given context is a function of the interaction between the child's memory and the situation within which he operates. His memory is not an amorphous collection of previous sensations but serves to organise what he looks at, select appropriate actions, etc. His memory then serves to organise the ways in which the child relates to a particular experience. As a result of this interaction the memory is revised such that his approach to a similar situation will be appropriately modified.

It would seem that Bernie somehow got stuck with a

particular structure and during his development he learnt to use this particular structure to carry far more information than do most children before developing a new, more powerful and flexible structure. For Bernie to change his model entails that he must restructure all the information he has acquired within the structure he has been evidently been using for most of the past 18 years, which is a mammoth task. If Bernie's world behaves in a way that does not fit in with his model then it is far easier for him to actively change his world to fit into his model than to change his model to accomodate the changeable world.

This reluctance to restructure seems to underly his inability to acquire language. Intuitively it seems plausible to suggest that this "stuckness" has something to do with his inability to play.

Every mentally handicapped child is different, and Bernie is certainly enigmatic, yet his "stuckness", his inability to play seems to typify the problems of the severely and profoundly mentally handicapped.

Whilst there is no necessity for mental handicap to be defined in terms of an inability to play, playlessness is a common feature of such children. Even the "brighter subnormal" child's play seems to lack the sparkle and adventure of the normal child.

Playlessness is such a prominent feature of the mentally handicapped that understanding playlessness may help us to under-

stand what is the nature of mental handicap.

Cups and lettuce leaves

Candy is 13 years old, and is seriously retarded in her development. When presented with a cup she picks it up and brings it to her mouth. By so doing she discovers whether there is something to drink or not.

We can describe how she responds to a "cup on the table" situation through a flowchart (Fig 2.1).

Flowcharts are a means of writing down a set of rules. If we wish to, we can use a flowchart to attempt to describe something by means of a set of rules which, if obeyed, will reproduce either a) the object of our description, or b) a representation of the object. Flowcharts use the convention of a pathway to be followed and additionally employ the following devices to represent a set of rules..

- 1) A starting point, usually represented as... START
- 2) A means of knowing the sequence to follow ... given by arrows
- 3) Instructions as to which direction to take if the pathway bifurcates..... enclosed in a lozenge shape.
- 4) Instructions for actions to be operated before continuing along the pathway.... enclosed in a rectangle.
- 5) Instructions to leave the pathway when the procedure is complete, usually represented as.. END or EXIT

We are of course making an assumption that Candy is employing such a set of rules but by describing Candy's behaviour

thus we can begin to understand how her behaviour developed. Presumably, when Candy first began to drink from a cup presented to her she discovered that if she continued to drink from the cup a point was reached when the action of drinking produced no results.(i.e. The cup was empty) So it was useless to carry on drinking. So, from her point of view, whether a cup contained something or not was determined by whether drinking was successful or not. As her abilities developed she learnt how to reach for and pick up the cup. This sequence of actions then preceded the action of drinking as is shown in fig 2.1.

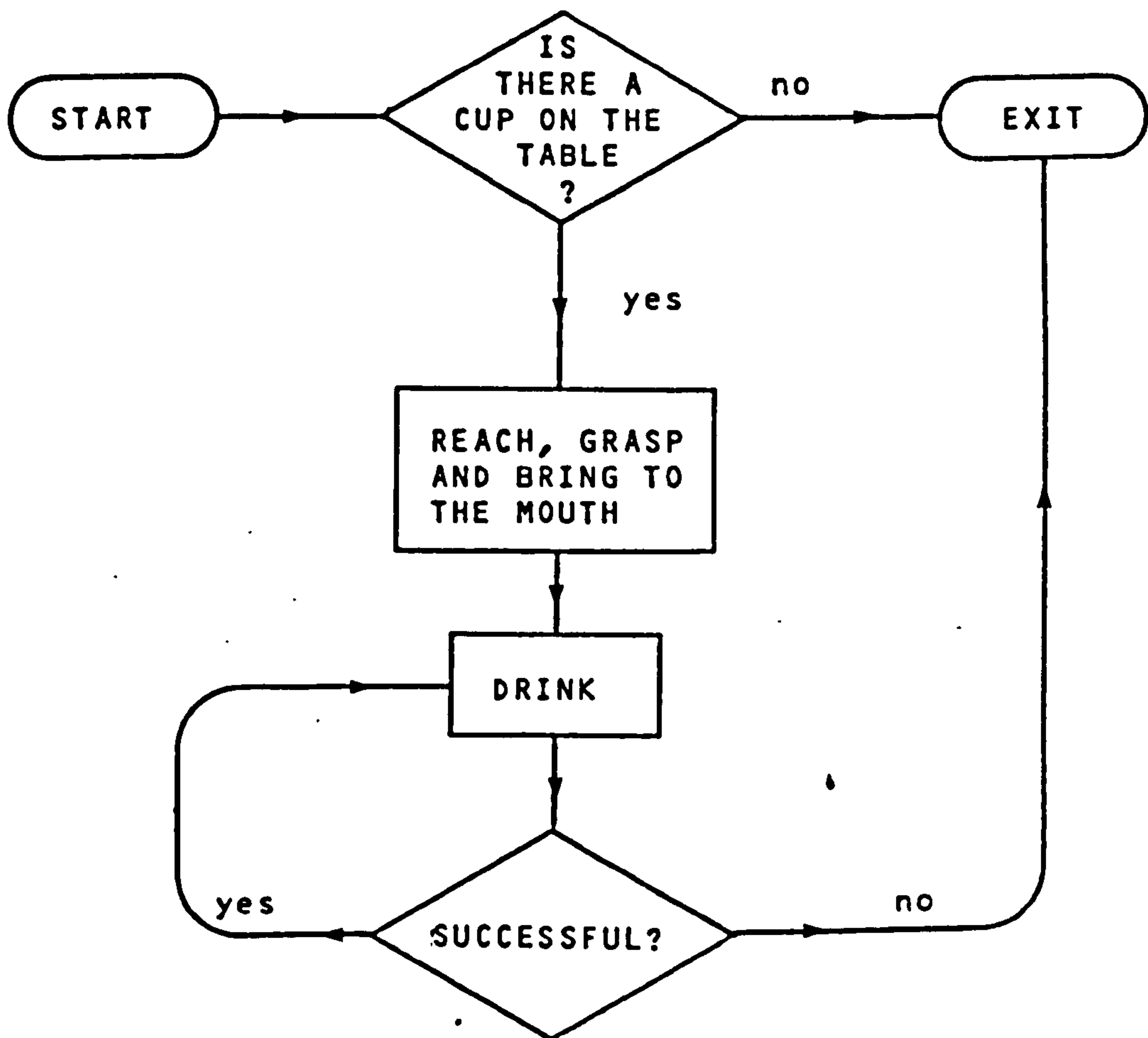

Fig 2.1 Flowchart representation of Candy's behaviour.

This rule for dealing with cups works very well and Candy has no need to change her procedure, neither has she any idea that other procedures are possible. From our point of view, though, we might say, "wouldn't it be better if she looked in the cup first to see if there is anything to drink, this would save her a lot of effort in picking up empty cups"? This entails that Candy redefines her concept of 'empty'. How might we do this?

Candy's teacher presented her with several cups, some were empty, some full of drink, and some contained lettuce leaves, pebbles, etc. After two such sessions where she was confronted with such bizzare behavior, Candy began to look inside the cups before attempting to drink from them, and has done so ever since.

In order to try and understand why this procedure produced a change in Candy's concepts, we might further speculate about what Candy does when she is trying to drink a cup full of lettuce leaves.

As she tries to drink she sees the lettuce leaves, i.e. she sees that the cup is full, but despite this her drinking procedure defines her cup as empty. She is confronted with a contradiction which she must resolve. The resolution lies in being able to discriminate between "full of drink" and "full of non drink", and this discrimination must eventually be visual. If this is the case then we must suppose that previously, when Candy drank, she was aware of seeing the contents of the cup but operated and relied on her rule governed procedure. Now when visual and procedural sets of information do not correlate she

now attends to the visual information about the contents of the cup. [Attend to visual information] is a new procedure [Look], so Candy's new procedure would be as represented in fig. 2.2.

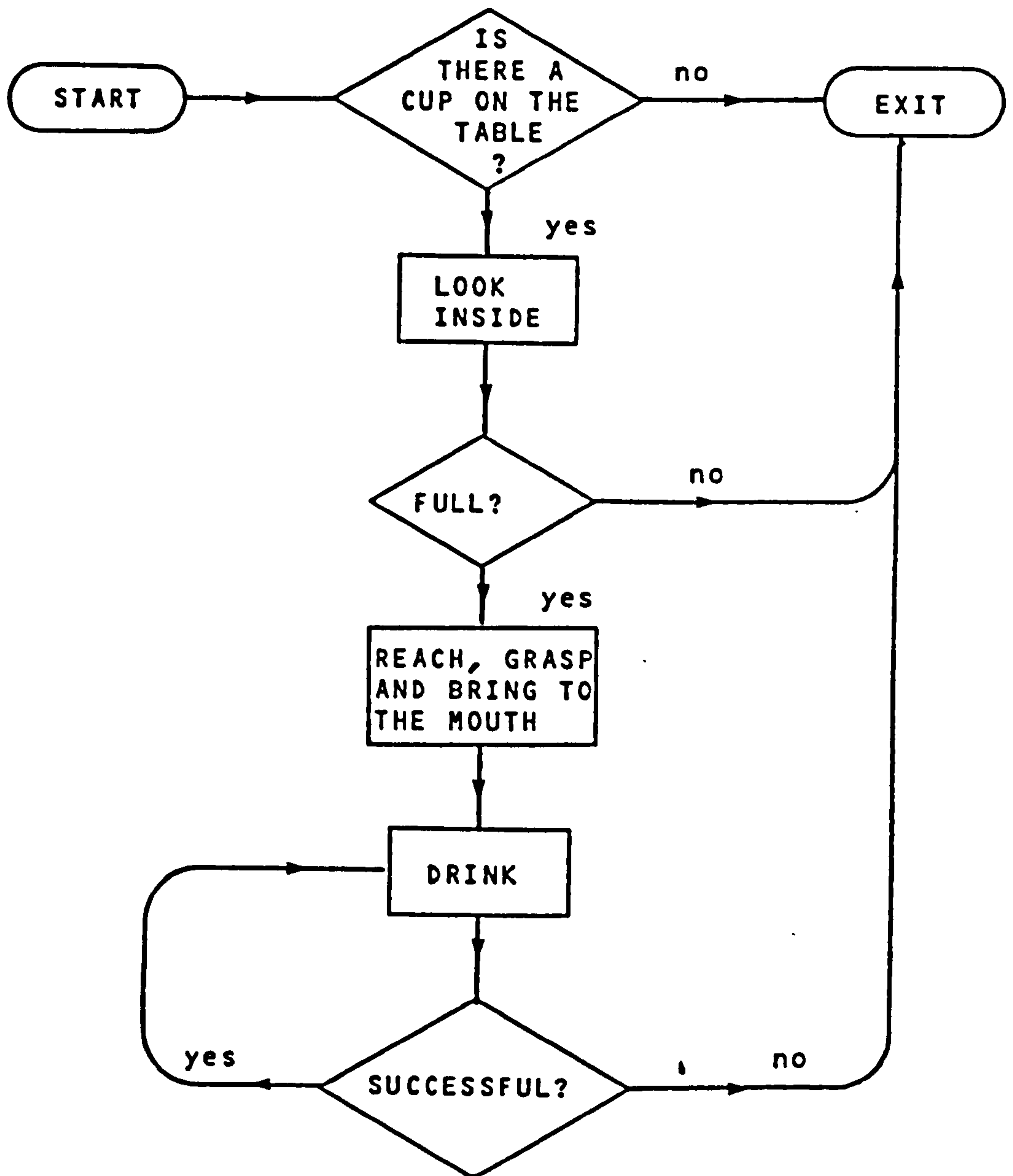

Fig 2.2 Flowchart representation of Candy's new behaviour.

Although the flowchart suggests that the procedure entails a

sequence of discrete events, in practice what Candy does is much more fluid. Looking to see if there's a cup on the table and looking to see if it's full are likely to be two acts which blend together, "reaching and grasping" is likely to coincide with "looking" etc. Despite such fluidity it must however be the case that the components of a competence are organised sequentially.

It would have been possible to use the same technique to draw Candy's attention to the visual information by, say, gluing lead weights to the base of the cup so that a (heavy = full) assumption would be invalidated.

Although it is possible to draw such flowcharts to describe our ideas about what is entailed in Candy's behaviour, we have to make a distinction between what she attends to in order to act and what she is aware of but does not use. The shifting of attention to another aspect of a situation (hitherto unused) is what Piaget termed decentration.

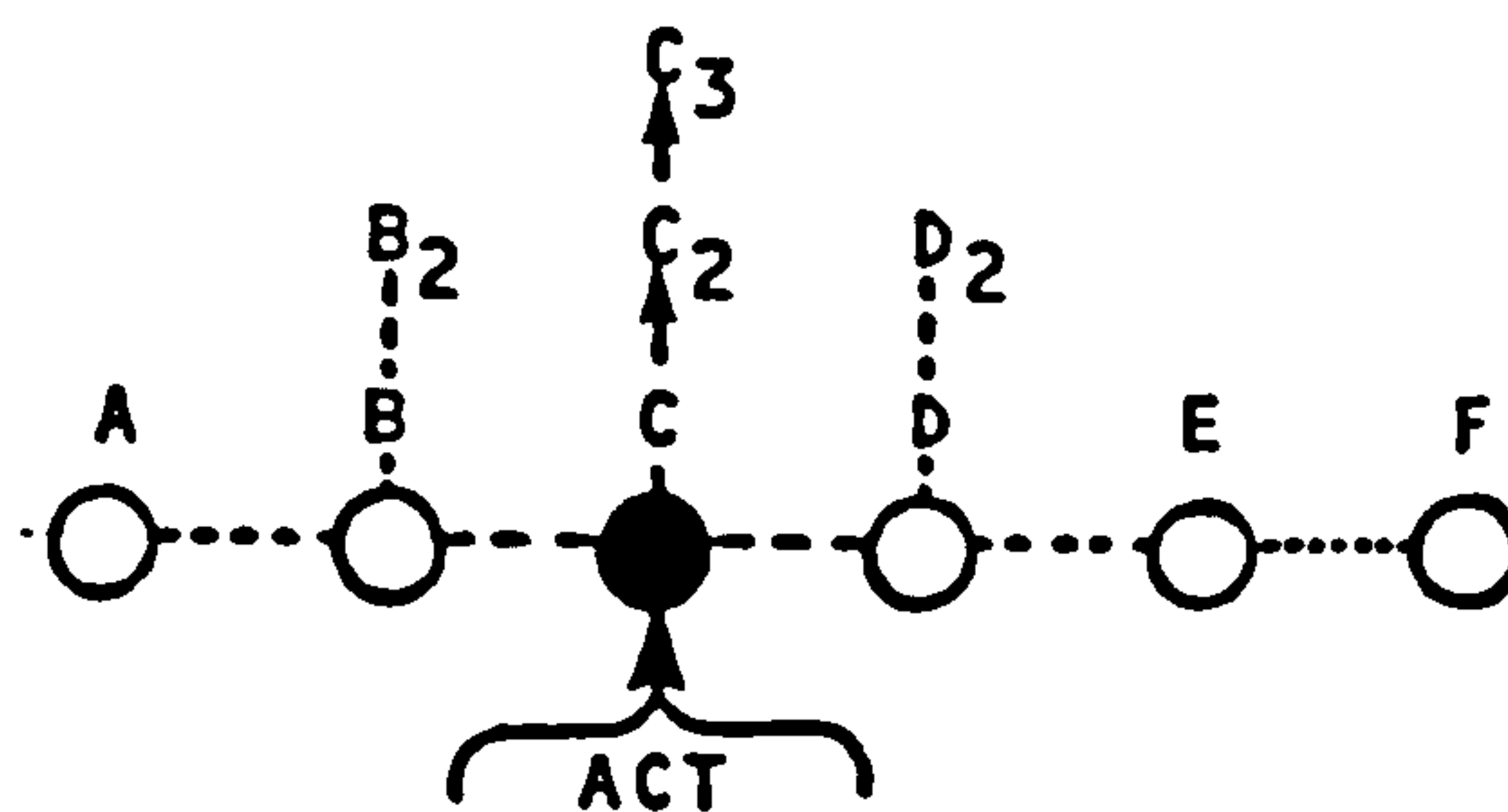

Fig 2.3 Decentration

In fig. 2.3 we have aspect "C" of a situation attended to

but where "A", "B", "D", "E", and "F" are also available. Given that "C" is attended to, some action is asserted which results in "C₂" being attended to. This same action may result in other aspects which co-occur with "C" changing, but these aspects are not used or acted upon. "C₂" may become the focus of another action which takes us onto "C₃" etc. However if the process illustrated in fig 2.3 decentres and, "D" for instance is attended to and acted upon, then this would lead to a hitherto unexplored part of the environment.

It would appear that children such as Candy and Bernie are unable to decentre, and persist in attending to elements which previous experience has led them to expect will work. Only when their ambient world is artificially manipulated, such that a particular sequence no longer operates may such children decentre.

Even so there are limitations here. Although such a technique may work with Candy for the particular situation, discussed earlier, another child may respond to the frustration with considerable agitation since alternative candidates for attention may not be readily available. How do we promote change in such cases? One method and its implications are presented shortly.

An interesting demonstration of some aspects of decentration is given by Karmiloff-Smith, Bovet, and Inhelder (1974). They asked three groups of children aged 3, 4, & 5 years respectively, to balance a set of bricks across a rectangular bar (fig 2.4).

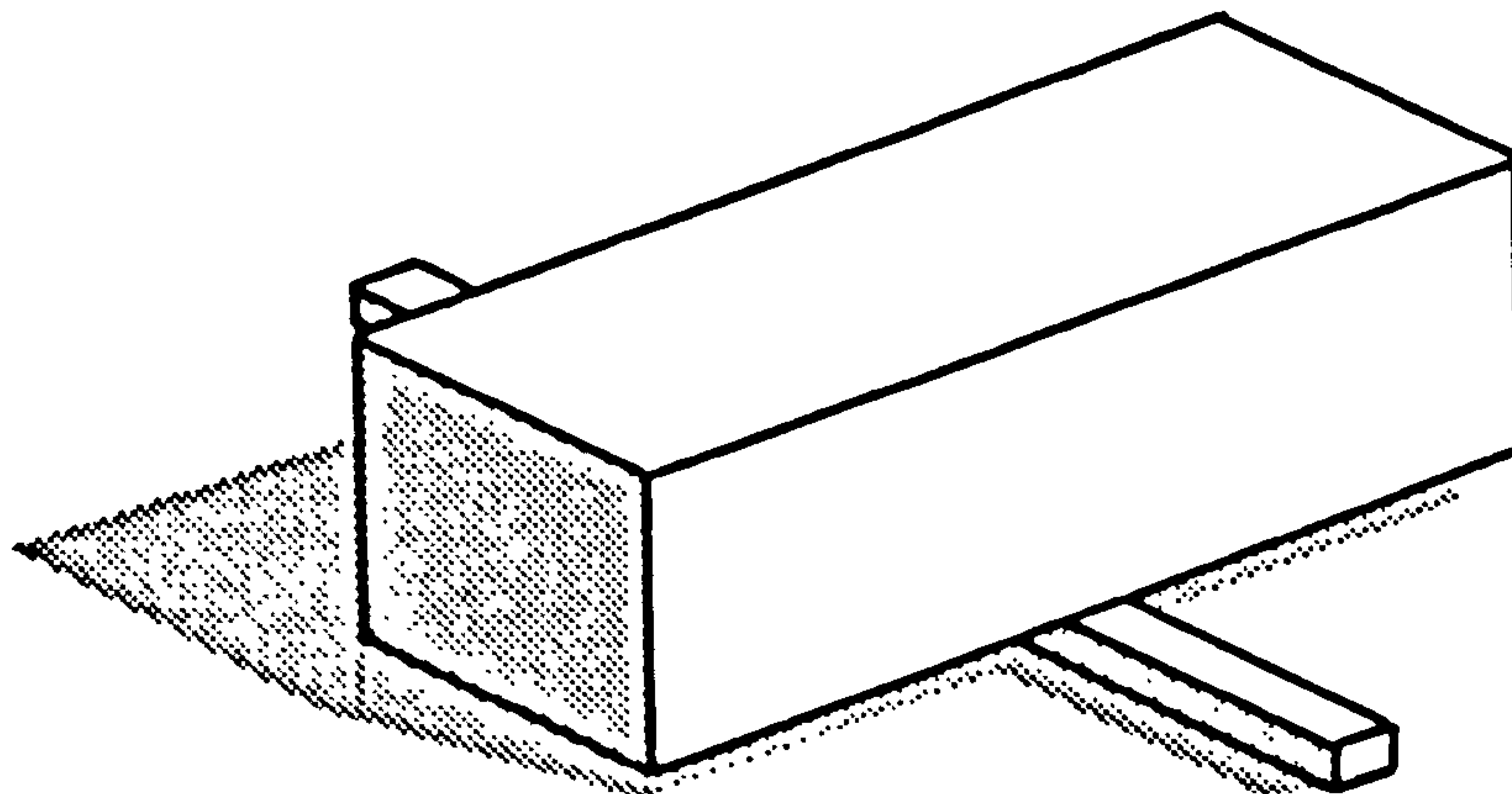

FIG 2.4 The balancing task.

The bricks were of 3 types.

- a) Simple rectangular blocks.
- b) Rectangular blocks which had a biasing weight inset at one end.(Fig. 2.5)

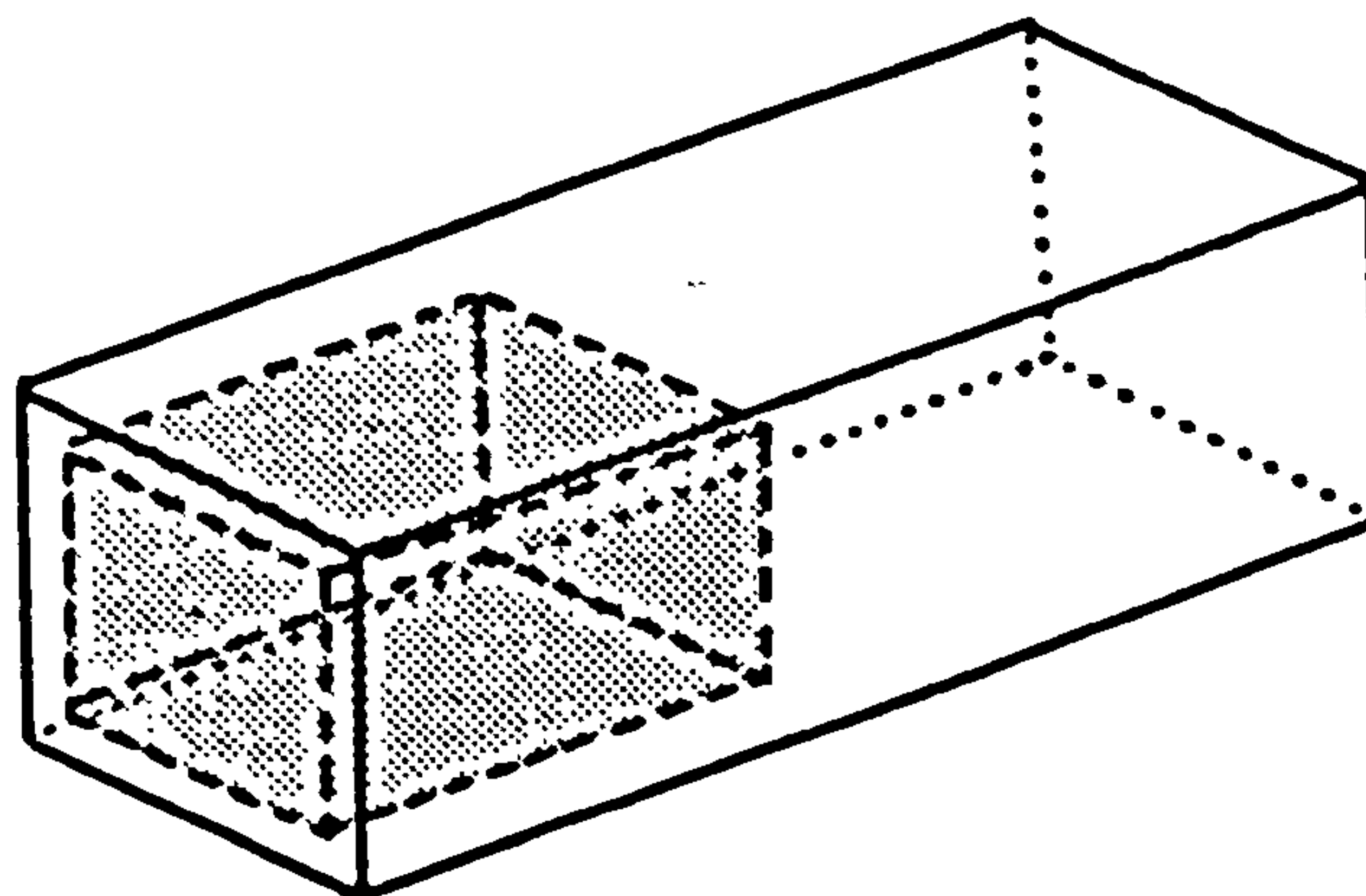

FIG 2.5 Biased block.

c) Complex blocks made of simple blocks attached together.(Fig. 2.6)

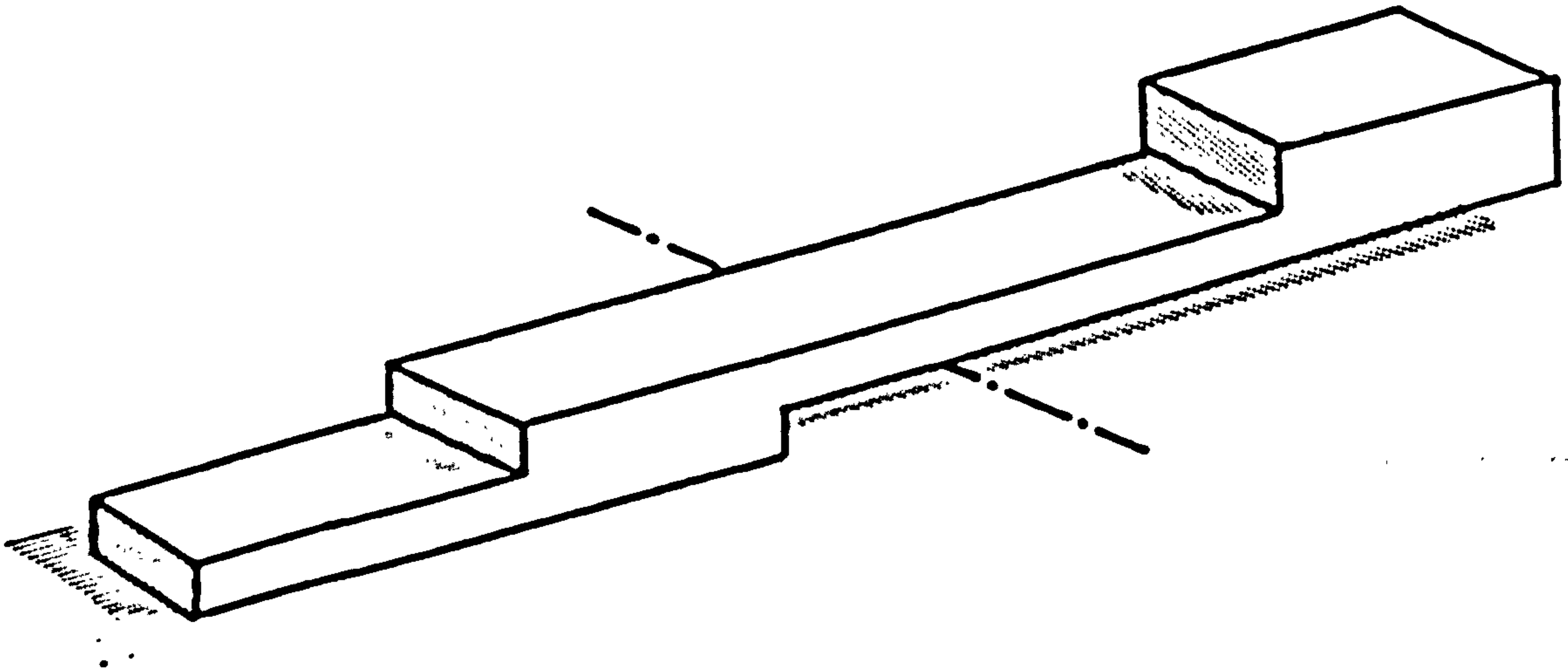

FIG 2.6 Complex Blocks.

Their findings are summarised in table 2.1

Table 2.1

Type of block	RESULT AT AGE		
	3	4	5 years
SIMPLE	passed	passed	passed
BIASED	passed	failed*	passed
COMPLEX	failed	failed	passed

*passed when blindfolded.

The three year olds operated by finding the balance point by trial and error. This strategy allowed them to succeed in balancing both simple and biased bricks but not the complex bricks.

The four year olds operated by assuming that the balance

point is the mid point of the block. This works for simple blocks but does not work for biased or complex blocks. It would appear that their adoption of a midpoint theory is detrimental to their performance on this task. If blindfolded they were forced to adopt the trial and error method of the three year olds and fared far better.

The problem of the complex blocks was solved by the 5 year olds and their solution involved using additional blocks as counterweights (fig 2.7).

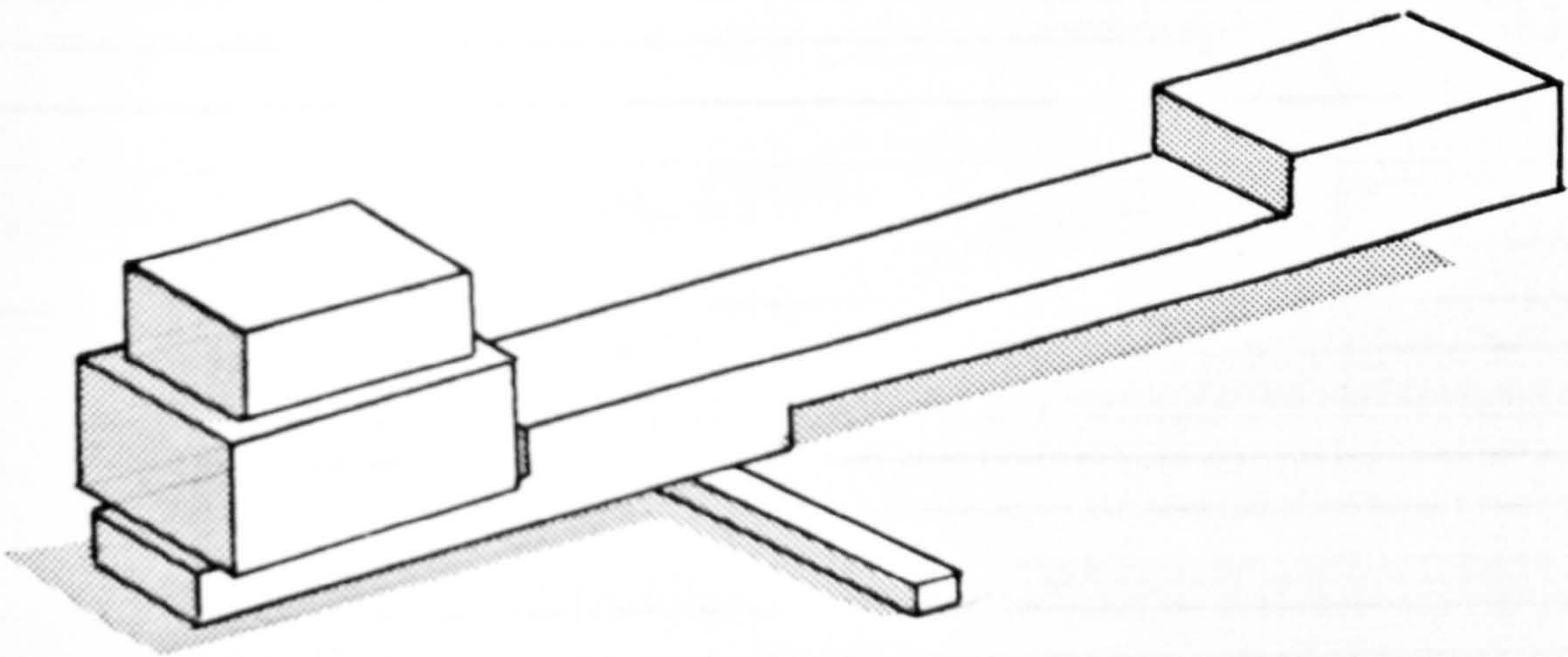

FIG 2.7 Solution to the complex blocks problem.

This type of solution entails understanding the task of balance in terms of 'moments' (BIAS X DISTANCE FROM FULCRUM). The mid-point theory of the four year olds is a necessary transitional stage between operating a sensory motor method and acquiring understanding of balance and serves to draw the child's attention to the elements that are entailed in understanding the principles of balance. However his performance

suffers in the transitional phase and in order to shift from a successful sensory motor method to a more powerful and general method of balancing bricks the child has somehow got to tolerate an apparent loss in competence for the sake of future gains.

Although this example is a contrived experiment, examples of transitional loss of competence abound in infancy. In the domain of language acquisition Bever(1970) gives the following example.

Children were asked to act out sentences such as ..

- a) The horse kisses the cow.
- b) It's the horse who kisses the cow.
- c) It's the cow the horse kisses.
- d) The cow is kissed by the horse.

Two year olds performed the appropriate actions for the first three sentences but were only sometimes correct on the fourth. They appeared to have a hypothesis that the occurrence of the sequence [noun..verb] means [actor..action] and this hypothesis leads them to attend to any instance of noun verb co-occurring in any position in the sentence. The separation of the noun from the verb by "is" in sentence (d) is something different to the two year old. The four year olds operate a hypothesis that the first noun is the actor and this leads them to attend to location. They tend to fail sentences such as (c) and (d) but are perfectly competent in (1) and (2).

T.G.R.Bower (1974) has suggested that the infant has some surprising abilities which he may lose before reacquiring at a later period. Underlying this apparent aberrance in development

seems to be a process of replacing competences based on innate mechanisms by those which are more fluid and adaptable and generated by an acquired and adaptive structure.

The infant has, a walking reflex, which is normally non functional but as Zelazo (1976) has shown, the reflex can be developed to produce some extraordinary precocious walking behaviour. However Zelazo's baby's had the mechanical gait of a toy soldier compared with the much more fluid walk of the more mature infant. It would seem that the reflexive structures underpinning this baby's performance lacked the potential for fluid accommodation to the environment. Those more adaptive processes, functioning in the motor cortex and the cerebellum, afford the older child the potential for adaptive use of feedback.

It does seem that throughout his development the infant repeatedly needs to be able to tolerate temporary loss of competence in order to make gains later. It is worth bearing in mind that though an adult can cope with short term losses in the light of longer term aims, the infant is not privy to the future course of his development, so that from his point of view a loss of competence is not short term but absolute. It is possible though that the normal infant is too preoccupied with novel competences to mourn the loss of old abilities.

In short, I would suggest that the mentally handicapped child desperately hangs onto what he can do, and cannot decenter. This theme will be expanded during the course of this work.

Guided Decentration. Earlier I suggested that decentration in the mentally handicapped might be facilitated by creating conflict between alternatives, but that only some mentally handicapped children could cope with such a confrontation. The following example gives us some ideas for an alternative approach.

A group of retarded children had been working with their teacher placing various objects in a range of different containers and retrieving them. The teacher then placed a sweet in her hand and put her hand in an open tube (fig 2.8)

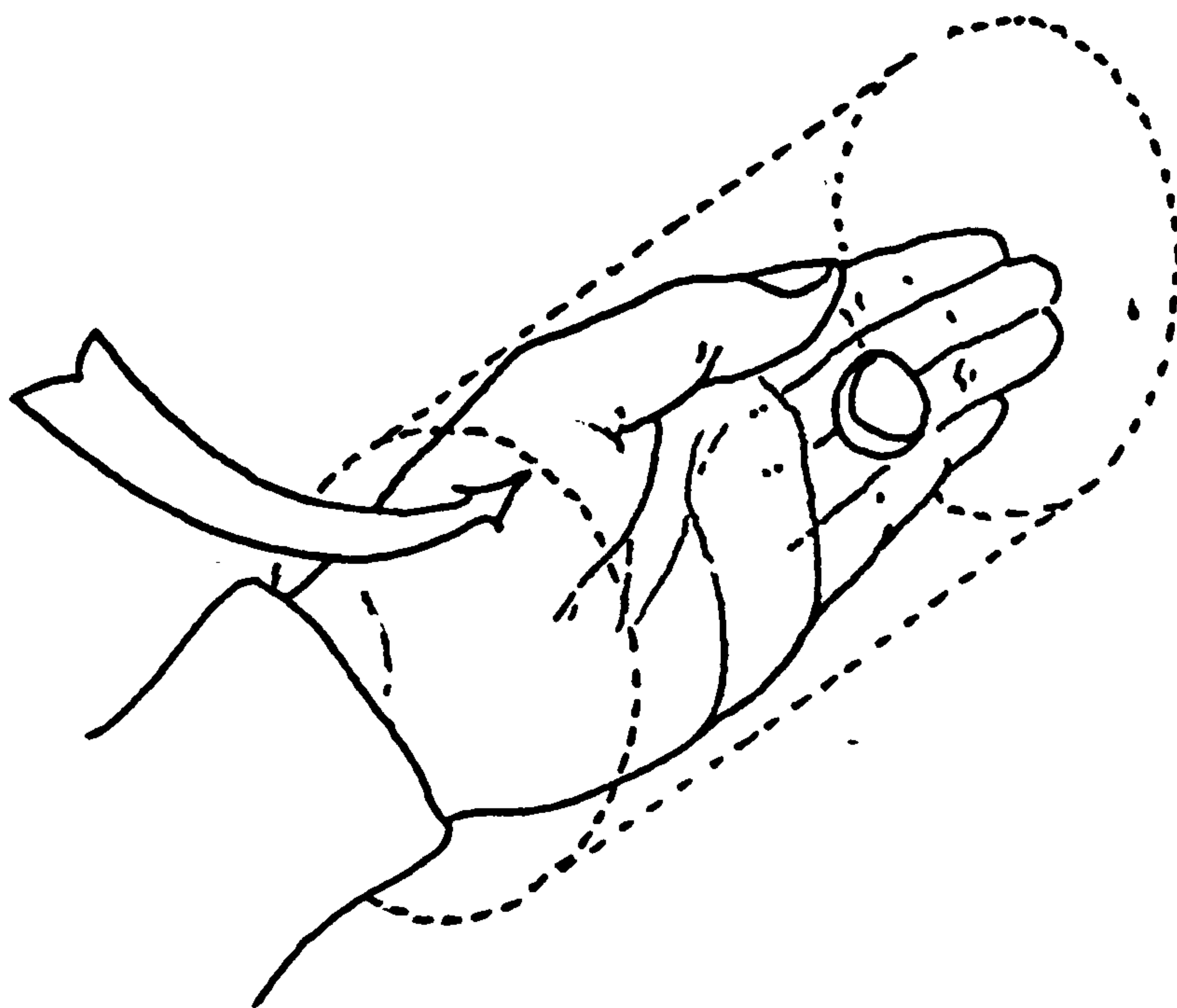

FIG 2.8 Sweet placed in tube.

All the children attempted to retrieve the sweet by trying to place their hands in the opening obstructed by the teachers arm and ignored the unobstructed other opening. They appeared to be operating a rule learnt from the other containers.

[TO RETRIEVE AN OBJECT FROM A CONTAINER REVERSE THE

PROCEDURE THAT GOT IT THERE IN THE FIRST PLACE]

Consequently they ignored the open end of the tube. Although this example has parallels with the 'lettuce leaves in cups' example presented earlier (inasmuch as the child is confronted with a situation where a normally successful procedure fails) it does not seem that the children have available alternative features to attend to here.

The non-availability of the "open at both ends" feature of the tube may reflect that either this feature does not exist in the child's repertoire of possibilities, or alternatively that just too much effort is involved in bringing the feature into the centre of attention.

Following their failure to solve the problem, the group was led by the teacher into what might be termed a guided play session.

In this session the children were helped to explore the properties of the tube by activities such as looking at each other through the tube, touching each other's hands through it etc. The original sweet retrieval problem was presented again and all the children succeeded in obtaining the sweet by reaching through the open end of the tube.

In the guided play session the aim of the activity was to draw the children's attention to the "two opening" aspect of the tube. Other aspects of the tube could be entertained: rollability, acoustic properties when shouted through, etc. While these properties were incidental to the original problem they

might provide solutions to other problems.

The teacher, in drawing the group's attention to the open end of the tube had the advantage of knowing the solution before hand. Had the group been able to play they would not have the advantage of this foresight, but in the process of playing would acquire knowledge of many of the properties of cardboard tubes, one of which would provide a solution to the problem.

Fagan (1973) has defined play as "information gathering in a relaxed field". Bruner (1973) has similarly commented that in play the infant is buffered from the consequences of his own actions. Both these authors imply that the playing child is in a state where the need to succeed is suspended and it would seem that whatever "force" holds a child to a particular hypothesis or feature is relaxed so that he is free to decentre and is then in a position to generate new hypothesis or procedures.

In attempting to understand any person's condition it is often a useful exercise to realise that oneself may be operating under similar conditions, and the inspection of one's own processes may help one to understand the other.

Consider the following hypothetical situation. Tomorrow I have a job interview. On paper I am a reasonably competent candidate but subjectively I may feel either confident or anxious. I am preoccupied with thoughts about the event. I entertain images about the interview. In my mind's eye, I see myself in the interview room, I anticipate various questions and

see myself providing answers. Sometimes my anticipations are realistic and it could be said that I was planning. Other times my imagined behaviour is more divorced from reality and I would be said to be fantasising. The "reality" referred to is in the future and it is inferred rather than known since I am not omniscient. In my imagining, my thoughts may lead me to realise that there are gaps in my competence which may be exposed in the interview. This may lead me to read, to ask questions of others, to gather information and enrich my understanding.

When tomorrow comes, some questions might have been anticipated but most are novel. As long as I am not overanxious I am in a position where I can formulate appropriate responses by virtue of my previous work in putting a great deal of information in a readily available form.

If I am overanxious, despite my preparation, even though the information for the appropriate answers exists somewhere inside my head I am unable to access it and my performance comes over as stammered monosyllabic responses.

If I have done no preparation for the interview I may, when faced with questions, become an anxious and incoherent person. However, if my attitude towards the interview is "it's not really important but I'll try". I may be relaxed enough to recall and utilise available information effectively and give quite a good account of myself.

In these variations on the interview theme the sheer

complexity of the information dealt with is of a different order from that dealt with by Candy in the problems that she encounters but our attention can be drawn to similar issues involving the acquisition and structuring of competence and the role of anxiety, risk taking, etc. in the preparational process.

Were we able to understand these issues we might be in a position where we could help "retarded" children to play and so alter the style of their relationship with the world.

For the greater part of this work I shall be attempting to develop an understanding of what makes play possible in normal infants and why mentally handicapped children do not play. I shall, in so doing, further explore the assumption that play is necessary for development.

In approaching a problem the investigator has a wide choice of approaches and his adopted approach reflects his own style, the nature of the problem, availability of technology, etc. The account and analysis of Candy's behaviour is a mini version of the overall approach adopted in this work. A specific situation was described and an attempt made to understand what was happening by building a flow diagram. If the diagram is inspected critically and carefully it will soon become apparent that in drawing it I have made some assumptions which I have no direct evidence to support. It is also true that I have presented no evidence which contradicts my assumptions. This may be a case of selective blindness, but for the moment I am fairly happy about my assumptions. My attempt at understanding the situation

involves my making some guesses and these are partially legitimised by their contribution to the overall understanding of that which predicts and promotes therapeutic change. The overall explanation has a logical structure which the flow-diagram attempts to express explicitly.

In the same way as the logic of my attempt at understanding Candy's behaviour can be thus represented, so can the logic of my attempts to answer the broader questions about play in the mentally handicapped be represented. However the nature of explanations about play, risk taking etc. are likely to be complex and the task of examining the logic of such an explanation becomes difficult.

CHAPTER 3 ...More of cups and Lettuce Leaves

Let's summarise our understanding of the material presented so far and from this raise some questions which may help to extend our understanding.

We have posited that in being presented with a problem;

- 1)The child attends to certain attributes of the situation
- 2)Somehow connected with these attributes are procedures which he can operate to produce results.
- 3)The child has other attributes potentially available.
- 4)These attributes also potentially have procedures somehow connected with them.
- 5)The child needs to acquire new attributes and by implication may need to build new procedures.
- 6)Phenomena such as anxiety, perception of success etc. have a role to play in these processes.

We can begin to tidy up these notions by thinking of the procedures as coherent units of organisation which are made available by attending to the relevant attribute. Furthermore, at a given moment in time the child has some constraints about how many units he can attend to.

So far we have only mentioned situations where the child attends to one attribute which serves to make other associated attributes available for attention, but later we will need to look at situations where attention involves greater complexity.

We can schematically represent these ideas as in fig 3.1.

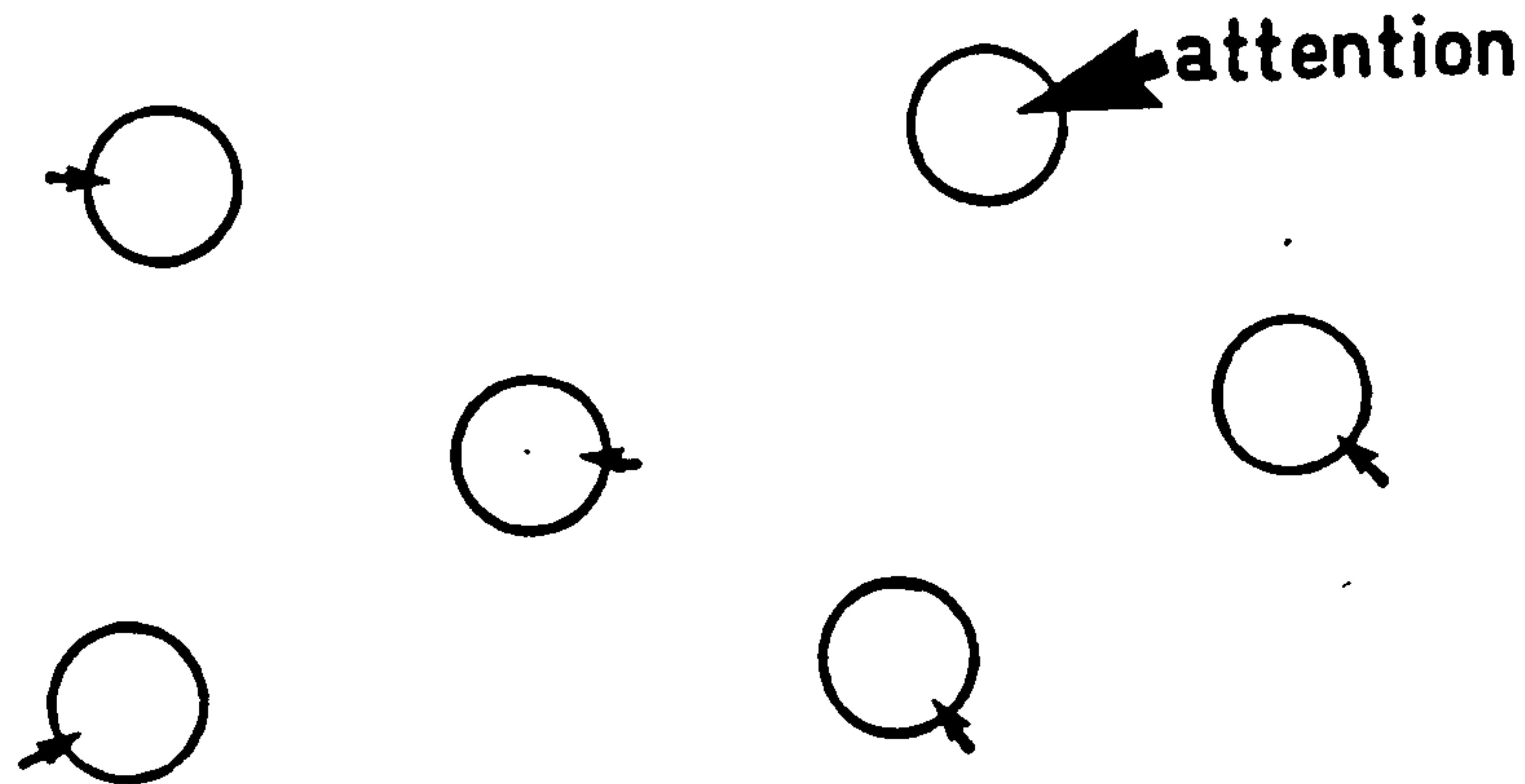

Fig.3.1 Initial status of model.

At this point three questions are raised which, if we can answer them will give our model greater definition.

- a) What is the nature of these units of organisation?
- b) Is there any relationship between these units of organisation?
- c) On what basis does the child chose to attend to a specific unit of organisation?

Although any answers must in the end be interrelated we will begin by positing some partial solutions, taking each question independently.

Nature of the units of organisation.

Let's speculate about how a toddler operates procedures serving to define his conception of a dog. Somewhere in his mind's eye there may be a set of images of dogs that he has known in specific situations. When confronted with a particular

instance of dog he will attend to specific "doggy"* attributes, some of which items are behaviours "generated" by the dog which may imply specific behaviours on the part of the child. So the dog is represented both as an object and as a source of actions. Furthermore there may be actions which the child initiates which the dog responds to in a specific manner. Such behaviours on the child's part might be termed "tests" and would be part of his representation of the dog. We could represent the child's relationship with the dog as a "dog" check list.

```

wags it's tail.....pat it
has fur
growls.....keep clear
offer it food.....eats it
has four legs
licks.....urgh
has ears.....pull them
gives you piggyback rides
call it DOGGY
throw stick.....fetches it

```

In practice such a check list might operate by calling up the individual items in sequence, attending to each item in turn. However the sequential order may vary and also items on the list may reoccur. Constraints may operate which make a particular succession of events unlikely. e.g. It is not likely that the dog will lick immediately after it has growled. If we are to take temporal sequences into account it may be more convenient to represent the child's relationship with the dog as a network of events, as shown in fig.3.2. Recording the sequence of items

* (This conception of a category as a set of attributes originates with Rosch (1973) and aspects of the child's development of semantics are modelled in a similar manner by E. V. Clark (1974). Smith, Shoban, and Rips (1974) employ a similar featural model. They make a distinction between 'defining' and 'characteristic' features and their model is similar to the the present model as it is extended in chapter 4.)

which are encountered in the course of moving within the network would generate a list which would represent both attributes and their temporal relationships.

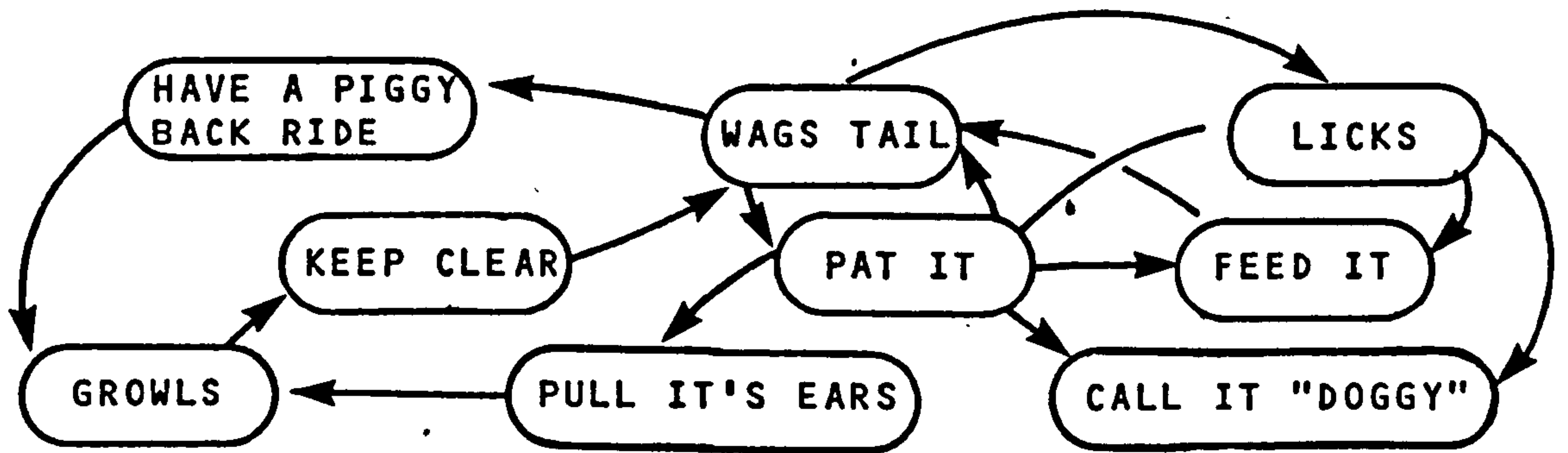

Fig 3.2 Representation of Dog as a network of acts and events.

In Candy's case we had a similar but far simpler situation, the sequence of drinking action was initiated or accessed by the mere presence of a cup. Once "called up" her particular drinking procedure would operate in an automaton-like manner.

Our doggy network is less simple to operate. The conglomeration of dog procedures might be called up by the mere presence of a dog, but this presupposes that the child discriminates between, say, dogs, rabbits, and cows. Having called up the doggy procedures, our theoretical toddler still has the problem of deciding where in his tangle of procedures he starts off, and furthermore which particular sequence he operates. Apropos the latter decision, it would seem that some pathways in the network are, as it were, better trodden than others, but the child would still need to be flexible in his choice of pathway otherwise his behaviour would have the rigid

and rather obsessional quality that children such as Bernie manifest.

As previously suggested, the pathway taken through the network during a particular confrontation with a dog can be represented by a list if the ordering of the items in the list corresponds to the sequence traversed in the network. The reoccurrence of an event simply entails that that item is entered more than once in the list.

Some support to this "list model" is given by the following demonstration. A hiding game is played with a child who has recently acquired the concept of an object's existence independent of his actions. The attainment of the concept is tested by the following procedure.

Three small screens are set up side by side on a table. An object in which the child is interested, such as a sweet or small toy, is covered by a cup. The cup is slowly passed behind the three screens in turn, care being taken that the child follows the passage of the cup. In passing the first screen the object is left behind. The child is now required to find the object. (The procedure so far is actually a replication of the last item of the Uzgiris and Hunt object permanence scale which is described in appendix 1)

A child who has fully attained object permanence will typically look behind the last screen that the cup passed behind. On failing to find it there, he will then work systematically backwards until he finds the object behind the first screen.

The problem is now repeated but this time the experimenter employs sleight of hand, concealing the object in his hand. The child will search systematically as before and will be somewhat perplexed when he fails to find the object behind any of the screens. The experimenter then retrieves the object from behind the child's ear!

The problem is again set up and the experimenter again conceals the object in his hand. On this occasion the child will typically begin his search by looking first behind his ear before proceeding to look behind the three screens. When the child fails to find the object this time, the experimenter retrieves the object from under the child's sweater. On a subsequent presentation of the problem, the child first looks under his sweater, then behind his ear, and then behind each screen in turn...and so on.

It would seem that the child here is operating a list of hypotheses, the list being extended by adding to the top of the list the most recently acquired hypothesis* and that the list is entered by the most recently occurring event. Yet in real life the most recently occurring event is not necessarily the most salient. We could visualise a child engaged in this hiding game wanting the object to be found behind her ear rather than under her sweater because the experimenter tickles when he retrieves it.

* Note that we cannot use this technique to support our notion that items may occur more than once in the list.

Thus the point of access into the network varies as different items turn up at the top of the list. So, according to the "list model" every time a dog enters the child's life he will attend to whatever attribute his last encounter left on top of the list. We can envisage that given some experience of dogs some specific attribute will dominate the list.

If we look at the original "dog list" given on page 38 we will find that one attribute of dog is the name "doggy", which the child can utter in its presence. This is not to say that the child uses the word to symbolise a dog's image, the utterance is merely one of many means that the child has of relating to the animal and has no different status from, say, pulling the dog's ears. However any attribute which serves to address the dog network will by virtue of its addressing role have a different status from the others. Piaget (1951) termed such addressing attributes, "indicators". It would seem that in a social context the child soon finds that employing attributes which happen to be utterances as indicators is particularly useful. So he begins to use utterances to address things. This has the very important implication that another person can easily provide the addressing feature. By merely writing the word cow, I can conjure up an appropriate image in my readers mind. I can extend the image by writing "the cow jumped over the moon". This may conjure the image of a cow with N.A.S.A. stencilled on its flanks, or it may bring back memories of a favorite book not seen for many years.

*Detailed explanations about how this might be done will be provided later.

At this sort of level the use of language becomes very complex but it allows hitherto private cognitions to become social and shared.

The indicator seems to be a phenomenon manifest in the transition from prelinguistic to linguistic means of handling images but in adult language use a similar phenomenon appears in the form of metonymy whereby a thing is referred to by the name of a particular part. e.g. Crown standing for King.

Consider the following example. A sailor in the crows nest will "spy a sail". What he perceives is a ship but in this context "sail" is a particularly relevant part or feature. The same sailor would never refer to the same ship in port as a sail. In that context he would term it a vessel, and thus highlight the ships capacity to contain goods. {The example is derived from Lacan.(1977) {Humphreys (personal communication)}

Although it does not necessarily follow that language is purely metonymic the structural similarity between Candy's use of a cup and the linguistic device is intriguing, and suggests that similar partial structures underlie sensory motor and symbolic structures.

Levels of structure.

So far we have considered bundles of organised information and have examined how these bundles might be accessed in a particular context. Let's now examine further how these bundles might be organised.

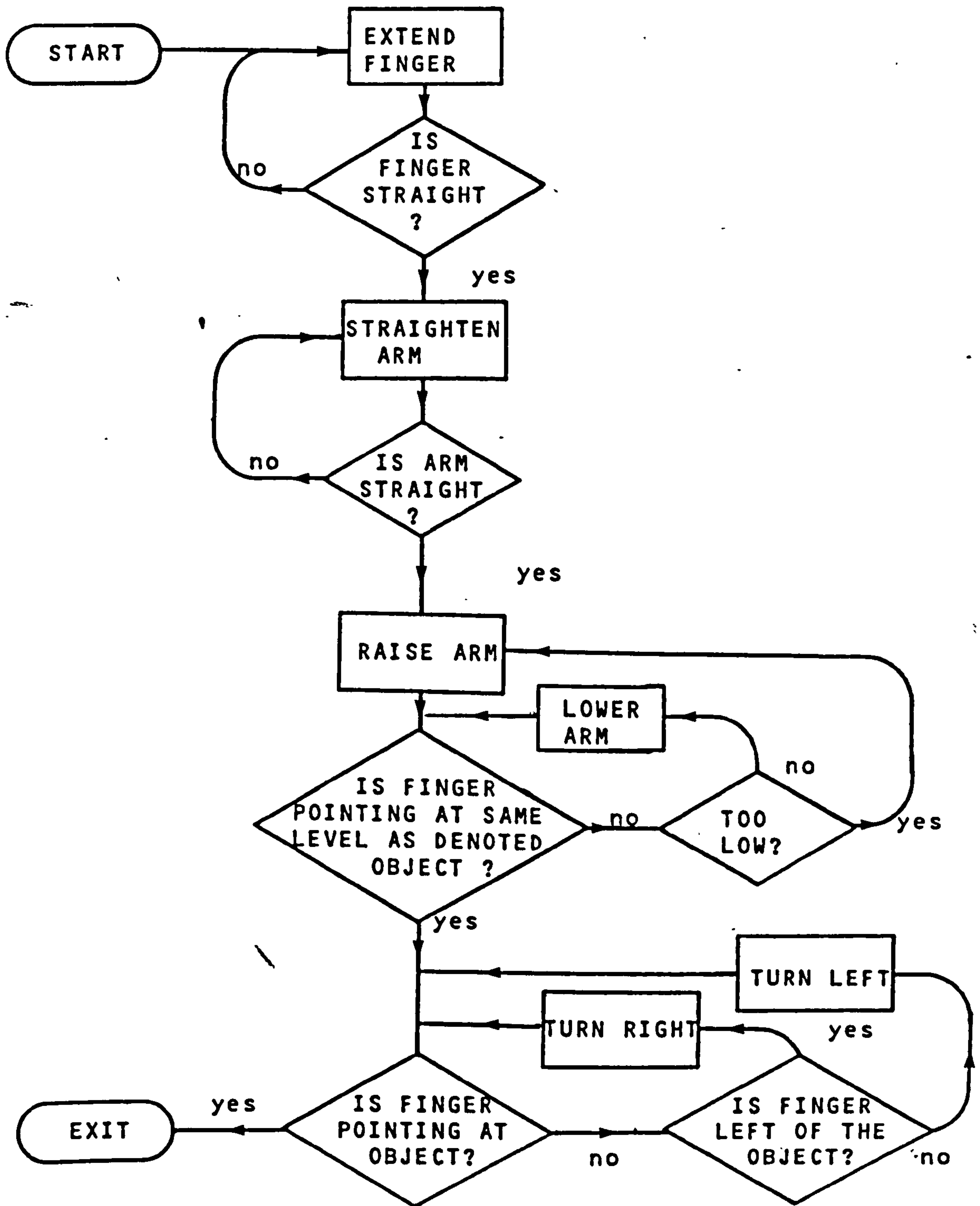

Fig 3.3 Subroutine: Point at object

If we consider our dog list again and take any item on the list it becomes apparent that each item has a similar structure to the overall bundle of which it is a part. Take the following incident. Our hypothetical toddler is confronted by a dog. The dog wags its tail and the child gives it a biscuit. While the dog is eating the child points at it at the same time uttering "doggy", he then pats it, pulls its ears, etc.

We can represent this as a specific procedure made up of subprocedures. Sometimes two or more subprocedures may occur together. e.g point and say "doggy". The act of pointing could be described as a procedure as shown in fig 3.3.

If we followed this procedure to point, our movements would be stiff and mechanical. Even an uncoordinated toddler would have more grace of movement than our procedure, since he has far more sophisticated feedback systems and also because components in his procedures would appear to overlap.

We could change our perspective further and consider a subunit of our pointing procedure, [is arm straight?] for instance, and attempt to write further subprocedures for this item involving the behaviour of individual muscles. This would entail monitoring kinaesthetic information and possibly visual information. Following this we might be able to write procedures for even lower levels.

By now the reader might have forgotten that I'm describing a child playing with a dog. In dealing with so much information it

is very easy to lose sight of the whole. Our toddler might have the same problem were he consciously working out the relationship between his biceps and triceps and he might sympathise with the mythical centipede who one day discovered he had a hundred legs and never walked again.

In practice our lower units of organisation may be adaptable and involve many decisions, but they are unconscious in that they are operated without being attended to. We shall use the term schema for those units which could be defined as "enduring organised representations of prior experiences" { Neisser(1967), Bartlett(1932), Piaget(1950)}.

We can now update the state of affairs depicted in fig 3.1 using the representation given in fig 3.4

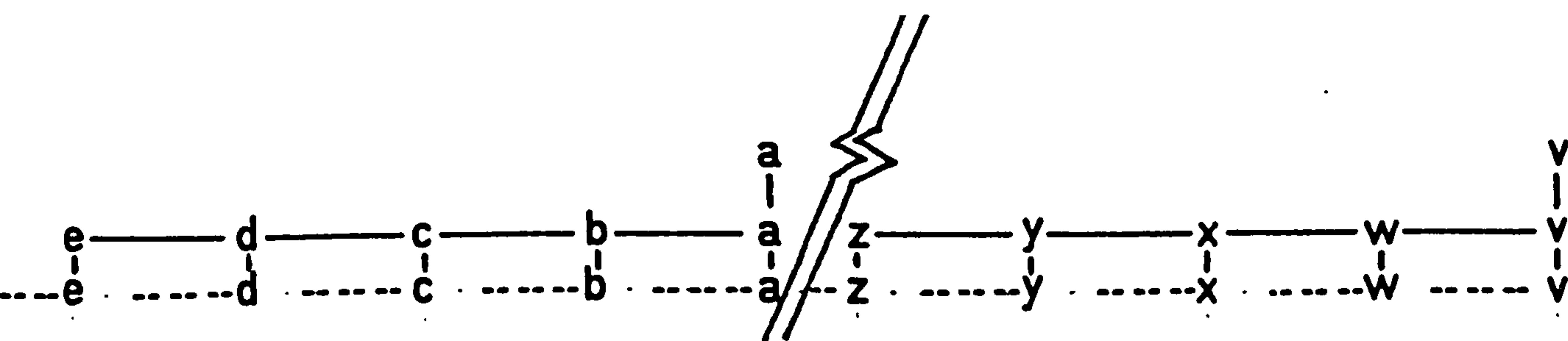

Fig 3.4 Metonymic coding of embedded Lists.

Here we have lists of lists, where the items on the list represents either things to attend to or things to do, and furthermore the relationship between each level of list is metonymic.

Flow of control.

When discussing Candy we implied that whilst she operated her [test by drinking] procedure, visual information was available to her but not utilised. We could rather crudely label parts of fig 3.4 to represent this as in fig 3.5.

Although as yet this type of representation does not cope with the type of process that flowcharts such as figs.2.1 & 2.2 represent, we can partially represent the transformation from fig.2.1 to fig.2.2 by a reordering of the list in fig 3.5., such that [look at contents] precedes the [pick up and drink] procedure.

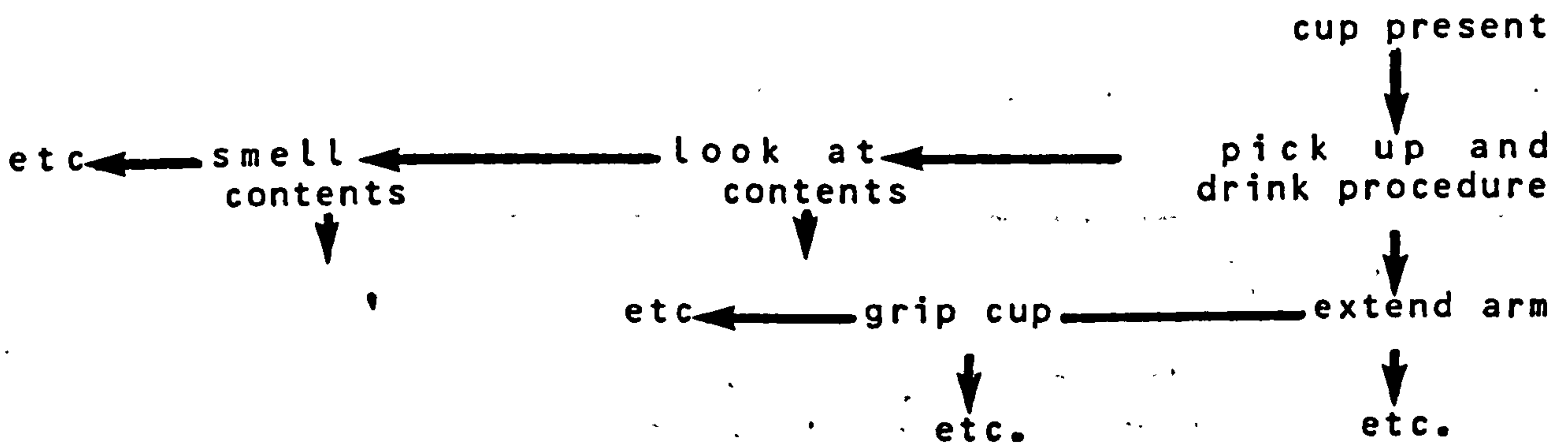

Fig 3.5 "Pick up cup" procedure as nested lists.

We could further envisage Candy deciding on the basis of smell rather than taste whether to drink the contents of the cup or not. The situation could now be represented as in fig 3.6

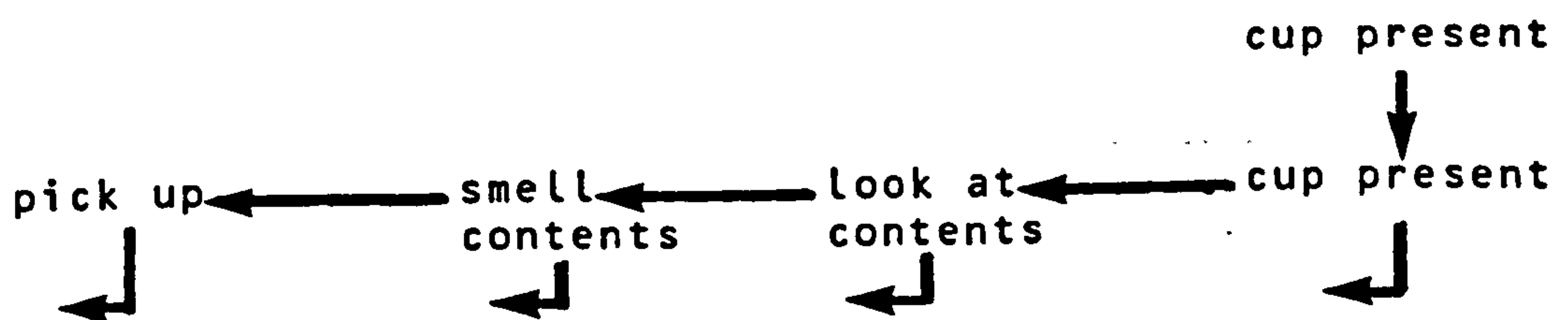
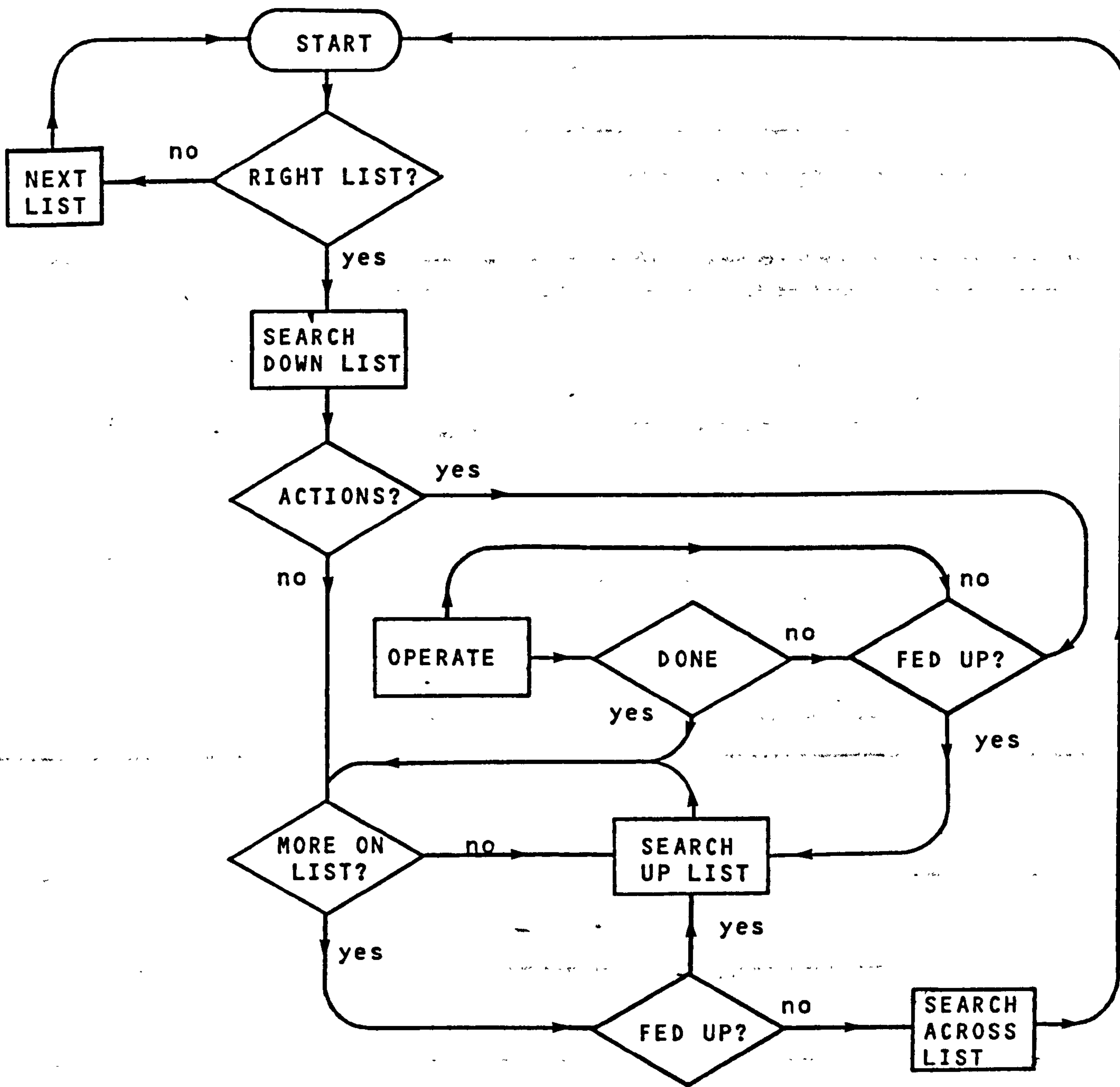

Fig 3.6 "Pick up cup" : Modification of procedure.

In a flow diagram we can represent decisions by a question set in a lozenge "<>" whereby a specific condition is tested. e.g. <is cup full?>. It would seem that we can utilise a similar notion in our embedded lists. We would enter the list structure shown in fig 3.6 by noting if a cup was present or not. If not present we would move onto another list structure. If the cup was present we would then call up the [look in the cup] list. Having established it was full we could, if we wished, continue to visually inspect the cup for the drinkability of its contents. This might entail searching down a list of possible alternatives..

```
looks like beef      ...move to next list
looks like tomato...move to next list
looks like fish...exit to another list.
      :
      etc.
```

In this case we move down the list and consider each item in turn until we find an item in our list where conditions are satisfied. We then follow the instructions attached to those conditions. (We are making the convenient assumption that each list contains all possible contingencies). As long as a "non drinkable" condition is not encountered, in which case the "pick up cup" procedure is abandoned, the list will provide instructions for moving onto the next list, i.e. the 'olfactory' list, to further establish drinkability. Within this list we might have the following items.....



COMMENTS:

<RIGHT LIST>Does this addressing item have any correspondence to what is sensed? e.g. "Is a cup present?"

<FED UP>In order to avoid the system having to continue acting in the face of no success some means of escape is necessary.

Fig 3.7(a) General rules for List searching.

smells of beef...move to pick up list
 smells of tomato...move to pick up list
 smells of fish...exit to another list.
 :
 etc.

The same procedure would be followed until the cup's contents are deemed "drinkable" or not.

Where we had cups filled with lettuce leaves we seem to have a slightly different list searching sequence induced by surprise. We might therefore suggest that contradictory conditions will cause a shifting of attention up and along a list level so that the next list is attended to.

Our model now consists of lists embedded in other lists and some rules for moving through the lists. We can attempt a comprehensive representation of our rules as shown in figs. 3.7a & 3.7b

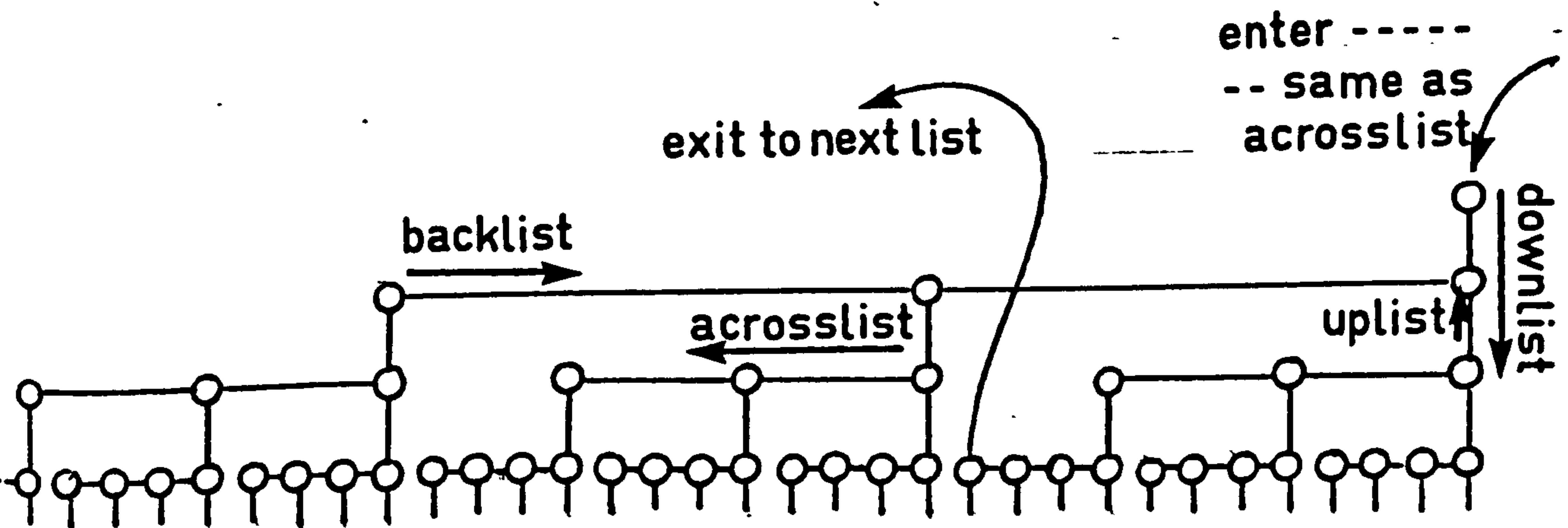

Fig 3.7b Directions of list searches.

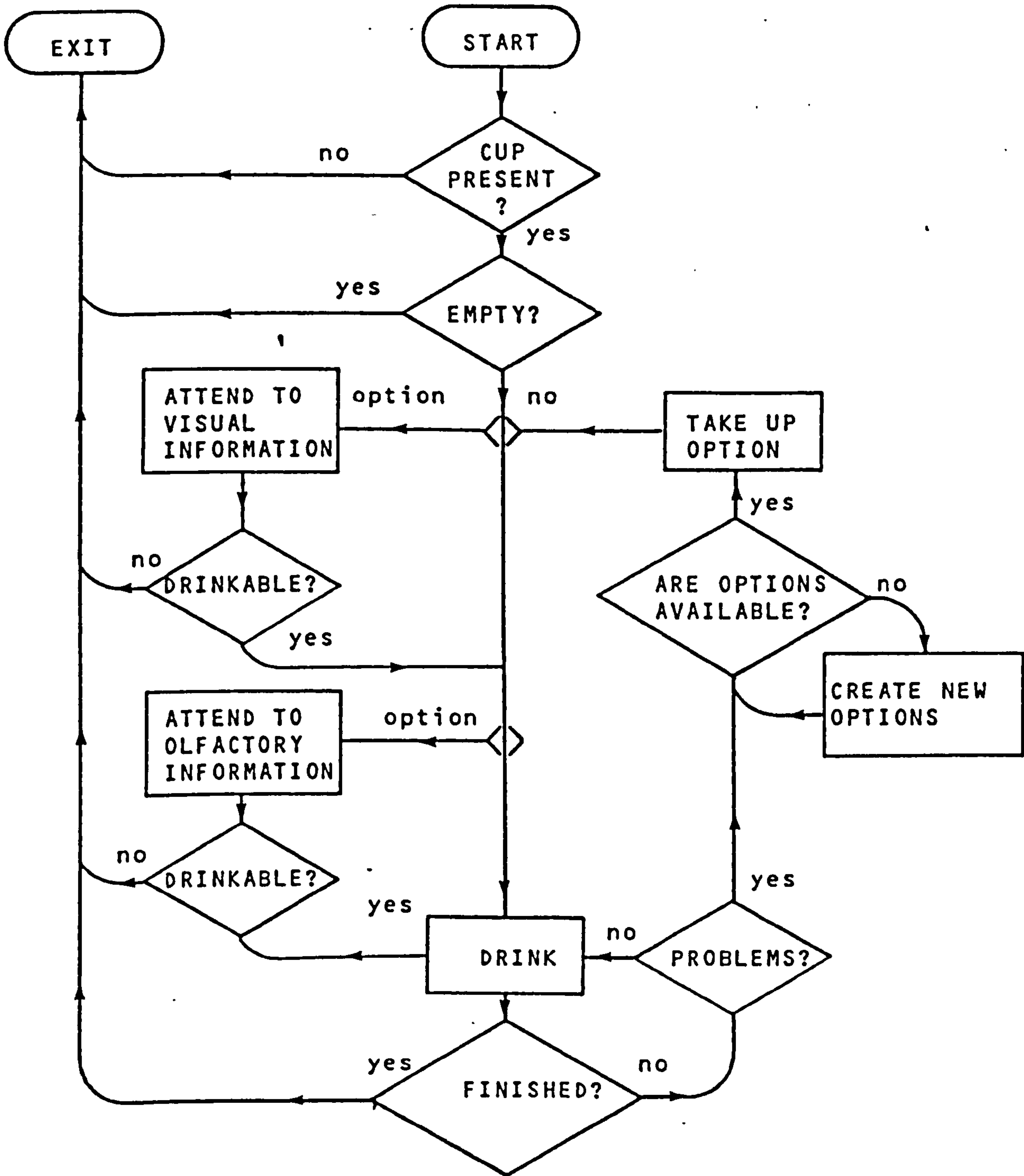

Fig 3.8 Updated "DRINK" procedure

We can update part of our flowchart in figs. 2.1 and 2.2

to give us the flowchart shown in fig 3.8

This works reasonably well but it leaves many questions unanswered, especially questions like "where do new options come from?"; "How might options be attended to in the absence of a problem?"; "What is meant by <problem?> in the flowchart?".

In our deliberations on lettuce leaves in cups and images of dogs we formulated the notion that the child seems to hold information as embedded lists. We also partially described the lettuce leaf problem as set of rules for moving through these list structures. We made these rules more formal by describing them as a flow diagram (Fig 3.7a).

So far we have a general purpose structure and a set of general purpose rules for moving through our list. Yet these rules take us not much further than the situation described in fig 3.7. Let's see how well the model works with Candy by looking at how fig 3.7 applies to fig 3.6.

The child is confronted with a cup, by moving around the loop...[right list? yes;down list; action? no;more on list? yes; across list; right list? yes; down listetc.]..the system runs through a checklist of cup attributes until it's satisfied that a cup is present. Having decided that he has enough attributes to define a cup < enough?>, he moves up and across the list to the list system labelled [look in cup] The search now procedes...[downlist{to access the components of [look in cup]} ; action? yes {i.e..looks}; operates; done? yes; more on list? yes;

fedup? no; across list {i.e. brown fluid}; right list? yes; down list; action? no;.....etc]....and thus attends to the range of attributes that describe the contents of the cup. Assuming all is well the lists will be followed in this manner until the cup is drunk out of.

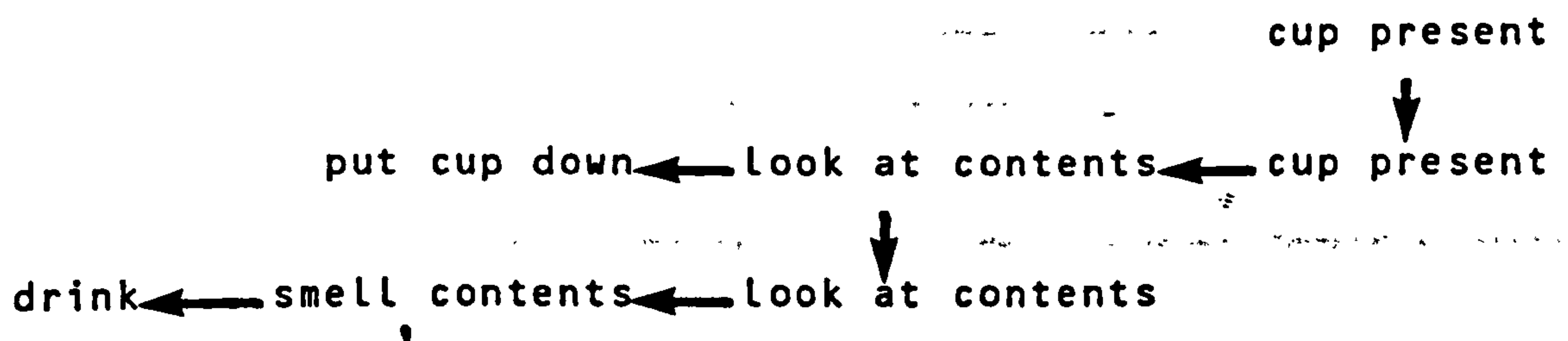

Fig. 3.9 Updated list form of [DRINK] procedure

If any 'non drinkable' attributes are discovered, somehow the child must get out of the list. It is tempting to insert an item into our flowcharts along the lines of <if attributes have negative qualities exit from the list>. Behaviourally this would result in the child simply dropping the cup. Although in reality that is possible, it is far more likely that the child will instead replace the cup onto the table. This draws our attention to something that was overlooked in fig 3.6. i.e. the act of putting down the cup must be listed. This allows us to use our list searching rules in their present form to exit by responding to <fed up?>. This would take us up the list and along, rejecting the olfactory list until it comes to the drinking procedure list,

somehow it must avoid this list and move along to [put down cup] list. Later we shall see that the avoidance of the drinking procedure list is possible because the list structure can be of the form shown in fig 3.9

Summary

For the past two chapters we have made much of the lettuce leaves in a cup incident. We have represented the incident as a set of flow diagrams (figs 2.1 & 2.2) representing the change of behaviour. We then abstracted a general structure of embedded lists which we hope will allow us to describe a wide range of conditions. We have implied that the embedded lists can be restructured but as yet have not shown how thus restructuring might operate. We have also drawn out a set of rules for moving through our embedded lists. These rules are fairly precise except for conditions like <fed up?>. The later type of condition is intuitively meaningful but as yet we cannot describe it with any degree of precision. Furthermore, despite a great deal of theorising and formalising we are still unable to provide a full and unambiguous general notion of how cognitive transformations might take place, let alone apply that to the question of why the mentally handicapped child cannot play. The next chapter will bring us closer to a possible means of attempting to answer this question and the problem is taken much further in chapters 8 & 9.

CHAPTER 4 Integration and differentiation

Before elaborating further on the notions developed in the last two chapters it is perhaps advisable to be clear about the nature of what these notions are about.

In constructing the sort of model presented so far it is quite easy to fall into the trap of thinking that the subject is the model, and it is salutary to be cautious and remind oneself that the flow diagrams etc. presented here represent, not the child per se, but our ideas and theories about aspects of the child's functioning. In constructing psychological theories it would be nice to think that our theories are 'correct' in that they describe the psychological reality of our subject. However it is more realistic to recognise that our theorising, though aimed at describing psychological reality, probably falls short of that goal. Its evaluation then should be in terms of its usefulness in reaching towards that aim. In the clinical context another, possibly more important criterion operates in evaluating a theory: its contribution to developing effective therapy.

When we set about constructing models we are attempting to understand by the use of analogy. The example of a map provides us with some insights about such enterprises. At one level the map bears no relationship to the real world. It is not a miniature plaster of paris replication of the terrain. It has only two dimensions; parts of it do not change from green to gold in the autumn. If we put our ears to it we do not hear the gurgle of tiny streams.

In constructing a map we select a few features of the real world which seem useful for our purposes. These features we shall represent by symbols. Next, we set about measuring the relationship between these features and then, on a two dimensional piece of paper, we set out our symbolised features in the patterns that reproduce the measures relationships in the real world. A map then is only a representation of the real world inasmuch as it reproduces abstracted relationships. However, it is a useful device for armed with a map, compass etc., we can employ it to find our way about the real world.

Which relationships we choose to represent on our map depends on the purposes for which we intend our map to be used. A motorist's map is of little use to a geologist.

Maps can represent static states or dynamic states. A geologist's map represents the relationship between different types of rocks, soils, etc., and will serve to tell him where he is likely to find, say, limestone. However, if the geologist wishes to read from his map how the limestone got there in the first place then his map would need to take on a very different form and would somehow need to represent the process of geological change.

Constructing a map of the processes that are involved in developmental change in infancy is a hazardous operation, as the terrain that we are attempting to represent is inaccessible since the processes which we are interested in occur inside the infant's head. The investigator is then forced to make guesses,

and to induce the existence of features, or even systems, that may not in reality exist.

In the last chapter the basis of a model was developed which posited that infants operate by searching through lists of possibilities. In the use of conjuring tricks in hiding objects I demonstrated behaviours that infants operate as if they are following a list. This may partially be a function of how the problem was set up. So if a child's cognitive function is viewed from one perspective, it will appear to be list-like, and a map reflecting the list structure will serve that perspective. From another perspective, the list-like features will not emerge and that perspective is best served by another form of map. That is not to say that one form of map is necessarily superior to the other. It is a case of "horses for courses", and each perspectives' map will remain in currency until it ceases to be useful. Although in retrospect a particular map may appear to be misconceived it is certain that a contemporary map, through which perspective the old one appears misconceived, will itself be later judged to be incorrect. Each generation of map though will contribute to the development of later maps.

In this enterprise the feature that has been induced and abstracted from the hidden terrain is that of embedded lists and to put more detail into our map we need to try to answer the following questions.

(a) How might the structure of the lists change?

(b) How do new elements get incorporated into the lists?

Let's consider a child who can,

(i) Crawl.

(ii) Reach out and grasp objects.

Until a given point in his development these two areas of competence are isolated from each other and if an object is placed out of the child's reach it will not occur to him that he may crawl in order to retrieve the object. Later he will discover that his crawling will enable him to get close enough to the object in order to reach for it and play with it. Initially he may respond to this discovery with some delight and may crawl to objects for the sake of it. So, whereas once crawling for its own sake was fun, now crawling to a preconceived destination can be fun. Later the crawling may be taken for granted and become purely a means for getting at a desired object.

How could we use our embedded lists to explain this facet of development?

First we must make explicit an assumption that has operated in our account so far. Our notion of an embedded list implies that the child's entire memory, his repository of knowledge about his world, may be represented as a list. So a list model of our crawling child will consist of a long list of sublists, extending way back in time. These sublists will deal with specific competences, crawling, crying when hungry, going "goo-goo", reaching for objects, putting objects in the mouth, etc. The particular order of lists will vary, but let's follow what might happen to the initial configuration shown in fig. 4.1

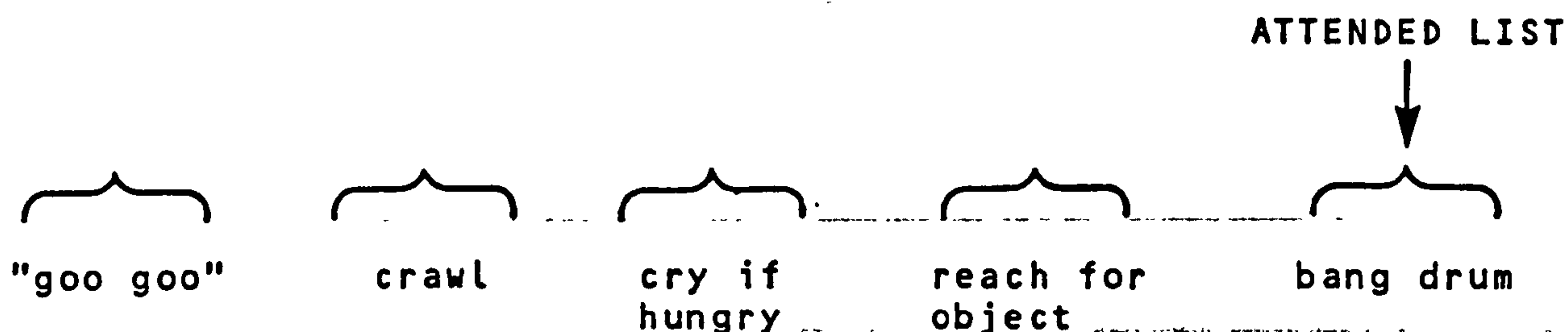

Fig 4.1 Sublist of competences.

A biscuit is placed out of the child's reach. He begins by working down his list considering each item in turn. The first item, [BANG DRUM] depends on the presence of a drum. So in its absence that particular list group is ignored. The next item is now considered, [REACH FOR OBJECT]. This item is appropriate except that the item is out of reach so the next item is considered, [CRY IF HUNGRY]. The child is hungry, so he cries. If he is lucky, mum will come running and hold the biscuit for him. If we applied the searching rules given in fig 3.8, our child would respond by going up list and along and would now commence crawling.

We'll give ourselves some licence and suggest that in this specific instance it would be useful if he had a rule...

<IF SUCCESSFUL GO BACKLIST>

useful, if a similar situation occurred in the future, for the two sublists to be lumped together into a procedure..

[REACH FOR BISCUIT, IF OUT OF REACH,
CRY, THEN MUMMY WILL GIVE IT TO ME]

Furthermore, making the assumption that the memory needs updating we can update fig 4.1 to the configuration shown in fig. 4.2

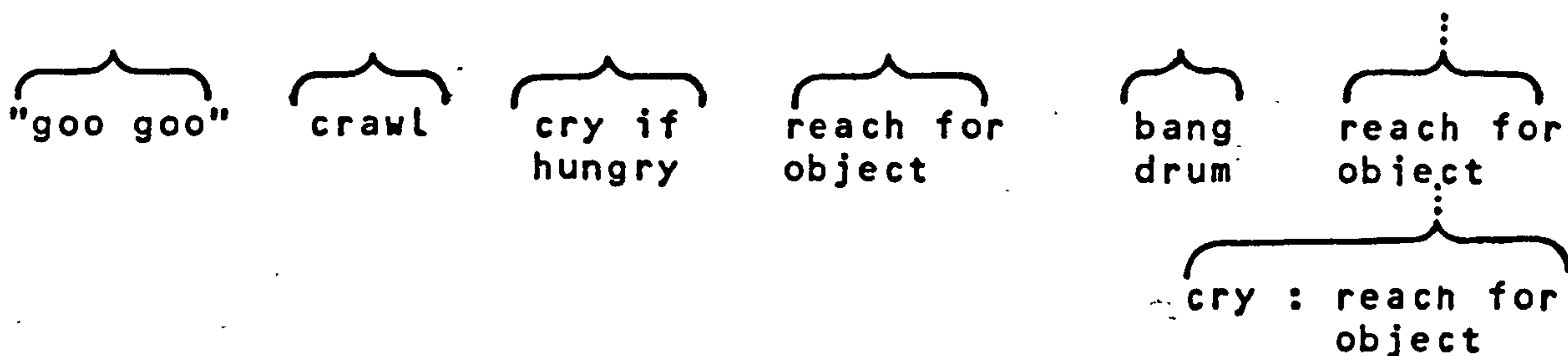

Fig 4.2 Updated sublists (1)

Let's now look at how the lists in fig 4.1 would operate if the object were a particular toy.

[BANG DRUM] would be scanned and ignored.

[REACH FOR OBJECT] would be attended to but rejected.

[CRY IF HUNGRY] is not operated.
(i.e. the child is not hungry)

[CRAWL] is attended to and operated.

Search direction now changes and..

[CRY IF HUNGRY] is not operated.

[REACH FOR OBJECT] is operated, as in Fig. 4.2. The list would be updated to record this particular episode to obtain the configuration shown in fig 4.3.

It should be kept in mind that this particular model does not attempt to account for the child choosing to crawl in any particular direction. Neither does it deal with the apparent ability of young children to anticipate, in this instance, that crawling will make the object reachable.

The procedures described so far would operate a rather clumsy automaton who would "tumble" into its solutions.

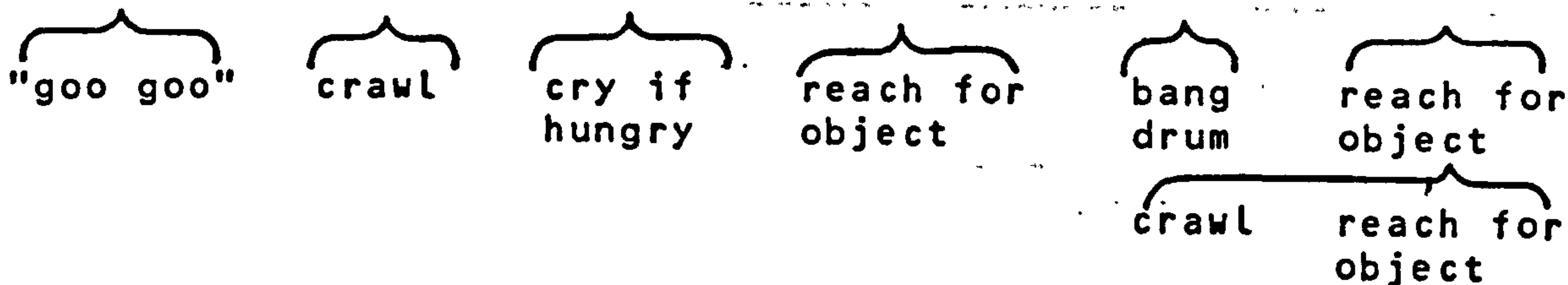

Fig 4.3 Updated sublist (2)

Related to this is the problem of how the lists in the concatenation should be ordered. If we decide that the item to be attended to first (even though it failed to operate in the first instance) is put first in the concatenated list then we have the happy situation where the list is addressed by the goal (i.e. the condition which allows a successful exit from the list currently being searched) and the solution (in this case [CRAWL]) would be attached to the intended act [REACH FOR OBJECT]. On the other hand, if the concatenated list were addressed by the first successfully operated list then attending to the act of crawling would have the implication that objects are reachable. (see fig. 4.4).

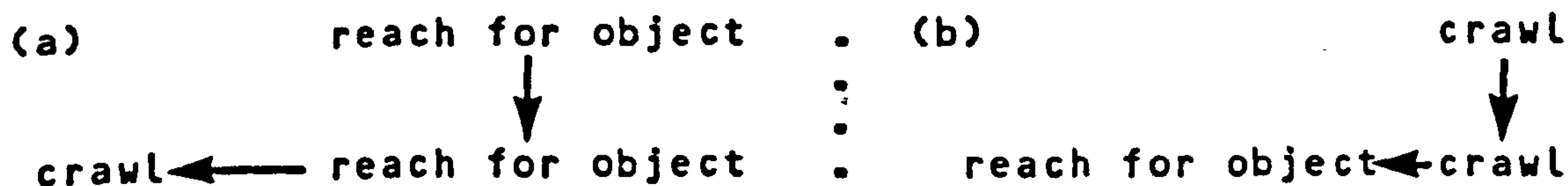

Fig. 4.4 Coding order of concatenated lists.

Let's give more substance to this idea of integrating separate areas by looking at a clinical anecdote where the idea of integration is used therapeutically.

Integration in Echolalia

Sadie is echolalic. She has a great deal of competence in handling speech sounds. If one addressed her with the utterance,

"What on earth are you doing now?"

Sadie would respond by repeating the utterance as likely as not word perfect, complete with the original intonation. Yet she has no language since she apparently cannot countenance the idea that words can have some relationship with the world. Even though her speech, viewed in isolation, seems at the level of a much abler child, her comprehension as measured on tests such as the Reynell Developmental Language Scales (1969) is minimal and she barely scores.

I had worked with Sadie for several sessions trying to teach her the names of objects, but to no avail. I was trapped in her echolalia. Prompts such as, "say ball", would be faithfully reproduced. Any verbal praise I gave would be liltingly echoed back to me..." good girl Sadie "!

Sadie's classroom was in a different building from my own room, so our sessions were preceded by a short walk to it. On route to the room she would dance, skip, and produce a variety of walks. She seemed to be playing, exploring different actions, different movements. A game developed on one journey. I held Sadie's hand above her head, said "turn round Sadie" and then

twirled her around whilst she was repeating " Turn round Sadie". Very quickly the game developed such that she would utter "Turn round Sadie", to which I responded appropriately. Within two sessions we were running, jumping, stopping, and turning round in response to her verbal commands.

Her progress since then has been slow but steady. She is still echolalic inasmuch as her vocal competence still outstrips her communicative needs, but the gap between speech and understanding is slowly diminishing.

What went on in this episode?

Strictly speaking, Sadie's use of speech in the episode was not symbolic. The act of uttering "Turn round Sadie" did not stand for or represent an action but was an action performed in order to produce a given desired effect. It is an item in a chain of events and the relationship between the utterance and the resulting action is the same as that in the "crawling for an object" example.

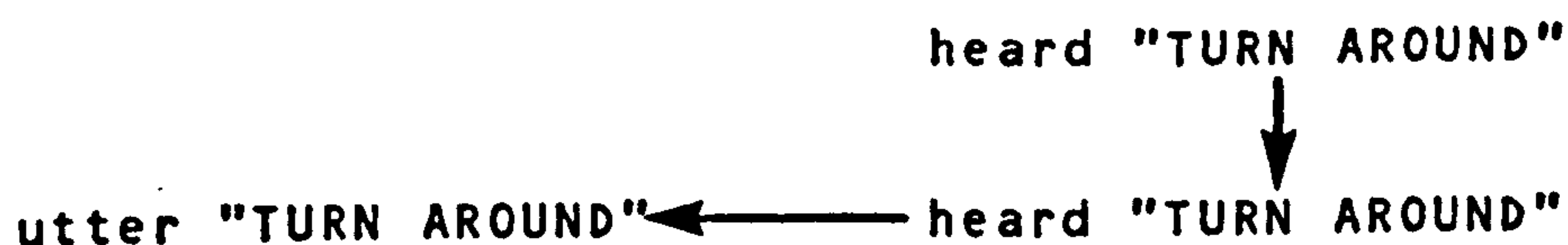

Fig 4.5 List structure of "turn around"

Let's suppose that following this incident I had said, "turn round Sadie", and she had responded appropriately, then the utterance would be symbolic. In terms of our embedded lists we could represent the event as in fig 4.5.

In response to my utterance Sadie would search her lists until she found the utterance, ["TURN ROUND"]. Normally she would respond in a typically echolalic manner by repeating the utterance.

The representation shown in fig 4.5 is a convenient fiction since it is not likely that Sadie carries a separate model for every conceivable utterance. A more realistic model would need to entail the breaking down of the utterance into their acoustic components and these would call up the appropriate mouth/voice forms. These would be assembled and operated as an utterance. Both versions have in common the idea of vocal action being operated.

For the symbolic response to operate Sadie would have to suppress her actions and move into the next list item, which is the physical act of turning round. (see fig 4.6)

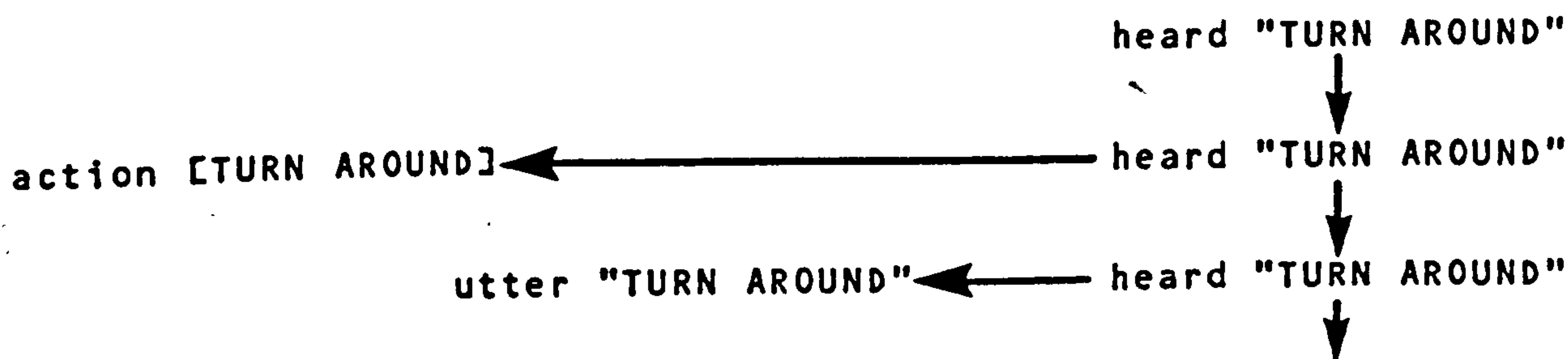

Fig 4.6 Extended list structure of "turn around"

We already have a potential candidate for this device in the form of the <FED UP?> condition represented in fig 3.8. But at a more intuitive level we might say that Sadie is much more interested in the action [TURN ROUND] and its contingency upon the utterance than in her reproducing the utterance yet again.

Car Driving

Driving a car is a situation which again demonstrates the notion of integration but which is more central to my own experience. In driving a car, I rarely think about what is involved in changing gear, I just do it. Now consider the acquisition of this skill. Not every car driver is a good instructor. The good driving instructor has, amongst other things, the ability to break down a particular package of abilities, such as changing gear, down to the same level of organisation as his pupil is competent to handle. He then demonstrates at this level. As the pupil gains in confidence he builds up his chunks of component subskills into bigger chunks. {the term "chunk" is a term for an organised bundle of information : Miller, Gallanter, and Pribram (1960)}. Eventually the pupil no longer needs to think about building up the elements which constitute a chunk such as changing gear, but starts to direct his attention to "learning to read the road." This entails anticipating and responding to the actions of other road users. This is another area of chunk building. Eventually the whole process of driving a car becomes "automatic" and the driver can engage in conversations with his passenger, unless road conditions become hectic in which case he will break off from his conversation and direct all his attention to his driving.

In addition to providing another instance of separate chunks of organised information being bundled together to form "super-chunks", the car driving example reintroduces the idea of metonymy, whereby the part stands for the whole.

When we drive a car we attend to limited features such as "road curves", and we respond to these features by the appropriate actions of steering. The experienced driver is not conscious of checking, "Am I oversteering...Am I understeering"? The act of steering is both fluid and unconscious, but the road curve engages the driver's attention and serves to call up the appropriate steering behaviour.

Paradigm and Syntagme

There are some differences between examples of metonymy, such as referring to a ship as a "sail" and examples such as a curve in the road ahead referring to "steer appropriately". The first example stands still as it were in time. The sail refers to the whole ship's existence. Jakobson (1968) termed the total system at a given moment the *paradigm*, as opposed to the *syntagme* which refers to the time based aspects of the system. Whereas in the "curve in the road" example the reference is to a sequence of actions which occur after the perception of the curve. In the crawling example the temporal distinction is even more clear cut.

Computer Simulation

To explore this notion it may be useful to look at the process of integration applied to our embedded list structures in a fairly abstract way. In order to do this I shall be introducing the idea of a computer simulation and this will allow us to explore other properties of our list structures. In effect this will entail designing a computer program that behaves in the same manner as the list rules and structures suggested in fig 6.7.

Usually psychology attempts to be rigorous by relating its data to a statistical model, which in effect serves to quantify our certainty about our psychological opinions. Computer simulation provides an alternative means of providing rigour by having recourse to a logical model. In effect it forces the psychological investigator to be utterly explicit about his assumptions and helps to show him the logical implication of these assumptions. It is a method that is well suited to the development of psychological explanations.

Colby (1978) built a model of a paranoid person. His main aim in this venture was to provide inexperienced medical students with initial experience of interviewing patients. At this level he was concerned with what Oettinger (1969) termed 'a functional model'. That is a model which focuses on the output of behaviours which are identical to the object of study without necessarily mimicking the internal behaviour of the object. This Fodor (1968) terms **weak equivalence**. However in developing the model Colby makes explicit some assumptions about the nature of paranoia. (The model starts from the premiss that the paranoid person has a story, or theory, which he wishes to relate to another person, but on the bases of an ongoing evaluation of the other person he decides whether it is safe, or not, to relate his tale.) In this sense Colby's model takes into account internal processes and is therefore a 'structural model' in Oettinger's terms. In its attempt to mimic a real patient, the model has conversational language capabilities and the student interviews the machine via a teletype, without knowing that it is a machine. However, although

the language of the machine is suprisingly convincing it does not necessarily follow that the processes that generate the language are those employed by people. Fodor requires that for a model to be strongly equivalent it must be in effect both a structural and a functional model. So Colby's model of paranoid process would have strong equivalence but as a model of human language it is likely to be weakly equivalent.

Most psychological enterprises involving computer simulation have been investigations of cognitive processes, especially semantic memory {e.g J.R.Anderson and G.H.Bower (1973), A.M.Collins and M.R.Quillian (1972)} and as such are structural models. Since the flesh and blood processes towards which these enterprises are directed are not available for inspection it is very pertinent to ask, "How do we know that these models bear any relationship to the psychological reality of real organisms?"

A.Turing (1950) devised a rigorous test which required in effect that the structural model behaved as a functional model and that if interrogated it would be indistinguishable from a real organism. These are very stringent requirements but they can be relaxed by requiring that the test be addressed to what Fodor terms the appropriate level of description. A psychological explanation is necessarily an abstraction and in order to be fair to the model the Turing test must be addressed to the appropriate level of abstraction.

In the present context the computer simulation will involve building list like structures in the form of computer programs in order to examine how they behave and to draw comparisons between the behaviour of the model and that of children, particularly

mentally handicapped children. In choosing this form of investigation we are restricting our options. My own experience of myself operating in the world is in terms of images and it takes some effort and contortion to discern that my own use of images could be described as a linearly operated list structure. It would take a very different form of technology from the digital computer to deal with the visual non linear aspects of my experience.

To avoid confusion between the computer model and a real person I shall give the model a separate identity by referring to it as BABEL. So whilst we shall be keen to demonstrate similarities between BABEL and a real child, we will be aware that they are not the same thing.

Abstraction

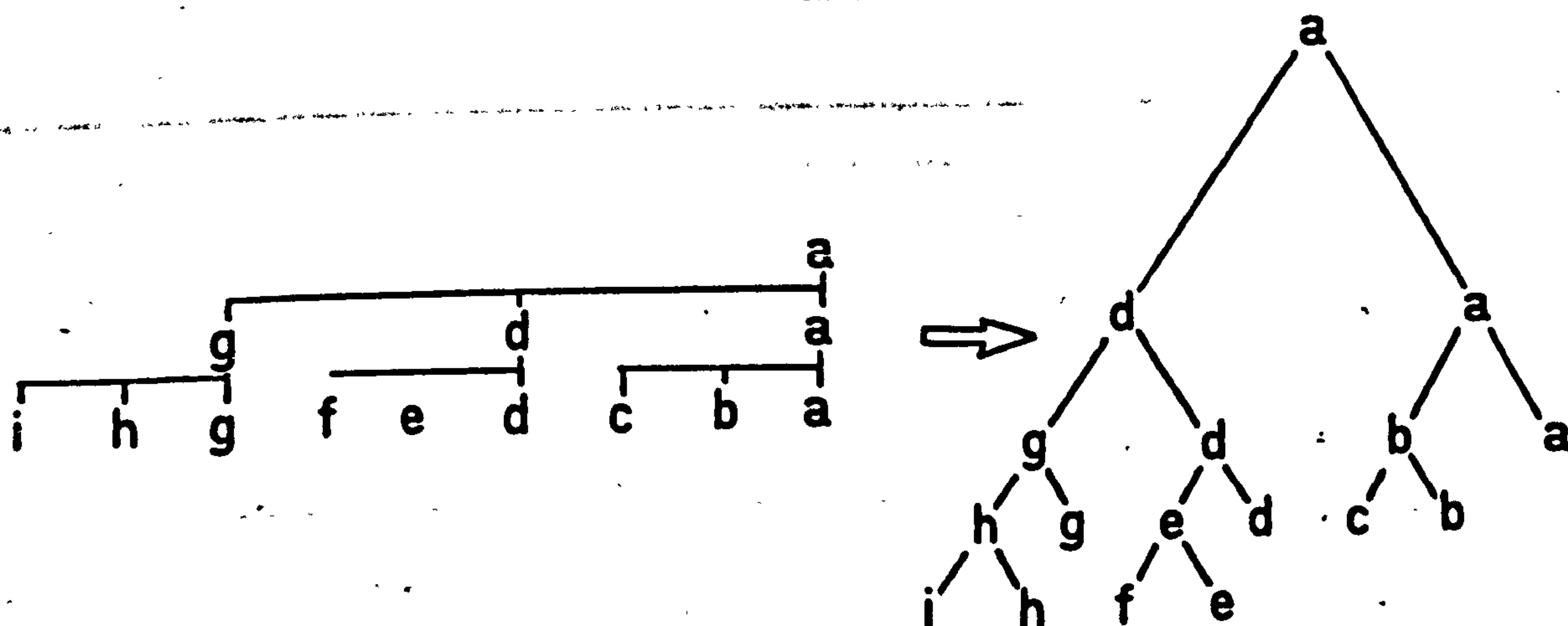

Fig 4.7 Translation of embedded list representation into binary tree representation

So far we have talked in terms of embedded lists, but we can represent exactly the same relationship as binary trees (see fig 4.7)

Integration in BABEL

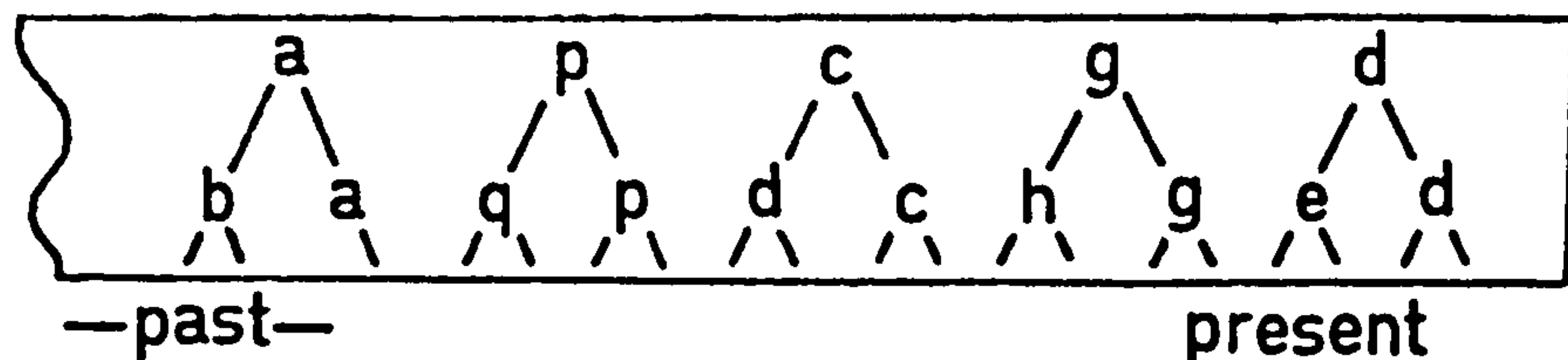

Fig 4.8 BABEL'S basic memory structure.

BABEL's main aim as a system is to attempt to follow what is happening in the environment. So given a memory configuration as in (Fig 4.8) and the presence of the following attributes in the environment...A,G,Q,R,B,S,V.... (Items in memory will be represented by lower case letters, items in the environment by upper case letters). BABEL begins its memory search by first considering (d), the most recent event in it's memory, fails to find it in the environment, so then considers (g), rejects it and moves onto (c). (C) is detected as being present. If we examine the contents of the chunk addressed by (c) we note that additional elements {in this case (d)} are coded. BABEL however is content to assume that whatever is addressed by (c) is present and engages in further search. Element (p) is now considered and rejected since it does not presently exist in the environment. Search continues and (a) is considered and accepted since attribute (A) is presently found to exist. Again BABEL is content to assume that the information addressed by (a) is present

without checking it out.

The reader will note that the process described here is exactly the same as that found in fig 4.1, but letters are used instead of real behaviours and events.

BABEL finds it useful to record that..

[FIRST (c) WAS FOUND AND THEN (a)]

and the coincidence of these two chunks is added to BABEL's memory, as shown in fig. 4.9.

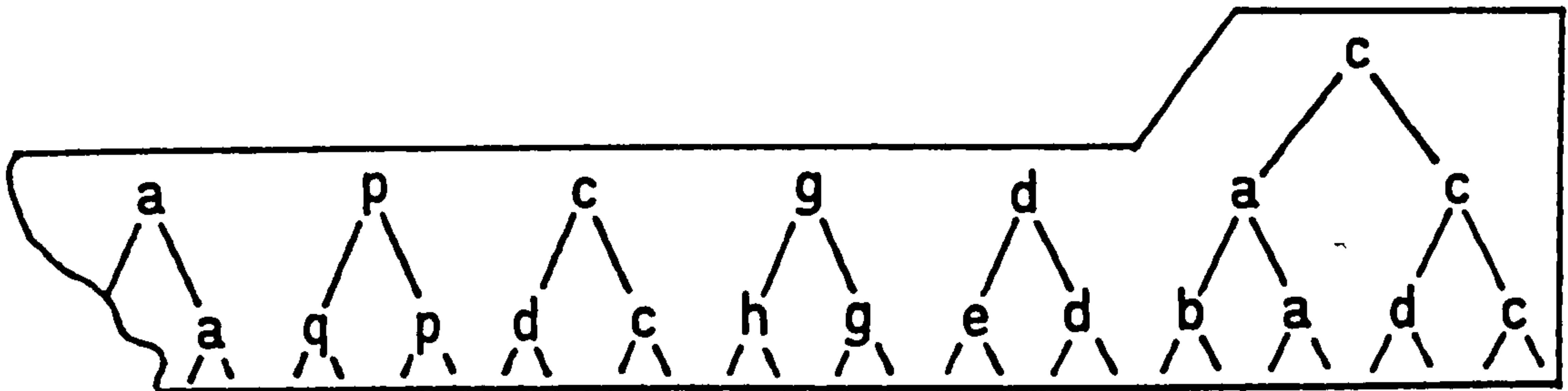

Fig 4.9 Integration of coincidence

There are several implications to this coding of coincidence.

- 1) On a subsequent occasion, given the presence of (C) BABEL can assume that (a) has also occurred and expend its efforts in integrating additional information to (c).
- 2) The addressing of the integrated chunks is taken over by the element which addresses the first chunk found.
- 3) The assumption that the contents of a chunk are present in the environment without checking up on them is risky and BABEL might be said to be

optimistic when taking such risks. Later we shall make much of this when we shall allow BABEL to be OPTIMISTIC or PESSIMISTIC.

4) It has already been pointed out that both events which occupy a particular instance in time and sequences of events can be coded as chunks, and there need not be any structural difference between these two types of chunks. The notion of chunk integration makes this clearer.

Since the world is ever changing, when BABEL sets out to map what it finds in its memory onto what is in the world it is confronted by this fact. Memory search takes time but the time taken to locate a particular item depends on that item's accessibility.

Furthermore, dealing with information embedded within a chunk (unconscious) takes time and the more information dealt with the greater the time taken.

At a simple level we could say that if memory search, and/or chunk processing is brief, then the world for the duration of the search is coded as if it were static. If however the search and the process time were increased then a portion of the world would be coded as a chunk whilst it is in the process of changing. A chunk formed under these conditions would contain information about the world before, during, and after a change had taken place. If a chunk is called up which operates an action, then that action, if appropriate, will change a large proportion of the world and again the world will be coded as changing.

The point raises the question of how BABEL realises that an action is appropriate. It would seem possible that an action would not produce any change in the world, yet BABEL might assume that the world as it exists after an action is in that state as a result of that action being applied.

That this happens in real children is evidenced by instances where the infant has a "magical" notion of causation, and he tries to reproduce an event that coincided with a particular action by repeating that action, even though there is no causal relationship. It would seem that infants, like many psychologists, (Tversky & Kahneman (1979)) are prone to infer causation from correlation.

To deal with this situation we need to examine the possibility raised earlier, that BABEL operates memory searches both forwards and backwards in time.

Search Directions

I ask myself to think of something that happened many years ago. I think of the coronation. What I experience in remembering is an image of the crown being placed on the Queen's head, an event. As I ponder over the image, I can construct more, I can see whole episodes. So though I went backwards in time in order to remember the coronation, once I locate the appropriate image then I follow the sequence of events forward in time. To remember what happened before or after a specific episode though is harder work, and it would seem that I am working within the boundaries of an episodic chunk. Furthermore, even though we can remember

the individual episodes that make up a particular scenario it is often quite difficult to put these episodes into the right order, and this might be, to a certain extent, accounted for if our memory search at the level of the scenario was moving backwards and forwards.

So for instance, as I work on my memory of the coronation I get an image of carriages being drawn through London but I am uncertain whether my image is of the journey to or the journey from Westminster Abbey.

We might posit that in trying to remember something we search backwards in memory until we locate what we are looking for. Then our search changes directions and moves forward. If the forward search fails, then we again alter search direction and now search backwards.

Whenever we attempt to formulate an explanation of a complex area with any precision we find that more questions are raised. In this instance we have posited the rule.

< SUCCEEDING>?..... yes - search forwards.

no - search backwards.

Two questions are raised here. First, "What is meant by succeeding?". It might be said that BABEL's primary task is to recognise an identity between what is happening in the outside world and a particular section of its memory. In other words BABEL tries to experience the world as being familiar. In so doing it operates memory searches which take time. If BABEL is

too slow it will never keep abreast of events, so there is a need to make searching as economical as possible. Our notion of "success" then needs to take these issues into consideration.

The second question raised here is, "How strict is the <SUCCEEDING?> condition. i.e. If in searching backwards a target item is found and the search changes into a forward direction, does the very next item found have to relate to the search task or would it be appropriate to build into our system some looseness and give it some tolerance of failure? In order to allow BABEL to sort out contingency from coincidence it is necessary for it to have some slackness in its search direction criterion.

Contingency and Coincidence

To follow how BABEL sorts out contingency from coincidence we'll recreate, step by step, a BABEL run.

Assume that a section of BABEL's memory is as in Fig 4.10.



Fig 4.10

For simplicity we shall adopt the convention of ignoring the internal structure of our chunks as shown in Fig 4.11

Events D, A, L, & M occur in the environment and BABEL commences to search backwards, considering in turn, k, j, i, e, b, j, until (a) is found. The match between BABEL's (a) and the existence of (A) in the world is noted. By now, though, the world

has changed and (D,A,B, & M) exist. BABEL changes search direction and now considers (f) before finding the next item (b) occurring. The coincidence during the search is noted and added to the memory to give us the state represented in fig 4.12.

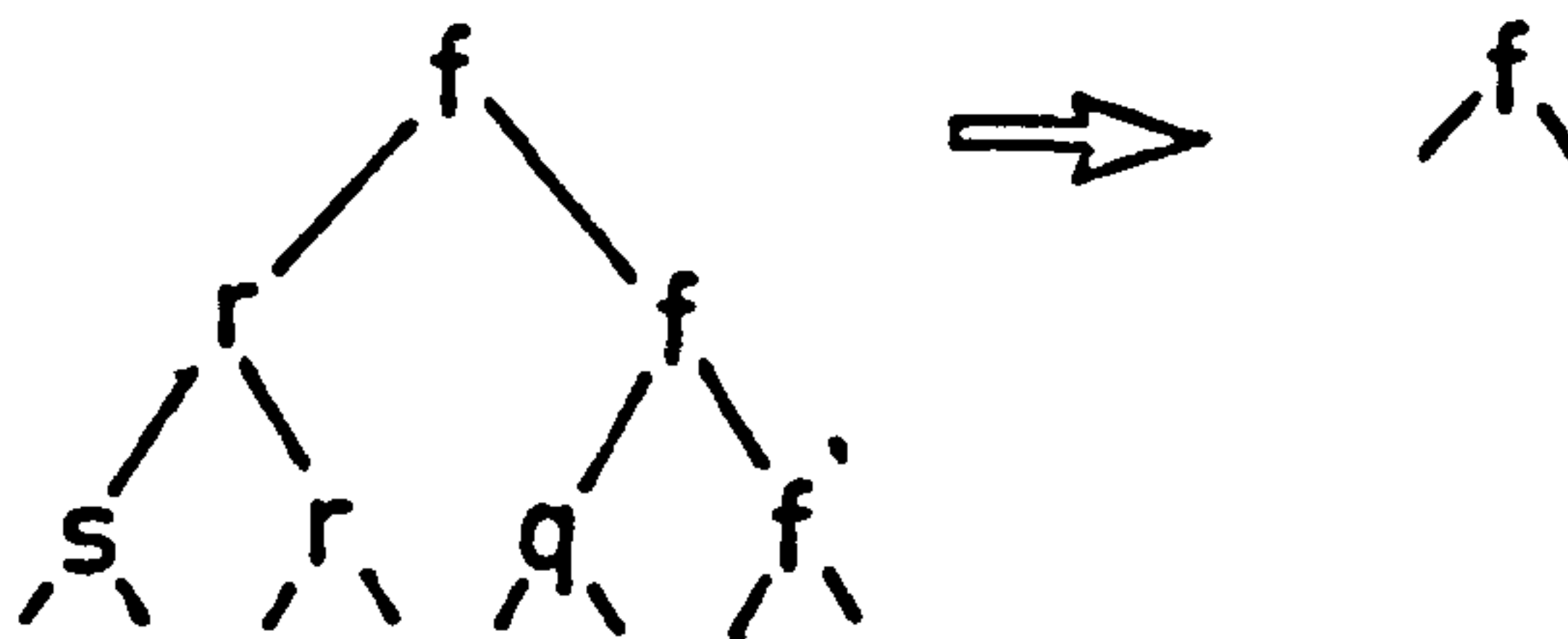

Fig 4.11

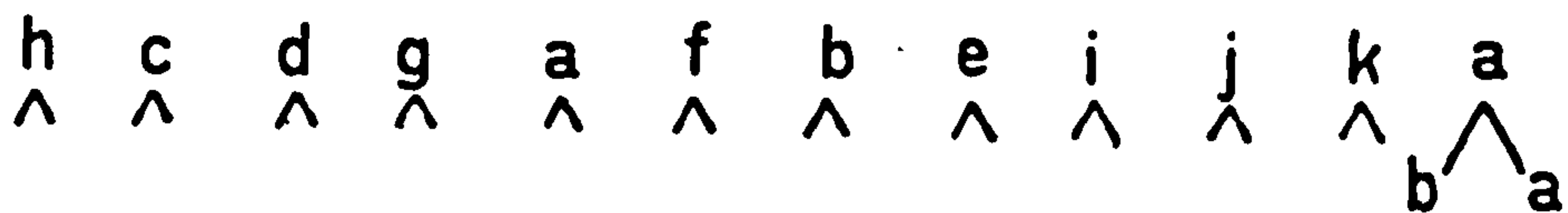

Fig 4.12

The existence of both (d) , which was locally available, and (m) in the world is ignored. If the world now changes to include, say (I), BABEL would begin a back search, locate (i), then begin to search forwards. Let's assume that the world now changes to include (K). So (i) and (k) would be integrated and fig 4.12 updated to fig. 4.13.

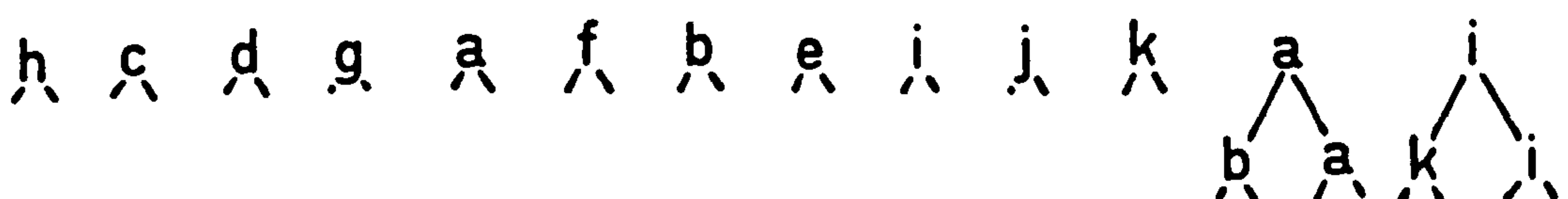

Fig 4.13

If the same situation arose subsequently BABEL would refer to (i), not find it, then refer to (a) and find that. The updated (a) carries assumed information about (b) and this need not be attended to. The sequence [(a) THEN (i)] would be added to give us fig. 4.14

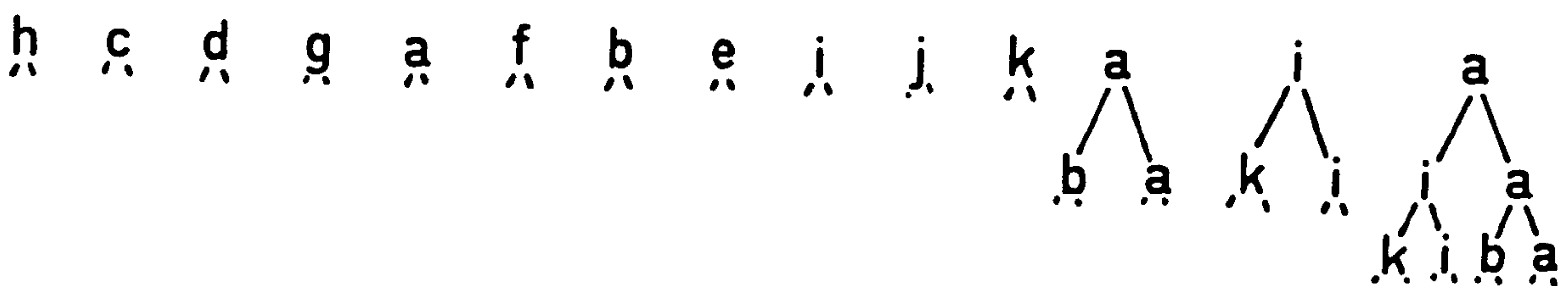

Fig 4.14

In following this procedure BABEL has succeeded in abstracting a sequence of events from a background of other events which do not occur in this particular instance. However this does not preclude the possibility that some of the events coded in the sequence are variable. Let's go back to the configuration shown in fig 4.13. We'll go through the same sequence, but this time (I) does not occur. So as before, BABEL refers to (i), does not find it, searches back to (a) and finds that (A) does occur. Search direction now changes and (I) is referred to, but this time (I) does not occur. The search now moves backwards, (a) is passed over and (k) referred to. (K) is found and concatenated to (a) to give us the state represented in fig 4.15.

So the hypothesis that (a) is followed by (i) is dropped. If it were the case that (i) but not (k) followed (a) then BABEL would have problems. So far BABEL has been typified as operating

optimistically making assumptions and operating on them.

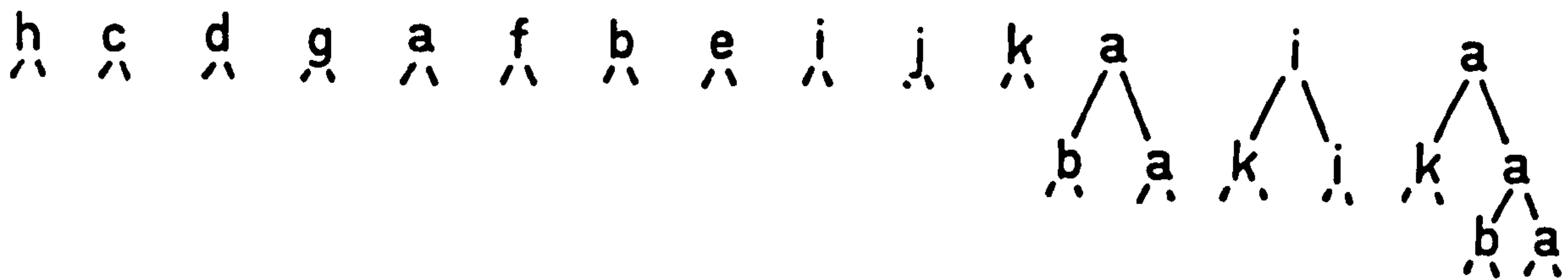

Fig 4.15

In the example of car driving presented earlier, the instructor was typified as having the ability to "unpack his chunks" and to present and communicate the subunits of his driving competence at the level at which his student operates. From this level he set about enabling his student to integrate these subunits into larger and larger chunks.

An experienced driver can carry on a conversation with his passengers whilst driving. In this state he is barely aware of his driving activity although he seems to be doing some spot checks on what is going on. So he is operating his 'chunks' as a means to an end, and it is unlikely that he is doing anything like the integration process we have just discussed unless he is learning something from the conversation.

However, if traffic conditions become hectic, or something happens, he breaks off his conversation and attends to his driving. His relationship with his driving activity is changed and he is not making assumptions to the same degree as he was previously. He unpacks his chunks and checks the veracity of data he was formerly content to take for granted. The process of unpacking is shown in fig. 4.16

The degree to which he unpacks would depend on the "pressure" on his driving, and on the degree to which he needs to restructure his plans. There would however be limits to this degree of unpacking. It is not likely that he would, for instance, check how his fingers are coordinated to grasp the gearstick.

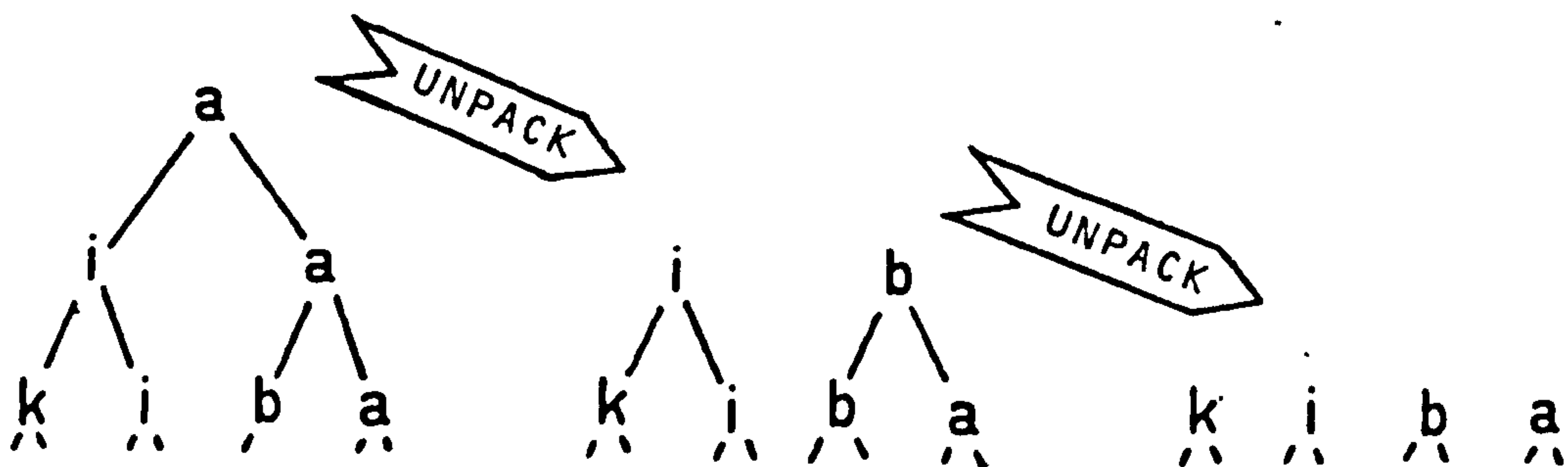

Fig 4.16 The process of unpacking.

Pessimism

We can build the notion of unpacking into BABEL by giving BABEL a choice between being optimistic or pessimistic depending on its experience of its own success.

In Fig 4.10 , 9 chunks were considered in the search process; in Fig 4.13, 3 chunks were considered, in Fig 4.14 only two possible chunks were considered. The process of integration greatly reduces search time. We could set the system to be pessimistic in its early encounters with a particular sequence of events. This would greatly increase search time but it would contribute to greater certainty later when making assumptions

about the world.

So although BABEL's early perception of a sequence would be "magical" it would, over a period of time sift out the invariable items.

Differentiation

Consider the following situation. I walk into a clubroom full of elderly looking gentlemen and say,

" I saw a hairy today! "

Were the gentlemen members of an elite conservative association, they might respond,

" Humph, deserve to be flogged, social parasites..etc."

However, were they members of the local entymological society, I might be asked information about its colour, markings etc. If I am reasonably certain that my companions share my assumptions and attitudes, then all is well, but if I am in anyway out of touch with my social context then I may get into some misunderstandings and I may need to inform my entymological friends that this particular hairy had a guitar.

In this example, metonymic coding was employed but the coding was ambiguous and it became necessary to disambiguate the metonymy by making explicit another part of the image referred to. We can build the same process into BABEL by the process represented in fig. 4.17

BABEL's ability to differentiate is very useful where the items in the chunk are co-occurring. In Candy's case presented in

chapter 2 & 3, we could say that "the presence of a cup" as a coding for the whole procedure was ambiguous and she learnt to differentiate between cups full of drink and cups full of lettuce leaves, and we could represent the development of her ability to discriminate as a process of bringing more and more information to the top node of her drinking procedure.

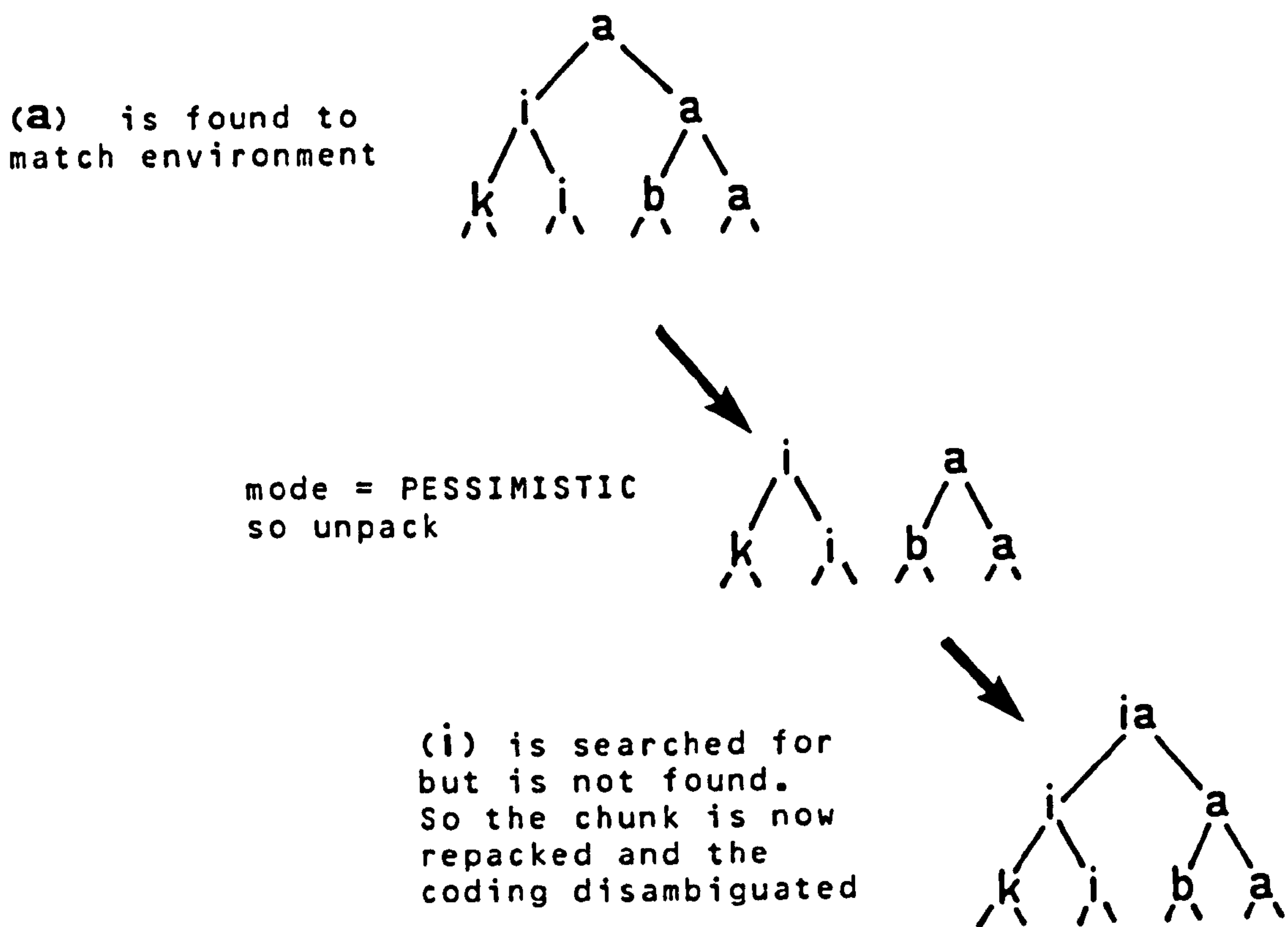

Fig 4.17 Disambiguation

There are some serious problems though in this typification of the process of differentiation and it may be that we are getting into an area where the analogy is stretched. With some further effort the analogy might be extended to fit our domain of

interest, but it may be the case that to consider these areas we might have to adopt an analogy with a very different structure, but that is a topic for another book. Let's consider some of these problems.

Overloading

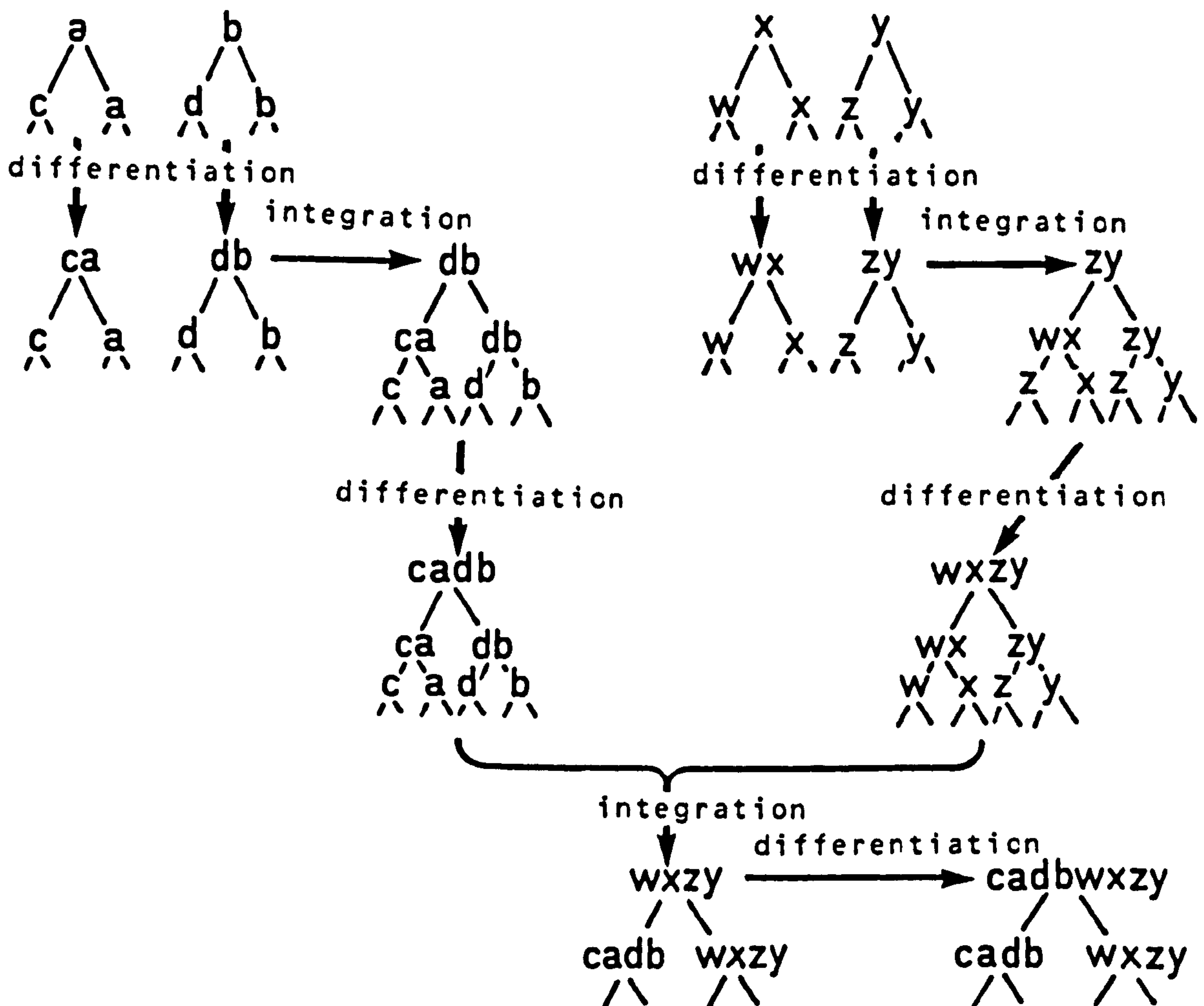

Fig 4.18 Successive operations leading to overloading.

It is very easy to set up a situation where, through successive differentiation and integration, the number of attributes coding a particular chunk becomes unmanageable. (see fig. 4.18)

Where the number of addressing attributes is small, there is no need for any structuring. A large field of addressing attributes would need to be structured by some means so that the task of searching the field is adequately organised.

One method which we might contemplate would be to simply repeat the hierarchical process that BABEL already employs, but to employ the disambiguating features as the addressing features. The distinction between "simple" differentiation and "hierarchical" differentiation is further shown in fig. 4.19

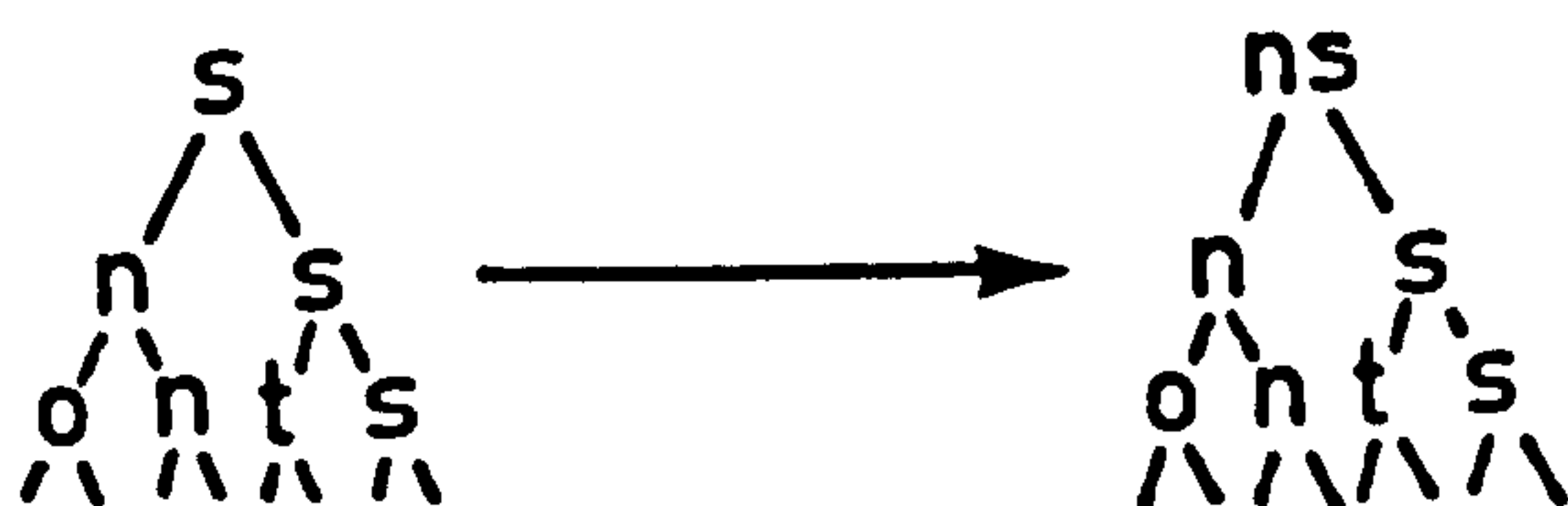

Fig 4.19a Simple integration

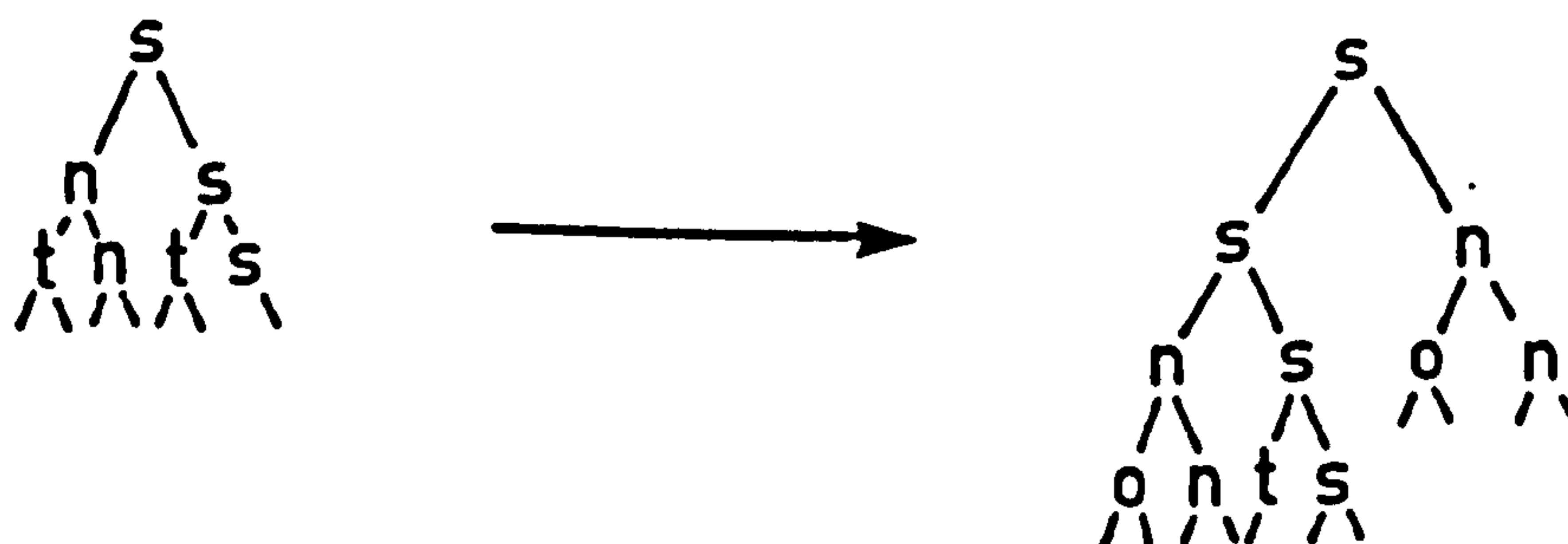

Fig 4.19b Hierarchical differentiation.

Although it serves well in allowing the reorganisation of attribute importance, the use of hierarchical differentiation may seem cumbersome and redundant when our chunks deal with co-occurring attributes. When the chunks are of such a size that they cover sequential information, there are some interesting consequences.

Consider the following configuration (fig 4.20)

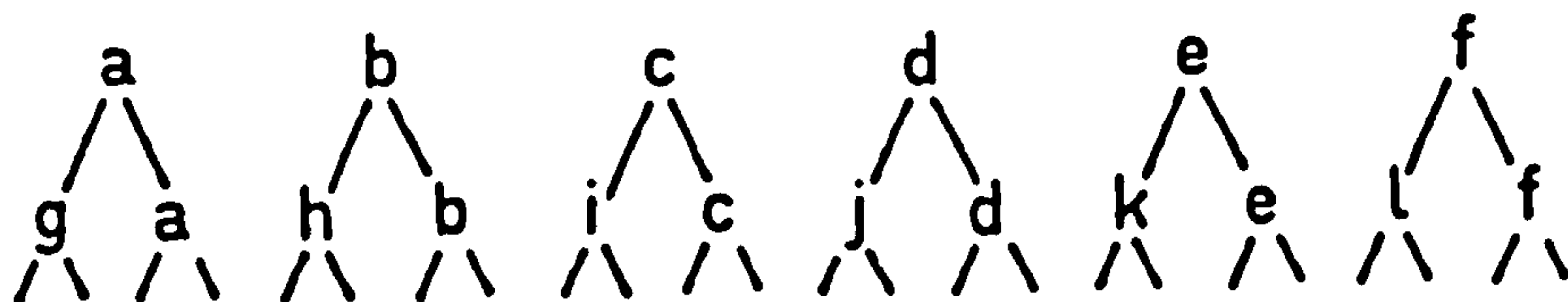

Fig. 4.20

Let's suppose that BABEL is operating in an environment where at a given moment the sequence $A > C > D > F$ occurs.

At this moment (A) is occurring so a backward search is initiated and (a) found. Search now changes direction, but at the same time the environment is moving through the $A > C > D$ sequence, so (C) now is occurring. The sequential occurrence of $A > C$ is coded as in fig. 4.21

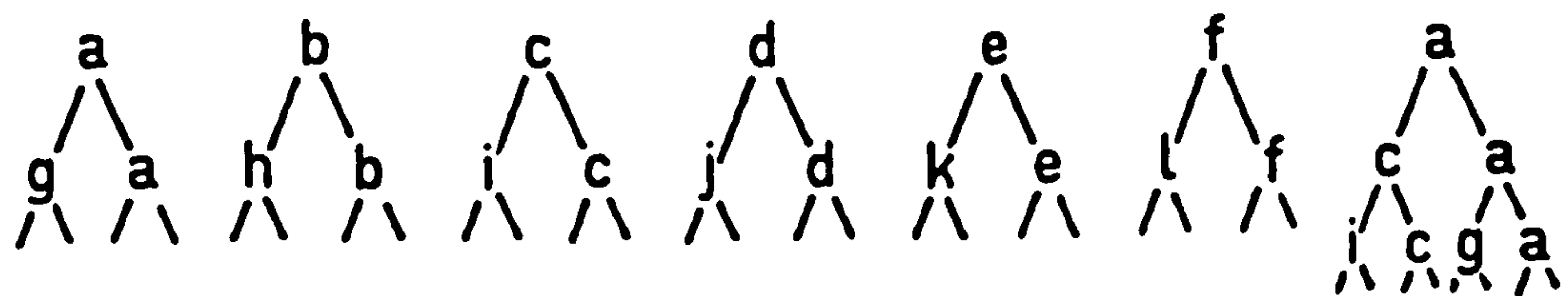

Fig 4.21

The search continues and the $D > F$ sequence is coded.(Fig 4.22)

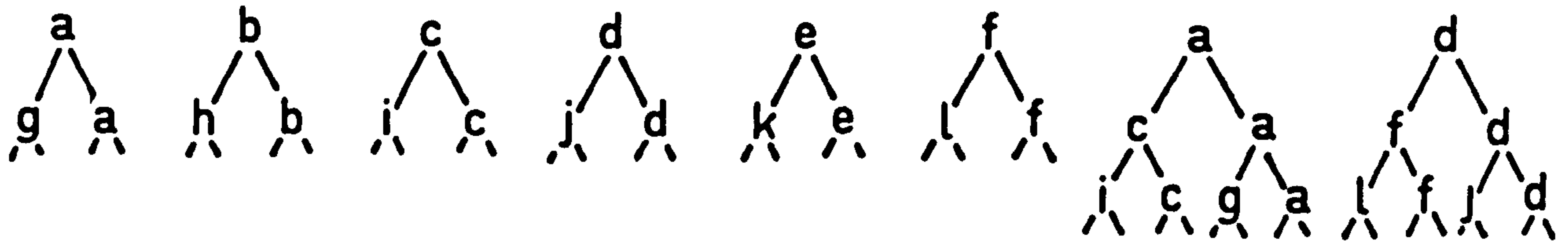

Fig 4.22

In a repeated scanning of the same sequence we have (A) is again found and (F) is anticipated, but (F) has not yet occurred. Unpacking at this point would make (c), the next item in the sequence, accessible. However, if the coding is altered as a hierarchical differentiation we get the state described in fig 4.23.

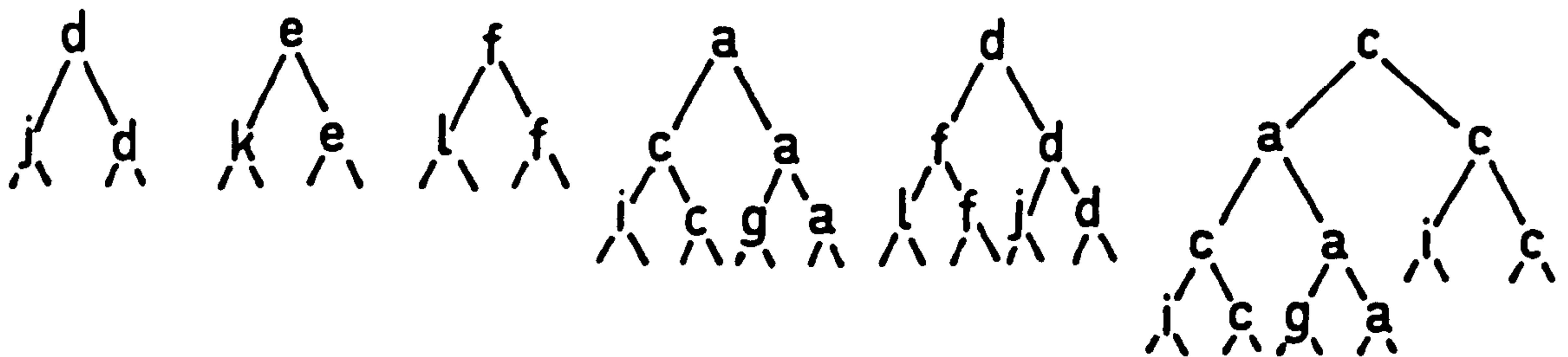

Fig 4.23

Whilst this form of coding raises difficulties in handling search directions the consequences of addressing a sequence by an anticipated state is important since it allows for the possibility of searching for a goal and using that goal to call up the sequence that leads up to it.

This points to another aspect of human cognitive functioning that BABEL in its present form does not handle. BABEL, as it has been described thus far, operates by trying to build a data structure and mapping it onto the ongoing events in the environment such that it anticipates events. As a theory BABEL focuses on the nature of the data structure and also on the processes which organise the mapping between the data structure and the environment.

However, much of human activity involving planning and problem solving involves organising mapping relationships between personal data structures as well as relating these to the environment.

This presents us with some fascinating questions. However, it does seem, from the author's point of view, that we can gain more understanding of what distinguishes a mentally handicapped child from a normal child by focussing on the issues involved in understanding the management of success and failure in processes of the type hypothesised in this chapter.

This theme is taken up in chapters 8 & 9 where an attempt is made to extend the model in that direction.

The notions of integration and differentiation have considerable utility in providing us with a means of developing an overview of sensori-motor development and some differential diagnosis of specific problems that mentally handicapped children encounter in covering 'the sensori-motor syllabus'. The nature of this syllabus is reviewed in the next chapter.

The Suppression of Action

In the same way that BABEL needs to choose whether it needs to be optimistic or pessimistic, to integrate or to differentiate, BABEL has another dimension of choice and that is, whether to ACT or not. In the early discussion of list structures, actions were structured in the same way as sensations. In other words a list item could refer to a set of sensations or to a set of instructions, and depending on the nature of the event being coded, sensations and actions could interrelate in a variety of ways. In BABEL's representation this means that coded items could have either status. The nodes in the hierarchies may refer to inputs or to outputs. We will not make much of this feature in this presentation but this dimension of choice has important implications for cognitive change.

Consider the following problem set to a toddler. A desired object is placed in a low cupboard. In front of the cupboard drawer is placed an obstacle light enough for the toddler to move. One toddler approaches the cupboard, pulls it open, discovers the obstacle, and then moves it out of the way before returning to opening the cupboard door. Another toddler will approach the door, move the obstacle out of the way before attempting to open the door. This second child has demonstrated the ability to imagine himself operating the action of opening the cupboard door. In this act of imagining he has anticipated the problem. The first infant encountered the problem in the execution of the act. The second infant 'planned'.

If we attempted to model this with BABEL the process would proceed something like this. The first infant would call up the chunk [OPEN CUPBOARD] and attempt to operate it. The obstacle would induce failure and so the chunk would be unpacked, compared to the ambient situation, a solution would be searched for and [MOVE OBJECT] implemented. The second infant would call up the [OPEN CUPBOARD] chunk and operate it, but in operating this chunk he would decide not to implement any actions called up during his operation of the chunk. This would allow him to call up the image of himself implementing the actions and the previous consequences of his action. A mismatch between this scenario and the confronting situation would invoke the same back search that made [MOVE OBJECT] the first infant engaged in. This could be incorporated into the [OPEN CUPBOARD] chunk, possibly checked out under the same condition of choosing not to act, and then finally and successfully implemented.

PART 2.

THE SENSORY MOTOR CURRICULUM

Towards a functional cognitive assesment of the mentally
handicapped child.

CHAPTER 5 a sensory motor curriculum.

INTRODUCTION

Attempting to understand the nature of playlessness implies that given this understanding we may be in a position to talk about therapy. In an educational setting this could be interpreted as knowing how to educate a severely or profoundly handicapped child. Let's assume that we have the benefit of such understanding and we know how to teach. We still need to know what to teach. In other words we need a curriculum.

A curriculum means many things to many people and the topic of curriculum design has enjoyed a recent fashionability in normal school education. Inevitably, this fashionability has spilt over into special education.

In educational philosophy, two opposing extremes can be discerned which seem to arise from assumptions about human nature.

- 1) Education should provide the child with the knowledge and skills necessary for his future life such that he will be a useful member of society.
- 2) Education should be about the provision of opportunities within which the child can develop his own potential

The curricula that arise from the first position are pragmatic. From a psychological point of view they imply a behaviourist position inasmuch as the onus of responsibility for curriculum design is vested in his cultural environment. The

child here is seen as a passive recipient of the wisdom of his elders.

There is another, opposing version of pragmatism, wherein the child is seen, not as a tabula rasa, but as a savage needing to be trained and civilised. This is the moralistic victorian pole of pragmatism.

The nature of a curriculum for the idealist is problematic, inasmuch as it implies that the child is privy to his own curriculum. From a psychological point of view an innate position is implied. This simple interpretation of the idealist position would lead to the absurd statement that, say, knowledge of the periodic tables is innate.

This is a gross distortion of the idealist position which would propose that a child's natural curiosity, his innate ability to acquire and organise his own experience, leads him to the most useful understanding of the world of which he is a part. The notion of a curriculum would meet with some suspicion from an extreme idealist.

In practice, the consensus within our culture seems to assume an idealist position for infancy, but has a tendency to operate a pragmatic position which increases with the age of the child.

The assumption of an idealist attitude towards infancy is not straightforward. In areas of competence, such as walking,

talking, etc. where there is no controversy about the nature and content of the competence, parents seem happy to adopt an idealist position, and few parents would claim to have taught their children these abilities. Areas such as toilet training, demand verses schedule feeding, which have connotations of morality, personality, and about which there is controversy, seem to elicit a pragmatic stance from parents and they are happy to see themselves in a training role.

Bruner (1972) has an interesting and rather controversial suggestion. Given that child rearing practices are "designed" to prepare infants for a specific culture, parents in modern industrial societies have a problem inasmuch as they are not in a position to know what sort of culture their offspring will grow up to be part of. He suggests, rather controversially, that the adolescents have their fingers closer to the cultural pulse and are therefore in a better position to provide appropriate child rearing practices.

In the non controversial areas of infant competence, the normal infant appears to educate himself with remarkable ease and proficiency {R.A.Brown (1973)} though in reality parents play a powerful but subtle role in this process.

The mentally handicapped child encounters considerable developmental problems and may give up the struggle and become stuck at a particular point in his development.

The existence of an intrinsic ability to learn is a presupposition of the idealist educator so that when he is faced

with a mentally handicapped child his basic tenets become untenable and , if he is to operate in the field, he is forced to shift his ground and become more pragmatic. This may induce him to invoke the notion that there are two kinds of human nature, which may produce an uncomfortable conflict in his ideology.

In his practice he will be forced to countenance the idea of a curriculum and he may attempt to resolve his ideological conflict by looking to normal child development for a curriculum.

The pragmatist's curriculum may be structured by considering what skills and competences are required to live a normal life and set up these skills as training goals. A normal adult though employs a very rich repertoire of abilities, in working, in relating to others, communicating etc., and the prospect of training such a complexity is daunting.

The pragmatist has some very real problems in deciding what subsets of the normal adult competence should be in his curriculum. A realistic and useful response to this is to recognise the limitations of one's own training method and to limit the contents of the curriculum to those items which can be taught, given the skills of the educator.

In practice the recognition of one's own limitations is threatening and there is a tendency to ignore those areas of competence which are untrainable. The result is a very abridged version of a normal adult's competence. The "successful" mentally handicapped person, when viewed in this framework,

polishes his shoes and teeth regularly, folds his trousers neatly on the chair at night, reports punctually to work which may consist of putting cotton wool balls in paper bags.

Some of these issues are highlighted in the study of language acquisition and the application of this understanding to the problem of retarded language acquisition in the mentally handicapped.

An early formal approach to the understanding of language acquisition was that proposed by behaviourist psychologists such as that of Skinner (1957).

The acquisition of language was seen as a process whereby correct responses by the child were shaped and reinforced by the parents. The approach said little about the structure of language (however see Staats, 1969) and places the responsibility for the program on the environment.

This point of view was optimistically adopted by people working with the mentally handicapped since it gave considerable hope that something might be done to help the many hundreds of mentally handicapped children who had no speech.

Skinner's position came under some very strong attack from Chomsky and Miller (1963) who argued that using the process Skinner proposed, it would take many thousands of years to acquire the linguistic competence of the average adult. Chomsky also emphasised the generative quality of language. i.e. the idea that an utterance could be utterly novel. He argued that any

account of language should take this creative aspect into account. Chomsky's earlier work focussed on the syntactic aspects of language, and his aim was, in principle, to write a grammar, the minimal set of rules which would generate a given language.

In contemplating the ease and rapidity with which normal children acquired this complex body of rules, Chomsky and Miller commented that what the child did was either miraculous or impossible!

They opted for the "miraculous" explanation, the miracle being that the child had a ready made structure which he employed to master his mother tongue. They further appeared to postulate that this language acquisition device was in some form innate.

The implication of Chomsky's work are pessimistic for those working with the non speaking mentally handicapped in that the problem becomes insoluble, and writers such as Lennenberg (1967) reinforced this pessimism.

Naturally, those working on helping the mentally handicapped despaired of learning anything from psycholinguistics and for many years were ignorant of subsequent developments in the field.

Academics such as Slobin (1973) did not accept the innatism of Chomsky and in effect opted for the explanation that the toddler managed to do what Chomsky and Miller termed "the impossible".

The cognitive position in effect accepts that the child has a ready made structure but maintains that this structure is acquired during infancy and is a "cognitive, perceptual structure". Developments from the cognitive position have increasingly emphasised the social nature of the infant's learning. {e.g. Bruner (1975)}

The implications of this for the mentally handicapped is much more optimistic and many behaviour modifiers have begun to deal with areas of prelinguistic competence, such as object permanence.

Assuming that we accept the cognitive position then the understanding gained from this framework should be hot news for a curriculum for the mentally handicapped child. In the next chapter I shall outline a prelinguistic, or sensory motor curriculum.

Yule and Berger(1975), working from the pragmatic point of view of the behaviour modifier very bravely and honestly try to grapple with ideas generated by the cognitive position, but encounter problems which arise from assumptions generated by an innappropriate underlying S-R model of the learning process.

I am suggesting that the process of teaching is inextricably tied to and functionally related to the material taught, and this implies that the learning process, even when considered abstractly, cannot be divorced from the content of what is being taught and the overall structure provided by the curriculum.

The ancient Greek philosopher, Heraclitus saw everything as change and process, and maintained that stability and permanence was an illusion imposed upon reality by the human intellect. This view of reality has considerable currency in modern physics, whereby objects seen by the layman as simple and solid are understood by the physicist to be an expression of the dynamic interplay of complex fields of energy.

Adopting a Heraclitian view, a general principle seems to operate that everything at one level has content and structure, but viewed at a different level the static description can be understood as a dynamic process. The attempt to define the process of transposition of process to structure arises in most sciences, including psychology.

These points may seem very abstract and divorced from the problems of the mentally handicapped, but there is a strong implication that if one sets about to teach the mentally handicapped child in areas of infant competence such as language, then it is necessary to understand the nature of the curriculum and also to understand that what the child learns is inextricably tied with how he learns.

The nature of the interaction between mother and normal infant seems to be designed to "educate" the infant in a manner ideally suited to his needs. The notion of a curriculum is alien to most mothers. If one asked a mother,

"What aspect of language are you teaching your child today?" She would be unable to answer and probably regard the question as

strange. Indeed, as we shall see shortly, when a mother does see herself in a didactic role, then the infant's language acquisition is likely to be impaired. Despite the unconscious and intuitive manner that mothers go about the business of mothering, babies tend to follow a similar course of development. Even so, there is some variation, and it would seem from K. Nelson's (1973) study of early language acquisition that there are several ways in which the child can acquire language. The path taken by a particular child seems to reflect both his and his mother's style of relating to the world.

Structure and Strategy in Learning to Talk

Some of the issues I have raised are well illustrated by Nelson's study. In it she looked closely at a group of 20 children during the period that they acquired their first 50 words. Her subjects all came from an American university campus and all had superior developmental quotients (mean D.Q.=120). In her study she focussed on what went on between mother and child and characterised the language acquisition process as a negotiation between the two.

She found, for instance, that the active participation of the child in family activities was important to the acquisition process. Children who went on frequent outings fared far better than those in T.V. orientated families, despite television providing a wealth of illustrated language.

The words that children in her sample tended to acquire, referred either to interesting objects, especially animals, or to

objects that the child himself acted upon. For instance, articles of clothing that children of that age could manage themselves, such as shoes, socks, featured prominently in the child's vocabulary, whereas the word "diaper" was conspicuously absent, despite the likelihood, that of all the articles of clothing named, "diaper" is likely to have a very high frequency of usage.

Nelson classified her mother/child pairs in these 3 ways.

- a) Whether mother and child agreed or not about how to categorise the world. For instance, Mother might see the grand piano and the kitchen table as being utterly different classes of object, whereas her child might see them both as flat surfaces with which to go "brrrm brrrm" with a toy car.
- b) Whether Mother was didactic and tended to correct what her child was saying, or whether mother operated by trying to understand the message that her child was trying to communicate.
- c) Whether language development was in terms of vocabulary growth, or in terms of increased syntactic complexity.

This latter dimension related to the child's interests and seemed to be sex linked. Object orientation, typical of boys, resulted in the development of vocabulary. Social orientation, doll play, role playing etc. tended to result in development in syntactic complexity. A third group of children tended to orientate themselves more to activities. The relationship between these and the form of their language development was not clear.

Nelson found that where mother and child agreed about partitioning the world and where mother attended to what the child was trying to communicate, then language was likely to be precocious, but where there was disagreement about the world, and mother played a didactic role, then the child's language would be retarded despite his intelligence. (See fig 5.1)

CONSENSUS MEANING		Language Precocious
DIFFERENT MEANING	Language Retarded	
	DIDACTIC	ENABLING

Fig 5.1 Nelson's categorisation of mother toddler speech.

She gives an account of a boy in the latter category. An early word that he began to use was CAR, this being used for cars, trucks, lorries, etc. Mother seemed happy with this usage, but when he also acquired the word TRUCK which he applied to trucks, lorries, tractors, buses, etc. she would correct him. From the boy's point of view it seems that he was attending to the size of wheeled vehicles and had formulated the hypothesis that big vehicles were called trucks, as opposed to small vehicles which were called, cars. However, he received so many disconfirmations to his hypothesis that he eventually discarded the word and regressed to his first use of the word CAR.

We can speculate from Nelson's example on what might have happened had the mother been more accepting. Plausibly, mother

would have accepted the "car-truck" dichotomy as labeling the sizes of wheeled vehicles. Having worked through this theory, the child might then have begun to attend to those exemplars of large vehicles that carried people, and needing a label for these, would have acquired the word "bus". Later he might attend to vehicles that worked on land, and so acquired the word "tractor".

It should be noted in passing that part of this process involves the notion of decentration introduced in chapters 2 and 3.

Let me briefly say here, that although the mothers' role in the acquisition process is that of enabling by confirming hypothesis, we shall see later that she also has the role of disconfirming and extending hypothesis. It seems that the skill of mothering entails managing these apparently contradictory roles in a manner that meets the developmental needs of her child.

With the insights provided by Nelson's study in mind, the following incident underlines some of the problems of an over rigid task orientated regime for the mentally handicapped child.

A teacher in a community school for the mentally handicapped was conducting a language class with a group of children using the Peamundy Language Development Kit. On the table was a box of plastic fruit. One child became very excited and began to repeatedly utter the word "apple" whilst reaching for a plastic orange. Her teacher immediately corrected her, saying,

"It's not an apple it's an orange"

Whereupon the child was reduced to a crestfallen silence.

It would seem, in the Nelson study, that a "curriculum" exists in the emergence of additional dimensions being attended to, but the "curriculum" is not invariant. A rural child would possibly have acquired the word "tractor" before the urban child. The developmental curriculum is not the child's private internal program but has some relationship with his experience.

The adoption of an idealist position on the mentally handicapped child emphasises the need to be clear about the relationship between structure and process. Furthermore, in order to realise an idealist position we must recognise our ignorance about the nature of the developmental process in the mentally handicapped child. We need some framework that will guide our endeavours so that we do not get lost. This will be the task of the next chapter.

CHAPTER 6

Integration and Differentiation from a System Perspective

In the account of Sadie, the echolalic child we typified her problem as an inability to either perceive or construct a relationship between her vocal competence and her understanding of the world. For Sadie, "words" and "things" did not fit together, but by using her play, we succeeded in some small measure in drawing her attention to the relationship.

In a less pedantic manner than that employed in the previous chapter we can typify our therapeutic endeavour as making possible the integration of two hitherto isolated systems which we might label the **vocal** and the **semantic**.

We also described a crawling child in similar terms. He has available a locomotor system and a system for exploring objects, but, as with Sadie, he cannot at a given time in his development perceive or construct a relationship between the two systems. When, eventually, he does integrate the two systems then he has a new superordinate system for dealing with objects located in large spaces.

In contrast, a babies' mouth/throat has a multiplicity of functions; eating, crying, mouthing, etc.; and initially the whole complex of mouth functions operates as one system, but with the development of vocalisation a differentiation of the mouth/throat into two separate sub-systems can be perceived.

Similarly, a differentiation of systems can be perceived

in the area of hearing. At one point in his development the infant does not seem to be aware that his own sounds are different from those uttered by the adult, especially since adults are in the habit of imitating infant noises (Pawlby, 1977). At a later point in his development though he will distinguish between two systems of sounds. The first involves his own sounds and those addressed to him by adults, whilst the second involves adult to adult speech which is beyond his understanding. Understanding here entails not the semantic meaning of the adult utterance but having models that make the phonemic sequences that adults produce predictable and repeatable.

He may initially not attend to adult speech but as his understanding of speech sounds develops he will begin to attend to overheard conversations and attend, not to the individual syllables of the speech, but to the parasodic overlays of adult speech. i.e. the intonations used by adults. He may play with the pattern of intonations, quite often accompanied by the appropriate gestures etc. Here the differentiation of systems employs different processes from those employed in the mouth example.

In the differentiation of the mouth we have a separation of a system of competence into two subsystems appropriate to a particular context. The differentiation between adult speech and infant speech entails the recognition of the possibility of competence in a sub system of what was previously beyond the infant's competence. This then is a differentiation by selection,

recognising that a system is knowable against a background of uncomprehended relationships.

We can now utilise the notion of integration, differentiation and selection to give us an overview of sensory motor development. The overview is summarised in fig 5.8 and the following section is intended to explain the diagram. It should be stressed that the overview is a framework for making sense of the interrelationships between various aspects of sensori-motor development leading up to the acquisition of language, rather than anything more definitive.

The Sensori Motor Field

We will begin by making the assumption that the infant experiences himself not as an integrated whole, but as different systems of sensory experience and actions. We can represent this state of affairs as fig 6.1.



Fig. 6.1 The infant represented as a set of separate action/experience systems.

Early on in his development the infant becomes aware that there is a relationship between the actions of his hand, which he experiences as kinaesthetic sensation, and the spectacle of his hands moving in his field of view. Here we have an integration.

Likewise the infant becomes aware that there is a correlation between activities focused in his mouth/throat system and events experienced in his hearing system.

The infant also learns to use the muscles of his face to smile and to elicit repeatable spectacles in the form of his mothers' response.

We can update this state of affairs from that shown in fig 6.1 to that given in fig.6.2

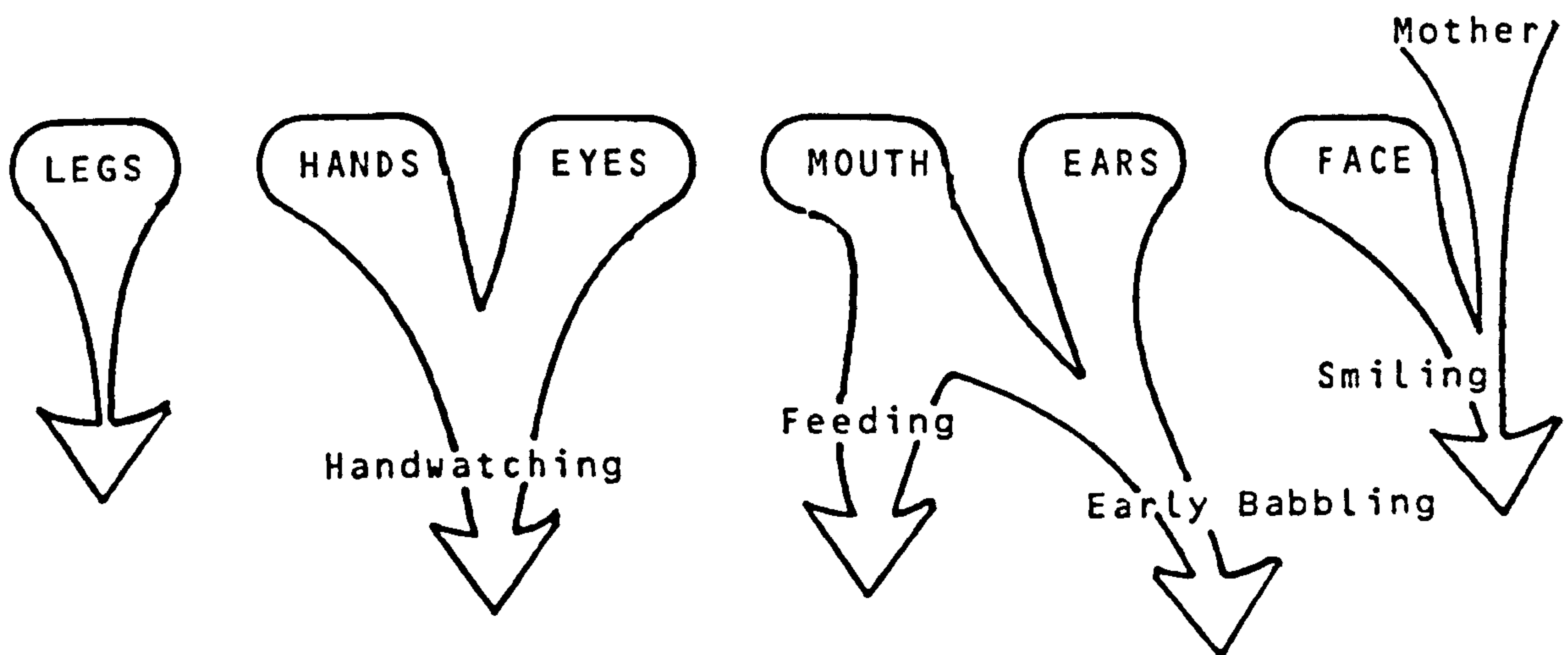

Fig 6.2 The emergence of handwatching and babbling

If we consider the elicitation of parental responses we can see that the picture is far more complex than is represented here, since the process of eliciting repeatable actions from mother involves both seeing her face, so the visual system is involved, and also eliciting cooing behaviour from her which of course involves hearing.

It also seems that there may be underlying maturational

processes. Lennenberg (1967) suggests that the emergence of smiling is maturational since it appears that smiling emerges at a fixed period of time after conception. Premature babies will smile at a later chronological age than full term babies but at the same conceptual age. (See Fig 6.3)

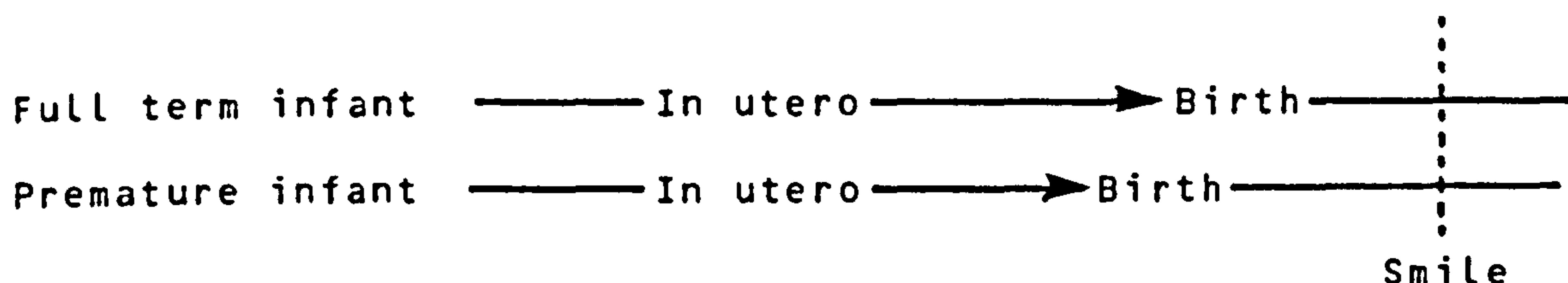

Fig 6.3 The first smile as a function of conceptual age.

There is some debate over this issue but for our purposes we can entertain the possibility that such maturational processes occur in many areas of infant competence.

Accepting the possibility that such processes occur does not imply acceptance of a naturalist position. In the case of smiling it may be that the infant has the opportunity to learn to smile, but if he fails then maturational smiling helps to ensure the inception of the baby into the social play of his family.

Issues of greater subtlety are encountered in the development of babbling. During early babbling particular sequences tend to occur.

In the case of consonant development, the infant begins by being restricted to back consonants such as 'K' and 'G'. But as his babbling develops his repertoire increases to include new consonant sounds by increasingly using the frontal areas of the

mouth. This gives us a sequence, 'K, G, O, L, D, V, M, B.'

In the case of vowels the converse appears to happen, although there is some debate here. Some authors { see Gluck-berg & Danks (1975)} maintain that initial vowel sounds are produced in the front of the mouth but the repertoire develops to include back sounds.. this would give us a sequence, "ee, uh, ah, eh." (See fig 6.4)

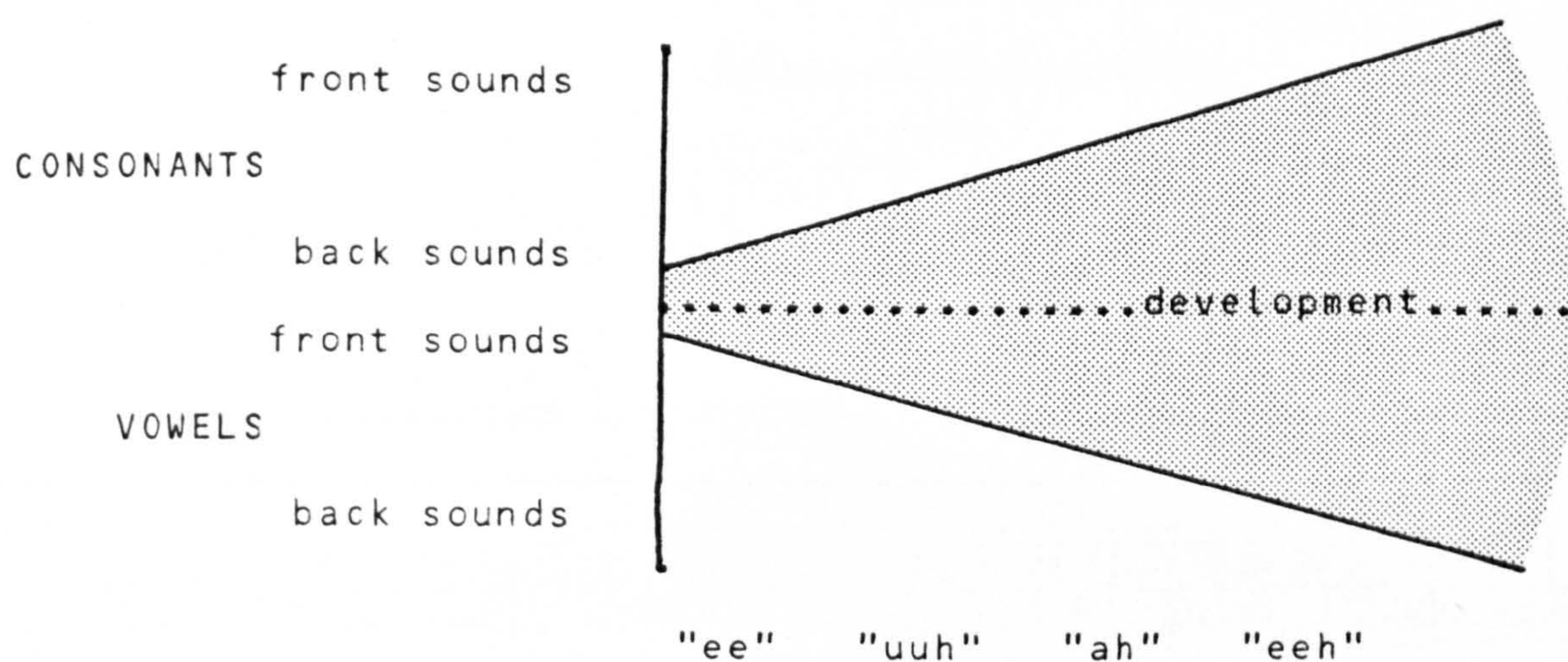

Fig 6.4 The development of vocal repertoire.

Here again the possibility arises that there is a maturational process underlying the sequence since it is reported that deaf children invariably pass through a normal babbling period (Oleron, 1953). However, whatever the nature of the process underlying the sequence, the existence of such a "one bit at a time" acquisition of phonetic responses does seem to have important consequences.

Initially the child will be attending to his own sounds

before beginning to attend to those sounds created by his parents. If we adopt a motor theory of speech perception (Liberman et al., 1967) whereby it is assumed that the child attends to and organises those sounds in his environment which have a relationship to his own productions, then were the child to have a large initial repertoire he would be faced with unravelling a complex range of sound patterns. The existence of some process which would introduce the infant slowly to his repertoire makes life much simpler for him in that initially the process decides for him what to attend to and organise.

Returning to our much simplified framework, we can represent such a process as a simple integration of subsets of adult speech into the infants' sound reception/production system.

The infants' exploration of objects is initially oral but with the development of hand-eye coordination, the hands become a means of bringing objects to the mouth until a point is reached where the hand-eye system itself becomes a means for exploring objects.

These developments, and the development through crawling of the child's conception of himself operating in large space is represented in fig 6.5.

With the realisation, mentioned earlier, that crawling is a means of attaining desired objects, the infant has a large system dealing with what might be termed object/spatial competence. Within this system there is continual restructuring and

development.

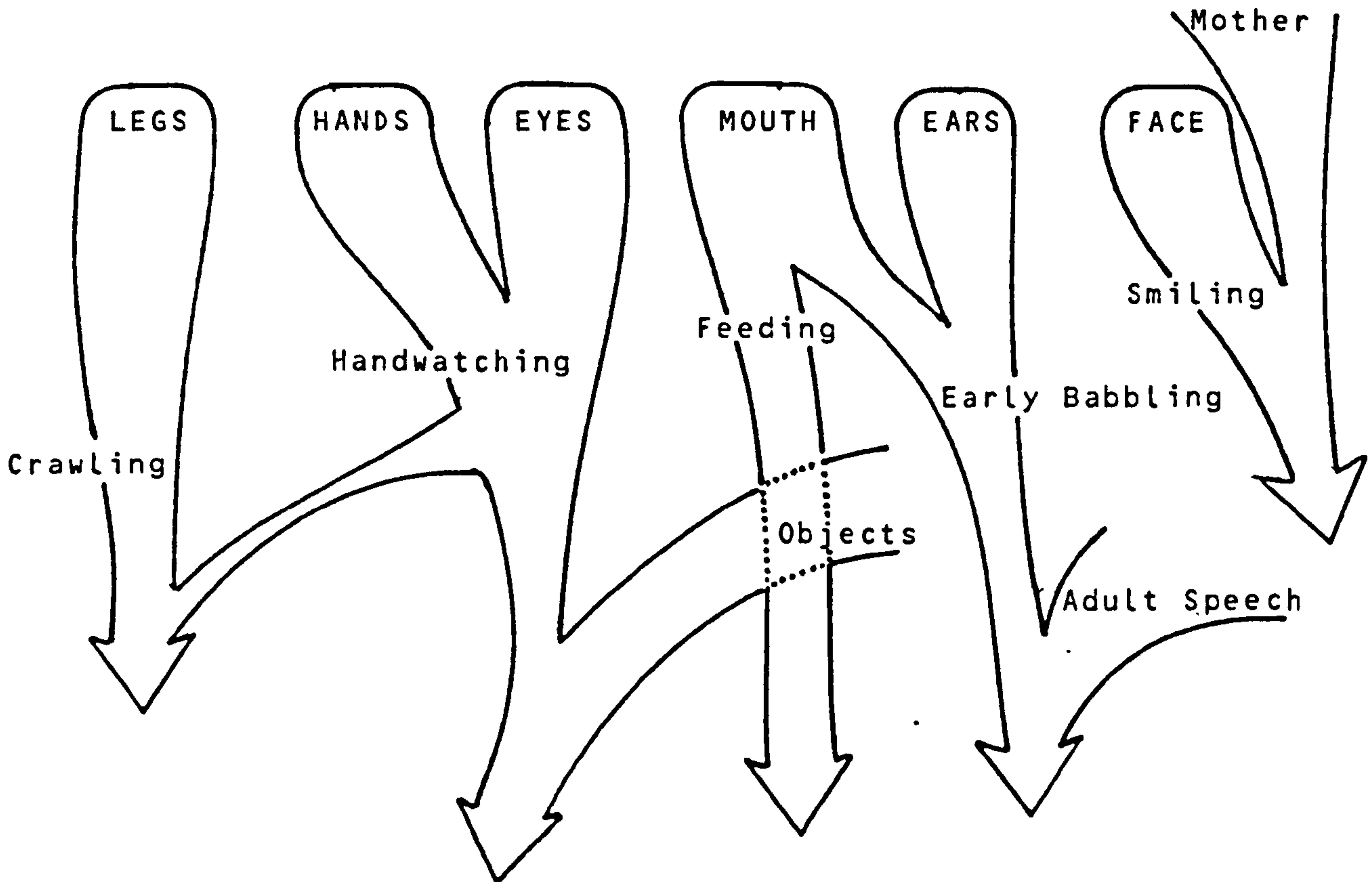

Fig 6.5 Further development of the infants' systems

An important development is that of tool use, whereby an object is employed as a means of acquiring a given end, rather than as an end in itself. The classical demonstration of this is phenomenon is that of Kohler's ape who used a stick to gain a banana just out of his reach. (Kohler, 1925).

In the Piagetian account of sensory motor development, this development heralds the fifth stage of development. The use of an object as a means rather than as an end has very important consequences.

Consider a thirsty toddler wanting a drink. His drink is in a high cupboard and out of his reach. He goes to Mum tugging at her and directing her attention to the desired object by pointing or looking at it. Mother obliges by interpreting her child's message and performing the appropriate action.

In this scenario, Mother is structurally equivalent to the stick used to gain the banana, and is simply a means used by the child to gain his particular end, but in using mother as a means the toddler has had to communicate his intentions. Throughout his life the child has, in a sense, communicated, but the action described here is different since he needs to plan his communicative act before he deliberately operates his scheme.

In our systemic framework we have an integration of the social/interactive system with that of object/spatial competence. Within this system the operation of greater sophistication in the use of gesture promotes the further development of the social and object/spatial fields.

Throughout the development of these systems the child becomes increasingly sophisticated in the means in which he uses his mind's eye and he becomes a sophisticated manipulator of images. For example, he can visualise himself operating a plan, and foresee problems before he puts the plan into concrete operation. (The example of a blocked cupboard door is already given on page 88).

In chapter 3 , the idea was presented that images could be addressed by actions. The use of such addressing devices gives

the child greater freedom and flexibility in dealing with the here and now. Indeed it may be said that the child is released from the constraints of reality. The use of symbols represents a further step in the development of distance from reality, but in order to successfully use these, the child needs the flexibility afforded by a sophistication in his use of mental imagery. A closer look at the development of object permanence is presented in the interpretation of the Uzgiris and Hunt scales presented in appendix 1. For our present purposes we may consider that we have here a system dealing with social/object/spatial competence developing to the point that it becomes possible for the child to support a symbolic system. The symbolic system is available in the language of the parents and the child has already developed a competence in some aspects of this system during the development of babbling. The final integration then is the integration of the phonemic system with the social/object/spatial system. The development of the total system is represented in fig 6.6.*

The following account of how this might happen is appealing but probably simplistic.

In our account of the course of babbling we have the child's repertoire of sounds increasing until he finally acquires front consonants (b,d,n,m) and back vowels (a). Babbled combinations of these sounds result in utterances such as (mama, dada, nana, baba, papa) which are usually recognised as the infant's first

* The schematisation is my simplification and integration of Piaget's account of sensori-motor development, with a few elaborations. The scematization was promoted by the insight that the echolalic child maintained a boundary between speech and his sensori-motor semantic system.

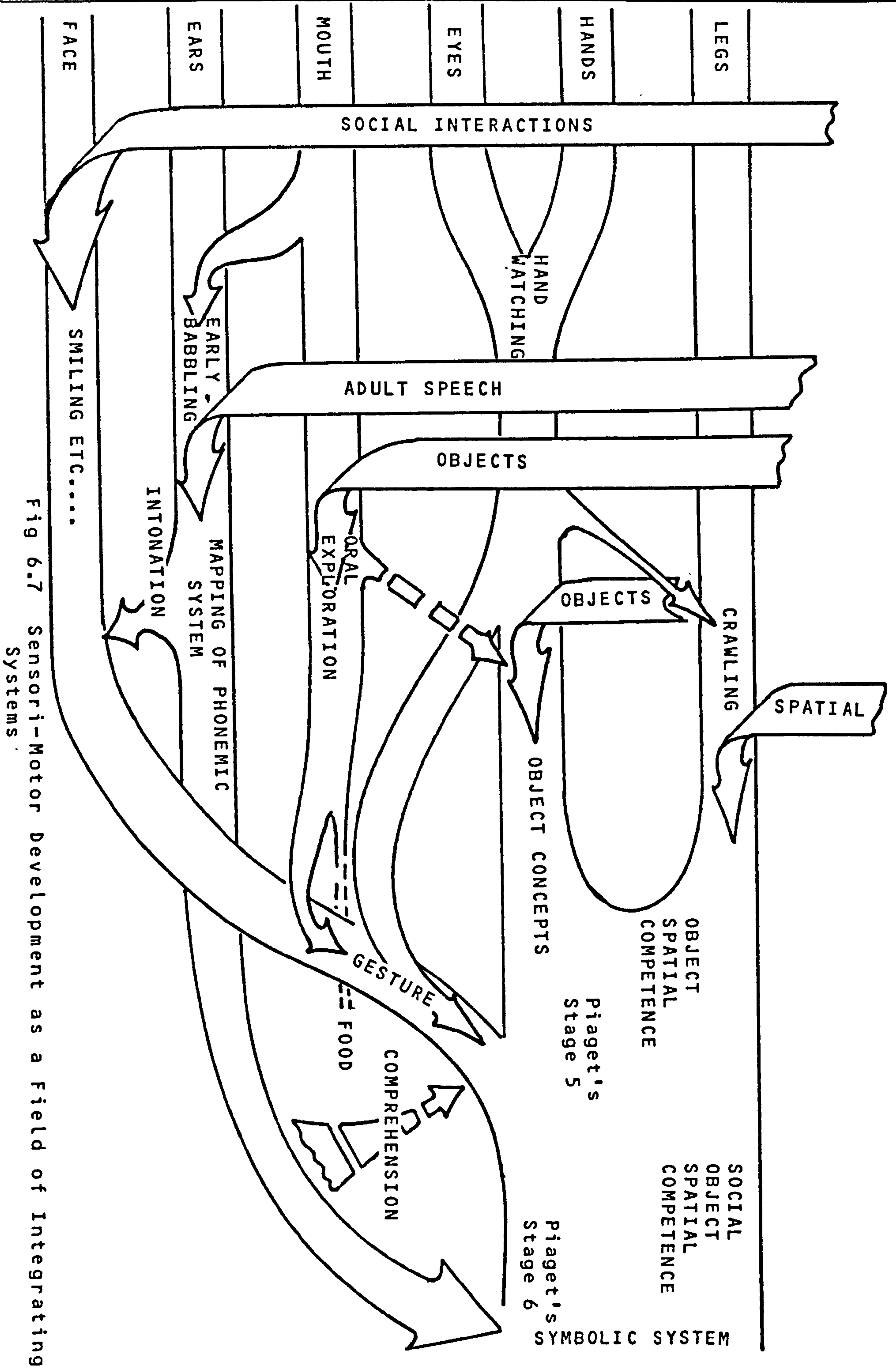

Fig 6.7 Sensori-Motor Development as a Field of Integrating Systems

words. As far as I know these forms are to be found universally regardless of the infant's mother tongue. (see also Ferguson, 1964)

Baby's first words are part of his parent's culture so his production of 'mama' or 'dada' is anticipated with keen relish. When baby does produce the magic words (usually, to mothers chagrin, it seems to be 'dada') parents respond with the same enthusiasm as they did to his smile many months previously.

It is very tempting to suggest that this happens at the same time as the toddler is ready to support a symbolic system. Such a coincidence would have a nice design logic, but it does seem to happen earlier.

It seems that the infant, throughout the development of his systemic integration goes through two levels of process.

- a) The awareness that two systems are somehow related without necessarily knowing how.
- b) The development of understanding how they are related.

It may be the case that the emergence of utterances such as "mama", serve to draw the toddler's attention to the possibility that the two systems are interrelated. Indeed it is invariably the case that in language acquisition the child's comprehension develops ahead of his productive competence. As McNamarra (1972) pointed out, the child needs to know what he is going to say before he attempts to say it.

We have already suggested the idea that echolalia is a failure to integrate two systems. This is rather a trite statement since it misses out the complexity of what integrating the two systems entails. In our account of Sadie we attempted a much richer explanation, but even here we only succeeded in presenting a plausible explanation about how the two systems might be integrated such that Sadie would be able to decenter and attend to elements from the two systems, thus allowing her to integrate the elements into novel aspects (words standing for things) which form the basis of a new system.

Some further insights into the subtleties of the process of system integration/differentiation may be gained from the following hypothesis about an experience which the reader may share.

In hearing an exotic foreign language, ones' experience is of hearing, not strange words, but a confused flowing gobbel-dygook. It seems that the gaps perceived between words do not exist in the physical sounds that come from the speakers mouth, but are put in by the listener.

This works with written as well as spoken language.

My own experience of acquiring some very limited modern Greek seems to follow the following course.

Following an initial period of hearing Greek as a continuous flow of strange sounds, I began to discern the occasional word, Presumably these words either occurred frequently or had some

phonemic similarity to english words. Endax..O.K. has frequent usage, and 'Aftos' sounds like 'after'. Having gained a few such words I was able to somehow discover a structure and suddenly I heard Greek as strings of words, without neccessarily knowing what the words meant.

It may be that in acquiring just a few words I had enough information with which to decode the rules operating the intonation contours of Greek. By recognising the portion of the intonation pattern that corresponded to the words I knew, I may then have looked for similar intonational sequences within other segments of speech. Having found these the corresponding sections of gobbeldygook emerged as words.

Despite the gross simplifcatins and omissions neccessary to produce a diagramatic summary of sensori-motor development it provides us with a useful framework for looking at some of the problems of the developmentally retarded child.

I have already, in the account of the synthesis of speech and meaning, partially introduced the notion of systemic synchrony whereby two systems are developing concurrently but independently and where the possibility of integrating the two systems entails that they are mutually ready for integration.

When we view the retarded child through this framework we often find that asynchrony of two systems contibutes to and compounds their problems.

For example, the normal adolescent can cope to a reasonable extent with the problems presented by puberty. The pubescent mentally handicapped child lacks the language, the selfawareness, the social maturity, etc., which would help him to cope.

Our systemic framework allows us to specify component subsystems which need to be at an appropriate developmental level before a given child can be expected to talk.

He needs...

- a)Cognitively, to be able to symbolise. (Piagetian stage 6)
- b)To have something to talk about.
- c)Be interested in people and want to communicate
- d)Have some understanding of how to communicate (stage 5)
- e)Have a sufficient mastery of speech sounds to be able to use this competence in language.

The low functioning autistic child often has (a), (b), and (e) but his asocial orientation precludes the possibility of communication. Until work is done with him in the area of social interaction attempts to promote language are likely to be premature unless the portion of language taught is explicitly directed at developing social competence.

Some mentally handicapped children appeared to have babbled at an earlier period in their life, but at a time when their corresponding interactive and cognitive systems were insufficiently developed to support the babbling. These children, instead of becoming echolalic, seem to lose interest in sounds and become mute, and functionally deaf. If eventually they do

acquire (a), (b), (c), and (d) they still lack the productive competence to talk. In the case of such children and also children who are not necessarily mute but whose phonemic competence is retarded, it is useful to focus on a non verbal communicative system such as a sign language in order to allow the development of communicative competence to proceed. At the same time work can potentially be done on the sound system.

The notion of developmental asynchrony highlights the vacuity of giving a mentally handicapped child an all embracing mental age. Even where there is no asynchrony there are considerable differences between a mentally handicapped child and a normal child of the same mental age. If they are compared in terms of cognitive structure then the mentally handicapped child will have operated that structure for many years, whereas his normal counterpart will operate that structure only briefly before moving on to other means of structuring his knowledge. Viewed thus the handicapped child knows more about his world than his normal counterpart.

Conversely, if a comparison is made on the basis of the content of the child's knowledge then we may find a mentally handicapped child to have a mental age of three, yet he cannot talk.

The notion of systemic integration and differentiation is particularly useful in working with the profoundly handicapped child.

For example Arnold is 14 years old. On developmental tests he scores at the level of only a few weeks. He is microcephalic and severely spastic. Without regular physiotherapy, his arms tend to bend tightly at the elbows and to be tucked in against his chest. His hands bend tightly at the wrist and there is little freedom of movement. He is apparently deaf.

I attempted to work with him in order to develop the possibility of some voluntary motion but found no clear cut behaviour to respond to. I also undertook to exercise his arms in order to relax his muscles, but any gross behaviour engaged in only served to increase the spasm.

Eventually I employed a stethoscope to monitor his heart beat as an indicator of whether he was responding and attending to my activities or not. Tickling etc., produced no obvious effect on heart beat. I had observed that on occasions he would scratch the back of his neck. When I replicated his actions there was a dramatic increase in heart rate.

This effect could be repeated several times. By alternatively scratching the back of his neck and then tickling under his arms it was eventually possible to gain a heart rate response by tickling alone. Further activities involved a counted finger walk prior to tickling (i.e. one, two, three, tickle!) Eventually Arnold would produce an anticipatory tensing of his body when counting was used without finger walking. The rhythmical sound of counting was sufficient data for anticipation of the tickle.

This procedure, quite explicitly, used the notions of integration and a variety of differentiation to extend the range of events that Arnold attended to (see fig 6.7). Differentiation here seems to differ from that described in chapter 4 inasmuch as the original addressing feature disappears, leaving the secondary disambigating feature alone. We shall examine this notion further in chapters 8 & 9.

- (1) [Neck scratch]
- (2) [Neck scratch] + [Tickle]
- (3) [Neck Scratch] OR [Tickle]
- (4) [Neck Scratch] OR [Counting] + [Finger Walk] + [Tickle]
- (5) [Neck Scratch] OR [Counting] OR [Finger Walk] + [Tickle]

Fig 6.7 Sequence of phenomena available to Arnold's attention.

Formal Assessment

The systems framework so far provided might potentially be used to provide a careful assesment of an individual child. Fortunately a ready made scale is available in the Uzgiris and Hunt (1975) scale which can be related to our system overview. In the next chapter a modified presentation of the scale is introduced.

Appendix 1 comprises a self contained manual for the educational and clinical administration of the Uzgiris and Hunt Scales. The items in the scale replicate those of Uzgiris and Hunt (1975) and in this form only four of the six scales are employed. The manual presented here differs from that of Uzgiris and Hunt only in its form of presentation and for a fuller understanding of the scale the reader is referred to the original. Although the scales are designed as an assessment instrument my motivation for presenting them in this form is that they provide a useful "Piagetian Primer", although it departs from Piagetian theory in some points of detail.

The practical implication of my motives is that the Uzgiris and Hunt scales could be used as a curriculum for some, but not all areas of the child's competence. As a curriculum, though, it should not be in the form of a rigid programme of operations to be applied to specific materials, but as a set of guiding principles enabling the teacher to understand how the child understands his world and so enable her to respond accordingly.

To suggest that an assessment scale could be used as a curriculum may strike some as being an ill-conceived notion since it smells of "teaching to pass exams", or even training to take I.Q. tests. To teach someone to pass items on standardised developmental tests such as the Griffiths (1954) or Bayley (1965) would indeed be silly.

So what makes such practice based on the Uzgiris and Hunt scales legitimate? Let's look at the principles underlying the construction of standardised developmental tests.

We have a group of, 100 children, and we observe and count every three months how many have acquired the skill of, say, blowing bubble gum. We then plot a graph showing how many children have acquired the skill for each three month interval and obtain fig 7.1. From this, we can say that the average child in our sample learns how to blow bubble gum at six years of age. Using the same procedure, we discover that 4 years and three months is the average age at which children in our sample can hop on one leg in wellington boots.

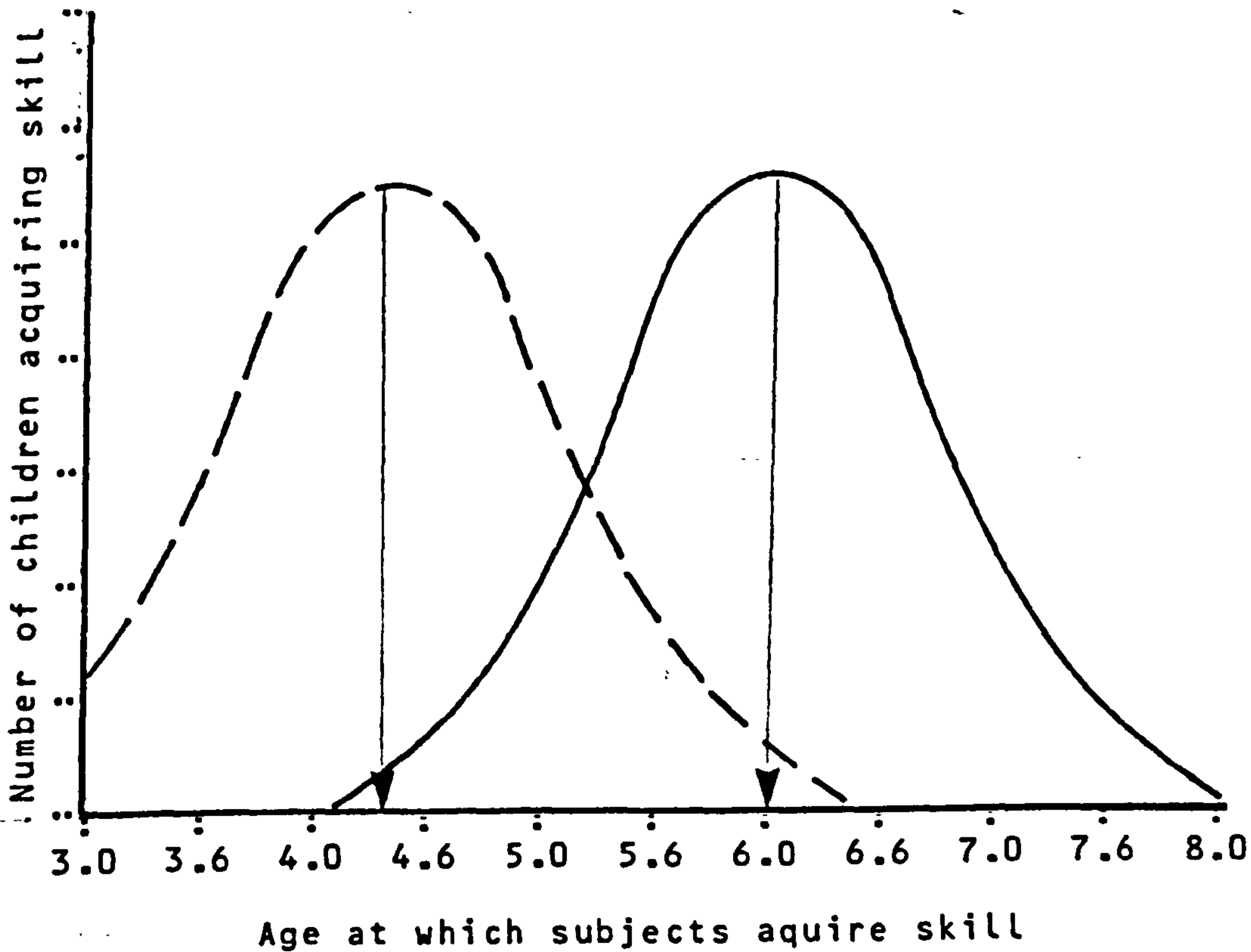

Fig 7.1 Hypothetical plot of bubble gum blowing acquisition age

Intuitively, we can obtain and test out a series of skills which the average child in our sample acquires, say, every month. If we can assume that our hundred children are representative of the child population of the country, then we have a tool for measuring any child's developmental level. We have, in effect, a ruler where each mark on the ruler is a test item. (see fig 7.2)

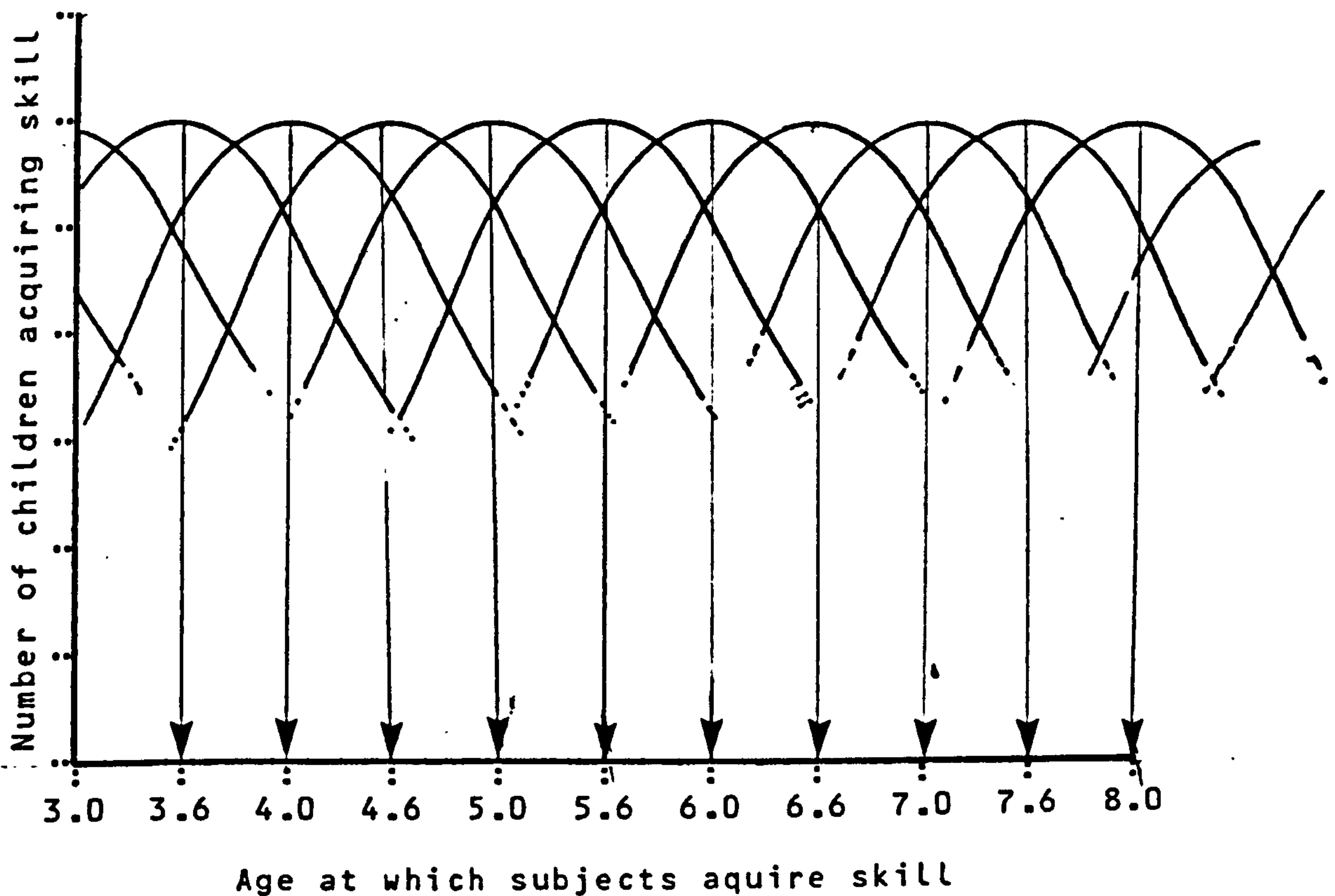

Fig 7.2 Hypothetical superimposition of skill acquisition ages.

In practice there is much more to it than this. Test items would be selected that have low variance. (i.e. the graph would have a small spread. It would also be necessary to make sure that the items are administered in exactly the same way for each child. Our original sample of children would have to be

representative of the population as a whole so that they could be drawn from a variety of backgrounds in the same proportions as the population as a whole. Additionally most developmental scales are subdivided into subscales and the pattern of scores across those scales give valuable clinical information.

Now although a child's developmental age may be useful for monitoring his progress in other areas, each individual item, excepting statistical criteria, is arbitrary. "Blowing bubble gum" could be substituted by "being able to tie shoelaces" as long as the average child in the sample acquires the skill at the right age. There is no theory underlying the test to justify the selection of any specific item.

If we had a theory of development, then our selection of items for a developmental scale would be determined by the logic of the theory rather than by statistical criteria. How "good" the scale would be would depend on how "good" the theory is.

The "goodness" of a theory is problematic and I shall avoid an exhaustive discussion of the topic here but restrict myself to expressing three criteria of "goodness".

- (i) Does the theory fit observable facts?
- (ii) Is the explanation provided by the theory useful for what you want to do with it?
- (iii) Is the theory coherent? Are there any contradictions and omissions in the logic of the theory?

Given our current state of knowledge, Piaget promises to reasonably fulfill these criteria. Up to a point, Uzgiris and

Hunt have taken Piaget's theory applied to the sensori-motor period, the first 18 months, as a basis for constructing their scale. So, each item on the scale demonstrates the underlying means of knowing employed by the child, according to Piagetian theory. Furthermore, the means of knowing demonstrated by one item is a necessary pre-requisite of the means of knowing demonstrated by the next item. This statement may be more clearly represented in fig 7.3

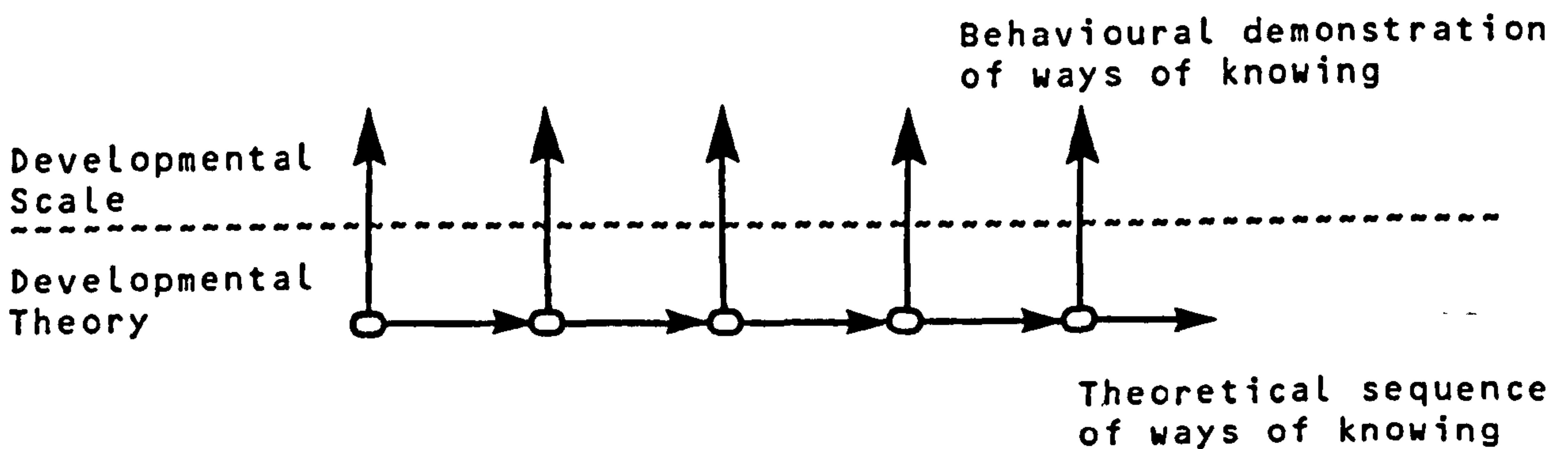

Fig 7.3 Developmental process underlying test items

In practice, Uzigris and Hunt have departed slightly from the Piagetian stages and have inserted extra "stages" which seem intuitive rather than theoretical, though of course their intuitions have been refined and supported by empirical evidence obtained by testing out the stages. It seems, by and large, that what each of these extra scales demonstrates is the child's growth in competence in operating within a particular Piagetian stage. So, the Uzigris and Hunt scales zig-zag across the

Piagetian stages. (see fig 7.4)

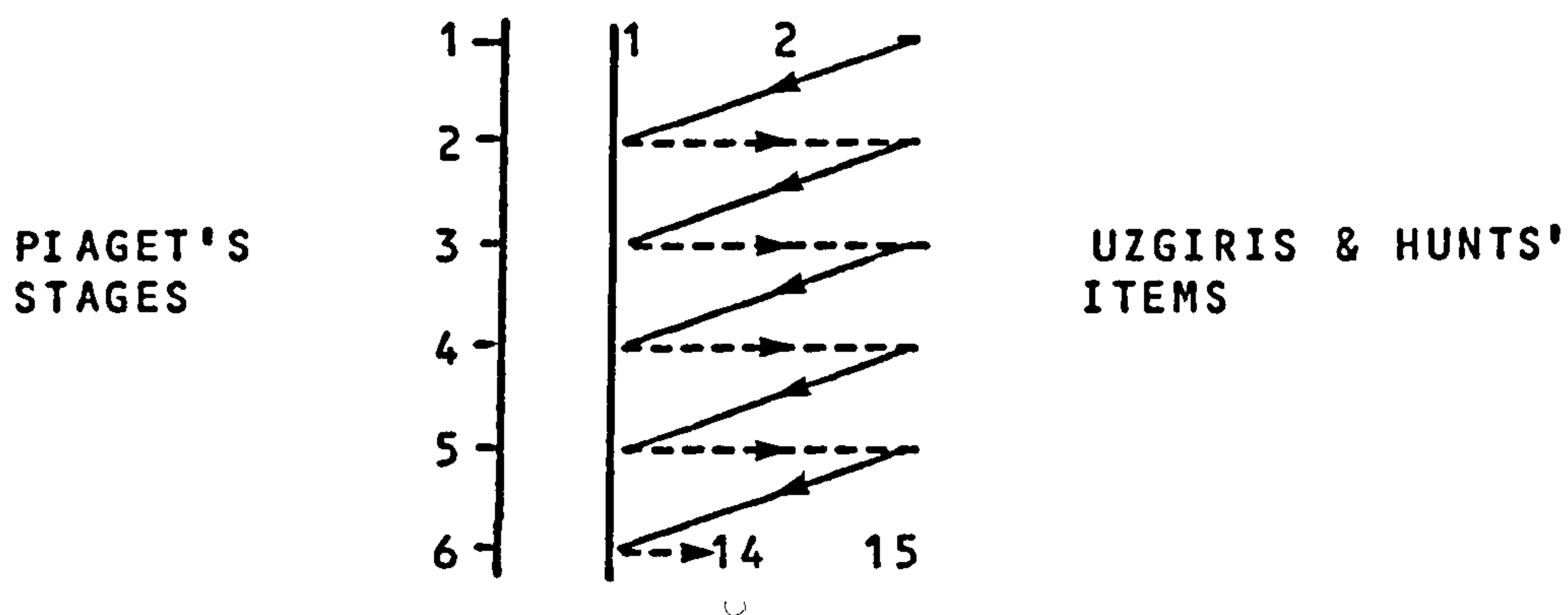

Fig 7.4 The relationship between Piaget's and Uzgiris & Hunt's stages

Uzgiris and Hunt seem to assume that each item in their scale represents a discrete stage. I think it is more plausible that the horizontal components of the zig-zag lie along a continuum, though this is not always so clear.

Thus, the movement from item 1 to item 2 in the object permanence scale (see text of scale : Appendix 1) represents an increase in the child's confidence in maintaining an object in the field of view by looking at it during it's path of movement. Eventually this confidence will arrive to such a level that he will persist in trying to make the object reappear by looking at it. So, his understanding of objects in this context changes from "objects disappear because it is in the nature of objects to disappear", to "objects disappear because I can't make them reappear". (i.e. because the operation of looking fails to make

them reappear). So, at one level, we have a continuous process involving the increase of confidence but which is manifest at a different level as a discrete change.

These considerations apart, the Uzgiris and Hunt scales seem a useful way of getting people to try on Piagetian spectacles to look at retarded children. Thus, the relationship in fig 7.3 between the developmental theory and the developmental scale changes direction. When a child reaches his ceiling on the scales, we should then ask, "What does this tell us about how the child makes sense of the world?"

For this reason I have attempted to provide an explanation of what each item demonstrates. The explanations I provide are provisional and the user is advised that there currently is considerable controversy (see Butterworth 1979) about what it is that the child attends to and understands during his acquisition of object permanence. With regard to the other areas of the child's understanding, there is little controversy because, as yet, little work has been done outside the area of object permanence. This partially reflects the importance of object permanence but, more likely, it is because the study of object permanence seems more amenable to controlled experimental work than, say, gestural imitation.

The diagnostic use of the Uzgiris and Hunt scales

Considerable clinical information may be obtained from any psychometric tool consisting of subscales measuring different abilities by judgement based on the profiles (the patterns of

differences in abilities). For instance many clinicians maintain that a depressed score on the Similarities subtest of the Wechsler Adult Intelligence scale is indicative of Schizophrenia.

The theoretical underpinning to the Uzgiris and Hunt scales potentially lends itself well to clinical formulations based on the logic of the theory.

The following comments are based on my relatively limited experience in employing the object permanence, the means end, the gestural imitation, and the vocal imitation scales in attempts to answer the question, "Why does this child not talk?" Support for some of the propositions made here is provided by Bates (1976)

(1) Language involves, amongst other things, the use of symbolic representation. Before he can begin to use symbols, the child must have a representational sophistication at least at the level demonstrated by item 11 on the object permanence scale. (Piaget's stage 6).

(2) If a child is not talking or comprehending much and has passed beyond item 11 on the object permanence scale then we can learn something from the means end and the imitation scales.

(3) If the child fails to pass item 10 on the means/end scale (Piaget's stage 5) then he will be unable to use adults as a planned means to obtain an end. This level is necessary if the child is to communicate in a

deliberate manner. A score on this scale which is depressed in comparison with the object permanence scale often seems to indicate a child who is unduly passive in his relationship with the world.

(4) The child who obtains a depressed score on the imitation scales will probably exhibit one of the following characteristics.....

(a) Not interested in people. (since imitational competence derives from social interaction)>

(b) Has a poor body image (Hypothetically a disorder of kinaesthesia).

(c) Has problems of motor coordination.

Where a child falls into this pattern but is obviously sociable then disorders of kinaesthesia and/or motor coordination are suggested.

(5) Where a child has a depressed score in vocal imitation alone then some disorder of auditory input may be indicated. This may be straight forward deafness or a specific high frequency loss, or conceivably and hypothetically a coding-decoding problem. Dysarthric disorders may be reflected. These may again be a function of disorders of motor coordination but even a relatively minor disorder, which would not reflect in performance on the grosser behaviors employed in the gestural imitation scale, would give rise to articulation problems.

The suggestions made here have the status of working clinical hypothesis based largely on clinical impressions. Accordingly a great deal of systematic work could be done in this area. Dunst (1980) provides a useful systematic development of the differential uses of the Uzgiris and Hunt scales to which the interested reader is referred.

The Uzgiris and Hunt scales as a curriculum

In viewing these scales as a curriculum, certain misconceptions about the nature of the child's knowledge may reduce their usefulness. These possible misconceptions might best be dissipated by examination of Piaget's concept of horizontal décalage.

Intuitively the concept is demonstrated in the observation that potters' children acquire conservation of volume in clay long before other children. The rule structures that the child operates at each stage are not empty processes that he can apply to any class of object. They are derived directly from the child's experience with that material. A child who passes item 10 on the object permanence scale when an object is concealed in the hand before being hidden behind a screen, will not necessarily pass the same item if it is concealed under a cup and then passed behind the screen. The child has had more experience of objects concealed in adult hands than he has beneath cups. Objects concealed under towels represent an easier task for children than objects concealed behind screens.

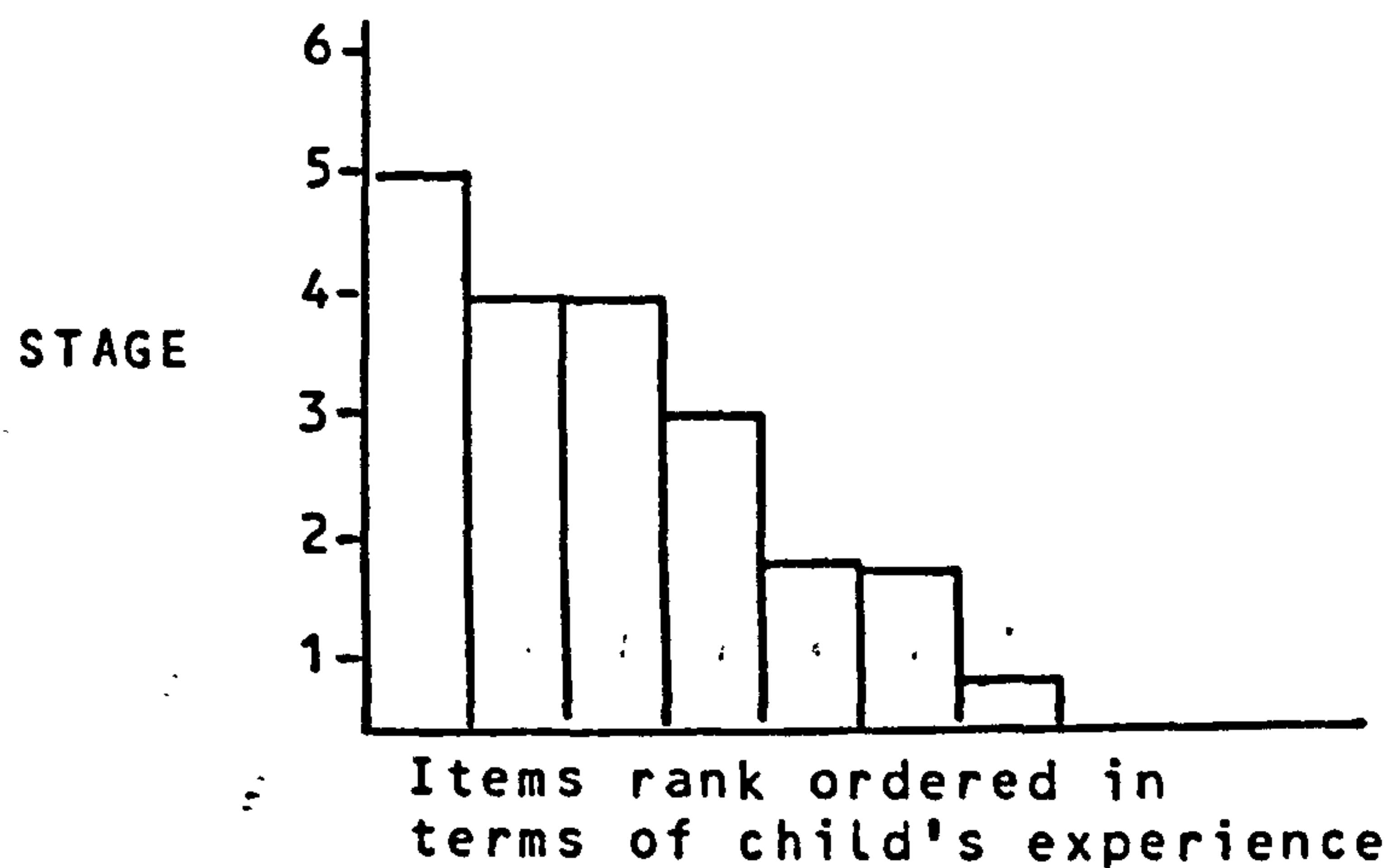

Fig 7.5 Hypothetical relationship between experience and cognitive level

Horizontal décalage would be manifest as the attainment of the same cognitive structures in different material situations, not necessarily at the same time. Fig 7.5 illustrates the notion that if items are ranked ordered in terms of the child's experience, then the ordering will correlate with the different cognitive stages obtained for each item.

We could presumably test the hypothesis by somehow measuring the experience a particular child has with each object and then, having tested each item on the scale, work out the correlation which should approach 1.0. For the teacher, it would be appropriate to accept the hypothesis and use it as an indicator of the child's experience, although, as an important rider, it is probably true that the child's own interest is also indicated.

The main point is that, if the scale is to be used for part

of the curriculum, then it needs to be applied in a flexible manner to a wide range of materials.

The teacher is also encouraged to invent variations and elaborations of the structures demonstrated by the scales. This is especially appropriate in the means/end scale. An example of this might be, fishing objects from off the table top with a rod, line, and large hook; placing a toy out of sight on the end of a long piece of string so that pulling the string brings the object back into sight; etc. It would also be good practice, when inventing such variations, to attempt to provide explanations of what the situation demands of the child. This would also help avoid presenting problems beyond the child's competence.

Although it may be necessary with some children, the use of sweets, biscuits, etc as goals should perhaps be best avoided. If the child is too intent on the goal then the possibility of decentering is reduced and so he will fail to attend to a range of attributes available in the situation.

Frequently, a change in the child's style of operating will be seen in these situations. Initially he is goal orientated. He works in order to get the object. After a while, as the task approaches his level of competence, he will regard the situation as a game and may even take his own initiative. The means becomes intrinsically interesting. The spirit of such a change is well illustrated in the following anecdote.

I was assessing James on the object permanence scale using

an orange as a desired object. Each time James found the orange, he took a bite. On approaching his level, James began to hide the orange himself. When finally he had taken the last piece of orange, in order to carry on with the game, he spat it out!

During this sticky melee, we found that James failed item 10: finding an object followed by one invisible displacement. By one demonstration in terms of his own action, (i.e. Placing his hand over the covering cup, prompting him to cover the orange, then pushing it behind the screen and leaving the orange there), James was subsequently able to do item 10. Several weeks later he was reassessed and found to have retained the new level.

Here ends part two. In part three we shall be returning to some of the ideas introduced in part one and developing them further to explore the role of success and failure in the developmental processes of the mentally handicapped child.

PART 3

MODELLING SUCCESS AND FAILURE

CHAPTER 8 ...Imitating a child

Recap

In section 1, ideas were presented about the possible nature of processes involved in organising the infant's knowledge about his world.

It was proposed that this knowledge was organised hierarchically, and that the two processes of integration and differentiation updated the hierarchical structures in the light of experience in interacting with the environment.

This system was described as operating either optimistically, whereby it tended to opt for an integrating process, or pessimistically, whereby it tended to unpack and if necessary differentiate. In this section we shall return to these notions and further explore the concepts of optimism and pessimism and their relationship to success and failure.

So far, the ideas presented have made little distinction between normal and mentally handicapped children. In this section the differences will be explored and an attempt made to develop a differential theory based on difference in cognitive risk taking styles.

We shall begin with an account of a therapeutic enterprise with a socially withdrawn mentally handicapped child and from this example we shall examine some ideas about the content of social relationships before pursuing the questions of optimism and pessimism.

Therapy with a severely withdrawn child.

Preface

I had, with the active help of his teacher, been assessing a child on the Uzgiris and Hunt object permanence scale described in chapter 7. Lenny, the child, is severely mentally handicapped and socially withdrawn. Following the session, Lenny's teacher and I were discussing his performance. On the table were two empty yogurt cartons. Lenny picked up one of the cartons between his two fingers and proceeded to wave the carton rapidly from side to side. This is one of his stereotypies and normally he would maintain this specific activity for a period of half an hour or more. Without any real rationale I picked up the other carton and copied his activity. He then began to tap his carton on the table, and again I copied this. Lenny responded to this with a great gasp and ran through his whole repertoire of actions with myself in hot imitative pursuit.

Most discussions of stereotypies assume that the child maintains the stereotypy as a defence against his world and the child engaged in such activity has succeeded in blanking off the world. Though the idea of such a defence is plausible, it is based on the notion that attention is a passive process operated by means of "filters" or similar processes. More recently, a new conception has emerged of attention as a process of selecting from the environment those aspects which are relevant to the current and ongoing interest of the subject. (Neisser, 1978) The subject, according to this conceptualisation is in an active relationship with his world. When we apply the notion of active

selection towards an explanation of stereotypy, we are allowing the possibility that the child thus engaged, may be aware of the world beyond the field of his ongoing activity but finds it irrelevant to his stereotypic activity. When I imitated Lenny, I provided something in the world that was relevant.

The Therapy

Shortly after this incident I was asked by a teacher if I could give her some ideas about what she might do with Judy, a child who was very similar to Lenny.

Judy could be briefly described as an attractive but socially passive 12 year old girl who would typically be seen walking barefoot, on tiptoes, gazing just above the horizon. Her usual activity involved systematically tearing long thin strips of paper from a sheet and then flicking the strip with her fingers. She persistently disrobed and had to be dressed in a cat suit. Especially characteristic was her apparent indifference to people, marked by her complete avoidance of eye contact.

With the episode with Lenny in mind, we approached the problem by trying to see the world as Judy might see it, and also on speculations about underlying processes of memory organisation.

A plausible hypothesis seemed that for Judy the world was full of potentially recognisable and familiar things but that she was unable to anticipate what was going to happen next. Underlying this, the implication seemed that in order to

recognise, she must search through her memory for the image of what might be familiar. Given a minimal degree of anticipatory organisation, the memory search represent no more than an inefficient rummage and Judy would be lucky if she found what she was looking for, let alone do something with it. (i.e. integrate it with a co-occurring or contingent familiar event) Since I assume that such integrations are the basis of anticipatory organisation, it seems that Judy is caught in a circular situation. However, there is an area where she does have the ability to anticipate, and that is her own idiosyncratic activities, viz, her stereotypies. Here she can act and produce a predictable result. The problem is that her stereotypy is a closed system and beyond the object employed in the activity, there is nothing in the world that is relevant and causally related to her stereotypy. So she cannot use her chosen actions to generate interactions with other potentially familiar items in the world. Here again she is caught in a circular situation. To break out of this circularity it is necessary to alter the nature of her world such that there is a simple causal link between her behaviours and those of her environment. This is what we do when we imitate a child's actions.

Let's describe the process from Judy's point of view. She is engaging in a stereotypy when she suddenly notices a direct relationship between the visual input of her stereotypy and part of the surrounding chaos. There are enough point of identity between her stereotypy and the adult's actions to make the relationship "obvious". She changes her actions and produces a

predictable change in the adult's actions. She discovers that she can use her own repertoire of idiosyncratic actions to develop a map of the adults' imitating actions. Now, were the adult's imitations a perfect match, then presumably Judy would use her whole repertoire of actions, reproduce the effects in the adult until a perfect mapping had been attained. This would be a new but closed system and change in structure would cease to develop. In practice though, the identity is not perfect since it is very difficult to produce a perfect imitation of an idiosyncratic and systematic stereotypy, and further, there are obvious contextual differences between the child's actions and those of the adult. It seems that this line of argument would predict that in attempting to map the imitated actions, she would also map the differences. Thus novel elements would be introduced into her system and she would move into a more open relationship with her world.

To put these ideas into practice, we decided to set up short sessions where an adult would imitate Judy. It was decided to limit these sessions to a duration of ten minutes. It seemed practical that a teacher with a class of eight very difficult children could reasonably devote this amount of time with an individual child. We also decided to give her a mark to indicate the termination of the session. This detail was based on a point raised by Bruner(1975). Bruner's argument, tailored to the present context, is as follows. Whilst the onset of these sessions would be obvious to Judy, the termination of the sessions would not be so obvious. Consequently, there seemed to

be a risk that if she attempted to map in an unresponsive context, the failure of these mapping attempts might be manifest within the sessions. Accordingly, marking the boundaries for the sessions defined for her a context where it was safe to attempt mapping.

Since, in the long run, we were interested in allowing Judy to maintain an open relationship with her world regardless of context, it seemed undesirable that the sessions be limited to the same adult. Three adults undertook to see Judy daily.

The initial sessions were set up with the adult and Judy being seated facing each other. Alongside the adult and facing Judy was a large mirror. The adults initially imitated Judy by mirroring her activity. So Judy's right hand activities would be imitated by the adult's left hand, etc. The mirror served to emphasise the nature of the activity.

The initial results were dramatic. Within a few sessions there was prolonged eye contact. The adults involved described the experience as a "clicking together", .."of suddenly being of relevance to Judy". She also began to initiate cuddles. For one session we introduced a stranger as therapist, within minutes, by imitating Judy she too experienced the rapport.

At this point let me make two comments.

a) At the time, although we were gratified by the eye contact, it did not surprise us. On reflection, however, the rationale underlying these sessions did not consider the role of eye contact and it seemed difficult to incorporate it into our

therapy. It seemed that eye contact had an innate, preprogrammed quality about it but needed a relevant context in which it could become manifest.

b) Whilst until fairly recently psychologists assumed naively that babies learnt by imitating their mothers it seems from studies of infant/mother interaction (eg. Pawlby 1977) that the reverse is that case. Mothers imitate their infants, which is the activity that we had undertaken here.

Following the initial imitation sessions, the interactions with Judy began to deal with sequences and cause and effect relationships. The earliest form of sequence involved delayed as opposed to concurrent imitation. Judy would produce a complete behaviour then attend to the adult producing the same complete behaviour. Examples of cause and effect play are..

1) Judy taps my head.. I tap hers back with the same force.. she produces a stronger tap.. I reciprocate.. she produces a soft tap.. two rapid taps..etc.

2) Judy searches for a piece of paper to tear.. I move the paper out of reach. This becomes a repeated game where Judy's motivation is directed at playing this reciprocal game rather than in obtaining the piece of paper.

An interesting observation emerges from this last example. Though the explicit role of the adult in these sessions is to respond to the child, in practice the adult is active and can initiate activities. The question is, "When is it appropriate for

the adult to take the initiative?" Within the same day, the three therapists involved decided, spontaneously and independently within their session, to discourage paper tearing and to remove it from Judy's reach. The results in each case were the same reciprocal paper-snatching game. We can only surmise that the incident was in some way initiated by Judy.

Our basic therapeutic rationale allows us an explanation of this game. The initial structure we developed was that of identity between two systems. This identity, once established, allowed Judy to map co-occurrences and contingencies. Let's examine what is implied in the mapping of contingencies in the light of the paper snatching game.

Judy attempts to get a piece of paper from me. This situation involves two roles, those of holder and snatcher. Now, if Judy succeeds in obtaining the paper, and I attempt to regain possession, the roles are reversed. I become the snatcher, she the holder. As the game proceeds, it seems that Judy becomes aware of the game in its own right. More formally we might say that she becomes cognizant of the snatcher-holder relationship. The relationship is independent of the particular context. It does not matter who is the holder and who is the snatcher. This aside, in actual operation, Judy needs to know if she is snatcher or holder in order to act appropriately. Some information will be given by sequence..your turn, ..my turn. Alternatively, appropriate information is given by.. who is holding the paper. Thus Judy is enabled to attend to herself as an entity apart

from the actions that she produces. This hypothetical process may be the basis for the early development of body image and identity. Similar situations are involved in games such as 'peek-a-boo', 'pat-a-cake', etc.

Three months after the initiation of the therapy change was steady and progressive and an indication of the general nature of the change can be given by the following indices.

a) Vocalisation increased and occasionally she babbled systematically. eg. "Buh buh buh Puh puh puh ". Comprehension seemed to be increasing.

b) She became interested in activities not directed at herself and began to observe her teacher working with another child.

c) She began to initiate events in the classroom. e.g.

(1) On one occasion she went to the toilet of her own volition.

(2) Following a swimming session, her teacher had dressed Judy but had omitted to put on her shoes. Later Judy approached the teacher and thrust her shoes on her lap.

d) She was able to play social games at a distance. e.g. chase

e) She began to approach strangers from outside the classroom, other school staff noticed how much more outgoing she had become.

Two years later Judy is a very outgoing person and her outgoingness occasionally produces management problems. Her comprehension vocabulary is in the region of 40 words. Her babbling is continuous and she can now produce most sounds. As

yet her productive use of language is restricted to saying "please" in sign language to indicate a desire, and saying "no" verbally to terminate something.

Origins of Interactive Games

Let's firstly look at how BABEL might simulate the process of being imitated. We'll represent Judy's memory as a series of chunks, some of which we might term "stereotypes"

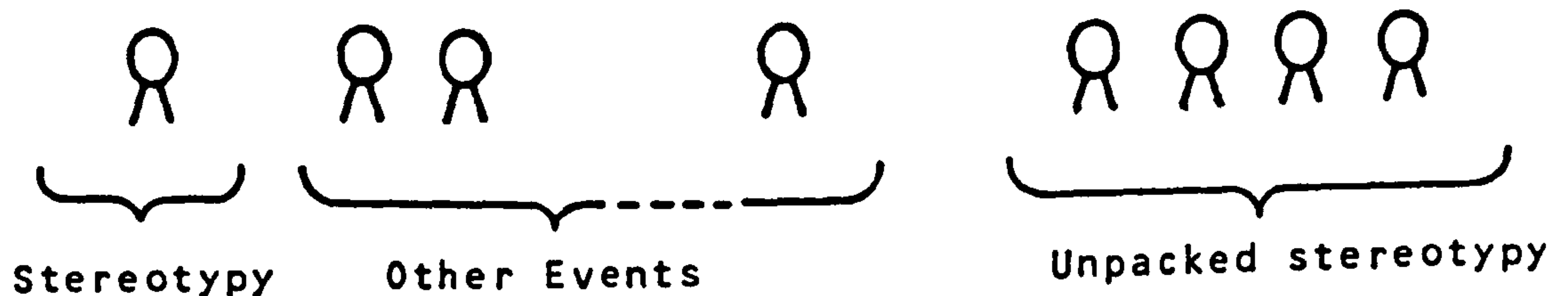

Fig 8.1 Schematisation of Judy's memory.

The "attended to" chunk operates a set of actions which effect a specific change in the world. So we can represent the stereotype as having three components

- a) Information that the action is appropriate.
- b) The action itself
- c) Feedback from the action

where the action and its results are synchronous. (Since when an action is operated the feedback, both visual and kinaesthetic, is experienced as the same continual process.)

When Judy is imitated, the effect is to produce a part of the environment which corresponds to the visual information

embedded in the hierarchy.

For this to be available the chunk must be in an unpacked state. So we have Judy using the visual part of her chunk to recognise the adult's actions. However it would seem that at this juncture she might not realise that the adult's actions are not her own. Differentiation between her own actions and those of the adult would presumably arise when Judy tries to attend to the kinaesthetic components of the adult's actions. These are of course part of the adult's private experience and not available to Judy.

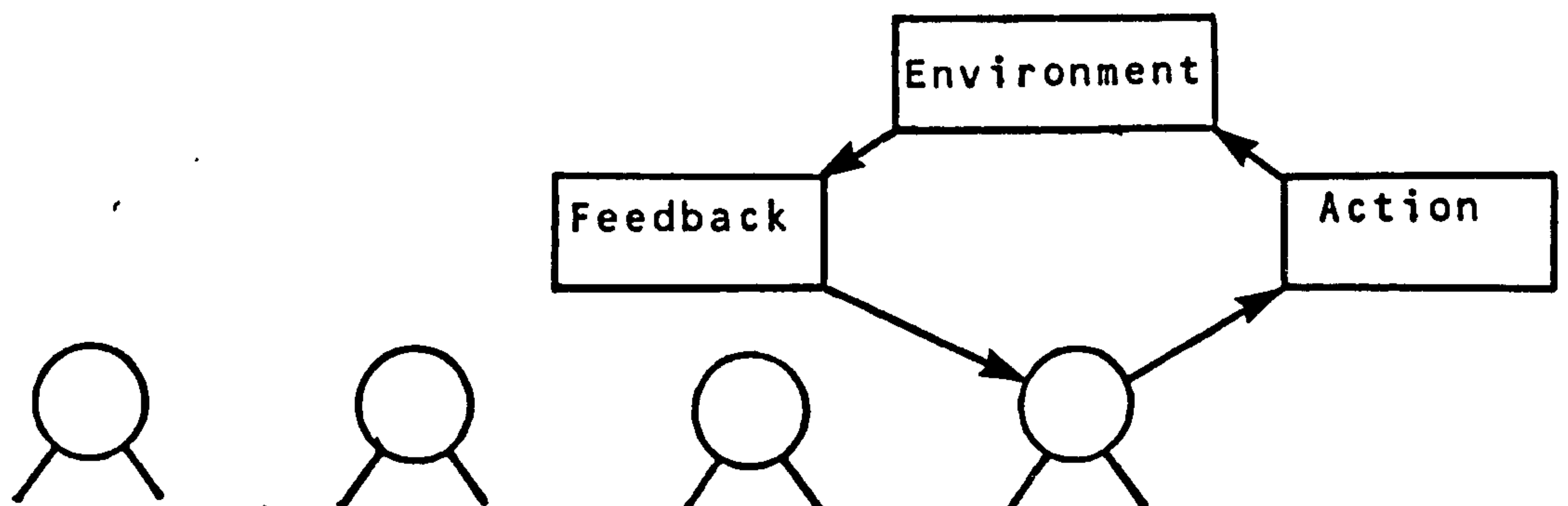

Fig 8.2 Relationship between chunk and environment.

The practice of imitating withdrawn and profoundly handicapped children often produces a remarkable surprise reaction when it is first done, and it is tempting to interpret this response as.. "what happened? where's my kinaesthesia gone?"

Whether an infant codes an absence is a difficult question. He may code not the absence but his response to it. The problem

relates to the Lacanian concept of Lack. (J.Lacan, 1977) For our purposes though it may be as well to avoid this question and to focus on what is similar. The absence of kinaesthesia would result in the chunk remaining unpacked and leaving the visual components accessible. Since BABEL works by replicating chunks, the original synthesis of visual feedback and kinaesthesia would still be available.(see fig 8.3)

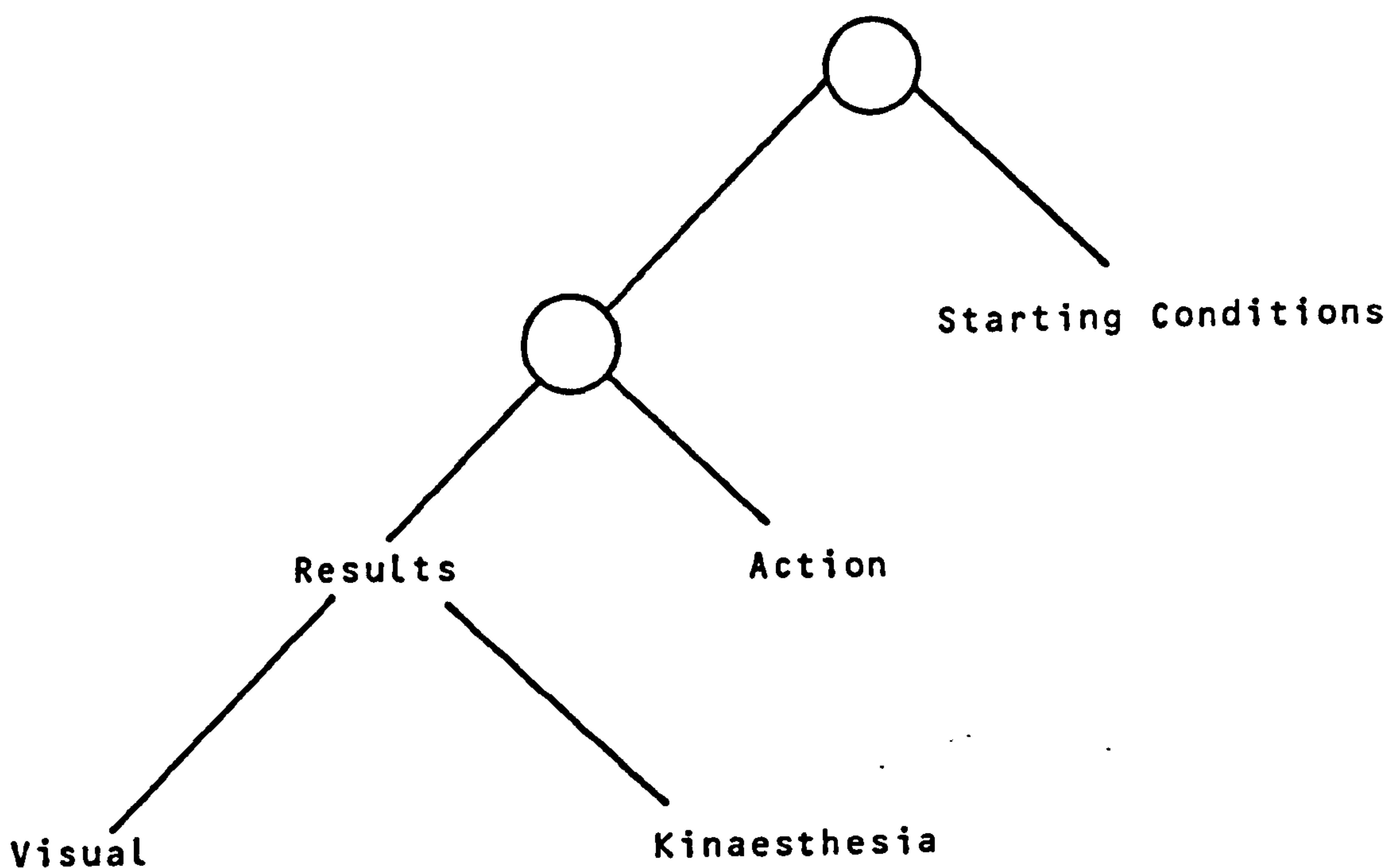

Fig 8.3 Availability of subcomponents in a chunk

This would provide an independent visual chunk which could be employed to build a partial representation of the adult.

It is difficult to produce a perfect imitation of another person so there are performance differences between Judy's behaviour and that of the adult. There are also contextual

differences. (E.g. differences in the clothes worn, etc.) Initially it seems that these differences are unattended but once a mapping of similarities is underway then it is possible to attend to the differences and to integrate them into the schema of similarities.

The use of delayed imitation would enable diachronic chunks to be built up whereby interactive sequences are coded..e.g. child's action..... others action.

Differentiation of such chunks would occur whenever someone behaved out of turn. Such differentiations would lead the child to attend to attributes which are specifically her own as opposed to the other's. The "other" will potentially be differentiated into the individual people that may engage in interactive activities.

It is possible that delayed imitation may contribute to the child's ability to suppress his own actions. Let's assume that the child is in the process of being imitated but he does not know whether the action is his own or the adult's. Let's further assume that he is attending to a chunk which refers to himself rather than to the other. In attempting to decide who is acting, were he to attempt to operate behaviours coded in his chunk then he would fail. If, on the basis of his uncertainty he chose not to act, then he would give himself the space within which to decide who the actor is.

In the sessions described here contact was made with Judy by using her stereotypies. Usually work is done with autistic

children based on the idea of suppressing the stereotypy. (E.g.,
Bucher & Lovaas, 1968)

A stereotypy has a compulsive quality inasmuch as once a particular stereotypy is "called up", the child seems captured by it. This seems especially apparent in distressing behaviours such as head banging. The behaviour may initially be a response to some upset, but eventually it seems in many children to acquire an autonomous quality. One successful way of dealing with, say, face slapping is to put constraints on the child and to engage him in other activities. The naive explanation given for this method's success being that the child forgets the behaviour, or loses the habit. There may be some substance to this.

BABEL might explain the technique as removing the conditions which allow access of the behaviour and then building a repertoire of behaviours such that a long memory search is required before the stereotypy is recalled. During the search, as long as the intervening repertoire is appropriate and accessible, other relevant behaviour will be selected and operated before the stereotypic behaviour is brought back into the action..

CHAPTER 9

The type of explanation offered in the previous chapter, though giving some insights into the nature of imitation as therapy, gives only a meagre explanation of the ongoing success of the sessions.

To attempt a fuller explanation we need to modify BABEL to include some new aspects. These will be employed to examine the question of optimism and pessimism and to elaborate a model of play as process. Firstly we'll recap how the search rules operate in BABEL.

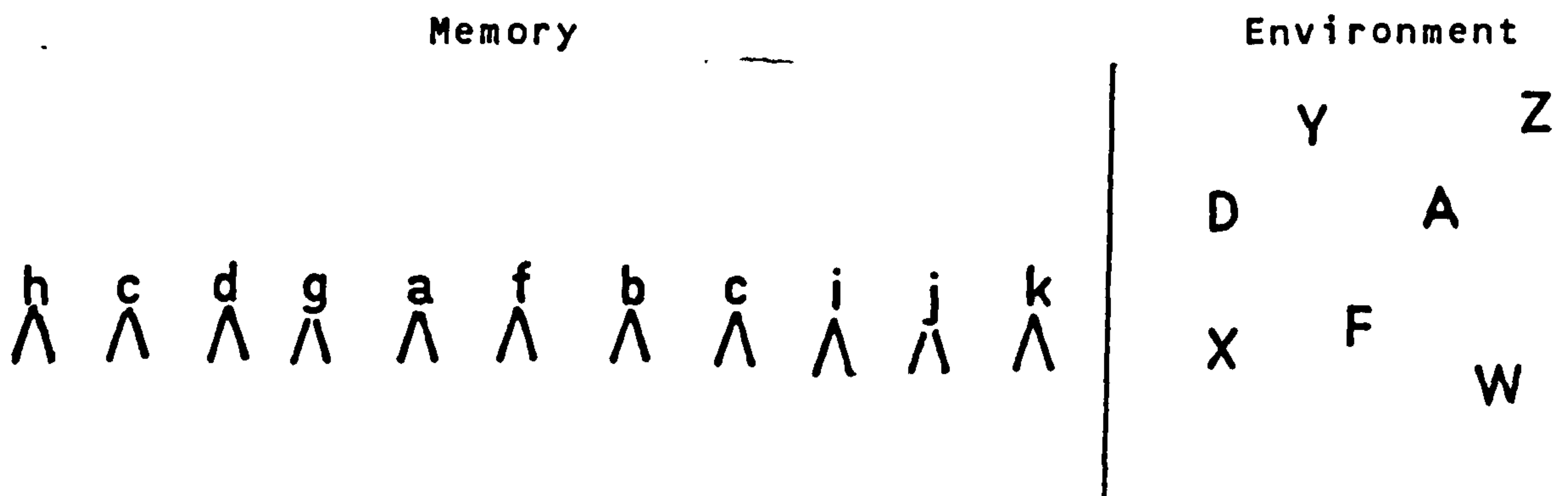

Fig 9.1 BABEL's basic memory structure

Let's consider the situation in fig 9.1 where chunk (d) is searched for and found. The search direction is now altered and moves forward: (g) is considered but not found. Under the present search rules BABEL would change search directions and scan backwards. However, as was suggested in chapter 4, if we allowed BABEL to tolerate this one instance of failure, it would then

move forward to consider chunk (a), which it would accept. Given this tolerance of failure BABEL would operate a stimulus sampling procedure, sifting out those chunks which were invariant in the sequence. But when the failure rate became excessive on the basis of some criterion then it would be appropriate for BABEL to respond by changing into the optimistic mode.

Let's then propose that BABEL responds, not directly to success and failure, but to the rate of success/failure, within the boundaries set by some constraints. What then might be the nature of these constraints? Some interesting insights are given by Schultz' (1969) model of sensoristasis. In this model (fig 9.2) Information load and arousal are linearly related and the organism has a preferred level of arousal, which is maintained by a homeostatic process.

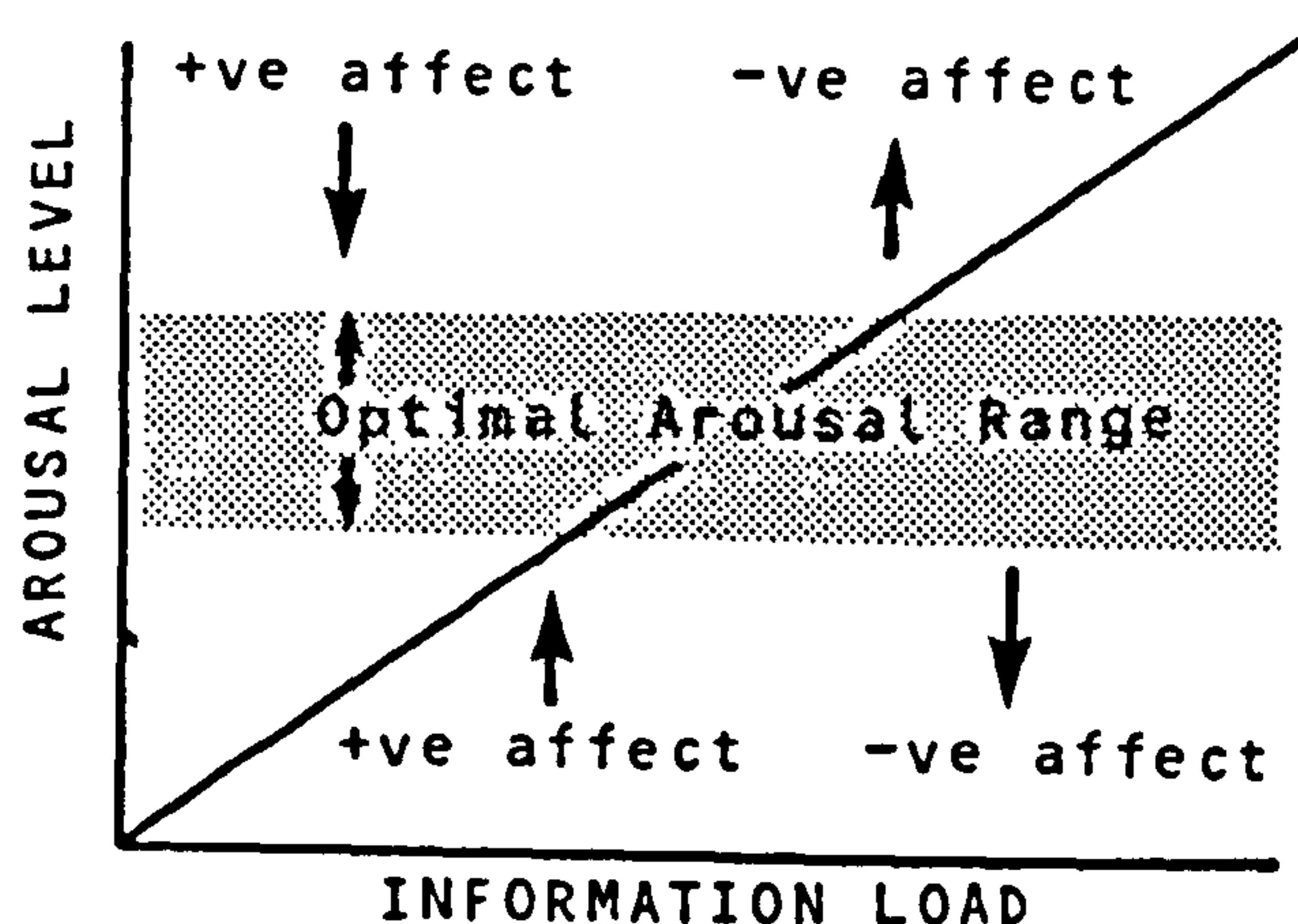

Fig 9.2 Schultz' model of Sensoristasis (After Ellis,1973)

Events which take the system out of its preferred range of arousal are experienced as having negative affect, and events which serve to bring it back into its optimal arousal range are

experienced as having positive affect. We can tentatively go further and label each affect as anxiety, boredom, effectance, and excitement.

As ELLIS(1973) points out, such a model has the ability to provide us with an explanation for intrinsic motivation. When a child is confronted with a problem, information load increases, and so accordingly does arousal. The child experiences anxiety and works on solving the problem. As the problem is being solved the information load decreases and he experiences effectance. When the problem is thoroughly mastered then information load decreases to the extent that the child experiences boredom. Accordingly he will begin to look for variations to the problem or even take on a new problem in order to increase information load.

We might borrow the notion of optimal arousal from Schultz and build it into BABEL. There are some other possibilities to choose from. Pribram (1971) has suggested that the concept of arousal is misconceived and that it merely represents the brain at work. So we might choose to talk about optimal information load. This might introduce the notion of limited capacity. Alternatively, we might interpret optimal information load as a function of process speed. Even within the framework of a concept of optimal arousal there are some considerable complications. At an intuitive experiential level, the concept of a fixed arousal level does not feel plausible. The actual range would vary with mood, tiredness etc. Furthermore the degree to which an event is

arousing is a function of how interesting or important that event is. If we are to build something along these lines into BABEL we have a wide and complex choice of alternatives.

Consider the following situation. BABEL is working away on a repeated sequence of events, building more and more economical codings of the episode and becoming increasingly optimistic. Unknown to BABEL it has been working on a subsystem of the environment which has, for a variety of reasons, been replaced by another subsystem. A real example might be mother, having been playing with her infant, hands him over to father who has just come in and is not privy to the game that mother was playing.

BABEL would experience this change of sub-system as a sudden increase of failure within that episode. Accordingly, it would become pessimistic, move into a back search until it finds coded events corresponding to the new situation. These it takes up and develops in further episodic chunks, and so again begins to increase its success rate and thus increase its optimism. On a subsequent occasion the world reverts to the original episode that BABEL was mapping. If in the original episode BABEL was enjoying a high success rate then its degree of optimism would change accordingly. Such a readjustment takes time. It would be adaptive if BABEL were able to immediately summon the same degree of optimism which it had arrived at in its previous transactions within that particular system. This level of optimism would then be modifiable in the light of further transactions with that system.

This it could do by coding an episode, not only in terms of sensations and actions, but also by coding the success rate.(see fig 9.3)

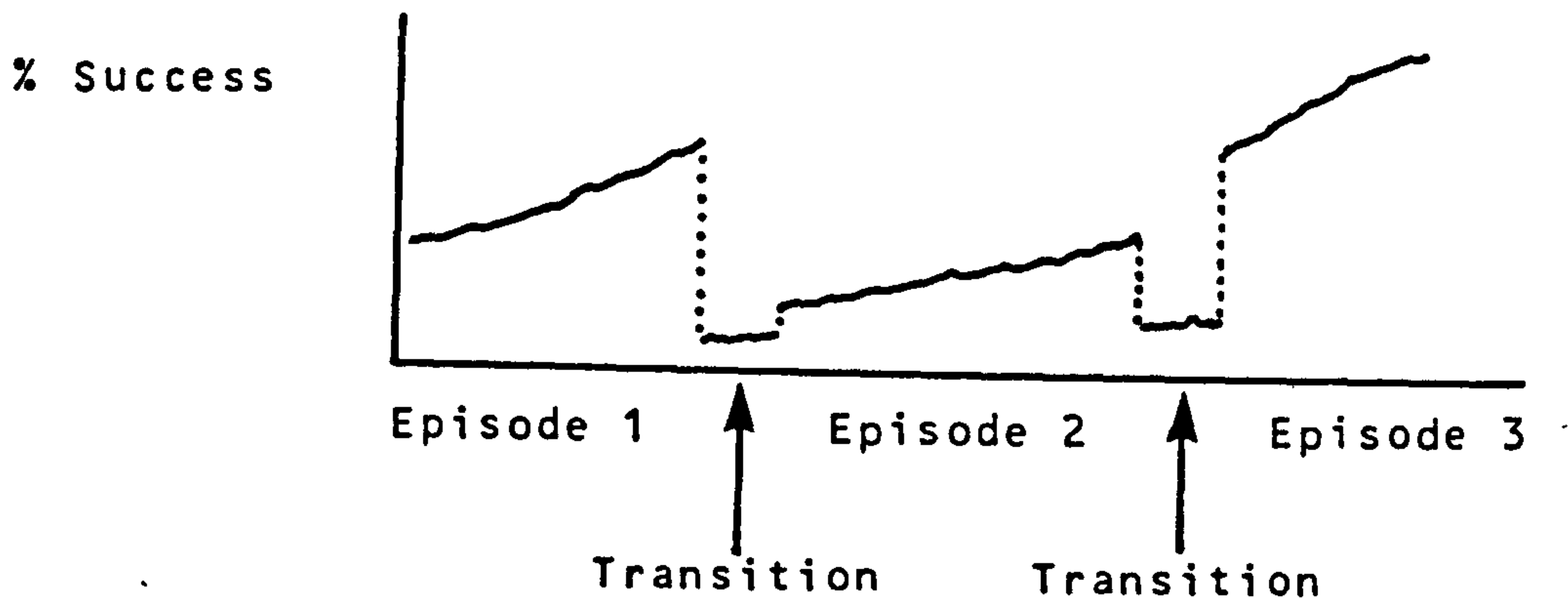

Fig 9.3 Sequential coding of success rates over episodes.

The question is now raised, "On what basis might success rate be computed?" This might be a ratio of the number of successes to some statistic. Possibilities for this statistic might be,

a)number of items in a considered chunk.

b)number of items considered in a given moment in time

The present framework does not provide a rationale for choosing between these alternatives. The choice of (a) is attractive because of its simplicity. However, choosing a different statistic would be interesting if that statistic were itself variable, inasmuch as a variable base might provide us with a medium for explaining different arousal levels. We shall leave this question unanswered and content ourselves with the proposition that each chunk is coded to include success rate, and this we can easily represent by search time. Long searches then

are indicative of difficult items, short searches of easy items. Within this we can build in constraints on what is to be considered in memory search.(see fig 9.4)

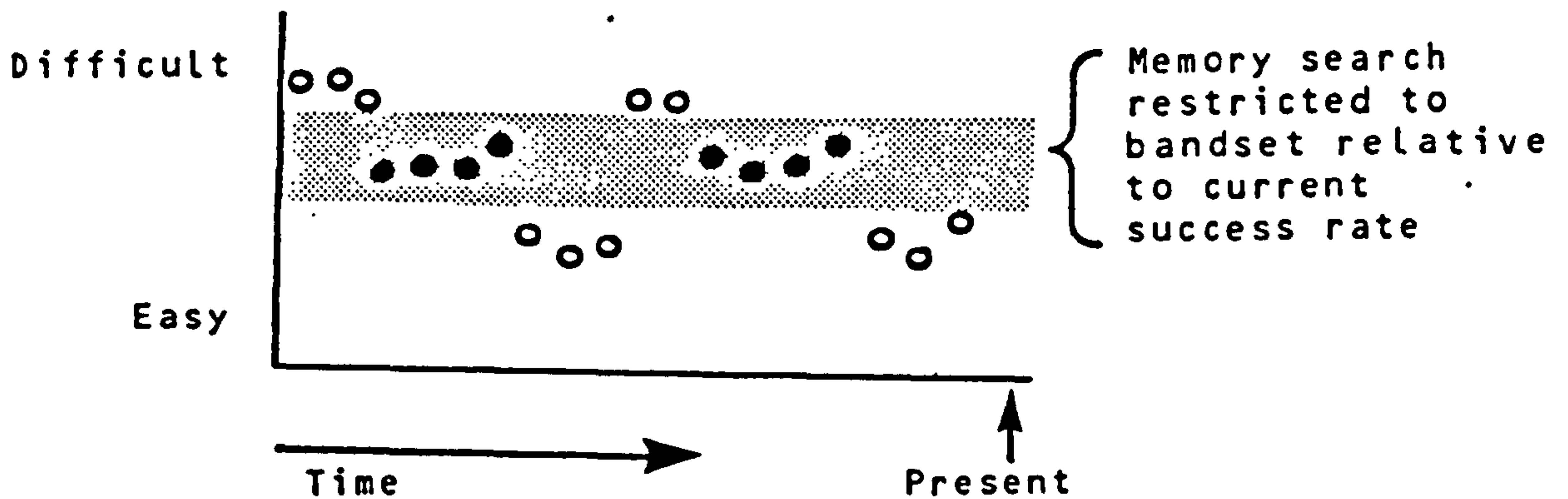

Fig 9.4 Restriction of BABEL's memory rearch

Searching takes time and if the search time is too long then BABEL will fail to keep up with the world. In other words the world will be changing at a rate faster than BABEL can build representations of invariances in the sequences. Conversely, if BABEL is too efficient, search time will be so brief that BABEL would be in danger of coping with the world at a rate faster than change occurs in the world. Consequently it would spend time waiting for change to occur, and in effect get bored. To work efficiently, it seems that BABEL would need to pace iteself to proceed at the same rate as change occurs in the world.

By restricting BABEL'S memory searches to a band determined by its current success rate we have a crude mechanism that will effect a pacing feedback. So if BABEL finds iteself dealing with a part of the world that presents difficulties it will restrict iteself to dealing with items that were previously easy. In so doing it will experience success and so will tend to look for

more difficult items. If it continues to succeed then it will countenance yet more difficult items. The converse will happen should it experience failure.

Bearing in mind that BABEL replicates chunks it has dealt with, then sets of chunks dealing with specific subsystems of the environment will be coded at various points and at various levels of difficulty. The sequence of these chunks will reflect BABEL's history of dealings with that particular subsystem.

Within the bounds of this pacing system, BABEL has other possibilities for pacing.

1) When an action is referred to in a chunk, BABEL may chose not to operate that action and thus free the environment from its interference, allowing the environment to "behave" independently of BABEL. New events will thus be permitted and BABEL will set about mapping these new events.

2) So far BABEL has operated the rules

1) <IF SUCCESSFULL, SEARCH FORWARDS>

2) <IF FAILING, SEARCH BACKWARDS>.

In line with a search band of appropriate difficulty we will now revise these rules.

a) <IF WITHIN SEARCH BAND, SEARCH FORWARDS>

b) <IF OUTSIDE SEARCH BAND, SEARCH BACKWARDS>

These revised rules will allow BABEL to play!

Let's assume that at different times BABEL has been coding a

particular subsystem of the environment with increasing success. In this coding it has selected a subset of the component elements of the subsystem and, by means of integration and differentiation, has been striving to form the most effective representation of the subset. Within this coding BABEL has been increasingly effective such that its search time, within this context, has decreased such that it is outside the search band. So even though BABEL is succeeding, rule (b) operates and it moves into a backsearch until it re-encounters elements which it entertained in its earlier encounters with the subsystem. (i.e. The variables that were originally discarded.) These are now available, either for integration and differentiation amongst themselves, and/or for integration into the main chunk.

So for example we have an original sequence which may be of two varieties..

A > M > B > G > C > D :: A > N > B > H > C > D

Selection of the invariant items in these two forms would lead to the sequence

A > B > C > D

following discrimination becoming possible.

[A], THEN IF [M], [B > G] ; ELSE IF [N], [B > H]
THEN [C > D]

The resulting effect would be to look at the conditions under which one of a set of variables will occur.

Thus BABEL plays and is allowed to decenter. In so doing it increases its search time, bringing it back to within its search band since rule (b) would again operate and backsearching would

take place leading to decentration. Our account of Candy in chapter 3 would be describable in these terms.

However, for decentration to work in this situation it is necessary that BABEL tends to remain in an optimistic mode in order that integration may happen. If BABEL back searches under conditions of difficulty and remains pessimistic then the possibility of integrating the newly attended to material, made available through backsearch, is precluded.

As was mentioned in chapter 3, the practice of attempting to force decentration by creating surprises only seems to work with some children. If it is attempted with children whose style of functioning is particularly obsessional it may result in outbursts of some intensity.

Intuitively, obsessionalism does have similar features to the unpacking that BABEL undertakes in its pessimistic mode. Highly obsessional adults of normal intelligence engage in a continual "checking out" of reality. They seem unable to take the risk of making assumptions and not checking that things are as they were a few minutes ago. They spend most of their effort in verification and this precludes the possibility of any further personal development which presumably involves decentration.

In Candy's case, it is highly relevant that the use of surprise as a technique was not administered clinically by a stranger, but in the context of a relationship with her teacher.

The term "relationship" has a wide range of uses and

applications. In this context, it is perhaps appropriate to emphasise the predictability of interactions within a relationship. Candy and her teacher knew and responded to the limited and regular demands made of each other.

Candy experienced her teacher as a context in which she was succeeding, and in BABEL's terms she would have operated in an optimistic mode which allowed her to decenter and integrate the information acquired when cups began to behave "differently".

The obsessively styled child, whilst not asocial to the extent of an autistic child, seems to seek success in the behaviour of objects and in routines rather than in social relationships. Furthermore, his prowess in seeking success is limited and his manner of operating has an anxious quality about it. This we might interpret as analagous to BABEL's pessimism.

Severely withdrawn children such as Judy seem to seek success in the much smaller systems afforded by stereotypies. Within such systems they acquire considerable competence which is difficult to emulate. Such children may bounce balls with considerable accuracy, spin pairs of cups in perfect synchrony, or engage in finger dances of great intricacy. This latter activity is analogous to the handwatching behaviour of the normal infant but the repertoire of handmovements has been developed to a considerable level of competence. This comment underlines the notion that many mentally handicapped children seem to maintain a particular developmental structure and elaborate its contents to a high degree, whereas the normal infant abandons that particular

structure in favour of new forms of increasing flexibility.

The child engaged in stereotypy has paradoxically attained a precocious state of equilibrium which Piaget suggested was, as an unattainable goal, that which motivated child development.

Attaining equilibrium entails building a model of the world such that the world becomes utterly predictable. The world is however such a complex system that it seems unknowable, but by means of processes such as Schultz' "sensoristasis" an open relationship is maintained with the world and a disequilibrium is maintained such that human models of their world are always striving to predict and control.

Children such as Judy attain equilibrium by choosing a subset of the world which is knowable and controllable, and which have a strong boundary around them. They relate to parts of the world as a closed system and preclude the possibility of attempting to build models of other subsystems of their world.

Further modeling of stereotypy

Within a system like handwatching BABEL would model the system as maintaining itself by continuously unpacking and exposing new elements within the limited elements of the eye-hand system and reintegrating and differentiating these elements to produce a variety of hand dances. Within such a system it may be possible to abstract the processes of playing, but it is within the confines of the closed system.

If, for a number of reasons, any attempt was made by BABEL to countenance material outside the closed system then it would soon experience failure. If the optimism/pessimism parameter was particularly sensitive to failure then BABEL would tend to unpack rather than integrate, and search time would not be decreased. The adoption of pessimism would be carried into the closed stereotypic system and would lead to unpacking within the system. This would create new work and operations within the closed system would return to a level dictated by the success rate band

Any excursions outside the closed system of a particular stereotypy would be constrained by the search band to consider only those other systems which lay within that band and which would have the same equilibrating properties as the original closed stereotypic system.

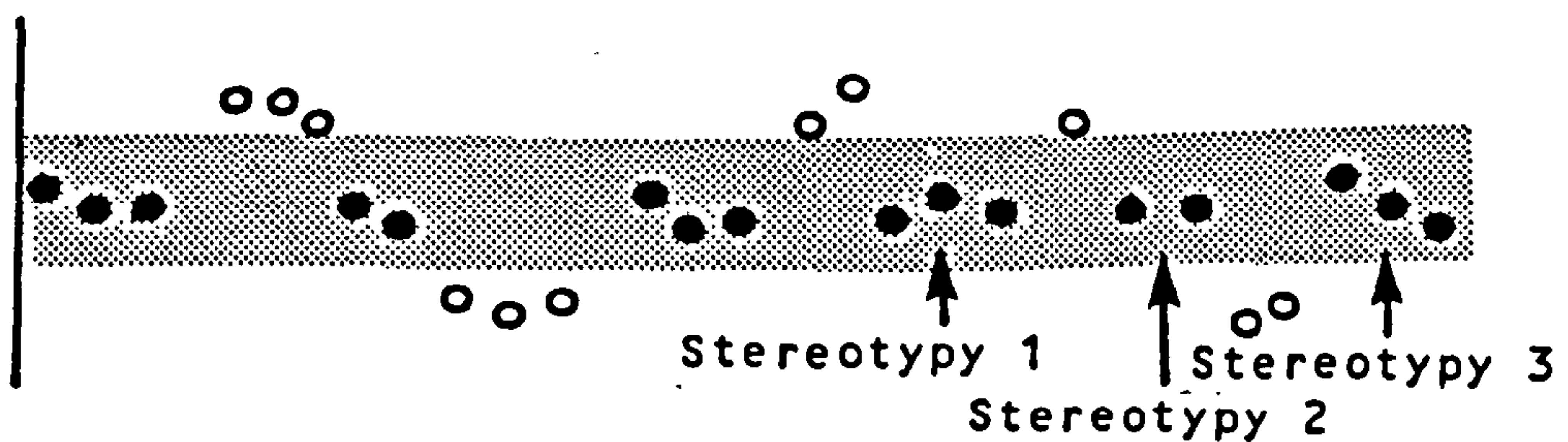

Fig 9.5 Maintenance of stereotypy within bandwidth.

Even where the child to have available behaviors not included in the tight constraints of a stereotypy, the effects of the various feedback systems would be, as it were, to dampen the available options. (See Fig 9.5)

At the risk of being pedantic let's describe this process explicitly through a series of diagrams.

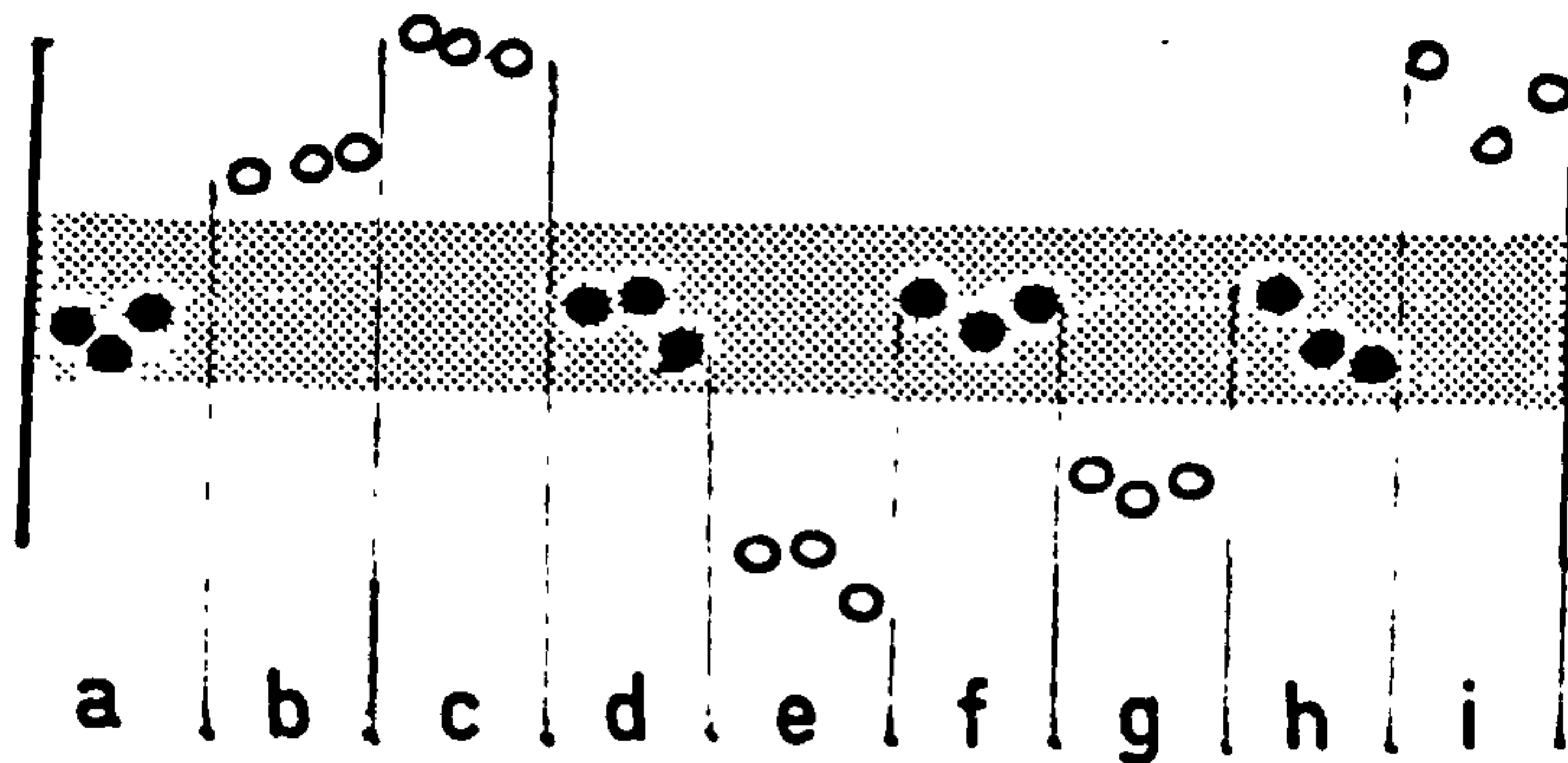

Fig 9.6

In fig 9.6 we have a range of chunks coded at differing levels of difficulty (a function of search time). An event occurs in the environment and a backsearch commences for a coding of what matches that event. Items corresponding to sections { h, f, d, b } are considered in turn until the appropriate chunks, as found in section { a }, are called up. Work on the chunks found in this section, under the [forward] search rules results in them being recoded at a higher success rate. Let's now add to process the idea that tolerance of failure increases so that the search band now moves upward to allow consideration of items in section { b }. Were the section { b } items linked easily to section { a } then the resulting work done on these would result in a new coding at the increased success level. However this presupposes that items coded in sections { a & b } belong to the same interlinked system. If they are not then section { b } items

are likely to be coded at an increased level of difficulty and the "tolerance of failure" search band brought down. (see fig 9.7) The experience of failure in section { b } elements would arise if BABEL was, at an early stage of its history, dealing with section { b } and sequential and coincidental variance was high.

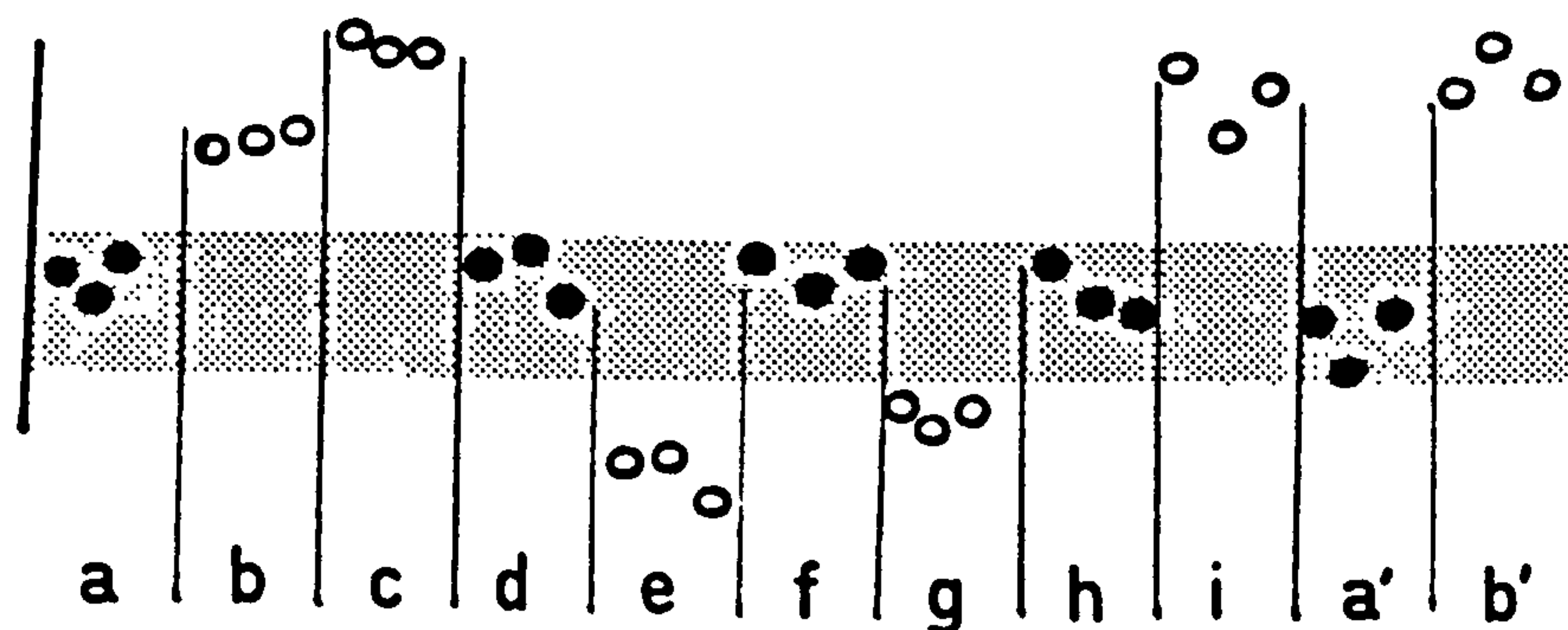

Fig 9.7

The result of this would be to separate material within BABEL's competence from material that was too difficult. Were the relationships between the success rate control parameters and environmental contingencies "healthy" then the effect on the search band would be to increase the percentage failure rate that would be tolerated, but in the situation described here the effect would be to make it static. However successive successful codings of section { a } items would result in their falling below the range of the tolerance of failure search band. If the search band starts at a very high level then there is a limit to its movement. (i.e. 100% cannot be bettered). If the search band is

originally more tolerant then, at the lower end of the band items will be subject to increasing pessimism and the process of unpacking, splitting, differentiation, will be increasingly applied leading to an increase in failure rate and a consequent recoding of the same items as being more difficult. The tolerance of failure search band would be lowered until the relationship between search band and closed system attained a dynamic equilibrium, and hitherto difficult material would no longer be attended to.

This aspect of non attention apparantly occurs in phenomena found amongst the mentally handicapped which could be diagnosed as functional hearing losses. This is demonstrated in the following case.

Charles

Charles is a 21 year old resident of a ward for autistic young men. He appears to be deaf. He does not repond to speech. Even an attempt made to suprise him with a loud bang from behind produces no response, not even an eye blink.

It was reported that Charles enjoyed playing with marbles. I sat opposite him and engaged him in some marble play. A game developed which entailed us rolling the marble to each other across the table top. This reciprocal rolling was performed for a few minutes. I then took the marble and, looking directly at Charles over the table, rolled the marble along the floor to him. Sometimes I rolled it to the left of him and sometimes to the right. On each occasion Charles correctly anticipated the side on

which the marble would appear. I was careful to use only a wrist motion to direct the marble and so avoid giving any cues.

Whilst it is possible that I was giving him some subtle cues it seems more likely that the only cue available to allow him to anticipate the path of the marble was the marble's rolling sound.

Often children with very limited vocal competence and suffering from apparent deafness can be enabled to give attention and effort to sound by the simple activity of being imitated, even when the sounds are restricted to heavy breathing, teeth grinding etc.

Let's take another look at why the practice of imitation works in such closed system children. Firstly, let's consider our model operating in an environment that is closely linked by imitating the stereotypy.

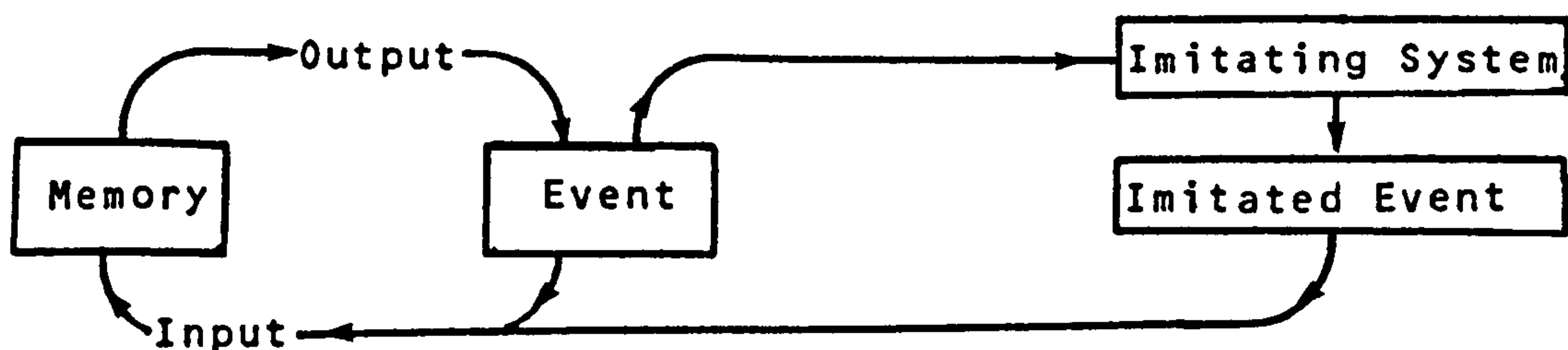

Fig 9.8 Initial status of imitation episode

Initially our model would not perceive a difference between its own activities and those produced by the imitator. In the case of BABEL, where input and output are via a teleprinter, this

would make no difference. However, were we to give a directional nature to the input/output device (e.g. a pair of eyes) then the imitator could intervene and substitute imitated events for the real thing. The bogus system is now attended to. This having been attained, highly contingent events can be incorporated. (Fig 9.9) This entails that the imitating system extends its repertoire of behaviours to generate contingent events.

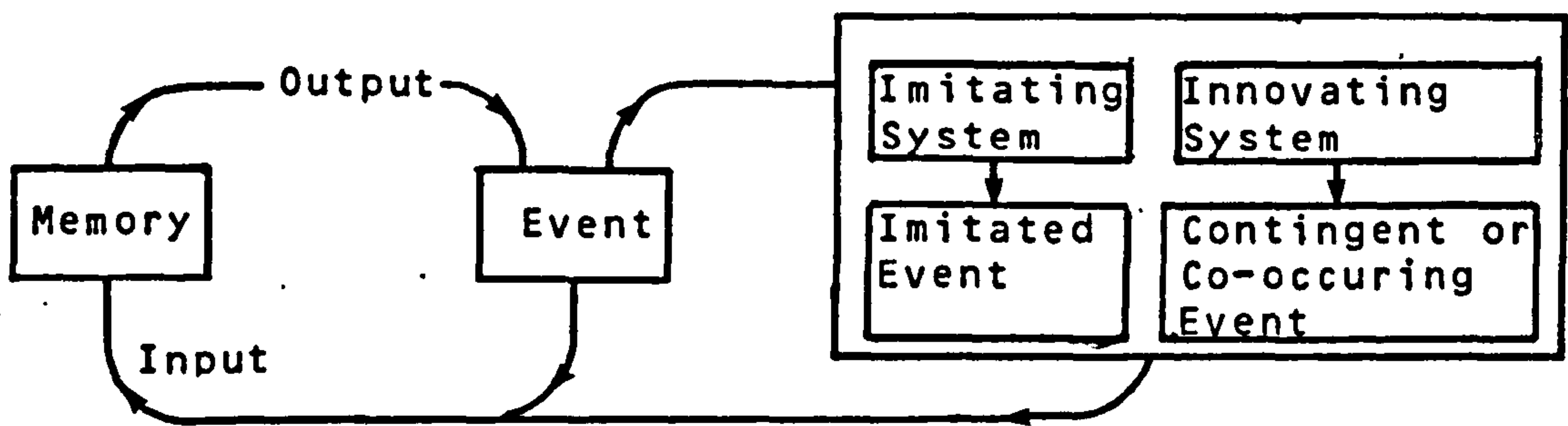

Fig 9.9 Extention of the imitating system to generate novelty.

Returning to the account that culminated in fig 9.7 we would now view section { a₁ } as being integrated with elements of the contingent system which are obtained from the model's past memory. These would need to be related to past experiences, coded at an appropriate and accessible level of success. In integrating these with the imitated elements our model would recode them at an increased level of success. Moreover, the tolerance of failure band would move to include more difficult elements in the range of material contemplated. As long as the novelty generating system provides new elements that are integrable with our model's

elements, and these remain within its range of tolerance of failure then the memory system will countenance the coding of increasingly difficult material.

Churchill (1971), in a study of autistic children engaged in a range of tasks of varying degrees of difficulty, experimentally manipulated his subject's success/failure ratio. He was thus able to experimentally manipulate the degree to which his subjects produced manneristic behaviour. Churchill further argues that if normal children were placed in a situation of unremitting failure they would produce very similar symptoms.

Kaufmann (1976), a father of an autistic child, convincingly claims to have cured his son by the practice of imitating his stereotypies. He set up a regime where he, his wife, and two enlisted therapists were engaged in imitating activities with his son for several hours each day. This resulted in a gradual decrease in the son's withdrawal. On occasions when the parents went away the boy, under the care of the two therapists and a friend, would typically regress. Kaufmann's claim of a cure is instanced by the occasion when his son responded to their absence not by withdrawal but by becoming very aggressive towards the therapists. Subsequently, his progress seemed much more substantial and robust.

In exploring and discussing what may be involved in pacing a developing system in its attempts to map a changing environment, we have introduced the possibility of a number of processes. One outcome of the exploration is the suggestion that it is the

playlessness of the mentally handicapped child that makes him mentally handicapped, and that his failure to pace himself with the world contributes to this state. Later, in chapter 11, we will look briefly at some ways in which this failure may arise.

In attempting to model these pacing processes we have ended up with a hypothesis that entails several feedback systems and to operate models of such systems it has been necessary to suggest parameters of responsivity.

When a model builder introduces parameters into his model, he is in effect admitting that he feels that he is at the boundaries of his model and lacks either the time, the motivation, or the inspiration, to attend to the implied problem. He can save face though by the promise of further work on the area.

George Kelly (1955) required that a psychological theory should be reflexive and should provide an explanation for its own emergence. The lack of time, motivation, and inspiration, that at this moment constrain this theorist, corresponds to BABEL attempting material that is outside its comfortable limits. Furthermore, this particular BABEL seems to be highly optimistic and has opted for more integrating than unpacking.

The discussion beginning with Candy Looking into cups has led us into the complex area of feedback systems controlling cognitions. I have avoided a simple conception of arousal in order to explore alternative possibilities, and these possibilities were suggested by Shultz' (1969) model of

sensoristasis.

Let's return to Schultz' model and see what parameters operate here. Possible quantitative varieties of the model can be described by two parameters..

(a) Mean optimal arousal

(b) Range of optimal arousal band.

The model as it stands is static but dynamic variations can be contemplated. Bearing in mind the earlier comment that the optimal arousal level may vary with mood etc., we could have a statistic to describe this changeability. We could also introduce another parameter indicating the definition of the boundary of the optimal arousal range, varying from well defined to fuzzy.

Simply using (a) and (b) gives us some ideas about mental handicap. A hyperactive child would have a high "preferred" arousal level. This would have the effect of restricting his attention to material having high information load and this load may be beyond the assimilative capacities of his cognitive structures. Conversely, a child with low optimal arousal levels would be restricted to low information loads and this would be manifest as subnormality.

A child with a very narrow range of optimality would rarely be paced with his world and would be typically anxious, or, at an extreme, autistic. A narrow band child with low mean optimal arousal would be a low functioning autist. The same narrow band but with a high mean optimal level would correspond to an agitated and hyperactive autistic child.

Stretching the Analogy

It is also possible to relate parts of the model to models of adult psychopathology, as was earlier indicated tentatively in the case of obsessionality. To do this we'll change the manner of representing our model. In chapter 3 the relationship between the linear structure of BABEL's memory and a network model was outlined. Returning to a network representation we can include the idea of difficulty of material by imposing the network on a terrain of hills and valleys, where altitude represents difficulty. The idea of an optimal level of difficulty is represented by a contour band. The model functions by walking along different pathways in the network but attempts to choose paths that will correspond as closely as possible to a particular contour. It's choice of contour level will change as it traverses the terrain. So if the model feels "fit" it will choose a higher contour and move uphill.

If we loosely relate our notions of coded difficulty with affect then the higher altitudes will have negative affect, and will in effect be repressed. An interesting corollary to this is that material at lower altitudes will also be repressed, since they are too easy. These too will have negative affect. This type of repression will be equivalent to overlooking the obvious.

Arieti's (1974) notions of schizophrenia draw attention to the high incidence of extreme affect in the schizophrenic person's thought processes. This suggests that the schizophrenic is operating at high altitudes as it were, and taking on material of considerable difficulty which is beyond that person's reality

related integrative capacities.

Depression would be analagous to a person choosing a contour that lies well below the person's capabilities. The subjective confusions between mild depression and boredom gives some slight support to this notion.

On the basis of the assumption that psychopathology is interpretable as disorders of interpersonal relationships, one aspect of therapy would be to give the client a field of appropriately interactive opportunities. The experience of success would allow for the possibility of non pathological operation of the tolerance of failure band. Within this the nitty gritty of changing cognitive structures would depend on the particular orientation and style of the therapist. Sloan et.al. (1975) in their comparative study of behaviour therapy and psychotherapy conclude that the dichotomy of good therapist/ mediocre therapist cuts across the two styles of therapy and that good therapists share, not a particular viewpoint, but a patients' perception of them as caring and concerned.

The model also seems applicable to areas of learning disorders of children of otherwise normal intelligence. In the case of children suffering from a maths block the model would argue that past mathematical problems are coded at a difficult level and as a result of difficulties encountered, search is restricted to easy items. As time passes mathematical elements of memory become more and more innaccessible. The result of this is that even relatively easy problems entail longer search times and

the child's competence may regress. However, if the child's teacher is able to take on the pacing function in a sensitive manner, she will ensure increasing success, the child's search band will progressively move towards the difficult range and events previously coded as difficult will be organised into more complex units and recorded at an increasingly easy level. If this process carries on far enough the child will become bored, take over the pacing function himself, and in effect become "intrinsically motivated".

A similar explanation could be applied to children with varying degrees of reading difficulties.* The original experience of failure would arise when the child was learning his letters, or even learning to talk, especially if there are hearing problems. The model would not discriminate between the possibilities that the failure originally arose out of a specific perceptual or motor problem or from an affective environmental problems, but the application of a transactional model would highlight the likelihood that even were the aetiology physical, the experience of failure would lead to an affective component which would exacerbate the condition.

If this is the case, even assuming that the root problem is intractable, the intervention of a sensitive teacher to take on the pacing function would help to undo the knots of the problem

* The model in its account of the development of syntagmic forms would provide a candidate explanation for the specific sequential disorders, both visual and auditory, that often present as a feature of literary problems.

and contribute to recoding the elements of letters at a more accessible level.

These indications of how the analogy might be applied to other areas are a side issue here. The last comment, however, brings us back to our concern with the mentally handicapped.

Even though, as was pointed out in chapter 1, there is little understanding of the organic basis of mental handicap, the existence of demonstrable lesions in some patients, more subtle chemical processes in conditions such as phenoketylurea in some other patients, and the existence of genetic abnormalities in others, leads one to assume that organic dysfunction has almost always a part to play in the problems of the profoundly and severely mentally handicapped.

In contrast to this proposition the arguments developed through BABEL have emphasised an explanation of mental handicap as pathologies of developmental process arising from experienced failure and an implication that these failures arise from pathologies in feedback of an arousal-like nature. It is tempting then to locate the organic dysfunction in the organic arousal control device of the mid and hind brain. Certainly this may be so in some cases but it is worth bearing in mind, as does Karrer (1972), that demonstrations of malfunction in these areas does not in itself mean that these areas are damaged. The abnormality may be a function of deviant inputs from other parts of the brain. The source of these inputs may or may not themselves be damaged for they may reflect deviance in their own inputs. The

means of communication between the systems may be the source of pathology... and so on. (see Berg 1974). It would seem that before we can confidently identify the organic basis of various mental handicaps we need a well developed functional understanding of the brain.

However, as this work hopefully suggests, we can develop some therapeutic devices even though we are profoundly ignorant of the organic functions underlying the problems of the child we are trying to help. Moreover, in our explorations so far the therapeutic principles suggested have had some relationship to the activities of mothers and to these we now turn as it may be that we have much to learn from them.

→

PART 4

MOTHERING

The subjective nature of indeterminacy

In considering the infant's problems in understanding his world, it would seem that objects are far simpler to understand than people. The behaviour of objects can be described by fairly simple discrete rules. People, on the other hand, seem to be probabilistic in that there seems to be no possibility of absolute prediction of a person's behaviour. Language represents an intermediate level of complexity. Adults can recognise the grammaticality of an utterance without explicitly being able to express the rule that they are using. For instance, consider the following sentences...

- a) I wish to buy the Turkish large red carpet.
- b) I wish to buy the large red Turkish carpet
- c) I wish to buy the red Turkish large carpet

Subjects will select sentence (b) as being correct without realising that they are operating the rule

[ADJECTIVES ARE ORDERED ACCORDING TO
THE AMOUNT OF INFORMATION EACH CARRIES]

It seems plausible to suggest that we can view the domains of objects, language, and people, as rule systems of varying complexity and that our relationship to these systems may go through three stages.

- 1) Having a partial and passive understanding of the system
- 2) Having a more complete and active understanding of the system such that we can construct elements of that system.
- 3) Being able to apply a second system (such as a language) to the first to give an explicit explanation (metalanguage) of what is going on. This in effect allows one to stand outside the system.

If such is the case, then when we find ourselves in a system which appears probabilistic, the indeterminacy is not inherent in the system itself but in our relationship to it.

Autistic children seem to follow the object, language, people sequence inasmuch as a severely retarded, autistic child masters only aspects of objects competence, and the more able autistic child may also acquire fairly considerable linguistic competence. Both are socially incompetent.

Bettelheim's (1967) account of "Joey the mechanical boy", and Emmanuel and Weirs' (1976) account of their experience with an autistic boy's use of a computer operated "turtle", both suggest that one manifestation of autism is an intolerance of probabilistic situations and a searching for closed determinate systems.

This intolerance of uncertainty can be interpreted as an intolerance of failure. Churchill (1971) suggests that what is manifested as autism is in fact a symptom of a high failure rate. He gave a group of autistic children a range of problems to

solve, and observed that as each child progressively failed in a subset of problems his autistic symptoms, withdrawal, stereotypic actions etc. increased. Conversely, progressive success in a subset of problems was accompanied by a decrease of symptoms.

Normal infants, on the other hand, chose people as objects of their explorations and only later chose to explore objects. They appear to take on the most difficult task first.

A plausible explanation for this contrast is given by Watson's work (1976) on the infant's fascination by contingency. He studied a phenomena originally discovered by Hunt and Uzgiris (1964) that a mobile, which has been constructed so that its motion is contingent upon the infant's actions, will elicit from the child the self same cooing and gurgling that mothers normally elicit.

Whilst it may be obvious to me that if I strike a tower of toy bricks with sufficient force that it will always fall over, this fact is not always obvious to the infant. Out of all the range of activities available to him, only one specific action will topple the tower. He may shout, wave his arms, kick his feet etc., but to no avail. Even when mother demonstrates how to do it, he may not understand the demonstration. However, when mother is the object of his actions, the world is biased to respond to him and his chances of succeeding in any enterprise involving his own actions are high. So, by and large, by responding in simple and consistent ways to actions initiated by her infant (e.g. imitating her infant) mother ensures success regardless of the

form or content. This regime of success promotion results in a highly confident explorer of the world. (the psychoanalytic omnipotent infant.)

The effect of this omnipotence is that later, when the infant attempts to apply an action to an object and fails, he will persist in his attempts, "blaming" as it were, not himself but the world. Even now mother maintains her role as success promoter. For instance, she compensates for her infant's lack of coordination, providing assistance in holding objects. Bruner (1973) terms such activity "scaffolding". Possibly the function of scaffolding is to allow the infant to cope with the cognitive problems he has selected without interference from unsought frustrations.

This typification of the course of infancy emphasises the emerging independence of the infant and his gradual establishment as an agent in his own right.

The infant fascinated by the contingent nature of mothers' games seems to be in a qualitatively different relationship with her than he was when newly born. Before being able to develop an understanding of the rules of mother's games he must begin by recognizing, at a primitive level, that there is such a thing as contingency. Where does this recognition come from? It would seem, as we shall see shortly, that this emerges from the initial negotiations that take place between mother and infant about the quantitative aspects of their relationship, in the way that mother and infant together learn how to ensure that the

infant is given information at a rate that he can cope with.

Bowlby (1969) states:

"In an ordinary family in which mother is caring for her child, no harm comes to him when she gives him as much of her presence and attention as he seems to want. Thus, in regard to mothering ... as with food... a child seems made that, if from the first permitted to decide, he can satisfactorily regulate his own intake"

The arguments in the last chapter led to the proposal that the mentally handicapped child either cannot, or innappropriately regulates his own inputs and outputs. Implicit in this proposal is the idea that to some extent, therapeutic understanding of mental handicap entails enabling such children to manage such regulations and that in some way, arousal processes play a part in this.

Stern(1977), Brazelton et al.(1974), and Papousek & Papousek (1977) have worked on the area of mother's role in developing the neonates' arousal system.

The Papouseks state...

"Paying attention to the relations between the course of learning and the level of alertness, we found that they can effect each other in both directions, i.e. that the course of learning may also influence the behavioural states in a predictable way (Papousek 1969)

Further evidence led us to the following assumptions regarding the regulation of behaviour in infants (Papousek & Papousek 1975)

1) Differences in waking behavioural states actually reflect different degrees of activation of behavioural mechanisms and strategies controlling the input and processing of information on the one hand, and the organisation of adaptive responses on the other.

2) There is a fluent transition evident between

the activation of such behavioural mechanisms leading to increasing attention, orientation, approach, exploration, and experimentation in one direction, and the inhibition of these mechanisms leading to decreasing attention, to habituation, avoidance, and complete inner detachment in the other direction.

3) Parallel to the mechanisms named above, corresponding changes may be seen in the autonomic nervous system and in the behavioural responses interpretable as signals emitted for the social environment.

Autonomic activation or inactivation controls the readiness for gross physical activity, among other things. Vocal signals and facial expressions may be differentiated only in rough categories in the first months of life, e.g. as signs of beneficial experience or pleasure, or as signs of displeasure, rejection or distress. Nevertheless, in a predictable way, they are also related to the discovery of a novel stimulus, an unexpected outcome of the infants' behaviour, the inability to find the solution in a problem situation as well as the achievement of such a solution (i.e. to the phenomena marking the course of the mechanisms named above)."

This statement of the Papouseks is clearly relevant to the issue of input/output control. Their choice of words in describing the effects of inhibition of these processes, decreasing attention, ...habituation, ...avoidance, ...and complete inner detachment, ...is an apt description of a profoundly mentally handicapped and withdrawn child.

In chapter 9 (Fig 9.9) the developmental necessity for an environmental system, analagous to the mother was presented. This subsystem necessarily promoted the experience of success. It was also pointed out that that the activity of this subsystem needed to be compatible, both with the content of what BABEL was operating and also with the quantitative aspects of BABEL's experience of success.

This raises the question of how the mother ensures that her activities are appropriate. The simple answer to this is that babies are very good at informing their mothers. We shall shortly examine some aspects of this process but the Papouseks' third assumption introduces the notion of signaling behaviour and to include this we need to update fig 9.9. (The figure is reproduced here to aid reading.)

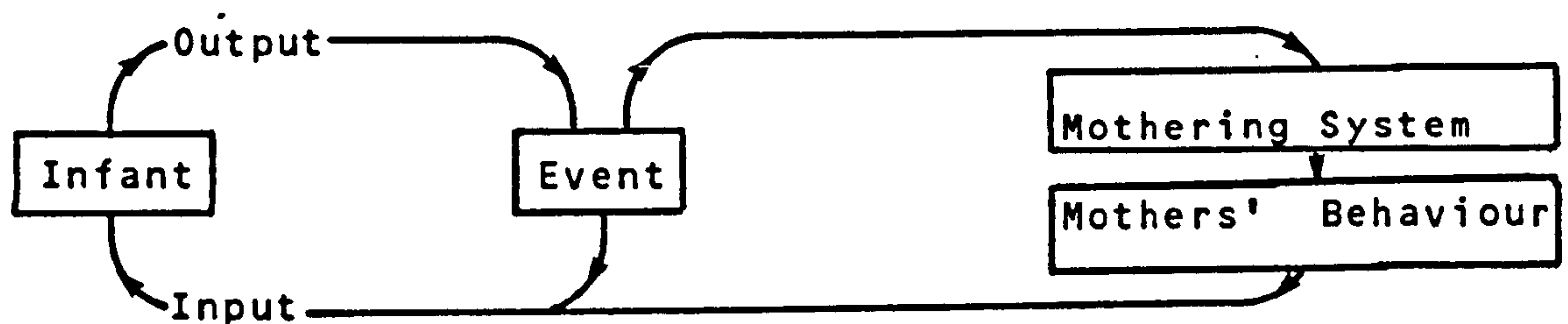

Fig 10.1 Schematisation of infant/mother system

If we examine this model and consider ways of updating it, one device would be the inclusion of a second output from the child directly to the signalling system. However, a superficial impression of a newborn baby would be that it doesn't behave...hence the traditional view of the baby as a blank tabula rasa passively waiting to be programmed.

The view emerging from studies of recent years presents the infant as a very different sort of beast. His behavioral states show an apparently innately regulated periodicity which seem to be synchronised with early events from earliest hours of life. Conden and Sander (1974) have shown from microanalysis of neonate/parent interactions that there is a synchronisation of

the infant's movements with simultaneous adult speech. Trevarthen (1974) has shown that two month old infants engage in speech-like patterns of movements involving lips, tongue, and hand waving in exchange with adults.

Many students have interpreted these findings as evidence of innate knowledge. Whilst there are many findings which give strong support to the idea of innate competences it does not necessarily follow that all infant behaviours have this status. For instance the synchrony of infant movement with adult speech can be explained in three alternative ways.

(1) The synchrony results from the child's perception of the rhythmical aspects of speech, and his subsequent integration of his own behaviour within the structure of the perceived rhythm.

(2) The rhythmical aspects of adult speech are functions of underlying "natural" physiological rhythms which are common to the species. So it is easier when talking to adopt a language whose rhythmical characteristics are compatible with one's own periodicity. In their evolution languages have developed on the basis of the species shared periodicity. This is a plausible explanation for the intercorrelation of infant/mother rhythm frequency but does not in itself give an account for the two being in phase.

(3) The shared periodicity results from the parents tendency to modify his/her behaviour to match the infant,

imitation being a very good example of this.

However these explanations are not necessarily exclusive. Explanations are possible which entail all these aspects. So it is possible that process 2 operates as a background condition within which process 3 operates making process 1 possible.

Whatever version we adapt, it is a fact that infants are active but the nature of neonate behavior is very primitive. At this point a schematization such as fig 10.2 seems appropriate. Here the child does not attend to his own behaviour but to the effects of his mother's behaviour. Mother, in a sense, attends not to her own behaviour but to the effects of her behaviour upon her infant. i.e. His behaviour is available as a signal which provides mother with a basis for evaluating her own behaviour.

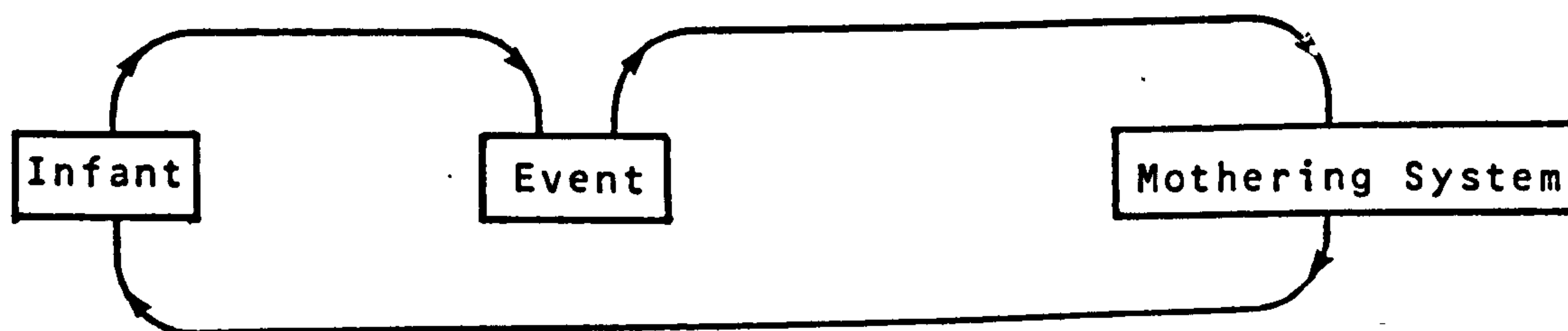

Fig 10.2 Early attentional system of the mother\infant

From this there emerges an increasing propensity on the part of the infant to attend to his own behaviour and to create specific behavioral events. Mother meanwhile monitors the infant's signalling behaviour and pitches her own appropriately paced contributions to his attentional arena. (see Fig 10.3)

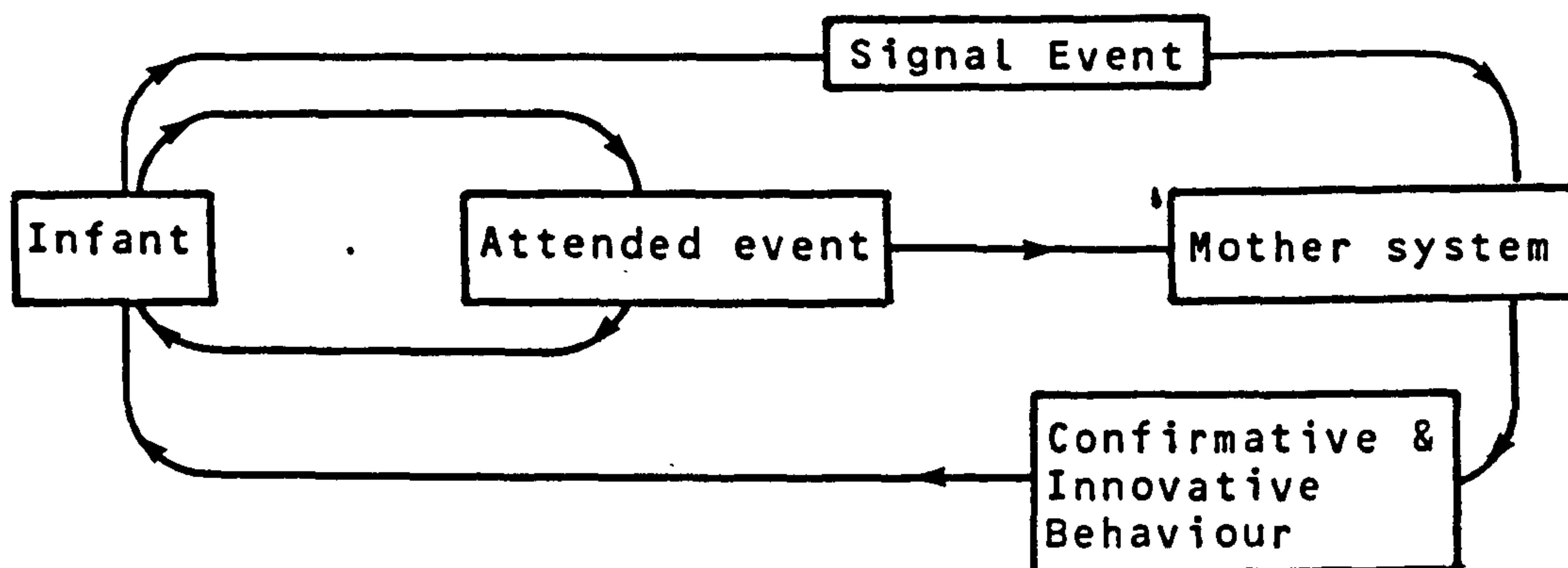

Fig 10.3 Two level feedback system of the infant/mother dyad.

An example of the emergence of such behaviour is given in the following therapeutic anecdote. This anecdote will also serve to introduce further material for discussion.

Robin

Robin is 13 years old and profoundly handicapped. Prior to mothering sessions with him he could not walk, even though there was no physical handicap. He was usually seen seated in a chair, head down, sucking his hand, salivating copiously, and whining or grizzling. There was no eye contact and the ability to control his gaze was very limited.

I undertook to engage in mothering games with him regularly for a period of time. Following an initial period of exploration a set of activities emerged which seemed appropriate on the basis of Robin's responses.

(1) Vigorously throwing and catching Robin elicited

anticipatory broad grins, increase in tonus, and widening of the eyes. In the pause after such a throwing episode, Robin would grin, slowly but emphatically shake his head from side to side and produce either a loud and repeated "Bah..Bah.." sound or blow a rhythmical raspberry.

(2) These sounds allowed me to imitate them, and over a period of three months their frequency increased considerably and there was a marked increase in his vocal repertoire.

On one early occasion Robin was obviously unhappy at the beginning of a session. His head was down and he was grizzling. I reproduced one of his 'happy' sounds whereupon, after a pause, he responded by raising his head and produced the same sound with a concomitant shift in mood. It would seem that the presentation of the "happy" sound resulted in a memory search until it was located and recognised (As would be demonstrated by the third item in the Uzgiris and Hunt scale of the development of vocal imitation.) In this calling up process the attached happy affect was also called up and this effected the change in mood.

(3) A later game which emerged involved laying Robin on his back on a large Sorbo (foam rubber) block. By kneeling at his feet and using my knees as a stop I was able to pull Robin to his feet. This was possible since he tended to hold his legs rather stiffly. This action was accompanied by my producing enthusiastic sounds such as " one.... two..... three.... P U L L !". The next item in the game consisted in my swaying Robin to and fro to the count of three and then dropping him onto his bottom

accompanied by sounds such as "GO", "BOOM", etc. This usually produced squeals of glee, and the usual vocalisations. On three separate occasions I reproduced the game in silence. Robin's responses on these occasions was completely neutral. This seems to imply that his coding of the game involved a synthesis of kinaesthesia and sound, and the experience of kinaesthesia in isolation was not readily available for recognition. (A similar phenomenon was mentioned in chapter 8 where the imitation of Judy was discussed.)

One such session was interrupted by a conversation between myself and Robin's teacher, at a moment when he was standing and waiting to be dropped. After waiting for several seconds, Robin bent his own knees, dropped to the mat and produced his usual response of delight.

Other than in babbling, as far as I know this was the first voluntary act that Robin had produced. I bent his knees, pulled him partially up and, by tapping his knee, prompted him to push. This he did. During that remainder of that session Robin would reliably assist in the pulling up and also anticipate and enact the drop.

This episode made it possible to begin working on developing his walking although some sessions were hampered by his propensity to gleefully drop on his bottom.

Other activities I engaged in entailed singing and rocking Robin, (to effect an integration between his kinaesthetic and his auditory systems), imitating his hand watching and

reproducing actions applied to himself. (Eg. If he tweaked his own lip, I would do the same to him. This is in effect imitation but the feedback is touch, rather than vision. The rationale for this activity is the same as that for engaging in imitation with Judy [page 136].)

In a rather gross manner these sessions with Robin seem to reflect some aspects of the normal infant/mother game. The activities involved the therapist in the role of confirmer, in the sense of imitating the child's activity or by repeating familiar events, and also in the role of innovator. The innovations introduced are judged to be appropriate if they produced a happy response.

Although at the time of these sessions I was aware of the notion of optimal arousal level, on no occasion did Robin approach a state which might be termed anxiety or distress despite some very vigorous attempts on my part to overstimulate. However it was possible to induce a state of helpless giggling, and this was interpreted as "too much".

Intuition

In the example of adult judgement about the relative appropriateness of the three sentences presented at the beginning of this chapter the subjects' relationship to the three sentences implied that they "knew how" without "knowing why". Likewise children abstract the functional rule structures of speech from adult utterances. These rules however remain embedded

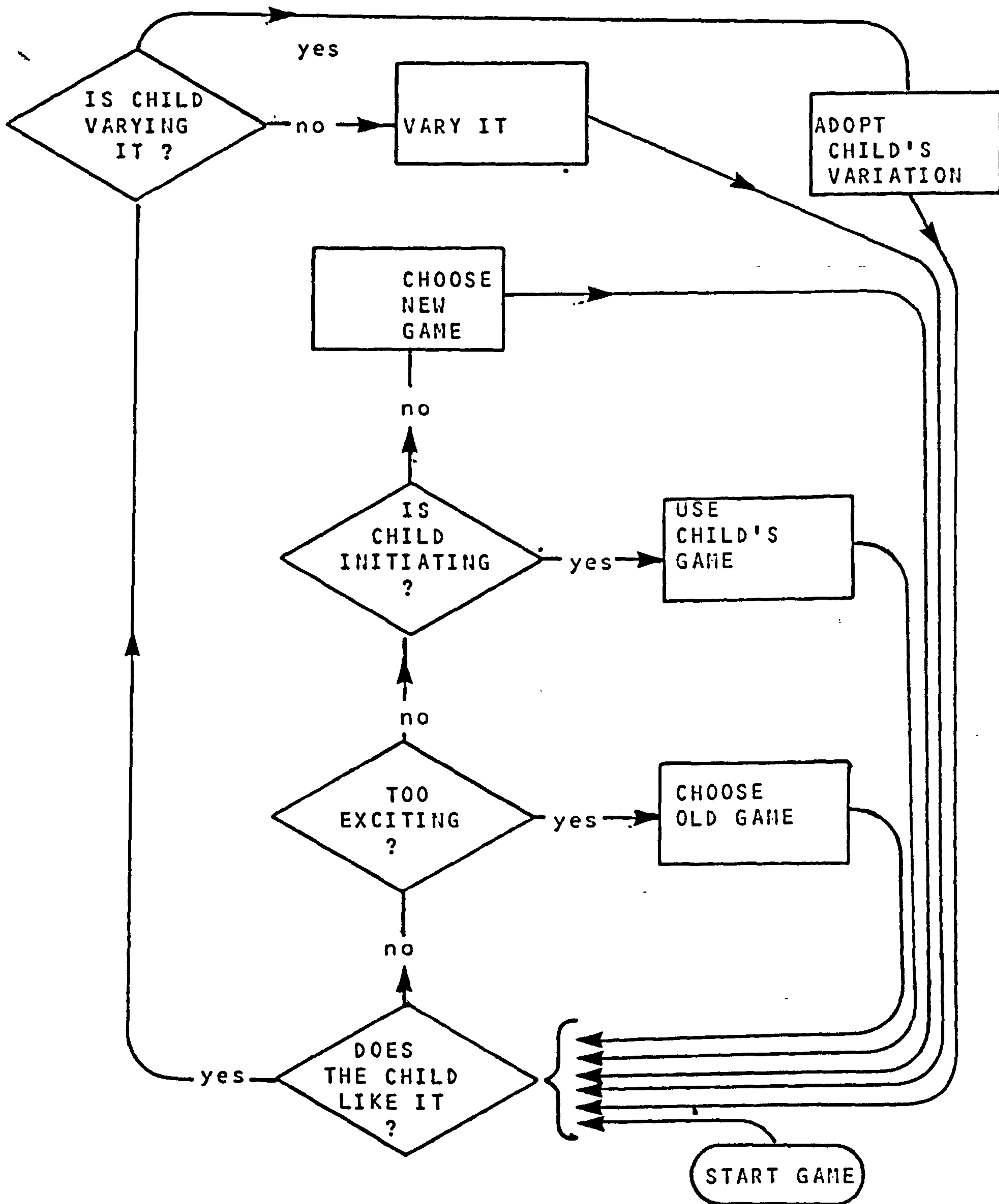

Fig 10.4 A flowchart of possible "Mother" rules.

in the matrix of their own utterances. To be able to talk and to represent abstractly these rule structures entails a rather contrived metalanguage. Likewise it is plausible to suggest that social interactions are rule governed but that even specialist students of social interplay have only a very limited metalanguage for abstracting these rules from the matrix of human social events.

Mothering is an intuitive activity, but this statement does not imply that it is innate or mystical. The flowchart in fig 10.4 represents a set of rules that claim to have some correspondence to the activities of mothers.

The diagram is intended to be didactic as well as explanatory and serves to draw the attention of those intending to engage in therapeutic activities with the profoundly handicapped to some of the characteristics of mothering.

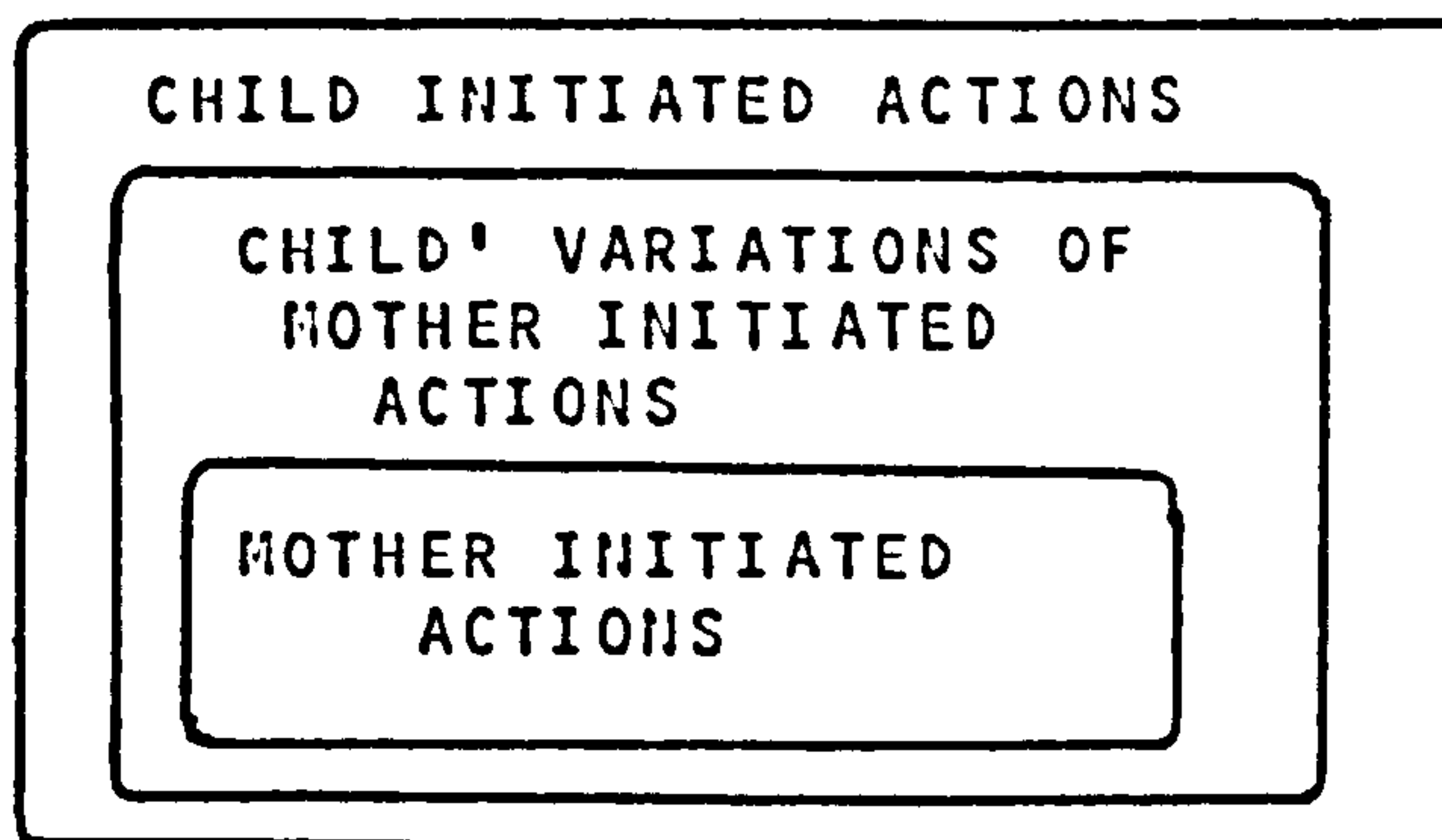

Fig 10.05

Essentially, the diagram represents three embedded levels of interaction (fig 10.05)

Changing from one level to the next is determined by the condition <DOES THE CHILD LIKE IT?>. At this level of interaction the responsibility to express the condition is with the child but reciprocally it is the mother's responsibility to respond to the child's communication.

Theoretically, the operation of these rules would result in a dynamic shifting to and fro between two levels but with a tendency for the focus of the shifting to move outwards as shown in fig.10.06.



Fig. 9.

Fig 10.06

The result of this process is the state where the child takes over responsibility for responding to the <LIKE IT?> condition, and this degree of control would be necessary before the child could begin to tackle understanding the less responsive inanimate parts of his environment.

Bruner(1973) characterises the child in play as being "buffered from the consequences of his action", and goes on to describe mothers' role as a scaffolder. This characterisation of

mother is commensurate with the formulation presented here but it also draws attention to mothers' role when the infant is engaged in object play. In social play, attention was initially on the mothers effects on the baby but later mother herself becomes the focus for baby's attention. In object play he no longer attends to mother, who becomes a background figure who is taken for granted. However, Bruner emphasises that mother still maintains an important function in the form of subtle interventions into her baby's object play. These interventions ensure the baby's success in attaining tasks he has set for himself.

An example of such an intervention would be the toddler doing a simple jig saw puzzle, and mother, recognising that her child knows where a particular piece goes but lacks the necessary coordination to implement his plan, intervenes by shifting the board to compensate for the child's lack of coordination skills.

As Nelsons' (1973) study (discussed in chapter 5) shows this process continues in early language acquisition where mother ensures her child's success in communication by referring to what she thinks her child is trying to say rather than to what he says.

Jean Berko Gleason (1973) demonstrates that this role is not restricted to the mother. Her observations of how the family talked to the toddler showed that, with the exception of the three year old, all the members of the family talked using a syntax which was slightly ahead of the toddlers' productive

competence, but that the messages they gave him were within his grasp. The 3 year old seemed to have enough to do in dealing with his own language acquisition let alone take on the problems of another.

The families' ability to generate a novel syntax seems amazing. One explanation might be that they sample their toddlers speech, then undertake a syntactic analysis, compute an index of complexity, increase this a few points, then synthesise a new syntax with the updated index of complexity using a set of universal rules. Such psycholinguistic virtuosity would make the Chomsky of the 1950's green with envy since it would entail that the family had a complete grammar readily available. Such an explanation does seem implausible if we restrict our view of a grammar to a set of syntactic rules since the family's processing of a number of grammars would entail a considerable memory load.

If our conception of a grammar is broader and includes semantic aspects (Filmore, 1968) then another explanation becomes possible. It seems more likely that the structure that the family employs in order to generate utterances addressed to the toddler is their understanding of the child's growing understanding of his world. By referring to this semantic structure and with their own social/ linguistic competence it would be possible for them to generate the appropriate utterances.

Some insight into this idea of knowing the child's semantic structure can be derived from my own experience as a father. Up until our son reached the age of three it was usually possible

for my wife and myself to be able to trace the origins of the questions he asked, and it seemed that we had a reasonable mapping of what he knew and experienced in his world. However, with the commencement of his attendance at playschool he became privy to sources of information that were not available to us. Consequently our knowledge of his semantic maps became patchy and we could no longer account for the source of every question.

Berko Gleason's study draws our attention to an aspect of the parenting role which deserves some emphasis. The process of mothering entails not only the promotion of success but also, paradoxically, the creation of problems. The sayings, "Nothing succeeds like success." and "You only learn from your mistakes". are both in complete contradiction to one another, but at the same time both are true. As was suggested in chapter 9, the experience of success leads the child to attend to new material and to integrate this material. The "healthy" experience of failure promotes differentiation and splitting.

It seems that some non institutionalised mentally handicapped children fail to learn to talk because their mothers are too good at understanding their intentions, and such children are never confronted with the weakness of their adopted system of communication. This too happens in institutions, especially with "endearing" children.

Bruner's (1973) notion of scaffolding reintroduces the notion of systemic asynchrony. The act of scaffolding seems implicitly to recognise the multilinear nature of development

since it recognises that the child, when dealing with tasks involving two systems, is developing his competence in one whilst mother attends to and supports the other. It also seems that in so doing, mother enables development of the other.

Furthermore, in the jigsaw example, the perceptual-cognitive aspects of the task will develop perceptual competences that may serve to inform the perceptual-motor system. This type of process is analogous to the use of "bootstrapping" to improve inference (i.e. "pulling oneself up by one's own bootlaces." see Goldberg, 1970 & Humphreys, 1981)

Another example of bootstrapping seems to happen in the development of phonology. When the infant learns to babble, he treats the content of babbling as an isolated system which has no reference to meaning. But babbling does not in itself produce the full repertoire of sounds or sound combinations required for his mother tongue. The same child, when later he has acquired some language, will employ semantic knowledge to help him discriminate between sounds. For instance a child unable to discriminate between "i" and "ee" will learn, on the basis of confusion or laughter by his parents when referring to daddy's "fit", to make the necessary discrimination.

The success of such feedback would suggest that the child has some primitive cognizance of his parents' communicative needs and such events would contribute to the development of his model of his parents.

The echolalic child masters such discriminations without reference to other systems such as semantic structure. This seems a more difficult path to take than that taken by the normal infant.

The course that this discourse has followed could be taken to imply that all the mentally handicapped child needs is to be mothered and all will be well. This is a function of the model of mothering proposed in fig. 10.4 not discriminating between normal processes and those of the mentally handicapped. In order to develop this discrimination, the mothering model needs some qualification. The model, as a description of mothering, makes the following two assumptions.

- (1) The child has responsibility for deciding the boundaries of mothers activities. e.g. Too boring, too exiting.
- (2) The child is able to communicate his enjoyment of her activities in an appropriate manner.

These assumptions do not discriminate between the processes of the normal infant and those of the mentally handicapped child. Furthermore the flowchart makes no reference to the content of the mothering game and it may be possible to have pathologies of content.

In chapter 9 the notion of an optimal level of arousal or difficulty was introduced and it was suggested that there were several possible explanations of how processes in this area might operate. Some of these ideas involved notions of slow processing, oversensitive modulation of the arousal band, mismatch between

arousal band and appropriate richness of information etc. These possible explanations involved some tenuous assumptions and speculations, which is fair practice, but the strongest general explanations that emerged were:

a) The possibility of pathology in the control processes themselves.

b) The possibility that abnormal behaviours in such processes may be functions of disorders in other areas, organic or environmental. The effect of these disorders would be to cause an unremitting experience of failure which would be manifest as a disorder in the control process

These two possibilities are not seen to be mutually exclusive and in each individual case either or both may apply. The question is raised, in the context of the present chapter,

"Assuming inappropriate arousal levels, are there environment entailing processes which would, in any way, modify the regulatory processes?"

In the account of success promotion with Judy, some claim is made that such modifications occurred, but there are other possibilities.

One possibility is already widely practiced, and that of course is chemotherapy. The problem with this practice is that without full reference to the nature of the child's processes it is rather a hit and miss affair. Certainly it may produce the desired effects but it is possible that a regime which entails

the monitoring and coordination of chemotherapy with mothering like practices would be dramatically effective, but alas our understanding of the general processes involved are minimal and for such a project to be possible we would need to understand the process idiosyncracies of each individual person.

Brazelton, Koslowski, and Main (1974) draw attention to a facet of mothering which suggests that some work is done by mothers in helping their infants to modulate arousal levels. Their work is based on microanalysis of interactions and attends to whether the baby is initiating mother directed behaviour or not (this discrimination was based on the child's looking intent), and on mother's response to baby's behaviour. The process is represented graphically in fig 10.06

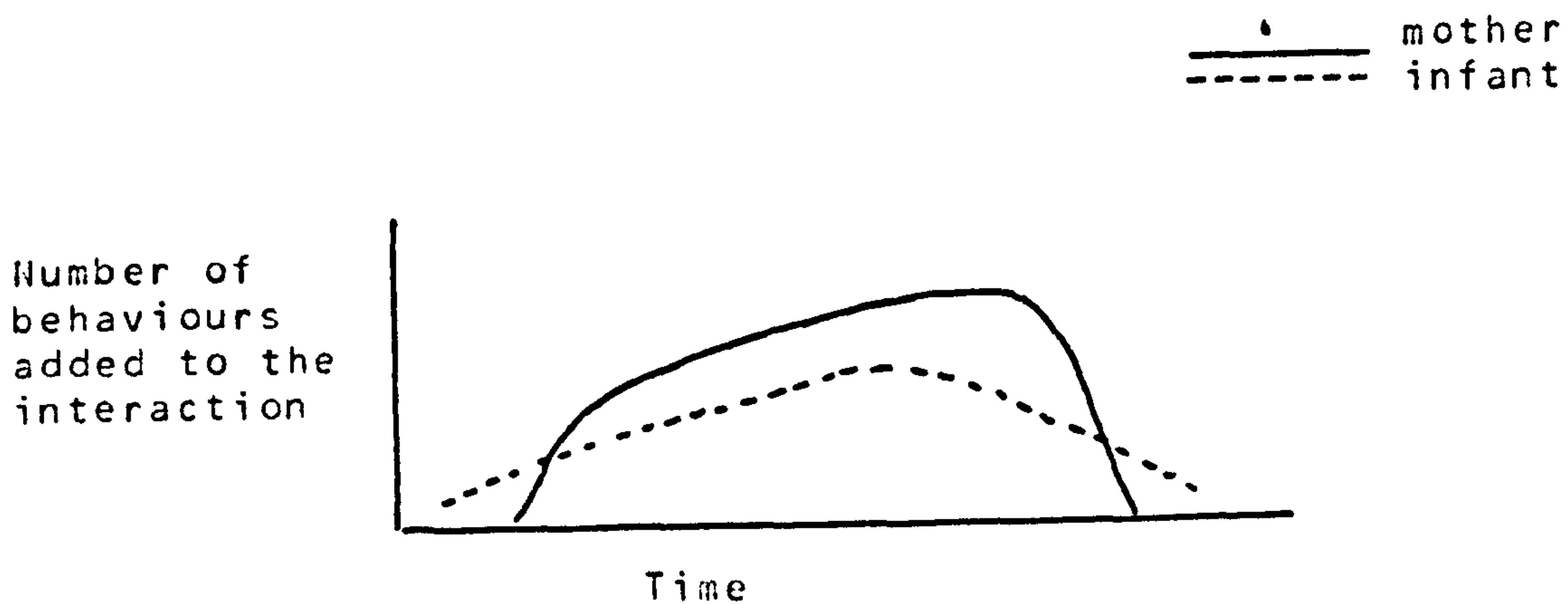

Fig 10.06 (After Brazelton et. al. 1974)

The suggestion then is that mothers respond, not directly to the intensity of their infant's behaviour, but to the direction in which the infant wishes to go. So if the infant is increasing the

intensity of his interaction with mother her response is to enable this. When the infant "judges" that the interaction is "too much" and pulls away, mothers' response enables the child to pull away.

Brazelton et. al. further demonstrated that where mother responds to the infants pulling away by persisting in attempting interaction then the period during which baby looks away is increased (fig 10.7)

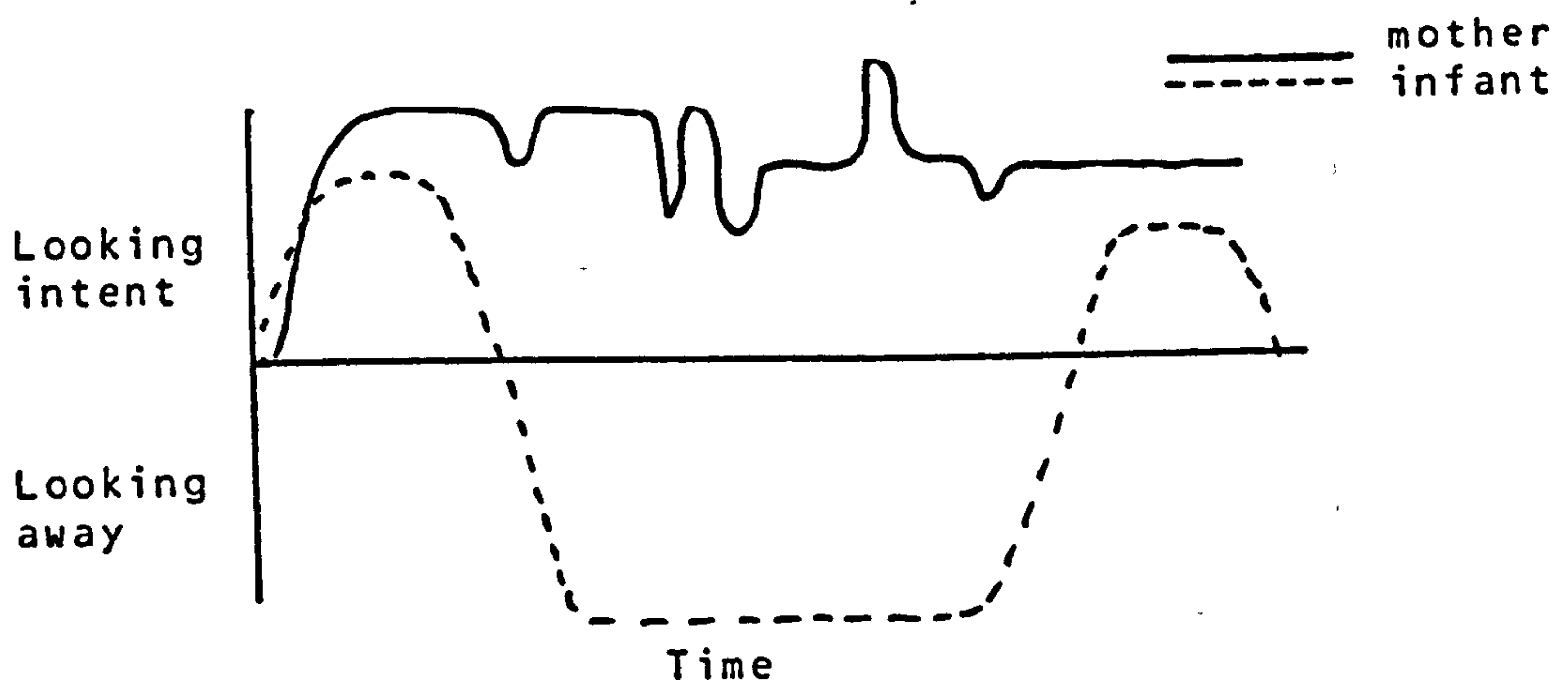

Fig 10.7 (after Brazelton et. al. 1974)

Another possibility that may occur in this process is that mother can decide if baby is getting "overexcited" and accordingly introduce calming behaviour. In our flowchart representation of mothering (fig 10.4) this would be equivalent to mother overriding baby's signals for more and returning to the quiet old games of rocking, cuddling, etc.

Some normal children respond to fatigue with an almost manic hyperactivity which elicits a containment from their parents. In the folklore of parenting we have the expression "laughter turning to tears", or the Welsh version "play turning bitter"

The signals which mother monitor during this period entail laughing, cooing, etc. but especially the direction of the infant's gaze.

- The processes suggested by Brazelton et al. can be directly employed with good therapeutic effect with the mentally handicapped withdrawn child. The activity can be described as using the child's eye gaze as "permission" to interact, and gaze aversion as "withdrawal of permission". The effect seems to be to give the child deliberate control over the adult, and the certainty that he can "switch" the adult "off" allows him to take interactive risks.

The therapist need not initially use eye contact since such children often seem to practice deliberate gaze aversion, and the criterion for permission is the child's looking, not at the adult's eyes, but at his activity. This has much in common with what Bruner (1975) termed "the negotiation of joint attention". The activity is likely to be initiated by the adult and may involve imitating the child's activity, tickling him (although this often seems to be too direct) playing alongside him with an interesting toy etc.

Howard

I employed a rather tenuous form of "joint attention" with one autistic adolescent boy. In the first session with Howard I initially gave him his head and walked alongside him wherever he went. After an initial period of apparent puzzlement, he seemed to be testing a hypothesis about what I wanted from him. He walked from the hospital school to the ward gate and then waited for me to open it for him. This I did not respond to. After a pause he walked away and walked a route around part of the hospital with myself walking alongside. As this was in progress I noticed the variety of sounds produced by his feet and produced slightly exaggerated imitations of these sounds. During the walk there seemed to be some further testing when Howard set to go outside the hospital gate, but when he saw that I was not going to follow him he turned back and continued his walk within the grounds. Throughout this period I gained a strong impression that he was attending to the sound of my feet. The walk culminated in us both walking in convoluted circles on the hospital lawns with Howard grinning broadly and glancing occasionally in my direction.

Further sessions in the classroom, using his gaze for interactional permission led to a noticeable increase in his awareness of his surroundings. Following these sessions he went on holiday with a group from his school. This, coupled with a decrease in his medication, produced a moderate but very noticeable increase in his outgoingness and level of activity.

I have also operated in a similar manner with an

institutionalised chronically schizophrenic lady and effected very noticeable changes in activity and sociability. An account of the case is presented in appendix 2.

It would seem that asocial, or autistic children actively withdraw the signals that are the currency of mothering games, but some blind children and some profoundly handicapped children do not have the obvious means available to signal to the mothering figure.

Low Arousal
(Asleep)



Moderate Arousal
(Alert)



High Arousal
(Distress)

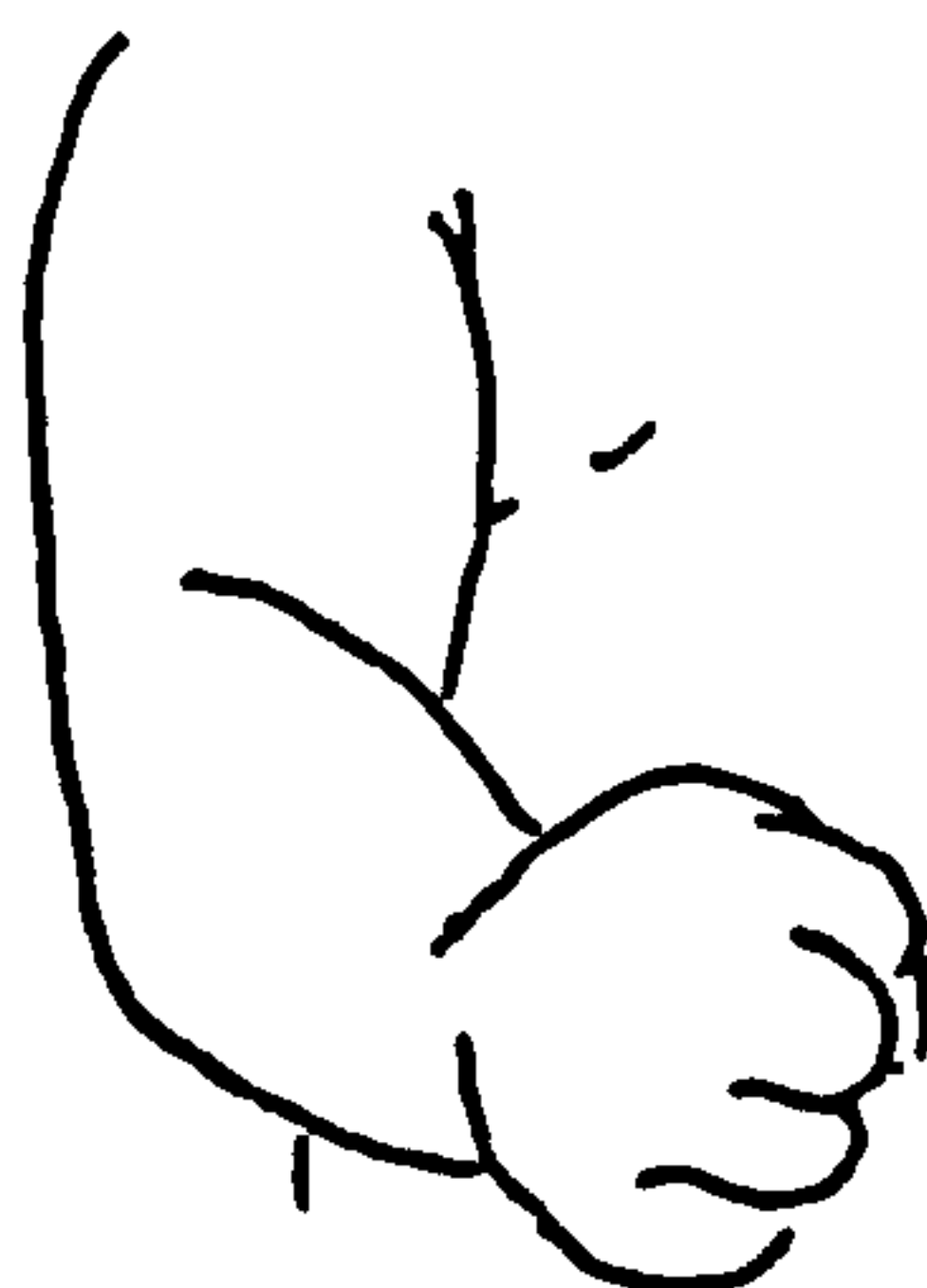

Fig 10.8 The arousal related postures of infant hands
(After Papousek & Papousek 1974)

S.Fraiberg(1974) in her work with mothers of blind babies draws attention to this problem. The absence of gaze monitoring in such pairs in effect puts the mother "in the dark" in her play with her blind infant. Fraiberg noticed that some mothers managed to maintain a far better rapport with their infant's needs. She found that these mothers operated by attending to the child's hands. (See fig 10.8). The therapeutic implications of this observation were very direct and effective and Fraiberg and her team set about drawing the attention of the other mothers to their infants' hands and educated them to be sensitive to the nuances and meanings of their babies' hand dance.

Mary

A particularly effective example of the application of these ideas is given in the case of Mary. She was a normal baby who contracted meningitis at the age of 9 months. Some 14 years later she presented as a completely passive but poignantly beautiful girl. Her limbs were completely floppy and there was no muscle tonus. Consequently, she could not even raise her head. She was diagnosed as being blind and deaf. She was completely mute and her eyes continually and rapidly rolled.

My initial mothering sessions with Mary were very tentative and gentle, but when I became counterintuitively more vigorous in my handling of her, she produced a dramatic increase in muscle tonus.

It was noticeable that activities I engaged in such as

tickling, stroking the lips, singing and rocking, produced a decrease in Mary's eye rotation and I used this as a feedback signal to tell me if Mary was attending to my actions. Novel activities produced this effect but it was noticeable that if an activity was prolonged the eye rolling increased again.

It seemed possible that Mary was not blind but employed eye rolling to maintain a minimal level of sensation in the form of movement in her peripheral vision. When I initiated an activity it provided Mary with an alternative source of stimulation so she no longer needed to generate visual motion. However, when she habituated to a novel stimulus she found it necessary to return to the eye rolling.

Mary's muscle tonus increased during these sessions and the hand behaviour described in Fraiberg's account emerged. With this available as a signal it was possible to have a fairly direct indicator of her arousal level. Intuitively it seemed that at a specific level of arousal (arm approximately 30% of distance between complete flaccidity and spasm) Mary was more inclined to initiate movements. The Mothering activities were modulated to maintain this level as far as possible, after initially more intense episodes when she was swung to and fro.

Through a series of events (which entailed the ward being in quarantine for a month half way through the sessions and eventually Mary being transferred to another hospital) only eight mothering sessions of some 1/2 hour duration were possible.

During these eight sessions the following changes in Mary's abilities were noted.

- 1) Increase in muscle tonus and an associated increase in head control. If she was sat up vertically she could hold her head. If placed on her face she would actively move to one side, whereas previously her head just flopped.
- 2) Occasionally she would grasp my arm.
- 3) On a couple of occasions a smile emerged.
- 4) She began to coo quietly and tentatively.
- 5) Ward staff commented that she began to fuss if she was uncomfortable
- 6) Perhaps most remarkable was the demonstration that she was neither deaf nor blind. When I cooed from one side Mary moved her eyes in the direction of the sound. This was repeated with every coo.

Joyce and James Robertson (personal communication) have obtained similar results by "mothering" a profoundly handicapped boy. Over a period of some six weeks the child that they worked with manifested developmental changes in the order of 4-5 months.

In the examples of mothering presented in this chapter the mothering activity was preceded by a period of exploration which gradually developed into a particular "style" of mothering. The process of getting to know where the child is "at" entails an implicit developmental model, and whereas mothers tend to operate in the here and now, and in effect have no curriculum, it may be useful in contemplating the developmental needs of a profoundly handicapped child to have reference to some structure and fig 10.8 is a provisional and sketchy candidate for such a structure.

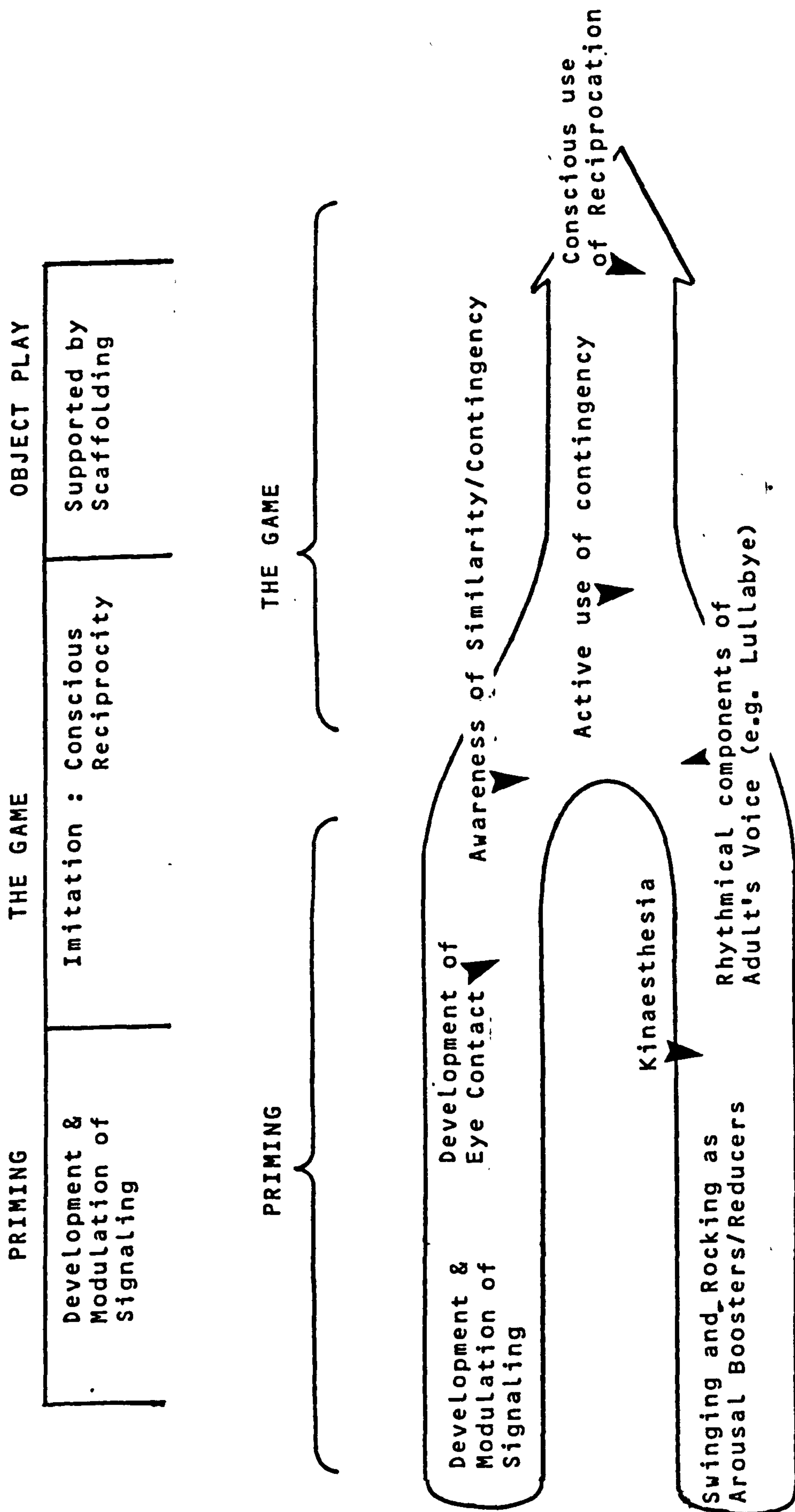

Fig 10.8 Some aspects of early infant development

The further development and application of such a structure would, as with the representation of sensori-motor development, entail the recognition that development is not unilinear and that the principles of horizontal decolage applies here as well.

For instance, of the 5 senses, only sight, sound, and kinaesthesia is considered here. The experience of feeding involves both taste and smell and is excluded from this account, yet they would be a dynamic part of the priming period of development.

The notion of decalage applies inasmuch as although primary, the mother is not the only person to have contact with the infant. As the infant begins to discriminate between people, so strangers, to make contact with the child, appear to follow an abbreviated version of mothering in trying to establish rapport with the child. The stranger who is too enthusiastic will quickly cause the baby distress since he has not attended to baby's initial signals informing him that his actions are taking the baby beyond the informational boundaries within which the baby feels comfortable.

In the area of object play, regression back to earlier mothering games occur in a sense when the child is disturbed and returns to mother for comfort.

Sandler & Sandler (1978) in a discussion of the development of object relations typify infants as wishing and seeking "nourishment" in the form of reassurance and affirmation. The gratification of such desires provides a "background of

safety" from which the infant operates in his developmental endeavours. The seeking of reaffirmation from mother is manifest in situations where mother and toddler may be engaged in independent activity in the same room but continually engage in a subtle "checking up" of each other. When mother leaves the room the infants' need for gratification is highlighted by his anxious or distressed behaviour.

CHAPTER 11

The logic of the material presented so far has drawn attention to the social interactional aspects of control processes fundamental to an open ended and developing cognitive system. Without necessarily proving anything, this formulation has allowed us at least to contemplate the notion of therapy with the profoundly mentally handicapped. In most areas of handicap a distinction is made between the impairment (e.g. chronic bronchitis) and the handicap (e.g. inability to walk any distance). In mental handicap this distinction is not usually made and a child will be described as, say, being visually impaired and being mentally handicapped. The two aspects are seen as being independent. Rarely is the "mental" spoken of as a process leading from impairment to handicap. This, it seems to me, arises from our considerable ignorance about the impairments involved in mental handicap.

In this chapter some possible mechanisms involved in infant development will be discussed as possible loci of impairment. My aim is not to give an exhaustive account but to make tentative suggestions about some of the mechanisms involved in developmental impairment.

Eye contact

Investigations of the nature of infant/mother interactions characterise the dialectic nature of their interplay and present the infant as a system that in isolation is functionally incomplete. Only in the context of his mothers' actions does he

become a viable developing system.

In the clinical examples presented so far the importance of eye contact has been referred to on several occasions. In the case of autistic children it was proposed that they actively practised gaze aversion {See also Creak (1961)}, whilst in contrast, children like Mary, did not know how to look.

Whilst working with Robin, I noticed the occasional eye to eye contact occurred during rocking activities, when he was cradled in my arms and rocked from side to side whilst I was looking into his eye. The following seemed a plausible explanation for this process:

Robin, in rocking his head from side to side generated visual motion in the same manner that Mary did. In so doing he generated peripheral, rather than foveal vision. In the activity of rocking I took on the responsibility for creating this visual motion so Robin no longer had to shake his head. In Mary's case eye rolling was obviated.

Having thus enabled him to hold his eyes steady, what he sees, in the act of being rocked, is a field of motion at the centre of which is focused the adult's eyes. Relative to the surrounding field the image is relatively stationary and coincidentally lies in the area of his fovea. (Fig 11.1) It seemed then that this was the first time that Robin had looked at anything.

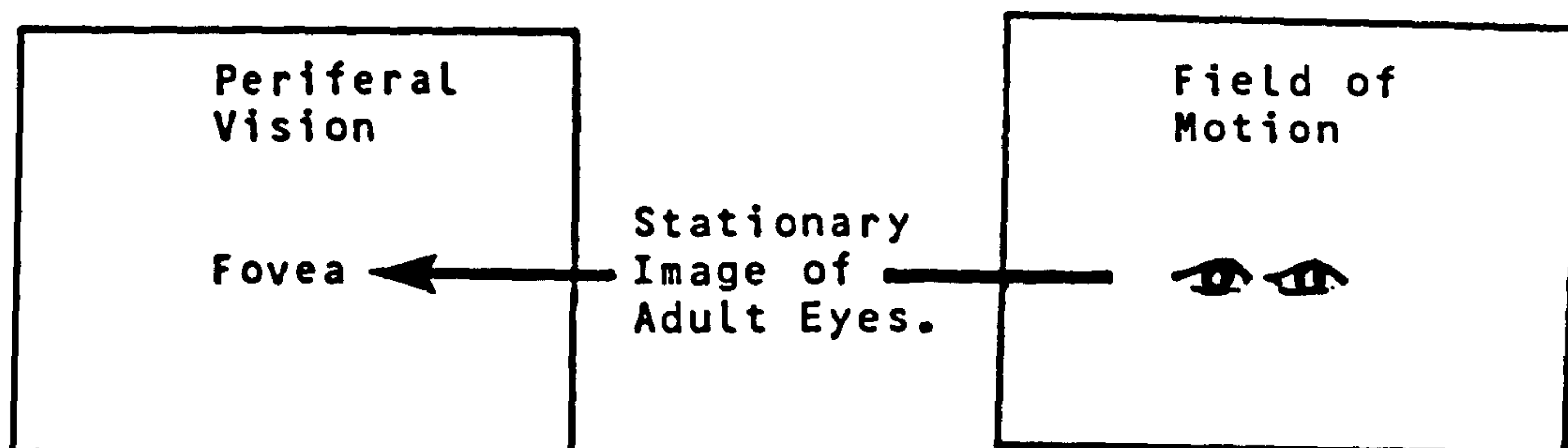

Fig 11.1 The fixation of the "mothers" eyes on the infant's fovea in the act of rocking

An attempt was made to see if the effect was repeatable and another child was sought with the specification that...

- a) he was thought to be blind despite no apparent damage to the eye, and....
- b) that he indulged in either head shaking, or eye rolling.

Ian was a four year old who fulfilled my criteria and I attempted to elicit eye contact by rocking, but after 15 minutes I abandoned the attempt. Further reflection suggested that the issue of optimal arousal/information level was involved. In other words the child chose a particular rate of head rocking to generate an optimal rate of visual motion, thus the rocking rate adopted by the adult was crucial. A second session was attempted with this in mind and I rocked him at various rates whilst I looked into his eyes. In less than one minute, prolonged eye to eye gaze was obtained.

Later sessions involved gaining eye contact then moving my eyes slightly off Ian's gaze. This succeeded in eliciting appropriate eye movement on his part and led to the ability to track a moving object. Further work by his teacher led to this formerly immobile child moving about by wriggling, and eventually developing the basic motions of crawling.

Although such a technique seems to work with the profoundly handicapped child it does not necessarily mean that the same explanation applies to the development of eye contact in the normal infant. Neonates usually take a few days before opening their eyes. However, babies born under a LeBoyer regime, where birth takes place in a dimly lit room, are reported to be born with their eyes open.

Wertheimer (1961) demonstrates some interesting competence in a neonate less than 1 minute after birth. He operated a clicker on each side of the infant's head, and on each occasion the infant's eyes moved in the direction of the sound. This suggests that not only could he locate the source of the sound in space, but that he looked towards the source as if expecting to see something.

Research generally recognises that infants have the ability to fixate upon an object a few weeks before they engage in eye contact with their mother.

It would seem possible that the elicitation of gazing behaviour in children who are unable to fixate is a reversal of the acquisition order of normal infants. However the development

of infant vision is a complex area. Greenberg (1977) suggests that 4 different processes are entailed, he further suggests that researchers are not always clear about which process they are investigating and this results in much conceptual confusion. Greenberg however, does not consider the role of peripheral vision in his conceptualisation.

The elicitation of gazing by rocking does have the quality of biological necessity. We have a situation where,

(1) We have the morphological structuring of the retina into an area developed for the reception and transmission of visually fixated information, surrounded by an area dedicated to a large extent to the reception and transmission of movement.

(2) The natural mothering activity of rocking whilst looking into the infant's eyes having, from the infant's point of view, the same structural form.

(3) In this activity, the eye of the mother is placed at the relatively inflexible focusing distance of the infant's eye.

This is either very fortuitous serendipity, or an example of the very sophisticated functional "designing" that one expects from the evolutionary process.

Another approach to the therapeutic problem of developing visual fixation in the profoundly handicapped and which again raises issues relevant to normal infancy is given in the following case.

Brendan.

Brendan is a hydrocephalic 13 year old who engages in rhythmical to and fro rocking whilst he moves his eyes in a slow and roughly elliptical rolling motion. He often moved his fingers in front of his eyes, smiles, and engages in a delicate finger dance without apparently looking at what he was doing.

I attempted to assess Brendan on the Uzgiris and Hunt scales but failed to elicit any fixation, let alone any ability to track. Despite my firm belief in the Piagetian notion of invariant developmental order, I placed a sweet on the table in front of him, and then placed a screen in front of that. Brendan reached out, knocked the screen out of the way, and obtained the sweet without looking at what he was doing!

I attempted a more sophisticated effort at ascertaining whether he was able to track or not. The following procedure was used.

Brendan was sat at a table and behind him was placed a large mirror. In front of him was set a videocamera. A flashing light held in the camera operators' hand was moved along a square path around the camera. Play back of the video tape showed Brendan's face and the reflection of the flashing light traveling a square path around Brendan's head. Inspection of the tape showed no sign of any correlation between Brendan's eye movements and the movement of the light.

Later reference to T.G.R.Bower's work (1977) suggested a plausible explanation which gave some therapeutic insight.

Bower placed young infants in a cubicle and placed an attractive object for them to grasp. When the infant started to reach for the object he was plunged into darkness. The infant continued to reach for the object. (Bower employed infra red cameras to film his subjects.)

A few weeks later the same infants were unable to perform the same task. It seemed that in acquiring eye-hand coordination it became necessary for them to visually monitor the progress of their hand to the object. This was of course impossible in darkness. It also suggests that these infants, prior to acquiring eye hand coordination, registered the location of the object, computed a trajectory along which to send their hands and then had merely to operate the appropriate hand/arm movement.

This then provides us with an explanation of how Brendan succeeds in retrieving the sweet and suggests how he might be enabled to develop further visual competence.

From his point of view he had a perfectly adequate means of acquiring objects , but he had no experience of reaching for moving objects for which he needed eye hand coordination.

The following procedure was followed. A sweet was placed in front of him, and once he had started reaching for the sweet it was moved a few inches to one side. His hand would then reach for an empty space where he expected to find a sweet. A similar process to the "lettuce leaves in a cup" surprise operates and he notices the sweet alongside his hand.

By thus increasing the displacement of the sweet from its original place, over the period of two weeks we enabled Brendan to acquire the ability to track. Subsequent testing on the Uzgiris and Hunt (visual pursuit and permanence of objects subscale) demonstrated that Brendan could track an object which disappeared behind a screen and persisted in looking at the point of disappearance.

Bower's (1974) work suggests that in some areas of the infant's competence a specific competence may disappear and then later reappear. It seems that although the behaviour is the same the underlying processes which maintain the competence are based on forms of greater flexibility than those supporting the original form of the behaviour.

Bower, Broughton and Moore (1970) demonstrated that infants 6 to 10 days old, reached out in the direction of a visual object. Bruner and Koslowski (1972) studied the same behaviour in an infant at 10 to 22 weeks of age and many of the infants in their sample had not reached satisfactory reaching.

The Uzgiris and Hunt assessment of Brendan suggested that he scored at item 4 when he recovered the sweet from behind the screen, whereas within Piagetian theory he was not even scoring item 1. The discrepancy between Bower et.al.'s and Bruner & Koslowski's findings becomes less of a puzzle if we entertain the notion that different processes result in the same behaviors.

The question that arises is whether the earlier

manifestations of particular competences are functional, or whether they are vestigial functions left behind in the course of phylogeny.

A newborn calf will walk within an hour of birth. The rapid transition from the first staggering attempts to stand to a competent gait later in the same day, suggests that the calf has an innate schema of "how to walk" and the learning process entails fleshing out this schema. The human infant on the other hand learns to walk, very slowly, and his walking is usually preceded by learning to crawl. Infants, however, do have a walking reflex and P. Zelazo (1976) has shown how it is possible to practise the reflex. The baby that he worked with shows some amazingly precocious walking. However the quality of this trained reflex walk is mechanical and lacks the fluid adaptability of normal walking.

In this particular instance the walking reflex is vestigial but other reflexes may be functional. e.g. the rooting reflex, which allows the baby to find the nipple.

The Inculcation of possibility

In chapter 5 it was pointed out that the child's understanding of language was ahead of his ability to speak, and as McNamarra(1972) pointed out, "the child needs to know what he wants to say before he actually can try to say it."

The distinction between "knowing that" and "knowing how" arises in many areas and it may well be that some of the

primitive innate competences may serve to draw the child's attention to "things he can do". Once his attention is drawn thus then he may begin to develop a sensori-motor version of the same competence and so use this as the basis for further elaboration and development. Were such functions to be identified as operating pathologically then it would not be difficult to set up procedures that served as an alternative basis upon which the mentally handicapped child can build upon.

The picture that seems to be emerging from our understanding of infancy is that of the infant possessing these chunks of innate competence which could be classified thus:

- (a) Redundant vestigial competences.
- (b) Independently operating competences.
- (c) Incomplete competences that only function when the other half of the system, viz. mother, is actively present.

These semi systems set up the infant as ready to engage with the social fabric of his environment.

D.S. Lehrman(1953) has commented that from the point of view of evolutionary theory, the cultural system can replace the more stable genetic mechanism as a means of encoding and transmitting adaptive information. The relative instability of culture has the advantage of a much faster response to environmental changes.

The example of the structural compatability of the retina with mother's activity, assuming it applies to normal infants, would be an excellent example of the shift of adaptive responsibility from genetic to social systems. It also suggests

that a useful approach to the study of infant cognition may be to make the assumption that mothers "do everything for a purpose" and then to undertake a functional analysis of mother's activity from the infant's point of view. We might term this approach "maternal ecology".

Other examples of maternal ecology might be singing and rocking as kinaesthetic/auditory integration, whilst at the same time providing diachronic rhythmical structures upon which the infant can overlay knowledge of these modalities.

The interplay between mother's activities and the infant's stimulus/arousal control processes is an example of such a biosocial competence system. The nature of this system's functioning draws our attention to a point, and that is that this particular system does not function in isolation but functionally relates to other systems such as those dealing with smiling, gazing, muscle tonus etc. It may be that this particular system is privileged but it would be wise to be open to the possibility that other systems may interrelate.

In the case of mothers of mentally handicapped children this conceptualisation has important ramifications, for if the baby is "damaged", then the information that he imparts to her is likely to be distorted. Consequently her actions may be inappropriate to a varying extent.

This misinformation may be confounded by social processes. The mother of a child whose language is delayed may through her contacts with other mothers be under pressure to sustain her

child's normality. The resulting pressure on the child, if inappropriate, may seriously exacerbate his condition.

Another process may occur if the infant is born not ready to be fully viable as a partner in the pair. The embryogenic/maturational processes which culminate in this viability may still be in progress but by the time viability is attained, mother will have experienced her infant as a less than responsive member of the dyad and may not be able to complete the dyadic interplay. Such babies miss their cue.

This hypothesised process is comparable to the systemic asynchrony mentioned in the context of the Uzgiris and Hunt scales, only now our concept of system explicitly includes both mother and child.

The therapeutic implications are similar to those mentioned earlier, and in principle would entail recognising the nature of the delayed system and its relationship to other parts. This in turn would entail maintaining the viability of these parts whilst working on promoting the viability of the pathological system.

Further, where a function is damaged it may be possible to reprogram. An example of this is the PECO method, employed to treat adult patients of normal intelligence who have suffered cerebellar damage. The effect of such damage is a lack of control of the limbs, and patients find a simple task like picking up a cup impossible. The PECO method entails a patient "talking" his

or her way through a motor task. E.g. "move my hand forward a bit more, now down a bit..etc." It would seem that language provides the patient with a medium with which the actions are rebuilt and, over a period of time, reasonably normal function can be reattained.

I have employed a similar technique to a limited extent with an athetoid child. In the absence of language, the contingency of my responses to the child's actions was employed, within the context of a game, as a means of drawing the child's conscious attention to her unused arm.

This discussion has been based on some speculative hypotheses about the nature of pathology in mental handicap. Empirical studies of mothers and mentally handicapped infants support the plausibility of some of these speculations. Studies of such pairs (e.g. O.Jones, 1977) suggest that mothers of mentally handicapped infants tend to talk over their babies and the interplay between the two is out of synchrony.. It should be noted that here the term synchrony refers to the entrainment, (taking of turns), between mother and infant. In this text we'll adopt the term dyadic synchrony for this "turn taking" to distinguish it from the idea of systemic synchrony introduced in chapter 6.

Oliver and Davies (1979) undertook a similar study to that of Jones but they found that the mothers and mentally handicapped babies in their sample had better dyadic synchrony than did normal infant and mother dyads. The direct contradiction between

the two studies is intriguing and may be a function of different samples, or different investigative procedures. If we accept both studies at face value then Jones' findings are not surprising if we view the infant as misinforming his mother. However the Oliver and Davies findings poses some interesting problems of interpretation.

One possible interpretation is that Oliver and Davies' mothers are doing their work in an optimal manner and their babies will attain their full, but limited potential. Another, less generous interpretation, would suggest that these mothers are "too good" (c.f. Winnicott's, 1976, concept of the "good enough mother") and their actions leave no work for the infant to do. This interpretation would fit into an "optimal discrepancy" hypothesis (Barker, Lewin, et al., 1956) and would also fit the present work.

If we adopt this position then the reason for this state of affairs is of interest. Very baldly the question asked is "who's to blame?" If we tend to ascribe blame to the mother then we need to ask if she would behave thus with a normal infant. No such comparative study has been done to my knowledge, but it seems most unlikely that the blame lies with mother, rather it would be the case that damaged infants elicit such behaviour from their mothers. Accepting for the moment that mothers of the mentally handicapped are either "too good" or "not good enough" then the same argument would apply to the mothers in Jones' study.

Bearing in mind Sameroff and Chander's formulation of the nature of the dyad as being transactional, (Chapter 1) then the process would proceed along the lines of the "malmodified " mother responding to her infant in a presumably non optimal manner, further malmodifying him... he responds and further malmodifies her actions..etc.

In our account of Judy, an explanation was presented which outlined a process of increasing the child's tolerance of failure and leading to an increasingly open relationship with her world. A reversal of this process would be analagous to the pathological infant-mother process suggested here.

Very cautiously and tentatively it seems that it may be possible to undertake a reversal of this process. Before giving more substance to such a proposal much work needs to be done. The implications are that we can then engage in the early diagnosis of a damaged infant, and engage in an informed and sensitive intervention with the mother/damaged infant dyad.

CHAPTER 12

As was stated in the introduction to this thesis the problems of the severely and profoundly handicapped are generally regarded with unmitigated pessimism by most who ever consider their plight and my intention was to generate some realistic optimism. In pursuing this aim I may be guilty of overstating my case and of including uncautious optimism.

In the previous chapter a regime of early diagnosis of specific functional impairments followed by dyadic therapy to minimise the developmental effects of that impairment was suggested. The notion of early diagnosis entails a great deal more knowledge than we have at present of how to conceptualize what the neonate brings with him with which he sets about understanding his world.

Although therapy and diagnosis are inseparable it is perhaps appropriate to concentrate on the therapeutic aspects since good work in this area will have direct diagnostic implications and from the point of view of mental handicap this work will need to take into account the functional relationship between the persons' biology, his psychology, and his culture.

Such diagnostic work does create some ethical issues which entail considerable caution and judgement in clinical practice. A misdiagnosis of problems in an infant will create unnecessary anguish and anxiety and may even contribute significantly to altering the subtle balance of a formerly healthy infant/mother dyad. It may be the case that a premature diagnosis will disrupt

and interfere with a therapeutic dyad whereby there may be some problems with the baby but the quality of mothering is such as to lessen the baby's pathology. A premature intervention may handicap the mothers' potential for therapy. (A similar issue is raised by Stern (1977)).

In areas of mental handicapp as those addressed by this thesis it would seem that diagnosis without therapy should be avoided and the therapeutic aspects of research should have priority over the diagnostic aspects.

Assuming knowledge of therapeutic process and a well worked out diagnostic regime, the parent's relationship to such knowledge needs to be understood. It seems that the experience of most parents of mentally handicapped children is of professionals not informing them of their child's condition, and these parents bitterly resent not having been told that their child is mentally handicapped. Yet in the one or two cases I have heard anecdotally (J.Foyle, personal communication) of parents responding with understandable anger and withdrawal on hearing of their child's condition. In these cases further support and therapy for the child was no longer accepted from the informant by the parents.

It is clear from some of the cases that I have presented that the simple act of mothering does produce some relatively dramatic changes in some institutionalised mentally handicapped children, but let me add a cautionary postscript to the account of Judy. (page 138).

Some of the sessions with Judy were recorded on video tape. Her parents were invited to view the tape. On seeing their daughter they were delighted, and commented how nice it was to see her so happy, just like she used to be at home! It seemed that the withdrawn Judy was a function of the institution and prior to admission she was a happy, boistrous, but destructive and unmanageable child.

Whilst this takes away some of the punch from the presentation let me add that the imitation procedure has enabled many a-social children to begin to take on and enjoy social play with an accompanying increase in outgoingness.

This raises a rather circular point. In the large hospital for the mentally handicapped, workers with a therapeutic outlook often wonder to what extent they are dealing with the effects of the institution rather than with the effects of the condition of mental handicap. It may be salient to point out that some superficially more benign hostel may be more institutionalising than the large victorian "bin", and some families may be similarly powerful agents of the institutionalising process.

If we regard it as a process then we may discern degrees of institutionalisation and any practice which deviates from ideal mothering may be regarded as such.

This idea of deviation from "good enough" mothering corresponds to King, Raynes, and Tizard's (1971) categorisation of institutions into child orientated or institution orientated. They suggested that the mechanisms which enable a place to be

child orientated entailed a fairly democratic staff structure within which responsibility rather than concrete jobs were delegated. This had the effect of better staff morale, and created and enabled opportunities to relate appropriately with the residents. One effect of this was a considerable superiority of the language levels of the children in the child orientated setting.

Deviations from the activity of "ideal mothering" are bipolar. Some wards may administer a rigid and insensitive regime which demands administratively convenient behaviour from its inmates. At the other extreme, wards may function in a very caring manner but by making no demands and expecting no change, may be equally institutionalising.

The developmental effects of "good enough" mothering are constrained by the nature of the child's handicap. In the previous chapter the possibility of therapeutic mothering was entertained which related not just to the child's expressed needs but fundamentally to his means of expressing needs. The degree to which this may be possible will depend on the functional nature of the handicap. It may well be the case that some handicapping functions may be beyond the influence of therapeutic mothering.

For instance there is the possibility that some intellectual aspects of mental handicap may arise simply from the speed of neural transmission. This may be modifiable via arousal functions by therapeutic mothering, but there may be bounds on such modifiability, and to go further it may be necessary to go into

the biochemistry of neural transmission.

If we accept the plausibility of therapeutic mothering, we still do not know the limits on its effects. In some children it may be far reaching, and in others minimal.

Another cautionary possibility exists. Even as it is understood now, the nature of the infant mother transaction is complex and subtle and a complete mapping of the processes is likely to unfold a scene of considerable complexity. It may be so complex that the effort required to engage in therapeutic mothering may be daunting. To overcome this possibility it might be necessary to chunk the components of the process into more manageable units.

A similar dilemma arises in the operant approach to language acquisition which ignores current understanding of mothers' role in the acquisitional process of the normal infant. Whereas, in terms of acquiring specific words the method produces good results, these results rarely generalise in a fundamental way, and the operant therapist has to contemplate the impossible task of teaching the whole language bit by bit, and as Chomsky and Miller calculated, this process would take millienna.

The alternatives would seem to be either to decide on an economical and realistic subset of the language, or to ambitiously shift ones focus and look at the possibility of working on the acquisition process itself.

So if therapeutic mothering is confronted with the same

dilemma it may need to focus on a subset of the total system, but optimistically it seems likely that these subsets are not closed systems but are influenced by changes in other subsets of the infant system. Given understanding of their interrelationship we might contemplate the possibility that work on a specific dysfunction will ramify throughout the whole system

Affect and intelligence

Two aphorisms operate in our culture

(a) Nothing succeeds like success.

(b) You only learn from your mistakes.

These apparently contradictory statements seem both essentially true and if we regard the first as relating to the affective aspects of learning, and the second as relating to cognitive aspects, then the contradiction changes to a contrast.

In the account presented here the two aspects go hand in hand and are inseparable. The formulation bears a close similarity to Bowlby's (1969) ideas of attachment.

The learning infant is seen as operating from within a field of secure predictable knowns from which he takes on appropriately limited but less predictable elements from beyond his secure field. (Sandler & Sandler, 1978) The security of this field though, is intrinsically linked to the infant's experience of success. If success fades then the child can no longer take his field of security for granted and has to check up on elements of the system. If this activity meets with limited success, then the infant, (or even the adult) will devote much effort into

maintaining the system. In cases where failure is met the boundaries of security will recede.

In considering the problems of mentally handicapped people, emotional problems are very often ignored and they are typified purely in terms of intellectual problems. The mentally handicapped child is usually perceived exclusively in terms of his handicap and only rarely is he perceived as a child in his own right. This perception allows such children to be brought up under conditions that would create a national scandal were they perceived as children.

Typically the issues are not so clear cut. A large bare ward with limited furnishings is sometimes a better environment for a disruptive and anxiously aggressive adolescent than a nicely furnished domestic setting. In the latter case any sign of an impending outburst will create anxiety about property in those responsible for care on the ward, and this anxiety will contribute to, and grossly exacerbate the child's outburst. In the barren ward, anxieties about property are minimal and the child's disruptive behaviour may disappear, not because of coercion, but because of the absence of staff anxieties. Staff on such wards may be able to provide sensitive opportunities for the child to begin to relate, but all too often the regime of such wards makes such developments extremely unlikely, and a child in such a regime is more likely to be seen as attention seeking rather than as needing affection and extending his surroundings.

The perception of someone as mentally handicapped, rather

than as a child (or adult) seems to reflect some confusion in the area of child development generally and this confusion stems from the relationship between the variable and invariable components of development.

In chapter 5 it was pointed out that a mentally handicapped child described within the framework of the Uzgiris and Hunt scales was indistinguishable from the normal infant. Where differences did emerge it was in the manner of transition from one cognitive structure to the next. Piagets' structural theory is not intended for looking at individual features, such as personality, cognitive style, etc. The theory aims, and to a fair extent, succeeds in abstracting the invariants of development. This invariance is a function of the interplay between the physical/functional invariants of the human species and invariant structures in the environment. Rosch(1974) for instance, argues that human categories are as they are because they reflect the nature of the world rather than the species. To talk about individual differences we must, against a background of invariants, contemplate the variants of the system. The environmental variants would be culturally conditioned. Within the subsystem of any culture there are both invariant aspects, (e.g. the language system) and variant aspects, (e.g. mother's personality). Species variance may be manifest as different constitutions, temperaments, etc.

There are cases though when the invariants may vary with concomitant implications for development. The development of

object permanence in a blind infant would be an example of such variant instability.

The implications of changing the nature of environmental invariance can be seen if, for example, we contemplate the developmental implications of an infant reared under conditions of zero gravity. The changes in spatial and causal relationships might produce a world view that gravity bound intellects might find difficult to comprehend.

In the case of blind infants we have a variation in what is normally taken for granted. To share the world view of a blind person is extremely difficult and can only be done in an abstract intellectual way. We may don a blindfold and become more aware of sounds, smells, etc. but our relationship to these modalities differs from those of a person blind from birth since he has had a lifetime constructing the world in these modalities. Consequently he has strategies and structures appropriately negotiated with his world. Even if we were to commit ourselves to a prolonged period of being blindfolded there is no guarantee that we would eventually acquire the world view of the blind person, for we have available a structural understanding based on a largely visual modality, and this would be available to help us organise "blind" perceptions. The person born blind does seem to be different from one who has lost his sight.

Yet, even though it may be difficult to empathise with the blind person we can identify the cause of the difference in world view, and the very act of identification gives us a direction in

which we may begin to empathise.

In the case of mentally handicapped people we again have an instability in species invariance, but in this case our ignorance about the nature of the difference between them and us precludes the possibility of empathy. The result seems to be that we adopt a view of the "mentally handicapped" as a different species and the norms and expectations that we normally apply to our kind rarely apply to this other "species".

If we do attempt to identify the differences, the most apparent is that in intellectual ability and this gives us a metonymic coding such that we do not need to unpack the other attributes of that person.

It is very salutary to attempt to role play a mentally handicapped person being taught a simple task such as putting a coat on. My first attempts in such a session resulted in a contrary and uncooperative act, but the role was that of a relatively bright person. With practise though it became possible to recognise those areas of competence that I normally took for granted. The role playing is rather intellectual and contrived, but it is salutary to recognise for instance, that someone pointing and uttering something incomprehensible, causes me to look at his finger, and not at the coat button which I was required to fasten.

Trying to make sense of such data is bewildering and may induce various emotions including anxiety or even anger. The experience is not purely intellectual.

As a theory, BABEL begins with the invariants of human development and draws heavily on piagetian formulations, but with an emphasis, not so much on the structural theory but on the processes that are postulated to underly the transformation from one structure to the other. The emphasis on transformations does not in itself move the discussion from the domain of the invariants of development to that of the variants, but by attempting to specify unambiguously the mechanics of the theory, areas of discretion are revealed which promise to modulate various versions of the invariant theory into variant theory. It is perhaps not suprising that these gross modulations have some validity in application to mental handicap, and finer modulations may begin to refer to more normal individual variants.

So for instance, in formulating BABEL, the realisation came that a coded episode including an action did not necessarily entail that that action was operated when that chunk was addressed. In terms of a theory of developmental invariance, such discretion was necessary to allow the system to reflect upon a situation rather than impetuously operating a response conditioned to the stimulus. Having recognised the area of discretion and built a choice into the system, questions then arose as to the parameters of the choice, such that we might have various versions of the system with different propensities to act or not.

At an extreme, versions of these parameters could be linked

to conditions such as hyperactivity or extreme passivity, but within these extremes there are viable variations.

This would be in accord with Escalona's (1968) work on the developmental implications of temperamental differences in infants. This moves the theory into the area of variance and may give it potential as a theory of personality, cognitive style, etc. So the action/inaction parameter might relate to the dimensions introversion/extraversion and theories of the locus of control.

The story however is not so simple and both in its own history and in its presentation BABEL has become increasingly transactional. In discussing levels of variants then it is necessary to recognise that explanations of developmental variance must entail the dialectic between species and environmental variance against the background of the dialectic of the invariants of both systems.

Understanding mental handicap then entails understanding its dialectical nature which is a facet of the fascinating interplay between the organic and the cultural.

When I began this work I fondly imagined that I would end up with some answers about mental handicap. At this point in time I realise that I have reached far short of that aim and have ended up with a way of thinking about mental handicap, a wide range of questions, and little that claims to be an answer.

In response to this realisation I would claim that I have shown it is plausible to be optimistic about the problems of the mentally handicapped and I would like to think that the questions I have raised have been along potentially useful lines both in terms of theory and therapy.

However I am confident enough to think that the questions raised are important and worthy of consideration if only because of their implied optimism. However, it is rash to swallow a theory wholesale just because of its optimism: we need to countenance it's veracity. Yet I feel that proof of a theory as general as that explored here is impossible, for that would entail omniscience. Such a theory can only be judged in terms of the extent to which it is plausible and useful, and that judgement needs to take into account the historical and cultural context in which the theory is offered.

It would seem that BABEL is only as useful as it is plausible for if it is implausible, then I have raised false hopes. How the plausibility of this work is evaluated will no doubt reflect the particular criterion of each reader. Whilst respecting the reader's right to impose his own criterion, I would like to raise some aspects which lead to my own evaluation of the theories plausibility. Also I would like to make clear the boundaries of my claims so that evaluation is fair to the theory.

In earlier chapters I have taken some pains to typify the theory as a model. Many people mean many things by the term model and confusion often arises when various interpretations of the

word are used

BABEL attempts to provide a general theory of processes underlying the development of normal and mentally handicapped children. I use the word general in a particular way and do not imply that it explains everything. By general I mean that I assume that a common process exists in developmental change regardless of what point in a child's development a change is observed. It is also general inasmuch as it assumes that at a particular level of abstraction the same process occurs in both normal and in mentally handicapped children. This level of generality is intentional and the notion of specific procedures was avoided. In looking at the transition from nonreflective to reflective action in the child operating at Piaget's stage 5, it was tempting to build in a procedure along the lines of..

IF APPROACHING STAGE 5, GO REFLECTIVE, ELSE REMAIN IMPULSIVE

In the account of the sensori-motor field it was suggested that specific functions such as crawling, smiling, etc. might arise as a result of maturational processes. But even if such a possibility exists, to build them into the model as specific procedures would preempt the possibility that they arise out of the operation of the general process.

In typifying BABEL's structure as chunks of embedded lists it was tempting to invoke the magic number 7 and structure the lists accordingly. The decision to ignore the number 7 was deliberate and the possibility was entertained that the workings of the general process might generate it. So far "7" has not come to light, but a possible source might be in the interplay between

BABEL's processing speed and the environmental rate of change. Until quantifications are entered into the model, no numbers will emerge from it.

Such decisions are not arbitrary, but are partially motivated by a need to be optimistic. Given a choice of two possible explanations where the available evidence does not discriminate between the two it is possibly appropriate for the therapist to opt for the most optimistic version.

The bias goes further, for in cases where an explanation involving concepts such as capacity are suggested, a pessimistic intractability is implied about the condition of the person of limited capacity. This imposes constraints on the therapist for of course you can't put in "what God left out". However if the opportunity arises for a different understanding of capacity as process which allows for modification, then the therapist needs to pursuit such possibilities. Furthermore he must be on the look out to creat such possibilities especially when the pessimistic alternative is based on untested assumption, even though it may be conventional wisdom.

BABEL then is a healthily biased general theory of development which sets out to create therapeutic possibilities. It does not however claim to be a complete general theory, either in the sense of explaining everything or being completely worked out within its own boundaries. Even though the theory is presented as an explanation its usefulness may perhaps be better judged as a medium for thinking with and for raising questions.

Although BABEL is not a complete theory, that does not imply that it will not explain more than it does in this presentation. BABEL is argument by analogy and analogies can be stretched too far. "Stretching an analogy" can be a very useful and valid method of inquiry. In the process of stretching various anomalies arise which just do not fit. In the case of BABEL it is easy to produce instances of human performance with which the theory does not cope. In contemplating exceptions we are not left just with a list of unaccountable phenomena as sometimes the contrast between these phenomena and the overstretched theory indicates a possible direction in which an alternative direction might take. This might develop into a very well worked out theory which covers many of the aspects of the original theory, and many more, but it is likely that some aspects covered by the first theory are not considered by the second. A synthesis of both theories would lead to a third position and this would have strengths as well as omissions... and so on.

Thus typified, the work of an investigator needs to be understood and evaluated, not in terms of a static structure presented as a theory but as a process of which the investigator is part. This view of investigative activity essentially follows that of Kuhn (1962), typifying science as operating at a given period in its history, within a paradigm (qua analogy) and operating what he terms "normal science". This entails building up evidence in support of the current paradigm. A point is reached where the current paradigm becomes inadequate, a revolution ensues in which, usually younger scientists are

involved, and a new paradigm emerges with an associated change of perceptions. The fact finding process of normal science then gets under way again ..etc. Whatever Kuhn's intentions were in presenting his theory, it is usually taken to be a description of how science progresses rather than a prescription for how it should proceed. The possibility of interpreting Kuhn prescriptively has considerable attractions and would lead to much less effort being expended in defending ones position. As I write this I am struck by the analogy between the entrenched style of paradigmatic science and the style of the autistic child!

Having presented the idea of a Kuhnian prescription I am reluctant to admit to an inconsistency in my own position, inasmuch as I recognise that I am working within a psychological paradigm that might be grandly labelled "transactional constructivism" and from this position I am critical of intolerant other positions. Within this framework, however, I have been engaged not so much in a fact finding enterprise but in a process of changing ideas, perceptions and questions. So judgement and plausibility need to take into account, not just the formulations presented but the means by which these formulations were arrived at and their likely therapeutic implications.

REFERENCES

AINSWORTH M.D.S., BELL S.M., and STAYTON D.J., (1971) 'Individual differences in strange-situation behaviour of one year olds', in H.R.Schaffer (ed.) The origins of human social relations. Academic press, London & New York

ANDERSON J.R. & BOWER G.H (1973) 'Human Associative Memory'. Winston/Halstead Press, Wiley, N.Y.

ARIETI S. (1974) 'An overview of schizophrenia from a predominantly psychological approach', American Journal of Psychiatry, 131, 241-249

BARTLETT F.C. (1932) 'Remembering'. Cam. Univ. Press.

BATES M.E. (1976) 'Language and Context. The Aquisition of Pragmatics'. Academic Press. N.Y.

BAYLEY (1965) 'Comparisons of Mental and Motor test scores for ages 1 through 15 Months by Sex, Birth Order & Race, Geographical Location and Education of Parents' Child Dev. 36. 379-411.

BERG W.K. (1974) 'Cardiac Orienting Responses of 8 & 12 Week old infants.' Journal Of Experimental Child Psychology. 17, 303-12.

BERKO-GLEASON J. (1973) 'Code Switching in Children's Language' in T.E.Moore (Ed.) 'Cognitive Development and the Acquisition of Language.' Academic Press, N.Y.

BETTELHEIM B. (1967) 'The Empty Fortress: Infantile Autism and the Birth of Self'. N.Y. Free Press, Lond. Collier McMillan.

BEVER T.G. (1970) 'The Cognitive Basis for Linguistic Structures' in J.R.Hayes (Ed.) 'Cognition and the Development of Language' J.Wiley & Sons. N.Y.

BOWER T.G.R. (1974) 'Development in infancy' Freedman and co. San Francisco & London.

BOWER T.G.R. (1977) 'A primer of infant development' Freedman and co. San Fransisco & London.

BOWER T.G.R. , BROUGHTON J.M. , AND MOORE M.K. (1970) 'Demonstration of intention in the reaching behaviour of neonate humans' Nature,228,No 5272.

BOWLBY J. (1969) 'Attachment and Loss' Vol 1. Attachment. Hogarth Press. London

BRAZELTON, KOWSLOWSKI, AND MAIN (1974) 'The Origins of Reciprocity: the Early Infant-Mother Interaction.' in Lewis & Rosenblum (Eds.) 'The Effects of the Infant on its Caregiver.' Wiley, London

BROWN R. (1973) 'A First Language: the Early Stages.' Harvard U.P., Cam. Mass.

BRUNER J.S. (1972) 'The Nature and Uses of Immaturity' Am Psychologist. Aug. Vol.27(8),687-703.

BRUNER J.S.(1975) 'The Ontogenesis of Speech Acts' J.of Child Lang. 2,1-19.

BUCHER B. & LOVAAS O.I. (1968) 'Use of Aversive Stimulation in Behaviour Modification'. In Jones M.R. (Ed) Miami Symposium on the Prediction of Behaviour. Univ. of Miami Press. Coral Gables, Flo.

CAMERON.J., KITSON N., & BAYLEY N. (1967 'Infant Vocalisation and Their Relationship to Mature Intelligence'. Science. 157.331

CANTOR G.N. (1961) 'Some issues involved in Category, review of the A.A.M.D. Terminology and Classification Manual' Am. J. Ment. Defic.;65,561-6.

CHOMSKY N. & MILLER G.A. (1963) 'Introduction to the Formal Analysis of Natural Languages' in R.Luce & E.Gallanter (Eds.) Handbook of Mathematical Psychology. Wiley, N.Y.

CHURCHILL J. (1971)'The Effects of Success and Failure in Psychotic Children' Arch. Gen. Psychiatry. 25:208-214.

CLARK E.V. (1974) 'Some Aspects of the Cognitive Basis of First Language Acquisition'. In R.C.Schiefelbusch & L.L.Lloyd (Eds.). 'Language perspectives-Aquisition, Retardation & Intervention' University Park Press, Baltimore.

CONDON W.S. & SANDER L.W. (1974) ' Neonate Movement is Synchronised with Adult Speech,' Science, New York. 183, 99-101.

CREAK M. et al. (1961) 'The Schizophrenic Syndrom in Children'. Lancet 2.818.

D.H.S.S., 'Better Services for the Mentally Handicapped '. Cmd.4683 (H.M.S.O,1971)

DOUGLAS.M. (1970) 'Purity and Danger'. Penguin Press, Harmondsworth.

DUNST C.J. (1980) 'A Clinical & Educational manual for use with the Uzgiris & Hunt Scales of Infant Psychological Development'. Univ. Par. Press. Baltimore

ELLIS H.J. (1973) 'Why People Play'. Prentice-Hall.

EMANUEL & WEIR (1976) 'Therapy with an autistic boy in a logo-like environment' A.S.I.B. Summer Conference Proceedings. Edinburgh University.

ESCALLONA S.K. (1968) 'The Roots of Individuality; Normal Patterns of Development in Infancy' Aldine Pub. Co. Chicago.

FAGAN. G. (1976) 'Modelling How and Why Play Works' In J.s.Bruner, A.Jolly, & K.Sylva 'Play; its' Role in Development and Evolution.' Penguin Press, Harmondsworth.'

FERGUSON C.A. (1964) 'Baby Talk in Six Languages' in J.Gumpberg & D.Hymes (Eds.) 'The Ethnography of Communication'.

FERNALD.E (1912) Paper presented to the Massachusetts Med. Soc. Originally Quoted by Sarason and Doris (1969) 'Psychological problems in Mental Deficiency'(4th. Ed.) Harper and Row, N.Y.

FODOR J. (1968) 'Psychological Explanations: An Introduction to the Philosophy of Psychology' Random House, N.Y.

FRAIBERG S. (1974) 'Blind Infants and their Mothers: An examination of the Sign System.' in Lewis & Rosenblum (Eds.) 'The Effect of the Infant on it's Caregiver'. Wiley, London.

GLUCKSBERG S. & DANKS J.H. (1975) 'Experimental Psycholinguistics: An Introduction.' J.Wiley, Lond.

GOLDBERG L.D. (1970) 'Man versus Models of Man, A rationale, plus some evidence, for a model for improving clinical inference' Psy.Bul, 73, 442-432.

GRIFFITHS R. (1954) 'The Abilities of Babies' Univ. of Lond. Press.

FILMORE C.J. 'The Case for Case'. In Bach E. & Harms R.G. (Eds.) Universals in Linguistic Theory. Holt, New York.

HEBB D.O. (1949) 'The Organisation of Behaviour' Wiley, New York.

HONZIK M.P. (1957) 'Developmental Studies of Parent Child Resemblances in Intelligence', Child.Dev. 28:215

HONZIK M.P., HUTCHINS J.J., & BURNIP S.R., (1965) 'Birth Record Assessments and Test Performance at Eight months.' Am.J.of Diseases in Children. 109:416

HUMPHREYS P.C. (1981) 'Decision Aids: Aiding Decisions' In Sjoberg E., Tyszka T. & Wile J.A.(Eds.) 'Decision Analyses, & Decision Process' Vol.1. Lond. Doxa.

HUNT J McV. (1965) ' Intrinsic Motivation and it's Role in Psychological Development' In D.Levine (Ed.) Nebraska Symposium on Motivation. Pp 189-282.

HUNT J. McV. & UZGIRIS I. (1964) 'Cathexis from Recognition Familiarity: an Exploratory Study' Paper presented at the 1964 Convention of the American Psychological Association.

JAKOBSON R. (1968) 'Child Language, Aphasia, and Phonological Universals' Mouton, The Hague.

JAY P.:Chairman (1979) 'Report of the Committee of Inquiry into Mental Handicap Nursing and Care' Cmnd. 7468. H.M.S.O.

JONES O.H.M. (1977) 'Mother-Child Communication with Pre-Linguistic Down's Syndrome and Normal Infants' in H.R.Schaffer 'Studies in Infant Mother Interaction' Academic Press. London, New York.

KAMIN L.J. (1977) 'The Science and politics of I.Q.' Penguin, Harmondsworth

KAUFMAN B. (1976) 'To Love is to be Happy With'. Souvenir Press (E&A) Ltd. Lond.

KARHILOFF-SHITH A. INHELDER B. & BOVET (1974) 'If You Want To Get Ahead Get A Theory' Cognition 3(3) 195-212.

KARRER R. (1976) 'The Developmental Psychophysiology of Mental Retardation: Concepts and Studies'. Charles C. Thomas. Springfield Ill.

KELLEY G.A. (1955) 'The Psychology of Personal Constructs'.Morton, N.Y.

KING R.D., RAYNES N.V., & TIZARD J. (1971)'Patterns of Residential Care' R.K.P. London

KOHLER (1925) 'The Mentality of Apes'. Routledge & Kegan Paul. Lond.

KUHN.T. (1962) 'The Structure Of Scientific Revolutions.' Univ. Of Chicago Press, Chicago.

KUSHLIK A. (1968) 'Social Problems in Mental Subnormality' in Miller E. (Ed.) 'Foundations of Child Psychiatry' Pergamon, Oxford.

KUSHLICK A. & BLUNDEN R.(1974) 'The Epidemiology of Mental Subnormality' in CLARK A.M. & CLARK A.D.B. (Eds.)'Mental Deficiency, The Changing Outlook'. 3rd. Ed. Methuen, London

LACAN J. (1977a.) 'The Insistence of the Letter in the Unconscious' in J.Lacan . 'Ecrits'. Tavistock, Lond.

LACAN J. (1977b.) 'The Subversion of the Subject and the Dialectics of Desire' in J.Lacan. 'Ecrits'. Tavistock, Lond.

LEHRMAN D.S. (1953) 'A Critique of Konrad Lorenz' Theory of Instinctive Behaviour' The Quarterly Rev. of Biol. 28,337-363.

LENNENBERG E.H. (1967) 'The Biological Foundations of Language'. J. Wiley & sons. N.Y.

LIEBERMAN A.M., COOPER F., SHANKWEILER D., & STUDDERT-KENNEDY M., (1967) 'The Perception of the Speech code' Psy. Rev. 74. 431-459

McCALL R.B. (1976) 'Towards an Epigenetic Conception of Mental Development in the First Years of Life'. in M.Lewis (Ed.) 'Origins of Intelligence' Plenum Press.

McCALL R.B., HOGARTY P.S., & HURLBURST N., (1972) 'Transitions in Infant Sensory Motor Development and the Prediction of Childhood I.Q.' American Psychologist. 27:728

McCLELLAND D.C., ATKINSON J.W., CLARK R.A., & LOWELL E.L., (1953) 'The Achievement Motive' Appleton-Century-Croft. New York

McNEMARRA J. (1972) 'The Cognitive Basis for Language Learning in Infants' Psy.Rev.79,1-13.

MILLER G.A. GALLANTER G. & PRIBRAM K. (1960) 'Plans and the Structure of Behaviour' Holt. N.Y.

Ministry of Education (1963) 'Half Our Future: A report of the Central Advisory Council for Education in England' H.M.S.O. London.

NEISSER U. (1967) 'Cognitive Psychology' Appleton Century Croft, N.Y.

NEISSER U. (1978) 'Cognition and reality: Principles and Implications of Cognitive Psychology.' W.H.Freeman, N.Y.

NELSON K. (1973) 'Structure and Strategy in Learning to Talk.' Monog. for the Society for Research in Child Development. 38. (Serial No. 149)

NICHOLS P.L. & BROMAN S.H. (1974) 'Familial Resemblances in Infant Mental Development' Dev. Psych. 10:442

OETINGER (1969) 'Run, Computer, Run; The Mythology of Educational Innovation.

CLERON P. (1953) 'Conceptual Thinking of the Deaf' Amer. Annals of the Deaf. 98. 304-310.

OLIVER B. & DAVIES H.M. (1979) 'A Comparison of the Maternal Speech Environment of Mentally Handicapped and Normal Children. Unpublished M.S. City of London Polytechnic.

PAPOUSEK H. & PAPOUSEK M. (1977) 'Mothering and the Cognitive Head-Start: Psychobiological Considerations' in H.R.Schaffer (Ed) Studies in Infant Mother Interaction. Academic Press, London, New York.

PAULBY S.J. (1977) 'Imitative Interaction' in H.R.Schaffer (Ed) Studies in Infant Mother Interaction. Academic Press, London, New York.

PRIBRAM K. (1971) 'Languages of the Brain' Prentice Hall, New Jersey.

PIAGET. J. (1950) 'The Psychology of Intelligence'. Harcourt Brace, N.Y.

PIAGET J. (1952) 'The Origins of intelligence in Children' Int. Univ. Press. N.Y.

REYNELL J.K. (1969) Test Manual; Reynell Developmental Language Scales, Experimental Edition. N.F.E.R. Lond.

ROSCH E. (1973) 'Internal Structure of Perceptual and Semantic Categories'. in T.E.Moore (Ed.) 'Cognitive Development and the Aquisition of Language'. Academic Press. N.Y.

ROSCH E. (1974) 'Linguistic Relativity' in A. Silverstein (Ed) 'Human Communication: Theoretical Perspectives'. Halstead Press. N.Y.

RYAN J. c. THOMAS F. (1980) 'The Politics of Mental Handicap'. Penguin, Harmondsworth.

SAMEROFF A.J., & CHANDLER M.J. (1975) 'Reproductive Risks and the Continuum of Caretaking Casualty.' In F.D. Horowitz, M. Hetherington, S. Scarr-Salatapek, & G. Siegel (Eds.) Review of Child Development Research. Vol 4. Univ. of Chicago. Press.

SANDLER J. & SANDLER A.M. (1978) "On the Development of Object Relations and Affects." Int. J. Psychoanalysis, 59, 285-296.

SCARR-SALATAPEK S. (1976) 'Genetic Determinants of Infant Development: an overstated case.' in L.P. Lipsitt (Ed.) Developmental Psychobiology: the Significance of Infancy. Laurence Earlbaum Ass. N.Jersey.

SCHULTZ G. (1969) 'Sensory Restrictions' J.Wiley. London, New York.

SKINNER B.F. (1957) 'Verbal Behaviour' Methuen, Lond.

SLOAN R.B. STAPLES F.R. CRISTOL A.H. YORKSON H.J. WHIPPLE K. (1975) 'Psychotherapy versus Behaviour Therapy.' Harvard Univ. Press. Cambridge. Mass.

SLOBIN D. (1973) 'Cognitive Prerequisites for the Acquisition of Grammar' in C.A. Ferguson & D. Slobin (Eds.) 'Studies of Child Language Development'. Holt, Reinhart & Winston. N.Y.

SMITH, SHOBAN, & RIPPS L.J. (1974) 'Structure and Process in Semantic Memory: A Featural Model for Semantic Decisions' Psy. Rev. 81. 214-241.

STAATS A.W. (1968) 'Language, Learning, and Cognition' N.Y. Holt Reinhart and Winston.

STERN D. (1977) 'The First Relationship: Infant and Mother' Fontana/Open Books, London

TREVARTHEN C.(1974) 'Conversations with a two-month old' New Scientist.

TURING A. (1950) 'Computing Machinery and Intelligence'. Mind LIX. 443-460.

TEVERSKY A. & KAHNEMAN D. (1979) 'Causal Schemata in Judgements Under Uncertainty', in Fishbein M.(Ed.) 'Progress in Social Psychology' Hillsdale N.J. Laurence Earlbaum.

UZGIRIS I.C. & HUNT J. McV. (1975) 'Assesment in Infancy: Ordinal Scales of Psychological Development.' Univ.of Illinois Press, Urbana, Ill.

WERTHEIMER M. (1961) 'Psychomotor Coordination of Auditory Visual Space at Birth.' Science 134, 1692.

WINNICOTT D. (1976) 'The Maturational Process and the Facilitating Environment'. Hogarth. Lond.

WATSON J. (1976) 'Smiling, Cooing, and the Game' in Bruner J.S., Jolly A., & Sylva K. 'Play. it's Role In Development and Evolution.' Penguin, Harmonsworth.

YULE B. & BERGER H. (1975) 'Communication, Language, & Behaviour Modification'. in C.Kiernan & B. Woodford (Eds.) 'Behaviour Modification with the Severly Retarded' Elsevier. North Holland.

ZELAZO P. (1976) 'From Reflexive to Instrumental Behaviour' in L. Lipsit (Ed.) 'Developmental Psychobiology- The Significance of Infancy.' Laurence Earlbaum Ass. N.Y.

UZGIRIS & HUNT SCALE

Scale I

The development of visual pursuit and the permanence of objects.

Item 1. Following a slowly moving object through 180° arc.

Administration

An object likely to be attractive to the child is employed. Using an object that the child is playing with is usually successful. The object is passed slowly from, say, left to right, in a horizontal path about 18" from the child's eyes. His eye movements are observed. This may be repeated several times.

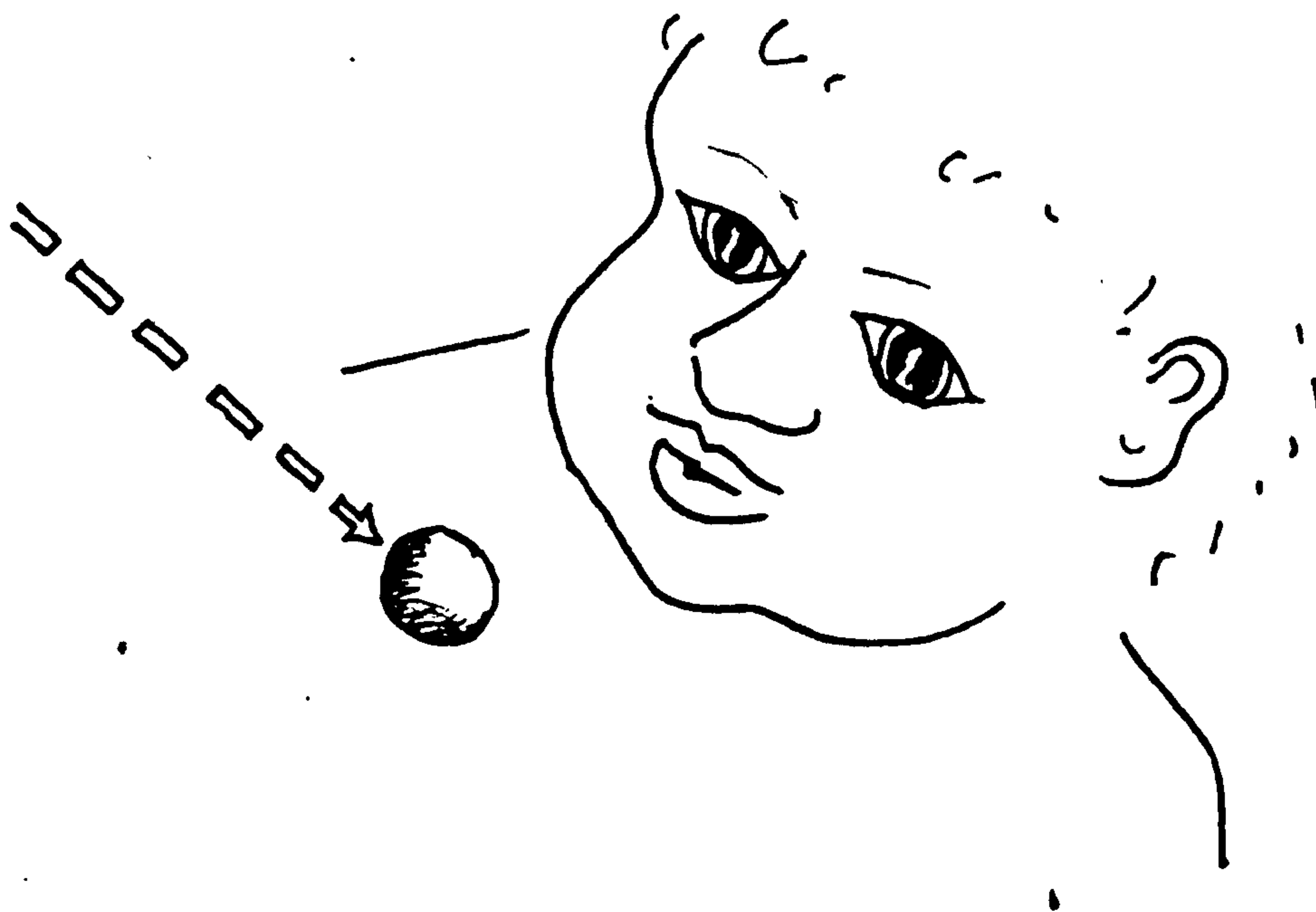

Criterion

The child passes this item if his eyes smoothly follow the object along its path of movement.

Explanation

The child who passes this item has learnt that he can employ the muscles of his eyes to maintain the object in his field of view. His application of an action has an effect on the image he receives.

Item 2. Notices the disappearance of a slowly moving object

Administration

As in item 1 but this time the object moves slowly along its path and disappears from the child's view behind a screen; or over the edge of the table. This may be repeated several times.

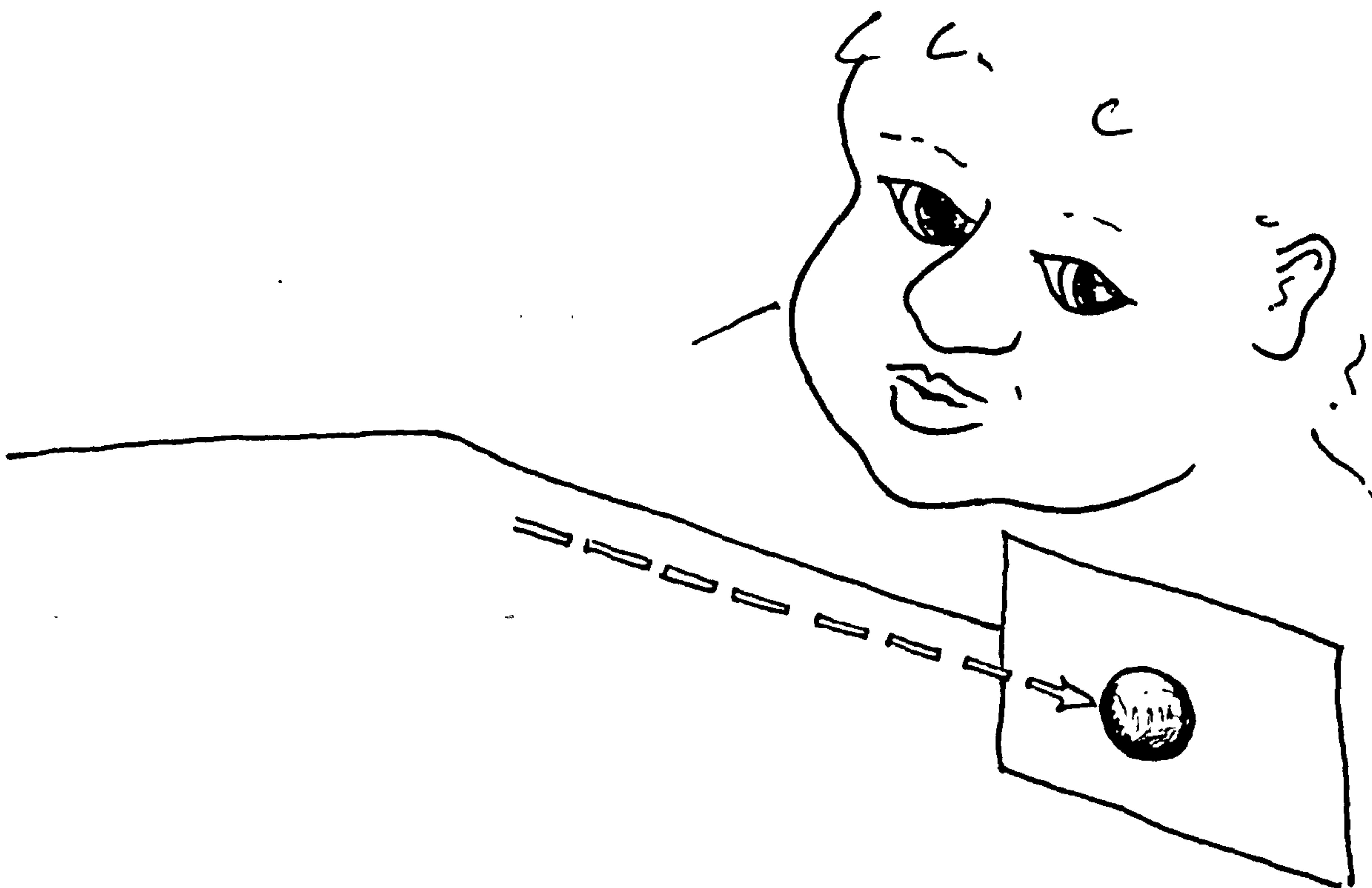

Criterion

The child 'notices' the disappearance of the object. This would be based on observing the child persisting in looking at the point of disappearance or returning his glance to the starting point after several presentations. Failure to reach criterion would be demonstrated by his losing interest in the object after it disappears. In this latter instance, with retarded children, it is advisable to establish, by re-presenting the object, that the child is still interested in the object.

Explanation

Here the child's knowledge is essentially the same as in item 1 but he has now acquired confidence in his ability to maintain the object in view by using his eye muscles, such that when the object disappears, he persists in trying to make it reappear by operating the muscles, i.e. by "looking." You will note that in this explanation we assume that the child knows that the object is "there." What he doesn't know is how to make the object reappear.

Item 3. Finding an object which is partially covered

Administration

An object which the child is interested in is partially covered by a cloth, or similar. It is important that the object should be such that its appearance partially covered is not identical to its appearance uncovered, e.g. a partially covered rectangle remains a rectangle.

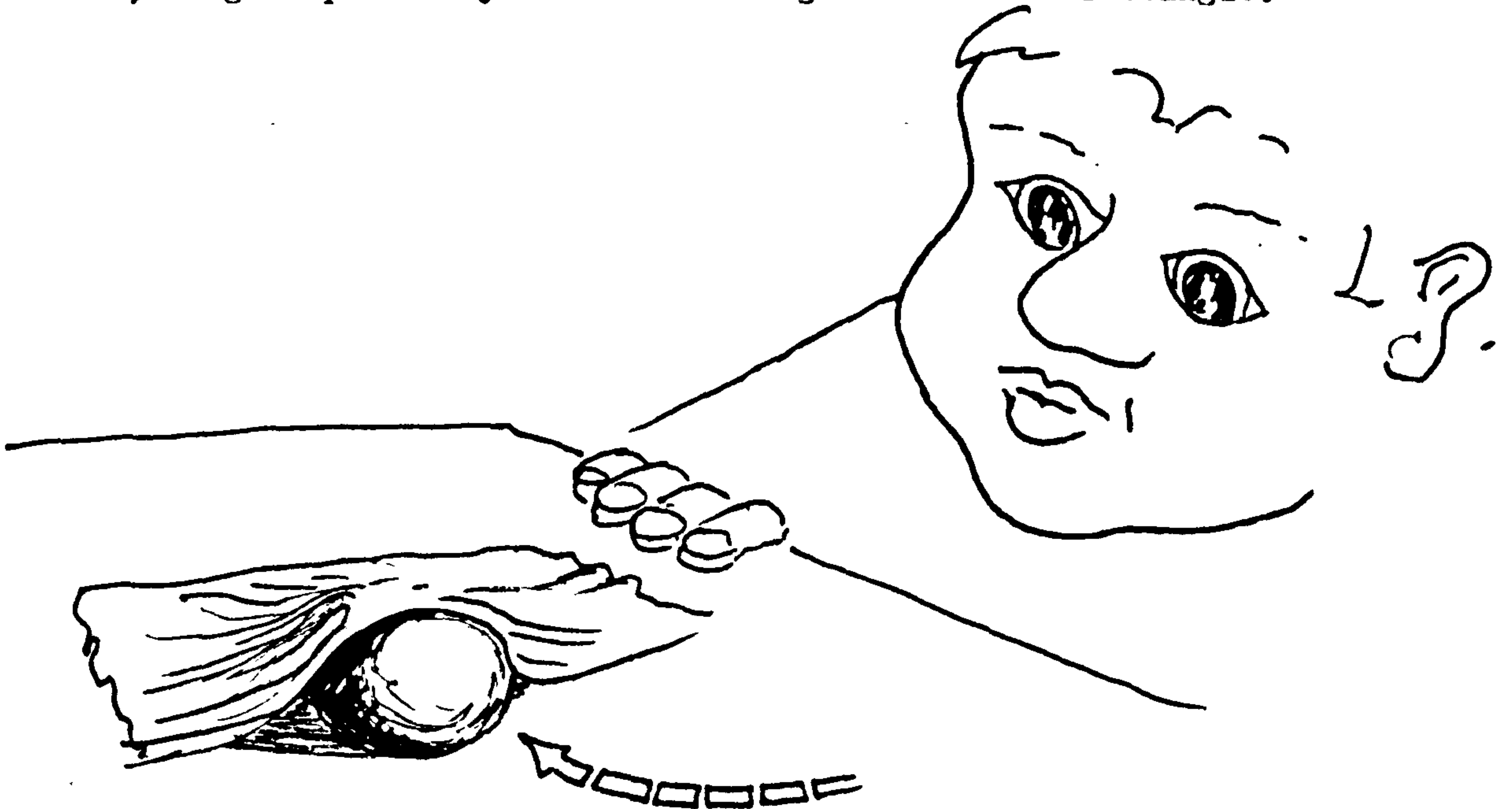

Criterion

The item is passed if the child obtains the object from under the cover. He fails if he loses interest or even reacts to the loss but does not retrieve the object.

Explanation

Prior to this situation, the assumption seems to be made that the child has learnt to attend to objects as a whole constellation of attributes to which he may apply his actions. This item demonstrates the ability to apply the same set of actions to an image manifesting some, but not all, the attributes of the original object.

Item 4. Finding an object which is completely covered

Administration

An object in which the child is interested is placed under a towel (or behind a screen) in front of the child.



Criterion

The item is passed if the child retrieves the object.

Explanation

Here it seems that the child is attending to the object's location as an attribute of the object but it also seems possible that the attended attribute is the actions that the adult has applied to the object. Some support for the latter explanation is derived from the observation that it is often possible to "teach" this stage to a child by physically holding his hand and getting him to "hide" the object, thus demonstrating to him how the object got to its location.

It seems here that how the object is hidden is crucial. If the object is placed on the table in front of the child and then covered, then the object's location is the salient feature. If the object is slid under, or behind the screen, then the object's "behaviour" (the actions it is subjected to) becomes the salient feature. The important point, though, is that moving up the object permanence scale, what we are finding is that the child is becoming less dependent on complete perceptual information and is increasingly able to work with fewer clues which themselves get increasingly divorced from the purely perceptual domain.

Item 5. Finding an object completely covered in two places

Administration

Two screens are employed here and placed side by side, a short distance apart, in front of the child. The object is first hidden under (or behind) one screen and the child allowed to retrieve it. The object is now hidden a second time behind the same screen and again the child is allowed to retrieve it. For the third hiding, the object is placed behind the second screen and the child allowed to retrieve it.

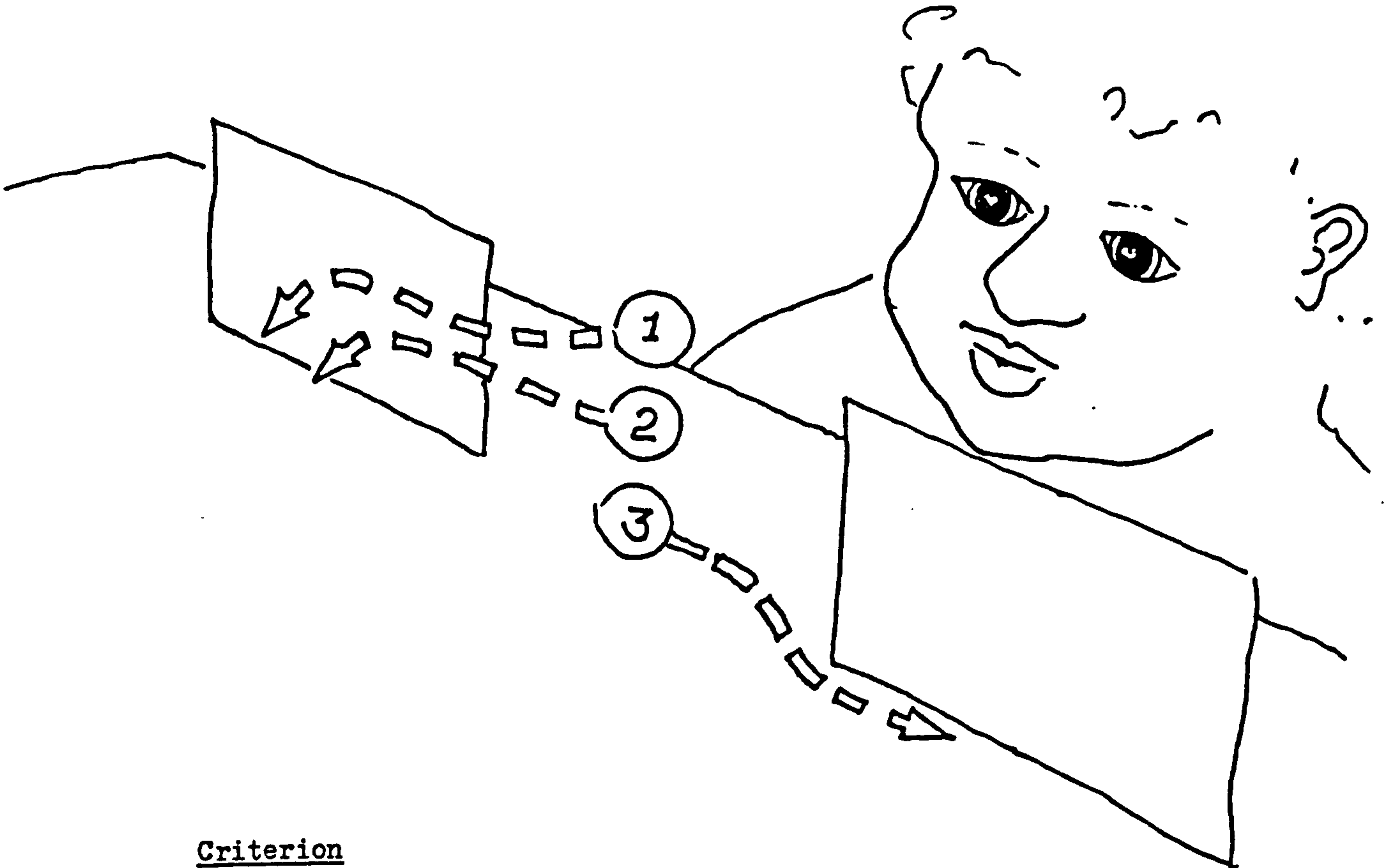

Criterion

The item is passed if the child is able to retrieve the object after the third hiding.

Explanation

Here, what we are doing is setting up an expectation that the object is to be found, behind the first screen, so it is possible for the child to succeed in retrieving the object after the second hiding by assuming that the object is defined by its location. If the child depends on this hypothesis to such an extent that he does not attend to the object's behaviour, then he fails on the third hiding.

So, whereas item 4 is mainly concerned with finding if the child can cope with one attribute, item 5 deals more specifically with asking "can the child use the actions applied to the object as information about the object?".

Item 6. Finding an object completely covered in two places alternately

Administration

Here, as in item 5, two screens are employed but the object is hidden alternately behind each screen.

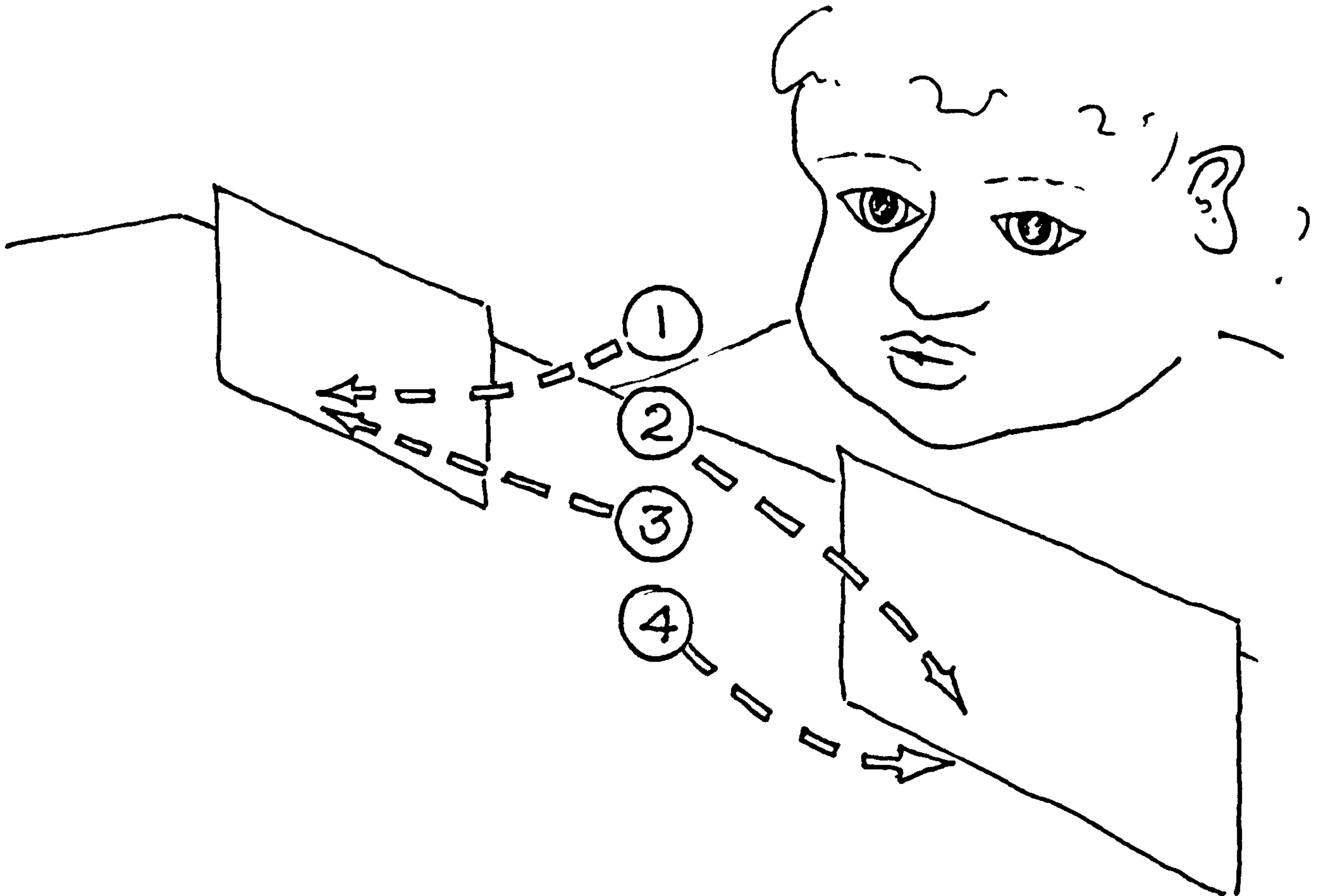

Criterion

Searches correctly under each of the screens.

Explanation

Success at this task depends on the child having the ability to represent the object in terms of the actions applied. Frankly, I am unclear about why item 6 should be more difficult than item 5. It is possible that the child at item 5 can use the applied actions as information but tries to fall back on the other ones such as location, but where there is a contradiction between expectation and information, he can use the information. In this item then, what we might be seeing is the child coming to rely on applied actions as a source of expectations.

Item 7. Finding an object completely covered in three places

Administration

Three screens are here employed and placed side by side. For each hiding, the object is placed randomly behind one of the three screens.

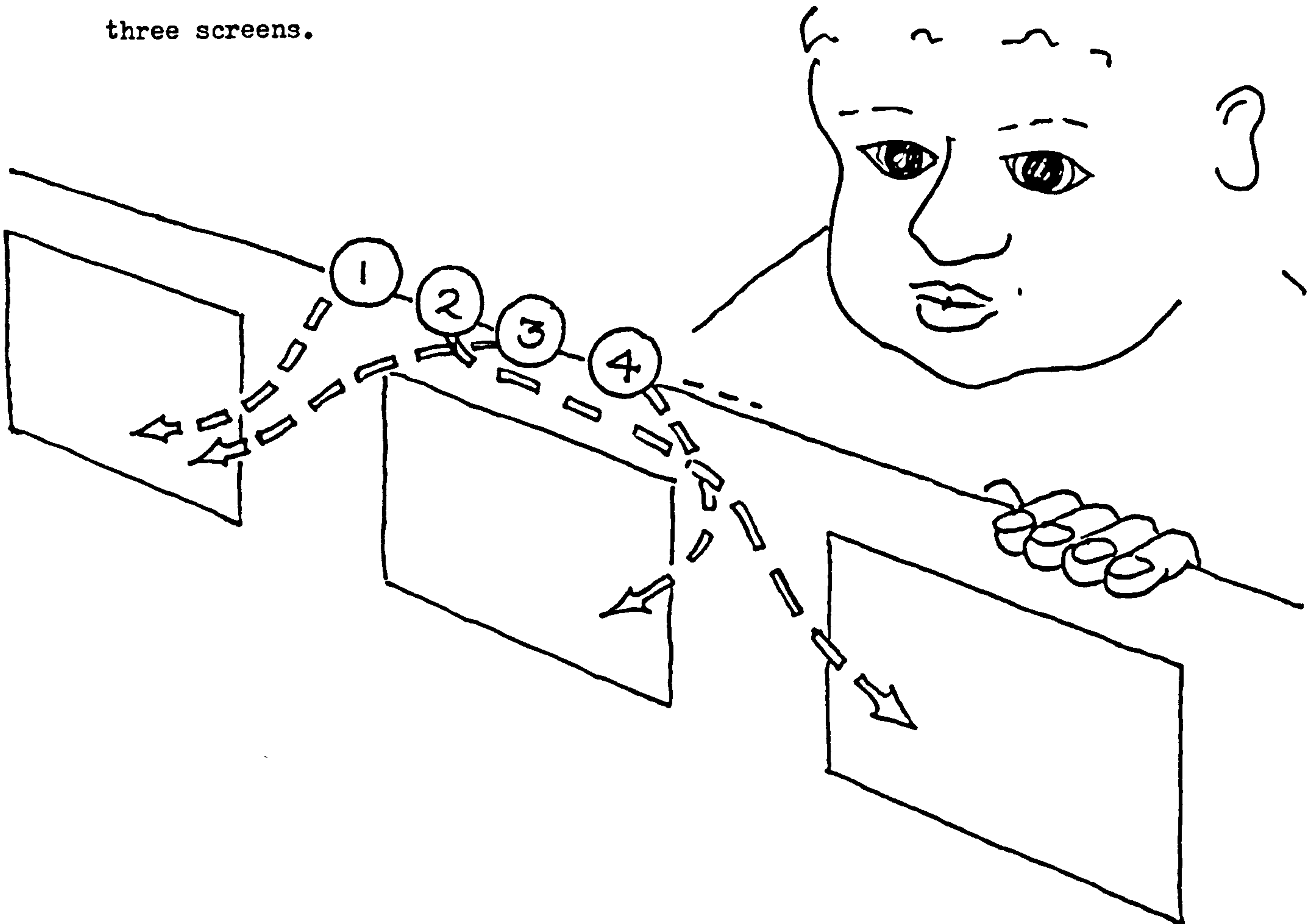

Criterion

Searches directly under the correct screen each time.

Explanation

This item appears to test, under conditions of greater complexity, the child's ability to define the object's location in terms of where the adult has placed it.

Item 8. Finding an object after successive visible displacements

Administration

Three screens are placed as in item 7, side by side. This time, the object, in the view of the child, is passed behind the first screen, on behind the second screen, then on to the third screen. The object is left behind the third screen and the adult then demonstrates that his hand is empty. It is advisable to pause behind each screen.

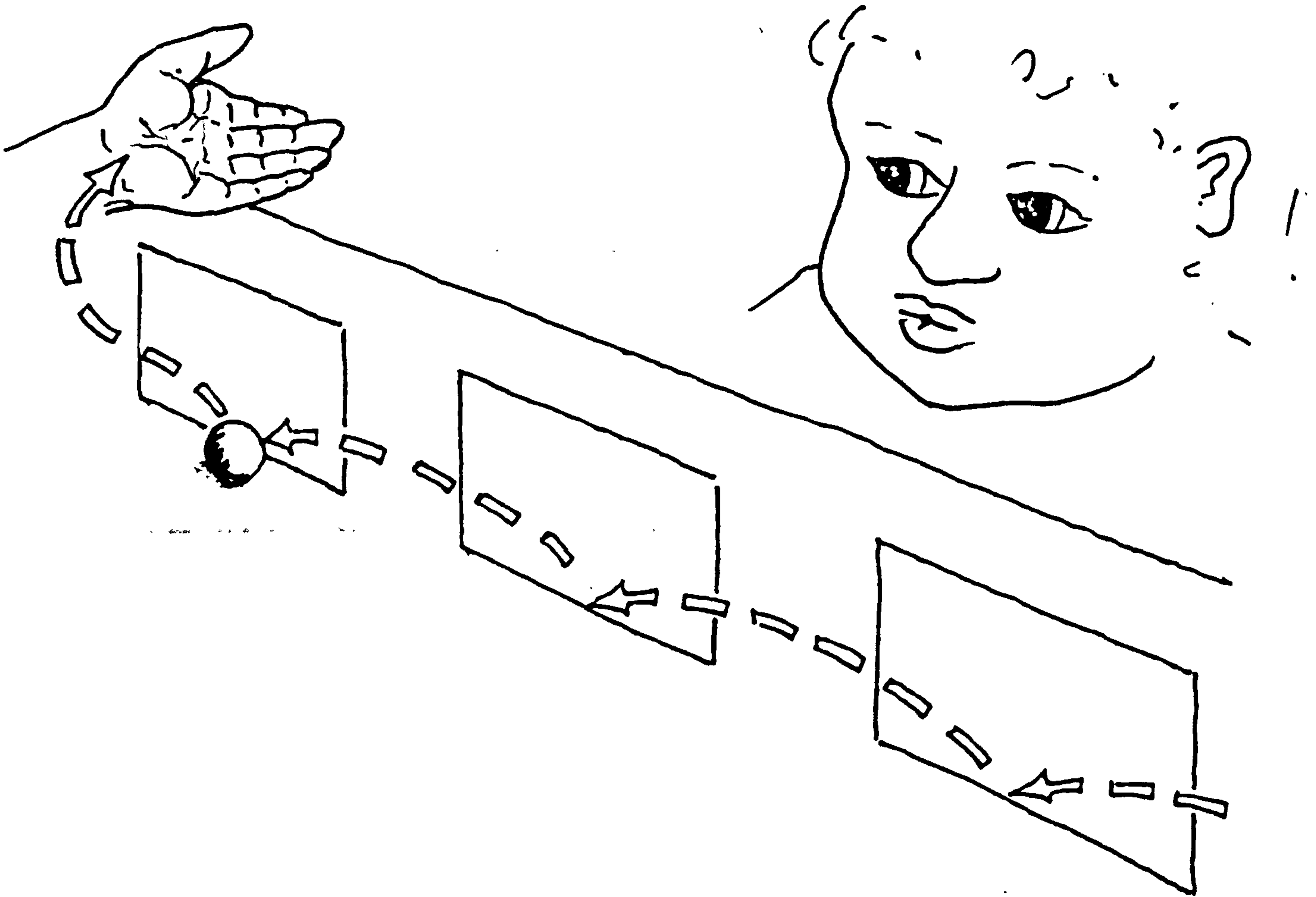

Criterion

Uzgiris & Hunt provide no criterion for this item since their investigation produced too few instances to be included in their analysis. They suggest that there may be two steps between item 8 and 9. However, we will provisionally accept that the child passes this item if either they search the screens in the order of hiding or go directly to the last screen.

Explanation

It seems here that we have a situation where each time the object disappears the child can formulate a hypothesis about its location but on each reappearance, disconfirming information is given so the child has to formulate a new hypothesis. This item then seems to test a flexibility of hypothesis formation-reformation. However, with increasing competence in this situation, the child can presumably deal with a new rule, viz. the object is behind the screen from behind which it does not reappear.

Item 9. Finding an object under three superimposed screens

Administration

The object is placed on the table in front of the infant and covered with a cloth. This is again covered with another larger cloth which is again covered with a third cloth.

Note If the object used is small, such as a sweet, it is as well to use nesting covers. (Sweets tend to get lost in a pile of towels.)

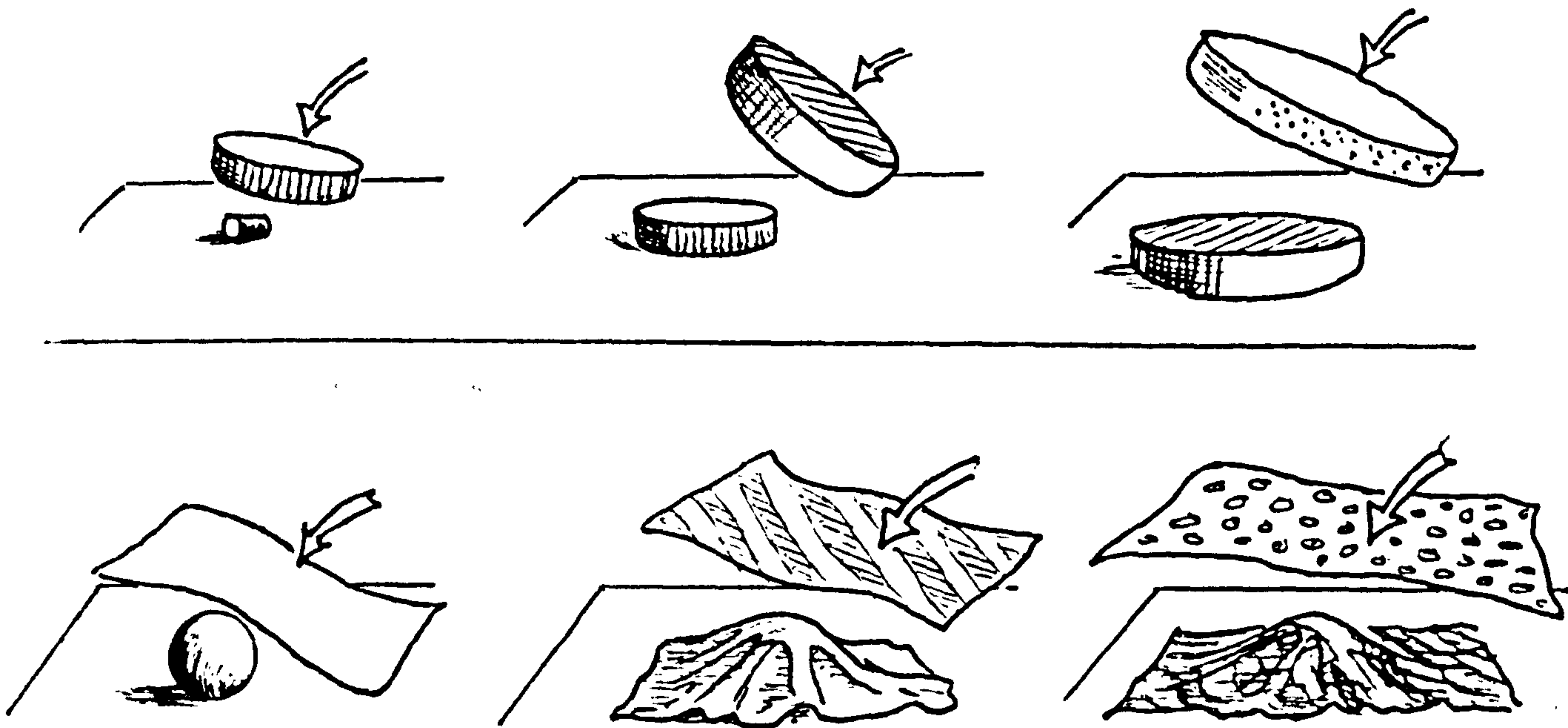

Criterion

Removes all screens and takes object.

Explanation

Here we seem to be testing the child's confidence in his ability to find the object, by testing his persistence in continuing to search.

Alternatively, what may be going on is that in order to obtain the object hidden here, the child must be able to cope with a representation of the adult's actions applied, not to the object itself but to the covers and these actions not having an effect on the object's location. i.e. He must be able to distinguish actions which change the object's location from those actions which do not change the object's location.

Item 10. Finding an object following one invisible displacement

Administration

Here the object is concealed under a cover, such as a cup, or in the adult's hand. The concealed object is then placed behind a screen (or under a cover). The original concealing cover is brought back into the sight of the child. This is termed an invisible displacement.

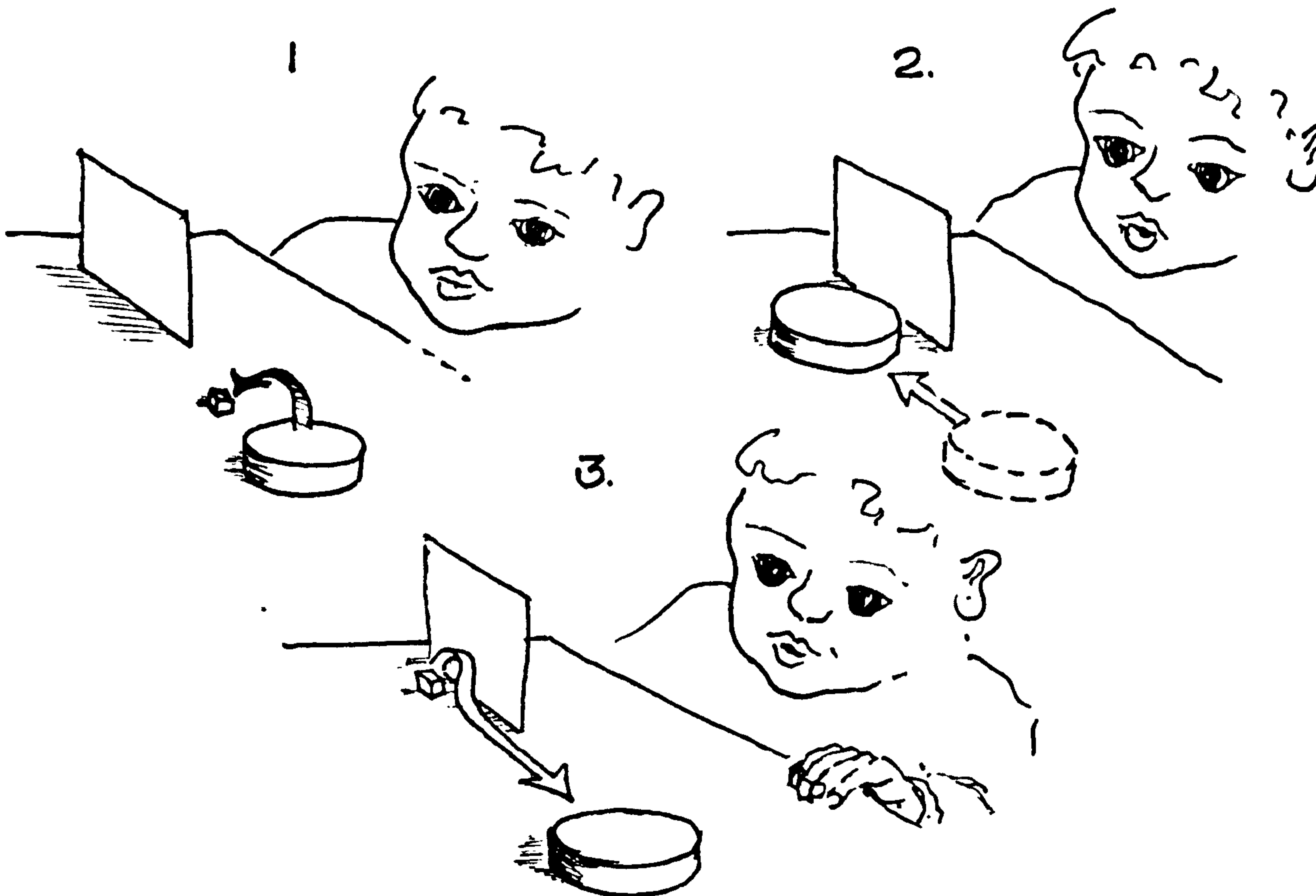

Criterion

The child passes this item if he looks under the cover, then looks behind the screen. If he looks directly behind the screen, it is likely that some cue has been given or that he may be operating a hypothesis that in these 'games' the object is always behind a screen.

Explanation

Success in this item requires some considerable representational sophistication. The child can represent what has happened to the object purely in terms of the actions applied to it and in the absence of any perceptual information about the object itself. He can cope with transformations 'in his head.' This level of representational competence is necessary, though not sufficient for symbol use.

Item 11. Finding object following one invisible displacement with two screens

Administration

Here, two screens of a different colour are employed and the object is concealed, as in item 10, under a cover. The concealed object is first hidden behind one of the screens and the cover brought back in front of the child, (i.e. a hidden displacement is operated behind the first screen) who is then allowed to look for the object. This hiding is repeated a second time behind the same screen. A third hiding is then done behind the second screen.

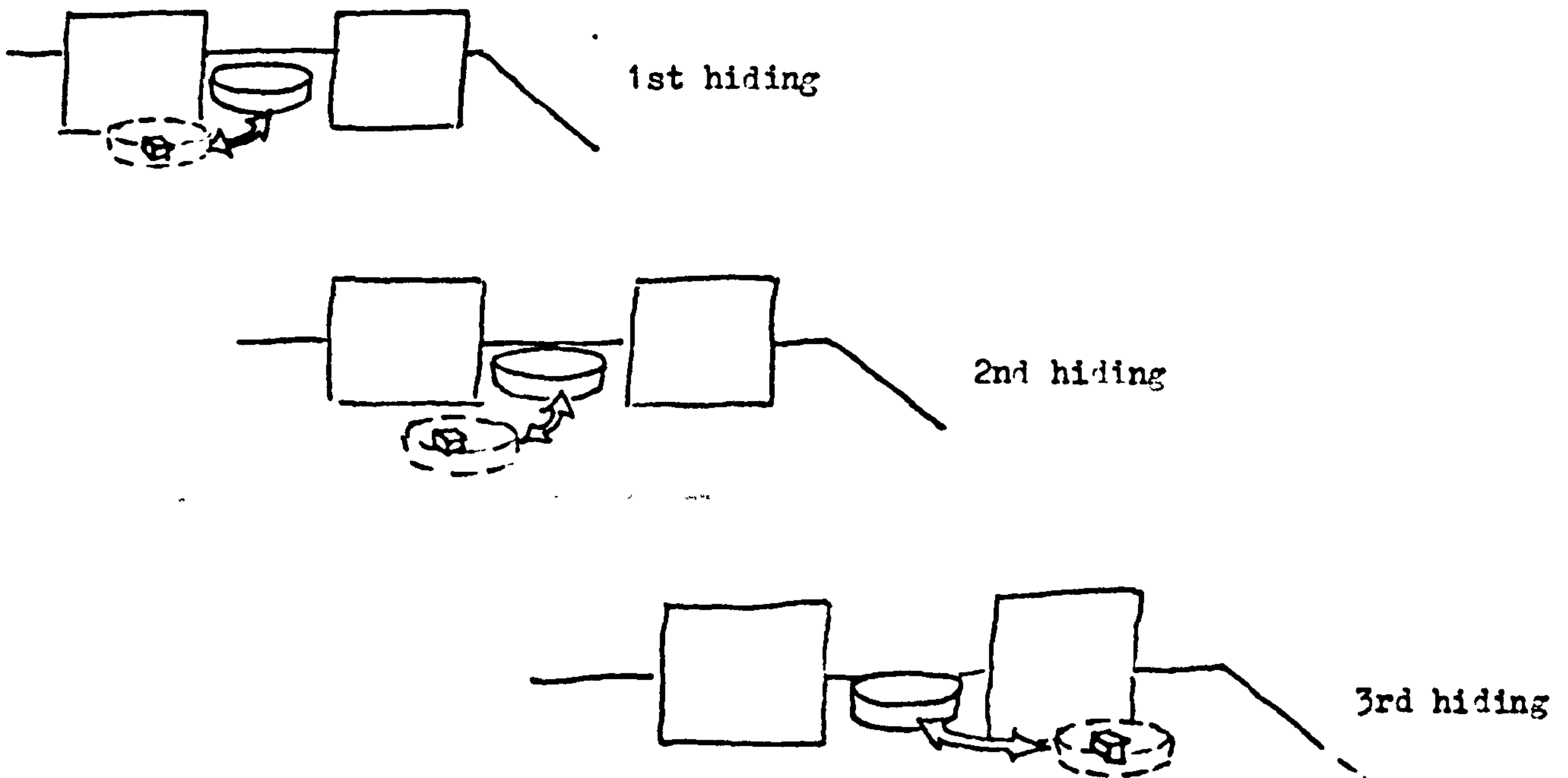

Criterion

The child passes this item if he goes directly to the correct screen.

Explanation

Here, the strength of the child's hypothesis that the object is where the adult's actions have transferred it to, is tested. In a sense, by the second hiding, the child is tempted to use an easier hypothesis - the object is to be found behind that particular screen. If the child has become competent in being able to mentally represent an absent object through a transformation, then he will not be tempted by the hypothesis of place.

Item 12. Finding an object following one invisible displacement with two screens alternated

Administration

As in item 11, but the hidden displacement is operated alternately behind the two screens.

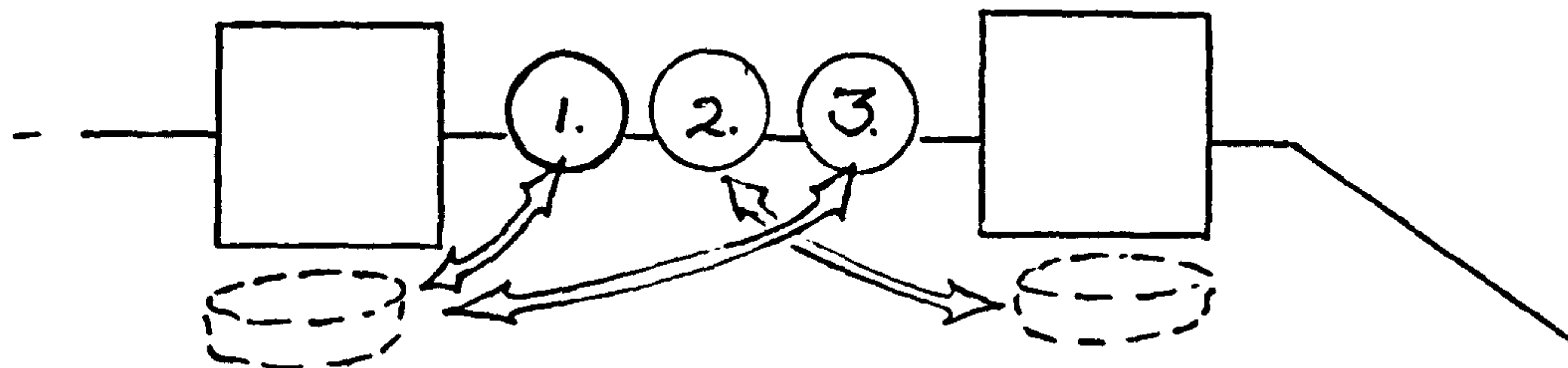

Criterion

The child passes if he searches directly behind the correct screen.

Explanation

As in items 5 and 6, I am uncertain why item 12 should be more difficult than item 11. A possible explanation is that in item 11 the task on the first two hidings seems easy and only on the third hiding is the difficult, discriminating item administered. Here, the complexity of the task is apparent on the second hiding and only a child really competent in the handling of mental representations of transformations will attempt item 12.

Item 12 may also discriminate between children who have competence at item 11 but who vary in their degree of risk-taking.

Item 13. Finding an object following one invisible displacement with three screens

Administration

Three screens are placed in front of the child and the invisible displacement operated behind any one screen. The child is then allowed to find the object. This is repeated randomly behind each screen about 5 times.

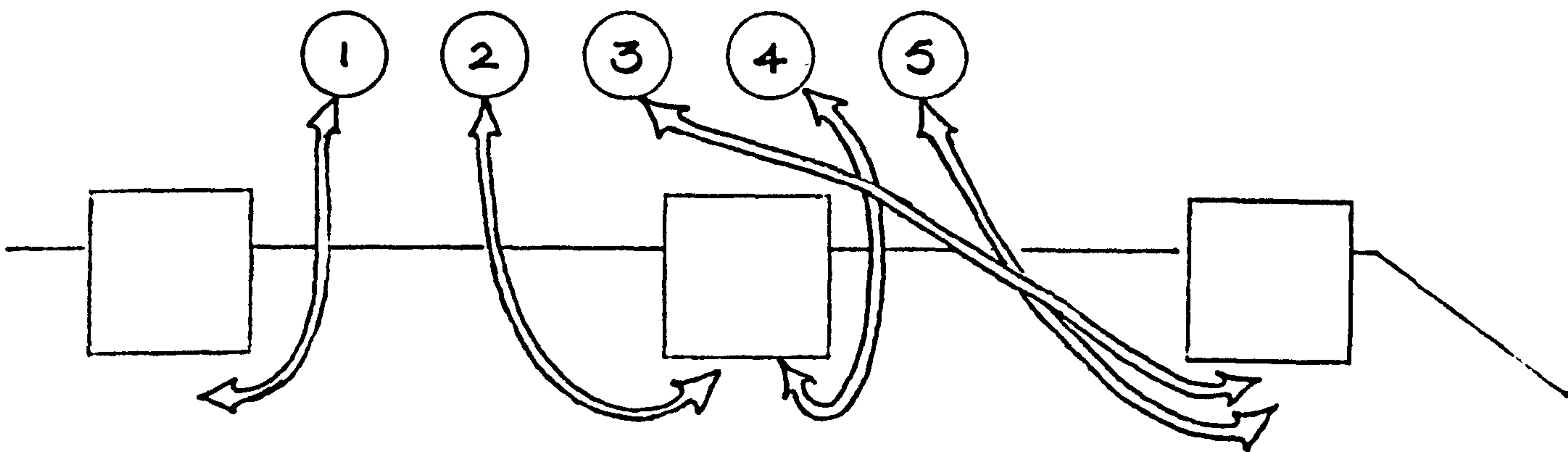

Criterion

The child searches behind the correct screen each time.

Explanation

This seems a further test of the child's competence with invisible displacements in a situation of greater complexity.

Item 14. Finding an object following a series of invisible displacements

Administration

A row of three screens is arranged in front of the child and the object concealed under a cover or in the hand. The concealed object is now in turn passed behind each of the three screens. It is important to ascertain that the child sees the cover passing between each screen. The object is left behind the last screen and the child is allowed to search. If the object is concealed in the hand, it is permissible to demonstrate that the hand is empty.

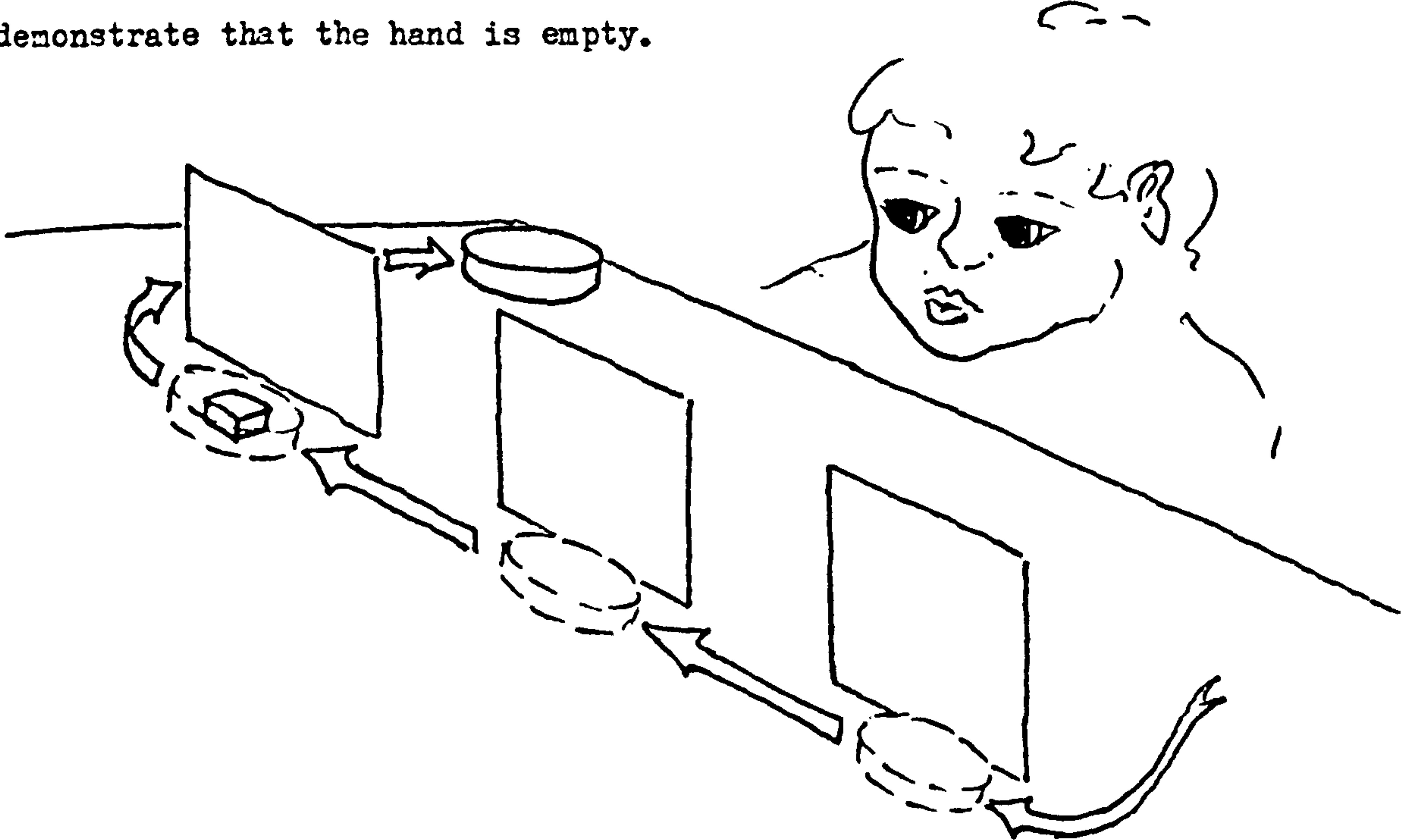

Criterion

The child passes this item if he searches behind the last screen.

Explanation

Here the child's representational sophistication is considerable. He can represent the passage of the concealed object behind the three screens and then operate the scale; that the object is behind the screen from which it did not reappear, to his representation of the object's passage.

Item 15. Finding an object following a series of invisible displacements by searching in reverse of the order of hiding.

Administration

As in item 14, but this time the object is concealed behind the first screen and the hand or cover then continues, empty, in a path behind the second two screens.

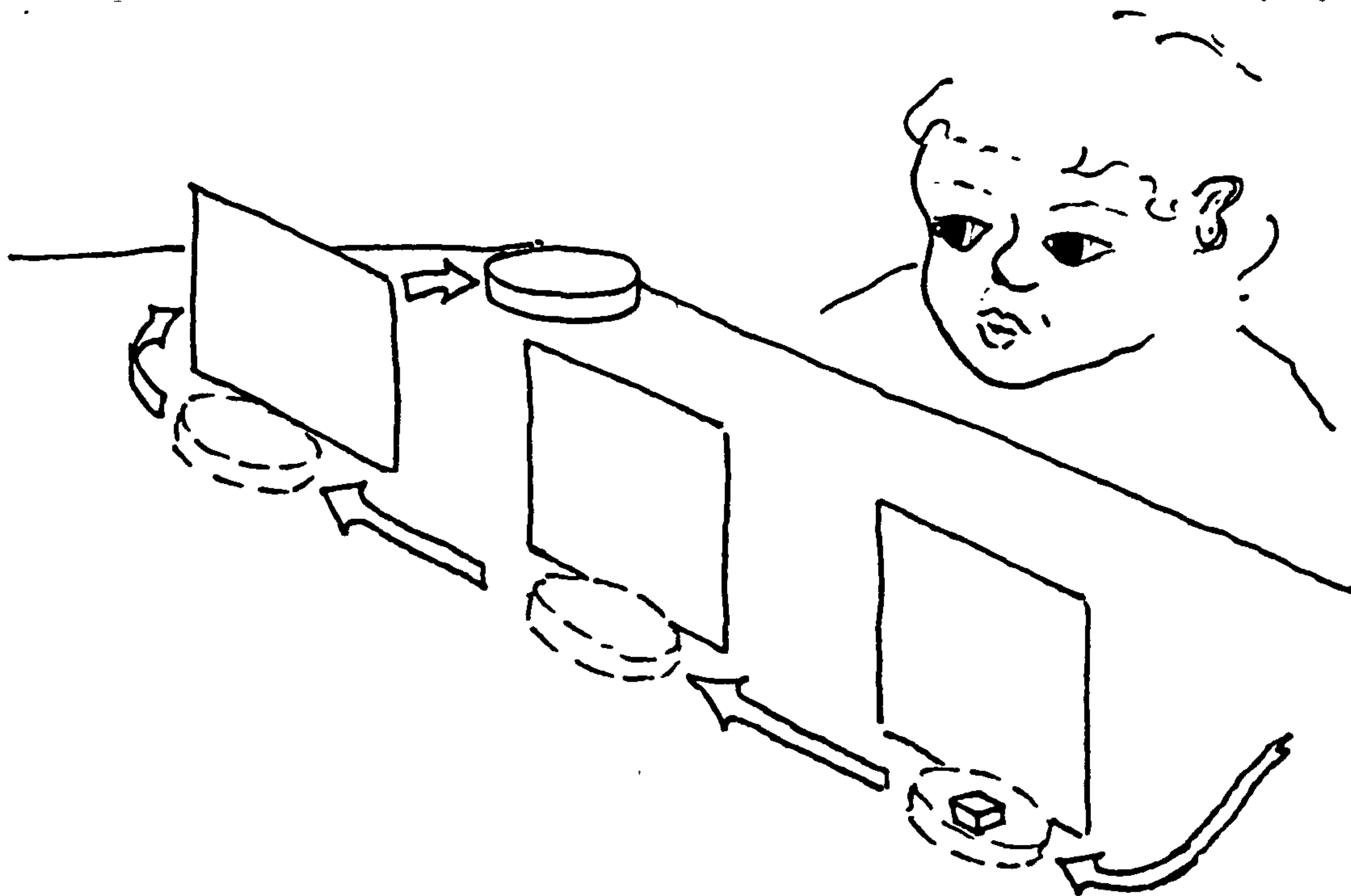

Criterion

Searches systematically from the last screen, back to the first.

Explanation

This item requires the same ability to apply the non-reappearance rule to his representation of the object's successive transformations, as item 14. But, further requires that having failed behind the first screen, he systematically reapplies the rule to the prior screen until the object is found.

By now, he is completely free of perceptual information about the object and can manage a "mental" construction of what has happened to the object; he can further devise actions to test the hypothesis in a systematic way.

SCALE II

The Development of Means for Obtaining Desired Environmental Events.

1. Appearance of Hand Watching Behaviour

Administration - Observation. The behaviour is more likely to be observed in the absence of visually attentive objects.

Criterion - hand watching is observed.

Explanation - The hand watching child has discovered that there is a relationship between what he does to the world and the effect it produces. He sends instructions to the muscles of his hand and observes his little pink digits wagging in front of him. There is an analogy here with tracking where again a specific action produces a certain perceptual effect.

The difference between hand watching and tracking is that tracking has to conform to a criterion of success - a goal - which is to maintain the object in view. In hand watching we have play; inasmuch as there is no criterion of success, the activity is done purely for the effect it produces. Hand watching seems to presuppose the ability to hold a gaze although profoundly retarded children without tracking abilities seem to engage in hand watching.

(2) Achievement of Visually Directed Grasping

Administration - An object of interest to the child is held directly in front of him, within his reach.

Criterion The child passes this item if he reaches out and grasps the object, this may not happen unless both hand and object are in view.

Explanation Here the child has discovered the possibility of applying the competence gained from hand watching to objects with which he was previously restricted to a passive perceptual relationship.

His hands have ceased to be an end in themselves and have now come to be a means to an end.

As in the development of the object concept, what we are beginning to see here is the child's relationship with the world changing from a passive reliance on perceptual information to an increasingly active relationship where the child increasingly makes sense of the world by structuring it in terms of the effects of his own action.

(3) Repetition of Actions Producing an Interesting Spectacle

Administration - Any object which produces a spectacle in which the child is interested when a simple action, such as hitting, is applied to it. Ideally, the spectacle should be both visual and auditory. Bells, rattles, roll upright musical toys etc. are suitable. Some experimentation may be necessary before finding a spectacle in which the subject is interested. With infants, the object is placed at a distance, then the child can touch it but not grasp it. With a more mobile, severely retarded child, this is rather difficult and it is probably better to allow the child to play with the object, occasionally interrupting the play to demonstrate the spectacle.

Criterion - Applies the action systematically and repeatedly to produce the effect.

Explanation - Here the child is now truly using his actions as a means to an end. His attention now focusses less on the action itself and more on the effects of the action.

(4) Letting Go of an Object in order to Reach for Another

Administration - The child is given two objects to hold, one in each hand. A third attractive object is then quickly presented and the child observed.

Criterion - The item is passed is the child puts down one of the objects in his hand prior to reaching out for a third.

Explanation - It seems that here we have the first intimation of foresight. Before operating the sequence: reach and grasp: it is possible that the child attends to the component units of the sequence and realises that in order to grasp, the hand must be empty, so he operates an action (putting down an object) in order for the necessary pre-conditions to be met.

This explanation implies that the child has the ability to represent his course of actions before he operates, i.e. he has a plan which he reviews in toto before operating.

(5) Use of Locomotion as a Means

Administration The child is seated on the floor and his interest is engaged in a pair of objects that "go together," e.g. a cup and saucer, and the child is allowed to play with them. One of the objects is then placed a short distance from the child such that in order to obtain it, he must crawl to retrieve the object. With retarded children, this item may be difficult to administer if the child's quality of play is poor. Placing an attractive item out of the child's reach does not really test this item. Some insight might be obtained by selecting two types of edibles that the child likes but has a greater preference for one. The preferred object is placed out of the child's reach in his sight and he is given the second, less preferred item.

Criterion The child is observed to obtain the out-of-reach item. Where preferred edibles are used, the child would possibly have to reject the offered edible and obtain the preferred but out-of-reach edible. This latter criterion is speculative. It is presupposed that the child is mobile.

Explanation Here, the situation is set up where the child is executing a plan, with variations. By moving one of the objects out of reach, the execution of the plan is blocked and the child has to bring in a complete competence system - locomotion, and apply it to the situation in order for the original plan to be executed.

Structurally, this item is very similar to item 4, the difference being in the relationship of the adjustment made to the plan itself. In item 4, the inserted element - "put down the object" is a variation of the components of the plan. In this item, the inserted element's relationship to the plan is superficially arbitrary and its usefulness is only apparent when the operation - move to the object - is completed. This implies that not only is the original plan's representation used but the insert - "move" is itself represented as a plan and the outcome checked before it is operated.

(6) Use of Relationship of Support

Administration - The child is seated at a table upon which is spread a towel within reach of the child. On the towel, well out of the child's reach, is placed a desired object. The child is observed. In the case of more mobile sub-normal children, they may stand up in order to reach the object, in which case, it is necessary to restrain them. Since this action could be interpreted as a communication, that the object is forbidden, it will be necessary to demonstrate to the child how to pull the towel to get the object, in order to 'give permission.'

Criterion The item is passed if the child obtains the object by pulling the towel, with or without demonstration.

Explanation Here, the child in his assessment of the problem and his formulation of his plan will incorporate the towel as a means to an end. So, in items 4 and 5, the inclusion of new elements is applied to ready existing plans. Here, the secondary element is incorporated into the child's plan in its first formation. So, the child is beginning to design plans of longer sequences.

(7) Understanding of the Relationship of the Support

Administration - The situation is identical to item 6 except the object is held a few inches above the towel. It is necessary that item 6 is first administered.

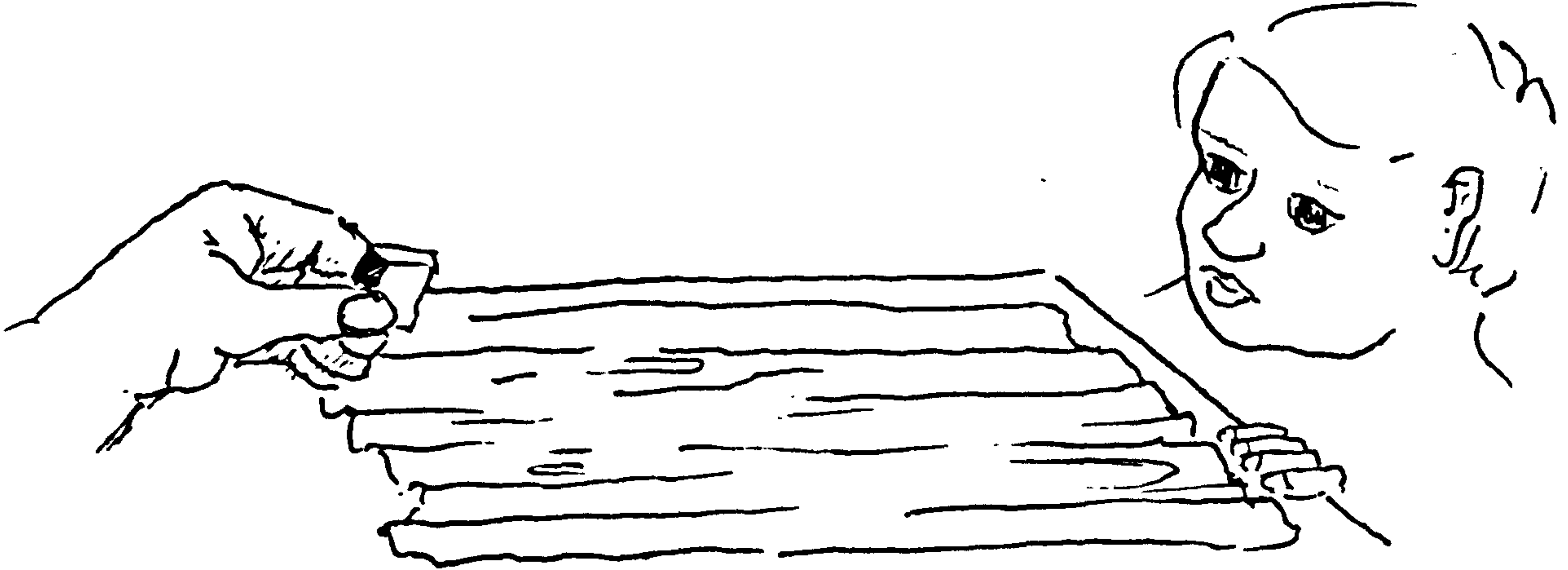

Criterion The child makes no attempt to employ the towel as a means of obtaining the object.

Explanation Here, the possibility of using the towel as a means of obtaining the object is presented but, in order to ignore the 'temptation,' the child must fully understand that the object must rest on the towel for the operation to work.

Here, we are differentiating between the vague realisation, (possible in item 6,) that by pulling towels, objects located at the far end will come closer; and a much more exacting set of criteria which demand that the object must rest on the towel for the operation to succeed.

(8) Use of String Horizontally

Administration - A desired object to which a length of string is attached, is placed either on the table or on the floor - out of the child's reach but, with the string within the child's reach. The child is required to pull the string in order to obtain the object. It is permissible to demonstrate that the string may be pulled in order to obtain the object. Some obsessional children have a great liking for string and the object needs to be very attractive.

Criterion The child, with or without demonstration, obtains the object by pulling the string.

Explanation I am unclear why this item should be more difficult than item 7. Structurally, both items are very similar and intuitively it would seem that the child will have had more experience of pulling string, in the form of wheeled pulling toys than of pulling objects placed on towels. Two speculations seem possible.

Either (i)

My intuitive assumption about the child having experienced string pulling is incorrect, and that the pulling of string toys occurs during and after this item. Retarded children are usually more mobile than normal infants operating at the same cognitive level, and this eventuality will affect the relative difficulty of this item in the two groups.

Or (ii)

Assuming the child has had experience of string-pulled toys, it may be the case that the child has a construction of 'string-pullable in the presence of wheels.' The absence of wheels might violate the criteria of this construction. This may be doubtful if we suppose that the child learns negative criteria only when the criteria are diagnostic - e.g. things on string without wheels cannot be pulled.

(9) Use of String Vertically

Administration The child is seated in a chair and the desired object attached to a piece of string is suspended vertically so that the object is out of reach but within sight of the child, and is obtainable by means of the string.

With more mobile children, it may be necessary to resort to expedients such as standing the child on a table to administer the item. If necessary, it is permissible to demonstrate the solution.

Criterion The child without or with demonstration obtains the object by acting on the string.

Explanation This item, though structurally similar to the other two, demands a full understanding of the relationship between the string and the object since it is not likely that he has had experience of vertical string pulling. The task may also demand greater motor competence if a hand over hand technique is necessary.

(10) Use of Stick as a Means

Administration - A desired object is placed on a table well out of the child's reach. On the table, within the child's reach is placed a stick long enough to obtain the object. If the child does not attempt to obtain the object, it is permissible to demonstrate how to use the stick. With more mobile children who are liable to lunge across the table, it seems permissible to place the object on a high shelf and require them to knock it down with the stick.

Criterion Without, or with demonstration, the child obtains the object.

Explanation In the items involving the towel or string, the situation is presented in which the potential means and relationship is presented to the child. Here, he must be able to construct a representation of the potential before he can use it. Even if the solution is demonstrated, the child needs to be able to represent the demonstration. If he cannot represent the demonstration, then he will not be able to understand the 'answer.'

(11) Foresight in the Problem of the Necklace and Container

Administration - For this item, a long thin and unstable container and a necklace is required. A clear plastic tube sealed at one end is very appropriate. Without putting the necklace in the container in sight of the child, the child is required to put the necklace in the container. The main point of this item is that in order to put the necklace in the container, it is necessary to steady the container with one hand whilst putting the necklace in with the other. This item asks, "Does the child foresee that he will have problems with the container's instability before he attempts to put the necklace in?" The child may of course invent other appropriate means of coping with the container's instability - such as bunching the necklace into a ball or dangling it.

Criterion

At the first attempt, the child adopts a way of pulling the necklace in which shows that he has foreseen problems arising out of the container's instability. Uzgiris & Hunt comment that the child who has a few unsuccessful attempts at the problem before solving it may be demonstrating an intermediate stage between 10 and 11.

Explanation

This item demonstrates the operation of foresight which involves considerable representational sophistication. The child must represent the problem and make 'dry runs,' or simulations, of the solutions that occur to him in order to select the best solution before actually operating it. Since we are only interested in the demonstration of foresight, a wide variety of situations are possible as substitutes for this item. Item 10, if done without demonstration and it can be assumed that the problem is unfamiliar, would be an appropriate demonstration.

(12) Foresight in the Problem of the Solid Ring

Administration - Several identical wooden or plastic items (discs, cubes, spheres etc.) are used each with a hole such that they can be threaded onto an unmounted rod. The hole on one of these items is visibly blocked. The child is required to thread the items onto the rod. It is permissible to demonstrate the task with one or two of the items but it is not permitted to draw attention to the plugged item. Should the child select each item for the rod leaving the plugged item last and not attempting to put it on, then the problem should be re-presented and the items re-arranged, to increase the probability of the plugged item being selected.

Criterion

The child makes no attempt to thread the solid ring onto the rod.

Explanation

As item 11, this item demonstrates the operation of foresight. The content of this item seems to have greater subtlety in that the focus of the foresight is focused on a detail of the materials employed rather than on an overall property. Though, again, the relative difficulty of item 12 over 11, may reflect the child's greater experience of unstable containers than plugged holes.

SCALES IIIa and IIIb - Imitation

Introduction

The child's assessed performance on this scale is particularly sensitive to the ambience created by the adult. Uzgiris & Hunt suggest that once the infant begins to direct his behaviour towards the adult (by smiling, giving him toys, etc.) then it is appropriate to administer the scale. With the severely retarded and institutionalised child, such signs of readiness may not be so clear.

The child can be encouraged to be interested in the adult by bouncing on the knee, tickling etc. It is important to develop a playful situation. As Bruner (1977) states in a discussion of the origins of communication in the mother infant dyad.

"When things become too 'serious' and intention-bound, communication regresses to the level of demand and counter-demand. The simulative, conventionalised and rule-sensitive spirit of play seems to be a sine qua non for language learning."

In this scale, we are looking at some of the elements of pre-language learning.

SCALE IIIa - Vocal Imitation

Item 1. Use of Vocalisation other than crying

Administration - Observation of child's vocalisations.

Criterion The child is observed to produce vocalisations other than those indicating distress, e.g. (crying).

Explanation The situation is structurally analagous to hand watching, whereby the child operates an action and observes the results. The child repeats this sequence in order to reproduce the effect.

- - - - -

Item 2. Response to Familiar Vocalisation

Administration - Talk to the child in a normal adult manner observing the child's response; then utter one of his own sounds a few times. Pause and observe the child. Repeat the child's sounds. It is appropriate to shift to a different sound in the child's vocabulary.

Criterion The child is observed to respond in some positive manner to sounds similar to his own.

Explanation This item demonstrates that the child can differentiate between his own sounds and the more complex sounds of adult speech. This implies that he has some representation of the effects of his own action and moreover can recognize the similarity between adult imitations and his own sounds.

Item 3.

Response to Familiar Babbling Sounds

Administration - When the child is not vocalising spontaneously, gain his attention and feed back to him babbling sounds (as opposed to cooing sounds of item 2) which he has been previously observed to utter. Repeat the babble a few times then pause and observe his responses. Repeat the babble. If the child has a variety of babbles which he frequently uses, change to a different babble after three or four presentations of the first one. Repeat this procedure for 2 or 3 different sound patterns.

Criterion

The child demonstrates an active interest in the adult's performance. This may range from:

- i) The child smiling, producing mouth movements and continuing to look at the adult during pauses.
- ii) Produces similar sounds to the adult and changes his sounds to match those of the examiner.

Explanation

The criterion for this item covers quite a range of competence. Structurally, the item is similar to item 2 in that the child recognizes and may repeat adult vocalisations similar to his own. The fact that he has moved from simple cooing to the patterns of sounds which constitute babbling indicates that representationally, he can cope with sequential patterns of sounds.

Item 4. Imitation of Familiar Words

Administration - Words, or wordlike sounds produced by the infant as fed back to him by the adult and his response during pauses are observed.

Uzgiris & Hunt suggest that where the child uses meaningful words, objects or pictures corresponding to the words used by the child are used. Where objects are used, it is important to repeat the child's words back to him when he is not too engrossed in the object play.

The 'words' in this item may be idiosyncratic and their 'meaning' known only to a person who has close regular contact with the child.

Criterion

The child is observed to vocalize in response to the adult's productions.

Explanation

Although objects may be used in this item, the child's meaningful use of sounds is not the focus of this item. This item seems to investigate the child's ability to represent and produce 'chunks' of regularly occurring patterns with a definite beginning and end. So, in items 2, 3 and 4, we have the following sequence:

Item 2 : Competence in producing single sound elements.

Item 3 : Competence in stringing these elements into open-ended patterns.

Item 4 : The ability to represent and produce regularly occurring sequences into new, higher-level units.

This new level of representation implies that adult sounds are no longer heard by the child as an ongoing jumble of sounds but that he can perceive adult sounds as sequences of words. It would seem plausible that to do this, he has attended to the intonation contours of adult utterances. Although it is not at issue in this item, it seems that the child may at least 'suspect' a relationship between words and 'things.' Moreover, the patterns of sounds produced are beginning to conform to the patterns of the child's native language.

Item 5.

Imitation of Unfamiliar Sound Patterns

Administration - Sound patterns unfamiliar to the child are used here. When he is not spontaneously vocalising, gain his attention and produce one of the unfamiliar sounds. Do this several times, pause and observe his response. Repeat this procedure a few times. If the outcome is not clear, repeat the procedure using another new sound.

In this item, the novelty of the sound is important and some observation for some time before the administration of the item may be necessary.

Criterion

Vocalises in response to the adult's utterances. The vocalisation does not have to correspond to those made by the adult.

Explanation

Since Uzgiris & Hunt do not demand that the child's vocalisation necessarily approximates to the adult's production, this item seems to test that the child at least 'entertains' the possibility that he can attempt an unfamiliar sound, i.e. he has the notion that sounds not within his representational repertoire are reproduceable. It is plausible to argue from this that the child has some sort of awareness of himself as an agent, at least in the domain of social sounds.

Where, within this item, the child does succeed in reproducing new sounds, then it seems necessary that he has some good overview of how to organize his vocal chords, mouth, tongue etc. to produce a new sound, before he actually operates his attempt to form the sound. Were he to do this by trial and error, then it would take him a very much longer time to produce replicas of new sounds than it in fact does take.

Item 6. Imitation of New Words.

Administration - Simple words, not within the child's repertoire, are repeated to the child whilst the child is playing but not too intently, with the appropriate object, adjectives may be used. Alternatively, the situation may be focused on the Adult-Child interaction where verbs such as bounce, jump, kiss etc. may be used. Following a few presentations of the word, pause and observe the child's behaviour. Repeat a few times with the same word then change to another word. Follow the above procedure until about 6 or 7 different words have been used.

Criterion

The child is observed to either directly imitate all the new words or else to produce approximations which improve with practice for all the words.

Explanation

This item demonstrates that the child has good overall organization of his vocal apparatus which allows him to a certain extent, to predict what sound patterns will emerge from the operation of specific sequences of vocal actions.

It also seems possible that the child has some working knowledge of the rules of patterns of sound combinations which characterize the language of his environment.

Item 1. Systematic Imitation of Familiar Simple Schemes

Administration - The infant is observed at play in order to determine which simple actions (schemes) he employs.

When the infant is not playing, reproduce one of these actions then pause and observe the child's behaviour. Repeat the procedure a few times until the child's response becomes clear, then repeat again using another simple action that the child employs. With retarded children who use stereotypies, it is appropriate to use their stereotypy as a scheme.

Criterion

The child passes this item if he responds with a consistent action to the adult's performance.

The child's actions may or may not be an imitation of the actions produced by the adult.

Explanation

In this item, the child demonstrates that he can see that his own actions and those of the adult have some relationship. When the child imitates his own actions preferred by the adult, he demonstrates that he can see the identity between his own actions and the adult's, and is further interested in testing out this relationship.

When the child responds to the adult's performance with a different but consistent action, it is less clear what goes on. It is plausible that the child recognizes the adult's actions as familiar and responds to it with the first action pattern that comes 'to mind.' This implies that, although the child recognizes the action as familiar, he cannot reconstruct it in a new context. (He would normally apply it to an appropriate object.)

If this is the case, it is then unclear why the child should not, on each attempt, change his actions to those more clearly resembling the adult's performance. He may be focusing on the sequence "You do that; I do this; you do that; etc." rather than on the similarity.

Item 2. Imitation of Complex Actions Composed of Familiar Schemes

Administration - The principle underlying this item is that an consistent action that the child uses spontaneously is selected and the adult uses it in a more complex context. So, for example: the child may bang a brick on the table. The adult places several bricks on the table, selects two of them and bangs them together several times. The adult then observes the child's response. The adult may help the child in placing the bricks in his hand. Other examples might be: the child can shake a rattle; the adult places a brick inside a cup and shakes the cup - then presents the child with a cup. The child bangs one hand on the table; the adult claps his hands together.

Criterion

The child is observed at least to attempt to imitate the adult's actions.

Explanation

The child here demonstrates that he can at least perceive the possibility of a relationship between his action and the more complicated context that the adult has placed his actions within.

As in item 1, the child's success in imitating is not at issue, it is his recognition that it may be possible for him to do what the adult does that is being tested.

Item 3. Imitation of Unfamiliar Gesture Visible to the Child

Administration - A gesture that is likely to be unfamiliar to the infant is selected and performed in front of him when he is attentive. His responses are observed. This procedure is repeated for 2 or 3 different unfamiliar gestures.

Criterion - The child passes this item if he succeeds, either immediately or through successive approximations.

Explanation - In order to be able to imitate an unfamiliar gesture, the child must go through the following steps:

- (1) Look at the adult's actions and break them up into their component muscular parts plus develop some representation of how the bits fit together.
- (2) Identify the component muscular actions in his own body.
- (3) Assemble these into a coherent plan of action, then,
 - either(4a) Where the child is observed to imitate by successive approximations, he operates his plan and then compares, noting differences, his actions and the adult's. Then he must incorporate the information back into step (3) and repeat (4a) until he is 'happy' with the match.
 - or (4b) Where the child is observed to produce a successful imitation, he must be able to represent how his plan would look in operation and compare it to the adult's without actually operating his plan.

Several points emerge from this explanation.

- (1) Whereas in item 2, the child is involved in integrating familiar complex actions into even larger units, here he needs to be able to unpack his own actions into smaller components and reassemble them to form new complex actions.
- (2) The initiation of unfamiliar actions is a complex skill that requires that the child can, as it were, stand outside himself and look at his own actions as objects of his perception.

The explanation I've attempted here also implies that the child can, to a certain extent, represent the adult's actions as a system apart from himself. Between item 2 and item 3 in this scale, much seems to have happened which the scale does not reflect.

Item 4.

Imitation of Unfamiliar Gestures Invisible to the Infant

Administration - The adult engages the child's interest and performs an unfamiliar action which the infant cannot see himself doing unless he had a mirror, e.g. pulling his ear lobes, putting his finger on his tongue, opening and closing his mouth etc.

The infant's response is observed after several demonstrations. The procedure is repeated for 3 or 4 gestures.

Criterion

The child passes this item if he makes some consistent attempt to imitate the adult's actions. Whether he succeeds or not is not at issue.

Explanation

Ignoring for the moment the fact that the criterion only demands that the child makes a consistent attempt to imitate rather than succeed, the main point is that a concealed imitation requires the child to be able to represent in some form how his actions would appear, from outside his body. In practice, this would involve that the child can perceive the equivalence between, say, the adult's tongue and his own.

Where the child makes an attempt (though unsuccessful) to imitate the invisible gesture, what is demonstrated is that although he cannot actually solve the problem, he assumes that the problem is 'solvable.'

APPENDIX.2.

DAISY

INTRODUCTION

Daisy is a withdrawn and mute lady in her late 50's, who has been a hospital patient for the past 40 years following an initial diagnosis of schizophrenia. It is not known whether the original schizophrenic process is still operating. In 1952 a leucotomy was performed but it is unclear what bearing this has on her present condition.

Prior to the onset of her illness, Daisy appears to have led an active and rich life, enjoying sport, dancing and music. She was well educated and was employed as a clerical worker in the civil service.

Daisy is capable of some speech and will on rare occasions, utter a word or phrase. This appears to be more likely to happen when she is angry.

Over the past 12 months Daisy appears to have progressed as a result of sensitive and attentive management by nursing staff, e.g. she now feeds herself though still needs to be prompted to go and get her her food.

INTERVENTION

AIM

The aim of my involvement with Dorothy was to explore and develop means of enabling her to enjoy social interaction such that she might begin to talk again.

ASSUMPTION

The assumption was made that Daisy found social interaction aversive because she had no control over any ensuing interaction. For example, if Daisy smiled and looked at someone, they would reciprocate and initiate further behaviours which she may or may not have been able to cope with. This uncertainty led to increased anxiety so her solution was to avoid giving any signals which initiated or maintained social interactions.

PROGRAMME

This assumption suggested that one way of helping Daisy was to give her an experience of very low level interactions which she could terminate if she so wished. Accordingly, I saw her 3-4 sessions a week, usually of half hour duration and set about initiating a variety of games, which I felt that she could cope with, and responding to any signals of aversion that she gave.

A game which very explicitly followed this principle and which was used a great deal in the earlier sessions involved rhythmically tapping Daisy's chair and observing her eyes. If she looked away from me I would discontinue the tapping, if she looked in my general direction I would recommence the tapping. As the proportion of time spent looking in my general direction increased (this included occasional direct eye contact), I moved closer to Daisy by tapping her hand. Again I employed her gaze direction as an indication of when I should discontinue and recommence my behaviour. Through such games Daisy gained increasing tolerance of physical contact and in a period of 8 weeks responded to games such as being shouldered almost off the chair with hoots of laughter and would occasionally and very tentatively push back.

Much of my interaction with Daisy involved my sitting with her and talking. Topics of conversation were always problematic since her responses were minimal. In earlier sessions I drew sketches of her and made comments about her long eye lashes etc. Comments which she responded to tended to be about the here and now, e.g. the behaviour of other patients, programs on the T.V. I had introduced topics from her past such as references to her former ability to play the piano, but Daisy usually responded to these efforts by turning away.

It was very noticeable that if I was talking to another person and one of them commented about what Daisy was doing, she would immediately desist and withdraw.