

PIT Tag Antennae Arrays as Fishery Monitoring Tools in Tropical Environments

ANDREW B. BARBOUR^{1,*}, AARON J. ADAMS², DONALD C. BEHRINGER¹,
TANNER YESS³, and R. KIRBY WOLFE⁴

¹Program of Fisheries and Aquatic Sciences, School of Forest Resources and Conservation, The University of Florida, PO Box 110600, Gainesville, Florida 32611 USA. *snook@ufl.edu.

²Center for Fisheries Enhancement, Fisheries Habitat Ecology Program, Mote Marine Laboratory, Charlotte Harbor Field Station, P.O. Box 2197, Pineland, FL 33945 USA. ³Department of Biological Sciences, Northern Kentucky University, Highland Heights, Kentucky 41099 USA. ⁴Habitat Program, Marine Fisheries Section, Coastal Resources Division, Georgia Department of Natural Resources, One Conservation Way, Suite 300, Brunswick, Georgia 31520-8687 USA.

ABSTRACT

Long-term monitoring of marine and estuarine fishes is labor intensive and subject to varying environmental conditions and spatio-temporal constraints. To better understand fish populations and increase predictive capabilities, scientists and managers need reliable long-term monitoring systems that collect data on populations through all environmental conditions and reduce the labor required for data collection. To collect long-term data on fish survival and movements, we adapted autonomous passive integrated transponder (PIT) tag antennae for use in tropical environments. These antennae function through all environmental conditions, accurately recording the unique identification number of each PIT tagged individual passing over an antenna, and only require labor for construction, data download, maintenance, and the marking of fish. Antennae have long life spans and function continuously, and PIT tags have a lifespan measured in decades, making this system ideal for long-term studies. The utility of this recapture system was demonstrated during a nursery habitat study in Charlotte Harbor, Florida USA. From November 2008 to February 2010, we marked 1,446 juvenile common snook (*Centropomus undecimalis*) with PIT tags (and a total of 3,810 snook since 2004). Between August 2008 and August 2010, the 11 antennae we constructed throughout four mangrove creeks recorded 362,880 PIT tag detections of 1,594 individual fish. The antenna array recaptured 83.7% of fish marked after antenna construction was complete. The detailed recapture information allowed for highly precise calculation of apparent survival and examination of long-term habitat use. In addition to discussing the data we have collected, this paper details how to design and construct customized PIT tag antenna systems and covers the issues and limitations associated with adapting these systems to tropical marine and estuarine environments. These systems may be especially useful in the tropics for monitoring juveniles of other species that use near shore nursery habitats such as mangroves.

KEY WORDS: Telemetry, passive integrated transponders, snook, *Centropomus*

PIT Matrices Etiqueta de Antenas como Herramientas de Seguimiento de la Pesca en a Ambientes Tropicales

PALABRAS CLAVE: Etiqueta de Antenas, herramientas, robalo, *Centropomus*

PIT Tag Antennes comme des Outils de Surveillance des Pêches dans les Environnements Tropicaux

MOTS CLÉS: Antennes, surveillance des pêches, snook, *Centropomus*

INTRODUCTION

Long-term monitoring of marine and estuarine fishes is a fundamental source of information for assessing changes in populations, especially with respect to alterations of habitat and environmental conditions. However, most current monitoring methods are labor intensive, restricted by environmental conditions, and/or may return insufficient data to properly monitor the population of interest. Thus, new avenues of assessment must be developed, which collect data through all environmental conditions, reduce the labor required for data collection, return highly detailed data, and allow long-term monitoring.

Mark-recapture methods are popular tools for monitoring and assessing fish populations. A variety of mark-recapture methodologies exist, including chemical, external, and internal marks. Most marks require a marked

individual to be physically recaptured, while some allow 'virtual' recapture of individuals through telemetry. Depending on the selection of mark-recapture methodology, information on survival, population size, movement, and/or growth can be collected - all of which are important metrics for studying marine fishes (e.g. Beck et al. 2001). The following provides an introduction to a mark-recapture system ideally suited for long-term studies of survival, movement, and habitat use. Herein, we detail the design and construction of autonomous PIT tag antenna systems in a mangrove nursery study of the common snook, *Centropomus undecimalis*, in Charlotte Harbor, Florida (USA) and provide a preliminary examination of data collected with this mark-recapture system.

Mark-Recapture

The basis of mark-recapture studies is the mark. A variety of marks exist for fisheries studies, each presenting their own advantages and challenges. For example, chemical tags (*e.g.* oxytetracycline, alizarin) can be used to quickly mark a high number of fish, provide valuable age information, and can be used on early life-stages (*e.g.* Tsukamoto 1985). However, reading a chemical tag requires the killing of the marked fish, thereby making multiple recaptures of an individual impossible and making this a difficult mark to use on threatened populations. External tags (*e.g.* spaghetti, anchor, dart) can be implanted in a high number of fish due to their low cost, can give detailed movement data when incorporating angler recapture information, and can be used to collect growth, survival, and population size information (*e.g.* Jagielo 1995); however, only a low percentage of marked individuals are recaptured in most studies (*e.g.* Wheeler and Winters 1984, Jagielo 1995), and tag shedding is a common occurrence (Barrowman and Myers 1996). Furthermore, active sampling by researchers rather than passive angler tag reporting is labor intensive and reliant on appropriate environmental conditions (*e.g.* tides, wind, and weather). In comparison, internally implanted acoustic tags can be recaptured at a high rate during all environmental conditions by a well-designed receiver system with minimal effort (*e.g.* Heupel and Simpfendorfer 2002), but are expensive, reducing the number of marks. The battery life of the marks and receivers also limits acoustic studies by making long-term monitoring of individuals difficult.

Passive integrated transponder (PIT) tags have increased in popularity since their introduction in the 1980s (Gibbons and Andrews 2004). PIT tags are normally internally implanted, which nearly eliminates tag shedding in many species, and are currently available in a range of sizes from approximately 6 - 32 mm in length. PIT tags contain a uniquely coded 16-digit identification number, allowing identification of individuals. PIT tags are relatively inexpensive, costing approximately US\$2.50 per tag in this study. The low cost of PIT tags allows for a high number of individuals to be marked. PIT tags are ideal for long-term studies since they contain no battery and have indefinite life spans (Gibbons and Andrews 2004). To power a PIT tag, the reading unit generates a magnetic field that induces an electric charge on a copper coil within the PIT tag. The tag is then activated and transmits its unique identification number to the reading system through a small antenna. The maximum distance at which a reading unit can fully charge and read a PIT tag is termed 'read range.'

There are two types of PIT tags, which differ in how they receive and transmit data: half duplex (HDX) and full duplex (FDX). HDX tags alternate receiving and transmission periods, while FDX tags receive and transmit simultaneously. FDX readers cannot read HDX tags, and vice versa, but ISO readers are capable of reading both tag

types. FDX tags can be manufactured in smaller sizes than HDX tags as HDX tags rely on a capacitor to hold a charge, which currently limits their minimum size to 13 mm. However, larger PIT tags have a larger internal coil to intersect the reader's magnetic field, allowing them to be read at greater distances from the reading unit. In our research, we used HDX tags (23 mm length x 3.4 mm diameter, 0.6 g in air; Texas Instruments TIRFID S-2000) due to their lower cost, simplicity of use, and larger read range, as compared to FDX tags. We inserted tags into the abdominal cavity of our study subject, common snook (*Centropomus undecimalis*), through a 3 mm incision posterior and ventral to the pectoral fin. For this mark, we have found 100% tag retention with no mortality for juvenile snook > 120 mm standard length (SL) with no need for sutures to close the incision (Adams et al. 2006).

A strength of PIT tags is that they provide flexibility when selecting a recapture method, because marked individuals can be physically recaptured or 'virtually' recaptured through telemetry. Physical recapture of PIT tags requires a marked individual to be caught and scanned by a handheld reader (approximately US\$500). This presents many of the same challenges as physical recapture of fish marked with external tags (*e.g.* labor-intensive, typically low recapture rates, and dynamic environmental conditions) with the additional caveat that the participation of anglers in recapture is limited by access to expensive reading units. The potential in PIT tag technology as a monitoring and fisheries assessment tool lies in virtual recapture through telemetry.

PIT Tag Telemetry

PIT tag telemetry was developed for use in freshwater rivers and hydroelectric dams in the 1990s (Prentice *et al.* 1990). These constricted environments are ideal for the development of PIT tag telemetry, since the tag needs to be in close proximity to the reading unit to be detected, and the area a PIT tag antenna can span is limited by the length of its inductor coil. Recently, PIT tag telemetry has been applied to marine and estuarine environments with promising results (Adams et al. 2006, Meynecke et al. 2008). Multiple methods exist for PIT tag telemetry recapture, including prefabricated (*e.g.* Hewitt et al. 2010) and custom-built antennae (*e.g.* Adams et al. 2006). Custom designed antennae are ideal for marine and estuarine application, as they allow the flexibility required for unique environmental systems.

Custom designed PIT tag antennae require a fair degree of technical savvy to construct, but novice builders can successfully deploy these systems by buying prefabricated parts. A basic description of a PIT tag antennae includes a copper inductor coil (the antenna) connected to a tuning box, which is connected to a reader box containing a data-logging computer (Figure 1). Antennae plugged into an existing power source or powered by a battery bank recharged by solar panels will operate continuously. A

mounting station is required to house the reader box and power source above the water surface, and special care must be taken to protect these units when placed in harsh tropical climates. Technical savvy builders can construct tuners and readers by buying component parts for a lower cost than prefabricated units, but this is a complex and time consuming process. The following will detail the HDX PIT tag antennae we constructed using pre-fabricated tuners and readers (purchased from Oregon RFID) at a total per antenna cost of US\$4,000 - 5,000, while identifying the components that allow flexibility in design for custom application.

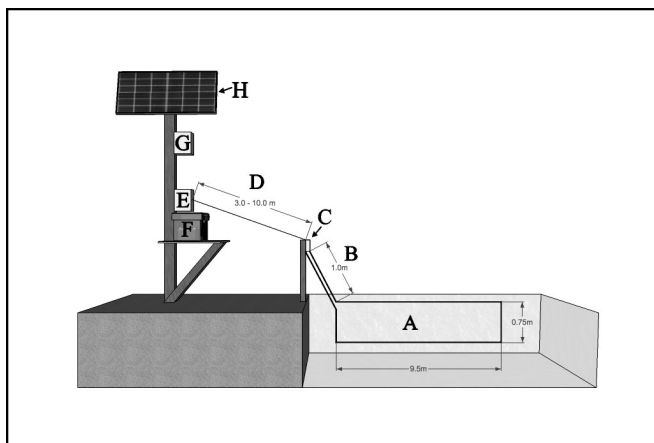

Figure 1. Schematic of tower antenna design (not to scale): A) Inductor coil; B) initial inductor coil cable; C) tuning box; D) twinaxial cable; E) reader box; F) battery box; G) junction box; H) solar panel.

Power Source

When constructing a PIT tag antenna, one of the first considerations is to determine how to power the system. PIT tag antennae can be powered by existing electrical power sources, but they are often remotely deployed, requiring a self-contained power source. We powered each antenna with two 6 V deep-cycle, flooded batteries (sold for golf cart or solar panel use) connected in series to form a 12 V power source. Using 6 V batteries is preferred over 12 V batteries, as they typically provide more amp-hours per dollar and typically have thicker lead plates, maximizing their deep-cycle function. Although we used a 12 V system, voltage levels from 12 - 24 V are commonly used. Increasing voltage would increase cost, as more batteries and a more expensive solar panel would be needed; however, increasing voltage would also increase maximum read range and antenna length, which may be desired in some applications.

Once a voltage and battery system has been selected, a solar panel is needed to recharge the system. We used a single 12 V, 130 W solar panel, which provided 7.4 A. It is important to note that smaller inductor coils will reduce resistance, thereby reducing amperage consumed and potentially allowing for a solar panel with less wattage.

Also, if a higher voltage system is to be used, a solar panel with higher voltage and wattage will be needed to provide sufficient amperage. The wattage of the solar panel system is also dependent upon the latitude in which the system is deployed. Our antennae were built at 26° N. Antennae built at higher latitudes will need higher wattages/amperages due to the decreased light levels. The orientation and horizontal tilt of the solar panel are also important. In the northern hemisphere they should face true (not magnetic) south and true north in the southern hemisphere, and the degree tilt calculated from: (study location latitude \times 0.9) + 29°. This optimizes the tilt angle for the winter months, when light levels are at their lowest.

After selecting a battery and solar panel system, a charge controller is used to connect the components. This device is wired directly to the solar panel, the battery bank, and the load (the reader box). We used 10-awg, 2-conductor boat/marine cable to wire all components to the charge controller. The charge controller prevents reverse-current flow (electricity flowing backwards from the battery to the solar panels at night), adjusts for varying temperatures, and protects the batteries from being overcharged. A lightning arrestor is also be wired to the solar panel input of the charge controller. The ground wire of the lightning arrestor is then attached to a single-strand copper wire (the thickest gauge available at local hardware stores), which is run from the metal frame of the solar panel mount to several rebar stakes buried in the ground; this system offers some protection in case of a nearby lightning strike. Additionally, instead of running the load (the reader box) directly through the charge controller, the load is run through a 30 A fuse connected to the charge controller to protect against potential power surges. The charge controller and fuse are housed within a PVC junction box (Figure 1G).

Inductor Coil

The other major consideration when designing a PIT tag antenna is the inductor coil (Figure 1A). The copper inductor coil is the only component that runs through the water column, and serves as the ‘antenna’ for detecting marks. Electric current is run through the inductor coil to generate the magnetic field necessary to charge and identify the PIT tags. Any metal in close proximity easily disrupts the magnetic field. The inductor coil is looped through the tuner box (Figure 1C), and capacitors are used to set the magnetic field at the proper frequency (134.2 kHz for HDX systems). The tuner box is connected to the reader (Figure 1E) via twinaxial cable (Figure 1D) (tuner and reader boxes can be purchased from Oregon RFID). The twinaxial cable can be up to 130 m in length. However, long twinaxial lengths have increased resistance, which reduces antenna voltage and read range. We used 3 - 10 m of 20 awg, 100-ohm twinaxial when constructing the system described here.

To construct the inductor loop we used 6-awg super vu-tron welding cable, consisting of 660 strands of 34-awg copper: this cable is well suited for harsh climatic conditions. This wire, the aforementioned power source, and twinaxial cable enabled us to use a maximum inductor cable length of 22.5 m. To span the maximum creek width, we constructed rectangular inductor loops. Rectangular antennae can be oriented in a swim-through (*e.g.* Adams et al. 2006) or flat-bed (*e.g.* Armstrong et al. 1996) orientation. We used flat-bed antennae due to concerns about entanglement by recreational users of our study creeks, and because our study subject swims low in the water column, reducing the need for a swim-through antenna.

There are two important design considerations when building a rectangular single-loop antenna with a given inductor wire:

- i) The width of the rectangle (the gap), and
- ii) The initial length of the wire loop exiting and entering the tuner box that is tied together (Figure 1B).

These two factors directly impact an antenna's read range (Figure 2). The combination of these factors not only determines the read range of the system, but also affects antenna length. For example, we obtained a maximum read range with a 120 cm gap and an initial cable length of 250 cm, but an antenna with these specifications would only be 7.55 m in length. Therefore, we sacrificed read range by using a 75 cm gap and 100 cm of initial cable length to build larger antennae measuring 9.5 m in length – the length necessary to span the majority of our study creeks.

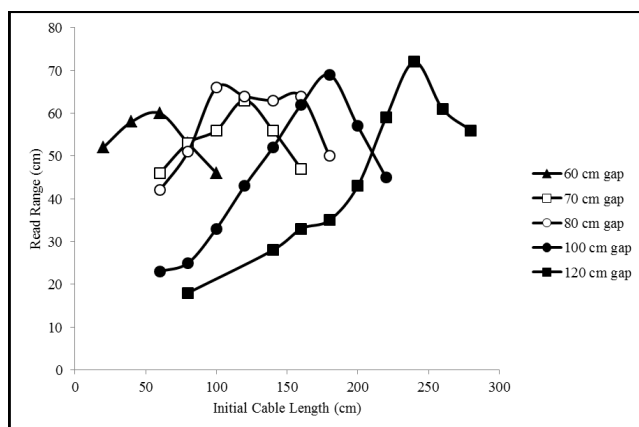

Figure 2. Read range from a single flatbed PIT tag antenna during dry-land testing, using multiple combinations of rectangular inductor coil dimensions. Of particular interest were the width of the rectangle (gap), and the initial length of cable exiting the tuner box that was held together (Figure 1B).

A variety of wire types can be used to create the inductor coil, providing flexibility in PIT tag antenna application. The resistance generated by electrons moving through the coil varies with each voltage and wire combination, which affects the maximum inductor coil length and read range. For example, an antenna measuring 7.3 m x 0.6 m was made using a single loop of 12 gauge THHN copper stranded wire and a 12 V power source (M. Brett Gallagher, Florida International University, Personal communication). Another antenna was made measuring 30 m x 1 m, using a single loop of 1/0 awg wire consisting of 1,580 strands of 32-awg copper and a 18 V power source (J. Vincent Tranquilli, Oregon Department of Fish and Wildlife, Personal communication). If constructing an antenna of different dimensions than described above, special care must be taken to select a wire and voltage combination that maximizes read range for the size and shape of antenna desired.

In addition to flexibility in inductor wire selection, multiple inductor coil designs exist. For example, it is possible to construct an antenna with multiple loops of inductor wire placed on top of each other. Multiple loops increase read range; however, the total antenna length is reduced. A challenge to constructing antennae with multiple loops is determining the proper 'air gap' between loops; this gap is often maintained by running wires through PVC pipes, as any metal near the inductor coil will disrupt the magnetic field, reducing read range. Also, while the system we describe involves a single tuner box, multiplex readers can be purchased, which allow multiple tuning boxes to be run from a single reader. Multiplex antennae allow multiple inductor coils to be constructed in close proximity, providing information on directionality of fish movement, while reducing cost compared to deploying multiple single antenna units. Multiplex units could also be arranged to cover a wider stretch of creek, river, or bay, by placing a tuning box and inductor coil on each side of the given habitat.

After designing an antenna system, one must determine how to lay the inductor coil. Although it is recommended to run the inductor coil through PVC pipe or attach it to a wood frame to hold the proper shape, we were unable to do this in the complex mangrove habitat of our study site. Instead, we used plastic zip-ties to attach the coil to mangrove prop roots and staked portions of the coil to the benthos using pieces of PVC pipe to prevent deformity from tidal water movement. Regardless, our antenna did not hold a perfect shape, which led to between and within antenna read range variability (Figure 3). Read range is also reduced by increasing salinity (Figure 3), as the magnetic field is attenuated by the saline environment. Further evidence for a decrease in read range due to salinity is found when comparing maximum read range obtained during on-land testing (Figure 2), versus maximum read range during saltwater testing (Figure 3). However, some of this difference may be due

to the way in which antennae were constructed in the field, as a perfect rectangle was not always maintained and not all inductor coils had identical gaps and initial cable lengths.

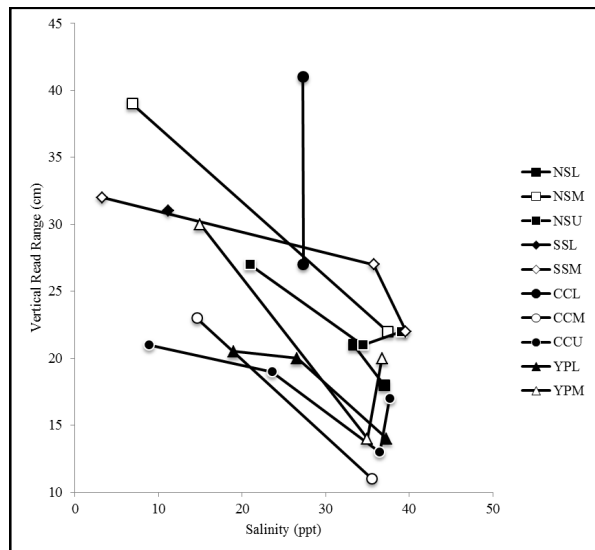

Figure 3. Read ranges of 10 antennae with rectangular flat-bed inductor coils deployed over 4 study creeks. Read range measurements were taken at multiple temporal points with varying salinities due to the study occurring in a tidally-flushed, coastal mangrove system.

Mounting the System

The tuning box must be mounted as close to the creek as possible to maximize the length the inductor coil can span. We mounted the tuner box two different ways:

- i) We layed the inductor coil as described above, tuned the antenna for maximum read range, closed and sealed the tuning box with liquid electrical tape, and zip-tied the it to mangrove branches,
- ii) Identical approach except we mounted the tuning box on a wood post (100 cm x 100 cm x 1.5 m) set 0.6 m set into the ground.

Regardless, it is important to mount the tuning box at a height that prevents it from being flooded at the highest tides, and leaves extra room for storm surges.

The second consideration is more difficult and involves mounting the solar panel, batteries, reader, and junction box (which houses various electrical components). The first antenna platform we designed, constructed in a salt marsh, was a table-like platform from wood 100 cm x 100 cms. This platform was easily able to support the weight of two 6 V batteries (approximately 22.5 kg per battery), mount the solar panels, and hold the electrical components, which were safely covered from sun and rain exposure by the solar panel. However, although this is a very successful technique for habitats like a salt

marsh, constructing a table-like platform in thick mangrove cover is difficult, as a fair degree of mangrove trees and roots need to be cleared. Therefore, we altered our design to make simultaneous construction of 10 antennae more feasible.

Our altered design used a single 3.65 m long pressure-treated wood 150 cm x 150 cm pole as the centerpiece to a 'tower'. We set the post approximately 1 m into the ground for stability. We carved notches into the top of the pole to secure a pole-top mount for the solar panel; this mount is purchased with the solar panel, allows tilt adjustment (relative to the horizon), and allows fairly easy removal of the solar panel prior to approaching hurricanes. The height of the post allows the solar panel to receive ample light.

The junction box was attached to the post by screws or nails 0.5 - 1 m below the solar panel. Approximately 1 m from the ground, we attached a plywood platform for the batteries and buttressed the platform with pressure treated wood measuring 50 cm x 100 cm (Figure 1F). This platform provides support for the weight of the batteries, and allows the researcher to stand on the platform when working in the junction box or on the solar panel. Batteries were housed in high-quality vented plastic boxes (Figure 1F).

The pre-manufactured reader boxes (Figure 1E) are drip-proof, not waterproof, and must be further protected from the elements. We placed silicate desiccant packs within each reader to remove air moisture, and sealed the readers with electricians duct tape. We also created plastic covers to shade the reading units from the sun and direct rain. Better designs are suggested for future use; for example, readers could be placed within an insulated cooler, which may provide long-term protection.

Maintenance and Data Download

PIT tag antennae require little maintenance. Each battery needs to be refilled with distilled water at least every 3 - 4 months to ensure the lead cells are entirely covered. Battery terminals and connections must also be checked and cleaned for corrosion, especially when near saltwater environments. Deep-cycle batteries typically last for 3 - 6 years, after which they are no longer able to hold a charge and need to be replaced. Also, depending on conditions in the given environment, the inductor coil should be checked periodically for fouling organisms, displacement, or deformity. It is also important to check the read range of the system, as antennae require retuning on rare occasion.

Maintenance tasks are easily performed while downloading antenna data. Data download is best achieved with a waterproof PDA or field computer. If remote download is desired, mobile phone antenna units can be attached to reader units; this method requires equipment and monthly phone service fees, and requires that the antenna be in range of a mobile phone tower.

Regardless of download strategy, data is transferred as a text file containing basic information such as tag number, time of recapture, and date of recapture. This data is then easily sorted and manipulated in computer programs such as Excel and 'R.'

Demonstration System

In the summer of 2008 we deployed 11 PIT tag antenna in four tidal mangrove creeks in Charlotte Harbor, Florida (USA). These antennae recorded 362,880 PIT tag detections from August 2008 to August 2010. Starting in 2004, we marked 3,810 snook in these study creeks (2,297 were marked before and 1,513 after antenna construction); the majority (94%) of these fish were juveniles ≤ 320 mm standard length (SL). Since the antenna array was constructed, we recaptured 1,594 (41.8%) uniquely marked fish at least once: 1,267 of these recaptures were from the subset of 1,513 fish marked after antennae were constructed. This represents an 83.7% recapture for fish marked after construction, as opposed to 14.2% for fish marked before antenna construction.

In addition to the 3,810 snook marked in the creeks, we marked 2,603 adult snook on spawning beaches > 24 km west of the creeks from summer 2007 to summer 2009. Creek antennae recaptured nine of these fish, which is a low recapture rate, but provides valuable data allowing us to make inferences on habitat use and movement by adult snook. Additional inferences on adult use of the creeks can be made by using recapture information from adults marked within the creeks; juveniles marked in past years can also be included in this analysis, as information on growth rate can be used to determine when they have reached adult size.

Our application of autonomous PIT tag antennae is particularly useful for calculating apparent survival, due to the high probability of recapturing a recently marked fish. Using recapture data from our antennae array, we have been able to calculate apparent survival ($F = 1 - \text{mortality} - \text{emigration}$) and capture probability (p) using a Cormack-Jolly-Seber (Cormack 1964, Jolly 1965, Seber 1965) model as found in the computer program Mark (White and Burnham 1999). Using this model, we calculated apparent survival (Figure 4) and capture probability (Figure 5) with highly precise 95% confidence intervals on monthly periods for a population of 593 juvenile snook marked from November 2009 to February 2010. This level of temporal precision is extremely useful for monitoring and assessment purposes, as is shown by the significant decrease in apparent survival during the extreme cold period that struck Florida in January 2010 (Figure 4).

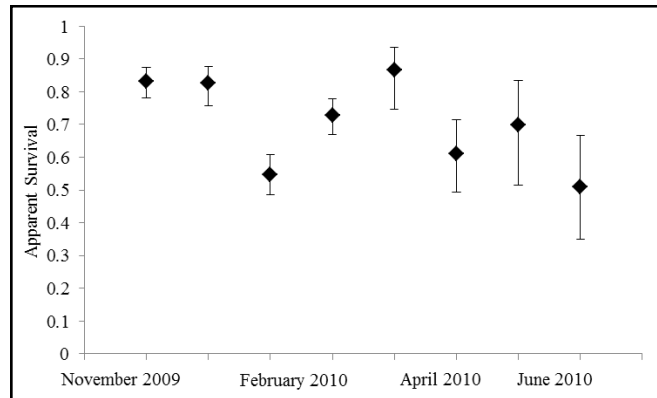

Figure 4. Apparent survival (F) of 593 juvenile common snook calculated with a Cormack-Jolly-Seber open population model. Apparent survival probabilities represent the probability of marked individuals to remain alive within the system from one month to the next. For example, the first parameter estimate represents the apparent survival from November 2009 to December

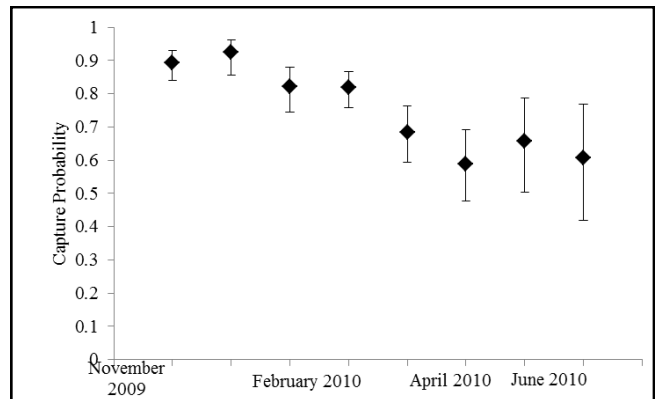

Figure 5. Capture probability (p) of 593 juvenile common snook calculated with a Cormack-Jolly-Seber open population model.

CONCLUSIONS

Autonomous PIT tag antennae are a promising technology for future use in monitoring and assessing marine and estuarine fisheries. The flexibility in antenna design allows for customization for each unique marine system, but detection range is limited by constraints on the inductor coil, making PIT tag antenna most useful in constricted water bodies (e.g. salt marshes, mangroves creeks, etc). The low cost of PIT tags allows for a high number of fish to be marked, and indefinite tag life permits lifelong marking. The highly efficient recapture system of autonomous PIT tag antennae, the long antenna life span (if properly maintained), and continuous recaptures combine to provide highly detailed data on habitat use and survival.

ACKNOWLEDGEMENTS

We thank D.R. and D.K. Gulnac for use of their facilities. We thank R. Boucek, N. Barkowski, H. Royal, J. Allen, M. Norman, S. Scott and several others for field assistance. This publication was supported by grants from: the National Sea Grant College Program of the U.S. Department of Commerce's National Oceanic and Atmospheric Administration (NOAA), Grant No. NA06-OAR4170014 to AJA; Charlotte Harbor National Estuary Program to AJA; Southwest Florida Water Management District to AJA; Mote Scientific Foundation to AJA; and by a National Science Foundation Graduate Research Fellowship to ABB.

LITERATURE CITED

- Adams, A.J., R.K. Wolfe, W.E. Pine III, and B.L. Thornton. 2006. Efficacy of PIT tags and an autonomous antenna system to study the juvenile life stage of an estuarine-dependent fish. *Estuaries and Coasts* **29**:311-317.
- Armstrong, J.D., V.A. Braithwaite, and P. Rycroft. 1996. A flat-bed passive integrated transponder antenna array for monitoring behavior of atlantic salmon parr and other fish. *Journal of Fish Biology* **48**:539-541.
- Barrowman, N.J. and R.A. Myers. 1996. Estimating tag-shedding rates for experiments with multiple tag types. *Biometrics* **52**:1410-1416.
- Beck M.W., K.L. Heck, K.W. Able, D.L. Childers, D.B. Eggleston, B.M. Gillanders, B. Halpern, C.G. Hays, K. Hoshino, T.J. Minello, R.J. Orth, P.F. Sheridan, and M.P. Weinstein. 2001. The identification, conservation, and management of estuarine and marine nurseries for fish and invertebrates. *BioScience* **51**:633-641.
- Cormack, R.M. 1964. Estimates of survival from the sighting of marked animals. *Biometrika* **51**:429-438.
- Gibbons, J.W. and K.M. Andrews. 2004. PIT tagging: a simple technology at its best. *BioScience* **54**:447-454.
- Heupel, M.R. and C.A. Simpfendorfer. 2002. Estimation of mortality of juvenile blacktip sharks, *Carcharhinus limbatus*, within a nursery area using telemetry data. *Canadian Journal of Fisheries and Aquatic Sciences* **59**:624-632.
- Hewitt, D.A., E.C. Janney, B.S. Hayes, and R.S. Shively. 2010. Improving inferences from fisheries capture-recapture studies through remote detection of PIT tags. *Fisheries* **35**:217-231.
- Jagiello, T.H. 1995. Abundance and survival of lingcod at Cape Flattery, Washington. *Transactions of the American Fisheries Society* **124**:170-183.
- Jolly, G.M. 1965. Explicit estimates from capture-recapture data with both death and immigration-stochastic model. *Biometrika* **52**:225-247.
- Meynecke, J.O. G.C. Poole, J. Werry, and S.Y. Lee. 2008. Use of PIT tag and underwater video recording in assessing estuarine fish movement in a high intertidal mangrove and salt marsh creek. *Estuarine, Coastal and Shelf Science* **79**:168-178.
- Prentice, E.F., T.A. Flagg, C.S. McCutcheon, and D. Brastow. 1990. PIT-tag monitoring systems for hydroelectric dams and fish hatcheries. *American Fisheries Society Symposium* **7**:323-334.
- Seber, G.A.F. 1965. A note on the multiple-recapture census. *Biometrika* **52**:249-259.
- Tsukamoto, K. 1985. Mass-marking of Ayu eggs and larvae by tetracycline-tagging of otoliths. *Bulletin of the Japanese Society of Scientific Fisheries* **51**:903-911.
- Wheeler, J.P. and G.H. Winters. 1984. Homing of Atlantic herring (*Clupea harengus harengus*) in Newfoundland waters as indicated by tagging data. *Canadian Journal of Fisheries and Aquatic Sciences* **41**:108-117.
- White, G.C. and K.P. Burnham. 1999. Program MARK: survival estimation from populations of marked animals. *Bird Study* **46**:120-139.