

### 5.3.5 Calculations of the shore retreat rate using thermoterrace dimensions

*Feliks E. Are, Mikhail N. Grigoriev, Hans-W. Hubberten and Volker Rachold*

#### 5.3.5.1 Introduction

Station 11 was chosen on the south coast of the Dmitry Laptev Strait (Fig. 5.3.5-1) where thermoterraces are wide spread. Geodetic measurements of shoreline and coastal bluff edges were carried out on this station. Three kilometers of the coast were measured. Well-developed singlestage and doublestage thermoterraces in ice complex are widespread along the section measured (Fig. 5.3.5-2). It was the first time during four seasons of fieldwork (1999-2002) that coastal group gained an opportunity to measure thermoterraces.

Thermoterraces in the ice complex represent a unique feature of coastal geomorphology, because their dimensions keep quantitative information on the time of their existence and may be used for calculation of the mean shore retreat rate during this time (Are, 1968, 1985, 1988).

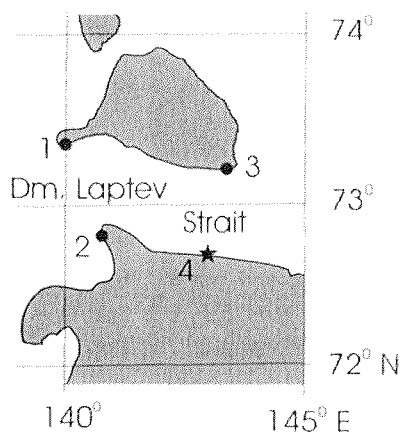

**Figure 5.3.5-1.** Location of Station 11. Polar Stations: 1 – Kigilyakh, 2 - Cape Svyatoy Nos, 3 – Cape Shalaurova; Station 11 – 4.



**Figure 5.3.5-2.** A singlestage thermoterrace on Station 11.

## 5.3.5.2 Measurements

Cross-profiles of four separate thermoterraces were measured on the Station 11 on August 30. In Fig. 5.3.5-3 a profile of a doublestage thermoterrace is shown as an example. Positions of points 1-5 measured with a laser theodolite as related to the origin of coordinates shown in Fig. 5.3.5-3 are given in Table 5.3.5-1. On the upper cliff surface (1-2 in Fig. 5.3.5-3) the ice wedges are exposed. Between points 3 and 4 the thermoterrace surface is flat, covered with meadowy vegetation and entirely stable. Between points 2 and 3 there is a transition zone between exposed ice surface and vegetated surface. The ice surface here is covered with tundra vegetation blocks sliding down. In the upper part there are single separated blocks. In the lower part the ice surface is entirely covered. Profile of the surface between points 2 and 3 is concave. Thawing of the underlying ice complex and corresponding thaw subsidence are taking place.

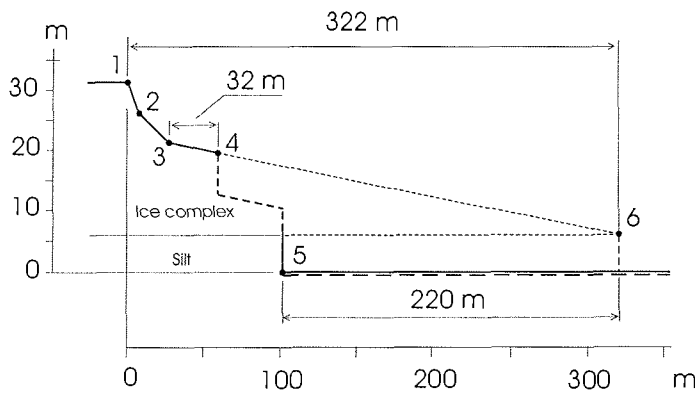

**Figure 5.3.5-3.** Profile of a doublestage thermoterrace on Station 11. 1 – upper cliff edge, 2 – upper cliff base, 3 – upper limit of thermoterrace stabilised surface, 4 – thermoterrace edge, 5 – lower cliff edge.

The thermoterrace profile between points 4 and 5 was not measured. Point 5 represents position of the lower cliff base. This cliff at the time of measurements was plumb with open wave niches at the base. Point 5 corresponds approximately with the highest sea level.

**Table 5.3.5-1:** Positions of points 1-5 measured with a laser theodolite as related to the origin of coordinates shown in Fig. 5.3.5-3.

Point number	Height	Distance
	m	
1	31.4	0
2	26.3	7.1
3	21.5	26.5
4	19.8	58.8
5	0	101.1

It is important that the ice complex base in the area of thermoterrace location is situated above the sea level. A thickness of silt with low ice content occurs below the ice complex. The edges of erosion cliffs composed of similar frozen sediments do not retreat far under the action of thermodenudation. Therefore the silt thickness does not take part in the thermoterrace formation, but its elevation above the sea level has to be taken into account by calculations of shore retreat rate using thermoterrace dimensions. Unfortunately the mark of the silt thickness top was not measured near the thermoterrace shown in Fig. 5.3.5-3. The measurements were carried out 540 m to the west (+8 m) and 1620 m to the east (0 m). The mark of the silt thickness top in the thermoterrace area +6 m was obtained using linear interpolation.

#### 5.3.5.3 Calculations of the shore retreat rate

For calculation of the shore retreat rate the flat stable part (3-4) of the thermoterrace surface was used. The straight line 3-4 is extended offshore until the intersection with the ice complex base level in the point 6. It is the place, where the upper cliff 1-2 was created in the past by a storm. After that the erosion rate of the coast was less than thermodenudation rate of the cliff. Therefore the cliff retreated faster than the shoreline. Until now the upper cliff retreated for 322 m from the point 6 (Fig. 5.3.5-3). The shoreline during the same time retreated for 220 m.

The thermodenudation rate of an ice complex may be calculated using the mean annual sum of positive average daily air temperatures ( $\Sigma t$  for brevity) (Are, 1985). The mean values of  $\Sigma t$ , measured on polar stations, are available for the time before 1961 (Izyumenko, 1966). The polar stations nearest to the Station 11 are Cape Svyatoy Nos, Kigilyakh and Cape Shalaurova (Fig. 5.3.5-1). The last two are located on the B. Lyakhovsky Island. The  $\Sigma t$  values measured on Laptev Sea islands are much less than that measured on the coast. Therefore we will use the sum for Svyatoy Nos p/s, which equals 345 °C-days (Izyumenko, 1966).

First we have to calculate the existence time of the upper cliff 1-2. During this time the cliff edge retreated for 322 m from point 6 to point 1 under the influence of thermodenudation (Fig. 5.3.5-3). The rate of thermodenudation (TDR, m/year) may be taken from the diagram presented in Fig. 5.3.5-4, or directly calculated by the empirical formula, which is based on the diagram (Are, 1985)

$$\text{TDR} = -3 \times 10^{-6} \cdot (\Sigma t)^2 + 98 \cdot 10^{-4} \cdot (\Sigma t) + 1.22 \quad (1)$$

For  $\Sigma t = 345$  °C-days, TDR = 4.25 m ice per year.

TDR is the thickness of ice layer thawed during a year. It is equal with the annual rate of cliff edge retreat (CER) for a plumb cliff. But for an inclined cliff CER is larger than TDR. It can be easily seen in Fig. 5.3.5-5. The relation between CER and TDR is as follows

$$\text{CER} = \text{TDR} / \sin \varphi. \quad (2)$$

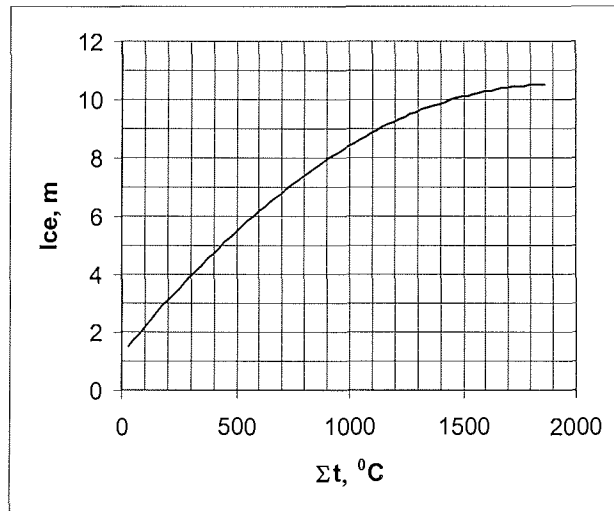

**Figure 5.3.5-4.** Thermodenudation rate of the vertical erosion cliffs, composed of ice complex, versus mean annual sum of positive average daily air temperatures (Are, 1985).

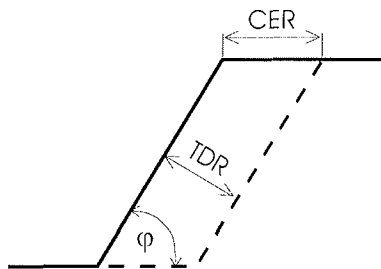

**Figure 5.3.5-5.** A schema showing retreat rate of inclined cliff edge (CER) and thermodenudation rate (TDR) of the same cliff.

According to the data presented in Fig. 5.3.5-3 and in Table 5.3.5-1, the upper cliff of the thermoterrace measured is inclined under the angle

$$\operatorname{tg} \varphi = 5.1 \text{ m} / 7.1 \text{ m} = 0.7183 \Rightarrow \varphi = 35.7^\circ$$

In principle the primordial cliff in point 6 was plumb. Let us assume approximately that the cliff slope decreased with time linearly. Then the average  $\varphi = (90 + 35.7) / 2 = 62.85^\circ$  and  $\text{CER} = 4.25 / \sin 62.85 = 4.78 \text{ m/year}$ .

The time of existence of the upper cliff (EXT)

$$\text{EXT} = 322 \text{ m} : 4.78 \text{ m/year} = 67 \text{ years.}$$

During this time the lower cliff (point 5 in Fig. 5.3.5-3) retreated for 220 m. The mean rate of retreat (shore erosion rate) during the same time was

$$\text{SER} = 220 \text{ m} : 67 \text{ years} = 3.3 \text{ m/year.}$$

#### 5.3.5.4 Discussion

The measurements and calculations described above prove that dimensions of thermoterraces may be used for calculations of shore retreat rate indeed. The rate values obtained using this technique are very probable. The next step to justify their reliability and to check the accuracy of calculations should be a comparison of calculated retreat rates with measured rates or with the rates obtained by means of comparison of aerial photographs or space images taken with possibly large time interval.

The working time of coastal group on Station 11 was limited by several hours. Measurements of thermoterraces were carried out on the side of the general geodetic survey of the coast. Therefore these measurements were insufficiently thorough. The constant inclination of thermoterrace surface is a crucial morphological feature for calculation of shore retreat rate. This feature may be clearly observed from a sufficient distance. But generally flat surface of the terrace shows itself on the background of a sometimes rather complicated microrelief. Therefore to obtain reliable results the points of geodetic measurements on the thermoterraces have to be chosen very carefully and several profiles across one and the same thermoterrace have to be measured. Especially important is the measurement of the upper cliff profile slope because thermodenudation rate strongly depends on it (Fig. 5.3.5-5).

## 5.4 References

- Are, F.E. (1968): Development of the relief on thermoabrasion coasts. Transactions of AS USSR, Geography Series, No. 1, p. 92-100 (in Russian).
- Are, F.E. (1985): Principles of shore thermoabrasion forecast. Novosibirsk: Nauka, 172 p.
- Are, F.E. (1988): Thermal abrasion of sea coasts. Polar Geography and Geology, Vol. 12, No. 1-2, V.H. Winston & Sons, 157 p.
- Are, F.E. (1999): The role of coastal retreat for sedimentation of the Laptev Sea. In: Kassens H. et al. (ed.), Land-Ocean Systems in the Siberian Arctic. Dynamics and History. Springer-Verlag, pp. 287-295.
- Are, F.E., Hubberten, H.-W., Rachold V., Reimnitz, E., and Solomon, S. (2002): Mathematical description of erosional shoreface profiles in the Arctic seas. Terra Nostra, Heft 2002/3. Climate drivers of the North. Selbstverlag der Alfred-Wegener-Stiftung, Berlin, p. 23-24.
- Drachev, S.S.; Savostin, L.A.; Groshev, V.G. & Bruni, I.E. (1998): Structure and geology of the continental shelf of the Laptev Sea, Eastern Russian Arctic.- Tectonophysics, 298: 357-393.
- Everdingen van, R.O. (ed.) (1998): Multi-Language Glossary of permafrost and related ground ice terms. International Permafrost Association, University of Calgary.
- Franke, D.; Krüger, F. & Klünger, K. (2000): Tectonics of the Laptev Sea – Moma "Rift" Region: Investigations with seismologic broadband data.- journal of Seismology, 4: 99-116.
- Gravis, G.F. (1978): Cyclicity of thermokarst at the coastal lowlands during the late Pleistocene and Holocene.- In: Publications of the 3<sup>rd</sup> International Permafrost Conference, July 10-13 1978, Edmonton, Alberta, Canada; Volume 1: 283-287.
- Grigoriev, M.N., and V.V. Kunitsky (2000) Ice Complex of Yakutian Arctic Coast as a Sediment Source on the Shelf: Hydrometeorological and Biogeochemical Studies in the Arctic. Vladivostok: Arctic Regional Center, Far-Eastern Branch RAS, Vol. 2, pp. 109-116 (in Russian).
- Inman, D.L., Elwany, M.H. and Jenkins, S.A. (1993): Shore rise and bar-berm on ocean beaches. Journal of Geophysical Research, 98, p. 18 181-18 199.
- Ivanenko, G.V. (1998): State geological map of Russian Federation, New Siberian Islands, 1:1,00,000, map of Quaternary formations.- Ministry of Natural Resources of Russian Federation
- Ivanov, O.A. (1972b): Stratigraphy and correlation of Neogene and Quaternary deposits of subarctic plains in Eastern Yakutia.- In: Problemes of the study of Quaternary Period.- Moscow, Nauka, pp. 202-211 (in Russian).
- Izyumenko S.A. Ed. (1966) Handbook on USSR climate, Part 24, Leningrad, Hydrometeoizdat, 398 p.
- Kaplina, T.N. & Lozhkin, A.V. (1985): Age and History of Accumulation of the "Ice Complex" of the Maritime Lowlands of Yakutiya. – In: Late Quaternary Environments of the Soviet Union. – Minneapolis: Univ. Minnesota Press, pp. 147-151.
- Kayalainen, V.I. & Kulakov, Yu.N. (1966): To the questions of Paleogeography of the Yana-Indigirka coastal lowland during the Neogene-Quaternary period.- In: Quaternary Period in Siberia.-Moscow, Nauka, pp. 274-283 (in Russian).
- Konishev, V.N.; Kolesnikov, S.F. (1981): Specialities of structure and composition of late Cenozoic deposits in the section of Oyogosky Yae.- In: Problems of cryolithology; VII IX, Moscow, MGU Publishing, p. 107-117 (in Russian).
- Kos'ko, M.K.; Lopatin, B.G. & Gamelin, V. G. (1990): Major geological features of the islands of the East Siberian and the Chukchi Seas and the northern coast of Chukotka.- Mar. Geol. 93: 349-367.
- Krasny, L. I. (ed.)(1981): Geology of Yakutian ASSR.- Moscow, Nedra, 300 pp. (In Russian).
- Kunitsky, V.V. (1998): Ice Complex and cryoplanation terraces of Bol'shoy Lyakhovskiy Island.- In: Kamensky, R.M., Kunitsky, V.V., Olovin, B.A. & Shepelev, V.V. (eds.): Problems of Geocryology – collected paper.- Russian Academy of Science, Siberian Branch, permafrost Institute Yakutsk, pp. 210.

- Kunitsky, V.V. & Grigoriev, M.N. (2000): Boulders and cobble roundstones near the Svyatoy Nose Cape and on Big Lyakhovsky Island. – In: Fourth QUEEN Workshop, Lund, Sweden, 7-10 April 2000. – Abstracts, p. 62.
- Kunitsky, V.V. (1996): Chemical content of ice wedges of the ice complex. – In: Development of the Cryolithozone of Eurasia during the upper Cenozoic. – Yakutsk, Permafrostinstitut Publ., 93-117 (in Russian).
- Lopatin, V.G. (ed.) (1998): State geological map of Russian Federation, New Siberian Islands, 1:1,00,000, map of Pre-Quaternary formations. – Ministry of Natural Resources of Russian Federation
- Moriizumi, J., Iida, T. & M.Fukuda (1995): Radiocarbon dating of methane obtained from air in the ice complex (Edoma), in Arctic coast area of east Siberia. – In: Proceedings of the Third symposium on the joint Siberian Permafrost between Japan and Russia in 1994. – Sapporo: Hokkaido Univ. Press, pp. 14-21.
- Meyer, H.; Dereviagin, A. Yu.; Siegert, C. & Hubberten, H.-W.: Paleoclimate studies on bykovsky peninsula, north Siberia – hydrogen and oxygen isotopes in ground ice. – Polarforschung. - 70: 37-51.
- Nagaoka, D., Saijo, K. & M.Fukuda (1995): Sedimental environment of the Edoma in high Arctic eastern Siberia. – In: Proceedings of the Third Symposium on the Joint Siberian Permafrost between Japan and Russia in 1994. – Sapporo: Hokkaido Univ. Press, pp. 8-13.
- Nikolaev, V.I., Genoni, L., Iacumin, P., Longinelli A., Nikolsky, P.A. & Sulerzhitsky, L.D. (2000): Isotopic studies of the Late Pleistocene megafauna in Northern Eurasia. – Moscow: Institute of Geography RAS. – 94 p. (in Russian).
- Nikolsky, P.A.; Basilyan, A. Ye.; Simakova, A.N. (1999): New stratigraphical data of upper Cenozoic deposits in the area of Cape Svyatoy Nos (coast of the Laptev Sea). – In: Landscape-climate change, fauna and man during Late Pleistocene and Holocene. – Moscow, IGRAN, p. 51-60 (in Russian).
- Parfenov, L., M. (ed.) (2001): Tectonics, Geodynamics and Metallogenesis of the area of the Republic Sakha (Yakutiya). – Moscow, "Nauka/Interperiodika", pp. 571.
- Pfeiffer E.-M., Grigoriev, M. N. (Eds.) (2002): Russian-German Cooperation SYSTEM LAPTEV SEA 2000: The Expedition LENA 2001. Reports on Polar and Marine Research 426.
- Prokhorova, S.M. & Ivanov, O.A. (1973): Tin-bearing granitoids of the Yana-Indigirka-Lowland and associated alluvial deposits. – Reports of NIIGA, volume 165. Leningrad, "Nedra", pp. 232.
- Rachold, V., Grigoriev, M.N. (Eds.) (1999): Russian-German Cooperation System Laptev Sea 2000: The Lena Delta 1998 Expedition, Reports on Polar Research, 315.
- Rachold V., Grigoriev, M.N. (Eds.) (2000): Russian-German Cooperation SYSTEM LAPTEV SEA 2000: The Expedition Lena Delta 1999. Report on Polar Research, 354.
- Rachold, V., Grigoriev, M.N. (Eds.) (2001): Russian-German Cooperation SYSTEM LAPTEV SEA 2000: The Expedition LENA 2000. Reports on Polar and Marine Research 388.
- Schirrmeister, L., Siegert, C., Kuznetsova, T., Kuzmina, S., Andreev, A.A., Kienast, F., Meyer, H., Bobrov, A.A. (2002). Paleoenvironmental and paleoclimatic records from permafrost deposits in the Arctic region of Northern Siberia, Quaternary International 89: 97-118.
- Siegert, C., Schirrmeister, L., Babiy, O. (2002). The Sedimentological, Mineralogical and Geochemical Composition of Late Pleistocene Deposits from the Ice Complex on the Bykovsky Peninsula, Northern Siberia, Polarforschung, 70: 3-11.
- Spektor, V.B. (1981): Tectonics of the New Siberian-Chukchi Fold Belt. – Sovetskaya Geologiya, 6: 102-105 (in Russian).
- Tomirdiaro, S.V. (1980): Loess-glacial formation of east Siberia during Late Pleistocene and Holocene. – Moscow, Nauka, 184 pp. (in Russian).
- Tomirdiaro, S.V. (1970): Eolian-cryogene origin of Yedoma-Complex deposits of North-east USSR. In: Abstracts of the allunion permafrost conference; Moscow, MGU Publishing, p. 106-107 (in Russian)
- Vereshagin, V.N. (ed.) (1982): Stratigraphical dictionary USSR. Palaeogene, Neogene, Quaternary system. – Moscow, Nauk, 128 p. (in Russian)