

CLONING AND EXPRESSION OF A THERMOSTABLE α -AMYLASE GENE FROM
STREPTOMYCES THERMOVIOLACEUS CUB74

A Thesis submitted for the Degree of Doctor of Philosophy of the
University of London.

by

Sami Mahmoud Bahri
Department of Biochemistry
University College London

ProQuest Number: 10608842

All rights reserved

INFORMATION TO ALL USERS

The quality of this reproduction is dependent upon the quality of the copy submitted.

In the unlikely event that the author did not send a complete manuscript and there are missing pages, these will be noted. Also, if material had to be removed, a note will indicate the deletion.



ProQuest 10608842

Published by ProQuest LLC (2017). Copyright of the Dissertation is held by the Author.

All rights reserved.

This work is protected against unauthorized copying under Title 17, United States Code
Microform Edition © ProQuest LLC.

ProQuest LLC.
789 East Eisenhower Parkway
P.O. Box 1346
Ann Arbor, MI 48106 – 1346

ACKNOWLEDGEMENTS

I am very grateful to my supervisor Dr John M Ward for his help and advice. I thank the people working in the laboratory for creating a friendly atmosphere. I also appreciate the constant companionship of my fiancée Ms Sara Zaman. I would also like to thank the Hariri Foundation for their financial support without which this work would have not been possible.

This work is dedicated to my parents who have supported me with affection and generosity throughout my education.

ABSTRACT

Streptomycetes are aerobic Gram-positive bacteria whose natural habitat is the soil. They have been of general interest because of their ability to produce a variety of secondary metabolites with antibiotic properties.

Apart from antibiotic production, streptomycetes produce many extracellular enzymes including amylases, proteases, cellulases and nucleases. Amylases are widely distributed amongst *Streptomyces* species and have been coming under increasing scrutiny in the past few years. For example, the α -amylase genes of *S. hygroscopicus*, *S. limosus* and *S. venezuelae* have been cloned and sequenced and their predicted amino acid sequences have been compared.

The thesis describes the cloning and expression of a thermostable α -amylase gene from *S. thermoviolaceus* CUB74 into *Escherichia coli* and *S. lividans*. When expressed in *E. coli*, the *Streptomyces* α -amylase enzyme was found in the periplasmic space and the supernatant. The extracellular enzyme isolated from the parent *Streptomyces* strain and the new hosts was further analysed by SDS-polyacrylamide gel electrophoresis. In addition, the product of starch digestion with this enzyme was analysed by paper chromatography. The α -amylase enzyme was reactivated in the SDS protein gel and its activity was visualized using a starch-agarose gel overlay. Stability of this enzyme at high temperatures was determined in the presence and absence of calcium and substrate. Its production in the parent strain and in *S. lividans* was also studied in the presence of different carbon sources. The gene specifying this enzyme was sequenced and its predicted amino acid sequence was compared with α -amylases isolated from other species. mRNA produced from this gene in different plasmid constructs was detected by Northern blotting and the transcriptional start site was determined by high resolution S₁ mapping.

CONTENTS	Page number
TITLE PAGE	1
ACKNOWLEDGEMENTS	2
ABSTRACT	3
CONTENTS	4
LIST OF TABLES	9
LIST OF FIGURES	10
CHAPTER ONE INTRODUCTION	12
<i>1.1 Life cycle and some important features of streptomycetes</i>	12
<i>1.2 Extracellular enzymes produced by Streptomyces</i>	14
<i>1.2.1 Amylase production by Streptomyces</i>	14
<i>1.2.2 Examples of other extracellular enzymes produced by Streptomyces</i>	17
<i>1.2.3 Examples of other extracellular enzymes produced by Streptomyces</i>	19
<i>1.3 Different classes of amylases and their uses</i>	19
<i>1.3.1 Endo-amylases (α-amylases)</i>	20
<i>1.3.1.1 Uses of endo-amylases</i>	22
<i>1.3.2 Exo-amylases</i>	23
<i>1.3.2.1 Glucoamylases</i>	24
<i>1.3.2.2 β-Amylases</i>	25
<i>1.3.3 Debranching enzymes</i>	25
<i>1.3.3.1 Pullulanases</i>	26
<i>1.3.3.2 Isoamylases</i>	26
<i>1.4 Thermostable α-amylases</i>	27
<i>1.4.1 Importance and uses of thermostable amylases</i>	27
<i>1.4.2 What is known about thermostability</i>	28

CHAPTER TWO MATERIALS AND METHODS	32
2.1 Bacterial strains and plasmids used in this thesis	33
2.2 Culture media and antibiotics	33
2.3 Maintenance of bacterial species	33
2.4 Isolation of total DNA	36
2.5 Preparing competent <i>E. coli</i> cells and their transformation with plasmid DNA	36
2.6 Plasmid isolation from <i>E. coli</i>	37
2.7 Preparation of <i>Streptomyces</i> protoplasts and their transformation with plasmid DNA	38
2.8 Plasmid isolation from <i>S. lividans</i>	39
2.9 Restriction enzyme digestions, ligations and agarose gels	40
2.10 DNA extraction from agarose gels	41
2.11 Making radioactive probes	41
2.12 Dephosphorylation of DNA	42
2.13 Southern blotting	43
2.14 Isolation of total mRNA from <i>Streptomyces</i>	44
2.15 Northern blotting	44
2.16 High resolution S ₁ mapping	45
2.17 Sequencing	46
2.17.1 Cloning in M13 prior to sequencing	46
2.17.2 Preparation of viral DNA	47
2.17.3 Annealing of primer to DNA	48
2.17.4 Sequencing reaction	49
2.18 Protein precipitation with ammonium sulphate	49
2.19 SDS-PAGE	50
2.20 Enzyme reactivation in the SDS-PAGE system	51

2.21 Paper chromatography	51
2.22 Cell fractionation	52
2.23 Alkaline phosphatase assay	52
2.24 α -Amylase assays	53
2.24.1 Somogyi assay	53
2.24.2 Turbidity assay	53
2.24.3 Plate assay	54
2.25 Total cell protein assay	54
CHAPTER THREE CLONING AND EXPRESSION OF A THERMOSTABLE	
α -AMYLASE FROM <i>STREPTOMYCES THERMOVIOLACEUS</i> STRAIN CUB74 IN	
<i>ESCHERICHIA COLI</i> JM107	55
3.1 Making a CUB74 total DNA library in pUC8 and cloning into <i>E. coli</i>	55
3.2 Results of Southern blotting	57
3.3 Restriction enzyme map of the 5.7kb BamHI insert	60
3.4 Results of subcloning experiments in <i>E. coli</i>	60
3.5 Expression of the cloned CUB74 α -amylase in <i>E. coli</i>	67
3.6 Localization of the cloned CUB74 α -amylase in <i>E. coli</i>	69
3.7 Effect of IPTG on amylase production by <i>E. coli</i> pQR300	69
3.8 SDS-PAGE	71
3.9 Summary	73
CHAPTER FOUR CHARACTERIZATION OF THE α -AMYLASE ENZYME	
4.1 Paper chromatography analysis of starch digestion with CUB74 amylase	77
4.2 Temperature optimum	79
4.3 pH optimum	79
4.4 Thermostability of the α -amylase	81

4.4.1 Effect of temperature on enzyme activity	81
4.4.2 Effect of calcium on thermal stability of α -amylase	84
4.4.3 Effect of substrate on thermal stability of α -amylase	84
4.4.4 Effect of calcium and substrate combined on thermal stability of α -amylase	84
4.5 Inhibition assay	87
4.6 Summary	89
CHAPTER FIVE CLONING AND EXPRESSION OF <i>STREPTOMYCES</i> <i>THERMOVIOLACEUS</i> (CUB74) α -AMYLASE GENE IN <i>S. LIVIDANS</i> TK24	
5.1 Subcloning in pQR1 and pIJ702 and expression in <i>S. lividans</i>	90
5.2 SDS-PAGE	97
5.3 Regulation of CUB74 α -amylase in <i>S. lividans</i>	100
5.3.1 Subcloning in the low copy-number plasmid pIJ903	100
5.3.2 Results of α -amylase induction in <i>S. lividans</i> and <i>S. thermoviolaceus</i>	104
5.3.3 Effect of carbon source on α -amylase production in <i>S. thermoviolaceus</i> (CUB74)	106
5.4 Summary	108
CHAPTER SIX NUCLEOTIDE SEQUENCE AND CHARACTERIZATION OF <i>S. THERMOVIOLACEUS</i> (CUB74) α -AMYLASE GENE	
6.1 Results of preparing single-stranded DNA templates	110
6.2 Results of preparing double-stranded DNA templates	112
6.3 DNA sequence analysis of α -amylase gene	114
6.4 Amino terminal sequence of CUB74 α -amylase	118
6.5 Comparison between the amino acid sequence of <i>S.</i>	

<i>thermoviolaceus</i> CUB74 α -amylase and those of other <i>streptomycete</i> α -amylases	121
6.6 Comparison between extracellular forms of the <i>S.</i> <i>thermoviolaceus</i> and the porcine pancreatic α -amylases	125
6.7 Results of Northern blotting	127
6.8 Results of high resolution <i>S</i> ₁ mapping	130
6.9 Summary	134
CHAPTER SEVEN GENERAL DISCUSSION	135
7.1 Expression of CUB74 α -amylase in <i>E. coli</i>	136
7.2 Molecular weight determination of α -amylase in <i>E. coli</i> and <i>Streptomyces</i>	138
7.3 Expression of cloned α -amylase in <i>S. lividans</i>	139
7.4 Regulation of α -amylase in <i>Streptomyces</i>	142
7.5 Characterization of α -amylase	146
7.6 DNA sequence of α -amylase gene and analysis of its regulatory region	148
7.7 Homology comparison of CUB74 α -amylase with those of other species	150
7.8 Conclusions	153
REFERENCES	156
PUBLICATIONS	175
Appendix 1	176
Appendix 2	177
Appendix 3	178
Appendix 4	179
Appendix 5	180

LIST OF TABLES	Page number
Table 2.1 Bacterial strains and plasmids used in this thesis	34
Table 2.2 Antibiotic concentrations in the media used	35
Table 3.1 Amylase localization in <i>E. coli</i> pQR300	70
Table 3.2 IPTG effect on amylase production by <i>E. coli</i> pQR300	72
Table 3.3 Summary of plasmid constructs obtained from subcloning experiments in <i>E. coli</i>	76
Table 4.1 Effect of temperature on α -amylase activity	83
Table 4.2 Effect of starch on its own and together with calcium on thermal stability of α -amylase	86
Table 4.3 Tendamistat assay	88
Table 5.1 Results of induction in <i>S. thermoviolaceus</i> CUB74	105
Table 5.2 Results of induction in <i>S. lividans</i> pQR319	107
Table 5.3 Carbon source effect on α -amylase production in CUB74	109
Table 6.1 Mapping of nested-deleted DNA	116
Table 6.2 Composition of the α -amylase codon sequence	117
Table 6.3 Distribution of codons in the CUB74 α -amylase open reading frame	122
Table 6.4 Amino acid sequence identity between CUB74 and some other known α -amylases	126
Table 7.1 Comparison between different <i>Streptomyces</i> promoter sequences	141

LIST OF FIGURES	Page number
Fig.1.1 A schematic diagram of starch and different amylases	21
Fig.3.1 Construction of CUB74 DNA library in pUC8	56
Fig.3.2 Comparison between amylase zones produced by <i>E. coli</i> pQR300 and <i>E. coli</i> pUC8 (control)	58
Fig.3.3 Southern blotting	59
Fig.3.4 Examples of single restriction enzyme digests of plasmid pQR300	61
Fig.3.5 Restriction enzyme map of pQR300	62
Fig.3.6 Construction of plasmids pQR301 and pQR304	63
Fig.3.7 Construction of plasmid pQR307	65
Fig.3.8 Construction of plasmids pQR312, pQR313, and pQR314	66
Fig.3.9 Construction of plasmid pQR303	68
Fig.3.10 SDS-PAGE	75
Fig.4.1 Paper chromatography	78
Fig.4.2 Temperature optimum of amylase	80
Fig.4.3 Effect of pH on enzyme activity	82
Fig.4.4 Effect of calcium on thermal stability of amylase	85
Fig.5.1 Construction of plasmids pQR308 and pQR309	91
Fig.5.2 Construction of plasmid pQR311	94
Fig.5.3 Comparison between amylase zones produced by <i>S. lividans</i> pQR311 and <i>S. lividans</i> pIJ702	95
Fig.5.4 Construction of plasmid pQR318	96
Fig.5.5 Comparison between amylase zones produced by <i>S. lividans</i> pQR318 and pQR1 (control)	98
Fig.5.6 SDS-PAGE	99
Fig.5.7 Construction of plasmid pQR319	101

Fig.5.8 Construction of plasmids pQR322 and pQR323	102
Fig.5.9 Comparison between amylase zones produced by <i>S. lividans</i> pQR322, pQR323 and pIJ903 (control)	103
Fig.6.1 An example of analysis of single-stranded DNA templates on an agarose gel	111
Fig.6.2 Construction of plasmids pQR315, 321 and 324	113
Fig.6.3 Results of nested-deletions experiment	115
Fig.6.4 Nucleotide sequence of the α -amylase gene (<i>amy</i>)	119
Fig.6.5 Comparison between the promoter sequence of <i>S. thermoviolaceus</i> amylase gene and those of <i>S. limosus</i> and <i>S. venezuelae</i>	123
Fig.6.6 Optimal alignment of the aa sequence of four streptomycete α -amylases	124
Fig.6.7 Comparison between the extracellular forms of the <i>S. thermoviolaceus</i> and pig pancreatic α -amylases	128
Fig.6.8 Northern blotting	129
Fig.6.9 High resolution S ₁ mapping	131
Fig.6.10 Promoter sequence (pQR318P) in pQR318	133
Fig.7.1 Amylase zones produced by <i>S. lividans</i> pQR318 when cultivated at 37°C	143

Starch is widely distributed in nature and constitutes an essential source of carbon (in addition to cellulose) which maintains many forms of life. It consists of two components, amylose and amylopectin. Amylose is a linear polymer of glucose units linked in an α -1,4 manner with a chain length of up to a thousand (Fogarty and Kelly, 1979). It accounts for 20-27% of corn starch, 20-22% of potato starch, and 0-5% of waxy starch. Amylopectin is a branched polymer, through α -1,6 bonds, and composed of chains of about 20-25 α -1,4 linked glucose residues. α -1,6 glucosidic bonds constitute 4-5% of the total bonds in this branched structure. Amylopectin constitutes 75-85% of most starches.

Enzymes that are able to degrade starch are called amylases and can be divided into three groups: exo-amylases, debranching enzymes, and by far the most common α -amylases or endo-amylases.

Amylases are produced by animals, plants, and microbes. Microbes are widely used for production and study of amylases and structure of starchy materials. For the purpose of this thesis, production of amylases by streptomycetes will be mainly discussed. In addition, different classes of amylases and some of their characteristics, especially those of α -amylases, will be described.

1.1 Life cycle and some important features of streptomycetes

Streptomycetes are Gram-positive aerobic soil bacteria possessing a tendency towards mycelial growth. *Streptomyces* are abundant in damp soil and are actively involved in decomposition such that large amounts of organic materials do not accumulate but recycle. None of

them causes disease in man or animals but one species (*S. scabies*) is a plant pathogen.

On solid media, *Streptomyces* possess two types of mycelial hyphae, substrate and aerial mycelia (Chater, 1984). Hyphae grow by tip extension and can be branched and subdivided by cross walls. Substrate mycelia, which appear early in the life cycle, grow into the solid medium and are able to extract nutrients by virtue of extracellular enzymes. Later in development, aerial mycelia are formed and maintained partly on nutrients released in the process of lysis of substrate mycelia. The aerial mycelia may then produce hydrophobic spores which are resistant to desiccation. *Streptomyces* spores have a distributive role which counteracts the immobility of the mycelial mass.

The size of the *Streptomyces* genome has been calculated to be 10000kb long, about 2.5x the size of the *E. coli* genome (Benigni *et al.*, 1975). The G+C content of most *Streptomyces* DNA is between 69 and 73% (Pridham and Tresner, 1974). Analysis of fundamental biology in streptomycetes has focused largely on *S. coelicolor* A3(2), the genetics of which are consequently fairly well understood (Hopwood *et al.*, 1973). *S. lividans* is closely related to *S. coelicolor* A3(2) but is less restricting towards foreign DNA than most other *Streptomyces* species. Moreover, the presence of broad promoter recognition and the ability to secrete some proteins have made *S. lividans* an alternative host to *E. coli* for *in vitro* genetic manipulation (Thompson *et al.*, 1982; Hopwood *et al.*, 1983).

Streptomyces have two highly important features, the production of antibiotics and the natural capacity for the secretion of

extracellular enzymes. The production of antibiotics coincides with the formation of aerial mycelia. More than 60% of natural antibiotics, described up to 1978, were of streptomycetes origin (Berdy, 1980). Many of the *Streptomyces* aspects mentioned above are covered in much greater detail in several reviews (Chater, 1984; Hopwood *et al.*, 1986). They will not be discussed any further since they are not directly relevant to the subject investigated in this study.

1.2 Extracellular enzymes produced by *Streptomyces*

Streptomyces produce many extracellular enzymes (Williams *et al.*, 1983). These include amylases, cellulases, nucleases, proteases, and a variety of other enzymes. The production of extracellular hydrolytic enzymes correlates with the adaptation of *Streptomyces* to the colonisation and dissolution of solid food sources by mycelia (Chater *et al.*, 1982).

Streptomyces extracellular enzyme genes have been targets for gene cloning experiments and physiological studies because of their potential for the development of secretion systems. In addition, they provide a good system to study gene regulation in this genus. The *Streptomyces* host also provides a convenient model for the study of secretion mechanisms and signals. *Streptomyces* may also prove to be useful hosts for the commercial production of cloned gene products since they are natural secretors.

1.2.1 Amylase production by streptomycetes

Extracellular α -amylase genes from three mesophilic *Streptomyces* species have recently been cloned and sequenced. An extracellular α -amylase gene (*amy*) has been isolated from *S. hygroscopicus* and cloned independently by two separate groups (Hoshiko *et al.*, 1987; McKillop

et al., 1986). The enzyme specified by this gene is probably used to some extent in industry in the Far East to hydrolyse starch to maltose. Hoshiko *et al.* (1987) purified the amylase to obtain amino acid sequence information which was used to synthesize oligonucleotide probes. Subcloning experiments indicated that *amy* could be expressed from the *lac* promoter in *E. coli* or from its own promoter in *S. lividans*. The 30-residue leader sequence of the enzyme showed similarities to leader sequences found in other prokaryotic extracellular enzymes. The purified α -amylase from *S. lividans* was indistinguishable by SDS-PAGE from the α -amylase produced by the parent strain, which indicated that correct processing had occurred when the enzyme was secreted by *S. lividans*.

An α -amylase gene from *S. limosus* has also been isolated and sequenced (Long *et al.*, 1987; Virolle and Bibb, 1988). The predicted amino acid sequence of this enzyme showed considerable identity to mammalian and invertebrate α -amylases but not to other bacterial, fungal, or plant α -amylases (Long *et al.*, 1987). It was assumed that this may reflect separate evolutionary origins for different α -amylases, with the mammalian, invertebrate, and streptomycete enzymes being derived from a common ancestral gene. Alternatively, the latter three may have originated from a common and more recent evolutionary branch point (Long *et al.*, 1987).

Regulation of the *S. limosus* enzyme was also investigated (Long *et al.*, 1987). In *S. limosus*, the enzyme was induced by maltose and repressed by mannitol whereas in *S. lividans* and *S. coelicolor*, it was induced by maltose and repressed by glucose. Induction and repression of amylase was found to occur at the transcriptional level.

The α -amylase gene of *S. venezuelae* has also been cloned and sequenced (Virolle *et al.*, 1988). This enzyme was transcribed from a promoter identical to that of *S. limosus* amylase and was found to be induced by maltose and repressed by glucose in *S. venezuelae*, *S. lividans* and *S. coelicolor*. Like *S. limosus* enzyme, regulation of *S. venezuelae* α -amylase was found to occur at the transcriptional level.

The predicted amino acid sequences of these three α -amylases were optimally aligned and found to be highly homologous (Virolle *et al.*, 1988). *S. limosus* and *S. venezuelae* α -amylases were inhibited by the mammalian α -amylase inhibitor tendamistat (Long *et al.*, 1987; Virolle *et al.*, 1988).

Amylolytic activity has also been reported from *S. albus* G (Andrews and Ward, 1987). In addition, a few thermostable amylases from *Thermoactinomyces* species have been characterized. A highly thermostable α -amylase from a *Thermoactinomyces* species (species 15) was partially purified and characterized by Obi and Odibo (1984). Its optimum activity is 80°C at pH7.0 and the enzyme retained 74% of its activity after 30min at 100°C. The products obtained from hydrolysis of native starches were glucose and maltose. The level of reducing sugars, along with the thermostability characteristics of the α -amylase of this species, indicated favourable properties of great potential in commercial starch saccharification. The α -amylase of *Thermoactinomyces vulgaris* has also been purified and found to have an optimum temperature of 70°C (Shimizu *et al.*, 1978). This enzyme can hydrolyse pullulan as well as starch and it was suggested that the enzyme carries a single catalytic site (Sakano *et al.*, 1982a; Sakano *et al.*, 1983). *Thermoactinomyces* are probably more closely related

to the thermophilic *Bacilli* than to true actinomycetes (Stanier *et al.*, 1977). An amylase from *Thermo^{mo}spora curvata* (a true actinomycete) has also been reported and found to produce mainly maltotetraose and maltopentaose (Glymph and Stutzenberger, 1977).

1.2.2 Regulation of amylase expression in streptomycetes

Regulation of α -amylase production is poorly understood but several phenomena are involved e.g. induction (Srivastava and Mathur, 1984), catabolite repression (Thirunavukkarasu and Priest, 1980), temporal activation (Nicholson and Chambliss, 1985), and mRNA stability (Gould *et al.*, 1973). Genetic studies of α -amylase have been carried out mostly in *Bacilli* and factors affecting the regulation of these enzymes have been reviewed by Priest (1977). However, little is known about gene regulation in general and catabolite repression in particular in streptomycetes, and attempts have been made to clone genes including the α -amylases which would permit studies of these phenomena in these industrially important bacteria. There have been so far only two reports on α -amylase regulation in streptomycetes. Virolle *et al.* (1988) reported that *S. venezuelae* α -amylase is repressed by glucose and induced by maltose in its natural host and when cloned in *S. lividans*. Virolle and Bibb (1988) reported that *S. limosus* α -amylase is induced by maltose and repressed by mannitol in its natural host whereas upon cloning into *S. lividans* and *S. coelicolor* the enzyme was found to be repressed by glucose in these *Streptomyces* species. It was suggested that the apparent insensitivity to glucose repression in *S. limosus* was not a property of the amylase gene itself but a characteristic of the producing bacterial strain. Glucose was found to repress several functions in *S. coelicolor*

including glycerol utilization (Seno and Chater, 1983), agar utilization (Hodgson, 1982; Bibb *et al.*, 1987), and uptake systems for arabinose and glycerol (Hodgson, 1982).

Induction of α -amylase by maltose occurred at the transcriptional level (Virolle and Bibb, 1988; Virolle *et al.*, 1988). The C-terminus of another ORF preceding the 5' end of *S. venezuelae* α -amylase gene was also sequenced (Virolle *et al.*, 1988). This region showed considerable amino acid sequence identity to the C-terminus of the *gal*⁻, *lac*⁻, and *ebg*-repressor proteins of *E. coli*. It was suggested that this ORF may encode a sugar-binding protein directly involved in regulating amylase expression (Virolle *et al.*, 1988).

It is not clear whether carbon source repression of amylase induction is mediated via a regulatory mechanism acting directly on the transcription of amylase or more indirectly by inducer exclusion, or by both. There is evidence to suggest that cAMP does not take part in glucose repression in streptomycetes (Demain *et al.*, 1983; Hodgson, 1982). Glucose repression of amylase expression in *S. coelicolor* was relieved in mutants deficient in ATP-dependent glucose kinase (Ikeda *et al.*, 1984). Glucose kinase has therefore been suggested to play a central role in glucose repression in streptomycetes but the mechanism of this phenomenon is not clear. In *E. coli*, the enzyme II^{glc}-enzyme III^{glc} complex (phosphotransferase system) effects both glucose uptake and phosphorylation and mediates its effects both by inducer exclusion and cAMP stimulation of catabolic genes (Postma and Lengeler, 1985; Postma, 1986). In *Saccharomyces cerevisiae*, hexokinase PII was suggested to possess both domains, catalytic by phosphorylating hexose and regulatory by mediating catabolite repression (Entian *et al.*,

1984; Entian and Frohlich, 1984). It is not known whether the role of glucose kinase in mediating glucose repression in *S. coelicolor* is similar to the regulatory role of *E. coli* or *Saccharomyces cerevisiae* system. It is also not known whether its involvement results from the production of a metabolite directly involved in the process.

1.2.3 Examples of other extracellular enzymes produced by

Streptomyces

Several extracellular enzyme genes from *Streptomyces* have been cloned and sequenced. These include an endoglycosidase H gene from *S. plicatus* (Robbins *et al.*, 1981; Robbins *et al.*, 1984), the β -lactamase gene (*bla*) of *S. albus* (Dehottay *et al.*, 1986; Dehottay *et al.*, 1987), the tyrosinase gene of *S. antibioticus* (Katz *et al.*, 1983; Bernan *et al.*, 1985), and an agarase gene from *S. coelicolor* A3(2) (Kendall and Cullum, 1984). In addition, a xylanase from *S. lividans* (Morosoli *et al.*, 1986) and proteolytic enzymes from *Streptomyces griseus* have been studied (Henderson *et al.*, 1987).

1.3 Different classes of amylases and their uses

The major substrate of amylases, starch, is a polysaccharide consisting of two components: a linear glucose polymer, amylose, which contains α -1,4 glucosidic links with an average chain length of up to a thousand glucose units, and a branched polymer, amylopectin. Amylopectin consists of linear chains of α -1,4 glucosidic residues with an average length of up to 20 to 25 glucose units which are interlinked by α -1,6 glucosidic linkages (Manners, 1974). It can be hydrolysed readily to produce syrups or solids containing glucose, maltose and other oligosaccharides. In industry, the hydrolysis of starch may be carried out using either acids (HCl or oxalic acid) or

enzymes. Acid, at pH2.0, hydrolyses starch in a random manner which leads to the production of several undesirable by-products such as anhydro-glucose compounds. Enzymatic hydrolysis, however, has several advantages over acid hydrolysis; it is more specific and fewer by-products are produced, so that yields are higher; it is also carried out under milder conditions so that subsequent refining stages to remove ash and colour are minimized (Norman, 1979).

There are three main classes of starch degrading enzymes: endo-amylases, exo-amylases, and debranching enzymes. A schematic diagram of amylopectin and action of some amyolytic enzymes is shown in Fig.1.1.

1.3.1 Endo-amylases (α -amylases)

Endo-amylases are generally α -amylases which cleave α -1,4 glucosidic bonds in amylose, amylopectin and related polysaccharides. They hydrolyse the bonds located in the inner regions of the substrate which results in a rapid decrease in the viscosity of starch solutions and a rapid decrease in the iodine staining power of amylose. The products of hydrolysis, which are oligosaccharides of varying chain lengths, have the α -configuration at the C, of the reducing glucose unit. Endo-amylases are also able to by-pass α -1,6 branch points in amylopectins (Robyt and Whelan, 1968). Some α -amylases are able to attack α -1,6 glucosidic linkages in certain α -1,4:1,6 glucooligosaccharides (Sakano *et al.*, 1983). There is apparently a spectrum of specificity within the α -amylases from those which only cleave the α -1,4 linkages, through to those with increasing ability to cleave α -1,6 bonds. The end products also differ amongst the α -amylases; many give a range of final products from glucose, maltose,

Fig.1.1 A schematic diagram of amylopectin and action pattern of some amylases. Glucose residues are indicated by circles and the sites of enzyme activity are indicated by arrows.

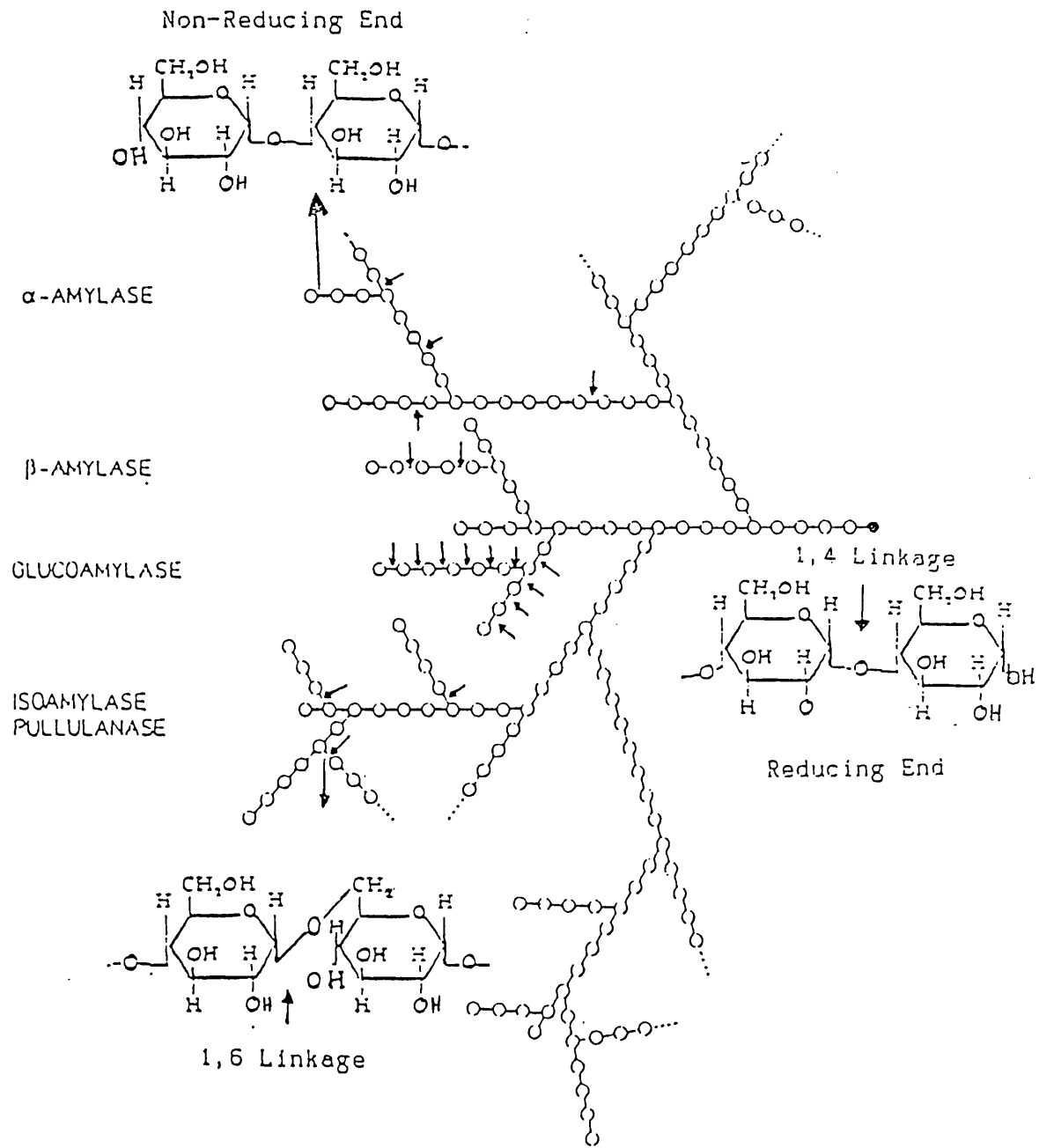

maltotriose, up to maltohexaose, as well as a series of α -limit dextrins. α -Amylases of *A. oryzae* (Minoda *et al.*, 1968), *B. stearothermophilus* KP1064 (Suzuki and Imai, 1985), *B. subtilis* G3 (Takasaki, 1985), and *T. vulgaris* (Shimizu *et al.*, 1978) produce mainly maltose. α -Amylases of *B. circulans* (Takasaki, 1983) and *B. subtilis* produce predominantly maltotetraose. The α -amylase of *B. circulans* G-6 initially produce mainly maltohexaose, which is hydrolysed further to maltose and maltotriose and then to maltose and glucose (Takasaki, 1982). *B. cereus* NY-14 (Yoshigi *et al.*, 1985), *B. licheniformis* (Saito, 1973), and *B. stearothermophilus* ATCC 12980 (Flanningan and Sellars, 1977) α -amylases produce mainly maltopentaose.

1.3.1.1 Uses of endo-amylases

The endo-amylases of industrial importance can be divided into thermostable α -amylases which are used mainly for high-temperature liquefaction, and thermolabile α -amylases which are used for saccharification. Starch suspension of 30% (w/v) is heated to 110°C to rupture the starch granules and because of its high viscosity, a thinning agent (liquefying enzymes) is ^{added} which apart from reducing viscosity also partially hydrolyses starch so that precipitation is prevented during subsequent cooling. Liquefying enzymes, such as the thermostable α -amylase of *B. licheniformis*, are applied at the initial stage of starch hydrolysis process which is carried out at high temperature (95-105°C) to produce oligosaccharides of varying chain length (maltose, maltotriose, maltopentaose, and α -limit dextrins). These oligosaccharides are hydrolysed further in the second stage, saccharification, at a lower temperature by the action of mesophilic

amylases to produce even smaller molecules such as maltose and glucose (Fogarty and Kelly, 1979).

α -Amylases of industrial uses are largely produced by many *Bacilli* species. *B. amyloliquefaciens* amylase is produced industrially. Vehmaanpera *et al.* (1987) reported that a genetically engineered *B. subtilis* strain (Alko 84) had been introduced for industrial amylase production. The most thermostable of all industrial enzymes is the α -amylase of *B. licheniformis*. This enzyme can liquefy starch at up to 110°C but it is not stable at this temperature and is completely inactivated after 15min incubation at 90°C (Saito, 1973).

In the saccharification process, the mesophilic α -amylase of *S. hygrosopicus* SF-1084 is reported to be used industrially in the Far East to hydrolyse starch to maltose (Hoshiko *et al.*, 1987).

1.3.2 Exo-amylases

Exo-amylases catalyse the hydrolysis of α -1,4 glucosidic bonds in amylose, amylopectin and related polysaccharides by successively removing low molecular weight products such as glucose or maltose from the non-reducing chain end in a stepwise manner. In contrast to the action of endo-amylases, this results in a slow decrease in the viscosity and iodine staining power of starch. The products of hydrolysis generally have the β -configuration at the C₁ of the reducing glucose unit (Robyt and Whelan, 1968). The two main groups of exo-amylases are glucoamylases which release glucose and β -amylases which release maltose in a stepwise manner from the non-reducing end of the molecule. In addition, there are exo-amylases which release maltotetraose (Schmidt and John, 1979) or maltohexaose (Kainuma *et al.*, 1975) by an exo-attack mechanism. Enzymes of *S. griseus* produce

mainly maltotriose, and *B. circulans* F-2 first maltohexaose which is then converted to maltotetraose and maltose (Taniguchi *et al.*, 1983). *P. stutzeri* enzyme produces maltohexaose and later also maltotetraose (Sakano *et al.*, 1982b). This enzyme possesses both endo- and exo-hydrolysing functions.

1.3.2.1 Glucoamylases

Glucoamylases are exoamylases that remove glucose units from the non-reducing end of sugar molecules by successive cleavage of the α -1,4 glucosidic bonds. They have a low degree of specificity and can hydrolyse α -1,3, which may also be present in starch and glycogen, and α -1,6 linkages in maltooligosaccharides, though at a slower rate than α -1,4 linkages (Pazur and Kleppe, 1962; Chapon and Raibaud, 1985). Glucoamylases are produced by many fungi, but only a few bacteria, including *B. stearrowthermophilus* (DePinto and Campbell, 1968), *Flavobacterium* sp. (Taniguchi *et al.*, 1986), and *Halobacterium sodomense* (Ohba and Ueda, 1982). They have commercial importance in starch degradation, production of glucose and fructose syrups, and ethanol. The rate of hydrolysis increases with the chain length of the substrate, which distinguishes glucoamylases from α -glucosidases which hydrolyse α -1,4 glucosidic links more rapidly in low molecular weight oligosaccharides and release glucose residues of α -configuration rather than β -configuration produced by glucoamylases (Manners, 1974).

α -Glucosidases or maltases are produced by many microorganisms. Enzymes of *Penicillium oxalicum* (Yamasaki *et al.*, 1977), *P. pupurogenum* (Yamasaki *et al.*, 1976), and *Tetrahymena pyriformis* (Banno and Nozawa, 1985) can degrade amylose and starch as well.

1.3.2.2 β -Amylases

β -Amylases are exoamylases that remove maltose units from the non-reducing end of sugar molecules by successive cleavage of the α -1,4 linkages. Some β -amylases contain sulphhydryl groups at the active sites and are therefore very sensitive to heavy metal ions and oxidizing agents. β -Amylases are produced by several microorganisms and mainly by the mesophilic class. Like plants, *B. megaterium* (Higashihara and Okada, 1974) and *B. cereus var. mycoides* (Takasaki, 1976) produce β -amylases which are inhibited by heavy metal ions as well as PCMB (*p*-chloromercuribenzoate). In contrast, β -amylases from *B. polymyxa* and *B. circulans* are not significantly inhibited by PCMB, indicating that sulphhydryl groups are not involved in their active sites.

β -Amylases are often used to produce high maltose syrups. However, unlike the syrup produced by α -amylases, the syrup produced by the β -amylase will contain a large amount of β -limit dextrins and less maltotriose. High maltose syrups normally contain 40-50% maltose, but in order to obtain "extra" high maltose syrups containing more than 80% maltose, it is necessary to use a maltogenic exo-amylase (β -amylase) and a debranching enzyme in combination.

1.3.3 Debranching enzymes

Most starches of industrial importance contain 75-85% amylopectin in which α -1,6 branch points account for 4-5% of the glucosidic linkages in the molecule (Fogarty and Kelly, 1979). The branch points containing α -1,6 glucosidic linkages are resistant to attack by α -amylases or β -amylases and their presence also imposes a certain degree of resistance on neighbouring α -1,4 linkages. Thus, α -limit

dextrins, in the case of α -amylases, which are branched oligosaccharides of four or more glucose units and contain all the α -1,6 linkages of the original polymer, and β -limit dextrins in the case of β -amylases, which are not susceptible to further hydrolysis, are formed (Robyt and Whelan, 1968). Some glucoamylases, on the other hand, are able to hydrolyse α -1,6 glucosidic links, but the reaction proceeds relatively slowly (Pazur and Ando, 1960).

1.3.3.1 Pullulanase

The debranching enzyme which has perhaps been most widely studied and which is being used on ^{an} industrial scale is pullulanase (Pullulan 6-glucanohydrolase EC 3.2.1.41). The pullulanase substrate, pullulan, is a linear polymer of α -1,6 linked maltotriosyl units (Catley *et al.*, 1966; Norman, 1979). The pullulanase enzyme is an α -1,6 glucosidase which specifically attacks the linear α -glucan pullulan releasing maltotriose and will also hydrolyse the α -1,6 glucosidic links in amylopectin and limit dextrins provided that there are at least two α -1,4 glucosidic links on either side of the α -1,6 links (Abdullah and French, 1970). They may thus have considerable potential to increase the efficiency of industrial enzyme-based starch saccharification.

There have been few reports of pullulanases from thermophiles (e.g. Suzuki and Chishiro, 1983; Hyun and Zeikus, 1985; Plant *et al.*, 1986). Amongst mesophilic pullulanases, the *Klebsiella* enzyme is the most extensively genetically studied pullulanase (Takizawa and Murooka, 1985; Michaelis *et al.*, 1985; Katsuragi *et al.*, 1987; d'Enfert *et al.*, 1987).

1.3.3.2 Isoamylase

Another type of debranching enzymes is isoamylase (amylopectin 6-

glucanohydrolase, EC 3.2.1.9) (Yokobayashi *et al.*, 1969; Harada *et al.*, 1972). The isoamylase isolated from *Pseudomonas* SB-15 (Yokobayashi *et al.*, 1973) differs from pullulanase in that it has a higher affinity for amylopectin and glycogen, but its activity towards pullulan is very low. Another significant difference is that the smallest substrate hydrolysed by isoamylase is a branched heptasaccharide whereas the smallest substrate for pullulanase is a linear tetrasaccharide. Isoamylases are not industrially important but their most important application is in structural studies.

1.4 Thermostable α -amylases

Thermostable α -amylases have several advantages over their mesophilic counterparts. They are especially important in industry. Importance of thermostable α -amylases and what is known about the thermostability phenomenon will be discussed.

1.4.1 Importance and uses of thermostable amylases

Thermostable amylases are especially important in industry since they can be applied at the high temperature required to rupture starch granules in the initial stage of starch hydrolysis. In ^{the} starch industry, α -amylase which is an endoenzyme cannot attack starch granules unless they have been ruptured by heat (gelatinization). Therefore, in the case of a mesophilic enzyme, the material has to be cooled down before any enzymic reaction can take place. However, a thermostable enzyme enables faster, cheaper, and more efficient starch liquefaction since the material does not have to be cooled after gelatinization for enzymic hydrolysis. Another benefit from operating at high temperatures is that microbial contamination of the material being processed is markedly reduced (Brock, 1986). A wide variety of

extracellular enzymes, which are generally heat stable, are produced by thermophilic microorganisms (for example, Singleton and Amelunxen, 1973; Ljungdahl, 1979). The highest temperature optimum is reported for the *B. licheniformis* α -amylase. The enzyme can liquefy starch at up to 110°C but it is not stable at this temperature (Saito, 1973). Of the actinomycetal enzymes, the highest temperature optimum (80°C) α -amylase is from *Thermoactinomyces* sp.15 (Obi and Odibo, 1984). The enzyme is remarkably thermostable and only loses 20% of its original activity after 30min incubation at 100°C.

1.4.2 What is known about thermostability?

The principal determinants of enzyme stability are non-covalent forces which are responsible for the protein secondary and tertiary structures whereas disulfide bonds are not considered to contribute significantly (Ponnuswamy et al, 1982). Enhanced thermostability is thought to be related to a combination of factors and reflects the amino acid sequence of proteins. These factors include formation of new ion pairs (Argos et al., 1979), hydrophobicity (Merkler et al., 1981; Frommel et al., 1981), metal binding (Hein and Lauwers, 1976), substrate binding (Pace and MacGrath, 1980), and glycosylation (Chu et al., 1978; Harris et al., 1980).

The difference in thermostability between glyceraldehyde-3-P-dehydrogenase from lobster and *B. stearrowthermophilus* is mainly due to inter-subunit ion pairing. In *B. stearrowthermophilus* glyceraldehyde-3-P-dehydrogenase, hydrophobic interactions contribute to the strong binding between subunits and are thought to contribute also to thermostability. Hydrophobicity in the internal part of glyceraldehyde-3-P-dehydrogenase from *Thermus aquaticus* is greater

than the *B. stearrowthermophilus* enzyme and the former enzyme is more thermostable (Harris *et al.*, 1980).

Replacement of asparagine-20 by aspartate in the tyrosinase of *Neurospora crassa* enhanced the thermostability of the enzyme and results in the formation of an additional ion pair (Ruegg *et al.*, 1982). Replacement of glutamate-49 by methionine to increase hydrophobic bonding increased the thermostability of tryptophan synthetase in *E. coli* (Yutani *et al.*, 1977).

Macroscopic parameters including hydrophobic index, the ratio of polar to non-polar volumes, the ratios of arginine/arginine plus lysine and arginine plus lysine to total amino acids, % hydrogen-bonding amino acids, and % α -helix- or β -sheet-forming amino acids were calculated by Merkler *et al.* (1981). They compared more than 20 enzymes and proteins from various closely related mesophilic and thermophilic microorganisms (especially *Bacillus*) and found a correlation between increasing thermostability of enzymes with an increase in hydrophobic index of the proteins, an increase in the arginine to arginine plus lysine ratio, and a decrease in the ratio of polar to non-polar volumes.

By binding to the enzyme, starch (the substrate for amylases) may make the conformation of amylases more rigid and stable against denaturing conditions. However, starch does not stabilize amylases of *Thermoactinomyces* sp. No.15 (Obi and Odibo, 1984) or *Thermonospora curvata* (Glymph and Stutzenberger, 1977).

The presence of bovine serum albumin at high concentration stabilizes the enzymes of *B. acidocaldarius* (Buonocore *et al.*, 1976), *B. stearrowthermophilus* (Pfueller and Elliott, 1964) and *Thermonospora*

vulgaris (Allam *et al.*, 1975) but not that of *T. curvata* (Glymph and Stutzenberger, 1977). The increased concentration of protein is advantageous when proteases are present. Also, the addition of sugars and other polyols to aqueous enzyme solutions have a protective effect by reducing the amount of free water, strengthening hydrophobic interactions among non-polar amino acid residues, thereby making them more resistant to unfolding and thermal denaturation (Klibanov, 1983).

α -Amylases are much more resistant to temperature denaturation when calcium is present. The amount of calcium ions bound varies from one to ten (for a review see Vihinen and Mantsala, 1989). The enzymes of *B. subtilis*, *B. stearothermophilus*, and *B. amyloliquefaciens* (Hsiu *et al.*, 1964) contain four calcium ions. The last Ca^{2+} ion in *B. amyloliquefaciens* α -amylase has the greatest effect on stability and conformation (Hsiu *et al.*, 1964). Crystalline Taka-amylase A contains ten Ca^{2+} ions but only one is tightly bound. Calcium is bound outside the active center of the *B. amyloliquefaciens* enzyme (Hsiu *et al.*, 1964), to the SH group of a cysteine in the *B. subtilis* enzyme (Toda *et al.*, 1968), and to a carboxyl group in the *Thermophile* V2 α -amylase (Hasegawa and Imahori, 1976). The role of calcium may be in tightening different domains of the α -amylase. Calcium is suggested to bind to one of the conserved regions of α -amylases (Rogers, 1985) and may be stabilising the enzyme by tightening the binding between its different domains. Calcium may also counteract the destabilizing influence of negative charges in the molecule (Ward and Moo-Young, 1988).

Project aims

The major aim of this project was to clone and sequence an amylase gene from the thermophilic *Streptomyces* species *Streptomyces*

thermoviolaceus strain CUB74. The end-products of starch hydrolysis by the enzyme would be characterized to some extent by paper chromatography and the effects of some factors on the thermostability and activity of the enzyme would be determined. Induction and catabolite repression of the enzyme in the *Streptomyces* species would also be investigated.

CHAPTER TWO

MATERIALS AND METHODS

All chemicals, used in this thesis, were from BDH, Fisons, or Sigma. They were of AnalaR grade or of the highest grade available.

Ampicillin, tetracycline and chloramphenicol were from Sigma. Thiostrepton was a generous gift of S.J.Lucania, the Squibb Institute for Medical Research, New Jersey, USA.

Abbreviations:

v = Volume

d = Day

SDS = Sodium dodecyl sulphate

Na₂EDTA = Diaminoethanetetra-acetic acid disodium salt

IPTG = Isopropyl β-D-thiogalactoside

Xgal = 5-Bromo-4-chloro-3-indolyl-β-D-galactopyranoside

2.1 Bacterial strains and plasmids used in this thesis

The characteristics of *E. coli* strain JM107 and *S. lividans* strain TK24 are shown in Table 2.1. *S. thermoviolaceus* strain CUB74 was obtained from Dr A McCarthy (University of Liverpool).

All plasmids used in this thesis are shown in Table 2.1. Plasmids, pUC8, 18 and 19 were used for cloning in *E. coli* whereas pQR1 and pIJ903 were used for cloning in both *E. coli* and *Streptomyces* strains. pIJ702 was used for cloning in *S. lividans*.

2.2 Culture media and antibiotics

E. coli strains were grown overnight at 37°C in nutrient broth (Oxoid) or on nutrient agar (Oxoid nutrient broth solidified with 2% (w/v) Bacto agar) media. These media were supplemented with antibiotics, IPTG (40µg/ml) and Xgal (80µg/ml) when necessary. The final concentrations of antibiotics used are shown in Table 2.2.

CUB74 was grown overnight at 50°C in half-strength nutrient broth or half-strength nutrient agar. It was also grown on Mt/Yt agar (2.4% (w/v) Difco malt extract, 0.5% (w/v) Oxoid yeast extract, 2% (w/v) Bacto agar). TK24 was grown for 2-3d at 30°C in YEME (liquid) or on R2YE (solid) media (Hopwood *et al.*, 1985). TK24 was also grown on half-strength nutrient agar. These media were supplemented with thiostrepton when required. When studying induction and repression, the modified liquid minimal media (NMMP) of Hopwood *et al.* (1985) was used to grow *Streptomyces* strains. 1% (w/v) potato starch (Sigma, type S-4251) was added to solid media in order to visualise any amylase activity on plates.

2.3 Maintenance of bacterial species

E. coli strains were maintained on minimal media plates at 4°C after

Table 2.1 Bacterial strains and plasmids used in this thesis

Bacterial strains and plasmids	Genotype or relevant characteristics	Reference
<i>E. coli</i> JM107	<i>endA1 gyrA96 thi-1</i> <i>hsdR17 supE44 relA1</i> $\Delta(lac-proAB)$ (<i>F'</i> <i>traD36, proAB, lacI^q</i> Z Δ M15)	Yanisch-Perron <i>et al.</i> , 1985
<i>S. lividans</i> TK24 pUC8, pUC18, pUC19	Str-6, SLP2- SLP3- Ap ^r , <i>lacZα</i>	Hopwood <i>et al.</i> , 1983 Vieira and Messing, 1982.
pIJ702	Ts ^r Mel ⁺	Katz <i>et al.</i> , 1983
pQR1	pIJ702/pBR325 hybrid; Ts ^r Cm ^r Tc ^r	Barallon and Ward. Unpub.
pIJ903	Ap ^r Ts ^r	Lydiate <i>et al.</i> , 1985

Ap^r = Ampicillin resistance; Ts^r = thiostrepton resistance; Cm^r = chloramphenicol resistance; Tc^r = tetracycline resistance; Mel⁺ = melanin production via tyrosinase.

Table 2.2 Antibiotic concentrations ($\mu\text{g/ml}$) in the media used

Antibiotic	<i>Streptomyces</i>		<i>E. coli</i>	
	solid	liquid	solid	liquid
Ampicillin	-	-	500	50
Tetracycline	-	-	10	10
Chloramphenicol	-	-	25	25
Thiostrepton	50	5	-	-

growth at 37°C and nutrient agar slopes at room temperature or as cell suspensions in 20% (v/v) glycerol at -40°C. *Streptomyces* strains were maintained as spore suspensions in 20% (v/v) glycerol at -20°C.

2.4 Isolation of total DNA

Total DNA was prepared by a slightly modified method of that described by Chater *et al.* (1982). Mycelia, harvested from an overnight liquid culture of CUB74, were resuspended in 20ml of Birnboim buffer (25mM Tris/HCl pH7.5, 10mM EDTA, 0.9% (w/v) glucose, 2mg/ml lysozyme) and incubated at 30°C for 30min. After adding SDS to a final concentration of 1% (w/v), 4ml of 10mg/ml pronase (preself-digested at 37°C for 2h) was added. This was then mixed with 4ml TE buffer (10mM Tris/HCl pH7.5, 1mM EDTA, 20µg/ml RNase) and incubated at 37°C for 1h. 5ml of the same buffer was added and incubation was allowed for a further 2h at the same temperature. Finally, 1ml of 5M NaCl was added, 20ml of ethanol was layered on and the DNA was spooled with a flame-blunted Pasteur pipette. The DNA was resuspended in 18ml TE buffer and purified on a caesium chloride/ethidium bromide gradient if necessary.

2.5 Preparing competent *E. coli* cells and their transformation with plasmid DNA

An *E. coli* colony, taken from a minimal media plate, was used to inoculate 5ml nutrient broth overnight. 1ml was taken out and used to inoculate 200ml nutrient broth plus 20mM MgCl₂. This was grown for 2h and the cells were spun down, washed once with 100ml ice cold 75mM CaCl₂, 15% (v/v) glycerol and resuspended in 10ml of the same solution. This was finally divided into 500µl aliquots and kept frozen at -70°C.

During transformation, one aliquot (500 μ l) was mixed with plasmid DNA (up to 50 μ l) and left on ice for 45min. It was transferred to a 37°C water bath for 10min and finally poured into 5ml nutrient broth and grown for 2-3h at 37°C. 100 μ l of the transformation mixture was plated out on an appropriate selective plate.

2.6 Plasmid isolation from *E. coli*

Small scale preparation of plasmid DNA was performed as described by Birnboim and Doly (1979). 1.5ml was removed from a 5ml overnight culture of *E. coli* to a fresh 1.5ml Eppendorf tube and spun down at top speed for 5min in a microfuge. After resuspending the cells in 100 μ l Birnboim buffer, 200 μ l 0.2N NaOH, 1% (w/v) SDS was added and the mixture was vortexed. Then it was precipitated with 150 μ l of 4M sodium acetate pH6.0 on ice for 15min. It was spun at top speed for 10min and the supernatant was extracted with an equal volume of phenol/chloroform. After spinning for 5min, the top layer was removed and precipitated with 1/10v 5M NaCl and 2v ethanol at -20°C for 20min. The DNA was spun down, rinsed with 70% (v/v) ethanol and dried at 50°C. The dried pellet was finally resuspended in 500 μ l TE buffer plus RNase and kept at -20°C. 5-10 μ l was usually used for a single digest.

Large scale preparation of plasmid DNA from *E. coli* was performed as described by Birnboim and Doly (1979). 500ml overnight cultures were spun down at 8000rpm for 10min and resuspended in 20ml Birnboim buffer. After mixing with 40ml 0.2N NaOH, 1% (w/v) SDS, the preparation was precipitated on ice with 50ml 4M sodium acetate pH6.0 for 15min. It was then spun at 10000rpm for 30min and the supernatant was removed and mixed with 50ml 50% (w/v) polyethylene glycol (PEG) 6000 and left on ice for at least 1h. The preparation was spun down at

5000rpm for 15min and the pellet was resuspended in 5ml TE buffer plus RNase. After one phenol/chloroform extraction of the DNA suspension, the top layer was ethanol precipitated and resuspended in 5ml TE buffer. It was mixed with 5.5g CsCl and 300 μ l 10mg/ml ethidium bromide. This was spun at 5000rpm for 20h, relaxed to 4000rpm for 30min and the plasmid DNA band was removed with a syringe. The DNA solution was cleaned three times with a saturated solution of CsCl/isopropanol; each time an equal volume of CsCl/isopropanol solution was mixed with the DNA, left on bench for 3min and the top layer was removed to be cleaned again. Finally, the volume was made up to 5ml with TE buffer, precipitated with ethanol and rinsed with 70% (v/v) ethanol. The dried DNA pellet was resuspended in 1ml TE buffer and kept at -20°C.

2.7 Preparation of Streptomyces protoplasts and their transformation with plasmid DNA

Preparation of protoplasts from *Streptomyces* and their transformation were done essentially as described by Bibb *et al.* (1978) and Thompson *et al.* (1982). Mycelia harvested from a 200ml YEME culture were washed with 10.3% (w/v) sucrose and treated with protoplast buffer (10.3% (w/v) sucrose, 0.025% (w/v) K₂SO₄, 0.2% (w/v) MgCl₂, 0.005% (w/v) KH₂PO₄, 0.368% (w/v) CaCl₂, 0.573% (w/v) TES buffer pH7.2) containing 1mg/ml lysozyme. The mixture was filtered through cotton wool and sedimented gently. Protoplasts were resuspended in 5-10ml protoplast buffer and stored at -70°C in 500 μ l aliquots. During transformation with plasmid DNA, an aliquot was thawed, sedimented and the protoplast pellet was resuspended in the drop of buffer left in the tube. Concentrated plasmid DNA (in up to 20 μ l) was added and mixed

39

immediately with 0.5ml T buffer (protoplast buffer containing 25% (w/v) PEG 1000). 5ml protoplast buffer was added and after spinning the pellet was resuspended in 0.5ml protoplast buffer and plated on 5 R2YE plates. After 20h incubation at 30°C, soft agar containing the appropriate antibiotic was layered on four of the R2YE plates, 3ml on each. The fifth plate was kept as a control.

2.8 Plasmid isolation from *S. lividans*

Large scale preparation of plasmid DNA from *Streptomyces* was performed as described in the neutral lysis method (Bibb *et al.*, 1977). A 500ml 2d YEME culture was spun down at 10000rpm for 10min and the pellet was processed essentially as described by the neutral lysis method. After precipitation with PEG, the pellet was resuspended in 10ml TNE (30mM Tris/HCl, pH8.0, 5mM EDTA, 50mM NaCl), extracted once with phenol/chloroform and separated on a CsCl/ethidium bromide (EtBr) gradient.

The small scale preparation of plasmid DNA was based on the method described by Kieser (1984). A 50ml 2d YEME culture was spun down at top speed for 10min in a bench centrifuge and the pellet was resuspended in 5ml lysis buffer (25mM Tris/HCl pH8.0, 0.3M sucrose, 25mM EDTA, 50mM glucose). This was repelleted, resuspended in 5ml lysis buffer plus 2mg/ml lysozyme plus 50µg/ml RNase and incubated at 37°C with shaking for 1h. 3ml 0.3M NaOH, 2% (w/v) SDS (made fresh and preheated at 55°C) was added, vortexed for 2min and left at 55°C for 35min with occasional shaking. After leaving it on the bench to cool for 10-15min, 3ml phenol/chloroform was added and the mixture was vortexed and spun for 15min at top speed in a bench centrifuge. The top layer was recovered, added to 6-7ml isopropanol plus 1ml 3M

potassium acetate pH4.8 and left on bench for 5min (for plasmids larger than 20kb, this step was carried out on ice for 20-30min). After a 20min spin, the pellet was washed with 2ml ice-cold ethanol and then dissolved in 2ml TE. 4ml 0.2N NaOH, 1% (w/v) SDS was added, vortexed and left on ice for 5min. 3ml of 3M ice-cold potassium acetate was added, vortexed and left on ice for 15-20min with occasional shaking. After a 15min spin, the supernatant was mixed with 3ml phenol/chloroform and the top layer, after spinning, was removed and precipitated with isopropanol as above. The DNA pellet was resuspended in 500 μ l TE, extracted once with phenol/chloroform and reprecipitated with isopropanol as above. The pellet was finally washed twice with 75% (v/v) ethanol and once with ethanol, dried and resuspended in 50 μ l TE. 1 μ l was usually used for a single DNA digest. The DNA sample was stored at -20°C. To quantitate the DNA, its absorbance was measured. An OD₂₆₀ of 1 is equivalent to 50 μ g/ml double-stranded DNA.

2.9 Restriction enzyme digestions, ligations and agarose gels

All restriction endonuclease digestions and ligations were performed as described by Maniatis *et al.* (1982). 1 μ l (5 units) of restriction enzyme was usually mixed with 2 μ l 10x restriction buffer (500mM Tris/HCl pH7.5, 50mM MgCl₂ and NaCl; the concentration of NaCl varies with the restriction enzyme used) and DNA. The volume of the reaction mixture was made up to 20 μ l with TE buffer. After 2-3h incubation at 37°C, 5 μ l stop mix (0.1M EDTA, 40% (w/v) sucrose, 0.15 mg/ml bromophenol blue) was added and the sample was loaded onto an agarose gel and electrophoresed.

1% or 1.4% (w/v) agarose gels were used to separate DNA bands. They

were made in electrophoresis buffer (90mM Tris-Base, 90mM boric acid, 10mM EDTA, 0.5µg/ml EtBr) and electrophoresed in the same buffer at 150v for 2-3h. The DNA bands were visualised on a transilluminator and photographed.

Ligation reactions contained the DNA to be ligated (in a volume of 40-50µl), 2µl T4 ligase (20 units), and 1/10 volume 10x ligation cocktail (660mM Tris/HCl pH7.5, 100mM MgCl₂, 100mM dithiothreitol (DTT), 1mM ATP).

2.10 DNA extraction from agarose gels

Extraction of DNA bands from agarose gels was performed as described by Girvitz *et al.* (1980). Two cuts were made one under and the other above the DNA band of interest. A Whatman 3mm paper and a piece of single dialysis membrane were inserted in each cut and the agarose gel was electrophoresed at 300v for 10min. The bottom paper and dialysis tubing were removed from the gel and washed four times, 100µl each, with elution buffer (0.2M NaCl, 50mM Tris/HCl pH7.6, 1mM EDTA, 0.1% (w/v) SDS). The washes were collected and extracted once with phenol, once with phenol/chloroform and once with chloroform. The DNA was recovered by ethanol precipitation, rinsed with 70% (v/v) ethanol and dried. The DNA pellet was redissolved in a small volume of TE buffer.

2.11 Making radioactive probes

Radiolabelled DNA probes were made as essentially described in the instructions booklet from Amersham (Amersham International plc). The enzyme and nucleotide buffer solutions provided in the Amersham nick-translation kit (N 5000) were used. A nick-translation reaction (100µl) contained 2µg DNA, 5µg of unlabelled dATP, dGTP, and dTTP, 5 units DNA polymerase I, 100pg DNase I, and 100µCi (α -³²P)dCTP

(specific activity 3000Ci/mmole). The reaction was incubated at 16°C for 1-2h and then stopped by adding 2 μ l 0.5M EDTA. Finally, the nick-translated DNA was separated from the unincorporated dNTPs by centrifugation through a small column of Sephadex G-50 equilibrated in TE. The collected radioactive DNA was now ready to be used for probing a Southern or a Northern blot. An aliquot (1-2 μ l) was measured in a scintillation counter.

Probes used in high resolution S₁ mapping were labelled specifically at the 5' protruding end. The reaction mixture contained 1 μ g dephosphorylated DNA (Section 2.12), 10 μ l kinase buffer (0.5M Tris/HCl pH7.6, 0.1M MgCl₂, 50mM DTT, 1mM spermidine, 1mM EDTA), 150 μ Ci (γ -³²P)ATP (specific activity 3000Ci/mmole), 10-20 units T4 polynucleotide kinase, and H₂O to make the volume up to 50 μ l. This was incubated at 37°C for 30min. After adding 2 μ l 0.5M EDTA, the labelled DNA was separated from the unincorporated (γ -³²P)ATP by centrifugation through a G-50 Sephadex column prepared in a 1ml syringe. It was extracted once with phenol/chloroform and precipitated with ethanol. The DNA pellet was finally redissolved in sterile water.

2.12 Dephosphorylation of DNA

This was essentially done as described by Maniatis *et al.* (1982). The reaction mixture contained 1-5 μ g DNA, 5 μ l 10x CIP buffer (0.5M Tris/HCl pH9.0, 10mM MgCl₂, 1mM ZnCl₂, 10mM spermidine), 0.1 unit calf intestinal alkaline phosphatase (from P-L Biochemicals Inc.), and H₂O to make the volume up to 50 μ l. This was incubated at 37°C for 30min. A second aliquot of the alkaline phosphatase was added and it was incubated for a further 30min. 40 μ l H₂O, 10 μ l 10x STE (100mM Tris/HCl pH8.0, 1M NaCl, 10mM EDTA), and 5 μ l of 10% (w/v) SDS were added and

heated to 68°C for 15min. It was extracted once with phenol/chloroform, twice with chloroform and finally passed through a spun column of sephadex G-50. After ethanol precipitation, the DNA was ready for kinasing or ligation.

2.13 Southern blotting (Southern, 1975)

The DNA to be blotted was first analysed on an agarose gel and checked under ultraviolet (UV) light. The agarose gel was then soaked twice, 15min each, in 0.25M HCl and for 1h in several volumes of 1.5M NaCl, 0.5N NaOH at room temperature with constant shaking. The gel was then neutralized by soaking in several volumes of 1M Tris/HCl pH8.0, 1.5M NaCl for 1h with shaking. The agarose gel was placed upside down on a Whatman 3mm paper whose sides were immersed in 10x SSC (20x SSC is made by mixing 175.3g NaCl, 88.2g sodium citrate and H₂O up to 1l after adjusting the pH to 7.0 with NaOH). A piece of nitrocellulose filter (from Schleicher and Schull BA85), soaked in 2x SSC, was placed on top of the gel. Two pieces of Whatman 3mm paper, wetted with 2x SSC, were placed on top of the nitrocellulose filter. A stack of paper towels (5-8cm) was placed on top of the 3mm paper. Finally, a glass plate and a weight were placed on top of the paper towels. After 18h, the nitrocellulose filter was removed, soaked in 6x SSC for 5min and dried between two sheets of 3MM paper at 80°C under vacuum.

In order to hybridize the nitrocellulose filter, it was soaked in 6x SSC for 2min and placed in a heat-sealable plastic bag. A prehybridization solution (6x SSC, 0.5% (w/v) SDS, 5x Denhardt's solution, 10µg/ml denatured salmon sperm DNA), warmed up to 68°C, was added (0.2ml/cm² nitrocellulose filter). 50x Denhardt's solution is 5g polyvinylpyrrolidone, 5g bovine serum albumin (BSA) plus H₂O to 500ml.

Air was squeezed out and the plastic bag was sealed. It was incubated for 3h at 68°C with shaking. The prehybridization solution was then squeezed out, and a hybridization solution (50µl/cm² filter) (prehybridization solution plus 0.01M EDTA) and 50µl ³²P-labelled denatured DNA probe were added to the filter, air was squeezed out and the bag was sealed. The bag was incubated at 68°C overnight with shaking. The filter was washed with gentle agitation at room temperature, once with 2x SSC, 0.5% (w/v) SDS for 5min and once with 2x SSC, 0.1% (w/v) SDS for 15min. The filter was incubated in 0.1x SSC, 0.5% (w/v) SDS for 2-4h at 68°C with gentle agitation. The filter was finally exposed to an X-ray film overnight.

2.14 Isolation of total mRNA from *Streptomyces*

Streptomyces cultures grown in TSB (tryptone soya broth) or NMMP liquid media were filtered onto crushed ice and washed with 15ml chilled sterile water. The mycelia were resuspended in 5ml modified Kirby mixture (Hopwood *et al.*, 1985) (1% (w/v) sodium-triisopropyl-naphthalene sulphonate, 6% (w/v) sodium 4-amino salicylate, 6% (w/v) phenol mixture, 50mM Tris/HCl pH8.3) and vortexed vigorously for 2min. The homogenate was layered on a 5.7M CsCl, 0.1M EDTA cushion in an ultracentrifuge tube. It was spun at 35000rpm for 12h at 25°C. DNA was removed from the interface and the tube was inverted. The bottom of the tube was cut off and the RNA pellet was resuspend^{ed} in sterile water. An OD₂₆₀ of 1 is equivalent to 40µg^{/ml} RNA.

2.15 Northern blotting (Fourney *et al.*, 1988)

Each RNA sample (in a volume of 5µl) was mixed with 25µl loading dye (75% (v/v) formamide, 24% (v/v) 37% formaldehyde, 0.8% (w/v) bromophenol blue, 10% (v/v) glycerol, 6.6% (v/v) 10x MOPS buffer (0.2M

MOPS, 50mM sodium acetate, 10mM EDTA, pH7.0) and incubated at 65°C for 15min. 1µl 10% EtBr was added and the sample was loaded onto an agarose gel (made in a solution containing 5.1ml 37% formaldehyde, 10ml 10x MOPS buffer pH7.0, and 87ml sterile water). It was electrophoresed at 14v/cm for 2h in 1x MOPS buffer alongside suitable RNA standards. The RNA bands were visualized on a transilluminator and photographed. The RNA was then blotted onto a Zeta-probe nylon membrane (from Biorad) in 20x SSC. The membrane was dried as in Southern blotting. It was first treated with a prehybridization solution (50% (v/v) formamide, 4x SSC, 1% (w/v) SDS, 5x Denhardt's solution, 500µg/ml denatured salmon sperm DNA) for 30min at 50°C and then the denatured ³²P-nick-translated DNA probe was added and hybridization was carried out in the same solution overnight at 50°C. The membrane was rinsed in 2x SSC for 15min at room temperature, then in the following solutions for 15min each and at 50°C, 2x SSC plus 0.1% (w/v) SDS, 0.5x SSC plus 0.1% (w/v) SDS, and 0.1x SSC plus 0.1% (w/v) SDS. The final wash was repeated until the radioactivity background was undetectable. The filter was finally exposed to an X-ray film (Fuji RX).

2.16 High resolution S₁ mapping (Berk and Sharp, 1977)

An RNA sample and the test DNA were co-precipitated with isopropanol at -20°C. The test DNA was labelled specifically at the 5' position using T₄ DNA polynucleotide kinase (see Section 2.11). The pellet was rinsed with 80% (v/v) ethanol and dried. It was resuspended in 20µl hybridisation solution (40mM PIPES pH6.4, 400mM NaCl, 1mM EDTA, 80% (v/v) formamide) and placed in an 85°C water bath for 10min. The setting for the water bath was turned down allowing the temperature to

equilibrate slowly to 62-63°C over a period of 30-60min. It was incubated at this temperature for 3-4h. It was mixed with 300µl chilled S₁ digestion solution (1000 units S₁ nuclease, 0.28M NaCl, 30mM sodium acetate pH4.4, 4.5mM zinc acetate, 20µg/ml partially cleaved denatured non-homologous DNA) and incubated at 37°C for 45min. The reaction was stopped by adding 75µl S₁ termination solution (2.5M ammonium acetate, 0.05M EDTA) and mixed. 10µg carrier tRNA was added and the mixture was precipitated with 400µl isopropanol at room temperature for 5min. It was spun for 5min and the pellet was washed with 80% (v/v) ethanol and dried. The pellet was resuspended in 5µl denaturing dye solution (80% (v/v) formamide, 10mM NaOH, 1mM EDTA, 0.1% (w/v) xylene cyanol, 0.1% (w/v) bromophenol blue), boiled for 3min at 90°C and quick-chilled on ice. The S₁-protected fragments were electrophoresed on a polyacrylamide-urea sequencing gel, alongside sequencing ladders of the test DNA (obtained from double-stranded DNA sequencing of a plasmid construct that contains the test DNA). The gel was then dried under vacuum and exposed to an X-ray film.

2.17 Sequencing

The dideoxy chain termination method of Sanger *et al.* (1977,1980) was used to sequence the amylase gene.

2.17.1 Cloning in M13 prior to sequencing

*Bam*HI, *Acc*I or *Sma*I sites of double-stranded M13mp18 or mp19 DNA were used for cloning of DNA fragments cut with the appropriate enzyme (*Sau*3A, *Taq*I or *Alu*I). The ligation mixtures were introduced into competent *E. coli* cells (see Section 2.5). After the heat shock of the transformation, the transformed cells were mixed with 10ml molten half-strength nutrient agar which contained X-gal (400µg/ml) and IPTG

(200 μ g/ml) and poured onto three agar plates. The plates were incubated at 37°C overnight. The clear plaques were picked and streaked on a lawn of JM107 in soft agar containing Xgal and IPTG as above. After overnight growth, the plates were stored at 4°C.

2.17.2 Preparation of viral DNA

A clear plaque was used to inoculate a 5ml nutrient broth containing 0.1ml of rapidly growing JM107 and the culture was incubated overnight with shaking at 37°C. 1.5ml of culture was spun in a microfuge for 5min and 1.4ml of supernatant was transferred to a fresh microfuge tube and spun again. 1.3ml of supernatant was transferred to a fresh microfuge tube and mixed with 200 μ l 25% (w/v) polyethylene glycol 6000 (PEG) containing 2.5M NaCl. It was left on ice for 15min, spun for 5min and the pellet was drained and resuspended in 100 μ l TE buffer. 50 μ l of phenol was added, vortexed for 30sec, allowed to stand for 2min, vortexed again and left for 2min. After a 5min spin, the top layer was recovered and precipitated with 10 μ l 4M sodium acetate pH6.0 and 300 μ l ethanol. Finally, the pellet was washed with ethanol, dried and resuspended in 20 μ l TE buffer. 1 μ l of this single-stranded DNA or template was checked on an agarose gel and the rest was stored at -20°C.

Double-stranded viral DNA templates were prepared by processing the pellet instead of the supernatant. The pellet was lysed and precipitated to remove chromosomal DNA as described in Section 2.6 for making plasmid DNA from *E. coli*. The supernatant obtained from that precipitation step was spun again and the supernatant was transferred to a fresh tube. 100 μ g/ml RNase was added and the preparation was incubated at 37°C for 20min. It was extracted once with

phenol/chloroform and the top layer was mixed with 2.5v ethanol and incubated at -20°C for 20min. After spinning, the pellet was washed with prechilled 70% (v/v) ethanol and dried. It was dissolved in $16\mu\text{l}$ H_2O and mixed with $4\mu\text{l}$ 4M NaCl and $20\mu\text{l}$ 13% (w/v) PEG 6000. After 20min incubation on ice, it was centrifuged and the pellet was washed and dried as before. The DNA was finally resuspended in $20\mu\text{l}$ H_2O . $5\mu\text{l}$ of this DNA was used for a single sequencing reaction. Minipreparation of double-stranded plasmid DNA templates were also prepared in the same way.

2.17.3 Annealing of primer to DNA

The 17-base universal primer (Pharmacia no. 27-1534-01) and reverse primer (Pharmacia no. 27-1534-01) were used in the annealing reactions which were carried out as described in the Pharmacia instructions booklet.

The annealing mixture for single-stranded DNA sequencing contained $5\mu\text{l}$ template DNA ($1\mu\text{g}$), $2\mu\text{l}$ primer (5ng), $1.5\mu\text{l}$ sequencing buffer (100mM Tris/HCl pH7.5, 100mM MgCl_2 , 100mM dithiothreitol) and $1.5\mu\text{l}$ H_2O . The mixture was incubated at 60°C for 10min, placed at room temperature for at least 10min. If not performing the sequencing reaction in the same day, the annealed DNA can be stored at -20°C .

When double-stranded DNA templates (plasmid or viral) were to be sequenced, they were first denatured with NaOH ($5\mu\text{l}$ template, $3\mu\text{l}$ H_2O , $2\mu\text{l}$ 2M NaOH) for 10min at room temperature and then precipitated with $3\mu\text{l}$ 3M sodium acetate pH4.5, $7\mu\text{l}$ H_2O and $60\mu\text{l}$ ethanol at -20°C for 20min. The precipitated DNA was washed with ice-cold 70% (v/v) ethanol, dried and resuspended in $6.5\mu\text{l}$ H_2O . $1.5\mu\text{l}$ sequencing buffer and $2\mu\text{l}$ primer were added and incubated at 37°C for 20min to anneal.

It was placed at room temperature for at least 10min. If not performing the sequencing reaction in the same day, the annealed DNA can be stored at -20°C .

2.17.4 Sequencing reaction

The annealed primer/template solution (see Section 2.17.3) was mixed with $3\mu\text{l}$ Klenow fragment of DNA polymerase I (6 units) and $2\mu\text{l}$ (α - ^{35}S)dATP ($20\mu\text{Ci}$) (from Dupont, NEG-009A). $3\mu\text{l}$ aliquots from this solution were placed on the walls of four microcentrifuge tubes labelled A, T, C, G. These tubes already contained $3\mu\text{l}$ A "mix" in tube A, $3\mu\text{l}$ T "mix" in tube T, etc. The premixed sequencing solutions of the Pharmacia kit were used. The solutions were not mixed until after the dispensing was completed. The tubes were microfuged for 2sec to initiate the sequencing reaction and incubated for 15min at room temperature. $1\mu\text{l}$ of a chase solution from the Pharmacia kit (dATP, dTTP, dCTP and dGTP at 2mM in solution) was placed on the wall of each tube and microfuged for 2sec. The tubes were incubated for a further 15min and $3\mu\text{l}$ stop solution (10mM EDTA, 0.3% (w/v) xylene cyanol and 0.3% (w/v) bromophenol blue made in formamide) was placed on the wall of each tube. They were microfuged and $3\mu\text{l}$ were removed and incubated at 90°C for 3min followed by quick chilling on ice, and then loaded onto a polyacrylamide-urea sequencing gel (63g urea, 11.4g polyacrylamide, 0.6g bis-acrylamide, 15ml 10x Tris borate buffer made up to 150ml with H_2O). The gel was electrophoresed in 1x Tris-borate electrophoresis buffer. The gel was finally dried and exposed to an X-ray film (Fuji RX).

2.18 Protein precipitation with ammonium sulphate

Extracellular enzymes were prepared from *E. coli* and *Streptomyces*

cultures by precipitating their supernatants with ammonium sulphate (90% (w/v) saturation). The salt was dissolved slowly with stirring on ice and the preparation was left on ice for at least 1h. The mixture was then spun down at 9000rpm for 10min and the precipitate was resuspended in a minimal volume of 20mM Tris/HCl pH7.5, 5mM CaCl₂ buffer. It was dialysed (in preboiled dialysis tubing.) twice against the same buffer at room temperature, 1h each, and once against the same buffer containing 50% (v/v) glycerol overnight at 4°C and finally stored at -20°C.

The Bio-Rad protein assay (Bio-Rad, Dye Reagent Concentrate, West Germany) was used to determine the protein concentration as described by the supplier. The concentrated dye was diluted with water (1:5, v/v) and 5ml of the diluted solution was mixed with 100µl of an appropriately diluted protein sample. After a period of 5min-1h, an OD₅₉₅ was read against a blank containing water plus diluted dye. BSA (20µg-150µg) was used to construct a standard curve. This original procedure was sometimes scaled down to 1ml.

2.19 SDS-PAGE

A protein sample (50-100µl) was denatured by mixing with an equal volume of loading dye solution (5% (v/v) mercaptoethanol, 3.4% (w/v) SDS, 15% (v/v) glycerol, 0.01% (w/v) bromophenol blue, 47mM Tris/HCl pH6.8) and boiling for 3min. It was loaded onto a 10 or 12% SDS-polyacrylamide gel (made as described by Laemmli, 1970), adjacent to molecular weight protein markers (from Sigma), and electrophoresed at 35mA for 3-4h or overnight at 7mA in the electrophoresis buffer pH8.4 (9.1g Tris base, 43.2g glycine, 3g SDS made up to 3l with H₂O). Protein bands were visualised on the gel after staining with Coomassie

Brilliant Blue solution (1.25g/l Coomassie Brilliant Blue R, 4.6% (v/v) acetic acid, 25% (v/v) methanol) for 1-2h and destaining with 7.5% (v/v) acetic acid, 5% (v/v) methanol.

2.20 Enzyme reactivation in the SDS-PAGE system

Proteins were renatured in the SDS-PAGE by washing the gel twice with 2.5% (v/v) Triton X100, 1h each, and then rinsing it with Tris/HCl pH7.5, 5mM CaCl₂ for 20min. The reactivated gel was sandwiched against a 1% (w/v) agarose gel made in the Tris/HCl, CaCl₂ buffer and contained 0.5% (w/v) potato starch. The sandwich was incubated between 2 glass plates and under a weight at 37°C overnight. Starch hydrolysis zones were detected by soaking the starch gel in 0.05% (w/v) I₂, 2.65% (w/v) KI.

2.21 Paper chromatography

This was done as described by Robyt and French (1963). 450µl 1% soluble starch (made in 20mM Tris/HCl buffer pH 7.5, 5mM CaCl₂) was mixed with 50µl of an enzyme sample to obtain a final concentration of 0.1unit/mg substrate. This was incubated at 50°C and 30 µl aliquots were removed from the digestion mixture at the time required (0, 0.5, 1, 2, 4, 8, 24h) and stored at -20°C in order to be applied later on the filter paper. When all aliquots of the time course were collected, 20µl of each aliquot was spotted onto a 3mm Whatman paper. A standard containing 1% (w/v) glucose, 1% (w/v) maltose, 1% (w/v) maltotriose (made in 20% (v/v) isopropanol) was also spotted onto the same filter. The solution used in the ascendant chromatography was isopropanol/water (4/1, v/v). After 5h, the paper was dried at 50°C and stained in a solution containing silver nitrate/acetone (1.5ml saturated AgNO₃/1408ml acetone). It was dried and dipped into a

solution containing 4ml 40% NaOH/400ml methanol and dried. It was then dipped into Kodak F-24 film fixer and immediately washed in water. Washing in water continued for at least 30min, after which the filter was dried and kept in the dark.

2.22 Cell fractionation

This was carried out as described by Minton *et al* (1983). A 40ml *E. coli* culture grown in the low phosphate medium of Neu and Heppel (1964) to an OD_{450} of 1 was pelleted at 4°C and the supernatant fraction was kept. The cell pellet was washed in 5ml ice-cold 10mM Tris/HCl pH7.0 and spun down at 4°C. This step was repeated and the cells were resuspended in 0.9ml 0.58M sucrose, 0.2mM DTT, 30mM Tris/HCl pH8.0. 5µl lysozyme (2mg/ml) was added to spheroplast the cells and after 2min 40µl 0.1M EDTA was added and the mixture was incubated at 30°C for 10min with gentle rotation. The preparation was placed on ice and 5ml of the sucrose buffer was added. $MgSO_4$ was added to a final concentration of 0.01M and the preparation was spun down at 6500rpm for 20min. The supernatant was kept as the periplasmic fraction whereas the pellet was resuspended in 5ml 10mM Tris/HCl pH7.0, 0.2mM DTT and sonicated at 20kc/sec for 15sec and vortexed vigorously. The remaining whole cells were removed by centrifugation at 3000rpm for 10min. The supernatant was respun at 39000rpm for 1h at 4°C. The supernatant of the last spin was kept as the cytoplasmic fraction and the pellet was resuspended in 1ml 10mM Tris/HCl pH7.0, 0.2mM DTT and kept as the membrane fraction.

2.23 Alkaline phosphatase assay

This was carried out as described by Torriani (1966). 0.9ml p-nitrophenyl phosphate (NPP) (1mg/ml made in 0.1M Tris/HCl pH8.0) was

prewarmed to 30°C and 0.1ml enzyme fraction (from the cell fractionation experiment) was added and the reaction was followed for 2-3min at OD₄₁₀. One unit of enzyme was defined as the amount producing 1µmol nitrophenol (NP)/min. The extinction coefficient of NP is $1.62 \times 10^4 \text{ M}^{-1} \text{ cm}^{-1}$.

2.24 α -Amylase assays

2.24.1 Somogyi assay

This assay was carried out as described by Nelson (1944). 500µl of a suitably diluted enzyme sample was mixed with 500µl of 1% soluble starch solution (made in 20mM Tris/HCl pH7.5, 5mM CaCl₂) and incubated at 50°C for 1h. 100µl of this mixture was removed and mixed with 900µl H₂O and 1ml of reagent 4 (made by mixing 1ml reagent 2 (3.75% (w/v) CuSO₄ mixed with a drop of H₂SO₄) with 25ml reagent 1 (2.5% (w/v) Na₂CO₃, 2.5% (w/v) KNaTartrate, 2% (w/v) NaHCO₃, 20% (w/v) Na₂SO₄) was added. It was boiled for 20min, cooled and 1ml reagent 3 (5% (w/v) ammonium molybdate, 4.2% (v/v) H₂SO₄, 0.6% (w/v) sodium arsenate heptahydrate) was added; reagent 3 was incubated for 16h at 37°C prior to use. The mixture was shaken until gas had evolved, left for 10min and 10ml H₂O was added and mixed. An OD₅₀₀ was taken against a blank prepared in the same way but the enzyme solution was replaced by the buffer. A standard curve using maltose as the reducing sugar was prepared. One unit of enzyme was defined as the amount which releases 1mg reducing sugar from starch in 1h at 50°C and pH7.5.

2.24.2 Turbidity assay

This assay was mainly used in the induction study. It was carried out as described by Long *et al* (1987) where 0.1ml of enzyme solution was mixed with 0.9ml of 1% potato starch solution prepared as described by

Virolle and Bibb (1988) (made in 50mM Na acetate buffer pH5.8) and the OD_{300} reading was followed for 1min. One unit is the amount of enzyme causing a decrease of OD_{300} of 0.1/min.

2.24.3 Plate assay

In addition to the above two methods, a plate assay was sometimes used to quantitate amylase activity. 100 μ l of test enzyme sample was placed in a well made in an agar plate that had been supplemented with 1% (w/v) potato starch, alongside 5-6 other wells each containing 100 μ l of different known amylase concentrations (already determined by the Somogyi method). The plate was incubated at 37°C for 7-8h and the diameter of each starch hydrolysis zone was measured. The zones produced by the known amylase concentrations were plotted against the natural logarithm (Ln) of amylase activity to construct a standard curve. Amylase activity in the test sample was calculated from the graph.

2.25 Total cell protein (Herbert et al., 1971)

This assay was used in the induction study of amylase in *Streptomyces*. Mycelia collected from 1ml samples were washed with H_2O , resuspended in 1ml H_2O and sonicated for 30sec. 750 μ l was removed from the sonicate, mixed with 375 μ l 3N NaOH and boiled for 30min. 375 μ l 2.5% (w/v) $CuSO_4$ was added and the mixture was spun for 5min. 1ml of supernatant was removed and OD_{555} was measured against a blank in which the sonicate was substituted with 750 μ l water. Different concentrations of bovine serum albumin (0.2, 0.4, 0.6, 0.8, 1, 2, 4, 6, 8, 10mg/ml) were used to establish a standard curve.

CHAPTER THREE CLONING AND EXPRESSION OF A THERMOSTABLE α -AMYLASE GENE
FROM *STREPTOMYCES THERMOVIOLACEUS* STRAIN CUB74 IN
ESCHERICHIA COLI JM107

The aim of the experiments described in this chapter was to clone an α -amylase gene from the thermophilic *Streptomyces* species *Streptomyces thermoviolaceus* strain CUB74. I chose to clone the CUB74 total DNA library in *E. coli* and to screen for colonies that produced amylase by detecting starch hydrolysis zones on starch plates. Once the cloned CUB74 α -amylase gene was found in *E. coli*, the second step would involve cloning and expression in *Streptomyces lividans*.

3.1 Making a CUB74 total DNA library in pUC8 and cloning into *E. coli*

Total DNA was isolated from *S. thermoviolaceus* strain CUB74 as described in Materials and Methods (Section 2.4). 5 μ g of this DNA was digested to completion with *Bam*HI in a total volume of 130 μ l. A ladder of faint bands of different sizes was seen when this digestion was electrophoresed in a 1% (w/v) agarose gel, indicating a complete digestion of the CUB74 chromosomal DNA with *Bam*HI (Fig.3.1). 2 μ g of pUC8 was also digested with *Bam*HI and a single 2.67kb band was observed on the agarose gel (Fig.3.1a). The two *Bam*HI digestions were extracted with phenol/chloroform, ethanol precipitated and ligated as described in Section 2.9. The results of this ligation is shown in Fig.3.1b. The ligation experiment seemed to have worked as the pattern of DNA bands observed in the ligation lane was different from that of the control. The ligated DNA was used to transform competent *E. coli*

Fig.3.1. Construction of CUB74 DNA library in pUC8.

a) *Bam*HI digestion of pUC8 and total chromosomal DNA isolated from *S. thermoviolaceus* CUB74. 1: λ -*Hind*III markers (kb); 2: undigested pUC8 DNA (control); 3: pUC8 DNA digested with *Bam*HI; 4: undigested CUB74 DNA (control); 5: CUB74 DNA digested with *Bam*HI.

b) Ligation of CUB74 and pUC8 DNA. 1: ligation; 2: unligated DNA (control).

a)

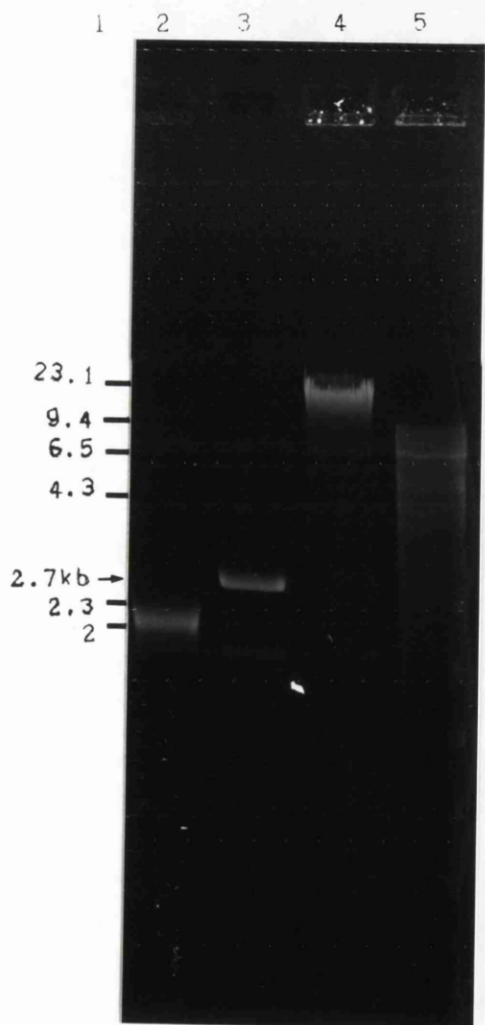

b)

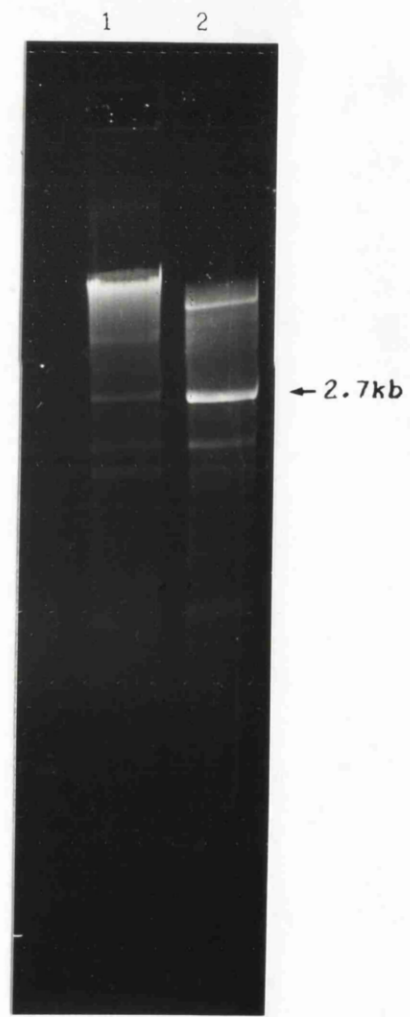

JM107 (see Section 2.5) and the transformation mixture was plated on ampicillin, Xgal, IPTG nutrient agar plates.

A total of approximately 10000 colonies were obtained, 6400 (64%) of which were recombinants (white) and the remaining (3600, 36%) were blue. All *E. coli* plates were replica-plated, using sterile pads, onto two sets of plates, one supplemented with 1% (w/v) potato starch to screen for amylase production and the other with 1% (w/v) skimmed milk to screen for protease production. On starch plates, a white (recombinant) *E. coli* colony produced a large starch hydrolysis zone whereas on skimmed milk plates all colonies were protease negative. The amylase zone was observed without applying any iodine stain. The amylase positive recombinant *E. coli* was restreaked onto a fresh starch plate. Fig.3.2 shows the starch hydrolysis zones produced by the recombinant *E. coli* before and after staining with iodine in comparison with the control pUC8-containing *E. coli*.

A plasmid miniprep (see Section 2.6) from the recombinant amylase positive colony was digested with *Bam*HI to determine what insert it contained. The *Bam*HI digestion resulted in two bands, one corresponding to pUC8 (2.67kb) and another of 5.7kb in length (Fig.3.3a). The plasmid construct was called pQR300. A large scale plasmid preparation (see Section 2.6) from pQR300 was carried out and the purified plasmid pQR300 was reintroduced into competent *E. coli* JM107. 100% of colonies obtained from this transformation were amylase positive.

3.2 Results of Southern blotting

In order to confirm the origin of the 5.7kb insert found in plasmid pQR300, a complete *Bam*HI digestion of total *S. thermoviolaceus* CWB74

Fig.3.2. Comparison between amylase zones produced by *E. coli* pQR300 and *E. coli* pUC8 (control). *E. coli* cultures were grown overnight on nutrient agar plates that had been supplemented with potato starch and ampicillin. Before staining with iodine (1), amylase zones are visualized as cloudy zones around colonies, whereas after staining (2), amylase zones are visualized as clear zones.

1) Before staining with iodine.

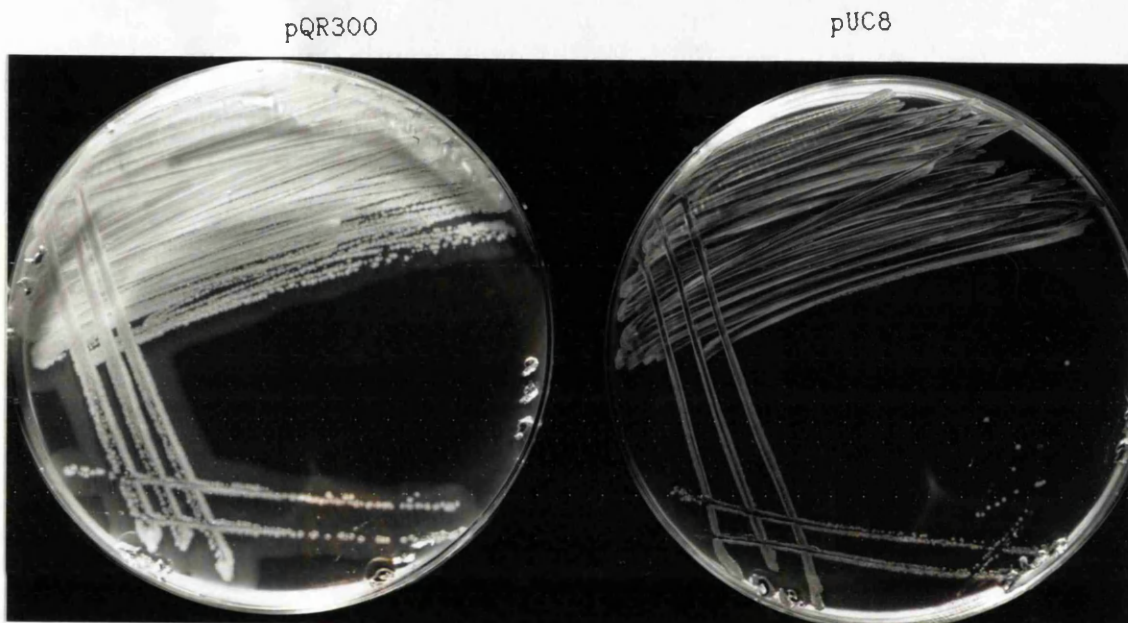

2) After staining with iodine.

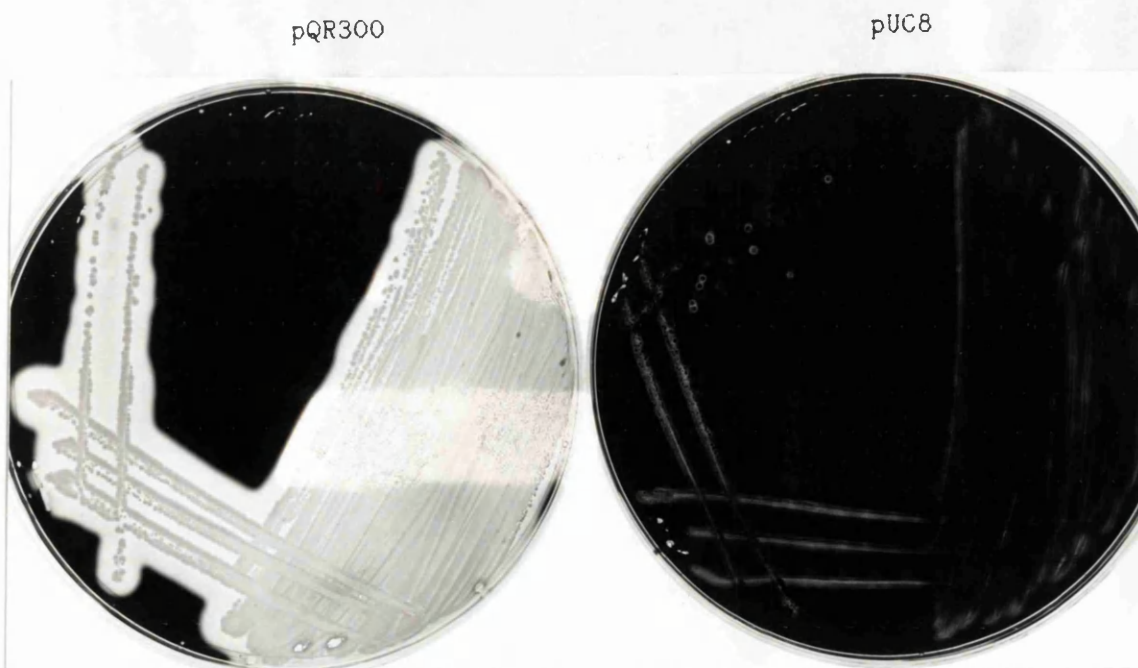
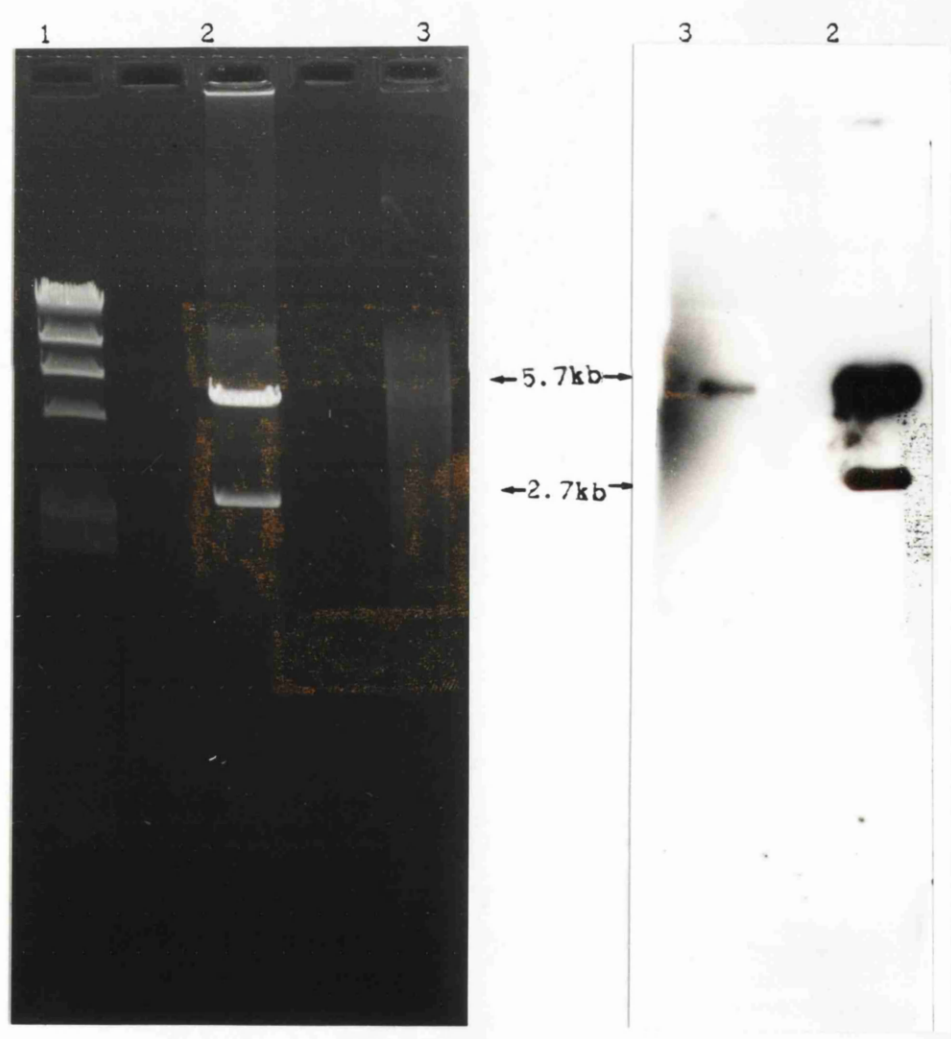

Fig.3.3. Southern blotting. DNA samples were first analysed on an agarose gel (a) and then blotted onto a nitrocellulose filter and probed with ³²P-labelled linear pQR300 (b) as described in Chapter Two. 1: λ HindIII; 2: plasmid pQR300 digested with *Bam*HI; 3: total CUB74 DNA digested with *Bam*HI.

a) Before blotting

b) After blotting and probing



chromosomal DNA was blotted as described in Section 2.13 alongside pQR300 digested with the same enzyme. The Southern nitrocellulose filter was hybridized to pQR300 that had been linearized with *Bam*HI and labelled with (α - 32 P)dCTP (see Section 2.11). The labelled probe hybridized to a single band of 5.7kb in the chromosomal DNA lane and to 2.7kb (linear pUC8) and 5.7kb (insert) bands in the pQR300 lane (Fig.3.3b). This experiment confirmed that the 5.7kb insert found in plasmid pQR300 had come from *S. thermoviolaceus* CUB74 chromosomal DNA.

3.3 Restriction enzyme map of the 5.7kb *Bam*HI insert

The following enzymes were used to determine the map of the 5.7kb *Bam*HI DNA fragment: *Bam*HI, *Eco*RI, *Pst*I, *Bgl*III, *Sph*I, *Not*I and *Sma*I. Single and double digestions with these enzymes were set up and analysed on agarose gels. Fig.3.4 shows some of the results of these digestions and Fig.3.5 shows the complete restriction enzyme map of the 5.7kb *Bam*HI-fragment. Restriction enzymes which had cut the 5.7kb DNA fragment at single sites were *Hind*III, *Pst*I, *Bgl*III and *Sph*I. The single *Hind*III, *Sph*I, *Bgl*III, and *Pst*I sites are located 150bp, 1700bp, 3100bp, and 3200bp respectively from the *Bam*HI site that is close to the *lacZ* promoter in pQR300 (Fig.3.5). *Sma*I and *Not*I restriction enzymes cut the 5.7kb fragment at several sites but only the sites located within the 1.7kb *Bam*HI/*Sph*I section were mapped.

3.4 Results of subcloning experiments in *E. coli*

In order to locate the amylase gene on the 5.7kb *Bam*HI DNA fragment, several subcloning experiments were carried out in *E. coli*, in which sections of the DNA fragment were removed. Plasmid pQR300 was digested with *Bam*HI and *Bgl*III and the digestion mixture was religated hoping that some of the resulting plasmid constructs would contain only a

Fig.3.4. Examples of single restriction enzyme digests of plasmid pQR300. 1: λ HindIII; 2: undigested pQR300 (control); 3: digestion with BamHI; 4: digestion with PstI; 5: digestion with BglII.

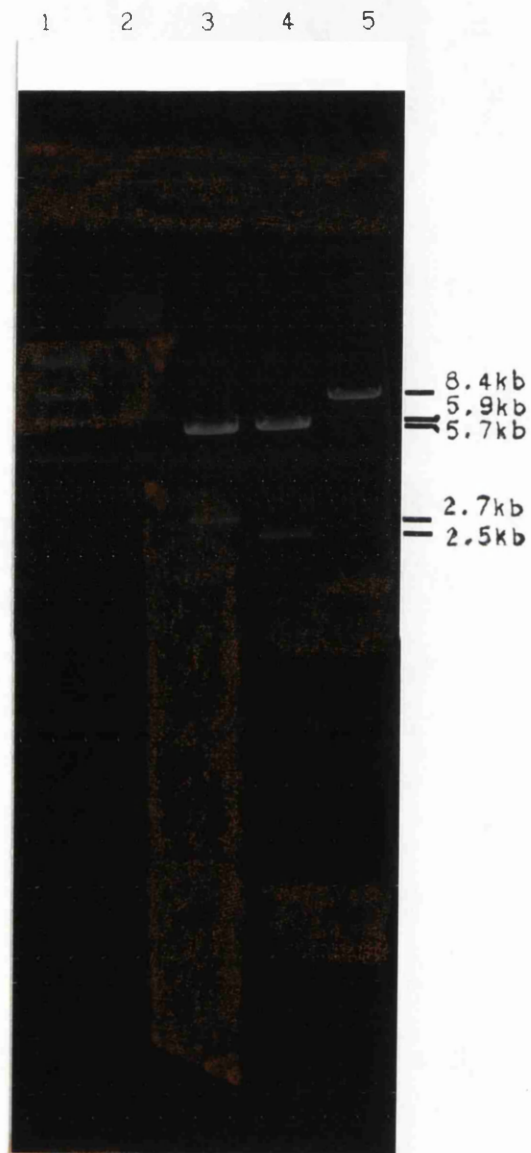

Fig.3.5. Restriction enzyme map of pQR300. The arrows represent the orientation of the amylase gene (*amy*), *lacZ* on pUC8, origin of replication (Ori), and ampicillin resistance region (*Ap^r*). B: *Bam*HI; H: *Hind*III; N: *Not*I; Sm: *Sma*I; S: *Sph*I; Bg: *Bgl*III; P: *Pst*I; E: *Eco*RI. The distances between the restriction enzyme sites are in bp. See Appendix 1 for a schematic diagram of pUC8.

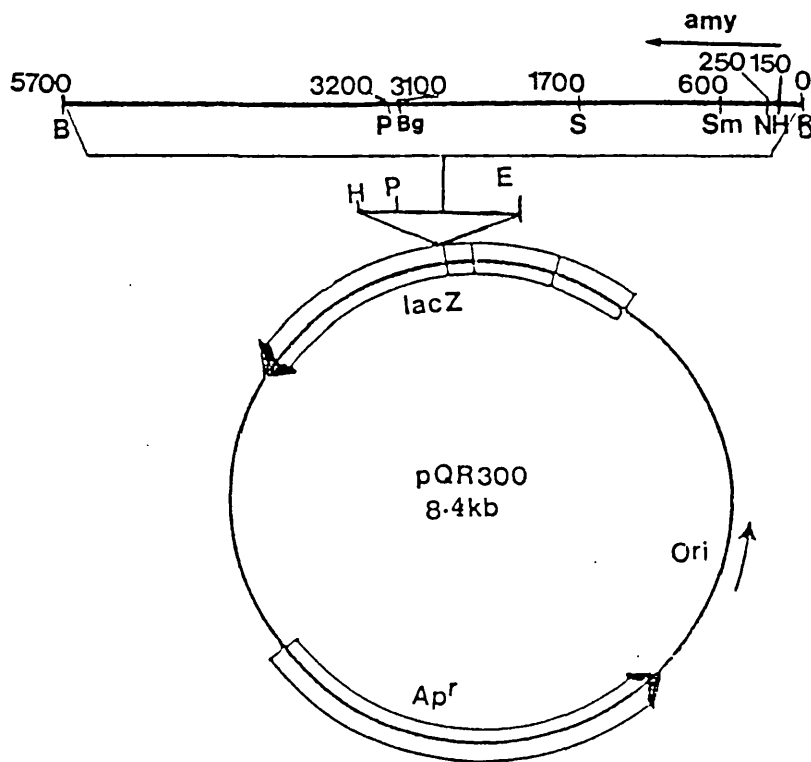
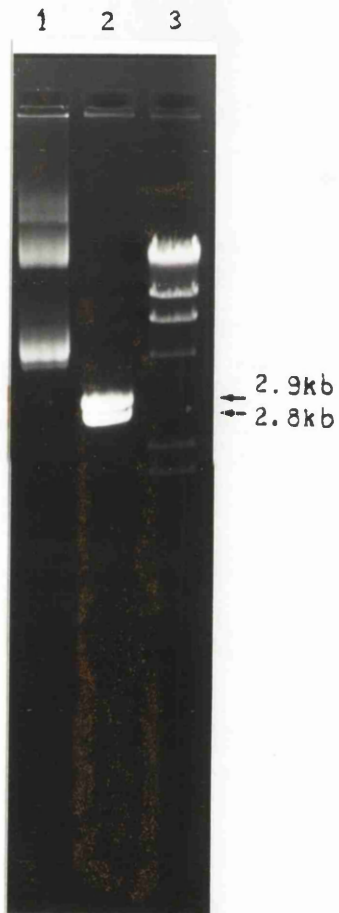
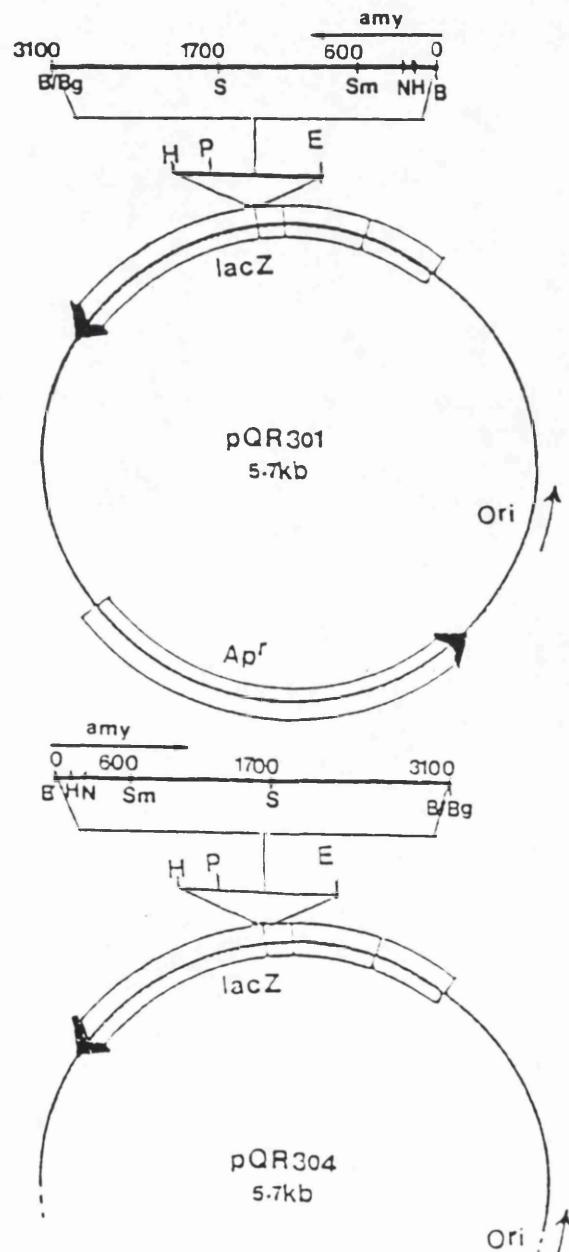

Fig.3.6. Construction of plasmids pQR301 and pQR304. pQR301 and pQR304 were constructed by removing a 2.6kb *Bam*II-*Bgl*III fragment from pQR300. a) Analysis of pQR301 on an agarose gel. 1: undigested pQR301 (control); 2: pQR301 digested with *Hind*III; 3: λ *Hind*III. b) Restriction enzyme maps of pQR301 and pQR304. All abbreviations are as described in the legend of Fig.3.5.

a)



b)



portion (3.1 or 2.6kb) of the 5.7kb *Bam*HI DNA fragment. A plasmid construct pQR301 (pUC8 plus the 3.1kb *Bam*HI/*Bgl*III portion) was found in the amylase positive colonies that had resulted from this experiment (Fig.3.6). This experiment proved that the amylase gene was carried by the 3.1kb *Bam*HI/*Bgl*III segment of the 5.7kb *Bam*HI DNA fragment. Another plasmid construct called pQR304 was found in the amylase negative colonies that had resulted from the same experiment. pQR304 is the same as pQR301 but with the 3.1kb insert in the opposite orientation with respect to the *lacZ* promoter on pUC8 (Fig.3.6).

To further locate the amylase gene on the 3.1kb *Bam*HI/*Bgl*III DNA fragment, pQR301 was digested to completion with *Bam*HI and *Sph*I. This digestion resulted in two bands, the smallest of which (1.7kb) was extracted from the agarose gel (see Section 2.10) and ligated to pUC18 that had been cut with *Bam*HI and *Sph*I. Upon transformation of *E. coli* with this ligation mixture, all transformants obtained were amylase positive. Plasmid minipreparation and digestion with *Bam*HI/*Sph*I revealed that these amylase positive colonies had a plasmid construct called pQR307 which is pUC18 plus the 1.7kb *Bam*HI/*Sph*I DNA fragment (Fig.3.7).

The subcloning experiments described so far had shown that the cloned α -amylase gene of CUB74 resided on a 1.7kb *Bam*HI/*Sph*I fragment and its transcription occurred in the direction from the *Bam*HI to *Sph*I^{sites}. After this finding, the 1.7kb *Bam*HI/*Sph*I fragment was digested further. Plasmid pQR307 was digested with *Hind*III and the 1.55kb segment located between the *Hind*III site of insert and the *Hind*III site of polylinker was extracted from the agarose gel and subcloned into pUC18 that had been also cut with *Hind*III. Plasmids were prepared from both

Fig.3.7. Construction of plasmid pQR307. pQR307 was constructed by cloning the amylase gene on a 1.7kb *Bam*HI-*Sph*I fragment into pUC18 cut with the same enzymes. a) Analysis of pQR307 DNA on an agarose gel. 1: λ *Hind*III; 2: undigested pQR307 (control); 3: pQR307 digested with *Hind*III. b) Restriction enzyme map of pQR307. The arrows represent the orientation of *amy* and different regions of pUC18. K: *Kpn*I; other abbreviations are as described in the legend of Fig.3.5. See Appendix 2 for a schematic diagram of pUC18.

a)

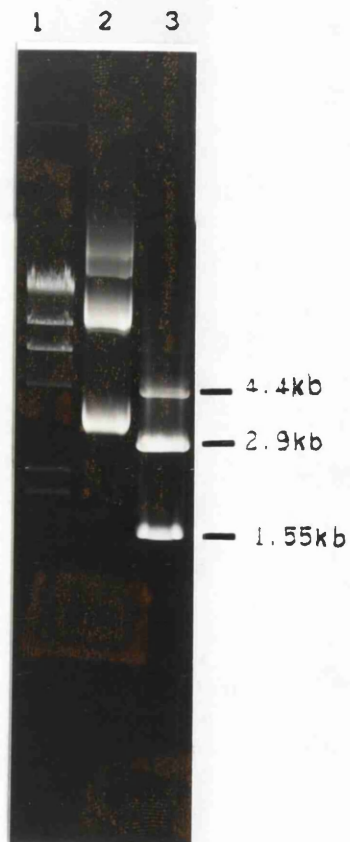

b)

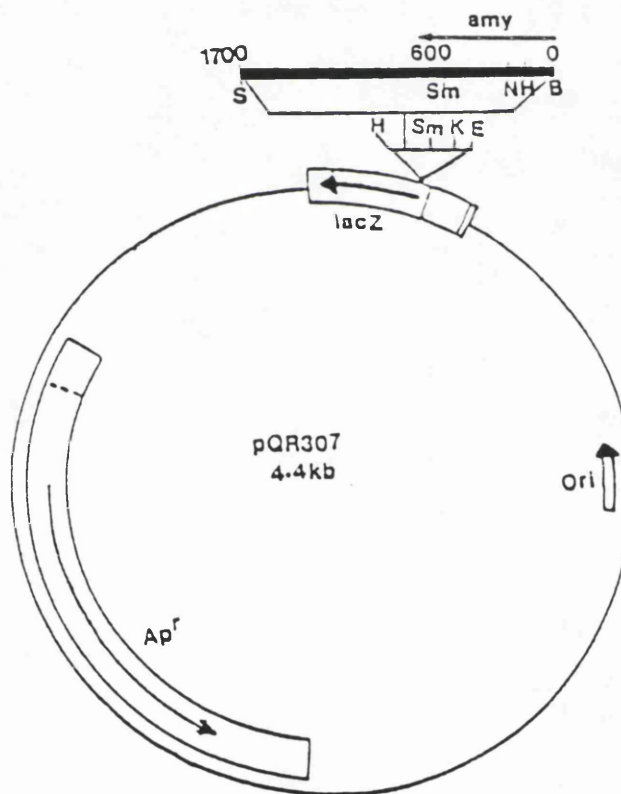
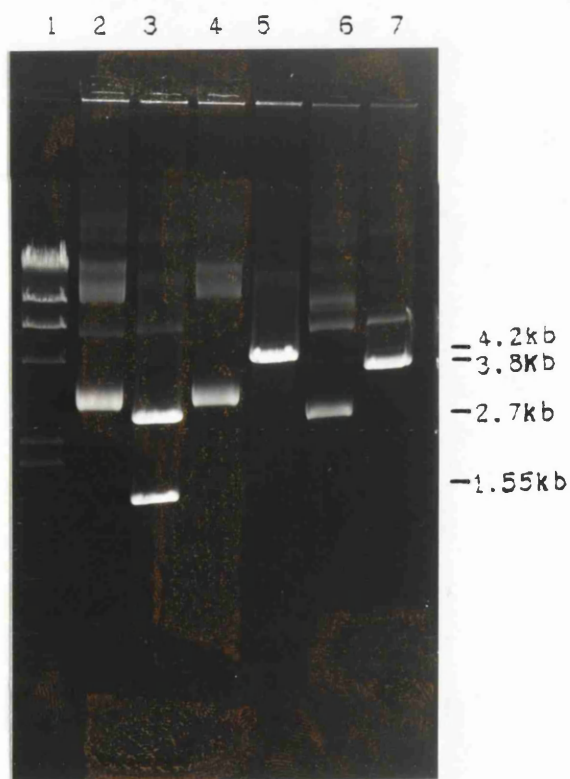
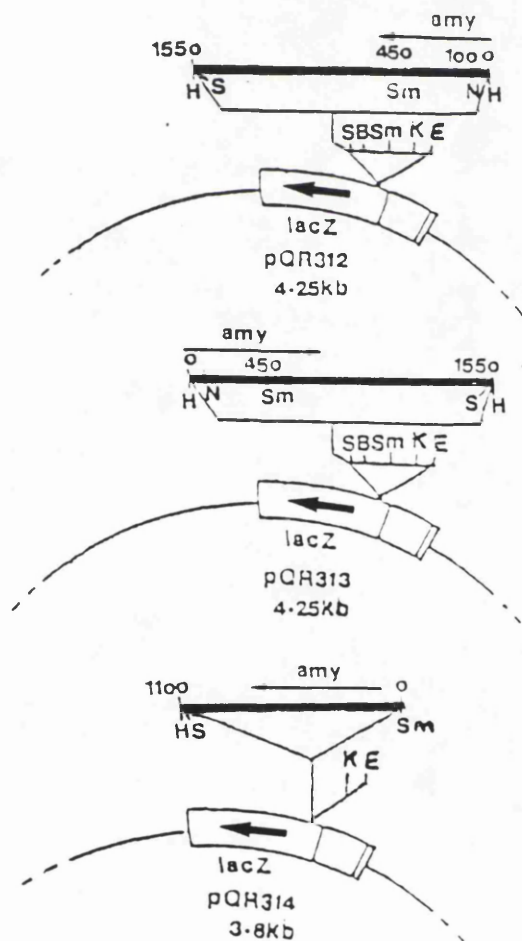

Fig.3.8. Construction of plasmids pQR312, pQR313, and pQR314. pQR312 and pQR313 were constructed by cloning a 1.55kb *Hind*III fragment carrying *amy* into the *Hind*III site of pUC18. pQR314 is constructed by removing a 0.45kb *Sma*I fragment from pQR312. a) Analysis of pQR312, 313, and 314 on an agarose gel. 1: λ *Hind*III; 2: undigested pQR312 (control); 3: pQR312 digested with *Sph*I; 4: undigested pQR313 (control); 5: pQR313 digested with *Sph*I; 6: undigested pQR314 (control); 7: pQR314 digested with *Sma*I. b) Restriction enzyme maps of pQR312, 313, and 314. Abbreviations are as described in the legend of Fig.3.5.

a)



b)



amylase positive and amylase negative transformant *E. coli* colonies obtained from transformation with the *Hind*III ligation. They were digested with *Sph*I to determine the orientation of the insert and analysed on an agarose gel. The amylase positive colonies resulted from this experiment were found to have a plasmid called pQR312 (pUC18 plus 1.55kb *Hind*III fragment) whereas the amylase negative colonies were found to have a plasmid called pQR313 which is the same as pQR312 but with the 1.55kb *Hind*III insert in the opposite orientation in relation to the *lacZ* promoter on pUC18 (Fig.3.8).

pQR312 was also cut with *Sma*I and the largest fragment (3.8kb) located between the *Sma*I site of the insert and the *Sma*I site of the polylinker was extracted from an agarose gel and religated. The resulting plasmid construct pQR314 (pUC18, plus 1.1kb *Sma*I/*Sph*I fragment) (Fig.3.8) did not code for any amylase production indicating that the *Sma*I site lies within the structural gene of the CUB74 α -amylase.

3.5 Expression of the cloned CUB74 α -amylase in *E. coli*

In order to determine whether the cloned CUB74 α -amylase gene was being expressed in *E. coli* from its own promoter or from the *lacZ* promoter on pUC8, the whole 5.7kb *Bam*HI insert was subcloned in the opposite orientation in comparison with the *lacZ* promoter by digesting pQR300 with *Bam*HI and religating the whole mixture. This resulted in amylase positive and amylase negative colonies. A plasmid pQR303 (Fig.3.9) was found in the amylase negative colonies. This plasmid construct is the same as pQR300 but the 5.7kb *Bam*HI insert is in the opposite orientation with comparison to the *lacZ* promoter on pUC8. The orientation of the insert was determined by carrying out a *Hind*III

Fig.3.9. Construction of plasmid pQR303. This construct is similar to pQR300 (Fig.3.5) but only differs by the orientation of the amylase gene. It was constructed by cutting pQR300 with *Bam*HI and religating the whole mixture. a) Analysis of pQR303 DNA on an agarose gel. 1: λ HindIII; 2: undigested pQR303; 3: pQR303 digested with *Bam*HI; 4: pQR303 digested with *Hind*III. b) Restriction enzyme map of plasmid pQR303. Abbreviations are as described in the legend of Fig.3.5.

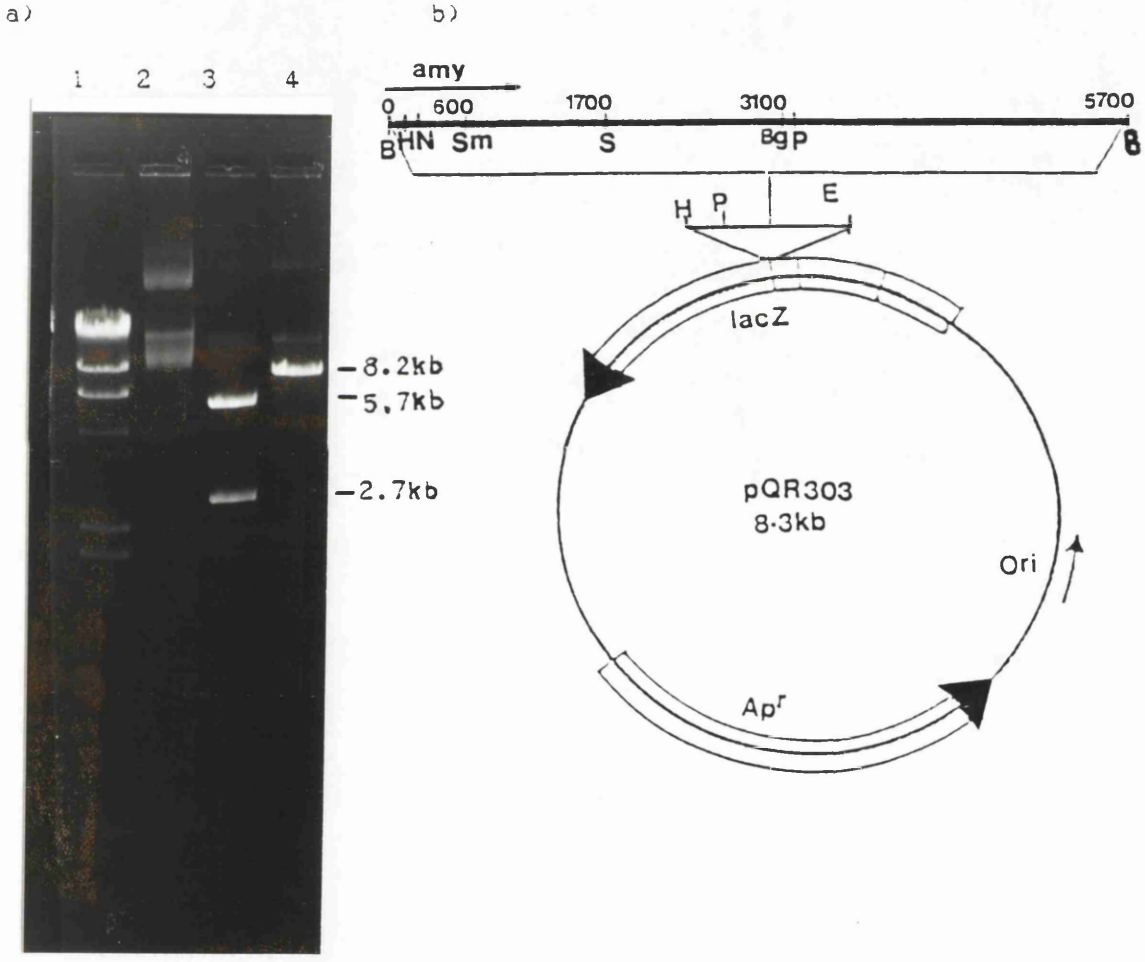

digestion (Fig.3.9). The same phenomenon was also seen when pQR304 and pQR313 plasmids were constructed (see Section 3.4). The results of this experiment suggested that the expression of the cloned *S. thermoviolaceus* CUB74 α -amylase gene in *E. coli* was from the *lacZ* promoter and not from its own promoter.

3.6 Localization of the cloned CUB74 α -amylase in *E. coli*

In order to locate the CUB74 α -amylase protein expressed in *E. coli*, pQR300-containing *E. coli* was grown in the low phosphate medium of Neu and Heppel (1964) and fractionated as described in Section 2.2. Each fraction was assayed for amylase activity by the plate assay (see Section 2.24.2) and for alkaline phosphatase activity as a periplasmic protein marker (see Section 2.23). The results of this experiment are shown in Table 3.1. They indicated that approximately 40% of amylase activity expressed by *E. coli* pQR300 was present in the culture supernatant (extracellular fraction) whereas the remaining amylase activity (60%) was located in the periplasm/cytoplasm fraction. No amylase activity was found in the membrane bound fraction. In addition, the results for the alkaline phosphatase activity (periplasmic protein marker) showed that 91% phosphatase activity was found in the periplasm/cytoplasm fraction, 9% in the extracellular fraction and none in the membrane-bound fraction.

The results of the alkaline phosphatase assay ensured that the cell fractionation procedure had worked. *E. coli* pUC8 was also processed in the same way as a control. No amylase activity was found in the assay conditions used in any of the fractions collected from the control.

3.7 Effect of IPTG on amylase production by *E. coli* pQR300

Results obtained from previous experiments (Sections 3.4 and 3.5)

Table 3.1 Amylase localization in *E. coli* pQR300.

Fraction	Alkaline phosphatase		Amylase	
	Unit	%	Unit	%
Supernatant	13.6	9	13.6	43
Periplasm/ Cytoplasm	138	91	18	57
Membrane-bound	0	0	0	0

E. coli pQR300 was grown in 40ml low phosphate medium of Neu and Heppel (1964) to an OD₄₅₀ of 1. It was spun down and the supernatant was collected. The cells were fractionated as described in Section 3.5. The collected fractions were assayed for amylase by the plate assay (see Section 2.24.3) and for alkaline phosphatase (see Section 2.23).

suggested that expression of the cloned CUB74 α -amylase gene in *E. coli* pQR300 had been from the *lacZ* promoter. The second question to answer was does it respond to induction by IPTG?.

E. coli pQR300 was grown overnight in 5ml nutrient broth cultures with and without 2mM IPTG. The supernatants were collected and the cells were sonicated. The supernatant and the sonicate fractions of each culture were assayed for amylase activity by the Somogyi method (Section 2.24.1). The results of this experiment are shown in Table 3.2. *E. coli* pUC8 was also processed in the same way. Surprisingly, IPTG induced the amylase production by only 16%. On plates, larger zones were obtained when *E. coli* pQR300 was grown in the presence of IPTG. To avoid the possibility that *E. coli* pQR300 might have been a constitutive mutant i.e lacking the *lacI* gene, It was streaked onto a minimal media plate. It grew very well which confirmed that the *lacI* repressor gene was still present as it resides on the F' plasmid carrying the proline biosynthesis genes. *E. coli* pQR300 was also able to use starch as a carbon source when it was substituted for glucose in the minimal media plate while *E. coli* pUC8 could not.

3.8 SDS-PAGE results

Culture supernatants of *E. coli* pQR300, *E. coli* pUC8 and *S. thermoviolaceus* CUB74 were analysed on the same protein gel (Fig.3.10). They were run in duplicates. One half of the gel which also contained molecular weight markers was stained with Coomassie Blue and the other half was treated with Triton x100 to reactivate the proteins (see Section 2.19). The reactivated protein gel was sandwiched against an agarose gel containing 0.5% potato starch and the sandwich was incubated overnight at 37°C (see Sections 2.19 and

Table 3.2 IPTG effect on amylase production by *E. coli* pQR300.

Fraction	α -amylase			
	-IPTG		+IPTG	
	Unit	%	Unit	%
Supernatant	1.94	36	2.86	45
Sonicate	3.38	64	3.54	55
Total	5.32	100	6.4	100

E. coli pQR300 was grown in 5ml nutrient broth overnight in the presence and absence of 2mM IPTG. The cultures were spun down and the supernatants were collected^e. The cell pellets were sonicated, spun down and the supernatant was collected as the sonicate fraction. The collected fractions were assayed for amylase activity by the Somogyi method (Section 2.24.1). *E. coli* pUC8 was also processed in the same way but no amylase activity was detected when the fractions were assayed by the Somogyi method.

2.20). The starch gel was then stained with iodine (Fig.3.10a). *E. coli* pQR300 and CUB74 showed a starch hydrolysis activity of the same size (50kDa) after renaturation of the proteins in the SDS polyacrylamide gel. Coomassie staining of protein bands in the gel revealed comigration of the amylase from *E. coli* pQR300 and CUB74, showing that the processing of the signal peptide by *E. coli* could be identical or differ by only a few amino acids. This could only be confirmed by sequencing the N-terminus of the secreted form of the α -amylase protein obtained from *E. coli* pQR300 and *S. thermoviolaceus* CUB74. There was no detectable activity from the pUC8-containing *E. coli* (control).

3.9 Summary

An α -amylase gene was isolated from *S. thermoviolaceus* strain CUB74 on a 5.7kb *Bam*HI DNA fragment. It was cloned in the *Bam*HI site of pUC8 (to yield pQR300) and expressed in *E. coli*. A summary of plasmid constructs obtained from subcloning experiments in *E. coli* and their ability to encode α -amylase is shown in Table 3.3. The expression of amylase in *E. coli* was not observed when the insert carrying the amylase gene was subcloned in the opposite orientation with respect to the *lacZ* promoter on pUC to yield pQR303, pQR304, and pQR313. On the other hand, while the expression of amylase seemed to be from the *lacZ* promoter and not from its own promoter, its production was not substantially induced by IPTG (by 16% only). The amylase product was found in the periplasm/cytoplasm fraction (60%) and the culture medium (40%) when expressed in *E. coli* pQR300. The smallest insert still expressing amylase was a 1.55kb *Hind*III/*Sph*I fragment (pQR312).

The molecular weight determination for the secreted α -amylase of

CUB74 gave a value of 50kDa for the mature protein which, giving the errors of MW determination by SDS-PAGE, was the same as that secreted into the culture medium by *E. coli* pQR300. This similarity may result from the ability of *E. coli* to process the signal peptide correctly as in the original *Streptomyces* host.

Fig.3.10. SDS-PAGE. 100 μ l of overnight *E. coli* culture supernatants and approximately 80 μ g of *S. thermoviolaceus* CUB74 crude supernatant (concentrated 100-fold) were loaded on the gel. Protein samples were run in duplicate on the same gel. a) Activity stain. An agarose gel containing potato starch which was overlaid on the reactivated half of the protein gel and stained with iodine (as described in Chapter Two). 1: *E. coli* pQR300; 2: *E. coli* pUC8 (control); 3: *S. thermoviolaceus* CUB74. b) One half of the gel which also contained molecular weight markers and stained with Coomassie Brilliant Blue R (as described in Chapter Two). 4: Protein size markers in kDa: bovine serum albumin (66), egg albumin (45), glyceraldehyde 3-phosphate dehydrogenase (36), carbonic anhydrase (29), and trypsinogen, PMSF treated (24). The arrow indicates the probable protein band that corresponds to the amylase zone.

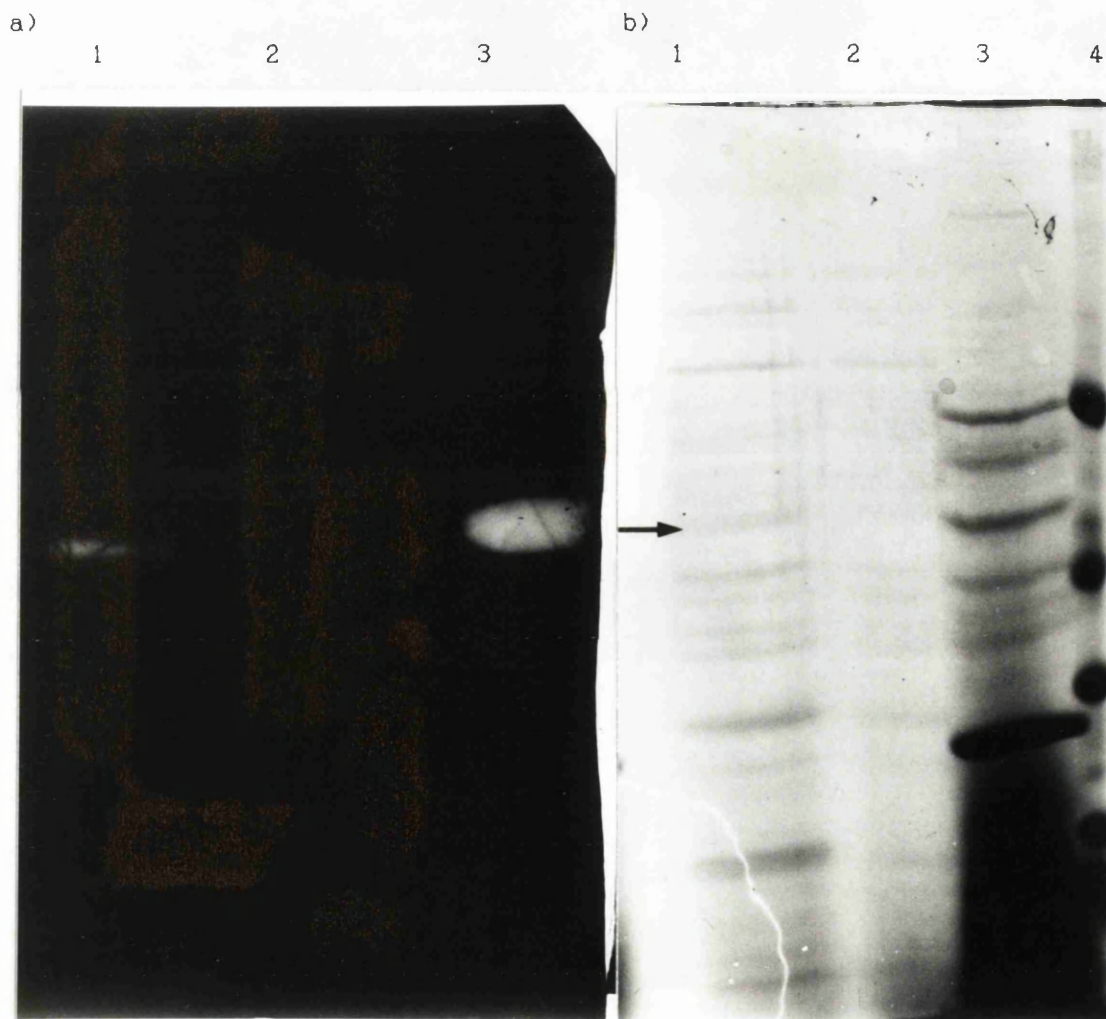

Table 3.3 Summary of plasmid constructs obtained from subcloning experiments in *E. coli*.

Plasmid	CUB74 DNA insert (kb)	P_{lac}	Amylase gene	Amylase production
pQR300	5.7	→	→	+
pQR301	3.1	→	→	+
pQR303	5.7	→	←	-
pQR304	3.1	→	←	-
pQR307	1.7	→	→	+
pQR312	1.55	→	→	+
pQR313	1.55	→	←	-
pQR314	1.1	→	→	-

Arrows indicate the orientation of the insert carrying the amylase gene with respect to the *lacZ* promoter (P_{lac}) on pUC8. The symbol (+) indicates the presence of amylase activity whereas (-) indicates the absence of amylase activity.

CHAPTER FOUR CHARACTERIZATION OF CUB74 AMYLASE

In this chapter, the effect of Ca^{++} and substrate on the thermostability of *S. thermoviolaceus* CUB74 α -amylase are described. The temperature optimum and the pH optimum in different buffers were also determined. In addition, the end-products of starch digestion by the enzyme were also analysed on paper chromatography.

4.1 Paper chromatography analysis of starch digestion with CUB74 amylase

Paper chromatography was performed as described in Materials and Methods (Section 2.21). In the time course experiment, concentrated α -amylase prepared from pQR300 supernatant was mixed with a soluble starch solution to a final concentration of 0.1 unit for each 1mg substrate. This mixture was incubated at 50°C and aliquots were removed at the time specified (0, 0.5, 1, 2, 4, 8, 24h). The time course aliquots were applied to an ascendant paper chromatography alongside a standard mixture containing glucose, maltose and maltotriose (Fig.4.1). The silver stained chromatogram (Fig.4.1) showed that at 0h there were no detectable sugar products but after 30min a sugar larger than maltotriose appeared as a distinct spot. At this time, only traces could be seen in the areas corresponding to maltotriose and maltose. After 1.5h, maltose and maltotriose spots appeared distinctly. As the incubation time progressed (2h, 4h), increasing amounts of maltotriose and maltose were accumulating. In addition to maltose and maltotriose, a spot corresponding to glucose

Fig.4.1 Paper chromatography. A concentrated amylase sample, prepared from *E. coli* pQR300 supernatant by precipitation with ammonium sulphate, was mixed with a soluble starch solution to a final concentration of 0.1 unit for each 1mg substrate. The mixture was incubated at 50°C and 20 μ l aliquots were removed at 0, 0.5, 1, 2, 4, 8, and 24h. These aliquots were analysed by paper chromatography as described in Section 2.21. sd: standard sugar mixtures; G1: glucose; G2: maltose; G3: maltotriose.

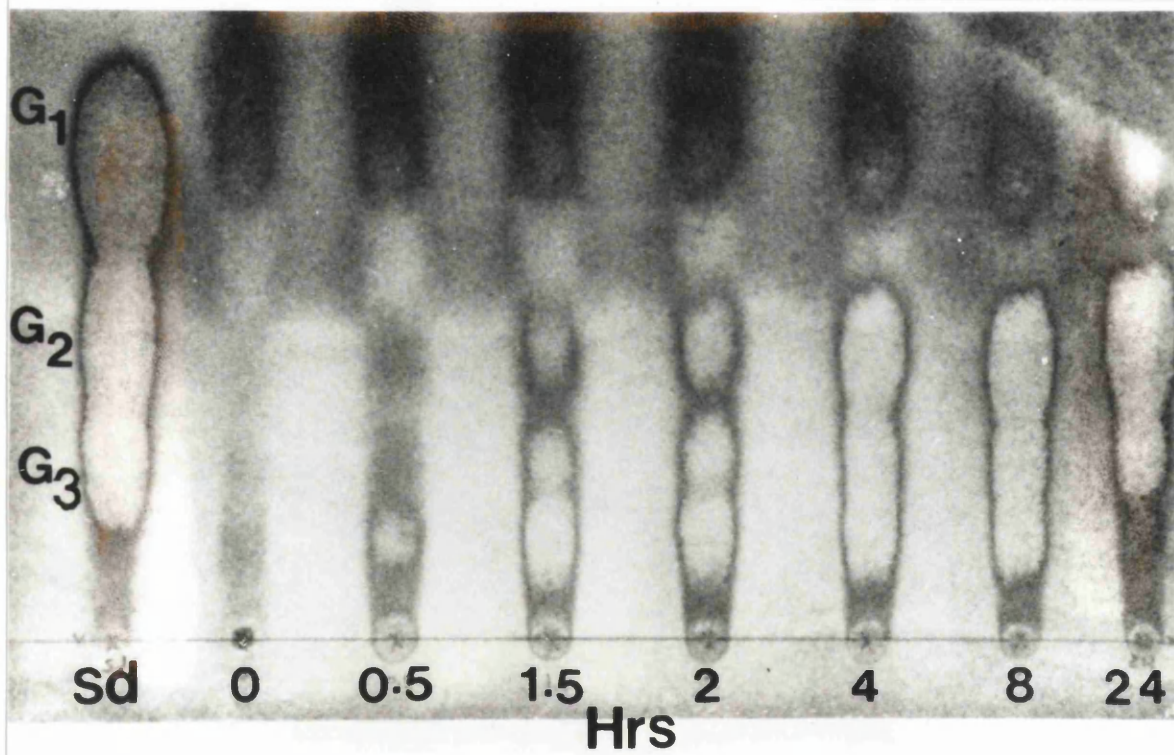

started to appear at 8h and became distinct at 24h, at which time the sugar (larger than maltotriose) which appeared at 0.5h disappeared. At the top section of the chromatogram, dark spots can be seen in all the lanes except in the standards lane (sd). This was usually encountered whenever protein containing samples were applied onto the chromatogram.

The results of the paper chromatography analysis of the products of starch digestion with CUB74 amylase from pQR300 suggested that the enzyme was an α -amylase as the major end-products were maltotetraose, maltotriose and maltose with maltose accumulating over extended periods while maltotetraose disappeared.

4.2 Temperature optimum

In order to determine the temperature optimum of α -amylase, an overnight culture of *E. coli* pQR300, grown in nutrient broth in the presence of ampicillin and IPTG, was sedimented and the supernatant was filtered. 500 μ l aliquots were taken out from the filtered supernatant and mixed with an equal volume of 1% (w/v) soluble starch made in 20mM Tris/HCl pH7.5, 5mM CaCl₂. The mixtures were incubated at different temperatures (37, 50, 60, and 70°C). The Somogyi assay was carried out as described in Section 2.24.1 and OD₆₀₀ readings were taken. A curve was obtained by plotting OD₆₀₀ values against temperatures (Fig.4.2). The highest activity obtained under these conditions was in the assay mixture that had been incubated at 60°C. From this experiment, it was concluded that the optimum temperature of the enzyme was 60°C in the conditions described.

4.3. pH optimum

In order to determine the pH optimum of α -amylase, a concentrated

Fig.4.2 Temperature optimum of amylase. 500µl aliquots taken from a filtered supernatant of an *E. coli* pQR300 overnight culture were mixed with an equal volume of a 1% (w/v) soluble starch made in 20mM Tris/HCl pH7.5, 5mM CaCl₂ and incubated at different temperatures, 37, 50, 60, and 70°C. Reagents were added as described in the Somogyi assay (Section 2.24.1) and the enzyme activity was determined. Enzyme activity is expressed in unit/ml (U/ml).

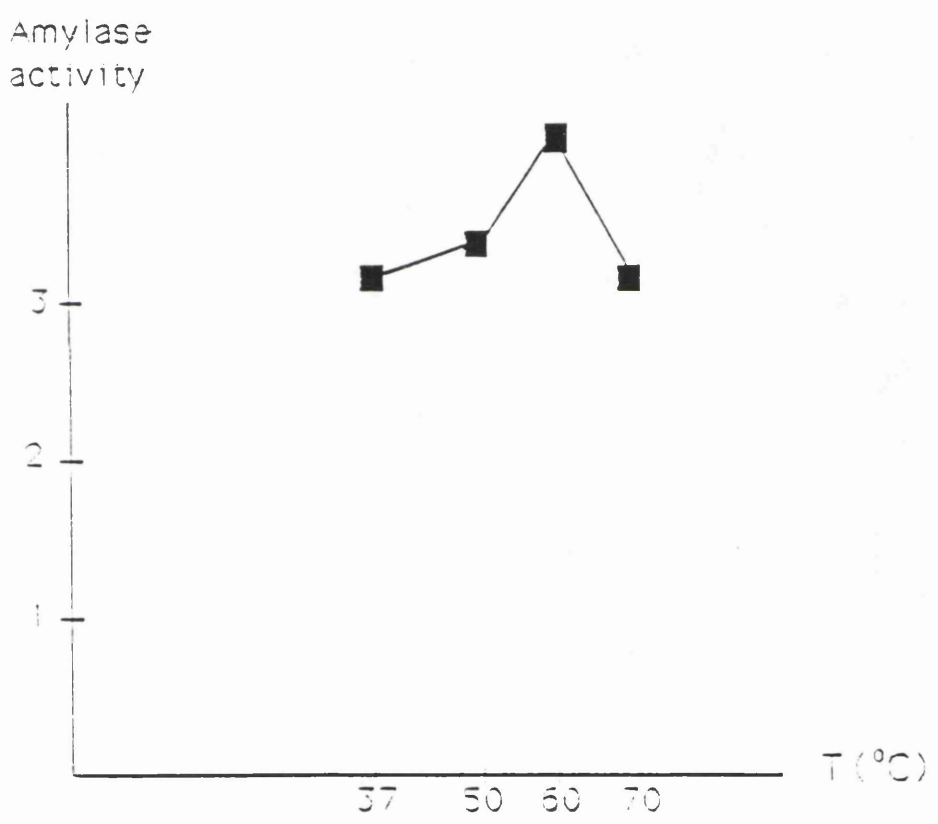

crude enzyme sample (1ml) prepared from the supernatant of *E. coli* pQR300 was passed through a nucleic acid purification (NAP10) column that had been equilibrated with H₂O. The proteins were eluted with 1.5ml H₂O. The aim of this purification step was to change the buffer (Tris/HCl) of the enzyme solution to water. The eluted enzyme solution was diluted to 15ml with H₂O and 500 μ l aliquots of this diluted enzyme solution were incubated with soluble starch in the presence of different buffers at different pH ranges. The results showed that the enzyme is most active at pH5.8 (Fig.4.3).

4.4 Thermostability of the α -amylase

Stability of the α -amylase to heat was investigated in the presence and absence of 5mM CaCl₂, in the presence and absence of 1% (w/v) substrate (soluble starch), and in the presence of both CaCl₂ and substrate.

4.4.1 Effect of temperature on enzyme activity

E. coli pQR300 was grown with and without 5mM CaCl₂ overnight. 500 μ l aliquots of their culture supernatants were preincubated at the temperature indicated (4, 37, 50, 60, 70, and 80°C) for 60min and then mixed with soluble starch (made in 20mM Tris/HCl pH7.5, 5mM CaCl₂) and assayed at 50°C as described in Section 2.24.1. The results of this experiment are shown in Table 4.1. They show that in the presence of 5mM CaCl₂, the amylase secreted by *E. coli* pQR300 retained 90% of its activity at 60°C and 70% of its activity at 70°C after one hour preincubation at these temperatures. Most of this activity was abolished above 80°C. They also show that in the absence of CaCl₂, the amylase activity rapidly fell at temperatures above 50°C.

Fig.4.3 Effect of pH on enzyme activity. A concentrated crude enzyme sample (1ml) prepared from the supernatant of *E. coli* pQR300 was passed through a Sephadex-based nucleic acid purification (NAP10) column that had been equilibrated with H₂O. The proteins were eluted with 1.5ml H₂O. The aim of this purification step was to change the buffer (Tris/HCl) of the enzyme solution to water. The eluted enzyme solution was diluted with H₂O and 500 μ l aliquots of this diluted enzyme solution were incubated with soluble starch in the presence of different buffers at different pH ranges. The starch solution was made as a 2.5% (w/v) stock solution in water plus 12.5mM CaCl₂ and diluted 5x in the assay mixture. The buffers were also made as stock solutions (2M Na acetate buffer, pH4.1-7.9; 0.2M phosphate buffer, pH5.8-8.0; 1M Tris/HCl buffer, pH6.5-9.0 and diluted in the assay mixture to a final concentration of 40mM. Each assay was made up to 1ml with H₂O and carried out at 50°C. Sodium acetate buffer is indicated by squares, phosphate buffer by open circles, and Tris/HCl buffer by dots.

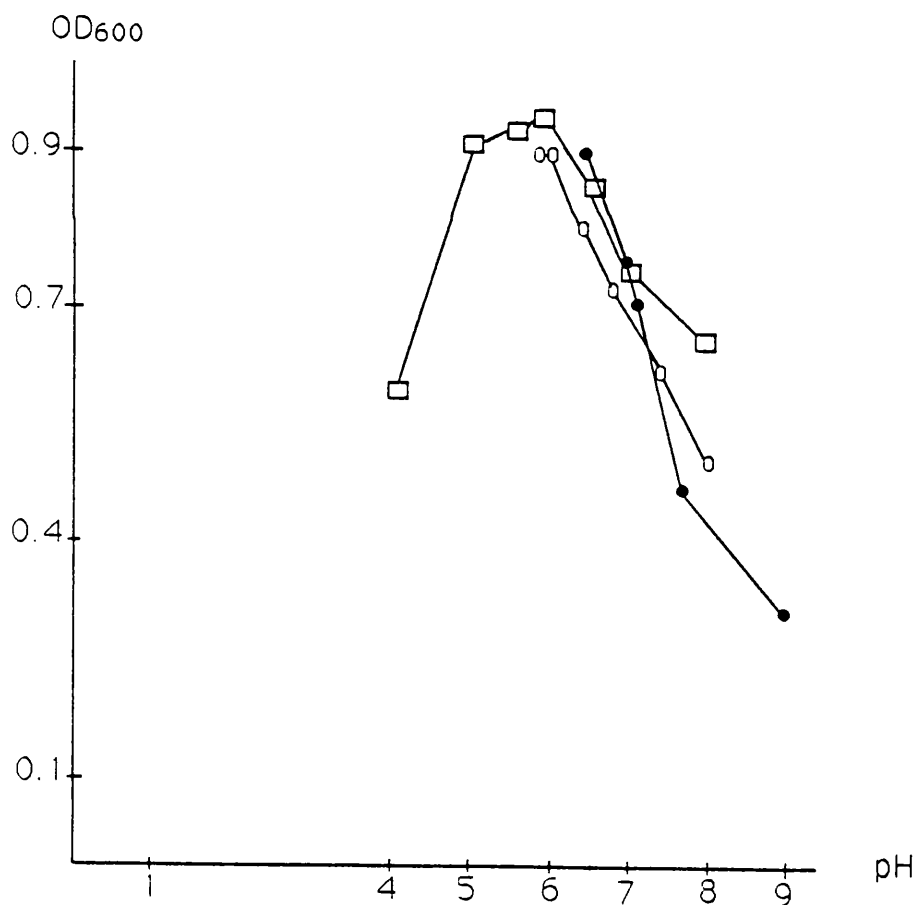

Table 4.1 Effect of temperature on α -amylase activity.

Preincubation temperature (°C)	α -Amylase activity		α -Amylase activity	
	-CaCl ₂		+CaCl ₂	
	U/ml	% Maximum activity	U/ml	% Maximum activity
4	3.62	88	2.5	88
37	4.1	100	2.84	100
50	3.64	89	2.58	90
60	0.62	15	2.52	89
70	0.52	13	2.0	70
80	0.1	2.0	0.3	11

E. coli pQR300 was grown in 5ml nutrient broth overnight in the presence and absence of 5mM calcium. 500 μ l aliquots of the culture supernatants were preincubated at the temperature indicated (4, 37, 50, 60, 70, and 80°C) for 60min and then mixed with soluble starch (made in 20mM Tris/HCl pH7.5, 5mM CaCl₂) and assayed at 50°C as described in Section 2.24.1. Amylase activity is expressed in unit/ml.

4.4.2 Effect of calcium on thermal stability of α -amylase

5ml cultures of *E. coli* pQR300 were grown in the presence and absence of 5mM CaCl₂. 500 μ l aliquots of their supernatants were incubated for the time indicated (0-22h) and then mixed with soluble starch (made in 20mM Tris/HCl pH7.5, 5mM CaCl₂) and assayed at 50°C as described in Section 2.24.1. The percentage of the remaining activity was plotted against the time of incubation. The results in Fig.4.4 show that in the absence of calcium, the enzyme lost 30% of its activity after 8h incubation at 50°C and it was totally inactive after 22h at 50°C and 2h at 60°C. They also show that in the presence of calcium, the enzyme was 100% stable after 22h incubation at 50°C and 8h at 60°C.

4.4.3 Effect of substrate on thermal stability of α -amylase

Supernatant from an overnight *E. coli* pQR300 culture grown in the absence of calcium was mixed with a 10% (w/v) soluble starch solution made in water. The final concentration of starch in the mixture (1ml) was 1% (w/v). Aliquots of this mixture were preincubated at each temperature (0 (control), 60, 70 and 87°C) for 1h and then assayed as described in the turbidity assay for α -amylase (Section 2.24.2). The results are shown in Table 4.2. The enzyme was 96% stable at 60°C and retained only 30% of its activity at 70°C. At 87°C, most of the enzyme activity was abolished (only 12% of activity was retained). If these results are compared with those shown in Table 4.1, it can be concluded that the enzyme is stabilised by starch (substrate).

4.4.4 Effect of calcium and substrate combined on thermal stability of α -amylase

Aliquots taken from the supernatant of the same *E. coli* pQR300 culture used in the previous assay (Section 4.4.3) were preincubated

Fig.4.4 Effect of calcium on thermal stability of amylase

E. coli pQR300 was grown in 5ml nutrient broth in the presence of 5mM CaCl₂. 500μl aliquots of their supernatants were preincubated at 50 and 60°C for the time indicated (1, 2, 4, 8, 22h) and the residual amylase activity was determined by the Somogyi method at 50°C (Section 2.24.1). 1: in the absence of calcium and at 60°C; 2: in the absence of calcium and at 50°C; 3: in the presence of calcium and at 60°C; 4: in the presence of calcium and at 50°C.

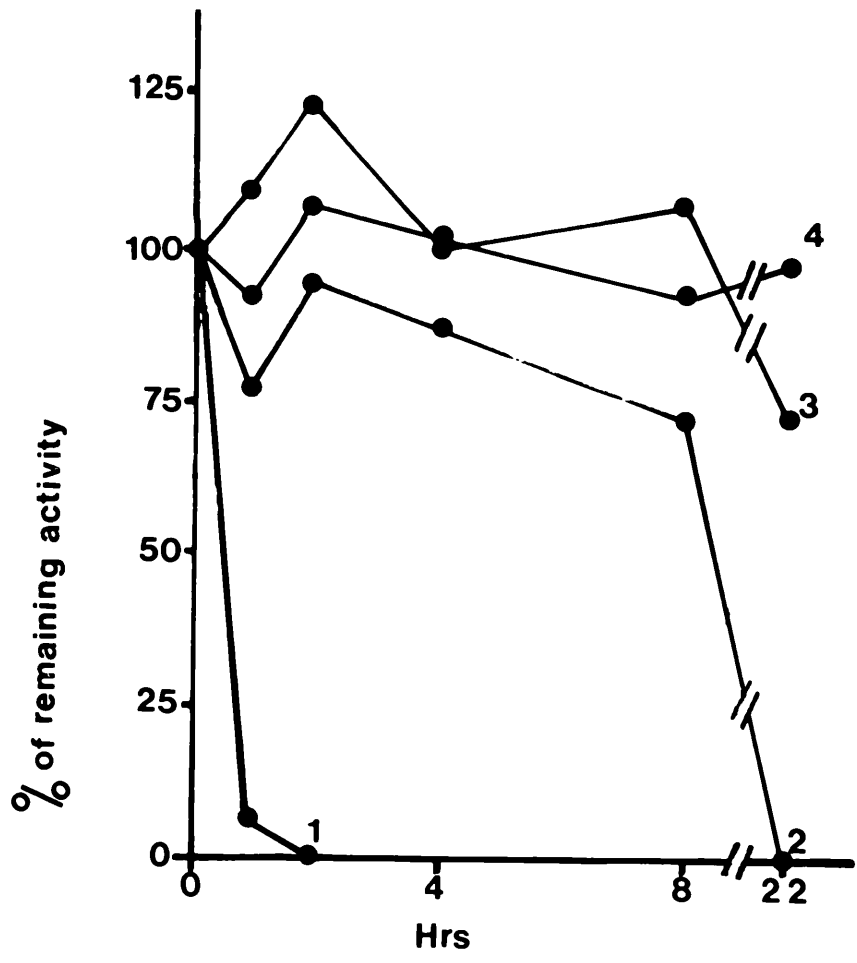

Table 4.2 Effect of starch on its own and together with calcium on thermal stability of α -amylase.

Preincubation temperature (°C)	Starch		Starch+Calcium	
	Amylase activity unit/ml	% MA	Amylase activity unit/ml	% MA
4	29.1	100	11.6	98
60	28	96	11.8	100
70	8.6	29	10.9	92
87	3.4	12	2.4	20

E. coli pQR300 was grown in 5ml nutrient broth overnight in the presence and absence of 5mM CaCl₂. The cells were sedimented and the supernatants were divided into 500 μ l aliquots. Starch was added to the aliquots to a final concentration of 1% (w/v). The mixtures were preincubated at the temperature indicated and then assayed for amylase activity by the turbidity method (see Section 2.24.2). MA: maximum activity.

in the presence of 1% (w/v) final concentration soluble starch and 5mM CaCl_2 for 1h at each temperature (0 (control), 60, 70 and 87°C). They were then assayed as described in Section 2.24.2 (turbidity assay for α -amylase). The results in Table 4.2 show that the enzyme retained more than 92% of its activity at 70°C. At 87°C, only 20% of activity was retained.

These results taken together with those in Section 4.4.1 show that starch and calcium combined have a greater effect on the thermostability of the enzyme than each individually.

4.5. Inhibition assay

Tendamistat is a mammalian α -amylase inhibitor (Hofmann *et al.*, 1985), isolated from the supernatant of *S. tendae* cultures. Since the paper chromatography experiment (Section 4.1) showed that the enzyme was an α -amylase, it was tested for inhibition by tendamistat. An enzyme sample, obtained from a CUB74 culture grown in NMMP supplemented with 1% (w/v) glucose plus 0.1% (w/v) maltotriose, was diluted to 1.4u/ml and divided into 100 μ l aliquots. The aliquots were mixed with 5 μ l tendamistat of different concentrations (0.35, 1.75, 3.5, 17.5, 35, and 70pmol) and incubated for 2min at 37°C. The remaining amylase activity was measured by the turbidity assay (Section 2.24.2) and compared with a control in which the inhibitor was substituted with 5 μ l H_2O . The results in Table 4.3 show that tendamistat inhibited the CUB74 α -amylase partially at concentrations 1.75 and 3.5pmol and completely at a concentration of 17.5pmol and above.

Table 4.3 Tendamistat assay

Inhibitor (pmol)	Amylase activity (U/ml)	% Residual activity
0.0	1.4	100
0.35	1.3	93
1.75	1.1	78
3.5	1.0	71
17.5	0.0	0
35	0.0	0
70	0.0	0

An overnight culture of *S. thermoviolaceus*, grown in NMMP supplemented with glucose and maltotriose, was spun down and the supernatant was diluted to 1.4u/ml and divided into 100 μ l aliquots. The aliquots were mixed with 5 μ l tendamistat of different concentrations and incubated for 2min at 37 $^{\circ}$ C. The mixtures were then assayed for amylase activity by the turbidity method (see Section 2.24.2). The control sample was mixed with 5 μ l H₂O instead of tendamistat (0.0pmol inhibitor) and processed in the same way.

4.6 Summary

CUB74 amylase was classified as an α -amylase from the results of paper chromatography. The temperature optimum of the enzyme was 60°C in the presence of calcium. Its pH optimum was 5.8 (in the sodium acetate buffer). Thermostability of the enzyme was increased in the presence of calcium and substrate. Finally, the enzyme responded to inhibition by tendamistat, which is a potent mammalian α -amylase inhibitor.

CHAPTER FIVE CLONING AND EXPRESSION OF *STREPTOMYCES THERMOVIOLACEUS*
(CUB74) α -AMYLASE GENE IN *S. LIVIDANS* TK24.

After the successful cloning and expression of *S. thermoviolaceus* (CUB74) α -amylase in *E. coli* (Chapter Three), the next step was to clone and express the amylase gene in a *Streptomyces* host. This would allow the study and dissection of the control region(s) of the gene and would permit investigation of the effect of different sugars and carbon sources on the expression of the gene in *Streptomyces*.

5.1 Subcloning in pQR1 and pIJ702 and expression in *S. lividans*

The first attempt to clone the 5.7kb *Bam*HI fragment carrying the amylase gene in *S. lividans* TK24 was made via pQR1 (see Appendix 3 for a restriction enzyme map of pQR1). pQR1 is a high copy-number shuttle vector made by cutting the *Streptomyces* plasmid pIJ702 and the *E. coli* plasmid pBR325 with *Pst*I and ligating the two plasmids together (Barallon and Ward, unpublished). The 5.7kb *Bam*HI fragment was isolated from pQR300 (see Chapter Three) by cutting with *Bam*HI and extracting the 5.7kb DNA fragment from an agarose gel. It was then ligated to pQR1 that had been cut with *Bgl*III. Two plasmid constructs, pQR308 and pQR309 (Fig.5.1), that had resulted from this experiment were found in *E. coli*. *E. coli* colonies containing either plasmid were resistant to tetracyclin (Tc^r) and to chloramphenicol (Cm^r) and they were amylase negative. pQR308 and pQR309 only differ by the orientation of the insert with respect to the *mel* promoter on pQR1. Both plasmids were used to transform *S. lividans* protoplasts.

Fig.5.1. Construction of plasmids pQR308 and pQR309. pQR308 and pQR309 were constructed by cloning the 5.7kb *Bam*HI fragment carrying *amy* in the *Bgl*III site of pQR1. a) Analysis of plasmids DNA on an agarose gel. 1: λ HindIII; 2: undigested pQR308 (control); 3: pQR308 digested with *Pst*I; 4: undigested pQR309 (control); 5: pQR309 digested with *Pst*I. b) Restriction enzyme maps of pQR308 and pQR309 plasmids. All abbreviations are as described in the legend of Fig.3.5. The arrows represent the orientation of *amy* and the melanin gene (*mel*) on the pIJ702 part (filled arch) of pQR1 and the origin of replication (Ori) on the pBR325 part (open arch) of pQR1. see Appendix 3 for a schematic diagram of pQR1.

a)

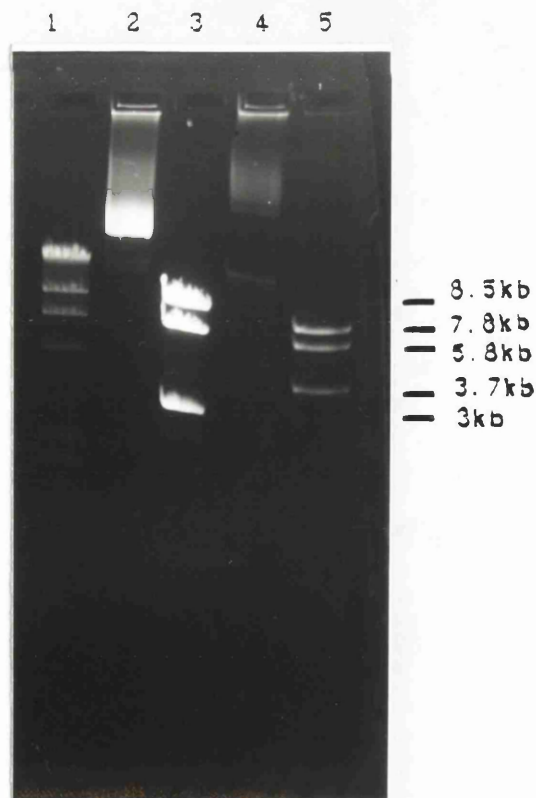

b)

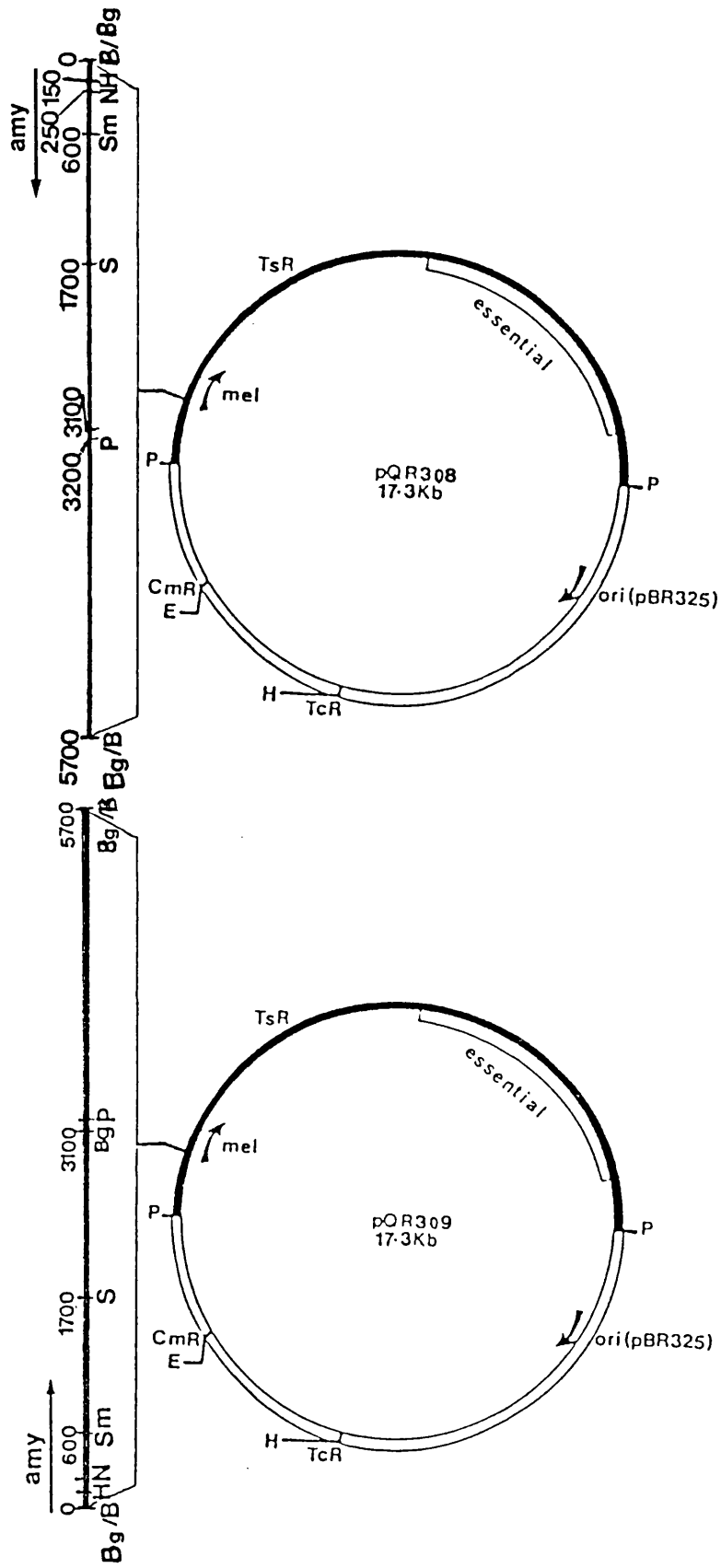

In *S. lividans*, both plasmid constructs were unstable and underwent deletions which reduced their sizes to approximately 5kb. The cause of this instability was not clear. It could have been due to unstable sequences present on the insert or the plasmid vector itself (pQR1) may have become unstable after cloning a relatively large insert (5.7kb) in it. Several attempts to clone the 5.7kb DNA fragment in the *Bgl*III site of pIJ702 (see Appendix 4 for a restriction map of pIJ702) on its own and screen for Ts^r and melanin negative *S. lividans* colonies failed as no transformants were obtained. Therefore, a 1.7kb *Bam*HI/*Sph*I fragment carrying the amylase gene and isolated from pQR307 (see Chapter Three) was ligated to pIJ702 that had been cut with *Bgl*III and *Sph*I. This resulted in a plasmid construct pQR311 (Fig.5.2) which encoded α -amylase in *S. lividans*. As a result of cloning in the *Bgl*III site of pIJ702, the melanin gene was disrupted and *S. lividans* containing pQR311 was melanin negative. A comparison between starch hydrolysis zones produced by *S. lividans* containing pQR311 and *S. lividans* containing pIJ702 (control) is shown in Fig.5.3. Large zones were seen around *S. lividans* pQR311 whereas the control (pIJ702) produced very small zones (Fig.5.3). In pQR311, the amylase gene was cloned in the opposite orientation to the *mel* promoter but it was still not clear whether amylase expression in *S. lividans* containing pQR311 was from its own promoter or from another promoter situated on pIJ702 (see Chapters Six and Seven). The smallest insert still expressing amylase in *E. coli* (1.55kb *Hind*III fragment in pQR312; see Chapter Three) was also subcloned in pQR1. The DNA fragment was isolated on an *Eco*RI/*Hind*III segment from pQR317 (see Fig.5.4 for constructing pQR317) and cloned in pQR1 that had been cut with the

Fig.5.2. Construction of plasmid pQR311. pQR311 was constructed by cloning a 1.7kb *Bam*HI/*Sph*I fragment carrying *amy* into pIJ702 that had been cut with *Bgl*III and *Sph*I. a) Analysis of pQR311 DNA on an agarose gel. 1: pQR311 double-digested with *Bam*HI and *Sph*I; 2: undigested pQR311 (control); 3: λ *Hind*III. It is an incomplete digestion and the top band (7.5kb) is actually the linear form of the plasmid. b) Restriction enzyme map of pQR311. The arrows represent the orientation of *amy* and the melanin (*mel*) and thiostrepton resistance (*Ts*^r) regions on pIJ702. All abbreviations are as described in the legend of Fig.3.5. See Appendix 4 for a schematic diagram of pIJ702.

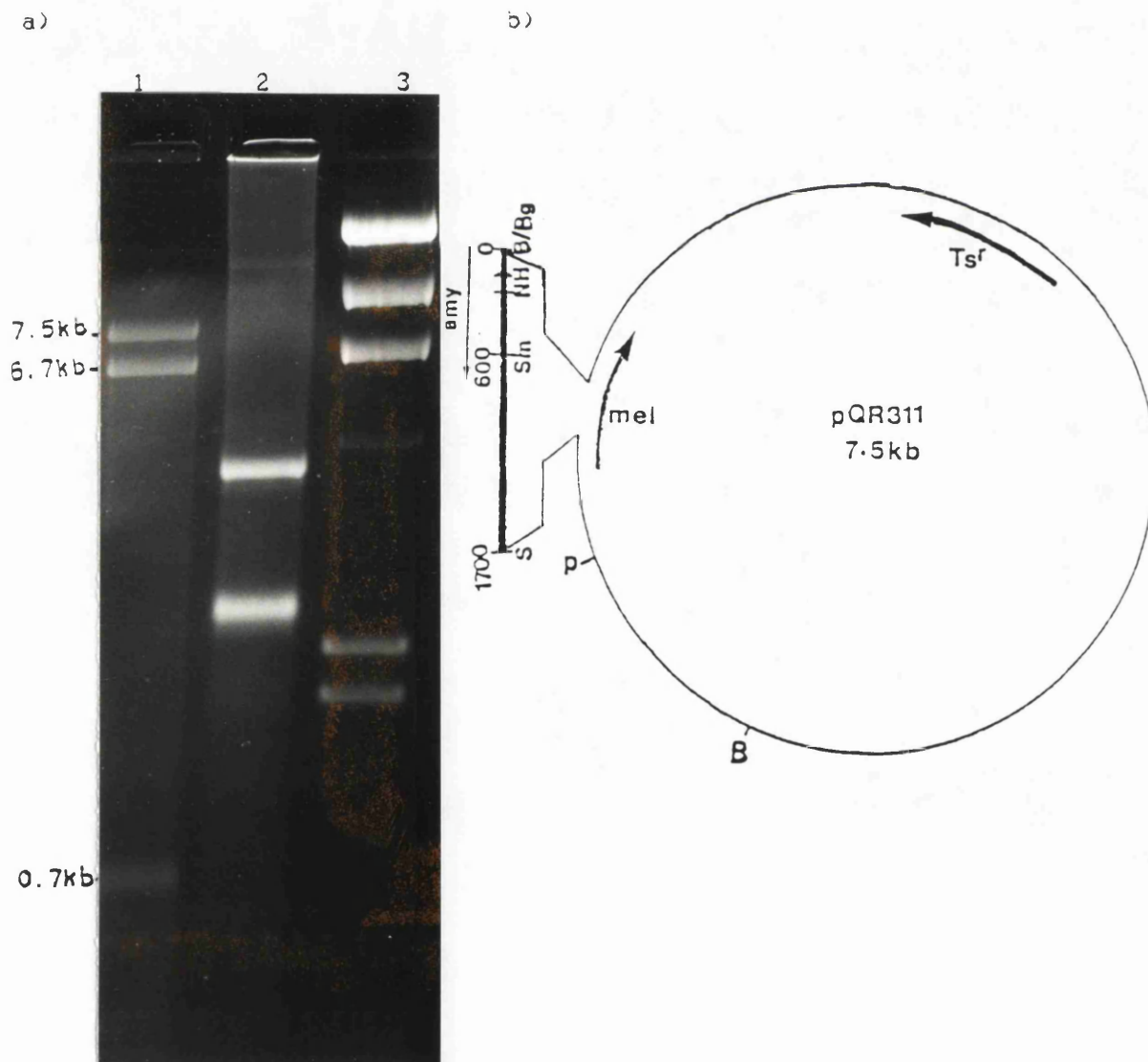

Fig.5.3. Comparison between amylase zones produced by *S. lividans* pQR311 and *S. lividans* pIJ702 (control). *Streptomyces lividans* was grown for four days on R2YE plates that had been supplemented with potato starch and thiostrepton. The plates were then stained with iodine.

pQR311

pIJ702

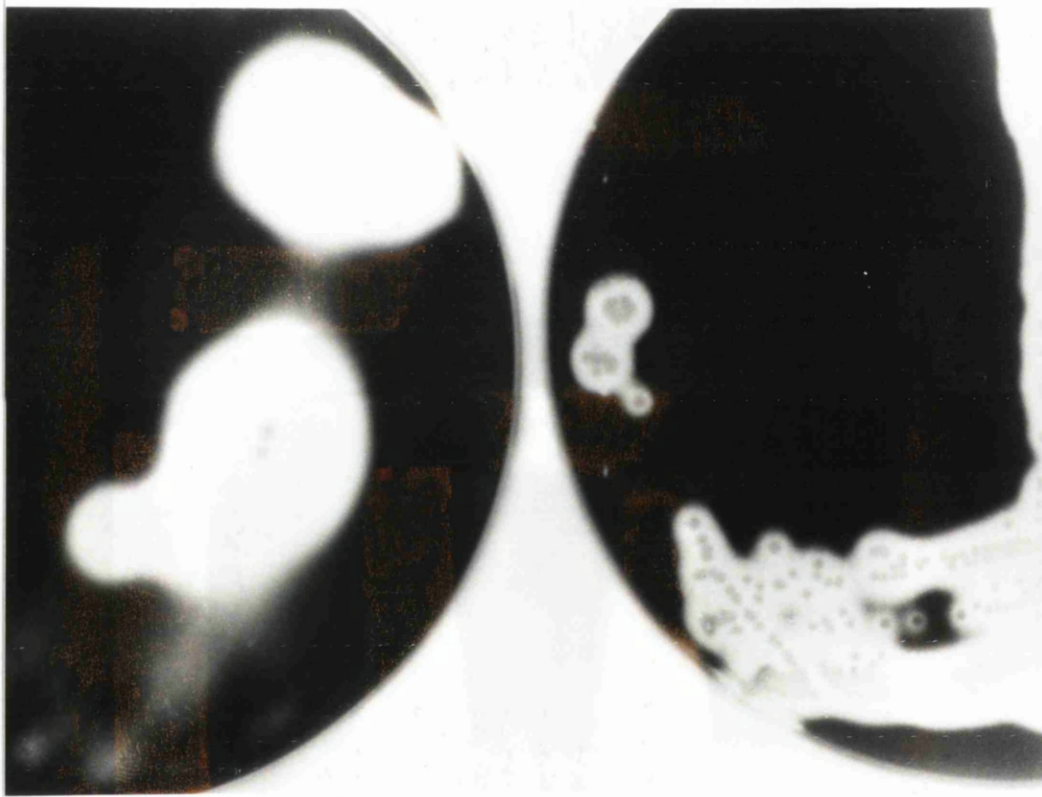
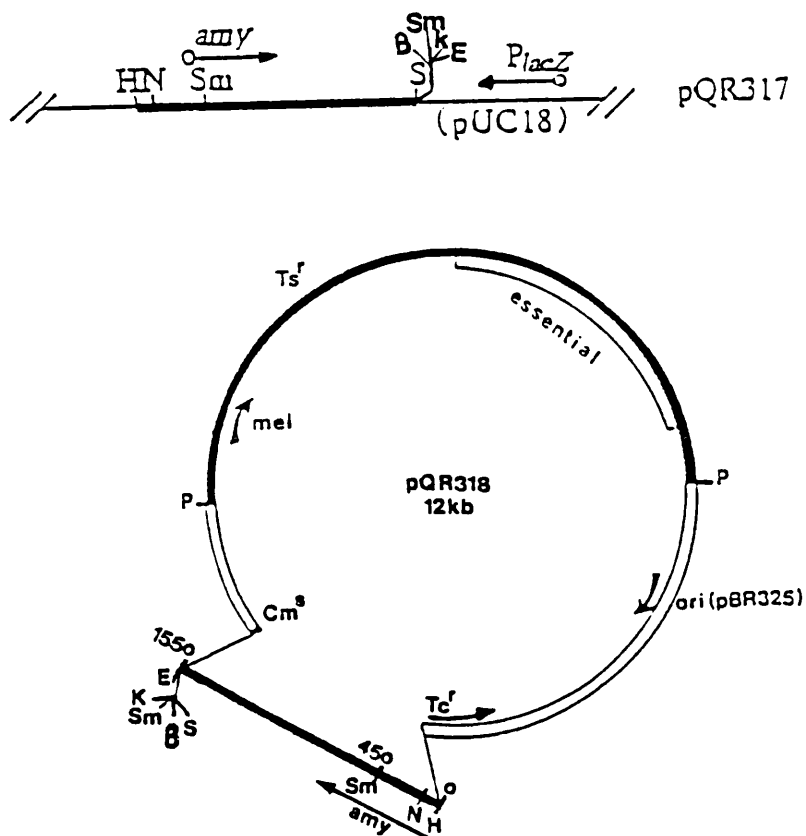

Fig.5.4. Construction of plasmid pQR318. pQR318 was constructed in two steps. In the first step, a *Hind*III site which is close to the polylinker in pQR313 (Fig.3.8) was removed by digesting pQR313 with *Sph*I and reinserting to yield pQR317. In the second step, the 1.55kb insert was removed from pQR317 on an *Eco*RI-*Hind*III fragment and ligated to pQR1 that had been cut with the same enzymes to yield pQR318. *E. coli* pQR318 was Tc^r Cm^s and amylase negative. P_{lacZ} : promoter of *lacZ* on pUC18. See Appendix 3 for a schematic diagram of pQR1. All abbreviations are as described in the legend of Fig.3.5.



same enzymes. The resulting plasmid pQR318 (Fig.5.4) was isolated from *E. coli* (amylase negative, Tc^r Cm^m) and introduced into *S. lividans*. In *S. lividans*, pQR318 was relatively stable and encoded α -amylase. A comparison between amylase zones produced by *S. lividans* pQR318 and *S. lividans* pQR1 (control) is shown in Fig.5.5. Expression of α -amylase from pQR318 in *S. lividans* could have been due to readthrough from a promoter situated on pBR325 and functional in *S. lividans* (see Chapters Six and Seven). *S. lividans* pQR318 produced even a larger α -amylase zones than that produced by *S. lividans* pQR311.

5.2 SDS-PAGE

Concentrated protein samples isolated from supernatants of *S. lividans* pIJ702 (control), *S. lividans* pQR311, and *S. thermoviolaceus* (CUB74) liquid cultures were analysed on a 12% (w/v) polyacrylamide gel. They were run in duplicates. One half of the gel which also contained MW protein markers was stained with Coomassie stain (Fig.5.6a) and the other half was treated with Triton X100 to reactivate the proteins (Section 2.20). The reactivated half was sandwiched against a starch/agarose gel and incubated overnight at 37°C. The starch gel was then stained with iodine solution (Fig.5.6b). This experiment showed that extracellular enzymes of *S. lividans* pQR311 and CUB74 give starch hydrolysis zones which correspond to protein bands of the same size (Fig.5.6). *S. lividans* pIJ702 (control) did not produce any starch hydrolysis zone in this system. This experiment suggested that *S. lividans* can process the α -amylase protein correctly to the mature form found in the parent bacterial strain *S. thermoviolaceus* (CUB74).

Fig.5.5. Comparison between amylase zones produced by *S. lividans* pQR318 and *S. lividans* pQR1 (control). *Streptomyces lividans* was grown at 30°C for three days on tryptone soya plates that had been supplemented with potato starch and thiostrepton. The plates were then stained with iodine.

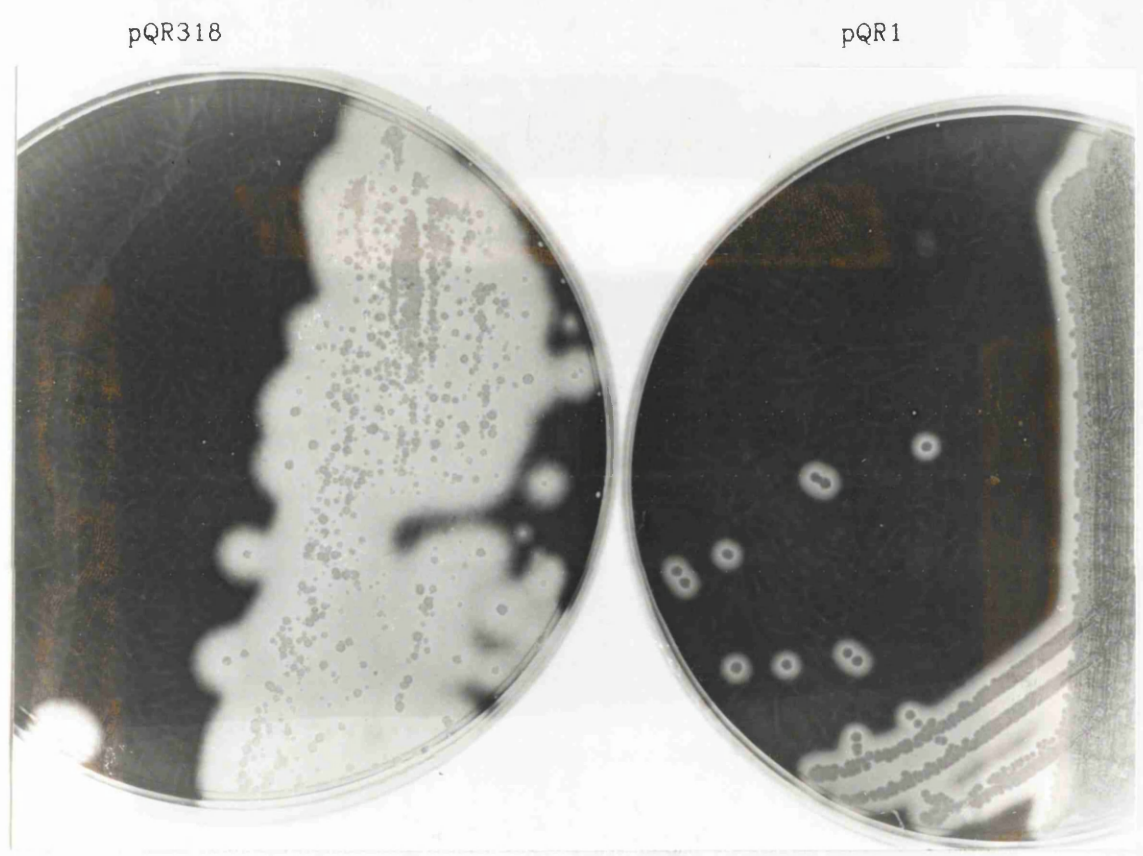

5.3 Regulation of CUB74 α -amylase in *S. lividans*

In order to study regulation of CUB74 α -amylase in *S. lividans*, the amylase gene had to be cloned in a low copy-number *Streptomyces* plasmid. The plasmid used for this purpose was the shuttle vector pIJ903 (see Appendix 5 for a restriction map of pIJ903). All plasmid constructs obtained from subcloning in this shuttle vector were first propagated and isolated from Ap^r *E. coli* colonies and then introduced into *S. lividans* and selected for on thiostrepton plus starch plates. In *E. coli*, the pIJ903-based constructs did not produce amylase.

5.3.1 Subcloning in the low copy-number plasmid pIJ903

The first recombinant plasmid constructed for amylase regulation study was pQR319. In order to construct pQR319, the amylase gene was first isolated from pQR307 (see Chapter Three) on a 1.7kb *Bam*HI/*Hind*III fragment by cutting to completion with *Bam*HI and partially with *Hind*III. This fragment was then subcloned into pIJ903 that had been cut to completion with *Bam*HI and *Hind*III (Fig.5.7) to form pQR319. *S. lividans* containing pQR319 was amylase positive. The whole 5.7kb *Bam*HI fragment carrying the amylase gene and isolated from pQR300 (see Chapter Three) was also subcloned into pIJ903 that had been cut with *Bam*HI and dephosphorylated (Section 2.12). Two plasmid constructs from this experiment were found in *E. coli*, pQR322 and pQR323 which only differ by the orientation of the insert with respect to the ampicillin promoter on pIJ903 (Fig.5.8). Both plasmids were taken up by *S. lividans* without undergoing any rearrangements or deletions. *S. lividans* pQR322 and pQR323 were amylase positive. A comparison between amylase zones produced by *S. lividans* pQR319, pQR322, pQR323, and pIJ903 (control) is shown in Fig.5.9.

Fig.5.7. Construction of plasmid pQR319. pQR319 was constructed by cloning a 1.7kb *Bam*HI/*Hind*III carrying *amy* into pIJ903 cut with the same enzymes. a) Analysis of pQR319 DNA on an agarose gel. 1: λ *Hind*III; 2: pQR319 digested with *Hind*III; 3: pQR319 double-digested with *Bam*HI and *Eco*RI. b) Restriction enzyme map of pQR319. amp: ampicillin region on the pBR327 part of pIJ903; R: replication region; F: fertility region; T+Po: transfer plus pock formation region; St: stability region. Other abbreviations are as described in the legend of Fig.3.5. See Appendix 5 for a schematic diagram of pIJ903.

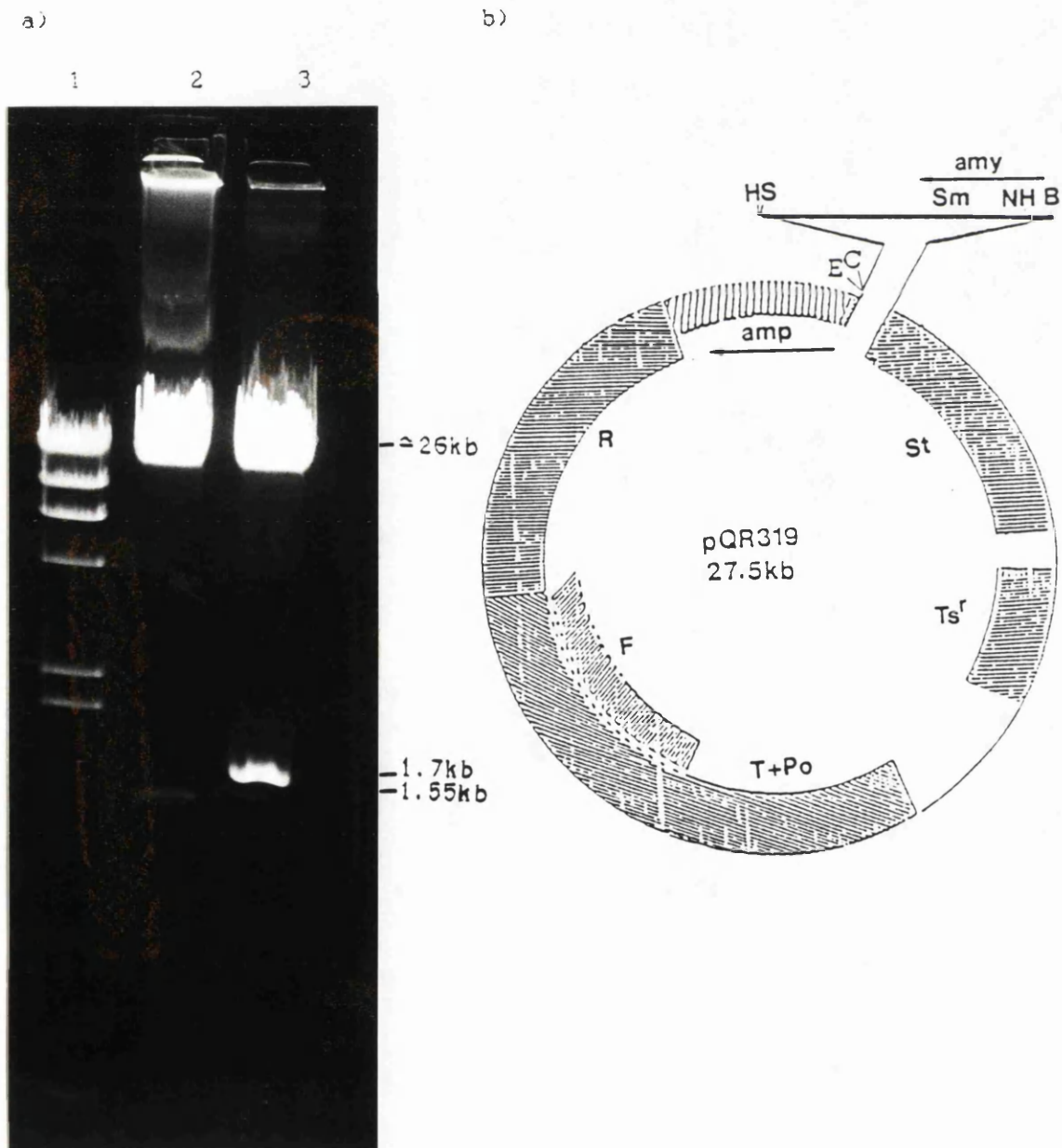

Fig.5.8. Construction of plamids pQR322 and pQR323. These plamids were constructed by cloning the 5.7kb *Bam*HI fragment carrying the amylase gene into the *Bgl*III site of the shuttle vector pIJ903. pQR322 and 323 only differ by the orientation of the insert. All abbreviations are as described in the legends of Fig.3.5 and Fig.5.7.

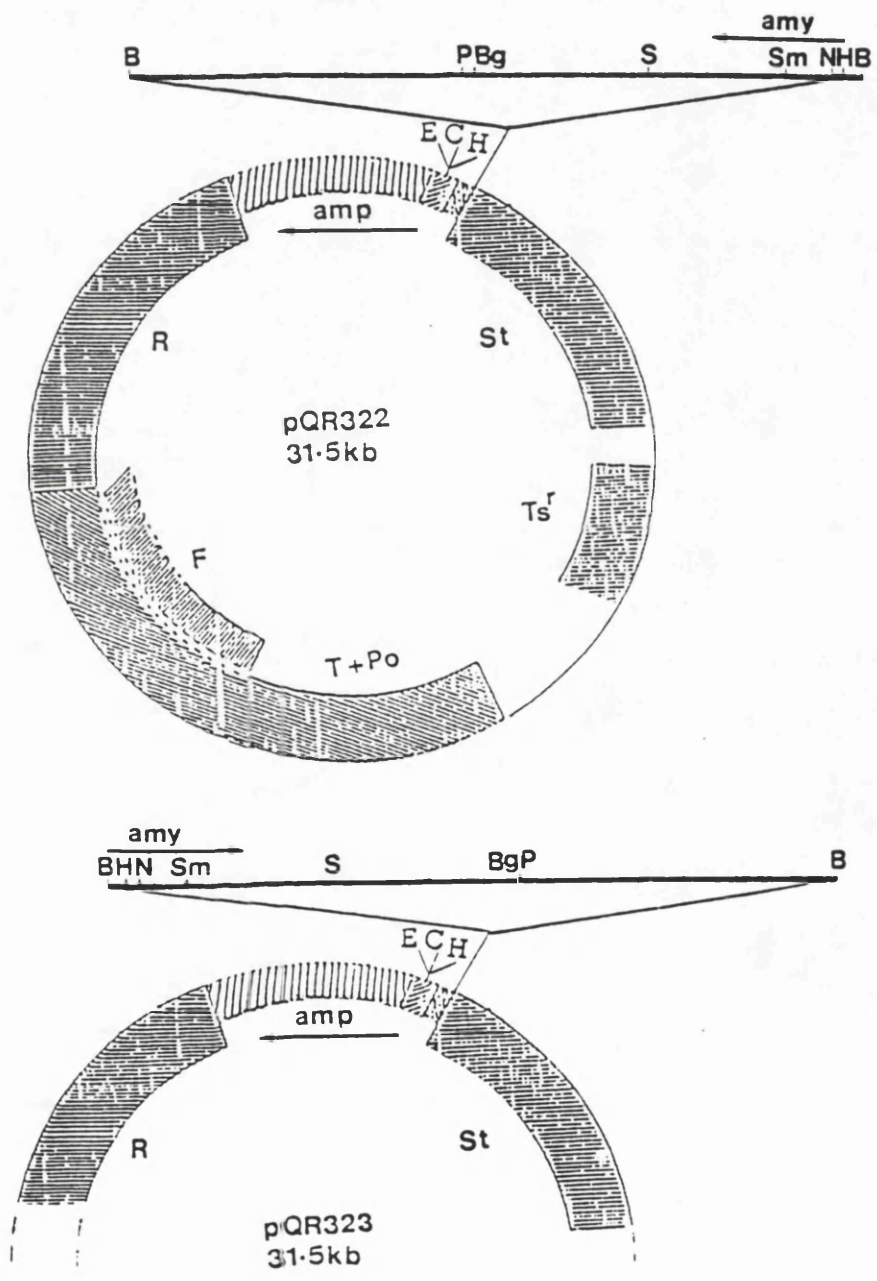
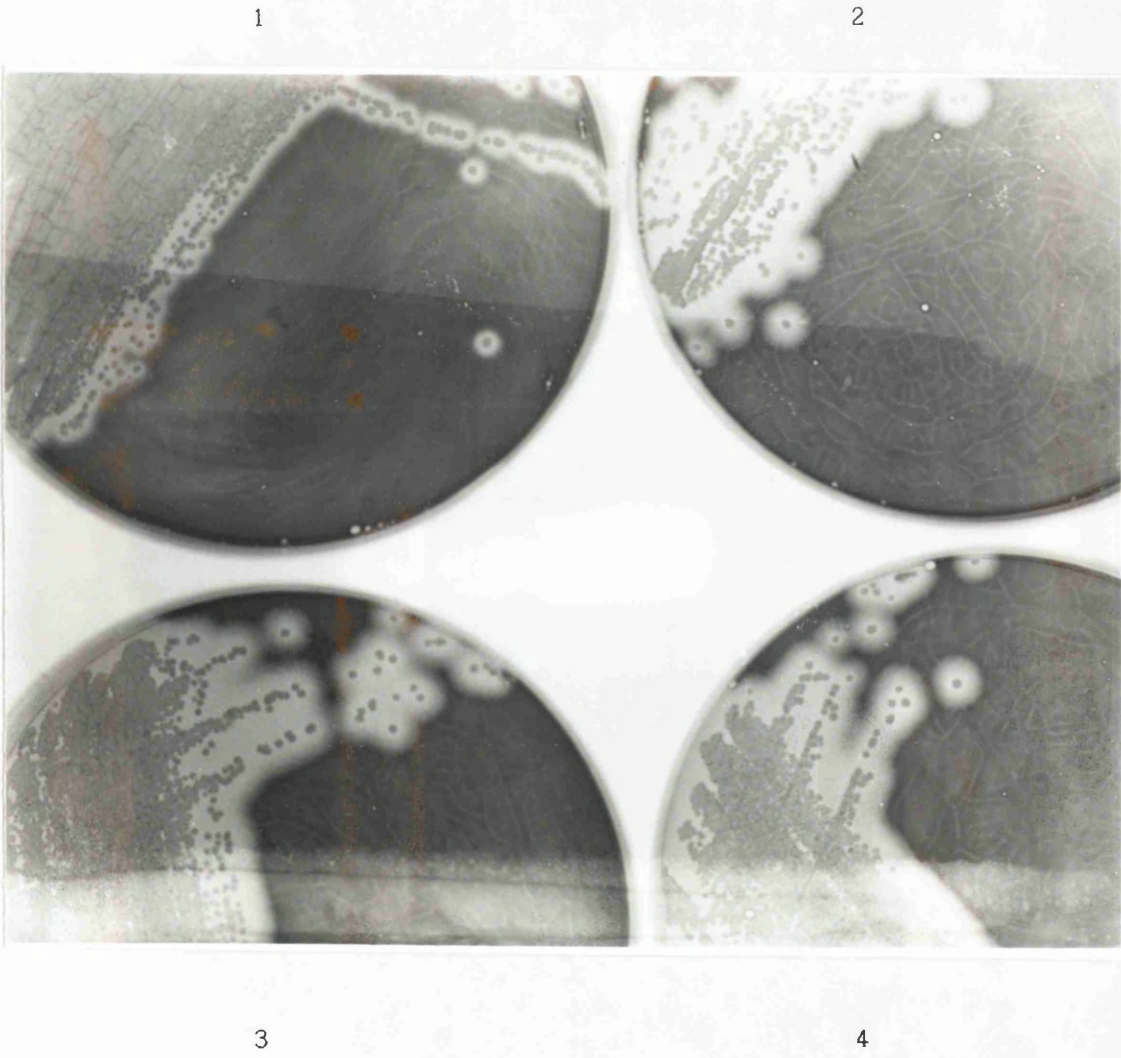

Fig.5.9. Comparison between amylase zones produced by *S. lividans* pIJ903 (control; 1), pQR319 (2), pQR323 (3), and pQR322 (4). *S. lividans* was grown for three days at 30°C on tryptone soya plates which had been supplemented with potato starch and thiostrepton. The plates were then stained with iodine.



5.3.2 Results of α -amylase induction in *S. lividans* and *S.*

thermoviolaceus

For studying induction in *S. thermoviolaceus* (CUB74), CUB74 spores were collected and pregerminated. They were resuspended in 5ml 0.05M TES buffer pH8.0, incubated for 10min at 50°C, and added to an equal volume pregermination medium (2% (w/v) yeast extract, 2% (w/v) Casaminoacids, 0.02M CaCl₂). They were incubated at 50°C with shaking for 2-3h. The pregerminated spores were sedimented, resuspended in sterile H₂O and used to inoculate 700ml NMMP supplemented with 1% (v/v) glycerol (Section 2.2). After 16h growth at 50°C, the culture was divided into 100ml aliquots, each supplemented with 1% (v/v) glycerol and 0.1% (w/v) potential inducer, none (control), glucose, maltose, maltotriose, maltotetraose, maltopentaose or cellobiose. 1ml was removed from the 16h culture as a control. The 100ml aliquots were allowed to grow for a further 2h at the same temperature and 1ml was removed from each aliquot. All 1ml samples collected were spun down and the supernatants were assayed for amylase activity by the turbidity assay (Section 2.24.2). The pellets were washed with 1ml H₂O, resuspended in 1ml H₂O and sonicated for 30sec and assayed for total cell proteins by a modified Biuret method as described in Section 2.25 (Herbert *et al.*, 1971).

In CUB74, the smallest sugar molecule that induced α -amylase was maltotriose (Table 5.1). 0.1% (w/v) maltotriose induced α -amylase by approximately 9x. Other oligosaccharides with 1,4- α glucosidic bonds (maltotetraose and maltopentaose) also induced α -amylase (Table 5.1). Cellobiose (two glucoses linked by 1,6- β glucosidic bonds), glucose and maltose had no effect on α -amylase production in CUB74. Further

Table 5.1 Results of induction in *S. thermoviolaceus* CUB74

PI (0.1%)	Total cell protein (mg/ml) 2h*	Amylase activity (U/ml) 2h*	Specific activity (U/mg ⁻¹ total protein) 2h*	IR
Control	0.48	0.86	1.8	1.0
Glucose	0.54	0.81	1.5	0.8
Maltose	0.48	1.1	3.0	1.7
Maltotriose	0.54	9.0	16.7	9.3
Maltotetraose	0.57	7.2	12.63	7.0
Maltopentaose	0.55	7.8	14.2	7.9
Cellobiose	0.49	0.63	1.3	0.7

* : Pregerminated spores of CUB74 were grown for 16h in NMMP (in a 700ml volume) supplemented with 1% (v/v) glycerol. The culture was then divided into 100ml aliquots, each of which was supplemented with glycerol (to 1%, v/v) and potential inducer (to 0.1%, w/v). 1ml was removed from the 16h culture to be assayed later. The aliquots were allowed to grow for a further 2h (i.e. 18h growth in total). A 1ml sample was removed from each culture and assayed for total cell protein as described in Section 2.25 and for amylase activity as described in Section 2.24.2. The 1ml 16h sample was also assayed in the same way and gave a value of 0.46mg/ml for protein concentration and 0.73U/ml for amylase activity (specific activity of 1.6U/mg⁻¹ total cell protein).

PI = Potential inducer; IR (Induction ratio) = (specific activity 2h after supplementation with inducer/specific activity at 16h)/(specific activity of control at 18h/specific activity of control at 16h).

growth of CUB74 cultures (4h, 9h) after supplementation with sugar resulted in disappearance of amylase activity in their supernatants (data not shown). This could have been due to several factors, the most probable of which is protease activity digesting the induced amylase protein.

For studying induction in *S. lividans* harbouring pQR319, pQR322 or pQR323, spores obtained from these strains were pregerminated as described for CUB74 with the only difference being that after adding the germination medium the spores were grown at 37°C. The pregerminated spores were also grown as described for CUB74 but at 30°C. As shown in Table 5.2, none of the sugars used induced α -amylase in *S. lividans* containing pQR319. Similar results were obtained for *S. lividans* pQR322 and pQR323 (data not shown).

Failure to induce α -amylase in *S. lividans* containing pQR319, pQR322, and pQR323 could have been due to the absence of other components needed for induction and encoded by sequences beyond the 5.7kb *Bam*HI fragment or the absence of sequences from the control region of the amylase gene (see Chapter Seven).

5.3.3 Effect of carbon source on α -amylase induction in *S.*

***thermoviolaceus* (CUB74)**

CUB74 spores were pregerminated as described in Section 5.3.2 and resuspended in sterile H₂O. They were then used to inoculate 6x100ml liquid NMMP cultures of CUB74. Each culture was supplemented with a different carbon source (glucose, mannitol, glycerol, arabinose, fructose, or none) to a final concentration of 1% (w/v). After 16h growth at 50°C, each culture was divided into 2x40ml aliquots, one of which was supplemented with the same carbon source to 1% (w/v) and the

Table 5.2 Results of induction in *S. lividans* pQR319

PI (0.1%)	Total cell protein (mg/ml) 41h*	Amylase activity (U/ml) 41h*	Specific activity (U/mg ⁻¹ total protein) 41h*	IR
Control	0.43	1.75	4.0	1.0
Glucose	0.415	1.4	3.37	0.84
Maltose	0.485	1.45	2.99	0.74
Maltotriose	0.445	1.4	3.14	0.78
Maltotetraose	0.45	1.5	3.33	0.83
Maltopentaose	0.735	1.7	2.3	0.57
Cellobiose	0.23	1.35	5.87	1.46

* : Pregerminated spores of *S. lividans* pQR319 were grown for 39h in NMMP (in a 800ml volume) supplemented with 1% (v/v) glycerol. The culture was then divided into 100ml aliquots, each of which was supplemented with glycerol (to 1%, v/v) and potential inducer (to 0.1%, w/v). 1ml was removed from the 39h culture to be assayed later. The aliquots were allowed to grow for a further 2h (i.e. 41h growth in total). A 1ml sample was removed from each culture and assayed for total cell protein as described in Section 2.25 and for amylase activity as described in Section 2.24.2. The 39h 1ml sample was also assayed in the same way. It gave a value of 0.37mg/ml for protein concentration and 1.45U/ml for amylase activity (specific activity of 3.9U/mg⁻¹ total cell protein).

PI = Potential inducer; IR (Induction ratio) = (specific activity 2h after supplementation with inducer/specific activity at 39h)/(specific activity of control at 41h/specific activity of control at 39h).

other with the same carbon source plus 0.1% (w/v) inducer (maltotriose). They were allowed to grow for a further 2h and 1ml samples were collected and processed as described in Section 5.3.2. The results in Table 5.3 show that only mannitol actually repressed α -amylase induction whereas the other carbon sources tested did not have any effect.

5.4. Summary

α -Amylase responds to induction and repression in its natural host *S. thermoviolaceus* CUB74. The smallest inducing sugar is maltotriose, whereas maltose did not have any effect. The carbon source that represses induction of amylase in CUB74 is mannitol. The CUB74 α -amylase gene has been cloned and expressed in *S. lividans* via high (pIJ702 and pQR1) and low (pIJ903) copy-number vectors. Production of this enzyme in the new host could not be induced by any of the sugars tested.

It was found that α -amylase can also be expressed in *S. lividans* from another promoter situated in the *E. coli* part (pBR325) of the shuttle vector pQR1 (see Chapter Six).

Table 5.3 Carbon source effect on α -amylase production in CUB74

Carbon source (1%, w/v)	α -Amylase specific activity (U/mg ⁻¹ total cell protein)		IR
	-Maltotriose	+Maltotriose	
None	1.47	5.15	3.5
Glucose	1.56	14.76	9.5
Arabinose	1.12	4.60	4.1
Fructose	0.70	4.50	6.4
Mannitol	0.47	0.48	1.0
Glycerol	1.25	6.30	5.0

Pregerminated spores of CUB74 were used to inoculate 100ml aliquots of NMMP which were supplemented with different carbon sources (to 1%). Each culture was grown for 16h and then divided into 2x50ml aliquots, each of which was supplemented with the same carbon source. Maltotriose was added to one of them and growth was allowed for a further 2h. A 1ml sample was removed from each culture and assayed for total cell protein as described in Section 2.25 and for amylase activity as described in Section 2.24.2.

IR (Induction ratio) = specific activity 2h after supplementation
with carbon source plus inducer/specific
activity 2h after supplementation with carbon
source.

CHAPTER SIX NUCLEOTIDE SEQUENCE AND CHARACTERIZATION OF *S.*

THERMOVIOLACEUS (CUB74) α -AMYLASE GENE

The α -amylase gene of CUB74, previously cloned and expressed in *E. coli* and *S. lividans* and localized on a 1.7kb *Bam*HI/*Sph*I fragment (Chapters Three and Five), was sequenced using the dideoxy chain termination method. Northern blotting and S₁ mapping experiments were carried out to determine the size of the amylase transcript and the transcriptional start site.

6.1 Results of preparing single-stranded DNA templates

Several DNA clones were generated by shot-gun cloning in M13. The 1.7kb *Bam*HI/*Sph*I fragment extracted from pQR307 (see Chapter Three for map of pQR307) was digested separately with *Sau*3A and *Taq*I and the resulting DNA fragments obtained from each digestion were cloned in the relevant restriction enzyme site in M13mp19 (that is *Bam*HI for *Sau*3A fragments and *Acc*I for *Taq*I fragments). The *Sau*3A and *Taq*I clones were selected for as described in Section 2.17.1. Single-stranded DNA templates were prepared from recombinant M13mp19 plaques (58 *Sau*3A and 66 *Taq*I plaques) as described in Section 2.17.2. Additional *Sau*3A and *Taq*I clones derived from the 1kb *Sma*I/*Sph*I fragment that was isolated from pQR307 were generated in M13mp18. Single-stranded DNA templates were prepared from 71 *Sau*3A and 16 *Taq*I recombinant M13mp18 plaques. Prior to sequencing, all single-stranded DNA templates were checked on agarose gels and an example of this is shown in Fig.6.1.

Fig.6.1. An example of analysis of single-stranded DNA templates on an agarose gel. 2µl of each ssDNA template prepared from M13mp18 or M13mp19 recombinant plaques was mixed with 5µl stop mix and loaded onto a 1% (w/v) agarose gel and electrophoresed as described in Chapter Two. The numbers refer to different plaques analysed in this experiment.

1 2 3 4 5 6 7 8 9 10 11 12 13 14 15 16 17 18

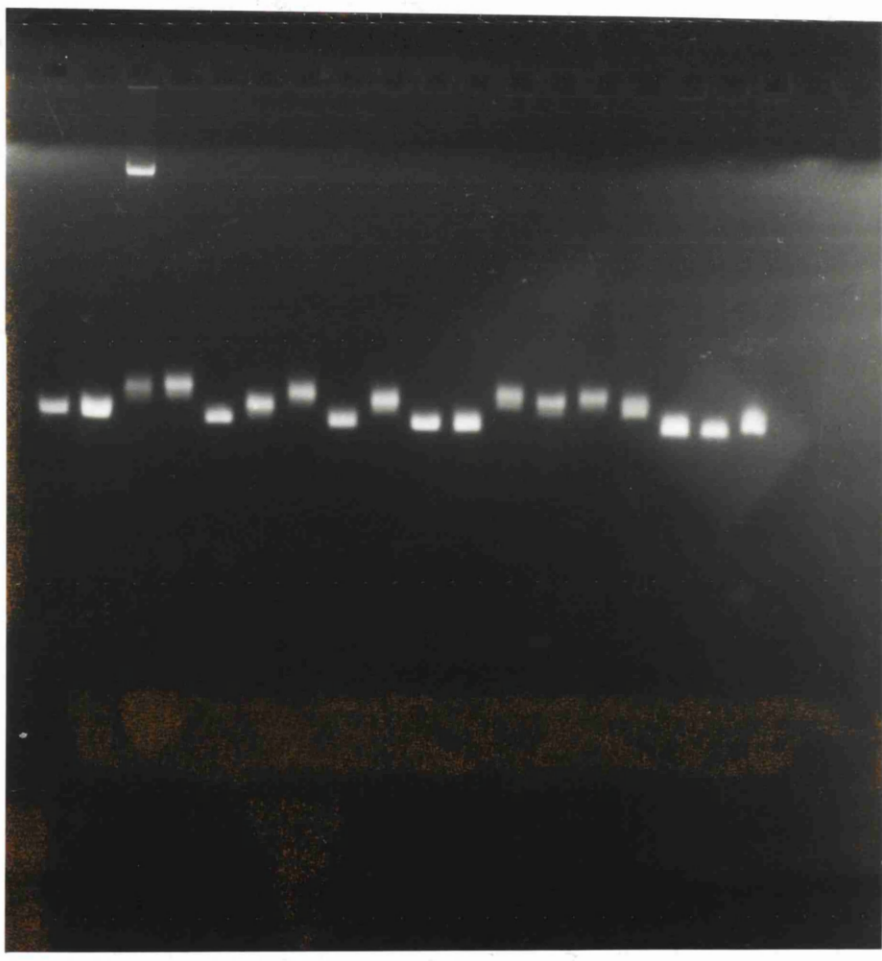

6.2 Results of preparing double-stranded DNA templates

Double-stranded DNA templates were prepared from some of the recombinant M13mp18 clones (7 *TaqI* and 4 *Sau3A* clones) described in Section 6.1. Plasmids pQR307, 312, and 314 (see Chapter Three for maps of these plasmids), were also used as double-stranded templates for sequencing. In addition, three other plasmids were constructed and used for the same purpose (Fig.6.2). These plasmids are pQR315 (constructed by cutting pQR313 with *SmaI* and religating the largest DNA fragment that contained pUC18 plus a 0.45kb insert), pQR321 (constructed by cutting pQR307 with *BamHI/NotI*, blunt-ending using the Klenow fragment of DNA polymerase I and religating the largest DNA fragment that contained pUC18 plus a 1.45kb insert), and pQR324 (constructed by cutting pQR307 with *NotI/SphI*, blunt-ending using DNA polymerase I and religating the largest DNA fragment that contained pUC18 plus a 0.25kb insert) (Fig.6.2). pQR307 was used to sequence both ends of the 1.7kb *BamHI/SphI* insert, while pQR312 and 314 were used to sequence towards the *SphI* site from the *HindIII* and the *SmaI* sites respectively. pQR315 was used to sequence from the *SmaI* site towards the *BamHI* site, while pQR321 and 324 were used to sequence from the *NotI* site towards the *SphI* and the *BamHI* sites respectively.

In order to sequence progressively further into the 1.7kb *BamHI/SphI* fragment, a time course nested-deletions experiment was also performed using a Pharmacia kit (no. 27-1691-01). In this experiment, 3 μ g pQR307 was cut with *KpnI/BamHI* and processed as described in the instructions booklet obtained from Pharmacia. *KpnI* was used to provide a 3' overhang end which cannot be attacked during the deletion reaction with exonuclease III (*ExoIII*). The deletion reaction would only take

Fig.6.2. Construction of plasmids pQR315, 321, and 324. pQR315 was constructed by removing a 1.1kb *Sma*I fragment from pQR313 (Fig.3.8). pQR321 was constructed by removing a 0.25kb *Bam*HI-*Not*I fragment from pQR307 (Fig.3.7). pQR324 was constructed by removing a 1.45kb *Not*I-*Sph*I fragment from pQR307 (Fig.3.7). All abbreviations are as described in the legends of Fig.3.5 and Fig.3.7.

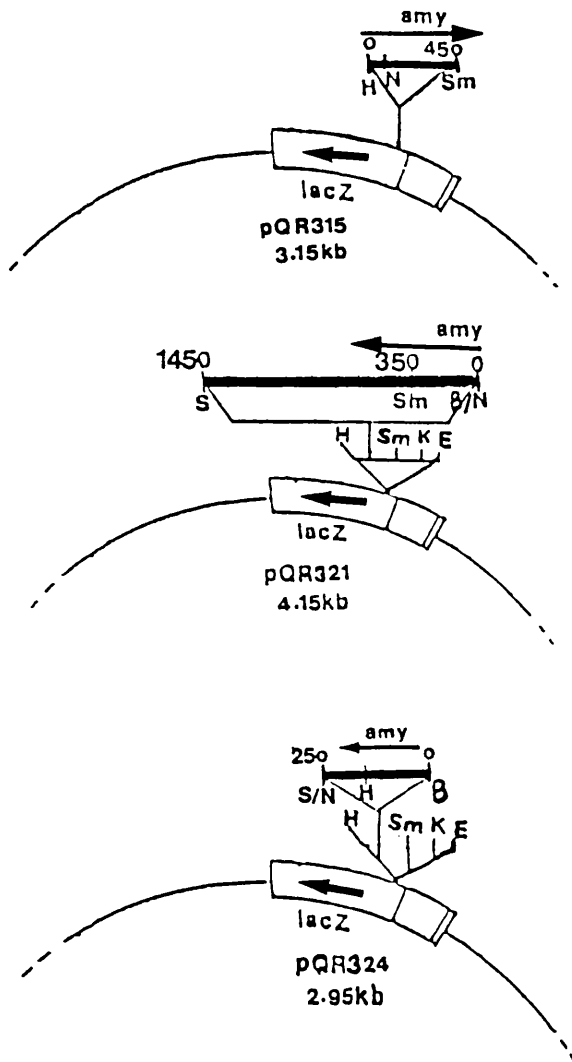

place from a 3' recessed end (provided by *Bam*HI in this case). DNA aliquots (6 μ l) were removed at time intervals (0 (control), 5, 10, 15, 20, 30, 35min) and one half of each timed sample was checked on a 1% (w/v) agarose gel (Fig.6.3). The other half of each timed DNA sample was blunt-ended by treating with S₁ nuclease to remove single-stranded regions generated by *Exo*III and ligated as described by the supplier (Pharmacia). They were introduced into competent *E. coli* and transformants were selected for on ampicillin plates. In Fig.6.3, two distinct size populations of deleted DNA were observed in each timed sample. This could have been due to incomplete digestion of pQR307 with *Kpn*I in which case *Exo*III would have digested the linear DNA from both ends and lead to the formation of the smaller of the two DNA populations. The relatively larger DNA populations were the expected fragments which became progressively smaller in size with time compared to the size of the control (0h) (Fig.6.3).

Plasmids (double-stranded DNA templates) were prepared from 16 colonies, checked on an agarose gel and sequenced. The sequencing results of these templates are shown in Table 6.1. From the 10min-sample (in the time course nested-deletions experiment), two constructs were obtained, one starts at nucleotide (nt) position 424 and the other at 553. A 20min-construct starts at nt position 871, a 25min-construct at 1100, a 30min-construct at 1486, and four 35min-constructs at 1475, 1514, 1574, and 1572.

6.3 DNA sequence analysis of α -amylase gene

The nucleotide sequence of the 1.7kb *Bam*HI/*Sph*I fragment carrying the amylase gene was completed. It is shown in Fig.6.4. The base composition of the amylase coding sequence is 69% mol G+C (Table 6.2),

Fig.6.3. Results of nested-deletions experiment. 1: λ PstI markers; 2: 0min (control); 3: 5min; 4: 10min; 5: 10min; 6: 15min; 7: 20min; 8: 25min; 9: 30min; 10: 35min.

1 2 3 4 5 6 7 8 9 10

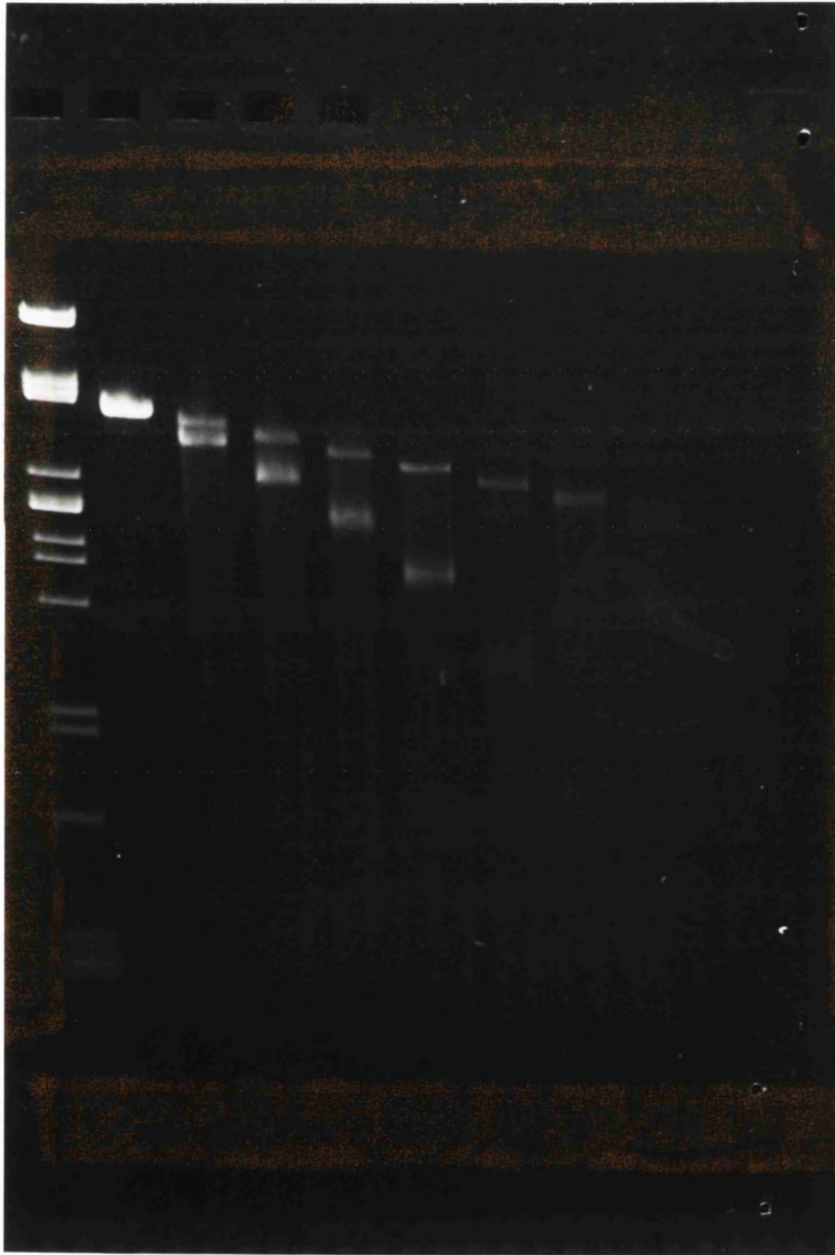

Table 6.1 Mapping of nested-deleted DNA

Time (min)	Number of colonies analysed	nt number
10	2	553, 424
20	1	871
25	1	1100
30	1	1486
35	4	1475, 1514, 1547, 1572

Table 6.2 Composition of the α -amylase codon sequence

Nucleotide combination	number per sequence	%
A	302	17.7
C	656	38.4
G	524	30.7
T	227	13.3
AA	44	2.6
AC	153	9.0
AG	72	4.2
AT	33	1.9
CA	118	6.9
CC	210	12.3
CG	229	13.4
CT	98	5.7
GA	112	6.6
GC	192	11.2
GG	146	8.5
GT	74	4.3
TA	28	1.6
TC	101	5.9
TG	76	4.4
TT	22	1.3

which is very close to the *Streptomyces* DNA average G+C content (Enquist and Bradley, 1971; Benigni *et al.*, 1975). This high G+C content results in an extremely biased usage of synonymous codons (Table 6.3), with more than 91% of the codons of amylase possessing G or C in the third position. This feature has been observed in other streptomycete genes (Hopwood *et al.*, 1986). There is also a noticeable preference for third position C over G when synonymous codons allow such a choice.

Analysis of this sequence for probable protein-coding character indicated a unique complete open reading frame (ORF) that was most likely to encode the α -amylase. It starts with an ATG (translational start codon) at nucleotide position 215 and ends with a TGA stop codon at nt 1591. This ORF could encode a protein of 460 amino acids (aa) with an estimated size of 49.225 kDa.

Situated 8bp upstream of the presumptive translational start codon is the sequence 5'-GAAAGA-3' (Fig.6.5), which shows perfect complementarity to the sequence of the 3' end of 16S rRNA of *S. lividans* (Bibb and Cohen, 1982). This sequence is likely to be the ribosome-binding site of the α -amylase. Comparison of the presumptive promoter sequences of the α -amylase genes of *S. thermoviolaceus* and *S. limosus* revealed perfectly homologous -10 (5'-TACGGT-3') and -35 (5'-TTGACC-3') regions (Fig.6.5). The distance between the presumed -10 and -35 regions in both streptomycetes is 17bp which is the optimum distance in eubacterial promoters.

6.4 Amino-terminal sequence of CUB74 α -amylase

The deduced aa sequence of this ORF is highly similar to the α -amylase of *S. limosus* (Long *et al.*, 1987) (Fig.6.6). However, the *S.*

BamHI 10 20 30 40 50 60 70 80
 GATCCGGGACGGATCGTGCCCGCACACCCCTGCCGGCTGCACTGCACCATGAACCTTCATGGTCTCTGACAGGTT

*

90 -35 110 -10 130 140 **HindIII** 160
 CATGTCACAGATTGACCGCCCGCAACGGCGCTCGTACGGTCCGGTGCACGTCGCGAGCGCTGAAAGCTTGCAGCAAGTT

170 180 190 200 210 220 230 240
 CTTCCATCCCCTTGTCCGTCGACGGACCTCCGACGGAGAAAGAACCCACATGGCCAGCAGAACGCTCTCGGGCC

M A S R T L S G A

250 **NotI** 260 270 280 290 300 310 320
 GCTCGCCCTGGCGCCGCGGACGGGTCTCGCCGCTCCCGCCATCGTGGCCACGGCTCCCGCCCGGACAGGCGT

L A L A A A A T A S S P L P P S S P T A F R P A Q A

330 340 350 360 370 380 390 400
 CACGGCTCTTTCGAGTGGACTACGGCTCCGTGGCCAAAGGAGTGCACAGCACCTCGGCCCGGGCTACGGCTAC

S R V L F E W D Y A S V A K E C T S T L G P A G Y G Y

410 420 430 440 450 460 470 480
 GTGCAGGTCCTCCCGCCCGGACACATCCAGGGCTCCAGTGGTGCACGTCGTACACAGCGGTGAGCTACAAGATCGC

V Q V S P P A E H I Q G S Q W W T S Y Q P V S Y K I A

490 500 510 520 530 540 550 560
 CGGCGGCTCGGGACCGTCCCGCTTCGGATCCATGGTGAACACCTGCCACCGCCGGGGTGAAGGTGGTCTCGACA

G R L G D R A A F R S M V N T C H A A G V K V V V D

570 580 590 600 610 620 630 **SmaI** 640
 CGGTGATCAACCATGTCCGGCCCGGACGGCCACGGCAGCGAGGCTCGGGTACACGAAGTACGACTACCCGGGGCT

T V I N H M S A G S G T R H R R L G V H E V R L P G A

650 660 670 680 690 700 710 720
 GTACTCGGCCCGGACTTCGACGACTGCACCGGAGATCACCGACTACAGGACCGTGGAACGTCACGACTGCGAACT

V L G P G L R R L H R E I T D Y Q D R W N V Q H C E L

730 740 750 760 770 780 790 800
 GGTGGGCTCGCGACCTGCACCGGTGAGGAGTACGTGCGACAGAGATCGCCGGTACATGAACGACCTGCTCTCC

V G L A D L D T G E E Y V R Q T I A G Y M N D L L S

810 820 830 840 850 860 870 880
 TCGGCGTCGACGGCTTCGGCATCGACCGGGCCACGCACATCCCGCCGAGGACCTCGCGAACATCAAGTCCCGCTGAGC

L G V D G F R I D A A T H I P A E D L A N I K S R L S

890 900 910 920 930 940 950 960
 AACCCGAACCGCTACTGGAAGCAGGAGGTCTACTCGGCCCGGGAACCTCCCAAGCCCGGAGTACACCGGCACCGG

N P N A Y W K Q E V I Y G A G E F F K P G E Y T G T G

970 980 990 1000 1010 1020 1030 1040
 CGACGTCACGAGTTCCTACGCCTACGACCTCGAAGCGGGTCTTCAACAGGAGCACCTCGCCTACCTGAAGAATACG

D V Q E F P T P T T S K R V F T Q E H L A Y L K N Y

1050 1060 1070 1080 1090 1100 1110 1120
 GCGAGGACTGGGGCTACCTGAGCAGCAGCAGCGCCGGGCTCTTCGTCGACAACCACGACACCGAGCGCAACGGCTCCAGC

G E D W G Y L S S T T A G V F V D N H D T E R N G S T

1130 1140 1150 1160 1170 1180 1190 1200
 CTGAACACAGAACGACGCCACCTACACCTGGCCACGCTTTCATGCTGGCTTGGCCCTACGGCCCGCCGACATCAA

L N Y K N D A T Y T L A N V F M L A W P Y G A P D I N

1210 1220 1230 1240 1250 1260 1270 1280
 TTCGGCTACGAGTGGTCCGACCCCGGACCGCCCGCCCGGACCGGCGCCACGTCGACGCTGCTGGCAGAACGGCTGGAA

S G Y E W S D P D A G K P T A A T S T P A G R T A G

1290 1300 1310 1320 1330 1340 1350 1360
 GTGCCAGCACAAGTGGCCGAGATCGATCGCTCCATGGTCCGCTTCGCAACGCCACCCCGGAGCGCGGTACCGGAC

S A S T S G P R S I A S M V A F R N A T R G E P V T D

1370 1380 1390 1400 1410 1420 1430 1440
 TGGTGGGACGACGGCGGACGCCATCGCCTTCGGCCGGGGCAGCAAGGGCTTCGTGGCCATCAACCACGAGTCCGCCAC

W W D D G A D A I A F G R G S K G F V A I H H E S A T

1450 1460 1470 1480 1490 1500 1510 1520
 CGTCCAGCCACCTACAGACTCCCTGCCCCGGCACCTACTGGGAGGTGCAGAGCAACACACGGTGACGGTGGACT

V Q R T Y Q T S L P A G T Y C D V Q S H T T V T V D

1530 1540 1550 1560 1570 1580 1590 1600
 CCGCCGACGGTTCACCGCCCGCTCGGCCCGGACACGGCACTGGCCCTGCACAACGGCAGGACGAGCTGCTGACCGTCC

S A G R F T A A L G P D T A L A L H N G R T S C *

1610 1620 1630 1640 1650 1660 1670 1680
 GCGGCGATTACCCGGACGGGCCACCGTGGTGGCCGAGCGGTGGCTGGCTCCGGCGTGGCGGTGGCCCGGAC

1690 1700 **SphI**
 GCGGACCGAGCGGAGCAATCGGGCATGC

Fig.6.4. Nucleotide sequence of the α -amylase gene (*amy*). The start of transcription is indicated by open circles and the associated arrow indicates the direction of transcription. Putative -10 and -35 regions are overscored and the probable signal peptidase cleavage site is indicated by an upward arrow. Converged arrows indicate inverted repeats. The potential ribosome binding site (RBS) is overscored and the translation stop codons are indicated by asterisks.

thermoviolaceus α -amylase is much shorter and differs at the C-terminus. A putative signal sequence of 28aa of the form Met-Ala-Ser-Arg-Thr-Leu-Ser-Gly-Ala-Leu-Ala-Leu-Ala-Ala-Ala-Ala-Thr-Ala-Ser-Ser-Pro-Leu-Pro-Pro-Ser-Ser-Pro-Thr occurs at the N-terminus of the predicted sequence (Fig.6.4). Comparison of this region with the N-terminus of the extracellular form of *S. limosus* α -amylase suggests that cleavage occurs after the Ser-Pro-Thr triplet (Fig.6.6). Cleavage of the signal peptide would yield a mature protein of 431aa with a molecular weight of 47kDa, which is in good agreement with the size of the enzyme estimated from SDS-PAGE (50kDa) (see Chapters Three and Five).

6.5 Comparison between the amino acid sequence of *S. thermoviolaceus*

***CUB74* α -amylase and those of other streptomycete α -amylases**

Fig.6.6 shows an optimal alignment of the deduced aa sequences of α -amylases of *S. thermoviolaceus*, *S. limosus*, *S. venezuelae* and *S. hygroscopicus*. These proteins are homologous i.e. derived from a common ancestral gene, with the *S. thermoviolaceus* and *S. limosus* enzymes showing the greater degree of similarity (i.e. 63.6%) compared to 62.5% for CUB74 and *S. venezuelae*, and 55.1% for CUB74 and *S. hygroscopicus* (Table 6.4). The sequence Phe-Glu-Trp which has been suggested as a possible candidate for interaction with the inhibitor tendamistat (Hofmann *et al.* 1985) is present in *S. thermoviolaceus*, *S. limosus* and *S. venezuelae* sequences at aa position 44-46 (Fig.6.6); the Trp residue of this triplet is replaced by Arg in the *S. hygroscopicus* α -amylase (Fig.6.6).

The four highly conserved regions previously reported for other α -amylases (Nakajima *et al.*, 1986; Rogers, 1985) could be observed in

Table 6.3 Distribution of codons in the CUB74 α -amylase open reading frame

Codon	AA	Usage	Codon	AA	Usage	Codon	AA	Usage	Codon	AA	Usage
TTT	Phe	0	TAT	Tyr	0	TCT	Ser	0	TGT	Cys	0
TTC	Phe	11	TAC	Tyr	20	TCC	Ser	14	TGC	Cys	5
TTA	Leu	0	TAA	End	0	TCA	Ser	1	TGA	End	1
TTG	Leu	0	TAG	End	0	TCG	Ser	9	TGG	Trp	10
CTT	Leu	1	CAT	His	0	CCT	Pro	4	CGT	Arg	1
CTC	Leu	15	CAC	His	12	CCC	Pro	11	CGC	Arg	11
CTA	Leu	1	CAA	Gln	0	CCA	Pro	1	CGA	Arg	5
CTG	Leu	13	CAG	Gln	14	CCG	Pro	12	CGG	Arg	6
ATT	Ile	0	AAT	Asn	1	ACT	Thr	0	AGT	Ser	2
ATC	Ile	13	AAC	Asn	17	ACC	Thr	20	AGC	Ser	11
ATA	Ile	0	AAA	Lys	0	ACA	Thr	1	AGA	Arg	5
ATG	Met	6	AAG	Lys	10	ACG	Thr	21	AGG	Arg	6
GTT	Val	0	GAT	Asp	0	GCT	Ala	5	GGT	Gly	1
GTC	Val	15	GAC	Asp	26	GCC	Ala	39	GGC	Gly	36
GTA	Val	3	GAA	Glu	3	GCA	Ala	2	GGA	Gly	3
GTG	Val	13	GAG	Glu	16	GCG	Ala	10	GGG	Gly	3

The codons represent 459 amino acids with a molecular weight of 49.225kDa. AA: amino acid.

Fig.6.5. Comparison between the promoter sequence of *S. thermoviolaceus* amylase gene (stt) and those of *S. limosus* (stl) and *S. venezuelae* (stv). Putative -10 and -35 regions are overscored and the start of transcription is indicated by dots (see Section 6.8). The direction of transcription is 5' to 3'. The ribosome binding site (RBS) is underlined and the translational start codon is indicated by fM (f-Methionine).

```

stt 5' GAACCCTTCATGGTCTCTGACAGGTTTCAT      GTCCAGAGTATTGACCGCCCGCAACG GCGCTC
stl   GA TGTCCGTGGTGTTT CGGGTTTCGT      GTCCAAAGGGTTGACCGCGGGTACCGCTCGCTC
stv   TA ACAACTTGC GTTGT GGGGTTTCGCGGGGGCGTCCGGAGGGTTGACCGCGGGTCGGGGCACTCG

stt   GTACGGTCGGCTGCACGTGCGAGCGCTGAAAGCTTGCAGCAAGTTCT TCCATCCGCTTGTCGGTCCG
stl   TACGGTCTGCTTCGGGACGC TCCTTGCAGTTTTGCTGCAAGAGAAATTCAGCCCTCCGCCCCCCC
stv   TACGGTCACGGCTGAAAACA GTTGCTGACATTTTCAGCAACTTCTTTGCGACAGTGAAGTC

stt   ACGCGACCCTCCGAGAAAGAACCCCCACATG-3'
stl   CGATCAGGAGGCACCACATG
stv   AGCAGGAGGAATC ATG
      RBS

```

Fig.6.6. Optimal alignment of the amino acid sequence of four streptomycete α -amylases. sth: *S. hygroscopicus*; other abbreviations are as described in the legend of Fig.6.5. Highly conserved regions in the four streptomycete enzymes are underlined and the four previously recognized conserved regions in α -amylases are overscored. Based on data by Long *et al.* (1987), residues involved in substrate binding are indicated by triangles. Based on homology data to porcine pancreatic α -amylase (Fig.6.7), residues involved in calcium binding are indicated by dots and those involved in catalysis by open circles. Asterisks indicate residues involved in binding to inhibitor and downward arrow indicates the probable signal peptidase cleavage site which was determined only in *S. limosus* enzyme. This alignment was performed according to the MicroGenie computer program.

```

          ↓
stt ...MASRTLoSG ALAL.AAAAT ASSPLPPSSP TAPRPA.QAS RVLFEWoDYAS VAKECTSTLoG 60
stv ...MARKTVAA ALALVAGAoAV A.VTGNAPAQ AVPPGEKDVoT AVoMFoEWoNFAS VARECTDRLG
stl ...MARRLATA SLAVLAAAAT A.LTAPToPAA AAPPoGAKDVoT AVoLFoEWoKFAS VARACTDSLoG
sth MQQRSRVLGG TLAGIVAAAA A.TVAPWPSQ ATPPGQKToVT AToLFoERoKYVD VAKACTDQLoG

stt PAGYGYVQVS PPAEHIQGSQ WoWTSYQoPVSY KIAGRLGDRA AFRSMVNTCH AAGVKVVVDoT 120
stv PAGYGVVQVS PPQEHoLQGGQ WoWTSYOPVSY KIAGRLGDRT AFKNMIDTCH AAGVKVVADS
stl PAGYGYVQVS PPQEHoLQGSQ WoWTSYOPVSY KIAGRLGDRA AFKSMVDoTCH AAGVKVVADS
sth PAGYGYVEVS PASEHIQGGQ WoWTSYOPVSY KIAGRLGDoRD AFASoMVoSACH AAGVKVIADA

stt VoINoHMSAGSG TRHRRoLGoVHE VRLPGAVLGP GLRRLHREIT DoYoQDRWoNVQH CELVGLADLD 180
stv VINHMANGSG TGTGGTSPoSK YDYPGIWoSGA DMDDCRSEIN DYGNRANVQoN CELVQLPDLoD
stl VINHMAAGSG TGTGGSAYQK YDYPGIWoSGA DMDDCRSEIN DYGNRANVQoN CELVGLADLD
sth VoVNHMAAGSG RHHAQ.oYTK YNYPGFYQDQ TFHGCRKoSIS DYTNRDDVQT CELVDLADLG

stt TGEoEYVRQTI AGYoMNDLLSL GVDGFRIDAA THIPAEDLAN IKSRLSNPNA YWKQoEVIYGA 240
stv TGEDHVRGKI AGYLNDLoASL GVDGFRIDAA KHMPAADLAN IKSRLTNPV FWKLEAIHGA
stl TGESYVRDRI AAYLNDLLSL GVDGFRIDAA KHMPAADLTA IKAKVNGST YWKQoEAIHGA
sth TGSoDYVRTTI AGYL.GLRSL GVDGFRIDAA KHISATDLAA VKGKMKDPG. FoWoVQoEVIYGA

stt GEPoPKPGEYT GTGDVQEFPT PTTSKRVFTQ EHLAYLKNYG EDWGYLSSTT AGVFVDNHDoT 300
stv GEAVSPSEYL GSGDVQEFoRY ARDLKRVLQG EKLSYLKNFG EAWGHMPoSGQ SGVFVDNHDoT
stl GEAVQPSoEYL GTGDVQEFoRY ARDLKRVFQM ENLAHLKNFG EDWGYMASGK SAVFVDNHDoT
sth GEAVRPDEYT GIGDVDEFoRY GTHLKSoAFQS GNIAQLKoSVA D.oGKLWoQRQ ARTFVDNWDoT

stt ERNGSTLNYK NDATYTLANV FoMLAWPYGAP DINSoGYEWSoD PDAGRPTAAT STPAGRTAGS 360
stv ERGGDTLSYK DGANYTLASV FoMLAWPYGSP DVHSGYEWTD XDAG.PPNNG QVNACYTDGoW
stl ERGGDTLNYK NGSAYTLAGV FoMLAWPYGSP DVHSGYEFoTD HDAG.PPNNG TVNACYSDGoW
sth ERNGSTLTYK DGAAoYTLANV FoMLASPYGSP NVYSoGYEWDoT KDAoA.AGG... STGoW

stt ASTSGPRoSIA SMVAFRNATR GEPVTDWoWDD GADAIAFGRG SKGFVAINHE .SATVQRTYQ 420
stv KCQHAWREIS SMVAFRNoTAR GQAVTNWoWDN GNNAIAFGRG SKAYVAINHE TSA.LTRTFQ
stl KCQHAWPELS SMCGLRNTAS GQPVTNoWoWDN GGDQIAFGRG DKAYVAINHE GSA LNRoTFQ
sth TDDAAKREIT GMVGFoRNAVoG SAELoTNoWoWDN GGRPLAFARS DKGFVALNNG DAA.LTQTFA

stt TSLPAGTYCD VQSNTToVTVD SAGRFTA.oA .LGPDTALAL HNGRTSC 480
stv TSLPAGSYCD VQSNToPVTVN SSGQFTAT.o .LAANTAVoAL HVNATGCGST PTPPTToPPA
stl SGLPGGAYCD VQSGRSVTVG SDGTFoTAT.o .VAAGTALAL HTGARTCSGG GTGPGT...G
sth TSLPAGTYCD VVHAASSCDG DTVTVGDTEA QVDAAKSVAL HVGATGQSAC RQAVALHVPoG

stv TSGASFNVTA TTVVQoNIYV TGNRAELGNW APASALKLDP ATYPVWKLTV GLPAGTSFoEY 540
stl QTSASFHVNA TTAGWENIYV TGDQAALGNW DPARALKLDP AAYPVWKLoLV PLAAGTPFQY
sth QSAGSPRSSA KRVEQ

stv KYIRKDAAGN VTWESGANRT ATVPASGQLV LNDTFRS 577
stl KYLRKDAAGK AVWESGANRT ATVGTTCALT LNDTWRG

```

the streptomycete sequences at aa position 119-124 (region 1), 202-212 (region 2), 235-238 (region 3) and 294-300 (region 4) (Fig.6.6). The alignment also revealed additional blocks of aa that are present in all four streptomycete enzymes at aa positions 59-67, 80-99, 109-116 and 385-391 (Fig.6.6). The fourth sequence is less conserved in comparison with the other three sequences.

Previous work based on comparison between *S. limosus* and *Aspergillus oryzae* α -amylases (Long *et al.*, 1987) indicated that the highly conserved residues in fungal α -amylases Ile-152, Tyr-155, Val-161, Thr-170 (Leu in st1), Leu-173, and Asp-175 lie on one side of the proposed cleft where the amylose chain fits, while Tyr-82, Gln-84, and Thr-85 (Pro in st1) lie on the other side and would be directly juxtaposed to the amylose chain, suggesting that these residues play important roles in substrate binding. These residues are also highly conserved in the four streptomycete α -amylase sequences (Tyr-85, Gln-86, Pro-87, Ile-159, Tyr-162, Val-168, Leu-173, Leu-176, and Asp-178) and therefore could be involved in substrate binding (Fig.6.6).

6.6 Comparison between extracellular forms of the *S. thermoviolaceus* and the porcine pancreatic α -amylases

The degree of aa sequence identity between CUB74 α -amylase and the other α -amylases was determined and is shown in Table 6.4. A remarkable degree of aa sequence identity (44.3%) is found between the extracellular forms of CUB74 (stt) and porcine pancreas (ppa) α -amylases. An optimal alignment between the two enzymes is shown in Fig.6.7. The three dimensional structure of ppa has been determined (Buisson *et al.*, 1987) and the residues involved in Ca⁺⁺ binding were shown to be Asn-100, Asp-159, Asp-167 and His-200 (numbering is as

Table 6.4 Amino acid sequence identity between CUB74 and some other known α -amylases

Amylase	Amino acid sequence length	% Identity
stt	459	100
stl	566	63.6
stv	568	62.5
sth	478	55.1
ppa	496	44.3

$$\% \text{ Identity} = \frac{\text{no of identical residues per comparison}}{\text{no of residues in the shorter sequence}} \times 100$$

shown in Fig.6.7). In CUB74 α -amylase sequence, these residues also occur and match those of ppa except Asp in ppa corresponds to His-159 in CUB74 (Fig.6.7). The same residues also occur in stl, stv, and sth at matching positions to those of CUB74 except His-159 (position 170 in Fig.6.6) in CUB74 corresponds to Asn in stl and stv, and Thr in sth (Fig.6.6). It would be of interest to test if Ca^{++} would influence the activity of these three mesophilic enzymes.

6.7 Results of Northern blotting

The size of the transcript produced by the amylase gene was determined by carrying out a Northern blotting experiment as described in Section 2.15. Total mRNA samples prepared from different *Streptomyces* cultures (Section 2.14) were analysed on an agarose gel, which contained formamide and formaldehyde, alongside RNA size markers (Fig.6.8). The gel was then blotted as described in Section 2.15. The DNA probe used in this experiment was a 1.5kb *Hind*III-*Sph*I DNA fragment that had been extracted from pQR307 (see Chapter Three for map of pQR307) and nick-translated in the presence of (α - ^{32}P)dCTP as described in Section 2.11. The results of this experiment are shown in Fig.6.8. In the *S. lividans* pQR311 lane, the probe hybridized to three mRNA bands of different sizes, 1.5, 2, and 3kb. The smallest band (1.5kb) is presumably a result of transcription from the promoter of the gene whereas the other two bands may have resulted from readthrough from other promoters situated on the vector pIJ702 (see Section 6.8). No RNA bands were detected in the control *S. lividans* pIJ702.

In the *S. lividans* pQR318 (see Chapter Five for map of pQR318) lane, the probe hybridized to one RNA band only (Fig.6.8). The size of this

Fig.6.7 Comparison between the extracellular forms of the *S. thermoviolaceus* (stt) and pig pancreatic (ppa) α -amylases. Residues involved in calcium binding are indicated by dots and those involved in substrate binding by open triangles. Residues involved in catalysis are indicated by filled triangles. The functions of these residues have been determined by Buisson *et al.* (1987) for the mammalian α -amylase. Con: conserved residues found in both sequences.

```

stt  APRP.AQASR...V LFEWDYASVAKECTSTLGPAGYGYVQVSPPAE...HIQGS.Q△△△W△△TSYQPVSYKIA 70
ppa  QYAPQTQSGR△TDIVHLFEWRVVDIALECYRLGPKGFGGVQVSP△PNENVVVTNPSRP△W△WERYQPVSYKLC
con   P  Q  R  V LFEW    A EC  LGP G G VQVSP△ E    S  W△W  YQPVSYK

stt  GRLGDRAAFRSMVNTCHAAGVKVVVD△TVINHM...S...AGSGTRHRRRLGVHEVRLPGAV.....LGPG.L 141
ppa  TRSGNENEF△RD△MVTRC△NNVGVRIYVDAVINHMCGSGAAAGTGTTCG△SYCNPGNREFPAVPYSAWDFNDGKC
con   R  G    FR MV  C  GV  VD VINHM S  AG GT          R  AV          G

stt  RRLHREITDYQDRW△VN△HN△C△ELVGLADLD△TGEEYVRQT△IAGY△MNDLLSLGVDGFRIDAATHIPAEDLANIKS 211
ppa  KTASGGIESYNDPYQVRDCQLVGLLDL△ALEKDYV△RS△HIADYLNK△LIDIGVAGFR△LDASKHMWPGDIKAVLD
con   I  Y  D  V  C  LVGL DL    YVR  IA  Y  N  L  GV  GFR  DA  H  D

stt  RLSNPAYW.....K△Q△E△V△I△YGAGEPPK△PGEY△TGTGDVQEF...PTPTTSKR△VFTQEHLAYLK△NYGED 281
ppa  KLHNLNTNWF△PAGSR△PFIFQ△EV△IDLGGEA△IKSGEY△FSNGRVTEFKY△GAKLGT△VVRK△WSGEK△MSYLK△NWGE△G
con  L  N  N  W    Q△E△V△I  GE  K  GEY  G  V  EF    T  R    E  YLKN  GE

stt  WGYLSSTTAGVFVDN△H△D△TER...NGSTL△NYKNDATYTL•ANVFMLAWPYGAPD△INSGYEW.....SD. 351
ppa  WGFMP△SDRALVFVDN△H△DN△QRGHGAGGSSILTFWDAYRKLVA△VGFM△LAHPYGFTRV△MSSYRWARNFVNGEDV
con  WG  S  A  VFVDN△H△DN△QR    GS    DA  LA  FMLA  PYG    S  Y  W    D

stt  PD AGRP....TAATST PAGRTAG•SASTSGPRSIAS△MVAFRNATRGE△PVTD△WWDGADAIAFGRGSKG 421
ppa  NDWIGPPN△NGVIKEVTINADTT△CGNDWVCEHRWREIR△NMVWFRNVVDGEPFAN△WWDNGSNQVAFGRGRNG
con   G  P          T  A  T  G          R  I  MV  FRN  GEP  WWD  G  AFGRG  G

stt  FVAINHESATVQRTYQTS△LPAGTYCDVQ△SNTT△VTVDSAG△RFTAALGPDTALALHNGRTSC 491
ppa  FIVFNDDWQLSSTLQ△TGLPAGTYCDV△ISGDKV  GNSCTG△IKVYVSSD  GKAQFSISNSAEDPFIAIHAES
con  F  N          T  QT  LPAGTYCDV  S  V  S          D  A  S

ppa  KL

```

Fig.6.8 Northern blotting. a) Analysis of RNA samples on agarose gels in the presence of formamide and formaldehyde. 1: RNA size markers in kb; 2: *S. lividans* pQR311; 3: *S. lividans* pIJ702 (control); 4: RNA size markers; 5: *S. lividans* pQR318; 6: *S. lividans* pQR1 (control). b) RNA blots that were hybridized to a nick-translated 1.5kb *Hind*III-*Sph*I fragment. The positions of RNA bands are indicated by arrows.

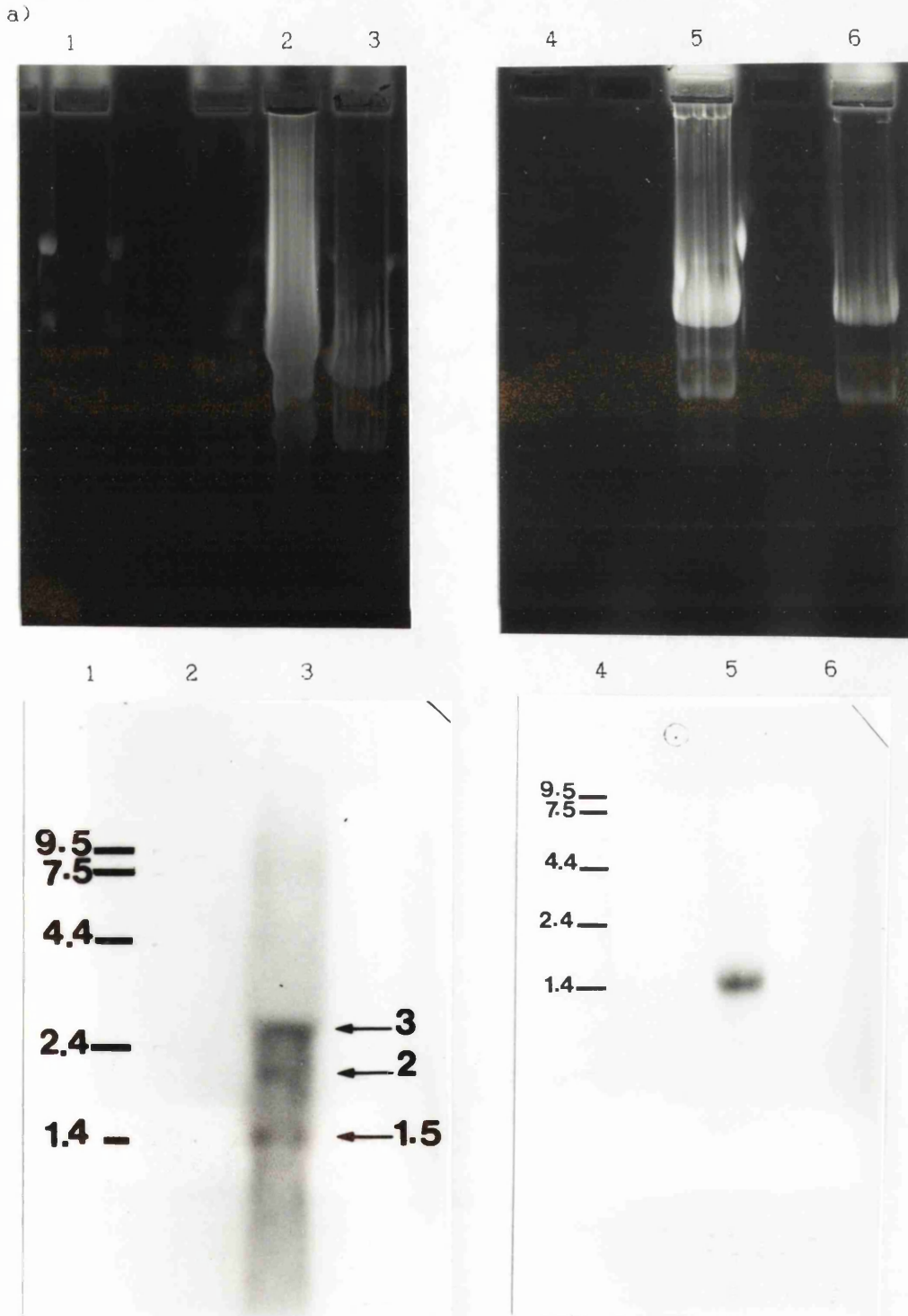

band is approximately 1.45kb which indicates that the amylase gene in pQR318 is transcribed from a promoter situated very close to the *Hind*III site. The probe did not hybridize to any RNA bands in the *S. lividans* pQR1 lane (control).

6.8 Results of high resolution *S*₁ mapping

To map the site of transcriptional initiation of the amylase gene, a 0.27kb *Not*I/*Eco*RI fragment was isolated from pQR307 and labelled at the 5' ends (as described in Section 2.11). The labelled DNA fragment was first digested with *Bam*HI to remove one of the labelled ends and then hybridized to RNA isolated from *S. lividans* pQR311, pIJ702, pQR318, and pQR1. This experiment was done as described in Section 2.16. The results are shown in Fig.6.9. The sequence of the probe cloned in pUC18 (pQR324) includes the sequence of the 17-base primer and the 10-base polylinker generated in the cloning (see Section 6.2 for constructing pQR324). The 10 bases resulted from treating pQR307, after being cut with *Not*I/*Sph*I (in the process of constructing pQR324), with DNA polymerase I. DNA polymerase I is able to fill the recessed 3' end that was generated from *Not*I activity and to chew the 3' overhang end that was generated from *Sph*I activity. Therefore, a correction of 27 bases in the 3' direction of the RNA complementary strand is necessary.

Three *S*₁-protected fragments were detected in the *S. lividans* pQR311 lane (lane 6). Correlation of the smallest of these bands and the sequence ladders revealed that this band corresponds to nucleotides GGC at position 124-126. These nucleotides are located 89-91bp upstream from the translational start codon (Fig.6.4; Fig.6.9). The largest protected band in lane 6 is the same size as the probe itself.

Fig.6.9 High resolution S₁ mapping. 1: *S. lividans* pQR318; 2 (A), 3 (T), 4 (C), and 5 (G) are the sequencing reactions of the probe that had been cloned in pUC18 (pQR324) and sequenced with the 17-base universal primer; 6: *S. lividans* pQR311; 7: *S. lividans* pIJ702 (control); 8: *S. lividans* pQR1 (control). Arrows indicate the S₁-protected mRNA bands.

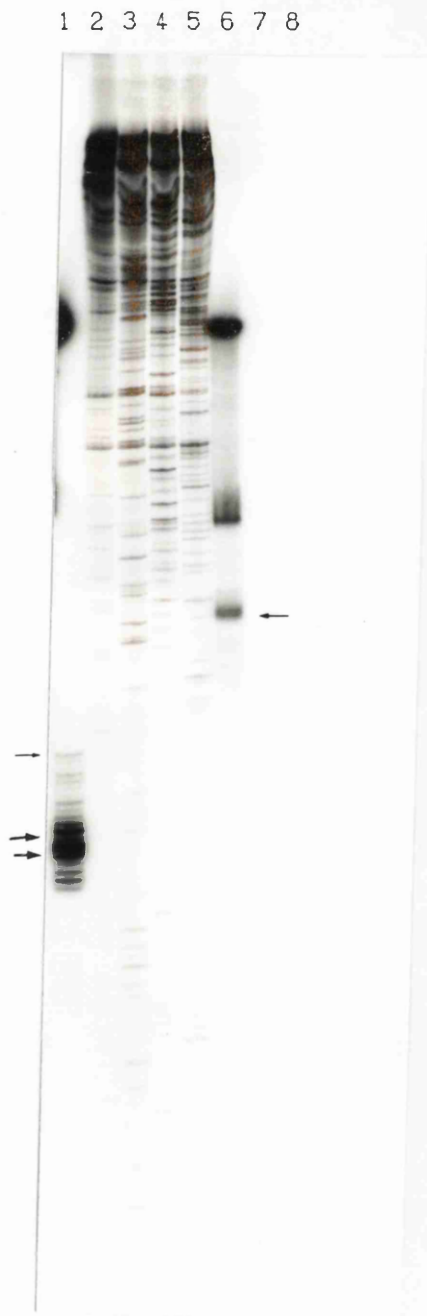

This is consistent with the results obtained in the Northern blotting experiment (Fig.6.8) and may present additional proof that readthrough from other promoters situated on the vector itself (pIJ702) might have occurred, although the possibility of reannealing of the probe cannot be ruled out. No protected RNA bands were detected in the control *S. lividans* pIJ702 in the conditions used in this experiment. 2-4bp upstream from the transcriptional start site are located potential -10 (TACGGT) and -35 (TTGACC) regions separated by 17bp (Fig.6.4). These regions may constitute the promoter of the gene as they are identical to promoter sequences found in *S. limosus* and *S. venezuelae* amylase systems (see Fig.6.5). The protected band which is approximately 35 bases higher than the band corresponding to the start of transcription might represent a transcriptional start from another promoter further upstream. It might also correspond to a transcriptional end of a message obtained from the opposite DNA strand only if the *Bam*HI digestion of the labelled *Not*I/*Eco*RI fragment was not complete.

In *S. lividans* pQR318, a scatter of protected bands were detected (Fig.6.9). In the scatter of bands, there are two or three intense bands (lane 1). These bands correspond to the nucleotides TTC 9-11 bases downstream from the *Hind*III site (see Fig.6.10). Potential -10 (AAAGCT) and -35 (TTAACT) regions of the promoter (pQR318P) were mapped within the *E. coli* part of the plasmid (Fig.6.10) and the distance between these two regions is 18bp. The topmost S₁-protected band (less intense band) in the *S. lividans* pQR318 lane might represent a transcriptional start site from another and less efficient promoter. In *S. lividans* pQR318, CUB74 α -amylase was transcribed from promoters situated on the *E. coli* part (pBR325) of pQR1 but this

Fig.6.10 Promoter sequence of pQR318P in the construct pQR318. The *Hind*III site is the junction between the vector and the CUB74 amylase gene. Downstream from this *Hind*III site is the CUB74 α -amylase sequence whereas upstream is the pBR325 sequence (part of pQR1). Potential -10 and -35 regions of pQR318P which are located in pBR325 are overscored. Open circles indicate the transcription start site as determined by high resolution S₁ mapping (Fig.6.9) and the associated arrow indicates the direction of transcription.

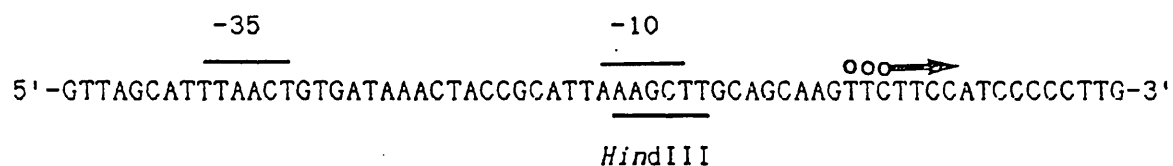

promoter is not functional in *E. coli* (see Chapter Five). There were no S₁-protected fragments in the control *S. lividans* pQR1 (lane 8).

6.9 Summary

The α -amylase gene of CUB74 was sequenced. It has a G+C content of 69% which is typical of *Streptomyces* DNA. This gene encodes a protein of 49.225kDa with a leader sequence of 28 aa at the N-terminus. The triplet Phe-Glu-Trp which is thought to be the site of interaction with tendamistat is found in the CUB74, *S. limosus*, and *S. venezuelae* α -amylase sequences.

The transcription start site of the gene was mapped and a promoter sequence identical to the *S. limosus* and *S. venezuelae* α -amylase sequences was found upstream from the translation start site (ATG). In *S. lividans* pQR311, readthrough from other promoters situated on the vector pIJ702 was also detected.

A potential promoter sequence in the *E. coli* part of pQR318 was found to be active in *S. lividans*. However, this promoter is not active in *E. coli* pQR318.

The deduced aa sequence of the CUB74 α -amylase was found to have a high degree of similarity (55-65%) to those of other streptomycete α -amylases. The mature form of the CUB74 enzyme was also found to have 44% homology to that of the pig pancreatic α -amylase.

The thermophilic *Streptomyces* species *S. thermoviolaceus* strain CUB74 was chosen for the work described in this thesis since it is a better amylase producer (i.e. it produces larger amylase zones on plates) than the two other thermophilic *Streptomyces* species *S. thermovulgaris* and *S. rectus*, which were available at the start of the project. The α -amylase of *S. thermoviolaceus* was also found to respond to induction and repression. In addition, upon the initiation of this work there had been no reports so far on cloning, sequencing and regulation of amylases from thermophilic streptomycetes.

Thermophilic *Streptomyces* were recently classified by Goodfellow *et al.* (1987). In the numerical classification, they were found to fall into three major, five minor, and two single-member clusters. *S. thermoviolaceus* species were assigned to the second major cluster whereas *S. thermovulgaris* was assigned to the first major cluster. *S. thermoviolaceus* was found to grow well on yeast/malt agar, producing plane or convolute colonies with aerial mycelium. Its growth on half-strength nutrient agar was described to be poor and the colourless colonies often lacked aerial mycelium. The thermophilic streptomycetes studied by Goodfellow *et al.* (1987) were found to produce a variety of enzymes, including amylases, proteases, lipases, and endonucleases.

The ability of *S. thermoviolaceus* CUB74 to produce different enzymes was tested by growing the organism on media supplemented with substrate. Hydrolysis zones were detected around the colonies when CUB74 was grown on skimmed milk, starch, and Tween 80.

7.1 Expression of CUB74 α -amylase in *E. coli*

An α -amylase gene isolated from *S. thermoviolaceus* CUB74 has been cloned and expressed in *E. coli*. Transformation of competent *E. coli* cells with the CUB74 DNA library made in pUC8 yielded approximately 10000 Ap^r colonies, 6400 (64%) of which were recombinants (white) (see Section 3.2). After replica-plating onto starch plates to screen for amylase production, one recombinant colony was found to produce a starch hydrolysis zone. This amylase positive colony was found to have a recombinant plasmid (pQR300) which consisted of pUC8 plus a 5.7kb *Bam*HI insert. Southern blotting experiment (Section 3.2) confirmed that the 5.7kb insert found in pQR300 had come from the chromosomal DNA of *S. thermoviolaceus* CUB74.

Attempts to screen the DNA library for protease and lipase production were not successful. *E. coli* pQR300 which contains and expresses the amylase gene of CUB74 secreted the enzyme into the periplasmic space (60%) and the culture medium (40%) (Section 3.6). The data in Table 3.3 show that the α -amylase is secreted into the culture medium of pQR300-containing *E. coli* cells under conditions where the alkaline phosphatase, a periplasmic enzyme, is still retained up to 91% in the periplasmic/cytoplasmic fraction. This implies a specific release into the medium of the amylase rather than a non-specific release of periplasmic proteins as has been seen when there is overproduction of periplasmic proteins (Suominen *et al.*, 1987). It is the exception rather than the rule for enzymes which are extracellular in their original Gram-positive host to be exported to the culture medium when cloned and expressed in *E. coli*. In most cases, Gram-positive extracellular enzymes are periplasmic when expressed in *E. coli*

(Pugsley, 1988). The smallest insert still expressing amylase is a 1.55kb *HindIII/SphI* fragment (pQR312, Fig.3.8). It is not clear whether any other proteins besides the α -amylase are required for the extracellular location in *E. coli*, although this is probably unlikely due to there being only one open reading frame in the 1.55kb insert in pQR312. The information needed for secretion beyond the periplasmic space may also be located in the coding sequence of the amylase gene.

The expression of cloned α -amylase in *E. coli* was not observed when the insert was subcloned in the opposite orientation with respect to the *lacZ* promoter (pQR303; see Section 3.5). The lack of amylase expression in this construct suggests that the *lacZ* promoter is responsible for amylase expression in *E. coli* pQR300. These experiments did not eliminate the possibility that the promoter of the amylase gene in pQR300 together with the *lacZ* promoter could be active in *E. coli*, and transcription from the amylase promoter in pQR303 might be counteracted by the activity of the *lacZ* promoter in which case no expression of the gene would be detected. Therefore, the amylase gene was cloned in both orientations in a vector called pQR1 which does not contain *lacZ*. The resulting plasmid constructs pQR308 and pQR309 (see Section 5.1) did not express amylase in *E. coli*. This supports the suggestion that the expression of amylase in *E. coli* is probably from the *lacZ* promoter and not from the promoter of the gene.

This barrier to expression of *Streptomyces* genes in *E. coli* has been previously observed (Horinouchi *et al.*, 1980; Bibb and Cohen, 1982; Rodgers *et al.*, 1982). This has been attributed in part to the presence of different classes of transcriptional initiation signals in *Streptomyces* which are presumably transcribed by RNA polymerase

holoenzymes having different recognition specificities (Westpheling *et al.*, 1985; Buttner, 1989). On the other hand, while the expression of amylase seemed to be possibly from the *lacZ* promoter, its production was not substantially induced by IPTG. This, in theory, might be a result of the high copy-number of the pUC plasmid which may titrate out the *lacI* repressor. However, Hoshiko *et al.* (1987) have reported the induction of *S. hygroscopicus* α -amylase in *E. coli* and found that the enzyme, whose gene had been cloned in pUC12, was induced by approximately 7 fold in the presence of IPTG.

7.2 Molecular weight determination of α -amylase expressed in E. coli and Streptomyces

The MW determination (from SDS-PAGE) for the secreted α -amylase of CUB74 gave a value of 50kDa for the mature protein which, giving the errors of MW determination by SDS-PAGE, is the same as that secreted by *E. coli* (Fig.3.10) and *S. lividans* (Fig.5.6). This similarity may result from the ability of *E. coli* to process the signal peptide in a similar manner to the original *Streptomyces* host. This result can only be proven by sequencing the N-terminus of the secreted enzyme from both strains. It is not a general case that *E. coli* will process the signal peptide in exactly the same manner as a Gram-positive organism; for example, the endo- β -*N*-acetylglucosidase H in its natural host, *S. plicatus*, is smaller than when it is expressed by *E. coli* (Robbins *et al.*, 1981) and it was suggested that a secondary cleavage, which occurs in Gram-positive secreted proteins, does not occur when the protein is synthesized and secreted into the periplasmic space by *E. coli* (Robbins *et al.*, 1984).

In the SDS-PAGE system (Fig.3.10), only one amylase activity was

found in the supernatant of *S. thermoviolaceus* CUB74. This does not exclude the possibility that there are other amylases secreted by this organism but they are not detected in this system. The properties of the CUB74 α -amylase described in Chapter Four (Section 4.1) show that maltotriose, maltose, and glucose are end-products of starch digestion by the enzyme, therefore the organism could sustain its growth by only using this one activity but it is likely that debranching and other types of amylases are also produced by this microorganism.

7.3 Expression of cloned α -amylase in *S. lividans*

In order to study the expression of amylase in *S. lividans*, low (pIJ903) and high (pQR1) copy-number shuttle vectors were used. When the *Bgl*III site of pQR1 was used for cloning the 5.7kb *Bam*HI fragment, the resulting plasmid constructs pQR308 and pQR309 (Fig.5.1) were stable in *E. coli*. These constructs, however, were very unstable in *S. lividans* and underwent large deletions which removed the cloned DNA and a part of the vector. Similar problems were also encountered when the 5.7kb fragment was inserted in the *Bgl*III site of the high copy-number plasmid pIJ702. This could be due to the presence of unstable sequences carried by the insert. This was avoided by cloning a smaller DNA fragment, a 1.7kb *Bam*HI-*Sph*I fragment, in pIJ702. The recombinant plasmid construct pQR311 (Fig.5.2) was stable in *S. lividans* and expression of the amylase gene was obtained. Cloning of the whole 5.7kb fragment was successful only when the low copy-number plasmid pIJ903 was used (pQR322 and pQR323, Fig.5.8).

Scanning of one of the protein gels indicated that the protein band corresponding to α -amylase activity constitutes more than 17% of total extracellular proteins produced by *S. lividans* pQR311. The data shown

in Chapter Three, strongly suggest that the amylase gene is transcribed in the direction of *Bam*HI to *Sph*I in the 1.7kb *Bam*HI-*Sph*I fragment. This, in pQR311, would place the amylase gene in the opposite orientation with respect to the *mel* promoter of pIJ702. The sequence data of the 1.7kb fragment (Fig.6.4) show that there is a possible promoter region upstream of the gene by comparison with those of *S. limosus* and *S. venezuelae* α -amylase genes (Fig.6.5). The results of the high resolution S₁ mapping show that this region is the promoter region and transcription starts at nt position 124-126 (see Chapter Six).

A 1.55kb *Hind*III-*Eco*RI fragment containing the amylase gene but not its promoter was subcloned in pQR1 that had been cut with the same enzymes to yield pQR318 (Fig.5.4). The 1.55kb fragment was isolated from pQR317 (Fig.5.4), a construct made by cutting pQR313 with *Sph*I and religating the large DNA band to remove one of the two *Hind*III sites in this plasmid construct. Surprisingly, *S. lividans* pQR318 produced high amounts of α -amylase as can be seen in Fig.5.5. The expression of α -amylase in cells containing this construct has to be attributed to readthrough from promoter(s) within the vector. The transcriptional start of the amylase gene in pQR318 was mapped within the pBR325 part of pQR1 (Fig.6.9). This means that *S. lividans* is recognizing a promoter which has fortuitously arisen in the construction of pQR318. This promoter has -10 and -35 regions that are quite similar to other *Streptomyces* promoters (Fig.6.10; Table 7.1). Identifying promoter activity on the pBR325 part of pQR1 in *S. lividans* may serve as an example for the possible usage of CUB74 α -amylase in the construction of promoter probe vectors.

Table 7.1 Comparison between different *Streptomyces* promoter sequences

Promoter	-35 Region	Distance (bp)	-10 Region	mRNA start	Reference
<i>amyP1</i>	TTGACG	19	CAGGCT	GA	Hoshiko <i>et al.</i> , 1987
<i>endoH</i>	TTGACT	21	CAGGGG	G	Westpheling <i>et al.</i> , 1985
<i>ermEP1</i>	TGGACA	14	TAGGAT	C	Bibb <i>et al.</i> , 1985
<i>stlP</i>	TTGACC	17	TACGGT	GC	Long <i>et al.</i> , 1987
<i>stvP</i>	TTGACC	17	TACGGT	GAAAACA GTT	Virolle <i>et al.</i> , 1988
<i>sttP</i>	TTGACC	17	TACGGT	CG	This work
pQR318P	TTAACT	17	AAAGCT	TTC	This work

stl: *S. limosus*; *stv*: *S. venezuelae*; *stt*: *S. thermoviolaceus*.

pQR318 was unstable in conditions where *S. lividans* was grown on half-strength nutrient agar and at 37°C. Two populations of colonies were obtained, a minor population of colonies with large amylase zones and a major population with much smaller zones that resemble the control *S. lividans* pQR1 (Fig.7.1). This indicates that plasmid pQR318 is unstable under these conditions, although no further analysis was carried out. Plasmid instability can be of segregational or structural type. Segregational instability is a result of improper partitioning of plasmids to daughter cells and leads to the loss of the entire plasmid. In the case of pQR318, the cells which produce small amylase zones are thiostrepton resistant and therefore still contain at least a part of the original plasmid. It can therefore be assumed that pQR318 has undergone rearrangements or deletions which led to the loss of part or all the amylase gene in the majority of cells. When cultivated on R2YE plates and at 30°C, *S. lividans* pQR318 also gave rise to colonies with small zones but this population constituted of only 3-5% of the total colonies (see Fig.5.5).

7.4 Regulation of α -amylase in *Streptomyces*

The data in Chapter Five (Section 5.3.2) showed that the smallest sugar molecule capable of inducing α -amylase in *S. thermoviolaceus* CUB74 is maltotriose. Of the other sugars tested, maltotetraose and maltopentaose, which are oligosaccharides with α -1,4 glucosidic bonds, also induced α -amylase. It is not known whether larger maltodextrins themselves are inducers or whether they are first degraded to maltotriose. Glucose and maltose (a sugar made of two α -1,4-linked glucose residues) did not have any effect on the production of amylase in this *Streptomyces* species. In addition, cellobiose, a sugar made of

Fig.7.1 Amylase zones produced by *S. lividans* pQR318. *S. lividans* pQR318 was grown at 37°C for two days, on half-strength nutrient agar media supplemented with thiostrepton and starch. The plate was then stained with iodine. Two types of starch hydrolysis zones (small and large) can be seen around the colonies.

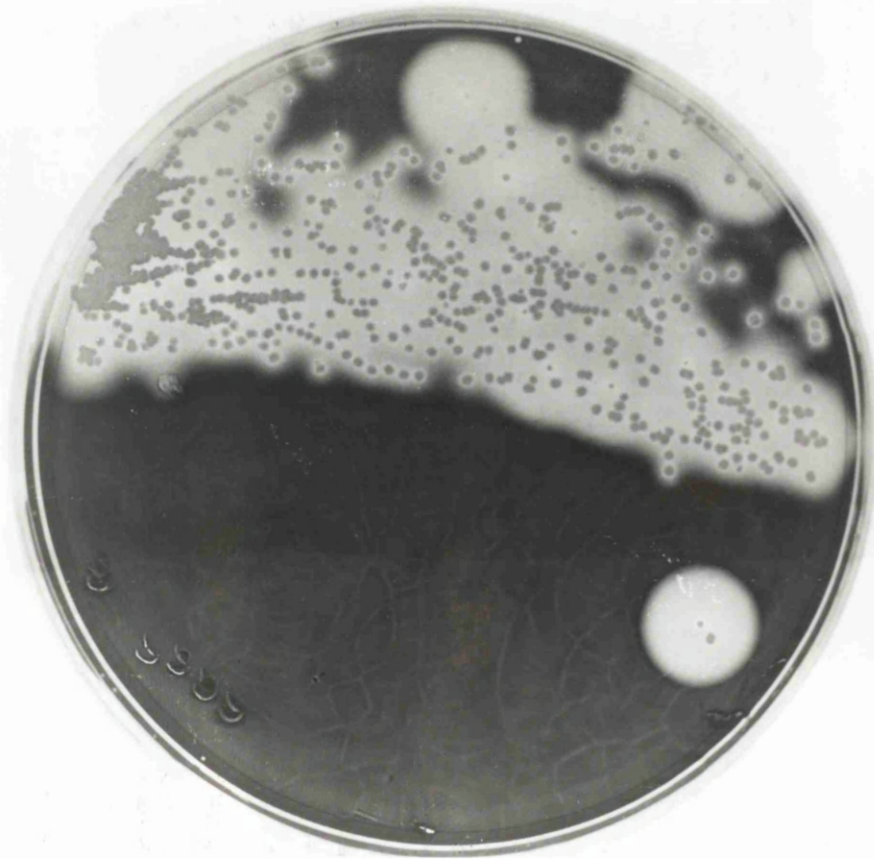

two glucose residues linked by a β -1,4 glucosidic bond, did not have any effect on α -amylase production. This suggests a high degree of inducer specificity as it would be necessary for an organism not to waste resources on the synthesis of a protein in response to the wrong signal.

Induction of the cloned α -amylase in *S. lividans* (pQR319, 322 and 323) was also investigated. It was found that α -amylase activity in *S. lividans* harbouring any of these constructs cannot be induced by any of the sugars used. Its activity remained unchanged (Table 5.2) i.e. constitutive in these constructs in *S. lividans*. The possibility of amylase being part of a maltose regulon in streptomycetes (as is the α -amylase gene in *E. coli*; Freundlieb and Boos, 1986) could be ruled out since induction did not occur when the amylase gene was subcloned on a low copy-number plasmid in *S. lividans*. Alternatively and if such a regulon exists in streptomycetes, the regulatory proteins that may be involved in induction in *S. lividans* are not trans-acting proteins since induction of CUB74 α -amylase in this species is not exhibited. It is likely, therefore, that the necessary trans-acting regulatory proteins involved in induction in *S. thermoviolaceus* CUB74 are not encoded by the 5.7kb *Bam*HI fragment. The regulation of CUB74 α -amylase is likely to be by negative control since in pQR311 transcription is still initiated without the presence of inducer (at the GGC 89-91bp upstream of the α -amylase ORF; see Chapter Six). This suggests that the promoter is constitutively active on the 1.7kb fragment (in pQR311) between the *Hind*III site and the junction with the vector (*Bam*HI/*Bgl*III). Regulation in its natural host would probably be by a repressor protein binding to DNA sequences downstream from the

presumptive promoter.

The regulation of α -amylases from two mesophilic *Streptomyces*, *S. limosus* and *S. venezuelae*, has been studied. Virolle and Bibb (1988) reported the induction of *S. limosus* α -amylase by maltose in *S. lividans* and the parent strain *S. limosus*, and they suggested that the enzyme could be part of a maltose regulon in streptomycetes. Also, Virolle *et al.* (1988) reported the induction of *S. venezuelae* α -amylase by maltose in *S. lividans*, *S. coelicolor*, and the parent strain. The promoter regions of the genes specifying these enzymes possess hexanucleotide sequences similar to the sequence GGA(T/G)GA found overlapping the -35 region of all sequenced maltose-regulated promoters both in *E. coli* (Debarbouille *et al.*, 1978; Freundlieb and Boos, 1986) and *Klebsiella pneumoniae* (Chapon and Raibaud, 1985) and believed to be part of the binding site for MalT, the activator of the maltose regulon (Raibaud *et al.*, 1985; Chapon and Raibaud, 1985). However, it was recently found that maltotriose rather than maltose is the true inducer of the maltose regulon of *E. coli* (Raibaud and Richet, 1987). No obvious similar sequences could be found in the promoter region of *S. thermoviolaceus* α -amylase implying the existence of a different regulatory system in this species, hence its study may provide further insight in gene regulation in this industrially important genus.

Different carbon sources were also tested for their effect on α -amylase induction (see Chapter Five). The data in Table 5.3 show that only mannitol represses α -amylase induction in *S. thermoviolaceus*. Surprisingly, glucose did not have any effect. Similar data has been reported in the case of *S. limosus* α -amylase (Virolle and Bibb, 1988).

This enzyme was repressed by mannitol in *S. limosus* and by glucose when cloned in *S. lividans* and *S. coelicolor*. It was suggested that these properties are host-determined. The absence of glucose repression in *S. limosus* did not appear to result from an inefficient system of glucose uptake as this species was able to grow at approximately the same rate on glucose and on mannitol. It was suggested that the glucose kinase of *S. limosus* may lack the regulatory property of that found in *S. coelicolor* (Virolle and Bibb, 1988).

Surprisingly, *S. thermoviolaceus* cultures grown in NMMP in the absence of added carbon sources produced reasonable levels of amylase. Presumably, the 0.5% casamino-acids present in NMMP served as a carbon source for these cells.

7.5 Characterization of α -amylase

The paper chromatography analysis results suggest that the enzyme is an α -amylase (Fig.4.1). In this experiment, sugar intermediates larger than maltotriose appeared as a result of starch hydrolysis by the enzyme early in the time course while maltose and small amounts of glucose accumulated towards the end of the experiment. Amylolytic activity of this enzyme towards other substrates was not tested and therefore the ability of the enzyme to hydrolyse glucosidic linkages other than α -1,4 is not known.

The activity expressed by the cloned α -amylase gene in *E. coli* has a surprisingly extended stability in the presence of calcium ions. At 50°C, 100% of the starting activity remains after 22h (Fig.4.4). At 60°C, this has only dropped to 75% after 22h. The effect of high temperatures on the enzyme stability was also investigated in the

presence and absence of calcium; from the data shown in Table 4.1, 70% of the starting activity remains after one hour at 70°C in the presence of calcium ions. The presence of Ca^{2+} therefore substantially increases the stability to thermal denaturation. The effect of calcium on the thermal stability of several extracellular proteins has long been observed, for example many extracellular enzymes from *Bacillus* species are stabilized by binding Ca^{2+} (Norman, 1979). The amount of calcium ions bound has been reported to vary from one to ten (Vihinen and Mantsala, 1989). Four Ca^{2+} are bound to the enzymes of *B. stearothermophilus* and *B. amyloliquefaciens* (Hsiu et al., 1964). Calcium is suggested to bind to one of the conserved regions of α -amylases (Rogers, 1985) and may be stabilizing the enzyme by tightening the binding of its different domains or counteracting the influence of negative charges in the molecule (Ward and Moo-Young, 1988).

The stability in the presence of substrate has also been tested. The results suggest even greater stability in the presence of starch and Ca^{2+} than for Ca^{2+} alone (Table 4.2). The stabilizing effect of substrate could be due to the presence of calcium as an impurity in starch, and it could be that the conformation of the enzyme becomes more rigid when it binds to the substrate which leads to higher stability against denaturing conditions (Vihinen and Mantsala, 1989). However, amylases from *Thermoactinomyces* sp.15 (Obi and Odibo, 1984) and *Thermoplasma curvata* (Glymph and Stutzenberger, 1977) are not stabilized by starch.

The enzyme was also inhibited by the α -amylase inhibitor, tendamistat. Tendamistat is a potent inhibitor of mammalian α -amylases

(Hofmann *et al.*, 1985; Vertesy *et al.*, 1984). The possible site of interaction (Phe-Glu-Trp) with inhibitor has been found in *S. thermoviolaceus* α -amylase (see Section 7.7). This site has also been found in *S. limosus* and *S. venezuelae* enzymes (Virolle *et al.*, 1988).

7.6 DNA sequence of α -amylase gene and analysis of its regulatory region

The gene specifying the α -amylase was sequenced (Fig.6.4). Its G+C content is 69% which is typical of *Streptomyces* DNA. This high G+C content results in a biased codon usage with the third position of most codons being G or C. There is also a tendency for codons to end in a C where there is a choice between a G or a C in the third position.

Several attempts to prepare RNA from CUB74 were not successful. It could be due to several reasons such as the presence of RNases or the difficulty in lysing the cells. However, no problems were encountered when RNA from *S. lividans* was prepared. The Northern blotting experiment showed that three RNA species are detected in *S. lividans* pQR311 (Fig.6.8), the smallest of which (1.5kb) corresponds to transcription from the promoter of the gene itself. The other two (2 and 3kb) could have been obtained from readthrough from other promoters situated on the vector pIJ702. This observation was confirmed by results obtained in the high resolution S₁ mapping experiment (Fig.6.9), where an additional RNA protected band of the same size as that of the intact probe itself was detected. Alternatively, this band could have resulted from reannealing of the probe but this is unlikely since no reannealed probe was detected in

pIJ702, pQR1, or pQR318 used in the same experiment and under the same conditions.

The high resolution S₁ mapping results showed that the amylase gene is also transcribed from its own promoter in pQR311 and the transcriptional start site GGC is located 89-91bp upstream from the ATG translational start codon. From the size of amylase mRNA (1.45kb) and the location of the transcription start site, the transcription termination site is calculated to be located between 10 and 80bp downstream from the translational termination codon. In this region, there is a perfect inverted repeat of 9nt, spanning nt positions 1621-1646, which may be a transcription terminator analogous to the Rho-factor-independent terminators of *E. coli*, although it is not followed by the stretch of T residues typical of the latter (Rosenberg and Court, 1979).

The sequence corresponding to the potential -35 region (TTGACC) is very similar (5 of 6 residues) to that of the typical eubacterial promoter. The sequence corresponding to the potential -10 region (TACGGT) is also similar to the eubacterial promoter and the distance between this region and the potential -35 region is 17bp, which is the optimal distance observed in *E. coli* (Hawley and MacClure, 1983). The reason why this promoter is not functional in *E. coli* is not known. Similarly, *ermEP1* and *ermEP2* promoters of the erythromycin phosphotransferase gene of *S. erythreus*, which also resemble the typical eubacterial promoter, do not function in *E. coli* (Bibb *et al.*, 1986).

Upstream from the presumptive promoter of CUB74 α -amylase, there is an inverted repeat of 8 nucleotides spanning nt positions 50-68, which

may act as a transcription terminator to stop readthrough from promoter sequences further upstream. Within this inverted repeat there is a translational stop codon TGA (at nt position 54) of a possible ORF that lies upstream of this inverted repeat. The function of this probable protein is not known but its separation from the cloned CUB74 α -amylase gene during cloning may account for the lack of induction of the cloned amylase in *S. lividans* pQR322, pQR323, and pQR319.

ORFs were also found upstream from *S. limosus* and *S. venezuelae* amylase genes (Virolle *et al.*, 1988) and thought to encode sugar-binding proteins directly involved in regulating amylase expression.

Transcription of amylase in pQR318 was also investigated (see Chapter Six). The transcriptional start site (corresponding to the most intense S_1 -protected band) in this construct was located at the nucleotides TTC 9-11 bp downstream from the *Hind*III site (Fig.6.10). Potential -35 (TTAACT) and -10 (AAAGCT) regions were identified in the pBR325 plasmid. The distance between these two potential elements is 18bp. This potential promoter (pQR318P) is of an *E. coli* origin but it is non-functional in this species as *E. coli* pQR318 was amylase negative. In the S_1 experiment, a ladder of protected bands was obtained with *S. lividans* pQR318 (Fig.6.9). In this ladder, the topmost (less intense) band might represent another transcriptional start site which resulted from the activity of another and less efficient promoter than pQR318P. pQR318P has fortuitously arisen in the construction of pQR318 and is quite similar to other *Streptomyces* promoters (Table 7.1).

7.7 Homology comparison of CUB74 α -amylase with those of other species

The predicted amino acid sequence of *S. thermoviolaceus* α -amylase was

optimally aligned to those of *S. limosus* (Long *et al.*, 1987), *S. venezuelae* (Virolle *et al.*, 1988), *S. hygroscopicus* (Hoshiko *et al.*, 1987) and pig pancreas (Kluh, 1981). The streptomycete α -amylases are highly homologous and have identity ranging from 55 to 75% (Table 6.4; Virolle *et al.*, 1988) which implicates that they have derived from a common ancestral gene. The greater degree of similarity (75% identity) is between *S. limosus* and *S. venezuelae* α -amylases (Virolle *et al.*, 1988). However, these enzymes fall into two categories, *S. limosus* and *S. venezuelae* enzymes which have an extended C-terminus sequence thought to play a role in binding raw starch (Svensson *et al.*, 1989), and *S. hygroscopicus* and *S. thermoviolaceus* enzymes which lack this terminal sequence motif. This motif is found in a wide variety of starch-degrading enzymes but it is not universally required since most α -amylases do not have this domain and can still attack granular starch (Sandstedt and Ueda, 1969).

From the aa alignment with the *S. limosus* α -amylase sequence, a signal sequence of 28aa can be identified at the N-terminus of the CUB74 α -amylase. This sequence includes a positively charged arginine residue at the amino terminus, an extremely hydrophobic core region, and two proline residues immediately preceding the amino terminus of the mature protein. The proline residues are likely to induce a turn in the signal peptide exposing the signal peptidase cleavage site (Chang, 1987).

There is also a remarkable degree of homology between the extracellular forms of *S. thermoviolaceus* and pig pancreatic enzymes (44% identity). The identity between these two enzymes extends almost throughout the sequence. It might be postulated that this high degree

of similarity between the streptomycete and mammalian enzymes originates from a common ancestral gene or possibly from a common and more recent evolutionary branch point (Long *et al.*, 1987). Long *et al.* (1987) reported that streptomycete, mammalian, and invertebrate enzymes are homologous whereas little similarity could be detected between streptomycete enzymes and those of fungal, plant, or other bacterial origin. The close similarity between streptomycete and mammalian α -amylases is further strengthened by the finding that the former are also inhibited by tendamistat (this work; Long *et al.*, 1987), a potent inhibitor of mammalian α -amylases which acts in an irreversible manner. Tendamistat competes with substrate to bind to the α -amylase of *S. tendae* (Koller, 1986) and has no effect on all other eubacterial and fungal α -amylases tested (Hofmann *et al.*, 1985).

Four proteinaceous inhibitors of mammalian α -amylases produced by *Streptomyces* species have been sequenced. These inhibitors are AI-3688 from *S. aureofaciens* (Vertesy and Tripier, 1985), Z-2685 from *S. parvulus* (Hofmann *et al.*, 1985), Hoe-467 A from *S. tendae* (Aschauer *et al.*, 1981), and Haim from *S. griseosporus* (Murai *et al.*, 1985). In the amino terminal region of each inhibitor, there is a highly conserved triplet, Trp-Arg-Tyr (Hofmann *et al.*, 1985). This triplet is situated in the middle of a disulfide ring in a spatially exposed position. The integrity of this ring seems to be essential for efficient inhibition (Vertesy *et al.*, 1984). Hofmann *et al.* (1985) observed the sequence Phe-Glu-Trp in the amino terminal region of all mammalian and invertebrate α -amylases but not in those of fungal, plant, or eubacterial origin. Based on the work of Burley and Petsko (1985) on aromatic interactions, Hofmann *et al.* (1985) suggested that

the triplet Phe-Glu-Trp is a possible candidate for interaction with the triplet Trp-Arg-Tyr of the inhibitor. The triplet Phe-Glu-Trp is also present in the amino terminal region of *S. thermoviolaceus*, *S. limosus*, and *S. venezuelae* enzymes (Fig.6.6). In *S. hygrosopicus*, however, the third amino acid of the triplet Trp is replaced by Arg (Fig.6.6) and it would be of interest to determine the effect of tendamistat on this enzyme.

7.8 Conclusions

1- A thermostable α -amylase gene was isolated from *S. thermoviolaceus* CUB74 and cloned in *E. coli* and *S. lividans*. Expression of the cloned CUB74 α -amylase gene in *E. coli* was from the *lacZ* promoter and not from its own promoter. *E. coli* pQR300 exported the cloned α -amylase to the periplasmic space and the culture medium.

2- Expression of the cloned CUB74 α -amylase in *S. lividans* pQR311 was from the promoter of the gene itself and a result of readthrough from other promoters on the plasmid pIJ702. This was also deduced from the results of high resolution S₁-mapping. The start of transcription initiated from the promoter of the gene was mapped and the presumptive -10 and -35 regions were located.

3- The production of α -amylase by *S. lividans* pQR322 and pQR323 did not respond to induction by the sugars tested. However, amylase production in the parent *S. thermoviolaceus* strain was subject to induction by maltotriose and repression by mannitol. This might indicate that the reason why induction of amylase does not occur in *S. lividans* is because other regulatory protein(s) that may mediate induction in CUB74 have not been cloned together with the α -amylase gene. The regulation in CUB74 is likely to be via negative control.

4- The α -amylase gene was sequenced and found to have a GC content of 69%. The sequence comprises an open reading frame (ORF) with translational start and stop codons defining an ORF of 459aa with a molecular weight of 49kDa. At the N-terminus of this enzyme, there is a putative leader sequence of 28aa.

5- The predicted amino acid sequence of the enzyme is highly similar to those of other streptomycetes (*S. limosus*, *S. venezuelae*, and *S. hygroscopicus*) and mammalian (pig pancreas) α -amylases.

6- Calcium and starch stabilize the enzyme to heat. Like the *S. limosus* and *S. venezuelae* enzymes, the CUB74 enzyme is inhibited by tendamistat.

7- The CUB74 α -amylase may have some uses as a candidate for constructing promoter probe vectors or for protein fusion and secretion studies since it is easily assayed and its expression leads to the appearance of zones around colonies on starch plates even before staining with I_2 solution. It is expressed in *E. coli* and secreted in high amounts into the culture media. This makes its isolation easy since it avoids problems associated with cell breakage. Furthermore, the enzyme assay can be carried out at a high temperature 60-70°C which eliminates background caused by any amylase activity of a mesophilic host, e.g., *S. lividans*.

8- The CUB74 α -amylase system provides a useful *Streptomyces* tool to study regulation in this industrially important genus. Regulation of this enzyme in *S. lividans* is worth further investigation. It would be of interest to determine the factor(s) involved in the regulation of CUB74 amylase so that regulatory proteins can be identified.

9- The original aims of this work were achieved. However, this

investigation can be taken further. The enzyme can be purified to homogeneity and the N-terminus of the protein expressed in *Streptomyces* and *E. coli* can be sequenced so that processing site(s) can be accurately identified. Specificity and action pattern of the purified enzyme towards different substrates can be determined.

REFERENCES

- Abdullah, M. & French, D. (1970) Substrate specificity of pullulanase. *Archives Biochem. Biophys.* 137:483-493.
- Allam, A.M., Hussein, A.M. & Ragab, A.M. (1975) Amylase of the thermophilic actinomycete *Thermonospora vulgaris*. *Z. Allg. Mikrobiol.* 15:393-398.
- Andrews, L. & Ward, J. (1987) Extracellular amylases from *Streptomyces albus* G. *Biochem. Soc. Trans.* 15:522-523.
- Argos, P., Rossmann, M.G., Grau, J.M., Zuber, H., Frank, G. & Tratschin, J.D. (1979) Thermal stability and protein structure. *Biochem.* 18:5698-5703.
- Aschauer, H., Vertesy, L. & Braunitzer, G. (1981) The sequence of the α -amylase inhibitor Hoe-467 A from *Streptomyces tendae* 4158. *Hoppe-Seyler's Z. Physiol. Chem.* 362:465-467.
- Banno, Y. & Nozawa, Y. (1985) Purification and characterization of lysosomal α -glucosidase secreted by eukaryote *Tetrahymena*. *J. Biochem.* 97:409-413.
- Benigni, R., Antony, P.P. & Carere, A. (1975) Estimate of the genome size by renaturation studies in *Streptomyces*. *Appl. Microbiol.* 30:324-336.
- Berdy, J. (1980) Recent advances in and prospects of antibiotic research. *Process. Biochem.* Oct/Nov:28-35.
- Berk, A.J. & Sharp, P.A. (1977) Sizing and mapping of early adenovirus mRNAs by gel electrophoresis of S1 endonuclease-digested hybrids. *Cell* 12:721-732.

Bernan, V., Filpula, D., Herber, W., Bibb, M. & Katz, E. (1985) The nucleotide sequence of the tyrosinase gene from *S. antibioticus* and characterization of the gene product. *Gene* 37:101-110.

Bibb, M.J. & Cohen, S.N. (1982) Gene expression in *Streptomyces*: construction and application of promoter-probe plasmid vectors in *Streptomyces lividans*. *Mol. Gen. Genet.* 187:265-277.

Bibb, M.J., Freeman, R.F., & Hopwood, D.A. (1977) Physical and genetical characterization of a second sex factor, SCP2, for *Streptomyces coelicolor* A3(2). *Mol. Gen. Genet.* 154:155-166.

Bibb, M.J., Ward, J.M. & Hopwood, D.A. (1978) Transformation of plasmid DNA into *Streptomyces* protoplasts at high frequency. *Nature* 274:398-400.

Bibb, M.J., Janssen, G.R. & Ward, J.M. (1986) Cloning and analysis of the promoter region of the erythromycin resistance gene of *S. erythrocaeus*. *Gene* 41:E357-E368.

Bibb, M.J., Jones, G.H., Joseph, R., Buttner, M.J. & Ward, J.M. (1987) The agarase gene (*dagA*) of *Streptomyces coelicolor* A3(2): affinity purification and characterization of the cloned gene product. *J. Gen. Microbiol.* 133:2089-2096.

Birnboim, H.C. & Doly, J. (1979) A rapid alkaline extraction procedure for screening recombinant plasmid DNA. *Nucleic Acids Res.* 7:1513-1523.

Brock, T.D. (ed.) (1986) Introduction: an overview of the thermophiles. In *Thermophiles, General, Molecular and Applied Microbiology*. pp. 1-16. Willey, New York.

Buisson, G., Duee, E., Hase, R. & Payan, F. (1987) Three dimensional structure of porcine pancreatic α -amylase at 2.9 Å

resolution. Role of calcium in structure activity. *EMBO J.* 6:3909-3916.

Buonocore, V., Caporale, C., de Rosa, M. & Gambacorta, A. (1976) Stable, inducible thermophilic α -amylase from *Bacillus acidocaldarius*. *J. Bacteriol.* 128:515-521.

Burley, S.K. & Petsko, G.A. (1985) Aromatic-aromatic interaction, a mechanism of protein structure stabilization. *Science* 229:23-28.

Buttner, M.J. (1989) RNA polymerase heterogeneity in *Streptomyces coelicolor*. *Mol. Microbiol.* 3:1653-1659.

Catley, E.Z., Robyt, J.F. & Whelan, W.J. (1966) A minor structural feature of pullulan. *Biochem. J.* 100:5-6.

Chang, S. (1987) Engineering for protein secretion in Gram-positive bacteria. *Methods Enzymol.* 153:507-516.

Chapon, C. & Raibaud, O. (1985) Structure of two divergent promoters located in front of the gene encoding pullulanase in *Klebsiella pneumoniae* and positively regulated by the *malt* product. *J. Bacteriol.* 164:639-645.

Chater, K.F. (1984) Morphological and physiological differentiation in development. In *Microbial Development*. Losik, R & Shapiro, L. (eds). pp. 89-116. Cold Spring Harbor Laboratory, Cold Spring Harbor, N. Y.

Chater, K.F., Hopwood, D.A., Kieser, T., & Thompson, C.J. (1982) Gene cloning in *Streptomyces*. *Current Topics in Microbiol. Immunol.* 97:69-95.

Chu, F.K., Trimble, R.B. & Maley, F. (1978) The effect of carbohydrate depletion on the properties of yeast external invertase. *J. Biol. Chem.* 253:8691-8693.

Debarbouille, M., Schuman, H.A., Silhavy, T.J. & Schwartz, M. (1978) Dominant constitutive mutations in *maltT*, the positive regulator gene of the maltose regulon in *Escherichia coli*. *J. Mol. Biol.* 124:359-371.

Dehottay, P., Dusart, J., Duez, C., Lenzini, M.V., Martial, J.A., Frere, J.M., Ghuysen, J.M. & Kieser, T. (1986). Cloning and amplified expression in *Streptomyces lividans* of a gene encoding extracellular β -lactamase from *Streptomyces albus* G. *Gene* 42:31-36.

Dehottay, P., Dusart, J., De Merter, F., Joris, B., Beeumen, J.V., Erpicum, J., Frere, J.M. & Kieser, T. (1987) Nucleotide sequence of the gene encoding the *Streptomyces albus* G β -lactamase precursor. *Eur. J. Biochem.* 166:345-350.

Demain, A.L., Aharonowitz, Y. & Martin, J.F. (1983) Metabolic control of secondary biosynthetic pathways. In *Biochemistry and Genetic Regulation of Commercially Important Antibiotics*. Vinng, L.C. (ed.). pp. 49-72. Reading, M.A: Addison-Wesley.

DePinto, J.A. & Campbell, L.L. (1968) Purification and properties of the cyclodextrinase of *Bacillus macerans*. *Biochem.* 7:121-125.

d'Enfert, C., Ryter, A. & Pugsley, A.P. (1987) Cloning and expression in *E. coli* of the *Klebsiella pneumoniae* genes for production, surface localization, and secretion of the lipoprotein pullulanase. *EMBO J.* 6:3531-3538.

Entian, K.D. & Frohlich, K.U. (1984) *Saccharomyces cerevisiae* mutants provide evidence of hexokinase PII as a bifunctional enzyme with catalytic and regulatory domains for triggering carbon catabolite repression. *J. Bacteriol.* 158:29-35.

Entian, K.D., Kopetzki, E., Frohlich, K.U. & Mecke, D. (1984) Cloning of hexokinase isoenzyme PI from *Saccharomyces cerevisiae*:

PI transformants confirm the unique role of hexokinase isoenzyme PII for yeasts. *Mol. Gen. Genet.* 198:50-54.

Flannigan, B. & Sellars, P.N. (1977) Amylase, β -glucosidase and β -xylosidase activity of thermotolerant and thermophilic fungi isolated from Barly. *Trans. Br. Mycol. Soc.* 69:316-317.

Fogarty, W.M. (ed.) (1983) Microbial amylases. In *Microbial Enzymes and Biotechnol.* pp. 1-92. Applied Science, London.

Fogarty, W.M. & Kelly, C.T. (1979) Starch-degrading enzymes of microbial origin. *Prog. Ind. Microbiol.* 15:87-150.

Fourney, R.M., Miyakoshi, J., Day III, R.S. & Paterson, M.C. (1988) Northern blotting: Efficient RNA staining and transfer. *Focus* 10:5-7.

Freundlieb, S. & Boos, W. (1986) Alpha-amylase of *E. coli*, mapping and cloning of the structural gene, *mals*, and identification of its product as a periplasmic protein. *J. Biol. Chem.* 261:2946-2953.

Frommel, C. & Hohne, W.E (1981) Influence of calcium binding on the thermal stability of thermitase, a serine protease from *Thermoactinomyces vulgaris*. *Biochim. Biophys. Acta.* 670:25-31.

Girvitz, S.C., Bacchetti, S., Rainbow, J.A., & Graham, L.F. (1980) A rapid and efficient procedure for the purification of DNA from agarose gels. *Anal. Biochem.* 106:492-496.

Glymph, J.L. & Stutzenberger, F.J. (1977) Production, purification, and characterization of α -amylase from *Thermonospora curvata*. *Appl. Environ. Microbiol.* 34:391-397.

Goodfellow, M., Lacey, J. & Carole T. (1987) Numerical classification of thermophilic streptomycetes. *J. G. Microbiol.* 133:3135-3149.

Gould, A.R., May, B.K. & Elliott, W.H. (1973) Accumulation of messenger RNA for extracellular enzymes as a general phenomenon in *Bacillus amyloliquefaciens*. *J. Mol. Biol.* 73:213-219.

Harada, T., Misaki, A., Akai, H., Yokobayashi, K. & Sugimoto, K. (1972) Characterization of *Pseudomonas* isoamylase by its action on amylopectin and glycogen: comparison with *Aerobacter pullulunase*. *Biochim. Biophys. Acta* 268:497-505.

Harris, J.I., Hocking, J.D., Runswick, M.J., Susuki, K. & Walker, J.E. (1980) D-glyceraldehyde-3-phosphate dehydrogenase: the purification and characterization of the enzymes from the thermophiles *Bacillus staerothermophilus* and *Thermus aquaticus*. *Eur. J. Biochem.* 108:535-547.

Hasegawa, A. & Imahori, K. (1976) Studies on an α -amylase from thermophilic bacterium. *J. Biochem.* 79:35-42.

Hawley, D.K. & McClure, W.R. (1983) Compilation and analysis of *E. coli* promoter DNA sequences. *Nucleic Acids Res.* 11:2237-2255.

Hein, W. & Lauwers, A.M. (1976) Amylase activity and stability at high and low temperature depending on calcium and other divalent cations. In *Enzymes and Proteins from Thermophilic Microorganisms*. Zuber, H. (ed). pp. 77-89. Birkhauser Verlag.

Henderson, G., Krugsman, P., Jun Lui, G. Davey, C.C. & Malek, L.T. (1987) Characterization and structure of genes for proteases A and B from *Streptomyces griseus*. *J. Bacteriol.* 169:3778-3784.

Herbert, D., Phipps, P.J. and Strange, R.E. (1971) Chemical analysis of microbial cells. In *Methods in Microbiol*, vol. 5B. Norris, J.R. and Ribbons, D.W. (eds). pp. 244-249. New York: Academic Press.

Higashihara, M. & Okada, S. (1974) Studies on β -amylase of *Bacillus megaterium* strain no. 32. *Agric. Biol. Chem.* 38:1023-1029.

Hodgson, D.A. (1982) Glucose repression of carbon source uptake and metabolism in *Streptomyces coelicolor* A3(2) and its perturbation in mutants resistant to 2-deoxyglucose. *J. Gen. Microbiol.* 128:2417-2430.

Hofmann, O., Vertesy, L. & Braunitzer, G. (1985) The primary structure of α -amylase inhibitor Z-2685 from *Streptomyces parvulus*, FH-1641. *Biol. Chem.* 366:1161-1168.

Hopwood, D.A., Chater, K.F., Dowding, J.E. & Vivian, A. (1973) Advances in *Streptomyces coelicolor* genetics. *Bacteriol. Reviews* 37:371-405.

Hopwood, D.A., Keiser, T., Wright, M.H., & Bibb, M.J. (1983) Plasmids, recombination and chromosome mapping in *Streptomyces lividans* 66. *J. Gen. Microbiol.* 129:2257-2269.

Hopwood, D.A. Bibb, M.J., Chater, K.F., Kieser, T., Bruton, C.J., Kieser, H.M., Lydiate, D.J., Smith, C.P., Ward, J.M., & Schrepf, H. (eds). (1985) Genetic Manipulation of *Streptomyces*: A Laboratory Manual. The John Innes Foundation, Norwich.

Hopwood, D.A., Bibb, M.J., Chater, K.F., Janssen, G.R., Malpartida, F. & Smith, C.P. (1986) Regulation of gene expression in antibiotic-producing *Streptomyces*. In *Regulation Of Gene Expression 25 Years On*. Booth, I.R. & Higgins, C.F. (eds). pp. 251-276. 39th Symposium of the Society for General Microbiology. Cambridge University Press, Cambridge.

Horinouchi, S., Uozumi, T., & Beppu, T. (1980) Cloning of *Streptomyces* DNA into *Escherichia coli*; absence of heterospecific gene expression of *Streptomyces* genes in *Escherichia coli*. *Agric. Biol. Chem.* 44:367-371.

Hoshiko, S., Makabe, O., Nojiri, C., Katsumata, K., Satoh, E., & Nagaoka, K. (1987) Molecular cloning and characterization of the *Streptomyces hygroscopicus* α -amylase gene. *J. Bacteriol.* 169:1029-1036.

Hsiu, J., Fischer, E.H. & Stein, E.A. (1964) Alpha-amylases as calcium-metalloenzymes. II. Calcium and the catalytic activity. *Biochem.* 3:61-66.

Hyun, H.H. & Zeikus, J.G. (1985) General biochemical characterization of thermostable pullulanase and glucoamylase from *Clostridium thermohydrosulfuricum*. *Appl. Environ. Microbiol.* 49:1168-1173.

Ikeda, H., Seno, E.T., Bruton, C.J. & Chater, K.F. (1984) Genetic mapping, cloning and physiological aspects of the glucose kinase gene of *Streptomyces coelicolor*. *Mol. Gen. Genet.* 196:501-507.

Kainuma, K., Wako, K., Kobayashi, S., Nogami, A. & Suzuki, S. (1975) Purification and some properties of a novel maltohexaose-producing exo-amylase from *Aerobacter aerogenes*. *Biochim. Biophys. Acta* 410:333-346.

Katsuragi, N., Takizawa, N. & Murooka, Y. (1987) Entire nucleotide sequence of the pullulanase gene of *Klebsiella aerogenes* W70. *J. Bacteriol.* 169:2301-2306.

Katz, F., Thompson, C.J., & Hopwood, D.A. (1983) Cloning and expression of the tyrosinase gene from *Streptomyces antibioticus* in *Streptomyces lividans*. *J. Gen. Microbiol.* 129:2703-2714.

Kendall, K. & Cullum, J. (1984) Cloning and expression of an extracellular agarase gene from *Streptomyces coelicolor* A3(2) in *Streptomyces lividans* 66. *Gene* 29:315-321.

Kieser, T. (1984) Factors affecting the isolation of CCCDNA from *Streptomyces lividans* and *Escherichia coli*. *Plasmid* 12:19-36.

Klibanov, A.M. (1983) Thermostabilization of enzymes. In *Advances in Applied Microbiology*, vol. 29. Laskin, A.I. (ed.), pp. 1-28. Academic Press, New York.

Kluh, I. (1981) Amino acid sequence of hog pancreatic α -amylase isoenzyme I. *FEBS Lett.* 136:231-234.

Laemmli, U.K. (1970) Cleavage of structural proteins during the assembly of the head of bacteriophage 4. *Nature* 227:680-685.

Ljungdahl, L.G. (1979) Physiology of thermophilic bacteria. In *Advances in Microbial Physiology*, vol. 19. Rose, A.H. & Morris, J.G. (eds). pp. 149-243. New York: Academic Press.

Long, C.M., Virolle, M-J., Chang, S. & Bibb, M.J. (1987) α -Amylase gene of *Streptomyces limosus*: Nucleotide sequence, expression motifs and a.a. sequence homology to mammalian and invertebrate α -amylase. *J. Bacteriol.* 169:5745-5754.

Lydiate, D.J., Malpartida, F. & Hopwood, D.A. (1985) The *Streptomyces* plasmid SCP2*: its functional analysis and development into useful cloning vectors. *Gene* 35:223-235.

Maniatis, T., Fritsch, E.F. & Sambrook, J. (eds). (1982) *Molecular Cloning: A Laboratory Manual*. Cold Spring Harbor, Cold Spring Harbor, N.Y.

Manners, D.J. (1974) The structure and metabolism of starch. In *Essays in Biochemistry*. vol. 10. Campbell, P.N. & Dickins, F. (eds). pp. 37-91. London: Academic Press.

Matsuura, Y., Kusunoki, M., Date, W., Harada, S., Bando, W., Tanaka, N. and Kakudo, M. (1979) Low resolution crystal structures

of Taka-amylase A and its complexes with inhibitors. *J. Biochem.* 86:1773-1783.

Matsuura, Y., Kusunoki, M., Harada, W., Tanaka, N., Iga, Y., Yasuoka, N., Toda, H., Narita, K. and Kakudo, M. (1980) Molecular structure of Taka-amylase A. I. Backbone chain folding at 3 Å resolution. *J. Biochem.* 87:1555-1558.

Matsuura, Y., Kusunoki, M., Harada, W. and Kakudo, M. (1984) Structure and possible catalytic residues of Taka-amylase A. *J. Biochem.* 95:697-702.

McKillop, C., Elvin, P., & Kenten, J. (1986) Cloning and expression of an extracellular α -amylase gene from *Streptomyces hygroscopicus* in *Streptomyces lividans* 66. *FEMS Microbiol. Lett.* 36:3-7.

Merkler, D.J., Farrington, G.K. & Wedler, F.C. (1981) Protein thermostability. *Intl. J. Peptide Res.* 18:430-442.

Michaelis, S., Chapon, S., d'Enfert, C., Pugsley, A.P. & Schwartz, M. (1985) Characterization and expression of the structural gene for pullulanase, a maltose-inducible secreted protein of *Klebsiella pneumoniae*. *J. Bacteriol.* 164:633-638.

Minoda, Y., Arai, M., Torigoe, Y. & Yamada, K. (1968) Acid-stable α -amylase of black aspergilli. III Separation of acid-stable α -amylase and acid-unstable α -amylase from the same mold amylase preparation. *Agric. Biol. Chem.* 32:110-113.

Minton, N.P., Atkinson, T. & Sherwood, R.F. (1983). Molecular cloning of the *Pseudomonas* carboxypeptidase G₂ gene and its expression in *Escherichia coli* and *Pseudomonas putida*. *J. Bacteriol.* 156:1222-1227.

Morosoli, R., Bertrand, J.L., Mondou, F., Shareck, F. & Kluepfel, D. (1986) Purification and properties of a xylanase from *Streptomyces lividans*. *Biochem. J.* 239:587-592.

Murai, H., Hara, S., Ikenaka, T., Goto, A., Arai, M. & Murao, S. (1985) Amino acid sequence of protein α -amylase inhibitor from *Streptomyces griseosporus* YM-25. *J. Biochem.* 97:1129-1133.

Nakajima, R., Imanaka, T. & Aiba, S. (1986) Comparison of amino acid sequences of eleven different α -amylases. *Appl. Microbiol. Biotechnol.* 23:355-360.

Nelson, N. (1944) A photometric adaptation of the Somogyi method for the determination of glucose. *J. Biol. Chem.* 153:375-380.

Neu, H.C. & Heppel, L.A. (1964) The release of enzymes from *Escherichia coli* by osmotic shock and during the formation of spheroplasts. *J. Biol. Chem.* 240: 3685-3692.

Nicholson, W.L. & Chambliss, G.H. (1985) Isolation and characterization of a cis-acting mutation conferring catabolite repression resistance to α -amylase synthesis in *Bacillus subtilis*. *J. Bacteriol.* 161:875-881.

Norman, B.E. (1979) The application of polysaccharide degrading enzymes in the starch industry. In *Microbial Polysaccharides and Polysaccharases*. Berkeley, R.C.W., Wooday, G.W., and Ellwood, D.C. (eds). pp. 338-376. Society for General Microbiology, London: Academic Press.

Obi, S.K. & Odibo, F.J.C. (1984) Some properties of a highly thermostable α -amylase from a *Thermoactinomyces* sp., *Can. J. Microbiol.* 30:780-785.

Ohba, R. & Ueda, S. (1982) An inductive effector in production of extracellular pullulanase by *Aerobacter aerogenes*. *Agric. Biol. Chem.* 46:2425-2431.

Oikawa, A. & Maeda, A. (1957) The role of calcium in Taka amylase A. *J. Biochem.* 44:745-746.

Pace, C.N. & MacGrath, T. (1980) Substrate stabilization of lysozyme to thermal and guanidine hydrochloride denaturation. *J. Biol. Chem.* 255:3862-3865.

Pazur, J.H. & Ando, T. (1960) The hydrolysis of glucosyl oligosaccharides with α -D-1,4 and α -D-1,6 bonds by fungal amyloglucosidase. *J. Biol. Chem.* 235:297-302.

Pazur, J.H. & Kleppe, K. (1962) The hydrolysis of α -D-glucosides by amyloglucosidase from *Aspergillus niger*. *J. Biol. Chem.* 237:1002-1006.

Pfueller, S.L. & Elliot, W.H. (1964) The extracellular α -amylase of *Bacillus stearothermophilus*. *Acta Microbiol.* 244:48-54.

Plant, A.R., Morgan, H.W. & Daniel, R.M. (1986) A highly stable pullulanase from *Thermus aquaticus* YT-1. *Enzyme Microb. Technol.* 8:668-672.

Ponnuswamy, P.K., Muthusamy, R. & Manavalan, P. (1982) Amino acid composition and thermal stability of proteins. *Int. J. Biol. Macromol.* 4:186-190.

Postma, P.W. (1986) Catabolite repression and related processes. In *Gene Expression-25 Years On*. Booth, I.R. & Higgins, C.F. (eds). pp. 21-49. Cambridge University Press.

Postma, P.W. & Lengeler, J.W. (1985) Phosphoenol-pyruvate: carbohydrate phosphotransferase system of bacteria. *Microbiol. Rev.* 49:232-269.

Pridham, T.G. & Tresner, H.D. (1974) Family VII. *Streptomycetaceae*. In *Bergey's Manual of Determinative Bacteriology*, 8th edition. Buchana, R.E. & Gibbons, W.E. (eds). pp. 747-748. Baltimore: Williams & Wilkins.

Priest, F.G. (1977) Extracellular enzyme synthesis in the genus *Bacillus*. *Bacteriol. Rev.* 41:711-780.

Pugsley, A.P. (1988) Getting out of *Escherichia coli*: protein secretion across the Gram-negative outer membrane. Das R.C., and Robbins, P.W. (eds). pp. 607-849. In *Protein Transfer and Organelle Biogenesis*. London: Academic Press.

Raibaud, O. & Richet, E. (1987) Maltotriose is the inducer of the maltose regulon of *Escherichia coli*. *J. Bacteriol.* 169:3059-3061.

Raibaud, O., Gutierrez, C. & Schwartz, M. (1985) Essential and non-essential sequences in *malPp*, a positively controlled promoter in *Escherichia coli*. *J. Bacteriol.* 161:1201-1208.

Robbins, P.W., Wirth, D.F. & Hering, C. (1981) Expression of the *Streptomyces* enzyme endoglycosidase H in *Escherichia coli*. *J. Biol. Chem.* 256:10640-10644.

Robbins, P.W., Trimble, R., Wirth, D.F., Hering, C., Maley, F., Maley, G., Das, R., Gilson, B.W., Royal, N. & Biemann, K. (1984) Primary structure of *Streptomyces* enzyme Endo- β -N-acetylglucosamidase H. *J. Biol. Chem.* 259:7577-7583.

Robyt, J. & French, D. (1963) Action pattern and specificity of an amylase from *Bacillus subtilis*. *Archives Biochem. Biophys.* 100:451-467.

Robynt, J.F. & Whelan, W.J. (1968) General introduction. *In Starch and its Derivatives*, 4th edition. Radley, J.A. (ed). pp. 423-497. London: Chapman and Hall.

Rodgers, W.H., Springer, W. & Young, F.E. (1982) Cloning and expression of *Streptomyces fradiae* neomycin resistance gene in *Escherichia coli*. *Gene* 18:133-141.

Rogers, J.C. (1985) Conserved amino acid sequence domains in α -amylase from plants, mammals and bacteria. *Biochem. Biophys. Res. Commun.* 128:470-476.

Rosenberg, M. & Court, D. (1979) Regulation sequences involved in the promotion and termination of RNA transcription. *Ann. Rev. Genet.* 13:319-353.

Ruegg, C., Ammer, D. & Lerch, K. (1982) Comparison of amino acid sequence and thermostability of tyrosinase from three wild type strains of *Neurospora crasse*. *J. Biol. Chem.* 257:6420-6426.

Saito, N. (1973) A thermophilic extracellular α -amylase from *Bacillus licheniformis*. *Archives Biochem. Biophys.* 155:290-298.

Sakano, Y., Hiraiwa, S., Fukushima, J. & Kobayashi, T. (1982a) Enzymatic properties and action patterns of *Thermoactinomyces vulgaris* α -amylase. *Agric. Biol. Chem.* 46:1121-1129.

Sakano, Y., Kashiwagi, Y. & Kobayashi, T. (1982b) Purification and properties of an exo- α -amylase from *Pseudomonas stutzeri*. *Agric. Biol. Chem.* 46:639-646.

Sakano, Y., Fukushima, J. & Kobayashi, T. (1983) Hydrolysis of α -1,4- and α -1,6-glucosidic linkages in trisaccharides by the *Thermoactinomyces vulgaris* α -amylase. *Agric. Biol. Chem.* 47:2211-2216.

Sanger, F., Nicklen, S. & Coulson, A.R. (1977) DNA sequencing with chain-terminating inhibitors. *Proc. Natl. Acad. Sci. USA* 74:5463-5467.

Sanger, F., Coulson, A.R., Barrel, B.G., Smith, A.J.H. & Roe, B.A. (1980) Cloning in single-stranded bacteriophage as an aid to rapid DNA sequencing. *J. Mol. Biol.* 143:161-178.

Schmidt, J. & John, M. (1979) Starch metabolism in *Pseudomonas stutzeri*. I. Studies on maltotriose-forming amylase. *Biochim. Biophys. Acta.* 566:88-99.

Seno, E.T. & Chater, K.F. (1983) Glycerol catabolic enzymes and their regulation in wild-type and mutant strains of *Streptomyces coelicolor* A3(2). *J. Gen. Microbiol.* 129:1403-1413.

Shimizu, M., Kanno, M., Tamura, M. & Suekane, M. (1978) Purification and more properties of a novel α -amylase produced by a strain of *Thermoactinomyces vulgaris*. *Agric. Biol. Chem.* 42:1681-1688.

Singleton, R. & Amelunxen, R.E. (1973). Proteins from thermophilic microorganisms. *Bacteriol. Rev.* 37:320-342.

Southern, E.M. (1975) Detection of specific sequences among DNA fragments separated on agarose gel electrophoresis. *J. Mol. Biol.* 98:503-517.

Srivastava, R.A.K. & Mathur, S.N. (1984) Regulation of amylase biosynthesis in growing and non-growing cells of *Bacillus stearothermophilus*. *J. Appl. Bacteriol.* 57:147-151.

Stanier, R.Y., Adelberg, E. & Ingraham, J.L. (eds) (1977) Gram-positive bacteria. In *General Microbiology*, 4th edition. pp. 672-703. MacMillan Press, London.

Suominen, I., Karp, M., Lahde, M., Kopiot, A., Glumoff, T., Meyer, P. & Mantsala, P., (1987) Extracellular production of cloned α -amylase by *Escherichia coli*. *Gene* 61:165-176.

Suzuki, Y. & Chishiro, M. (1983) Production of extracellular thermostable pullulanase by an amylolytic obligately thermophilic soil bacterium, *Bacillus stearothermophilus* Kp1064. *Appl. Microbiol. Biotechnol.* 17:24-29.

Suzuki, Y. & Imai, T. (1985) *Bacillus stearothermophilus* KP1064 pullulan hydrolase. Its assignment to a unique type of maltogenic α -amylase but to neither pullulanase nor isopullulanase. *Appl. Microbiol. Biotechnol.* 21:20-26.

Svensson, B., Jesersen, H., Sierks, M.R. and MacGregor, E.A. (1989) Sequence homology between putative raw-starch binding domains from different starch-degrading enzymes. *Biochem. J.* 264:309-311.

Takasaki, Y. (1976) Productions and utilizations of β -amylase and pullulanase from *Bacillus cereus* var. *mycoides*. *Agric. Biol. Chem.* 40:1515-1530.

Takasaki, Y. (1982) Production of maltohexaose by α -amylase from *Bacillus circulans* G-6. *Agric. Biol. Chem.* 46:1539-1547.

Takasaki, Y. (1983) An amylase producing maltotetraose and maltopentaose from *Bacillus circulans*. *Agric. Biol. Chem.* 47:2193-2199.

Takasaki, Y. (1985) An amylase-producing maltotriose from *Bacillus subtilis*. *Agric. Biol. Chem.* 49:1091-1097.

Takizawa, N. & Murooka, Y. (1985) Cloning of the pullulanase gene and overproduction of pullulanase in *Escherichia coli* and *Klebsiella aerogenes*. *Appl. Environ. Microbiol.* 49:294-298.

Taniguchi, H., Chung, M.J., Yoshigi, N. & Marugama, Y. (1983) Purification of *Bacillus circulans* F-2 amylase and its general properties. *Agric. Biol. Chem.* 47:511-519.

Taniguchi, H., Sata, H. & Maruyama, Y. (1986) Inhibition of *Bacillus circulans* F-2 amylase by guanine nucleotides. *Agric Biol. Chem.* 50:2423-2424.

Thirunavukkarasu, M. & Priest, F.G. (1980) Regulation of amylase synthesis in *Bacillus licheniformis* NCIB 6346. *FEMS Microbiol. Lett.* 7:315-321.

Thompson, C., Ward, J.M. & Hopwood, D.A. (1982) Cloning of antibiotic resistance and nutritional genes in streptomycetes. *J. Bacteriol* 151:668-677.

Toda, H., Kato, I. & Marita, K. (1968) Correlation of the masked sulphhydryl group with the essential calcium in Taka-amylase A. *J. Biochem.* 63:295-301.

Torriani, A. (1966) Alkaline phosphatase from *Escherichia coli*. Cantoni, G.L. and Davies, D.R. (eds). *In Procedures in Nucleic Acid Research*. Harper and Row, New York.

Vehmaanpera, J., Nybergh, P.M.A., Tanner, R., Pohjonen, E., Bergelin, R. & Korhola, M. (1987) Industrial production of α -amylase by genetically engineered *Bacillus*. *Enzyme Microb. Technol.* 9:546-549.

Vertesy, L. & Tripier, D. (1985) Isolation and structure elucidation of an α -amylase inhibitor, AI-3688, from *Streptomyces aurefaciens*. *FEBS Lett.* 185:187-190.

Vieira, J. & Messing, J. (1982) The pUC plasmids, an M13mp7 derived system for insertion mutagenesis and sequencing with synthetic universal primers. *Gene* 19:259-268.

Vihinen, M. & Mantsala, P. (1989) Microbial amyolytic enzymes. *Critical Rev. Biochem. Mol. Biol.* 24:329-418.

Vihinen, M. & Mantsala, P. (1990) Conserved residues of liquefying α -amylases are conserved in the vicinity of active site. *Biochem. Biophys. Res Commun.* 166:61-65.

Virolle, M-J. & Bibb, M.J. (1988) Cloning, characterization and regulation of an α -amylase gene from *Streptomyces limosus*. *Mol. Microbiol.* 2:197-208.

Virolle, M-J., Long, C.M., Chang, S., & Bibb, M.J. (1988) Cloning, characterization and regulation of an α -amylase gene from *Streptomyces venezuelae*. *Gene* 74:321-334.

Ward, O.P. & Moo-Young, M. (1988) Thermostable enzymes. *Biotech. Adv.* 6:39-69.

Westpheling, J., Raney, M. & Losick, R. (1985) RNA polymerase heterogeneity in *Streptomyces coelicolor*. *Nature* 313:22-37.

Williams, S.T., Goodfellow, M., Anderson, G., Wellington, E.M.H., Sneath, P.H.A & Sackin, M.J. (1983) Numerical classification of *Streptomyces* and related genera. *J. Gen. Microbiol.* 129:1743-1813.

Yamasaki, Y., Suzuki, Y. & Ozawa, J. (1976) Purification and properties α -glucosidase from *Penicillium purpurogenum*. *Agric. Biol. Chem.* 40:669-676.

Yamasaki, Y., Suzuki, Y. & Ozawa, J. (1977) Purification and properties of α -glucosidase from *Penicillium oxalicum*. *Agric. Biol. Chem.* 41:1451-1458.

Yanish-Perron, C., Vieira, J. & Messing, J. (1985) Improved M13 phage cloning vectors and host strains: nucleotide sequences of the M13mp18 and pUC19 vectors. *Gene* 33:103-119.

Yokobayashi, K., Misaki, A. & Harada, T. (1969) Specificity of *Pseudomonas* isoamylase. *Agric. Biol. Chem.* 33:625-627.

Yokobayashi, K., Akai, H., Sugimoto, T., Hirao, M., Sugimoto, K. & Harada, T. (1973) Comparison of the kinetic parameters of *Pseudomonas* isoamylase and *Aerobacter* pullulanase. *Biochem. Biophys. Acta.* 293:197-202.

Yoshigi, N., Chikano, T. & Kamimura, M. (1985) Purification and properties of an amylase from *Bacillus cereus* NY-14. *Agric. Biol. Chem.* 49:3369-3376.

Yutani, K. (1975) Role of calcium ion in the thermostability of α -amylase produced from *Bacillus stearothermophilus*. *Experientia Suppl.* 26:91-95.

Yutani, K., Ogashara, K., Sugino, Y. & Matsushiro, A. (1977) Effect of a single amino acid substitution on stability of conformation of a protein. *Nature* 267:274-275.

PUBLICATIONS

Bahri, S.M. & Ward, J.M. (1990) Cloning and expression of an α -amylase gene from *Streptomyces thermoviolaceus* CUB74 in *Escherichia coli* JM107 and *S. lividans* TK24. *J. Gen. Microbiol.* 136:811-818.

Bahri, S.M. & Ward, J.M. (1990) Nucleotide sequence analysis of an α -amylase gene isolated from *Streptomyces thermoviolaceus*. Submitted for publication.

Bahri, S.M. & Ward, J.M. (1990) Regulation of *Streptomyces thermoviolaceus* CUB74 α -amylase: Maltotriose is the smallest inducer in the parent host but no induction occurs upon cloning into *S. lividans*. In preparation.

Appendix 1

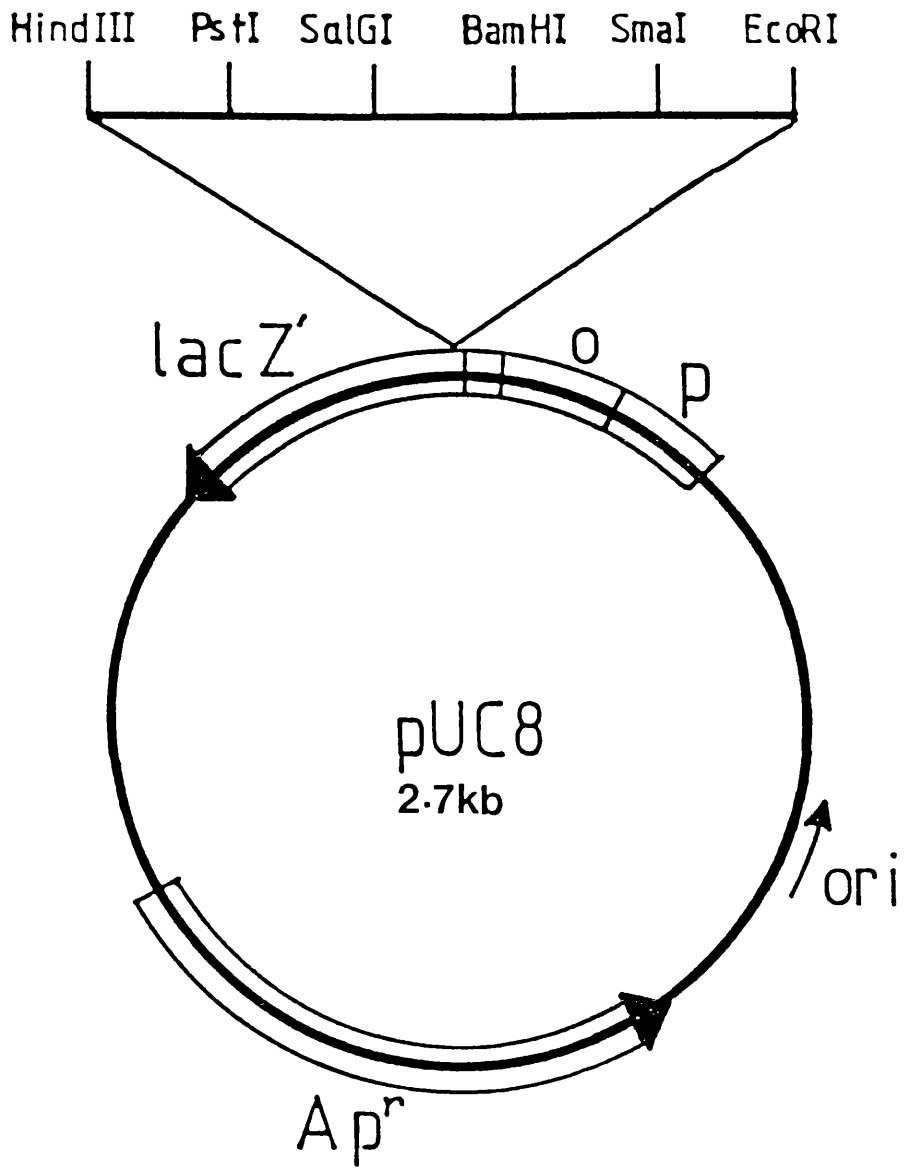

Appendix 2

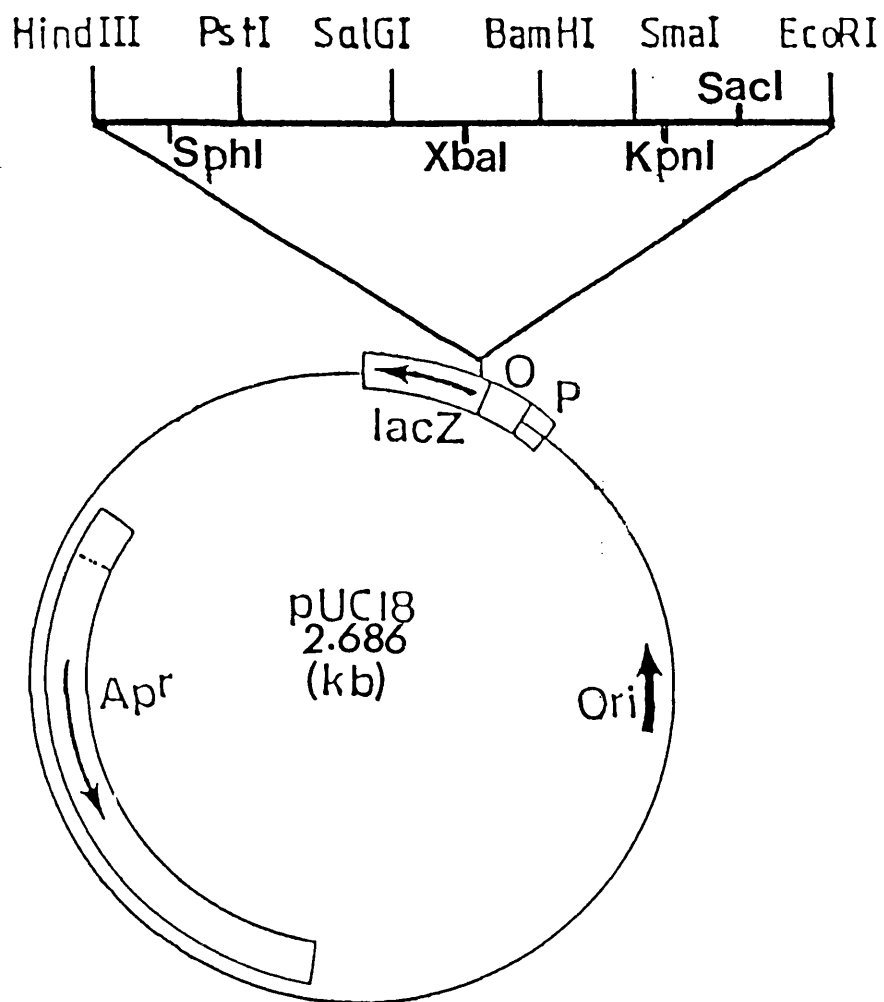

Appendix 3

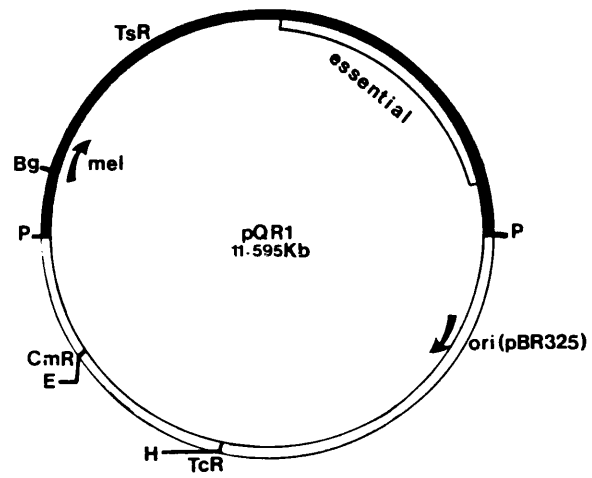

Appendix 4

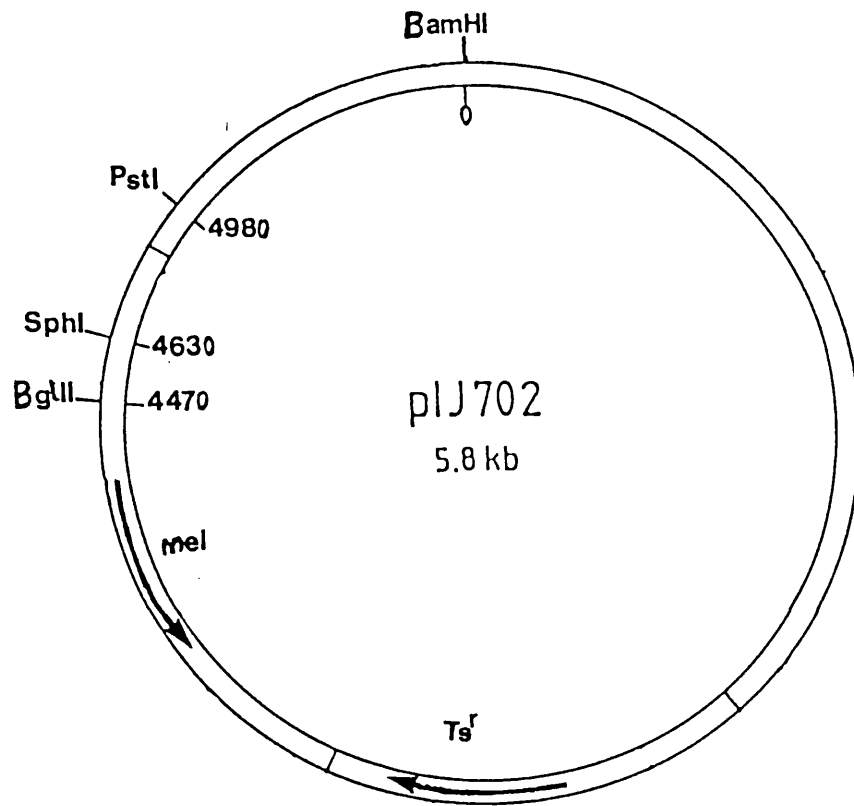

Appendix 5

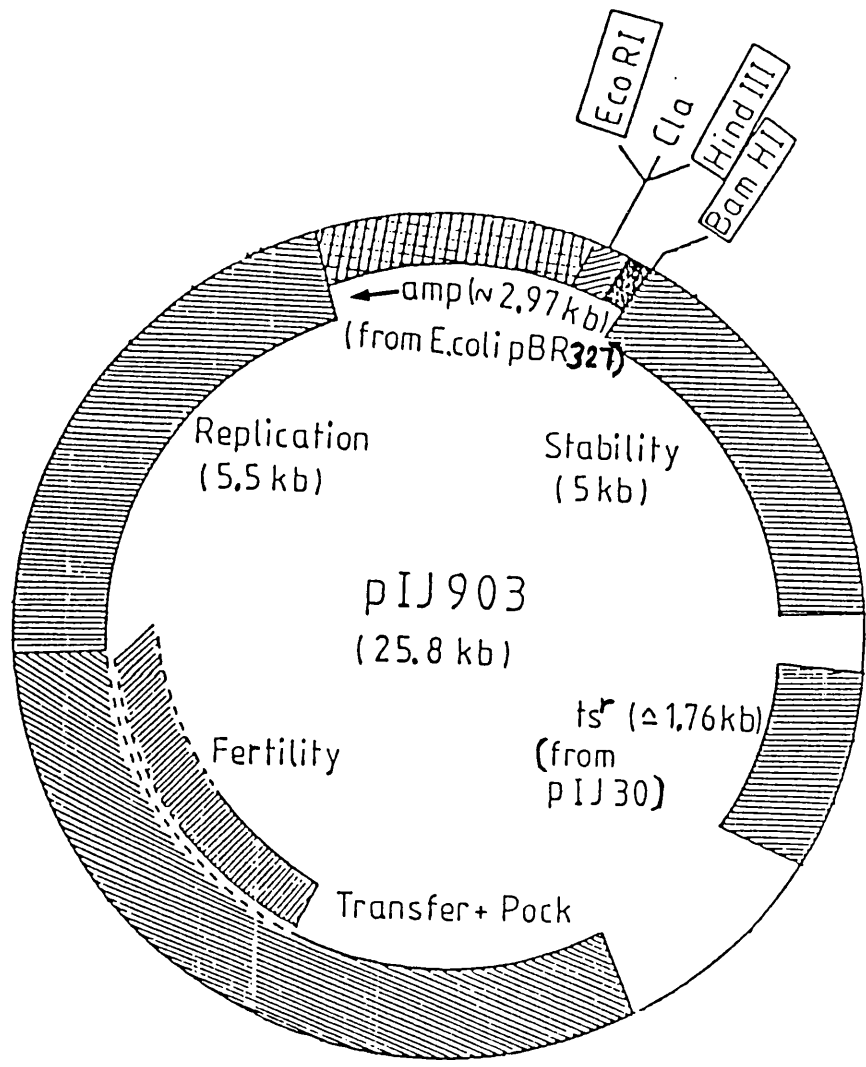

Cloning and expression of an α -amylase gene from *Streptomyces thermoviolaceus* CUB74 in *Escherichia coli* JM107 and *S. lividans* TK24

SAMI M. BAHRI* and JOHN M. WARD

Biochemistry Department, University College London, Gower Street, London WC1E 6BT, UK

(Received 7 August 1989; revised 14 November 1989; accepted 15 January 1990)

A gene coding for a thermostable extracellular α -amylase, carried by a 5.7 kb *Bam*HI chromosomal DNA fragment isolated from *Streptomyces thermoviolaceus* strain CUB74, was cloned into *Escherichia coli* JM107 using, as a cloning vector, the high-copy-number plasmid pUC8. *E. coli* containing a recombinant plasmid pQR300 expressed the amylase gene and exported the enzyme into the periplasmic space and the culture medium. The amylase protein expressed by *E. coli* had the same molecular mass (50 kDa) as that expressed by the *Streptomyces* parent strain, which suggests that the enzyme is processed similarly by both strains. The amylase gene was also cloned into *Streptomyces lividans* TK24 using pIJ702 as vector. The enzyme was stable at 70 °C when CaCl₂ was present.

Introduction

α -Amylases are secreted endoenzymes that randomly cleave $\alpha(1,4)$ linkages in starch, generating shorter chains of glucose units which can eventually be taken up and utilized by many organisms. α -Amylase is found widely amongst *Streptomyces* species. Recently, α -amylases have been isolated and characterized from *Streptomyces hygrosopicus*, *S. venezuelae*, and *S. limosus*. *S. hygrosopicus* SF-1084 produces an extracellular α -amylase which is used industrially to hydrolyse starch to maltose. The gene specifying the enzyme has been isolated and sequenced (Hoshiko *et al.*, 1987; McKillop *et al.*, 1986). The amylase gene of *S. limosus* has also been isolated and sequenced. Its amino acid sequence showed regions with up to 80% homology to mammalian and invertebrate α -amylases (Long *et al.*, 1987) but not to other bacterial, fungal or plant α -amylases. The gene for an α -amylase from *S. venezuelae* has recently been cloned and characterized (Virolle *et al.*, 1988). The predicted amino acid sequence of this enzyme shows 75% identity with the *S. limosus* α -amylase.

High hydrolysis temperatures are desirable in the starch industry because starch granules cannot be attacked by α -amylase unless they have been ruptured by heat (gelatinization). Since the enzymes of thermophilic bacteria are generally heat-stable (Ljungdahl, 1979), we are investigating amylases produced by thermophilic *Streptomyces* strains.

Cloning and expression of *Streptomyces* genes have been mostly carried out within *Streptomyces* (Bibb *et al.*, 1983). However, a few examples of expression of cloned *Streptomyces* genes in *Escherichia coli* have been reported. These include genes for antibiotic resistance (e.g. Vara *et al.*, 1985; Gil *et al.*, 1985; Schupp *et al.*, 1983), a gene for an extracellular endoglycosidase H (Robbins *et al.*, 1981), and a few examples of genes for biosynthetic enzymes (Meade, 1985; Hercomb *et al.*, 1987).

In this paper, we report the isolation of an α -amylase gene from a thermophilic streptomycete, *S. thermoviolaceus* strain CUB74, and its cloning and expression in *E. coli* and *S. lividans*.

Methods

Bacterial strains and plasmids. The characteristics of *E. coli* JM107 and *S. lividans* TK24 are shown in Table 1. *S. thermoviolaceus* strain CUB74 was obtained from Dr A. McCarthy (University of Liverpool, UK). Plasmids pUC8, 18 and 19 were used for cloning in *E. coli* whereas pQR1 (R. Barallon & J. M. Ward, unpublished) and pIJ903 (Lydiat *et al.*, 1985) were used as shuttle vectors for cloning in both *E. coli* and *Streptomyces* strains. pQR1 was constructed by ligating pBR325 and pIJ702 that had been digested with *Pst*I. pIJ702 was also used for cloning in *S. lividans*.

Culture media and antibiotics. *E. coli* strains were grown at 37 °C in nutrient broth (Oxoid) or on nutrient agar (Oxoid nutrient broth solidified with 2%, w/v; Difco agar); both media were supplemented with ampicillin (500 μ g ml⁻¹), IPTG (40 μ g ml⁻¹), X-gal (80 μ g ml⁻¹) and potato starch (1%, w/v; Sigma, type S-4251) when necessary. *S.*

Table 1. *Bacteria and plasmids*

Bacterial strain or plasmid	Genotype or relevant characteristics	Reference
<i>E. coli</i> JM107	<i>endA1 gyrA96 thi-1 hsdR17 supE44 relA1 Δ(lac-proAB) (F' traD36, proAB, lacI^qZΔM15)</i>	Yanisch-Perron <i>et al.</i> (1985)
<i>S. lividans</i> TK24	Str-6, SLP2 ⁻ SLP3 ⁻	Hopwood <i>et al.</i> (1983)
pUC8, pUC18, pUC19	Ap ^r , <i>lacZα</i>	Vieira & Messing (1982)
pQR1	pIJ702/pBR325 hybrid; Ts ^r Cm ^r Tc ^r	R. Barallon & J. M. Ward, unpublished
pIJ702	Ts ^r Mel ⁺	Katz <i>et al.</i> (1983)
pIJ903	Ts ^r Ap ^r	Lydiate <i>et al.</i> (1985)

thermoviolaceus CUB74 was grown at 50 °C in half-strength nutrient broth or on half-strength nutrient agar; *S. lividans* TK24 was grown on R2YE (solid) or YEME (liquid) media with and without sucrose (Hopwood *et al.*, 1985). These media were supplemented with 1% (w/v) potato starch in order to visualize any amylase activity on plates, and thiostrepton (50 µg ml⁻¹) was added when required.

Isolation of total DNA and plasmids. Total DNA was prepared by a slightly modified method of that described by Chater *et al.* (1982). Mycelia, harvested from an overnight liquid culture of CUB74, were resuspended in 20 ml Birnboim buffer (25 mM-Tris/HCl, pH 7.5, 10 mM-Na₂EDTA, 0.9% w/v, glucose, 2 mg lysozyme ml⁻¹). After adding SDS to a final concentration of 1% (w/v), 4 ml pronase solution (10 mg ml⁻¹; pre-self-digested at 37 °C for 2 h) was mixed with the preparation. This was then mixed with 4 ml TE buffer (10 mM-Tris/HCl, pH 7.5, 1 mM-EDTA) plus RNAase (20 µg ml⁻¹) and incubated at 37 °C for 1 h. Then 5 ml of the same buffer was added and incubation was continued for a further 2 h at the same temperature. Finally, 1 ml 5 M-NaCl was added, 20 ml of ethanol was layered on and the DNA was spooled with a flame-blunted Pasteur pipette. The DNA was resuspended in 18 ml TE buffer and purified on a caesium chloride/ethidium bromide gradient if necessary.

Plasmid isolation on a large scale was done by the method of Bibb *et al.* (1977). Small-scale preparation of plasmid DNA was performed as described by Birnboim & Doly (1979).

Cloning and expression of the amylase gene in *E. coli*. All restriction endonuclease digestions and ligations were performed as described by Maniatis *et al.* (1982). Agarose gels (1%, w/v) were used to separate the DNA bands.

Chromosomal DNA of *S. thermoviolaceus* CUB74 was digested to completion with *Bam*HI and ligated to pUC8 that had been cut with the same restriction enzyme. The genomic library was then used to transform competent *E. coli* JM107. All ampicillin-resistant (Ap^r) colonies obtained were replicated on to starch plates using sterile velvet pads.

Restriction endonuclease mapping and subcloning. The following restriction endonucleases were used: *Eco*RI, *Hind*III, *Bam*HI, *Pst*I, *Bgl*II, *Xho*I, *Sph*I, *Kpn*I, *Sma*I, *Sal*GI, *Bcl*II and *Sac*I. λ DNA digested with *Hind*III was used as a size marker. The map of the insert is shown in Fig. 1. In order to locate the amylase gene (*amy*) on the insert, pQR300 (pUC8 plus insert) was double digested to completion with *Bam*HI/*Bgl*II, extracted with phenol/chloroform and then religated. For the same purpose, the 1.7 kb *Bam*HI-*Sph*I fragment was extracted from an agarose gel (Girvitz *et al.*, 1980) and cloned into pUC18 that had been cut with the same restriction enzymes. In addition, and in order to determine whether the amylase gene is expressed from the *lacZ* promoter on pUC8 or from its own promoter, cloning of the whole

insert in the opposite orientation to the *lacZ* promoter was performed by digesting pQR300 with *Bam*HI and religating it. The orientation of the insert was determined by isolating and mapping plasmids from both amylase-negative and amylase-positive colonies. For the same purpose, the whole insert was subcloned in the *Bgl*II site of pQR1, which lacks the *lacZ* promoter.

For the cloning and expression in *S. lividans*, the amylase gene carried by the 5.7 kb *Bam*HI fragment was cloned into the shuttle vector pQR1 that had been cut with *Bgl*II. Recombinant plasmids (pQR308 and pQR309) were isolated from *E. coli* and used to transform *S. lividans*. The high-copy-number streptomycete vector pIJ702 was also used for subcloning. The plasmid was cut with *Bgl*II and *Sph*I and ligated to the 1.7 kb *Bam*HI-*Sph*I DNA fragment carrying the amylase gene. The recombinant plasmid construct obtained was called pQR311. The low-copy-number plasmid pIJ903 was also used for cloning in both *E. coli* and *S. lividans*. A 1.7 kb *Bam*HI-*Hind*III DNA fragment from pQR307, generated by partial *Hind*III digestion and complete *Bam*HI digestion, was inserted between the *Bam*HI and *Hind*III sites of pIJ903. The resulting plasmid was called pQR319.

Preparation of *S. lividans* protoplasts and their transformation were performed as described by Hopwood *et al.* (1985).

Preparation of enzyme, protein determination and SDS-PAGE. Total extracellular enzymes (concentrated 100-fold) were prepared from *E. coli* and *Streptomyces* cultures by precipitating with ammonium sulphate (90% saturation). The precipitate was resuspended in 20 mM-Tris/HCl, pH 7.5, 5 mM CaCl₂, dialysed twice (1 h each) against the same buffer at room temperature and once overnight against the same buffer containing 50% (v/v) glycerol at 4 °C, and finally stored at -20 °C.

The Bio-Rad Protein Assay was used to determine the protein concentration as described by the supplier. Approximately 80–100 µg of protein was subjected to 10% SDS-PAGE (Fig. 2) for molecular mass determination (Laemmli, 1970). The proteins were denatured by mixing with 50 µl loading buffer (5% v/v, mercaptoethanol, 3.4% w/v, SDS, 15% v/v, glycerol, 0.01% w/v, bromophenol blue, 47 mM-Tris/HCl, pH 6.8) and boiling at 100 °C for 3 min, and were run in duplicate. They were renatured by washing half the gel twice with 2.5% (w/v) Triton X-100, 1 h each, and then rinsing it in 20 mM-Tris/HCl, pH 7.5, 5 mM-CaCl₂ for 25 min at room temperature. The position of the enzyme activity was located by sandwiching the reactivated gel against a 1% (w/v) agarose gel made in the Tris/HCl buffer and containing 0.5% potato starch. The sandwich was incubated overnight at 37 °C between two glass plates and under a weight. Starch hydrolysis zones were detected by soaking the agarose gel in 0.05% (w/v) I₂, 2.65% (w/v) KI (Siggins, 1987). The other half of the protein gel also contained molecular mass markers (from Sigma) and was stained with Coomassie Brilliant Blue R.

Amylase assay and paper chromatography. Enzyme units were calculated by carrying out a modified Somogyi assay (Nelson, 1944) in which 500 μ l of an enzyme preparation was mixed with 500 μ l of 1% (w/v) soluble starch (in the same Tris/HCl buffer plus 5 mM-CaCl₂). After 1 h incubation at 50 °C, 100 μ l was removed from the mixture and added to 900 μ l of distilled water. Then 1 ml of a mixture of reagent A and reagent B as specified by Nelson (1944) was added and mixed. The mixture was heated at 100 °C for 20 min, cooled and 1 ml of the arsenomolybdate reagent was added. After complete evolution of CO₂, the mixture was added to 10 ml distilled water and the absorbance read at 600 nm. One unit of amylase was defined as the amount of enzyme which releases 1 mg reducing sugar from soluble starch in 1 h at 50 °C and pH 7.5. A standard curve was made using maltose.

The product of starch hydrolysis by amylase was analysed by paper chromatography using 2-propanol/water (7:3, v/v) as solvent and silver nitrate as a stain (Robyt & French, 1963).

Results

Cloning and expression of the amylase gene in *E. coli*

Transformation of *E. coli* JM107 by the *Bam*HI library of *S. thermoviolaceus* CUB74 DNA in pUC8 resulted in more than 10000 Ap^r colonies, 64% of which were colourless on X-gal plates and presumed to be recombinants. After replicating on starch plates, one colony showed extensive amylase activity and a zone of starch hydrolysis was observed with or without iodine staining. This amylase-positive colony was found to have a recombinant plasmid, pQR300, containing an insert of 5.7 kb (Fig. 1). pQR300 was used to transform *E. coli* and 100% of the colonies obtained were amylase positive. On starch plates, pUC8-containing *E. coli* colonies (control) produced no hydrolysis zones. Approximately 40% of the amylase activity expressed by *E. coli* JM107(pQR300) was present in the culture supernatant (extracellular fraction); the remainder (60%) was located in the periplasm/cytoplasmic fraction (Table 2). Alkaline phosphatase was used as a periplasmic marker.

Surprisingly, IPTG, added to liquid medium, induced the amylase production by *E. coli* JM107(pQR300) but not substantially (by 16% only); on plates, larger hydrolysis zones were obtained in the presence of IPTG. Transformation of *E. coli* JM107 with pQR303 (Fig. 1), where the 5.7 kb *Bam*HI fragment was cloned in the opposite orientation to the *lacZ* promoter, yielded amylase-negative colonies only. Furthermore, cloning of the 5.7 kb *Bam*HI fragment into the *Bgl*III site of pQR1 to give the plasmids pQR308 and pQR309 resulted in amylase-negative *E. coli* colonies. The *Bgl*III site is in the *mel* operon, which is not expressed in *E. coli*. It was therefore concluded that the expression of the amylase gene was from the *lacZ* promoter in the pUC8 derivatives and not from its own promoter. The low level of induction by IPTG may be explained by the high copy

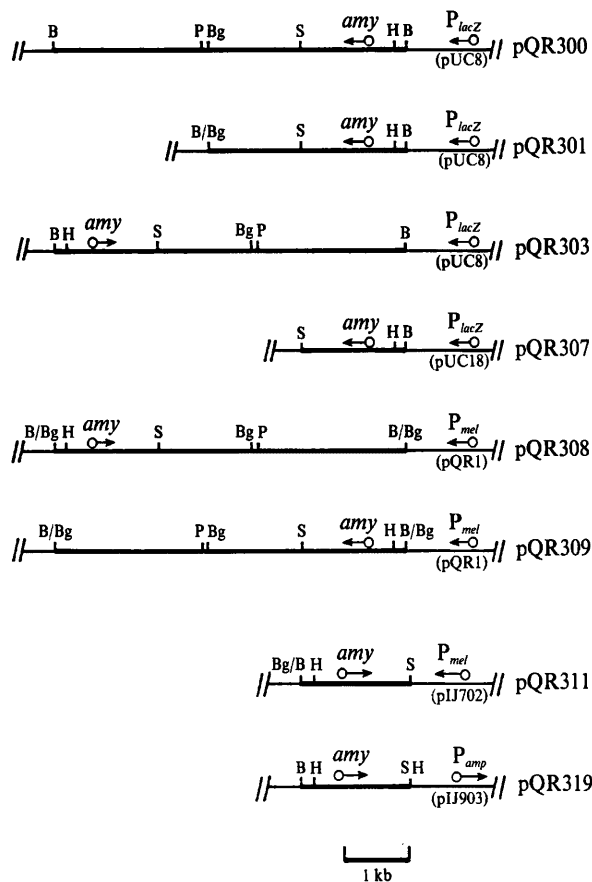

Fig. 1. Restriction enzyme map of pQR300 and plasmids obtained from subcloning experiments. The construction of these plasmids is described in Methods. The arrows represent the orientation of the amylase gene (*amy*) in relation to the *lacZ* promoter P_{lacZ} on pUC8 and pUC18, the *mel* promoter (P_{mel}) on pQR1 and pIJ702 (in the case of pQR308, pQR309 and pQR311), and the ampicillin promoter (P_{amp}) on pIJ903 (in the case of pQR319). B, *Bam*HI; P, *Pst*I; Bg, *Bgl*III; S, *Sph*I; H, *Hind*III.

number of the plasmid, which titrates out a proportion of the *lacI* repressor even in strains containing the *lacI*^q allele (Stewart *et al.*, 1986).

The *Streptomyces* origin of the amylase gene was confirmed by probing a *Bam*HI bulk digestion of *S. thermoviolaceus* CUB74 total DNA (Southern, 1975) with radioactively labelled pQR300 (data not shown). A single 5.7 kb *Bam*HI fragment of CUB74 showed homology with the probe.

Mapping and subcloning

The map of the insert and the plasmids resulting from subcloning are shown in Fig. 1. It was found that the amylase gene is carried by a 1.7 kb *Bam*HI-*Sph*I fragment (pQR307) and starts from the side of the *Bam*HI site as deduced from the lack of α -amylase expression from *E. coli* harbouring pQR303. Plasmids

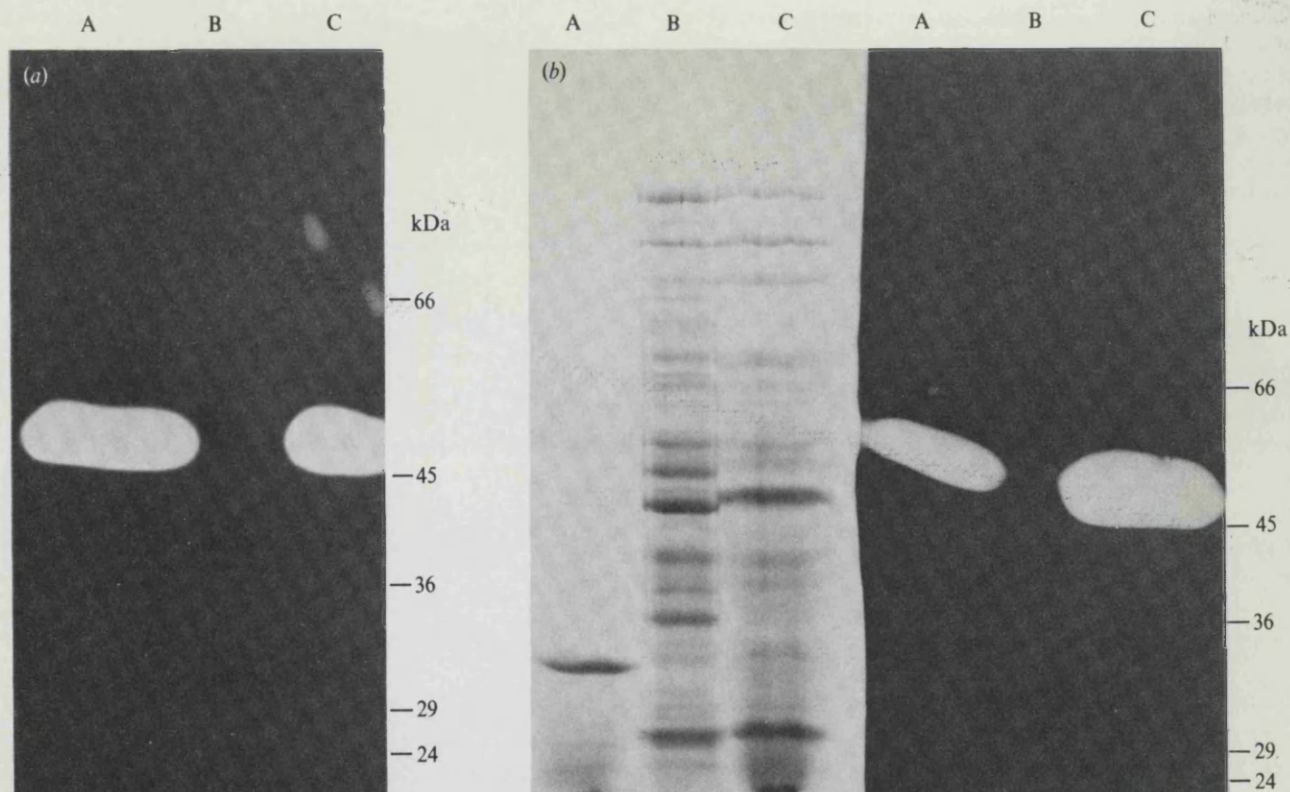

Fig. 2. SDS-PAGE. Approximately 80 μ g of *E. coli* and *S. thermoviolaceus* CUB74 crude supernatants (concentrated 100-fold) and 100 μ g of *S. lividans* supernatants were loaded on the gel. Protein samples were run in duplicate on the same gel. An agarose gel containing potato starch was overlaid on the reactivated half of the protein gel and stained with iodine as described in Methods. The other half of the gel, which also contained molecular mass markers, was stained with Coomassie Brilliant Blue R. (a) (Activity stain only): A, *E. coli* JM107(pQR300); B, *E. coli* JM107(pUC8) (control); C, *S. thermoviolaceus* CUB74. (b) A, *S. thermoviolaceus* CUB74, B, *S. lividans* TK24(pIJ702) (control); C, *S. lividans* TK24(pQR311). The molecular mass markers were bovine serum albumin (66 kDa), egg albumin (45 kDa) glyceraldehyde-3-phosphate dehydrogenase (36 kDa), carbonic anhydrase (29 kDa) and trypsinogen, PMSF treated (24 kDa).

Table 2. Localization of amylase expressed by *E. coli* JM107(pQR300)

E. coli JM107(pQR300) was grown in the low-phosphate medium of Neu & Heppel (1964) to an OD_{450} of 1.0 and fractionated by the method of Minton *et al.* (1983). Alkaline phosphatase was assayed by the method of Torriani (1966); amylase was assayed as described in Methods. This experiment was repeated three times and the results obtained were consistent, varying by only 3–5%.

Fraction	Percentage of enzyme activity	
	Alkaline phosphatase	Amylase
Supernatant	9	43.2
Periplasm/cytoplasm	91	56.8
Membrane bound	0	0

pQR308 and pQR309 isolated from *E. coli* were used to transform *S. lividans* TK24 and thiostrepton-resistant (Ts^r) colonies were selected. These plasmid constructs

(pQR308 and 309) were extremely unstable in *S. lividans*. They rearranged and lost the amylase gene.

Cloning in *S. lividans* was successful when the *Bam*HI–*Sph*I fragment carrying the amylase gene was inserted into the high-copy-number plasmid pIJ702 which had been cut with *Bgl*II/*Sph*I and $Mel^- Ts^r$ colonies were selected for. The recombinant plasmid was designated pQR311. Large amylase zones were produced by *S. lividans* TK24(pQR311) colonies whereas the control, TK24(pIJ702), produced small zones. The 1.7 kb *Bam*HI–*Sph*I fragment was also subcloned into the low-copy-number plasmid pIJ903 and the recombinant plasmid (pQR319) was introduced to *E. coli* and *S. lividans*. *E. coli* colonies containing this construct were amylase negative whereas *S. lividans* containing the construct produced large amylase zones on starch plates.

SDS-PAGE and characterization of amylase

Concentrated crude culture supernatants of *E. coli* and *S. thermoviolaceus* CUB74 were analysed on the same

gel (Fig. 2a). *E. coli* JM107(pQR300) (lane A) and *S. thermoviolaceus* CUB74 (lane C) showed a starch-degrading activity corresponding to a protein of the same size (50 kDa) after renaturation of the proteins in the SDS polyacrylamide gel. This similarity in molecular mass suggests that *E. coli* can correctly process the amylase protein to the form found in the parent *Streptomyces* strain. Coomassie staining of protein bands in the gel (results not shown) revealed comigration of the amylases from *E. coli* JM107(pQR300) and *S. thermoviolaceus* CUB74, showing that the processing of the signal peptide by *E. coli* could differ by no more than a few amino acids. This preliminary result is currently being resolved by sequencing the N-terminus of both proteins. There was no detectable amylase activity from the pUC8-containing *E. coli* control (Fig. 2a, lane B).

The amylase produced by pQR311-containing *S. lividans* also had the same size as that of CUB74, and no amylase activity was detectable in the reactivated gel system from pIJ702-containing *S. lividans* (Fig. 2b).

Paper chromatography analysis

Paper chromatography of starch digestion products showed that maltose was the major end-product and started to appear as a distinct spot at 1.5 h. Glucose, however, appeared in small amounts at 8 h. From this result, it was concluded that the enzyme is an α -amylase as the major products are maltotetraose, maltotriose and maltose, with maltose accumulating over extended periods while maltotetraose disappears.

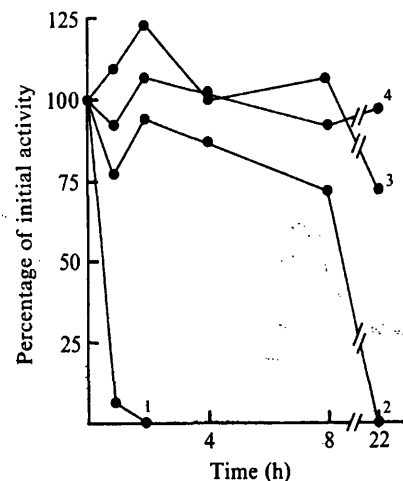

Fig. 3. Effect of Ca^{2+} on heat stability of the enzyme. Cultures (5 ml) of *E. coli* JM107(pQR300) were grown overnight at 37 °C in nutrient broth with and without 5 mM- CaCl_2 . Samples (500 μl) of their supernatants were preincubated at 50 or 60 °C for the time indicated and then assayed at 50 °C. The 1% soluble starch solution used in this assay was made up in 20 mM-Tris/HCl pH 7.5 buffer plus 5 mM- CaCl_2 . 1, In the absence of CaCl_2 and at 60 °C; 2, in the absence of CaCl_2 and at 50 °C; 3, in the presence of CaCl_2 and at 60 °C; 4, in the presence of CaCl_2 and at 50 °C. These experiments have been repeated and the results are reproducible.

Temperature stability

The temperature stability of the enzyme was examined in the presence and absence of CaCl_2 by preincubating in the absence of substrate. In the presence of 5 mM- CaCl_2 , the amylase secreted by *E. coli* JM107(pQR300) retained

Table 3. Effect of temperature on enzyme activity

E. coli JM107(pQR300) was grown with and without 5 mM- CaCl_2 overnight at 37 °C. Samples (500 μl) of each culture supernatant were preincubated at the temperature indicated for 1 h and then assayed at 50 °C as described in Methods. The 1% soluble starch used in the enzyme assay was made up in 20 mM-Tris/HCl buffer pH 7.5 plus 5 mM- CaCl_2 . This experiment has been repeated three times and the results were within 4% of those shown below.

Temp. (°C)	Minus CaCl_2		Plus CaCl_2	
	Activity (U ml ⁻¹)	Percentage of max. activity	Activity (U ml ⁻¹)	Percentage of max. activity
4	3.62	88	2.5	88
37	4.1	100	2.84	100
50	3.64	89	2.58	90
60	0.62	15	2.52	89
70	0.52	13	2	70
80	0.1	2	0.3	11

90% of its activity at 60 °C and 70% of its activity at 70 °C after preincubation for 1 h at these temperatures (Table 3). Most of this activity was abolished above 80 °C. In the absence of CaCl₂, the amylase activity rapidly fell at temperatures above 50 °C. Fig. 3 shows that in the absence of CaCl₂, the enzyme lost 30% of its activity after 8 h incubation at 50 °C and it was totally inactive after 22 h at 50 °C and 2 h at 60 °C. It also shows that in presence of CaCl₂, the enzyme was 100% stable after 22 h incubation at 50 °C and 8 h at 60 °C.

Discussion

The α -amylase gene of *S. thermophilaceus* CUB74 has been cloned and expressed in *E. coli* and more than 40% of its product was secreted into the medium. It is the exception rather than the rule for enzymes which are extracellular in their original Gram-positive host to be exported into the culture medium when cloned in *E. coli*. In most cases, Gram-positive extracellular enzymes are periplasmic when expressed in *E. coli* (Pugsley, 1988). It is not clear at this stage whether any other protein(s) beside the α -amylase are required for the extracellular location in *E. coli*. The smallest insert still expressing amylase is 1.7 kb. DNA sequencing of this and further subcloning will reveal whether all the information for secretion beyond the periplasmic space is located in the coding sequence of the *amy* gene.

The expression of *amy* in *E. coli* was not observed when the insert was subcloned either in the opposite orientation to the *lacZ* promoter or in a vector that lacks this promoter (pQR1). This barrier to expression of *Streptomyces* genes in *E. coli* has been previously observed (Horinouchi *et al.*, 1980; Bibb & Cohen, 1982; Rodgers *et al.*, 1982). On the other hand, while the expression of amylase seemed to be possibly from the *lacZ* promoter, its production was not substantially induced by IPTG. This, in theory, might be a result of the high-copy-number of the plasmid, which may titrate out the *lacI* repressor. Hoshiko *et al.* (1987) reported the induction, in *E. coli*, of *S. hygroscopicus* α -amylase. They found that the enzyme, whose gene had been cloned in pUC12, was induced approximately sevenfold in the presence of IPTG.

The molecular mass of the secreted α -amylase of CUB74 determined by SDS-PAGE was 50 kDa, which, within the errors of the method, is the same as that of the enzyme secreted by *E. coli* and *S. lividans*. This similarity may result from the ability of *E. coli* to process the signal peptide correctly as in the original *Streptomyces* host. This result can only be proven by sequencing the N-terminus of the secreted enzyme from both strains. It is

not a general case that *E. coli* will process the signal peptide in exactly the same manner as a Gram-positive organism: e.g. the endo- β -*N*-acetylglucosidase H in its natural host, *S. plicatus*, is smaller than when it is expressed by *E. coli* (Robbins *et al.*, 1981); it was therefore suggested that a secondary cleavage, which occurs in Gram-positive secreted proteins, does not occur when the protein is synthesized and secreted into the periplasmic space by *E. coli* (Robbins *et al.*, 1984). In our experiments, the *S. thermophilaceus* amylase was secreted into the culture medium of *E. coli* cells containing pQR300 under conditions where alkaline phosphatase, a periplasmic enzyme, was still retained up to 91% in the periplasm/cytoplasmic fraction (Table 2). This implies a specific release of the amylase into the medium rather than a non-specific release of periplasmic proteins as has been seen when there is overproduction of periplasmic proteins (Suominen *et al.*, 1987).

In order to study the expression of amylase in *S. lividans*, low (pIJ903) (Lydiat *et al.*, 1985) and high (pQR1) copy-number shuttle vectors were used. When the *Bgl*II site of pQR1 was used for cloning, the resulting plasmid constructs (pQR308 and 309) were stable in *E. coli*. However, they were very unstable in *S. lividans* and underwent large deletions which removed the cloned DNA and a part of the vector. Similar problems were also encountered when the 5.7 kb *Bam*HI fragment was inserted in the *Bgl*II site of pIJ702. This could be due to the presence of unstable sequences carried by the insert. This was avoided by cloning a smaller DNA fragment, a 1.7 kb *Bam*HI-*Sph*I fragment, in pIJ702. The recombinant plasmid construct pQR311 was stable and expression of the amylase gene was obtained. Our results strongly suggest that the amylase gene is transcribed in the direction of *Bam*HI to *Sph*I in the 1.7 kb fragment inserted into pIJ702. This would place the amylase gene in the opposite orientation with respect to the *mel* promoter of pIJ702 in pQR311. It is not known yet whether the 1.7 kb fragment contains the promoter of the amylase gene or whether expression in *S. lividans* is caused by readthrough from promoters within the vector.

The activity expressed by the cloned α -amylase gene in *E. coli* has a surprisingly extended stability in the presence of Ca²⁺. At 50 °C, 100% of the starting activity remained after 22 h (Fig. 3). At 60 °C, this had only dropped to 75% after 22 h. From the data shown in Table 3, 70% of the starting activity remained after 1 h at 70 °C in the presence of Ca²⁺. The presence of Ca²⁺ therefore substantially increases the stability to thermal denaturation. The effect of Ca²⁺ on the thermal stability of several extracellular proteins is well known: for example many extracellular enzymes from *Bacillus* species are stabilized by binding Ca²⁺ (Normen, 1979).

The stability of the α -amylase in the presence of substrate has not been extensively tested but preliminary results (data not shown) suggest an even greater stability in the presence of starch and Ca^{2+} than for Ca^{2+} alone. This enzyme may be a candidate for constructing promoter-probe vectors or for protein fusion studies since it is easily assayed and its expression leads to the appearance of zones around colonies on starch plates even before staining with iodine. It is expressed in *E. coli* and secreted in high amounts into the culture medium. This makes its isolation easy since it avoids problems associated with cell breakage. Furthermore, the enzyme assay can be carried out at a high temperature, 60–70 °C, which eliminates background caused by any amylase activity of a mesophilic host, e.g. *S. lividans*.

This work was supported by a grant from the Hariri Foundation to S. M. B. and by a grant from the SERC Biotechnology Directorate to J. M. W. We thank R. Barallon for supplying pQR1. Thiostrepton was a generous gift of S. J. Lucania. The Squibb Institute for Medical Research, New Jersey.

References

- BIBB, M. J. & COHEN, S. N. (1982). Gene expression in *Streptomyces*: construction and application of promoter-probe plasmid vectors in *Streptomyces lividans*. *Molecular and General Genetics* **187**, 265–277.
- BIBB, M. J., FREEMAN, R. F. & HOPWOOD, D. A. (1977). Physical and genetical characterization of a second sex factor, SCP2, for *Streptomyces coelicolor* A3(2). *Molecular and General Genetics* **154**, 155–166.
- BIBB, M. J., CHATER, K. F. & HOPWOOD, D. A. (1983). Developments in *Streptomyces* cloning. In *Experimental Manipulation of Gene Expression*, pp. 54–80. Edited by M. Inouye. London: Academic Press.
- BIRNBOIM, H. C. & DOLY, J. (1979). A rapid alkaline extraction procedure for screening recombinant plasmid DNA. *Nucleic Acids Research* **7**, 1513–1523.
- CHATER, K. F., HOPWOOD, D. A., KIESER, T. & THOMPSON, C. J. (1982). Gene cloning in *Streptomyces*. *Current Topics in Microbiology and Immunology* **97**, 69–95.
- GIL, J. A., KIESER, H. M. & HOPWOOD, D. A. (1985). Cloning of a chloramphenicol acetyltransferase gene of *Streptomyces acrimycini* and its expression in *Streptomyces* and *Escherichia coli*. *Gene* **38**, 1–8.
- GIRVITZ, S. C., BACCHETTI, S., RAINBOW, J. A. & GRAHAM, L. F. (1980). A rapid and efficient procedure for the purification of DNA from agarose gels. *Analytical Biochemistry* **106**, 492.
- HERCOMB, J., THIERBACH, G., BAUMBERG, S. & PARISH, J. H. (1987). Cloning, characterization and expression in *Escherichia coli* of a leucine biosynthetic gene from *Streptomyces rochei*. *Journal of General Microbiology* **133**, 317–322.
- HOPWOOD, D. A., KEISER, T., WRIGHT, M. H. & BIBB, M. J. (1983). Plasmids, recombination and chromosome mapping in *Streptomyces lividans* 66. *Journal of General Microbiology* **129**, 2257–2269.
- HOPWOOD, D. A., BIBB, M. J., CHATER, K. F., KIESER, T., BRUTON, C. J., KIESER, H. M., LYDIATE, D. J., SMITH, C. P., WARD, J. M. & SCHREMPF, H. (editors) (1985). *Genetic Manipulation of Streptomyces: A Laboratory Manual*. Norwich: The John Innes Foundation.
- HORINOUCI, S., UOZUMI, T. & BEPPU, T. (1980). Cloning of *Streptomyces* DNA into *Escherichia coli*; absence of heterospecific gene expression of *Streptomyces* genes in *Escherichia coli*. *Agricultural and Biological Chemistry* **44**, 367–371.
- HOSHIKO, S., MAKABE, O., NOJIRI, C., KATSUMATA, K., SATOH, E. & NAGAOKA, K. (1987). Molecular cloning and characterization of the *Streptomyces hygroscopicus* α -amylase gene. *Journal of Bacteriology* **169**, 1029–1036.
- KATZ, F., THOMPSON, C. J. & HOPWOOD, D. A. (1983). Cloning and expression of the tyrosinase gene from *Streptomyces antibioticus* in *Streptomyces lividans*. *Journal of General Microbiology* **129**, 2703–2714.
- LAEMMLI, U. K. (1970). Cleavage of structural proteins during the assembly of the head of bacteriophage T4. *Nature, London* **227**, 680–685.
- LJUNGDAHL, L. G. (1979). Physiology of thermophilic bacteria. *Advances in Microbial Physiology* **19**, 149–243.
- LONG, C. M., VIROLLE, M.-J., CHANG, S. & BIBB, M. J. (1987). α -Amylase gene of *Streptomyces limosus*: nucleotide sequence, expression motifs and amino acid sequence homology to mammalian and invertebrate α -amylase. *Journal of Bacteriology* **169**, 5745–5754.
- LYDIATE, D. J., MALPARTIDA, F. & HOPWOOD, D. A. (1985). The *Streptomyces* plasmid SCP2*: its functional analysis and development into useful cloning vectors. *Gene* **35**, 223–235.
- MANIATIS, T., FRITSCH, E. F. & SAMBROOK, J. (editors) (1982). *Molecular Cloning: A Laboratory Manual*. Cold Spring Harbor, NY: Cold Spring Harbor Laboratory.
- MCKILLOP, C., ELVIN, P. & KENTEN, J. (1986). Cloning and expression of an extracellular α -amylase gene from *Streptomyces hygroscopicus* in *Streptomyces lividans* 66. *FEMS Microbiology Letters* **36**, 3–7.
- MEADE, H. (1985). Cloning of *argG* from *Streptomyces*: loss of gene in Arg^- mutants of *Streptomyces cattleya*. *Biotechnology* **3**, 917–918.
- MINTON, N. P., ATKINSON, T. & SHERWOOD, R. F. (1983). Molecular cloning of the *Pseudomonas* carboxypeptidase G₂ gene and its expression in *Escherichia coli* and *Pseudomonas putida*. *Journal of Bacteriology* **156**, 1222–1227.
- NELSON, N. (1944). A photometric adaptation of the Somogyi method for the determination of glucose. *Journal of Biological Chemistry* **153**, 375–380.
- NEU, H. C. & HEPPPEL, L. A. (1964). The release of enzymes from *Escherichia coli* by osmotic shock and during the formation of spheroplasts. *Journal of Biological Chemistry* **240**, 3685–3692.
- NORMEN, B. E. (1979). The application of polysaccharide degrading enzymes in the starch industry. In *Microbial Polysaccharides and Polysaccharases*, pp. 338–376. Edited by R. C. W. Berkeley, G. W. Gooday & D. C. Ellwood. London: Academic Press.
- PUGSLEY, A. P. (1988). Getting out of *Escherichia coli*: protein secretion across the Gram-negative outer membrane. In *Protein Transfer and Organelle Biogenesis*, pp. 607–652. Edited by R. C. Das & P. W. Robbins. London: Academic Press.
- ROBBINS, P. W., WIRTH, D. F. & HERING, C. (1981). Expression of the *Streptomyces* enzyme endoglycosidase H in *Escherichia coli*. *Journal of Biological Chemistry* **256**, 10640–10644.
- ROBBINS, P. W., TRIMBLE, R., WIRTH, D. F., HERING, C., MALEY, F., MALEY, G., DAS, R., GILSON, B. W., ROYAL, N. & BIEMAN, K. (1984). Primary structure of *Streptomyces* enzyme endo- β -N-acetylglucosamidase H. *Journal of Biological Chemistry* **259**, 7577–7583.
- ROBYT, J. & FRENCH, D. (1963). Action pattern and specificity of an amylase from *Bacillus subtilis*. *Archives of Biochemistry and Biophysics* **100**, 451–467.
- RODGERS, W. H., SPRINGER, W. & YOUNG, F. E. (1982). Cloning and expression of *Streptomyces fradiae* neomycin resistance gene in *Escherichia coli*. *Gene* **18**, 133–141.
- SCHUPP, T., TOUPET, C., STALHAMMER-CARLEMAM, M. & MEYER, J. (1983). Expression of a neomycin phosphotransferase gene from *Streptomyces fradiae* in *Escherichia coli* after interplasmid recombination. *Molecular and General Genetics* **189**, 27–33.
- SIGGENS, K. W. (1987). Molecular cloning and characterization of the beta-amylase gene from *Bacillus circulans*. *Molecular Microbiology* **1**, 86–91.
- SOUTHERN, E. M. (1975). Detection of specific sequences among DNA fragments separated by agarose gel electrophoresis. *Journal of Molecular Biology* **98**, 503–517.
- STEWART, G. S. A. B., CLIVE, S. L.-M., JACKSON, G., CASSEL, A. & KUHN, J. (1986). pHG165: a pBR322 copy number derivative of pUC8 for cloning and expression. *Plasmid* **15**, 172–181.

- SUOMINEN, I., KARP, M., LAHDE, M., KOPIOT, A., GLUMOFF, T., MEYER, P. & MANTSALA, P. (1987). Extracellular production of cloned α -amylase by *Escherichia coli*. *Gene* **61**, 165-176.
- TORRIANI, A. (1966). Alkaline phosphatase from *Escherichia coli*. In *Procedures in Nucleic Acid Research*, pp. 224-235. Edited by G. L. Cantoni & D. R. Davies. New York: Harper & Row.
- VARA, J., MALPARTIDA, F., HOPWOOD, D. A. & JIMENEZ, A. (1985). Cloning and expression of a puromycin *N*-acetyltransferase gene from *Streptomyces alboniger* in *Streptomyces lividans* and *Escherichia coli*. *Gene* **33**, 197-206.
- VIEIRA, J. & MESSING, J. (1982). The pUC plasmids, an M13mp7 derived system for insertion mutagenesis and sequencing with synthetic universal primers. *Gene* **19**, 259-268.
- VIROLLE, M.-J., LONG, C. M., CHANG, S. & BIBB, M. J. (1988). Cloning, characterisation and regulation of an α -amylase gene from *Streptomyces venezuelae*. *Gene* **74**, 321-334.
- YANISCH-PERRON, C., VIEIRA, J. & MESSING, J. (1985). Improved M13 phage cloning vectors and host strains: nucleotide sequences of the M13mp18 and pUC19 vectors. *Gene* **33**, 103-119.