



Hole-making Process and Its impacts on the Fatigue Response of Ti -6Al-4V Aircraft Alloy

Sun, D., Keys, D., Jin, Y., Malinov, S., Zhao, Q., & Qin, X. (2016). Hole-making Process and Its impacts on the Fatigue Response of Ti -6Al-4V Aircraft Alloy. *Procedia CIRP*, 56, 289-292. DOI: 10.1016/j.procir.2016.10.085

Published in:
Procedia CIRP

Document Version:
Publisher's PDF, also known as Version of record

Queen's University Belfast - Research Portal:
[Link to publication record in Queen's University Belfast Research Portal](#)

Publisher rights

Copyright 2016 the authors.

This is an open access article published under a Creative Commons Attribution-NonCommercial-NoDerivs License (<https://creativecommons.org/licenses/by-nc-nd/4.0/>), which permits distribution and reproduction for non-commercial purposes, provided the author and source are cited.

General rights

Copyright for the publications made accessible via the Queen's University Belfast Research Portal is retained by the author(s) and / or other copyright owners and it is a condition of accessing these publications that users recognise and abide by the legal requirements associated with these rights.

Take down policy

The Research Portal is Queen's institutional repository that provides access to Queen's research output. Every effort has been made to ensure that content in the Research Portal does not infringe any person's rights, or applicable UK laws. If you discover content in the Research Portal that you believe breaches copyright or violates any law, please contact openaccess@qub.ac.uk.

9th International Conference on Digital Enterprise Technology - DET 2016 – “Intelligent Manufacturing in the Knowledge Economy Era

Hole-making and Its Impact on the Fatigue Response of Ti-6Al-4V Alloy

Dan Sun^a, Daniel Keys^a, Yan Jin^{a*}, Savko Malinov^a, Qing Zhao^b, Xuda Qin^b

^a*School of Mechanical and Aerospace Engineering, Queen's University Belfast, UK*

^b*Tianjin Key Laboratory of Equipment Design and Manufacturing Technology, Tianjin University, Tianjin City 300072, People's Republic of China*

* Corresponding author. Tel.: +44-2890974102; fax: +44 28 90974148. E-mail address: y.jin@qub.ac.uk

Abstract

In this work, the impact of conventional drilling and helical milling processes on the fatigue response Ti-6Al-4V (grade 5 titanium alloy) has been presented. Results show that the work pieces produced by helical milling has a 119% longer fatigue life compared with the drilled pieces under dry machining condition, and a 96% longer fatigue life for helical milled piece under lubricated condition. The use of cutting fluid has led to longer fatigue lives – 15% longer for drilling and 3% longer for helical milling. Other results such as the machined surface roughness, alloy surface and sub-surface microstructures have also been studied in details.

© 2016 The Authors. Published by Elsevier B.V. This is an open access article under the CC BY-NC-ND license (<http://creativecommons.org/licenses/by-nc-nd/4.0/>).

Peer-review under responsibility of the scientific committee of the 5th CIRP Global Web Conference Research and Innovation for Future Production

Keywords: Ti-6Al-4V alloy, hole-making, helical milling, drilling, fatigue

1. Introduction

Ensuring the reliability of aircraft is a primary concern for aircraft designers and manufacturers. Civil aircrafts, carrying many passengers, constantly operate under various fatigue/shock conditions and thousands of fastener holes where fuselage skin panels are attached together are prone to fatigue. As these fastener holes produce regions of concentrated stress where fatigue cracks can initiate and propagate, they play an important role in the fatigue life of aircraft structures and are relevant to ensuring both good performance and reliability of aircraft.

Aircraft fuselage skins are commonly made of aluminum alloys, titanium alloys, and more recently carbon reinforced polymer composites [1]. Manufacturing processes can unintentionally alter material properties and often induce residual stresses which can affect fatigue life. Typically, fastener holes are made by hand using the conventional drilling process, whereby a rotating drill feeds into the fuselage skin. Recently, helical milling has been introduced which involves a milling tool travelling on a helical path into the work piece [2,

3]. In recently years, there has been a significant body of research being carried out where the two different hole making processes were compared. Sasahara et al. [4] compared the drilling and helical milling process of aluminum alloy, and found that the cutting temperature, shape error and the burr formation in the helical feed milling with minimum quantity lubrication, were all reduced when compared with the drilling process. Iyer et al. [5] compared cutting forces and hole quality in AISI D2 tool steel machined by traditional drilling and helical milling. Sadek et al. [6] studied the effects of the helical milling parameters on the hole quality, and the results showed that significant enhancement in the hole quality has been achieved by helical milling, due to the reduced axial force and cutting temperature, resulted from the redistribution of the load exerted by cutting edges. In general, helical milling has a number of advantages over conventional drilling such as the intermittent cutting process, smaller thrust force, smooth cutting process and higher accuracy [2, 3, 7]. Despite the numerous studies available in the literature, the fatigue response of the machined alloys resulting from the two different hole-making processes has been rarely compared in the

literature. This study aims to investigate the impacts of the conventional drilling process and helical milling on the fatigue response of Ti-6Al-4V (grade 5 titanium alloy) - one of the most commonly used alloys in the aerospace industry. Other material properties including the machined surface roughness and changes in microstructure have also been studied in detail.

2. Experimental

The ASTM grade 5 Ti-6Al-4V sheet had a thickness of 2.54 mm and was kindly supplied by Vulcanium Metals International. The titanium sheet has been hot rolled, annealed, descaled and levelled to meet the requirements of AMS 491 1L. With titanium as the balance, the Ti-6Al-4V contains 6.3% aluminum, 4.1% vanadium, 0.3% iron and 0.2% silicon (in wt. %). The mechanical properties of the titanium alloy are shown in Table 1.

Table 1. Mechanical properties of Ti-6Al-4V

Tensile Strength (MPa)	Yield strength (MPa)	Elastic Modulus (GPa)	Elongation (%)	Hardness (HV)
1039.2	913	97.8	11.1	342.2

The helical milling cutters used in the tests were ultra-fine-grain carbide (ISO K10) kindly supplied by the School of Mechanical Engineering, Tianjin University China. The composition of the cutter matrix is WC-8%Co and the thickness of the TiAlN coating is 1-3 μm . These tools have four teeth, an overall length of 55 mm, cutting edge length of 4 mm and a cutting edge diameter of 6 mm. The helix angle is 35°, clearance angle is 15° and the rake angle is 5°. Due to the very low cutting speeds required for using HSS drill bits to drill titanium, carbide twist drills (Guhring Ltd. tool number 5517, made of grade K carbide with two teeth) were chosen so that drilling parameters could be kept similar for both materials. The carbide twist drills were also manufactured. The carbide twist drills were also manufactured by Guhring Ltd. (Guhring tool number 5517) made of grade K carbide with two teeth.

Fatigue coupons were produced on a MIKRON UCP 600 five-axis machining centre capable of a maximum spindle speed of 12,000 rpm. The helical milling feed was realized by motion compensation of machining center. The detailed helical milling kinematics is shown in Fig. 1. As shown in the figure, the borehole is generated by a milling tool which executes a helical path in the workpiece. The three motions in helical milling process are orbital rotation, spindle rotation, and axial feed. The helical milling parameters are: D_t , tool diameters (millimeters); D_h , borehole diameters (millimeters); n , spindle rotation speed (rpm); np , orbital rotation speed (rpm); and a , feed rate in axial direction per orbital rotation (millimeters per revolution).

The cutting conditions used for helical milling and drilling are shown in Table 2 and are within the limits recommended by the tool manufacturers. For machining of coupons using external flooded coolant conditions, water soluble coolant was used which contained 8-10% oil.

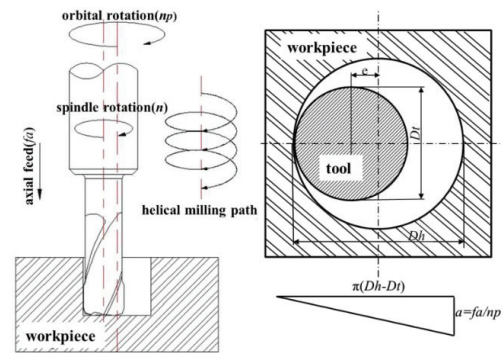

Fig.1 Schematic of the helical milling kinematics [7]

Table 2. Hole making conditions

Parameters	Drilling	Helical milling
Cutting speed	66 m/min	66 m/min
Spindle speed	2,626 rpm	3,500 rpm
Tangential feed	N/A	0.04 mm/rev
Axial feed	0.2 mm/ rev	0.2 mm/rev
Cooling condition	Dry/lubricated	Dry/lubricated

The fatigue coupons (3 of) were tested on an Instron 1343 Servohydraulic Fatigue Testing Machine (Fig. 2) and conditions is outlined in Table 3. All fatigue tests were done in compliance with ASTM E466-07.

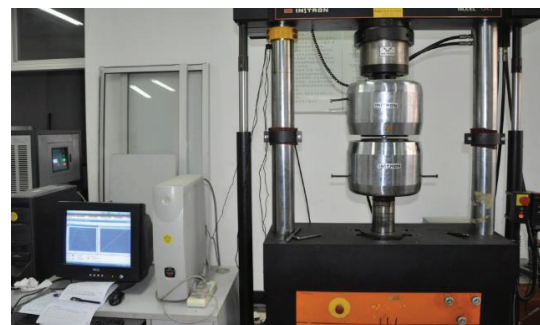

Fig.2 Instron 1343 Servohydraulic Fatigue Testing Machine

Table 3. Fatigue test parameters

Material	R	F (Hz)	F_{max} (KN)	F_{min} (KN)	F_a (KN)	σ_{max} (MPa)	σ_{min} (MPa)
Ti-6Al-4V	0.1	5	10.8	1.1	4.85	277.5	27.8

In order to enable microstructural analysis around the machined holes, an additional coupon was wire-cut through the centre of the hole using electrical discharge machining (EDM) and the surface is polished and etched for further microstructural analysis using a FEI Quanta FEG 250 Scanning Electron Microscope (SEM). Surface roughness values of the machined holes were measured using a TESA RUGOSURF 10G Portable Roughness Gauge according to ISO 4287 with a

cut-off length of 0.8 mm. Measurements were taken at three positions spaced at 90 degree intervals to obtain the average surface roughness. The main surface roughness parameter used in this study was an arithmetic mean average surface roughness, Ra.

3. Results and Discussions

A comparison of the cycles to failure for different machining conditions is shown in Fig. 3. Despite the quite large standard deviation (due to the fact that there were only three samples tested for each condition), the fatigue life of drilled titanium alloy specimens is clearly reduced under both dry and lubricated conditions. The lubricated drilled titanium alloy samples had an average fatigue life of just 7,802 cycles – almost 97% less than the average fatigue life of lubricated helical milled titanium alloy (15,337 cycles). The dry drilled titanium alloy samples show similar results with the an even shorter fatigue life of just 6,797 cycles – 119% lower than that of dry helical milled samples.

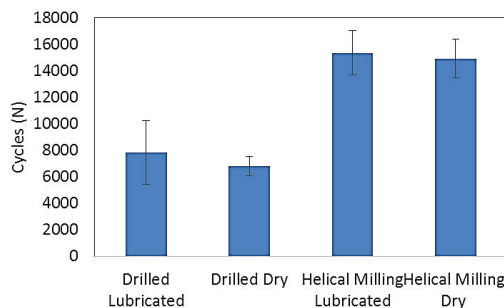

Fig.3 A comparison of the cycles to failure for different hole making processes

The reduction in fatigue life for drilled samples and samples under dry conditions is most likely due to the surface integrity of the machined part. Surface roughness (R_a) of holes produced by different processes has been shown in Fig.4. It can be seen that helical milling generally lead to lower surface roughness compared to drilled surface. The presence of lubrication further reduces the surface roughness for both machining processes. The surface roughness produced by drilling (dry) is the highest ($0.875 \mu\text{m}$) amongst all measurements. It is known that the fatigue test can serve as a first order approximation for fatigue crack initiation [8] and the greater surface roughness of samples machined by drilling without cutting fluid was most likely the greatest contributor to the reduction in fatigue life. The rougher surfaces and presence of notches, particularly in drilled specimens, meant greater stress concentrations which provide fatigue crack initiation sites, and a subsequent reduction in fatigue life [9].

Data for individual coupon shows that the initial drilled samples had longer fatigue lives than the second and third drilled samples, which suggests that tool wear of the drill bit may have caused a reduction in hole quality which is known to reduce fatigue life [10-12]. For helical milling, the first

machined samples showed fatigue lives 1,303 and 2,057 cycles shorter than the second machined sample for lubricated and dry conditions respectively. This could be because of the “warming up” of the tool material because when the tool is first used, there can be micron-level sharp edges/peaks at its surface that can be trimmed out to create a smoother contact surface with the workpiece [13]. Che-Haron et al. [14, 15] found for titanium alloy, the machined surface roughness values were higher when a tool was fresh when machining. Ulutan et al. [13] have also suggested that as the tool starts from its fresh state, higher tensile residual stresses can be observed which can be detrimental to fatigue performance.

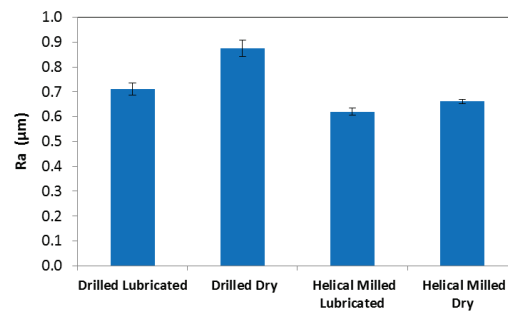

Fig. 4 Average surface roughness measurements of hole surfaces

Figure 5 shows the SEM images of the sub-surface microstructures of holes (cross-sectional view) produced under all machining conditions. Drilled samples (lubricated and dry, Fig.5 (a) and (b)) showed severe sub-surface plastic deformation with the deformed region being approximately $30 \mu\text{m}$ thick. Minimal microstructural deformation was observed for helical milling processes in titanium alloy (Fig. 5(c) and (d)) although a cavity was found at the machined surface in dry helical milling, see Fig. 5d inset, which could act as a stress concentration site for crack initiation.

Higher temperatures generated under drilled conditions combined with the low thermal conductivity of Ti-6Al-4V meant thermal softening increased the contact area between the tool and workpiece thus causing an increase in depth of the deformed layer [16]. Elongated grains are also visible in Figure Fig. 5 (b) after drilling, similar to the findings of Hughes et al. [14, 17].

Conclusions

In this study we compared the effects of two hole making processes, namely, conventional drilling and helical milling on the machined surface microstructure and fatigue behavior of Ti-6Al-4V aircraft alloy. Results show that the helical milling results in longer fatigue life as compared to conventional drilling, which can be correlated to the lower machined surface roughness and less severe plastic deformation produced by the helical milling process. The presence of lubricant helps to reduce surface roughness and improve fatigue life. The presented work shows that helical milling process can be

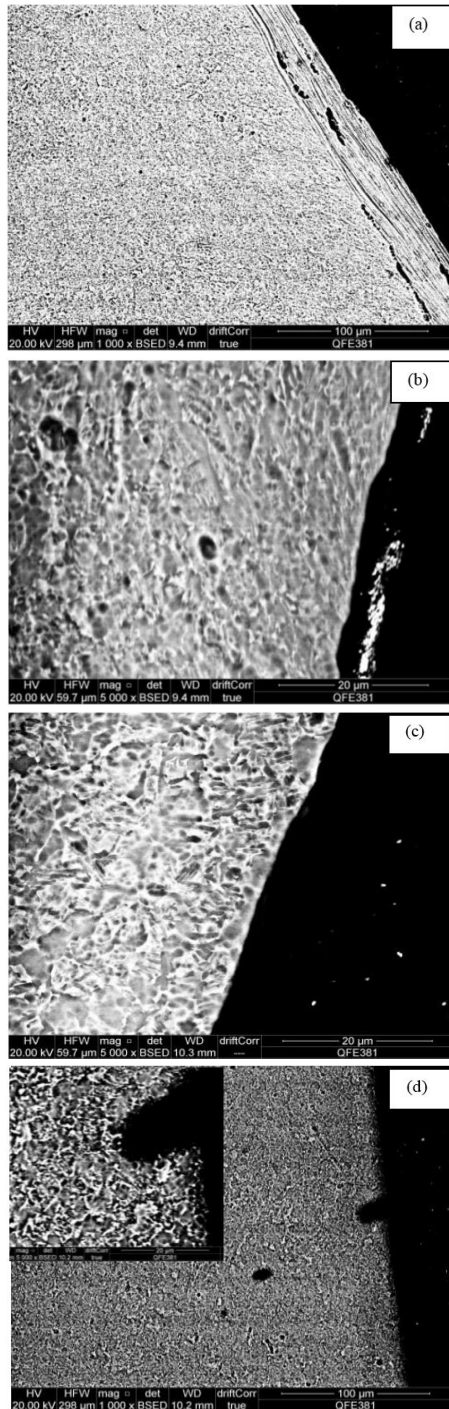

Fig. 5 Sub-surface microstructures of Ti-6Al-4V after hole-making processes (a) drilled lubricated (b) drilled dry (c) helical milled lubricated, (d) helical milled dry.

considered as a promising manufacturing technology in the future aircraft assembly process.

Acknowledgement

Funding support from NSF China (No. 51420105007) is acknowledged.

References

1. Federal Aviation Administration. *Aircraft Materials, Processes & Hardware. Aviation Maintenance Technician Handbook*. 2008: U.S. Department of Transportation: Federal Aviation Administration.
2. Zhao Q, Qin X, Ji C, Li Y, Sun D, Jin Y. *Tool life and hole surface integrity studies for hole-making of Ti6Al4V alloy*. Int J Adv Manuf Technol 2015. **79**:1017-1026.
3. Ji C, Li Y, Qin X, Zhao Q, Sun D, Jin Y. *3D FEM simulation of helical milling hole process for titanium alloy Ti-6Al-4V*. Int J Adv Manuf Technol 2015. **81**(9): 1733-1742.
4. Sasahara H, Kawasaki M, Tsutsumi M. *Helical Feed Milling with MQL for Boring of Aluminum Alloy*. J Adv Mech Des Sys & Manuf 2008. **2**(6): 1030-1040.
5. Iyer R, Koshy P, Ng E. *Helical milling: an enabling technology for hard machining precision holes in AISI D2 tool steel*. Int J Mach Tools Manuf, 2007. **47**: 205-210.
6. Sadek A, Meshreki M. and Attia M.H. *Characterization and optimization of orbital drilling of woven carbon fiber reinforced epoxy laminates*. CIRP Annals - Manuf Tech, 2012. **6**: 123-126.
7. Li H, He G, Qin X, Wang G, Lu C, Gui L. *Tool wear and hole quality investigation in dry helical milling of Ti-6Al-4V allo*. Int J Adv Manuf Technol 2014. **71**: 1511-1523.
8. Leyens C, Peter M. *Titanium and titanium alloys :fundamentals and applications*. 2003: Weinheim: Wiley-VCH.
9. Pei X, Chen W, Ren B, Han Y. *Effect of drilling processes on surface integrity of 7075-aluminum alloy holes*. J Beijing Univ Aeronautics & Astronautics, 2002. **28**: 319-322.
10. Liu J, XH, Zhai HB, Yue ZF. *Effect of detail design on fatigue performance of fastener hole*. Mater Des, 2010. **31**: 976-980.
11. Ralph WC, Johnson WS, Makeev A, Newman Jr. JC. *Fatigue performance of production-quality aircraft fastener holes*. Int J Fatigue, 2007. **29**: 1319-1327.
12. Liu J, Shao XJ, Liu YJ, Liu YS, Yue ZF. *The effect of holes quality on fatigue life of open hole*. Mat Sci & Eng: A 2007. **467**: 8-14.
13. Ulutan D, Ozel T. *Machining induced surface integrity in titanium and nickel alloys: A review*. Int J Mach Tools Manuf 2011. **51**: 250-280.
14. Che-Haron CH, Jawaid A. *The effect of machining on surface integrity of titanium alloy Ti-6% Al-4% V*. J Mater Process Technol, 2005. **166**:188-192.
15. Che-Haron CH. *Tool life and surface integrity in turning titanium alloy*. J Mater Process Technol 2001. **118**: 231-237.
16. Nouari M, Makich H. *On the Physics of Machining Titanium Alloys: Interactions between Cutting Parameters, Microstructure and Tool Wear*. Metals 2014. **4**: 335-358.
17. Hughes JI, Sharman A, Ridgway K. *The effect of tool edge preparation on tool life and workpiece surface integrity*. Proc Inst Mech Eng Pt B: J Eng Manuf 2004. **218**: 1113-1123.