



The performance of a cathodic protection system in reinforced concrete structure: Monitoring and Service Life Modelling

Ward, C., Nanukuttan, S., & McRobert, J. (2014). The performance of a cathodic protection system in reinforced concrete structure: Monitoring and Service Life Modelling. Paper presented at Civil Engineering Research in Ireland Conference (CERAI), Belfast, United Kingdom. DOI: 10.13140/2.1.4462.4962

Document Version:
Peer reviewed version

Queen's University Belfast - Research Portal:
[Link to publication record in Queen's University Belfast Research Portal](#)

Publisher rights
Copyright 2014 the authors.
For figure 1 request permission from Concrete Preservation Technologies.

General rights
Copyright for the publications made accessible via the Queen's University Belfast Research Portal is retained by the author(s) and / or other copyright owners and it is a condition of accessing these publications that users recognise and abide by the legal requirements associated with these rights.

Take down policy
The Research Portal is Queen's institutional repository that provides access to Queen's research output. Every effort has been made to ensure that content in the Research Portal does not infringe any person's rights, or applicable UK laws. If you discover content in the Research Portal that you believe breaches copyright or violates any law, please contact openaccess@qub.ac.uk.

The Performance of a Cathodic Protection System in Reinforced Concrete Structure: Monitoring and Service Life Modelling

Cillian Ward¹, Sreejith Nanukuttan², John McRobert³

¹4th Year Civil Engineering, School of Planning Architecture and Civil Engineering, Queens University Belfast

²School of Planning Architecture and Civil Engineering, Queens University Belfast, Northern Ireland, BT9 5AG

³Roads Service Highways Structures Unit, County Hall, 182 Galgorm Road, Ballymena, Northern Ireland, BT42 1QG

Email: cward24@qub.ac.uk, s.nanukuttan@qub.ac.uk, john.mcrobert@drdni.gov.uk

ABSTRACT: The use of cathodic protection in reinforced concrete is becoming increasingly common with such systems being installed on a number of structures throughout the United Kingdom and Ireland. However the prescribed design lives (or service life) of each cathodic protection system vary widely. The aim of this project was to assess the effectiveness of a sacrificial anode cathodic protection system and to predict its design life through a series of laboratory based experiments. The experimental plan involved casting a number of slabs which represented a common road bridge structure. The corrosion of the steel within the experimental slabs was then accelerated prior to installation of a cathodic protection system. During the experiment corrosion potential of the steel reinforcement was monitored using half-cell measurement. Additionally the current flow between the cathodic protection system and the steel reinforcement was recorded to assess the degree of protection. A combination of theoretical calculations and experimental results were then collated to determine the design life of this cathodic protection system. It can be concluded that this sacrificial anode based cathodic protection system was effective in halting the corrosion of steel reinforcement in the concrete slabs studied. Both the corrosion current and half-cell potentials indicated a change in passivity for the steel reinforcement once sacrificial anodes were introduced. The corrosion current was observed to be sensitive to the changes to the exposure environment. Based on the experimental variables studied the design life of this sacrificial anode can be taken as 26 to 30 years.

KEY WORDS: CONCRETE DURABILITY; CATHODIC PROTECTION; HYBRID ANODES, SACRIFICIAL ANODES; CONCRETE REPAIR, HIGHWAY STRUCTURES, MONITORING, DESIGN LIFE.

1 INTRODUCTION

Reinforced concrete is one of the most versatile and high performance construction materials and has been in use for hundreds of years. There are vast arrays of civil engineering structures that incorporate reinforced concrete such as bridges, water retaining structures, multi storey buildings and maritime structures. Many of which have been in service for decades, leaving the civil engineers of today with an ageing infrastructure that must be maintained.

In many cases reinforced concrete structures have met and surpassed their design lives with no significant signs of deterioration. However it has been observed that the onset of corrosion of steel reinforcement has led to deterioration in many structures much earlier than expected. As discussed by Burke [1] deterioration of reinforced concrete due to corrosion of reinforcing steel is more prevalent in saline environments, this means that marine and highway structures such as jetties and bridges are particularly at risk of premature deterioration. Based on the factors that have been found to affect corrosion all new build structures are designed with corrosion mitigation in mind, so that onset of corrosion is delayed as much as possible. Nevertheless, repair is essential for those structures that are actively corroding. The most commonly used method of corrosion control is cathodic protection which can be retrofitted to degrading structures relatively un-invasively. A large variable of cathodic protection is its effective design life (or service life after installation) which can have major cost implications; the prediction of this design life formed the key

objective of this project. As such the effective design life of cathodic protection is an area of interest to all utilities involved in the maintenance of reinforced concrete structures. One such agency is the "Road Service of Northern Ireland" which is responsible for the maintenance of hundreds of reinforced concrete road bridges and other reinforced concrete structures. For the purposes of this project an idealised scenario was created with input from Road Service to examine the effectiveness of a specified cathodic protection system and predict the design life of such a system. The Road Service provided details of "CP-Tech Duo guard 500 Hybrid Sacrificial Anode System," which was of interest to them for the protection of concrete road bridges.

1.1 Outline of the experimental plan and project objectives

A number of concrete slabs were created with similar mix design as that of an ageing road bridge. Corrosion in the steel reinforcement was accelerated using anode/cathode system and an external current source. A "CP Tech duo guard 500 sacrificial anode system [2]" was then installed as per the supplier's recommendations and current flowing to the anode and the change of half-cell values of the steel, etc were assessed to study the performance of the sacrificial system. The main objectives of the project were:

1. To determine whether the corrosion of steel reinforcement can be halted by the installation of sacrificial anodes.

- Predict the design life of a sacrificial anode based on the mass loss of the anode over the period during which it is operational.
- Compare the effect of placement/location and quantities of sacrificial anodes on the corrosion mitigation behaviour.

2 CATHODIC PROTECTION SYSTEM

In cathodic protection, a weak metal (known as a sacrificial anode) is electrically connected to an existing useful metal such as structural steel or rebar. [1] The weak metal becomes the anode of the system and corrodes readily, while the existing structural metal becomes the cathode and remains protected. Cathodic protection is dependent on the flow of current between anode and cathode and consequently there will be an ionic flow from anodic region to cathodic region. The current flow is maintained through an electrical connection, whereas the ionic flow relies on the presence of a conductive media such as concrete pore water. The most common use of cathodic protection in reinforced concrete is as a retrofitted system used to prevent further corrosion of steel reinforcement. This project will focus on retrofitted system that is installed on steel reinforcement which has already begun to corrode with the aim of controlling further corrosion.

2.1 Duoguard 500 Hybrid Anode

The anode used in this study was Duoguard 500 hybrid anode which is designed to act as impressed current anode in the short term and galvanic anode in the long term with the aim of offering the advantages of both types of cathodic protection. During the impressed current phase an external direct current power supply is connected between the Duoguard anodes and steel reinforcement in order to control the polarity of steel reinforcement (to make it negative). The Duoguard is used here as the sacrificial metal that offers free electrons to suppress the corrosion reaction in reinforcement steel. This stage lasts for one week for these particular anodes. After the impressed current phase the Duoguard anodes are electrically connected to the steel without an external power supply and therefore act in a galvanic manner and provide a long term protection. The assumptions here are: (1) the conductivity of concrete is sufficient to allow ionic mobility between cathode to anode, (2) sacrificial anodes goes into solution to release electrons to protect reinforcing steel and (3) deposition of reaction products on the surface of sacrificial anode does not affect its long term performance.

The anodes used in this project were installed by drilling into a concrete surface; the anode is inserted and grouted in place. An advantage of probe style anodes is that the pathway between the galvanic anode and the cathode reinforcement is quite short resulting in an increased rate of current flow which in theory provides better protection while it also causes accelerated consumption of the galvanic anode. A general arrangement drawing for a probe style galvanic anode is shown in Figure 1.

3 EXPERIMENTAL REPORT

3.1 Phase 1: Production of slabs representative of an ageing highway bridge

The first stage of experimental programme was the design of the steel reinforcement to initiate rapid corrosion. 10mm and 40mm rebar were used to create a large cross sectional area ratio 1:16 to ensure that the 10mm steel positioned closed to the surface would readily become the anode during the forced corrosion stage while the 40mm steel acts as the cathode. Detail of the layout is given in Figure 2.

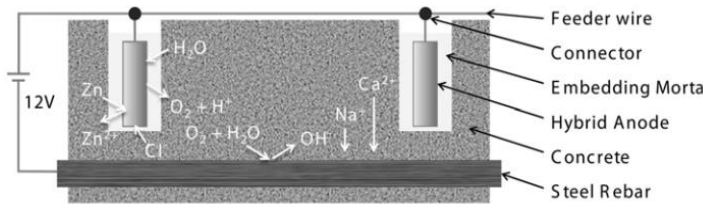
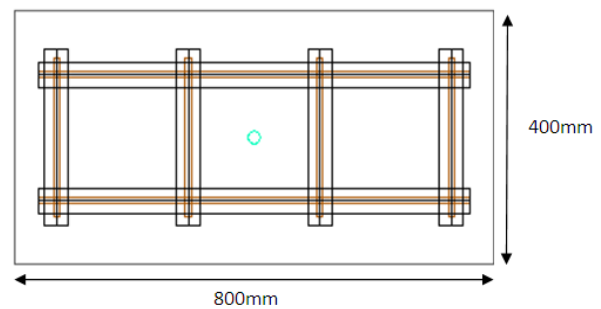
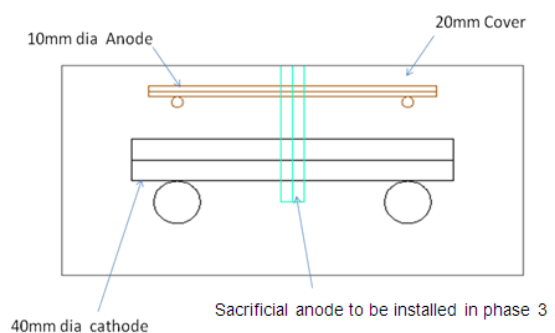

Figure 1. Diagram of probe impressed current arrangement and reactions that occur (Concrete Preservation Technologies, 2012)



2(a) Plan view of slab 1 showing position of anodes/cathodes
Light green circle shows the location at which the sacrificial anode was installed in Phase 3.



2(b) Cross-sectional view of the slab 1

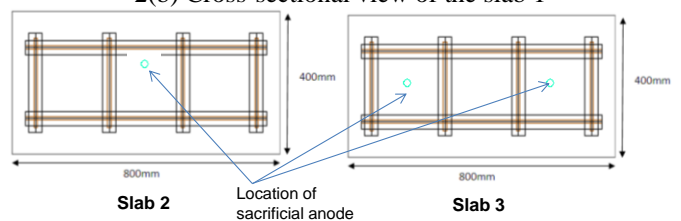

2(c) Plan view of slabs 2 and 3 showing the location of sacrificial anodes.

Figure 2. Layout of a slab showing anodes and cathodes with provision for the installation of sacrificial anode in the middle.

Horizontal spacing's of 240mm centre to centre were chosen for both the 10mm and 40mm rebar, the perpendicular stirrups were also to be spaced at 240mm centres which are reasonably comparable dimensions with bridge deck design, the rebar had a length of 720mm so that the slabs would have a rectangular shape.

The vertical spacing between the top (anode) and bottom (cathode) steel was reduced to 95mm in order to ensure that the rate of corrosion of steel reinforcement could be accelerated. A minimum cover of 40mm was provided to all rebar except for the anode which had only 20mm cover to the top of the concrete surface.

Three slabs of identical reinforcement layout were created. The only change between the slabs is the location and number of sacrificial anodes installed during the corrosion protection stage. Slab 2 had the sacrificial anode installed closer to the steel reinforcement and slab three had two sacrificial anodes installed refer to Figure 2c for further details.

A concrete mix design was carried out in accordance with D.O.E Mix design. The final mix details are shown in Table 1.

Table 1 Concrete mix details

Material	Mass of materials for 1m ³ concrete		
	kg/m ³	Ratio by mass	Equivalent Ratio
Portland Cement	305	0.127	1.000
Dry Sand	650	0.270	2.131
Basalt Aggregate	1290	0.537	4.229
Water	155	0.064	0.508
Calcium Chloride	0.5	0.001	0.002
Total	2400.5	1	7.870

The cement content of the mix was kept deliberately low (305kg/m³) as this would have been a common cement content in historical mixes. Also the calcium chloride content was 1% by weight of cement, this would have been a typical quantity of admixture in the past and also aids the acceleration of corrosion. For monitoring and impressed current purposes a number of electrical wires were to be connected to the rebar; the method for installation of these is as follows:

1. A 6mm diameter 8mm deep hole was drilled into the 40mm steel at its midpoint. On the 10mm diameter rebar a 2mm diameter hole was drilled.
2. Titanium wire was cut into lengths and separate wires were inserted individually into the drilled holes.
3. On the 40mm diameter rebar a 5mm diameter pop rivet was inserted in order to secure the wire to the rebar. On the 10mm rebar the titanium wire was wrapped around the rebar and secured using insulating tape.

All electrical wire connections to the rebar were insulated by either coating with silicone (40mm rebar) or wrapping with insulating tape (10mm rebar) to prevent induction of corrosion at the electrical connection sites. The concrete for the slabs was mixed and poured on the 11/12/2012. The concrete

surface was finished by hand float. After 5 days the slabs were removed from their formworks and moved outside to begin the accelerated corrosion phase of the project.

3.2 Phase 2: Acceleration of corrosion of steel in slabs

The accelerated corrosion schedule is shown in Figure 3.

Programme of Accelerated Corrosion	
Date	Activity
20/12/2012	Slabs Moved Outside (No External Voltage)
20/12/2012 – 03/01/2013 (14 days)	Passive Corrosion Phase
03/12/2012 – 07/01/2013 (4 Days)	Impressed Current Corrosion Phase (7V External Voltage)
07/12/2012 – 17/01/2013 (11 Days)	Impressed Current Corrosion Phase (12V External Voltage)
17/01/2013 – 14/02/2013	Passive Corrosion Phase 2 (No External Voltage)

Figure 3. Schedule of activities to initiate corrosion in test slabs

After 11 days it was found that significant surface cracking had occurred along the lines of the rebar, these cracks had been developing throughout the impressed current corrosion phase. Rust staining was also observed weeping from the surface cracks on the slabs. A picture of the corroded slabs is shown in Figure 4. After it became clear that extensive corrosion was occurring, the power supply was switched off and the slabs were left ready for the installation of a cathodic protection system. During the accelerated corrosion phase half cell readings were taken at regular intervals to confirm whether corrosion was occurring.

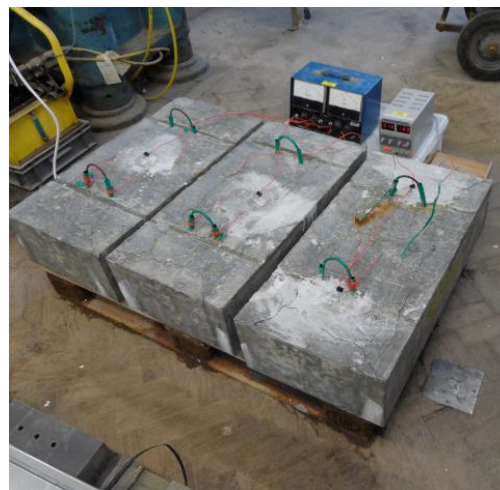

Figure 4. Slabs undergoing accelerated corrosion

3.3 Phase 3: Installation of cathodic protection system and impressed current

The sacrificial anodes were installed in accordance with the manufacturer's instructions. The 12v power supply was connected one day after the installation of anodes and remained connected for seven days. The 12v supply should have induced enough current flow to effectively halt the corrosion of the 10mm anode steel causing it to become a

protected cathode steel which is protected by the corrosion of the sacrificial anode. At the end of impressed current phase the external voltage was removed and sacrificial anodes were left to act passively within the slabs. Current flow between the sacrificial anode and steel was monitored during this phase to study the activities. This is explained in Phase 4.

3.4 Phase 4: Galvanic cathodic protection and monitoring phase

Phase 4 of the project involved monitoring the sacrificial anodes while they act in their passive galvanic capacity (no external voltage was applied during this phase).

An automated data recording system was set up to record the voltage difference between the sacrificial anode and 10mm steel reinforcement. In theory if the sacrificial anode is corroding to provide protection to the reinforcement steel there will be a current flow between the two. Therefore by recording the voltage the effectiveness of the cathodic protection can be assessed.

Current measurements were taken at 15 minute intervals between the dates of 22/02/2013 and the 19/04/2013. After a number of readings had been recorded in the lab it was decided that the slabs should be moved outside to test the effects of the increased moisture present in an external environment. The slabs were moved outside on 26/03/2013 and remained outside until the end of the monitoring phase. The sacrificial anodes were removed from the slabs by drilling a 50mm core hole at each anode location and the anodes were weighed to quantify the mass loss.

3.5 Phase 5: Data Analysis

Data analysis involved collating the recovered data from the automated recorder and the half-cell measurements to produce a set of test results. This is explained further in the next section.

4 RESULTS AND ANALYSIS

4.1 Half Cell Monitoring

Half cell monitoring was carried out over the duration of the project to determine the degree of reinforcement corrosion occurring within the slabs at a given moment.

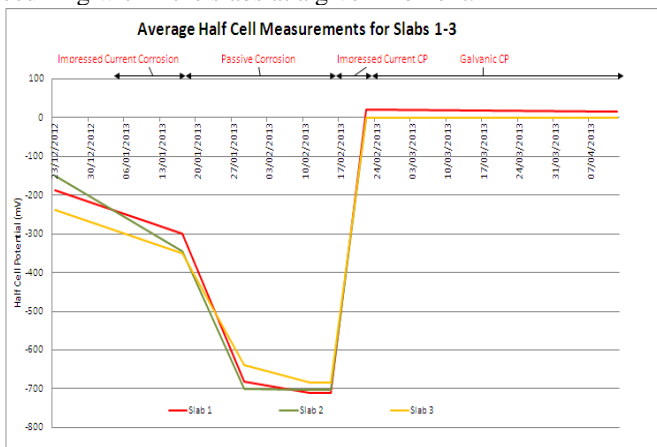

Figure 5 Half-cell measurements from each slab during

different phases of corrosion

Figure 5 shows an overview of the average half-cell results obtained during the key phases during this project. The three slabs performed in a similar fashion; all three corrode at a rapid rate during the accelerated corrosion phase (phase 2) and experience a sharp rise in half cell potential during the impressed current cathodic protection phase.

Figure 5 also shows that during the application of an external current the average half cell potentials declined to between -300mv and -400mv which suggests that there was a high risk of corrosion of the reinforcing steel. The graph also shows that the largest drop in average half-cell potential occurred during the passive corrosion period after the impressed current was applied. During this period the potential value declined to between -680 and -700 indicating a severe degree of corrosion.

The half cell results compliment the laboratory observations to confirm the presence of extensive corrosion on the reinforcing steel prior to the installation of the cathodic protection system. It can also be seen that the average half cell potentials increased exponentially after the commencement of the impressed current cathodic protection phase from between -650 and -700 to between 0 and 20. This massive increase in half cell potential suggests that the corrosion of the 10mm steel reinforcement had been halted. A number of subsequent half cell tests taken during phase 4 of the project showed that there had been no significant further drop in half cell potential. These results suggest that the corrosion of the steel reinforcement was indeed halted by the cathodic protection system and that the system continued to protect the reinforcement while acting in its galvanic capacity.

However it was also important to assess the pattern of the half-cell results to determine whether any areas in the slabs were experiencing much lower or higher half cell potentials than the others. Large variations in potential from one reading to the next may indicate that only localised corrosion is occurring as opposed to the desired wide spread corrosion of the 10mm rebar. It was possible to assess the pattern of corrosion within the slabs by generating a number of contour plots of the half-cell results. From the contour plots it was found that steel positioned closer to the sacrificial anodes had higher half-cell potentials which may be further evidence that the corrosion of steel reinforcement was halted and subsequently protected by the cathodic protection. This data is not included in this paper due to page limit restrictions.

4.2 Monitoring corrosion current

The sacrificial anode and reinforcement steel was connected electrically and the current flow in this circuit was measured by noting down the voltage values (Figure 6) across a known electrical resistance. This is a common procedure adopted in studying the corrosion of steel in laboratory based concrete specimens. The voltage difference relates directly through ohms law to the current flow between the sacrificial anode and reinforcement steel and as such should indicate the degree of protection offered to the steel by the cathodic protection system. If the readings remain above zero an ionic current will

be present and as a result the steel reinforcement can be considered to be protected. However if there is no voltage difference or a negative reading there will be no ionic flow between the sacrificial anode and steel reinforcement, this would mean that the steel could once again begin to corrode.

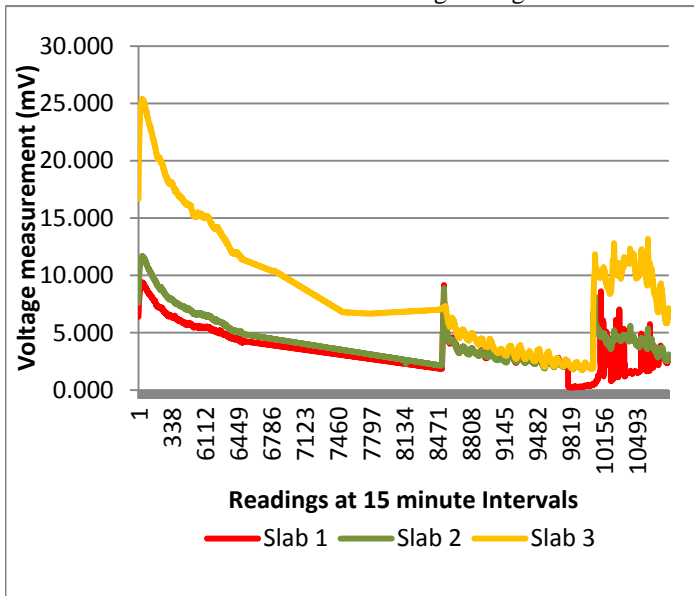

Figure 6. Potential difference between sacrificial anode and steel reinforcement measured on all 3 slabs.

From Figure 6, it can be seen that the voltage peaks quite early near the beginning of monitoring with slabs 1, 2 and 3 peaking at 26mV, 12mV and 9mV respectively. An explanation for this is that voltage monitoring began immediately after the end of the impressed current cathodic protection phase, the externally applied current from this phase will have generated a high current flow between the sacrificial anode and reinforcing steel. This current may not have dissipated immediately, resulting in slightly higher voltage readings during the early stages of monitoring.

The trend-line of the voltage readings in each of the three slabs shows that as time progresses the level of activity decreases significantly. This indicates either that the level of residual corrosion activity is low or that the effectiveness of the system reduces over time. However it can be seen that once the slabs were moved outside (time = 9819) the voltage readings in all three immediately increased this is most likely due to the ingress moisture which increases ionic flow. This observation also suggests that the reason for the declining effectiveness may have been due to the low moisture environment of the laboratory.

During the period that the slabs are outside the voltage readings appear to fluctuate frequently, it can also be seen that at one point the voltage in slab 1 drops very close to 0. The primary reason for these variable results is weather; during the period where the slabs were stored outside there was an unseasonal drop in temperature and heavy snow for 6-7 days. During the period of snow any water present both inside and outside the slabs is likely to have frozen to form ice, ice is a less useful electrolyte than free water and as a result the current flow in the slabs is likely to have been inhibited. The low temperatures that were experienced by the slabs are likely to have reduced the overall ionic flow between the sacrificial

anodes and the steel. The small fluctuations that are visible are due to the daily changes between night and day where a freeze-thaw cycle occurs. These conditions were unexpected at the time of year when the experiment took place however they are none the less useful in assessing the performance of the cathodic protection system under varying weather conditions.

4.3 Design Life prediction using mass loss and voltage monitoring

In order to assess the design life of each of the sacrificial anodes it was necessary to calculate the total mass of material lost during their operational lives. There are two ways to do this, theoretically using Faraday's law or experimentally by weighing the anodes and recording the variation in weight.

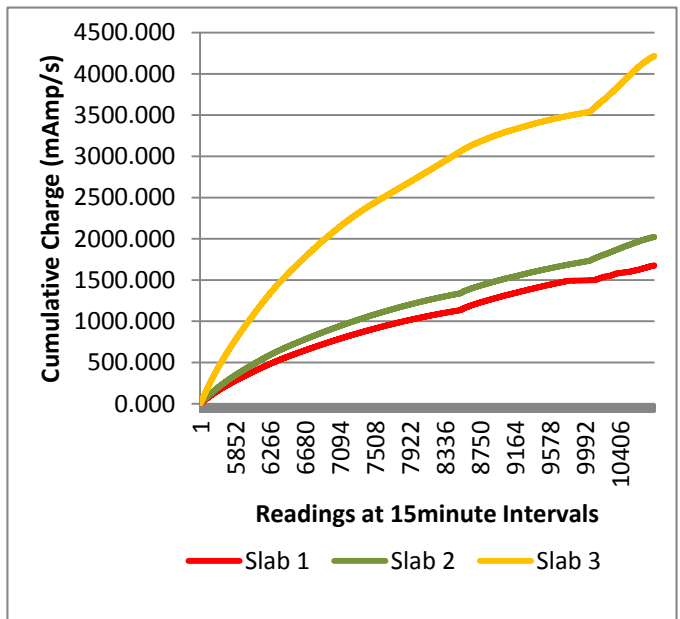

Figure 7 Cumulative charge flow for the 3 slabs quantified from the voltage measurements.

The theoretical process uses Faradays law which relates the charge passed to the mass lost. The calculated values of cumulative charge for slabs 1, 2 and three are 1677.212, 2023.722 and 4222.068 respectively. This computed by converting the voltage measurements to current and integrating this graph to find the area under the current-time graph to determine charge passed.

An example of the calculation for slab 1 is shown below:

Faradays Law states that:

Mass Loss (M)

$$= \frac{\text{Charge Passed (Q)}}{\text{Faradays Constant } \left(\frac{\text{Q}}{\text{mol}}\right)} \times \frac{\text{Molecular Mass of Material } \left(\frac{\text{g}}{\text{mol}}\right)}{\text{Valency of Material}}$$

Faradays Constant = 96500 Q/mol

Molecular Mass of Zinc (anode material) = 65.382 g/mol

Valency of Zinc = 2

For Slab 1 Charge passed = 1677.212 Coulombs

Substituting values in the above equation gives a theoretical mass loss value of 0.568g for the sacrificial anode installed in slab 1.

Table 2 presents the actual mass loss calculated from experiments. It can be seen that for the anodes recovered from slabs 1 and 2 the mass losses were 0.7 and 0.9 grams respectively. Unfortunately both of the anodes from slab 3 were damaged during removal resulting in additional mass loss making their weights useless for the purpose of prediction of design life as a consequence they have been omitted from Table 2.

Table 2 Actual mass loss and experimental rate of consumption of anodes/day

Sacrificial anode reference	Weight Prior to installation (g)	Mass loss (g)	Rate of consumption (per day)	Predicted design life
Slab 1: Anode 1	187.8	0.7	0.0125	26.783
Slab 2: Anode 2	188.1	0.9	0.0161	20.831

For example, design life of Slab 1 Anode 1 is:

$$\text{Design life} = 65\% \text{ of } \{(187.8\text{g} \div 0.0125 \text{ g/day})/365\} = 26.783$$

65% refers to the efficiency of anodes or maximum consumption that can occur.

As given in Table 3, the theoretical mass loss (based on charge passed) for slab 1 and slab 2 were found to be 0.568 and 0.686g, respectively. Both values are comparable to the actual mass loss determined from experiments. The design life in Table 2 is calculated by assuming a constant rate of consumption of anodes for the entire service life. This shows a design life of 20-26 years. Such linear decay is not realistic for most structures. After the initial increase in consumption of charge, the charge required to maintain the passivity of reinforcement steel is likely to be low. If the latter phase is considered separately a more accurate service life can be estimated. This is referred to hereafter as variable decay approximation. To generate a more accurate prediction the cumulative charge measurements was split into two groups; the mass loss during impressed current phase (1 week) and the galvanic phase when voltage readings appear to plateau. This is termed as variable approximation and in summary this was made by treating the mass loss during the early stages of the experiment as an initial consumption and using the charge recordings during the less variable final 10 days of the experiment to generate a long term picture.

Table 3 Design life estimated assuming a variable decay of sacrificial anodes over time

Variable Approximation of Design Life of Anodes				
Slab Reference	Theoretical Mass Loss (g)	Mass loss per Anode (g)	Mass loss per day (g)	Variable approximation of Design Life (Years)
Slab 1	0.063	0.063	0.006	52.861
Slab 2	0.113	0.113	0.011	29.524
Slab 3	0.245	0.122	0.012	27.249

There are significant variations in the two sets of design life predictions. The weight change prediction assumes a linear decay of anode per design life and hence it is not comparable to the design life predicted using variable decay method.

Other notable observations are:

The design life's for the anodes in slabs 1 and 2 are very different although both slabs have the same steel arrangement and 1 sacrificial anode each. The location of installation of anode is the only variable between the slabs. The design life in Table 1 and Table 3 is estimated based on data observed for 56 days and the duration may not be sufficiently long to study the effect of this variable.

Slab 3 contained two sacrificial anodes as opposed to 1 anode each installed in slab 1 and 2. The increased anode configuration may have resulted in a more rapid protection offered for the reinforcement steel. This may justify the higher charge flow observed in Figure 7 for slab 3. A design life estimated based on the higher charge flow will always give a conservative estimate. In order to accurately estimate the design life of anodes in this configuration a long term study is required.

The experimental programme had limitations in terms of number of replicate specimens studied. Therefore, a long term study is recommended to validate the procedure/protocol outlined here for estimating the design life.

6.0 Concluding remarks

The results indicate that the CP-Tech sacrificial anodes have effectively controlled corrosion of the steel. The current (voltage) flow recorded shows the level of activity of steel reinforcement and also gives an opportunity to estimate the design life. Half-cell values confirm the findings deduced from the current measurements.

The current measurement indicates that the position of sacrificial anode does have a positive effect on the current flow during initial stages of CP system. This suggests a faster mitigation of corrosion or higher degree of protection of steel. However, the long term effect of the position of installation needs to be studied further. A similar positive effect was observed for slab 3 where 2 sacrificial anodes were installed. Half-cell or corrosion current can be used to monitor the effectiveness of corrosion protection systems in real structures. The data seems to be sensitive to external weather events and moisture condition of the structure.

A simpler method for determining the design life of CP system was put forward using Faraday's law and current/voltage measurements. This needs to be validated based on long term data.

The following key variables should be given consideration for further work: (1) conductivity of the concrete, (2) changes in resistivity value between anode and cathode interface, (3) temperature effect and (4) role of corrosion residue that forms on the surface of sacrificial anodes on the working of anodes.

REFERENCES

- [1] Burke, N. S., 1994. Corrosion Activity of steel Reinforced Concrete Structures. 1 ed. Baltimore: ASTM Publishing.
- [2] Concrete Preservation Technologies, 2012. *DuoGuard Hybrid Anode System*. <http://cp-tech.co.uk/wp-content/uploads/2012/06/DuoGuard-Datasheet-R2.pdf>
- [3] Bob Cotis; University of Manchester, 2003. *Performance of Sacrificial Anodes for use in Reinforced*, Manchester: s.n.