



Price, Andrew and Oliver, Mary and Joshua, McGrane (2015) What's working memory to do with it? A case study on teenagers. *Teaching Science*, 61 (2). pp. 26-32. ISSN 1449-6313

**Access from the University of Nottingham repository:**

<http://eprints.nottingham.ac.uk/32090/1/Price%2C%20McGrane%2C%20Oliver.pdf>

**Copyright and reuse:**

The Nottingham ePrints service makes this work by researchers of the University of Nottingham available open access under the following conditions.

- Copyright and all moral rights to the version of the paper presented here belong to the individual author(s) and/or other copyright owners.
- To the extent reasonable and practicable the material made available in Nottingham ePrints has been checked for eligibility before being made available.
- Copies of full items can be used for personal research or study, educational, or not-for-profit purposes without prior permission or charge provided that the authors, title and full bibliographic details are credited, a hyperlink and/or URL is given for the original metadata page and the content is not changed in any way.
- Quotations or similar reproductions must be sufficiently acknowledged.

Please see our full end user licence at:

[http://eprints.nottingham.ac.uk/end\\_user\\_agreement.pdf](http://eprints.nottingham.ac.uk/end_user_agreement.pdf)

**A note on versions:**

The version presented here may differ from the published version or from the version of record. If you wish to cite this item you are advised to consult the publisher's version. Please see the repository url above for details on accessing the published version and note that access may require a subscription.

For more information, please contact [eprints@nottingham.ac.uk](mailto:eprints@nottingham.ac.uk)

## WHAT'S WORKING MEMORY TO DO WITH IT? A CASE STUDY ON TEENAGERS

Effective teachers recognise that as their students grow, the way in which their students learn changes. This is related to different developmental stages of the brain that occur as a child becomes an adult. This article discusses the concept of working memory and explores how working memory changes during adolescence. The research presented here used an approach to measuring working memory using electroencephalography (EEG) to examine differences in the capacity for using working memory between older and younger adolescent students at a school in Western Australia. The differences in the neurological processes related to working memory in adolescents of different ages were examined with implications for teachers in secondary schools.

### Working Memory

Working memory (WM) has become a specialised area of brain research and in the large number of published studies using fMRI and EEG have contributed to our understanding of causes of the role WM plays in for example, autism, dyslexia, and dyscalculia. Can we improve or train WM, as some suggest, or is this a fixed biological variable that will limit our capacity to learn? One definition describes WM as a cognitive system that allows for the temporary storage and manipulation of information (Baddeley, 2003). This capacity to store, attend to and process information varies between individuals. As children mature, their WM increases over time so older children can 'hold' more bits of information than younger children. These changes are related to the development and organisation of the prefrontal cortex of the brain (Luciana, Conklin, Hooper, & Yarger, 2005).

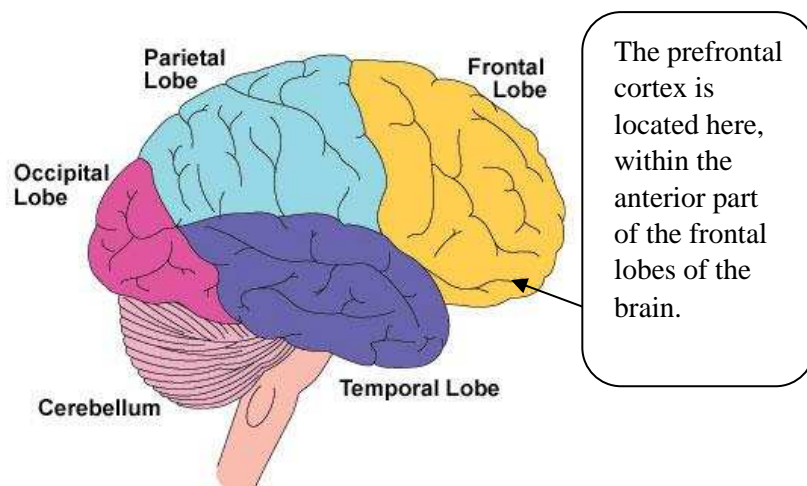

Figure 1. A simple diagram showing the main lobes and regions of the human brain along with the specific location of the prefrontal cortex. Image adapted from Igou (2013).

In early adolescence, large alterations in hormone levels and physical changes occur which are related to the onset of puberty. These significant changes in hormonal events can lead to numerous changes in social, academic and environmental factors experienced in adolescence many of which may influence the education of an adolescent (Blakemore, et al., 2010).

Distinct changes occur within the brain which are especially evident in the prefrontal cortex, an area associated with tasks such as decision making, planning cognitive behaviour, expression of personality and moderating social behaviour (Blakemore, et al., 2010; Carter, 2010; Finn, Sheridan, Kam, Hinshaw, & D'Esposito, 2010). These changes include an increase in the efficiency in which messages can transfer along the neurons within the brain as a result of myelination of neurons and physiological 'pruning' of neurons to remove unnecessary synaptic connections (Blakemore, et al., 2010; Carter, 2010; Dosenbach et al., 2010; Klingberg, et al., 2002).

## **Working Memory and Education**

WM has been shown to be a fundamental part of students' acquisition of new material, active participation in the classroom, remembering instructions given for a task, engaging in mental arithmetic and writing whilst mentally formulating the next part of a text (St Clair-Thompson, et al., 2010). Young children's WM skills are good predictors of literacy and numeracy, perhaps even more so than IQ scores, thus suggesting that WM is a rather more fixed trait than IQ (known to be correlated with socioeconomic status and maternal level of education) (Alloway & Alloway, 2010). Poor WM has been shown to result in poor comprehension and processing of written material, and poor performance in mathematics (Adams & Gathercole, 2000; Daneman & Carpenter, 1980; Phye & Pickering, 2006; Wang & Gathercole, 2013). Given that WM exerts its effects across the lifespan of an individual, identifying and supporting

young children with poor WM skills seems to be warranted. Students not making progress may be subject to assessments for learning difficulties, such as the WISC tests and the Stanford-Binet Intelligence scales as used by school psychologists. Some of these tests may include a WM component, although WM is rarely specifically identified as a factor related to learning difficulties (Naglieri, 2009; O'Donnell, 2009; Phye & Pickering, 2006).

## **Electroencephalography (EEG)**

Due to technologies such as EEG, we can now record the electromagnetic activity of the brain emitted through the scalp to give a clearer understanding of which/when neuroanatomical structures are active during different mental occurrences (Picton et al., 2000).



Figure 2. A Compumedics ‘Quick Cap’ headset as was used in the research for collection of EEG data. Image adapted from Compumedics Neuromedical Supplies (2005).

Using EEG, specific brain waves (especially theta and alpha) have been shown to be distributed across the brain during WM (Kawasaki, et al., 2010). This paper presents research using EEG to obtain a measure of WM of adolescent students based upon the theta wave located in the frontal midline of the scalp (fm $\Theta$ ).

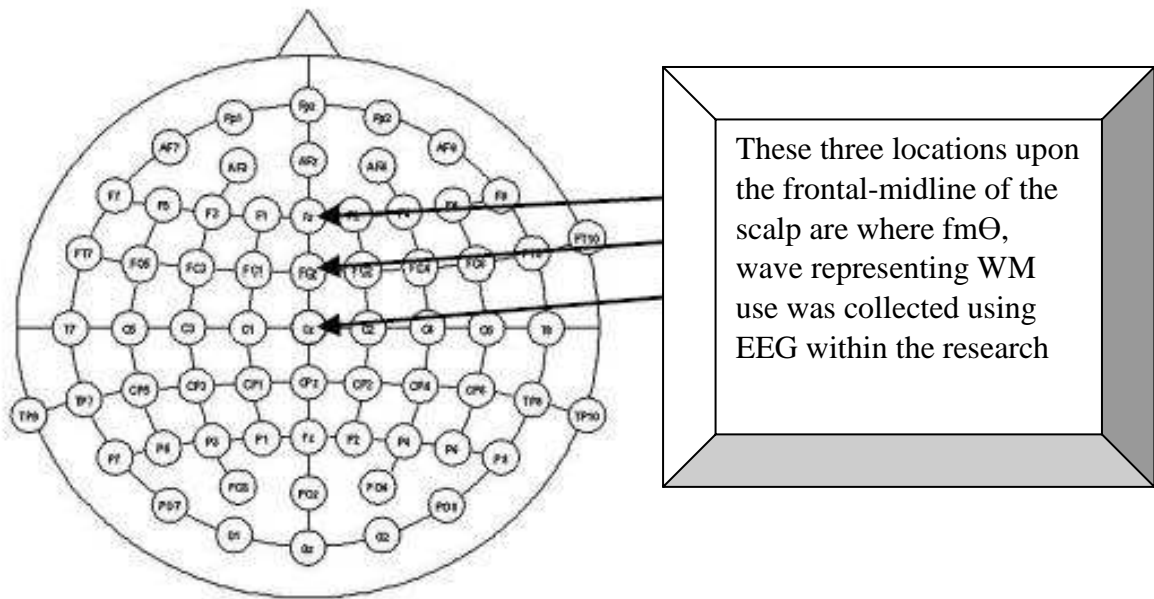

These three locations upon the frontal-midline of the scalp are where  $fm\Theta$ , wave representing WM use was collected using EEG within the research

Figure 3. A map of the locations of possible approximate EEG electrode locations on the human head. The research examined electrical information for  $fm\Theta$  at the three locations indicated (Fz, FCz & Cz) for a measure of WM use. Image adapted from Viklund (2008).

### Introducing the Research

This was conducted as a small scale case study as part of the work for a master’s thesis with a small sample of students at the school of the first author having met ethics’ approval at The University of Western Australia. The research sought to validate the  $fm\Theta$  technique for measurement of WM and determine whether there are differences in WM between older and younger teenagers. Two research questions of the research were as follows:

- Could a measure of WM using EEG be validated with the comparison of results to a traditional WM test?
- Were there differences in WM between older and younger adolescents?

To achieve this, a small exploratory case study was completed to investigate the effects of age on WM in adolescent males. A WM task was given to two groups of adolescent male students while EEG was simultaneously recorded to give two measures of WM, one measure from a traditional WM task and one from EEG.

## **Participants**

The research included 20 male students aged 12-13 and 20 male students aged 15-16 attending a Western Australian Independent Secondary School (n = 40). All participants were students of the first author who was a teacher at the school.

## **Methodology**

The WM task used within the research was a modified Sternberg (1966) task, using 'response time latencies'. The Sternberg task presents a set of stimulus to be stored in WM to the participant, then presents a 'probe' stimulus that the participant is required to recall whether or not was present in the preceding set of stimulus (Sternberg, 1966). The modified Sternberg task along with the EEG recording took place within the school day and took approximately one hour. A 32 channel EEG Compumedics Quick-Cap headset was to be worn by the participant attached to a monopolar digital amplifier to while the modified Sternberg WM task was completed. Electroconductive gel was used to allow for the conduction of electrical activity from the participants' scalps and the accurate measure of WM as EEG. With EEG being recorded, student participants completed a multimedia-based modified Sternberg task on a desktop computer, having to press computer keys to indicate their responses as to whether the probe stimulus was present in a preceding set of stimuli.

## **Results**

Figures 4 and 5 are examples of images from the data collected that give a clear indication that  $fm\Theta$  was produced under conditions where WM was being used by the participant.

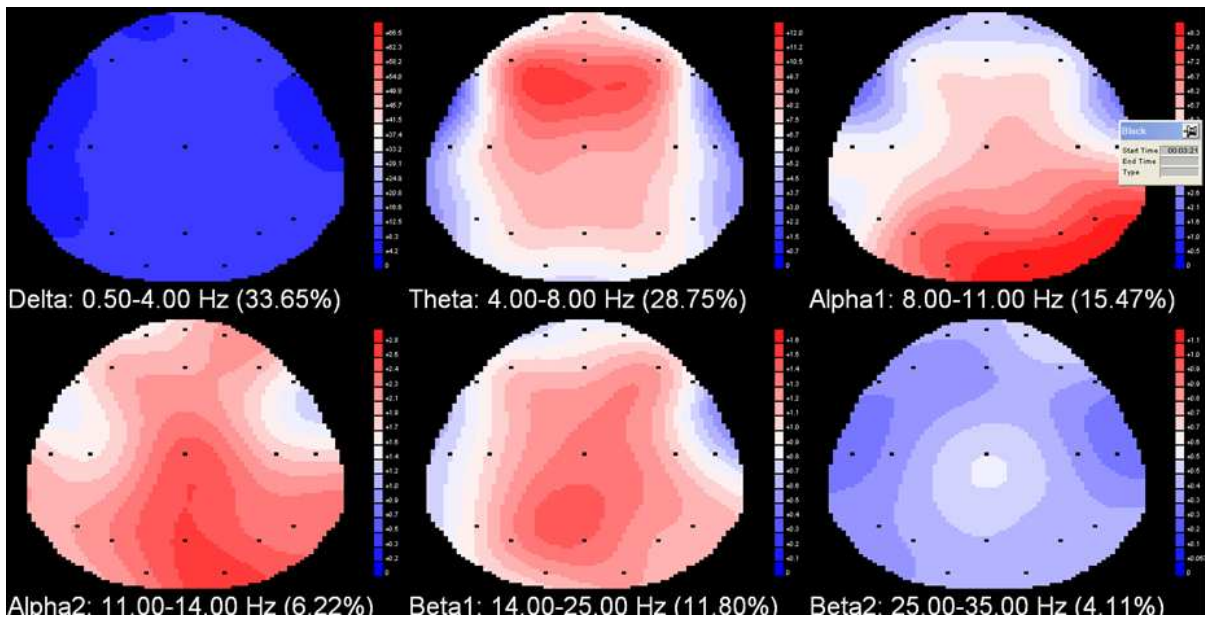

Figure 4. This figure shows an 6 images of the common electrical brainwave activities of different frequencies from a student participant in the research, notice the relatively high measurement of  $\theta$ , indicative of greater WM near the frontal midline of the scalp. The images are produced by a fast Fourier transform average of EEG taken from the time in which WM is in use by the participant.

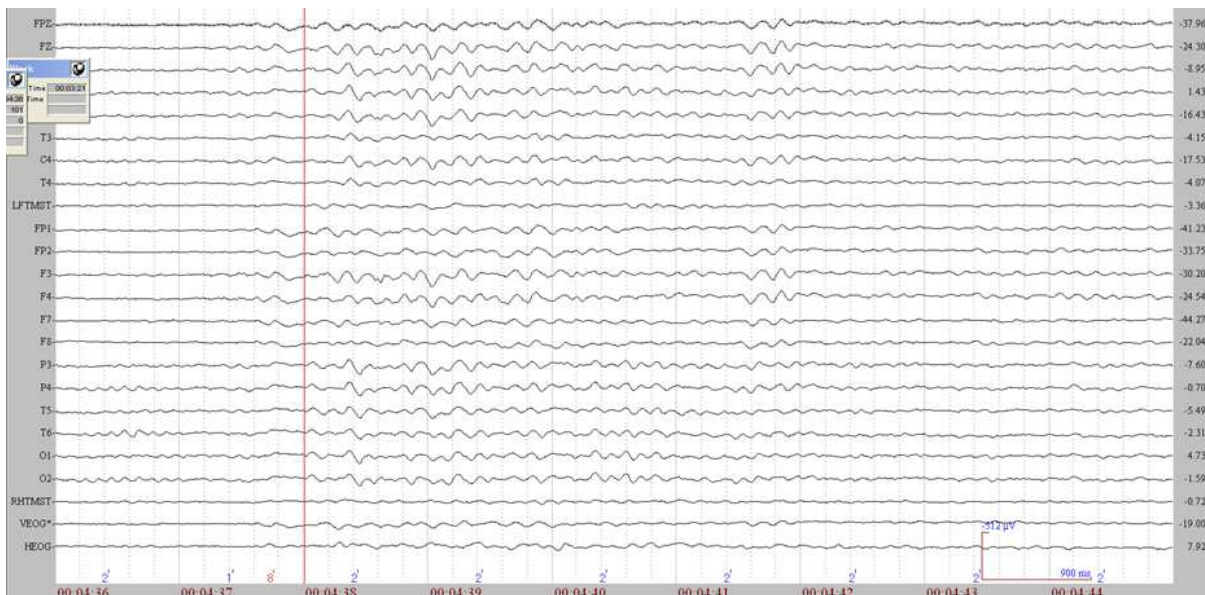

Figure 5. The EEG as recorded from the participants showing the theta wave representative of WM at the time at which data was recorded within the research.

Data were collected and analysed from all participants, then averaged for each of the separate age groups of students. A low, but statistically significant correlation was found between the mean fm $\Theta$  power obtained by EEG and the response-time latency measures of WM as obtained by the modified Sternberg task (see Figure 4). A statistical model for analysis of variance was applied to the data collected to determine whether or not there was a difference in WM between the two adolescent age groups. The results showed that older adolescent students demonstrated higher levels of WM than younger adolescent students with a medium effect size given as the difference in WM between the two age groups (see Figure 5).

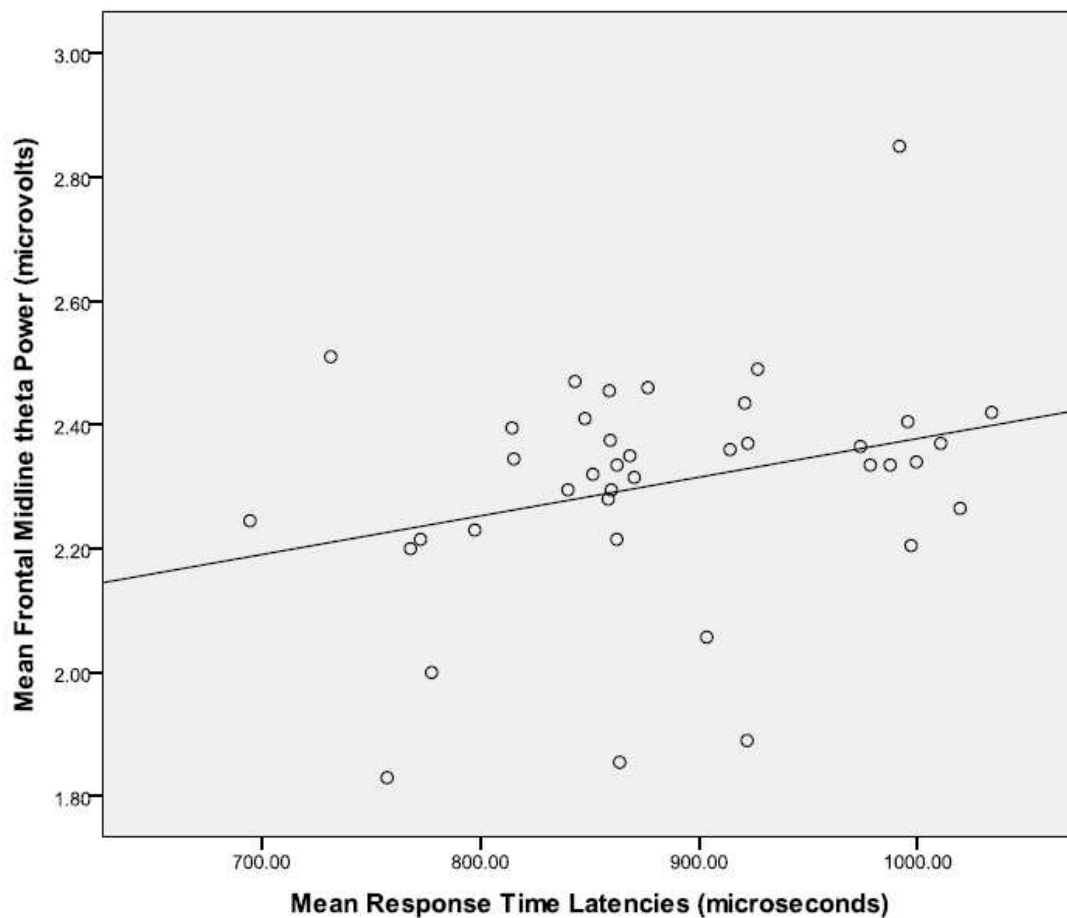

Figure 6. Scatter-plot and regression line between the response time latency and frontal midline theta power dependent variables. These data show a low but positive correlation between the two measures of WM that provides support that both fm $\Theta$  and response time latencies are valid measures of working memory.



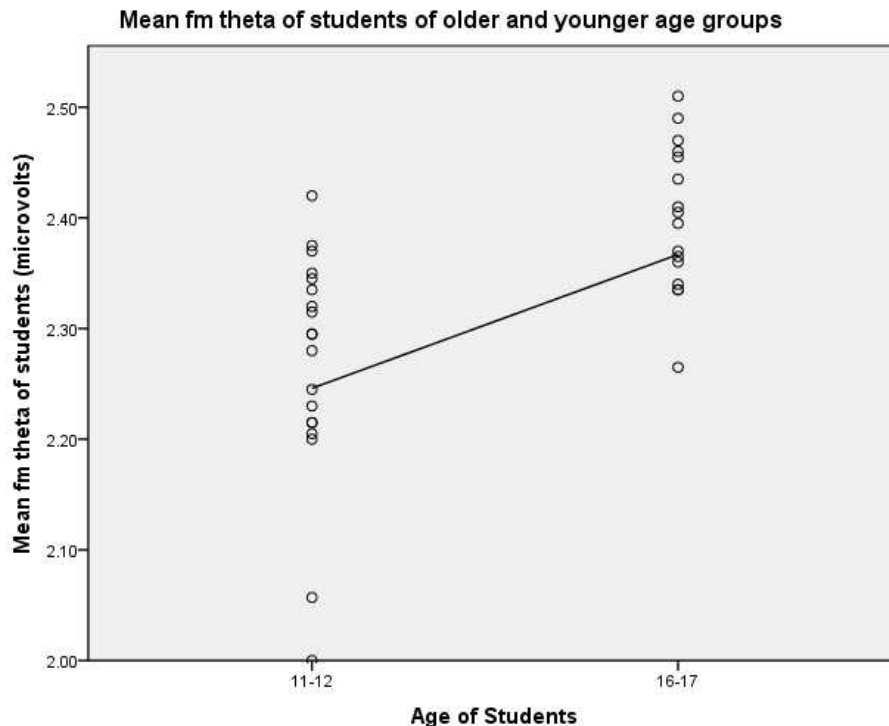

Figure 7. The mean fm $\theta$  of each student age group. The graph indicates that the male students of the older age group showed a greater mean fm $\theta$ , indicative of greater WM.

## Analysis

The results of the research indicated that younger adolescent students had a lower mean fm $\theta$  power as a measurement of WM usage during a modified Sternberg task. The results of the research appeared to validate EEG as a measure of WM. The lower mean measure of fm $\theta$  the younger adolescent students suggests that the restructuring that occurs in the prefrontal cortex of younger adolescent students results in a lower WM than the older adolescents. The data suggests that older adolescent students have completed the restructuring of the prefrontal cortex to a greater extent which has allowed for more efficient transfer of messages associated with WM processes (Carter, 2010; Choudhury, et al., 2008).

While fm $\theta$  representative of WM appears to increase with age in adolescent students this may not be true for students of all ages. Other sources of brain activity not associated with WM can be mistaken for fm $\theta$  activity during EEG in children who have not yet reached adolescence (Mitchell, McNaughton, Flanagan, & Kirk, 2008, 2008). Findings from the research presented here suggest a long-term longitudinal study in adolescents using fm $\theta$  as a measure of WM would be helpful. Samples in such a study could be taken from annually

from adolescents throughout their entire adolescent period to give a greater insight into WM development over time with a simultaneous study of prefrontal cortex development.

Similarly, the variable of gender as well as age could be considered in future studies of WM measured by  $fm\Theta$ . It is well understood that frontal lobe grey matter peaks at different ages for males and females during the teenage years (Choudhury, et al., 2008). With a simple means to determine the stages of prefrontal reorganisation and an immediate relationship to WM processes, future research could examine whether the peaks in frontal lobe grey matter between males and females has a measureable influence on WM processes. In the research undertaken here, only male students participated for pragmatic purposes, and including females in the study would be a next step as well as students older and younger than early and mid-adolescents.

## **Relating the Research to Education**

These results highlight the differences in WM that exist between adolescents of two different age groups. It has shown that WM increases with age and how this may be related to neurological development that occurs during adolescence. Increases in WM are almost intuitively exploited by teachers as they (and the curriculum) place greater cognitive demands on older students. Some students, however, seem to persistently struggle at school and their scholastic achievements limited by their WM capacity.

Deficiencies in WM could be addressed by schools with the adoption of helpful strategies for use by teachers within the classroom including techniques related to the reduction in the amount of material presented both verbally and visually to students and increasing the meaningfulness and familiarity of the material presented to students (Gathercole, 2008). These guidelines can often take the form of simple learning tools that can be integrated into classroom materials to assist students with limited WM such as younger adolescents. Teachers may reduce the load upon the working memory of their students by simplifying the format and presentation of information in lessons especially in learning areas involving reading comprehension and mathematics (Holmes & Gathercole, 2013). Having greater WM, older students may be more capable of strategic self-organisation, and teachers could be

encouraged to take advantage of this within the classroom. For example, as teachers of older adolescents introduce concepts or new topics, they ask students what they already know about related topics or events as a way of both focusing students on a new topic, gaining attention and eliciting students' responses and thoughts. In this way, teachers develop and use metacognition related to what is already 'stored' in WM. Metacognitive thinking has been shown to have a positive impact in many areas of education including standardised testing, reading comprehension and writing and has been shown to be useful as a strategy for maximising WM within students (see, for example, Goswami & Bryant, 2007).

Could teachers structure lessons or teaching and learning programs differently to account for differences in WM? Is it possible to accommodate the different WM needs of students through individualized education programs? Are teachers (and pre-service teacher educators) aware of differences in WM in school students? Is this sort of knowledge about child development or educational neuroscience included as part of a teacher education program in Australia? Given that the focus of most teachers will be the students they teach, it would be reasonable to expect that they are most fully briefed about the students in their classrooms and better understand how to support learning of all. In the future, perhaps teachers would have access not only to NAPLAN scores, but also information about attention, WM and general motivation. Whilst educational neuroscience has yet to reach teacher education in Australia, the interest in brains and learning has provided opportunities for neuromyths to flourish and programs to be introduced into schools, advertised as 'brain-based' that lack both science and evidence for their effectiveness (Oliver, 2011).

WM appears to be a misunderstood quantity that is not effectively considered within schools as a limiting factor for the effective education of students. This research has demonstrated how WM can be measured in adolescent students using EEG and that the differences in WM exist in male students of different ages. It is hoped that by highlighting the nature of WM as a process that develops throughout the age of a student and the importance of WM for effective learning, teachers may be interested to reflect on the potential and limitation of students' WM in our classrooms.

**EXTRA INFORMATIVE BOX IDEA.**

Teachers increasingly understand the value of teaching their students how they think. The functionality of new computer based multimedia and the accessibility of the internet may provide teachers with resources that may promote attention, working memory and , are simple to use and easily adapted to the classroom.

Educational Neuroscience programs are being developed that may assist in students gaining an understanding of their brain function. Two such educational neuroscience programs developed in the US are *BrainU* (<http://brainu.org/resources/MNSTDS>) and *Neuroscience for Kids* (<http://faculty.washington.edu/chudler/neurok.html>).

The Sternberg test, as has been adapted by the research to obtain a measure of working memory is available online at *Millisecond Software* (<http://www.millisecond.com/download/library/Sternberg/https://faculty.washington.edu/chudler/java/ready.html>)

The Stroop test is widely used in psychological fields as a demonstration of interference in the reaction time of a task and is available from the *University of Washington* with no specialized equipment. (<https://faculty.washington.edu/chudler/java/ready.html>)

<http://www.psychologytoday.com/blog/fulfillment-any-age/201206/the-13-top-online-psychology-games>

Annable, J. (2012). Becoming self-editors: Using metacognition to improve students' grammar knowledge. *English Journal*, 101(3), 89-91.

Goswami, U., & Bryant, P. (2007). Children's cognitive development and learning. In R. Alexander, C. Doddington, J. Gray, L. Hargreaves & R. Kershner (Eds.), *The Cambridge Primary Review Research Surveys*, London: Routledge.

Hughes, C. (1998). Executive function in preschoolers: Links with theory of mind and verbal ability. *British Journal of Developmental Psychology*, 16(2), 233-253.

Zohar, A., Dori, Y, J. (2012) *Metacognition in Science Education*, Dordrecht: Springer, 2012.

Teachers increasingly understand the value of teaching their students how they think. The functionality of new computer based multimedia and the accessibility of the internet may provide teachers with resources that may improve attention and working memory. For example, see the Cogmed program at <http://www.cogmed.com/about-working-memory>

Educational Neuroscience programs are being developed that may assist in students gaining an understanding of their brain function. Two such educational neuroscience programs developed in the US are *BrainU* (<http://brainu.org/resources/MNSTDS>) and *Neuroscience for Kids* (<http://faculty.washington.edu/chudler/neurok.html>).

The Sternberg test, as has been adapted by the research to obtain a measure of working memory is available online at *Millisecond Software* (<http://www.millisecond.com/download/library/Sternberg/https://faculty.washington.edu/chudler/java/ready.html>)

The Stroop test is widely used in psychological fields as a demonstration of interference in the reaction time of a task and is available from the *University of Washington* with no specialized equipment. (<https://faculty.washington.edu/chudler/java/ready.html>)

<http://www.psychologytoday.com/blog/fulfillment-any-age/201206/the-13-top-online-psychology-games>

- Adams, A., & Gathercole, S. (2000). Limitations in working memory: Implications for language development. *International Journal of Language & Communication Disorders*, 35(1), 95-116.
- Alloway, T. P., & Alloway, R. G. (2010). Investigating the predictive roles of working memory and IQ in academic attainment. *Journal of Experimental Child Psychology*, 106(1), 20-29.
- Alloway, T. P., Gathercole, S. E., Kirkwood, H., & Elliott, J. (2008). Evaluating the validity of the Automated Working Memory Assessment. *Educational Psychology*, 28(7), 725-734.
- Annable, J. (2012). Becoming self-editors: Using metacognition to improve students' grammar knowledge. *English Journal*, 101(3), 89-91.
- Baddeley. (2003). Working memory: Looking back and looking forward. *Nature Reviews Neuroscience*, 4(10), 829-839.
- Blakemore, S.-J., Burnett, S., & Dahl, R. E. (2010). The role of puberty in the developing adolescent brain. *Human Brain Mapping*, 31(6), 926-933.
- Buzsáki, G. (2006). *Rhythms of the Brain* (pp. 277-333). New York: Oxford University Press.
- Carter, R., Frith, C. (2010). *Mapping the Mind*. Berkeley: University of California Press.
- Choudhury, S., Charman, T., & Blakemore, S.-J. (2008). Development of the teenage brain. *Mind, Brain & Education*, 2(3), 142-147.
- Compumedics Neuromedical Supplies. (2005) Compumedics Neuromedical Supplies Online Catalog Retrieved 20 June, 2014 from [www.neuroscan.com](http://www.neuroscan.com)
- Crone, E. A., Wendelken, C., Donohue, S., Leijenhors, L. v., & Bunge, S. A. (2006). Neurocognitive development of the ability to manipulate information in working memory. *Proceedings of the National Academy of Sciences of the United States of America*, 103(24), 9315-9320.
- D'Esposito, M. (2007). From cognitive to neural models of working memory. *Philosophical Transactions: Biological Sciences*, 362(1481), 761-772.
- Daneman, M., & Carpenter, P. A. (1980). Individual differences in working memory and reading. *Journal of Verbal Learning and Verbal Behavior*, 19(4), 450-466.

- Dosenbach, N. U. F., Nardos, B., Cohen, A. L., Fair, D. A., Power, J. D., Church, J. A., et al. (2010). Prediction of individual brain maturity using fMRI. *Science*, 329(5997), 1358-1361.
- Dubinsky, J., Roehrig, G., Varma, S. (2013) Infusing Neuroscience Into Teacher Professional Development. *Educational Researcher*, 42 317-329.
- Finn, A. S., Sheridan, M. A., Kam, C. L. H., Hinshaw, S., & D'Esposito, M. (2010). Longitudinal evidence for functional specialization of the neural circuit supporting working memory in the human brain. *The Journal of Neuroscience*, 30(33), 11062-11067.
- Fry, A., & Hale, S. (1996). Processing Speed, Working Memory, and Fluid Intelligence: Evidence for a Developmental Cascade. *Psychological Science*, 7 (4), 237-241
- Gathercole, S., Packiam Alloway, T. (2008). *Working Memory and Learning: A Practical Guide for Teachers*. Los Angeles: SAGE Publications
- Goswami, U., & Bryant, P. (2007). Children's cognitive development and learning. In R. Alexander, C. Doddington, J. Gray, L. Hargreaves & R. Kershner (Eds.), *The Cambridge Primary Review Research Surveys*, London: Routledge.
- Holmes, J., & Gathercole, S. E. (2013). Taking working memory training from the laboratory into schools. *Educational Psychology*, 111.
- Hughes, C. (1998). Executive function in preschoolers: Links with theory of mind and verbal ability. *British Journal of Developmental Psychology*, 16(2), 233-253.
- Hsieh, L & Ranganath, C. (2014) Frontal midline theta oscillations during working memory maintenance and episodic encoding and retrieval. *Neuroimage*. 85(2), 721-729
- Igou, S. (2013). Brain Injury Retrieved 16 October, 2013 from [www.braininjury.com](http://www.braininjury.com)
- Kawasaki, M., Kitajo, K., & Yamaguchi, Y. (2010). Dynamic links between theta executive functions and alpha storage buffers in auditory and visual working memory. *European Journal of Neuroscience*, 31(9), 1683-1689. 79
- Klingberg, T., Forssberg, H., & Westerberg, H. (2002). Increased brain activity in frontal and parietal cortex underlies the development of visuospatial working memory capacity during childhood. *Journal of Cognitive Neuroscience*, 14(1), 1-10.

- Kropotov, J. (2009). *Quantitative EEG, Event-Related Potentials and Neurotherapy* (pp. 77-95). San Diego, Burlington, London: Academic Press.
- Luciana, M., Conklin, H. M., Hooper, C. J., & Yarger, R. S. (2005). The development of nonverbal working memory and executive control processes in adolescents. *Child Development*, 76(3), 697-712.
- Mitchell, D. J., McNaughton, N., Flanagan, D., & Kirk, I. J. (2008). Frontal-midline theta from the perspective of hippocampal "theta". *Progress in Neurobiology*, 86(3), 156-185.
- Naglieri, J., & Goldstein, S. (2009). *Practitioner's Guide to Assessing Intelligence and Achievement* Hoboken: Wiley.
- Niedermeyer, E., Naidu, S. B., & Plate, C. (1997). Unusual EEG theta rhythms over central region in Rett Syndrome: Considerations of the underlying dysfunction. *Clinical EEG and Neuroscience*, 28(1), 36-43.
- O'Donnell, L. (2009). *The Wechsler intelligence scale for children - Fourth edition. Practitioner's Guide to Assessing Intelligence and Achievement*(7), 153-190.
- Oliver, M. (2011). Towards an understanding of neuroscience for educators. *Studies in Science Education*. 47(2), 207-231.
- Owen, A. M., Evans, A. C., & Petrides, M. (1996). Evidence for a two-stage model of spatial working memory processing within the lateral frontal cortex: A positron emission tomography study. *Cerebral Cortex*, 6(1), 31-38.
- Sauseng, P., Griesmayr, B., Freunberger, R., & Klimesch, W. (2010). Control mechanisms in working memory: A possible function of EEG theta oscillations. *Neuroscience & Biobehavioral Reviews*, 34(7), 1015-1022.
- Schneider, W. (2008). Memory Development. In U. Goswami (Ed.), *Blackwell Handbook of Childhood Cognitive Development* (pp. 236-256). Malden: Blackwell Publishers.
- Shiffrin, R., & Schneider, W. (1977). Controlled and automatic human information processing: II. Perceptual learning, automatic attending, and a general theory. *Psychological Review*, 84(2), 127-190.



- Smith, E. E., & Jonides, J. (1997). Working Memory: A view from neuroimaging. *Cognitive Psychology*, 33(1), 5-42. 86.
- St Clair-Thompson, H., Stevens, R., Hunt, A., & Bolder, E. (2010). Improving children's working memory and classroom performance. *Educational Psychology*, 30(2), 203-219.
- Viklund, A. (2008). Clinical Neuroscience Research Team (University of Surrey) Retrieved 20 February, 2011, from <http://www.fahs.surrey.ac.uk/cnrt/facilities/eeg.html>
- Wang, S., & Gathercole, S. E. (2013). Working memory deficits in children with reading difficulties: Memory span and dual task coordination. *Journal of Experimental Child Psychology*, 115(1), 188-197.
- Woo, T. U., Pucak, M. L., Kye, C. H., Matus, C. V., & Lewis, D. A. (1997). Peripubertal refinement of the intrinsic and associational circuitry in monkey prefrontal cortex. *Neuroscience*, 80(4), 1149-1158.
- Zohar, A., & Dori, Y. J. (2012) *Metacognition in Science Education*, Dordrecht: Springer, 2012.