



Khalifa, Najat Rasool (2012) The link between conduct disorder and adult antisocial behaviour is partially mediated by early onset alcohol abuse. DM thesis, University of Nottingham.

Access from the University of Nottingham repository:

http://eprints.nottingham.ac.uk/12563/1/Link_between_conduct_disorder_%26_adult_antisocial_behaviour_DM_Thesis_N_Khalifa__2012.pdf

Copyright and reuse:

The Nottingham ePrints service makes this work by researchers of the University of Nottingham available open access under the following conditions.

- Copyright and all moral rights to the version of the paper presented here belong to the individual author(s) and/or other copyright owners.
- To the extent reasonable and practicable the material made available in Nottingham ePrints has been checked for eligibility before being made available.
- Copies of full items can be used for personal research or study, educational, or not-for-profit purposes without prior permission or charge provided that the authors, title and full bibliographic details are credited, a hyperlink and/or URL is given for the original metadata page and the content is not changed in any way.
- Quotations or similar reproductions must be sufficiently acknowledged.

Please see our full end user licence at:

http://eprints.nottingham.ac.uk/end_user_agreement.pdf

A note on versions:

The version presented here may differ from the published version or from the version of record. If you wish to cite this item you are advised to consult the publisher's version. Please see the repository url above for details on accessing the published version and note that access may require a subscription.

For more information, please contact eprints@nottingham.ac.uk

**THE LINK BETWEEN CONDUCT DISORDER AND ADULT ANTISOCIAL
BEHAVIOUR IS PARTIALLY MEDIATED BY EARLY ONSET ALCOHOL
ABUSE**

NAJAT RASOOL KHALIFA, *MBChB, MRCPsych, CCT*

**Thesis submitted to the University of Nottingham for
the degree of Doctor of Medicine**

JULY 2012

**Research Conducted at
The Section of Forensic Mental Health,
School of Community Health Sciences,
The University of Nottingham**

Supervisors:

Dr Richard Howard

Professor Conor Duggan

Examiners:

Dr Birgit Völlm

Professor Christopher Patrick

ABSTRACT

This study sought to clarify the nature of the relationship between conduct disorder (CD), early-onset alcohol abuse (EOAA), some other externalizing-related constructs and adult violent antisociality (VA). It addressed two key questions: (i) whether EOAA mediated the link between CD and VA; and (ii) whether the effects of EOAA on VA were, in turn, mediated by impulsiveness, ventro-medial prefrontal cortex (vm-PFC) dysfunction and social deviance as measured by the Psychopathy Checklist-Revised (PCL-R). It tested the hypothesis that in the context of early disinhibitory psychopathology, e.g. CD, EOAA disrupts the neural substrates of self-regulation in vm-PFC during a critical neurodevelopmental period (i.e. before age 20). Consequently, on entry into adulthood the vm-PFC is functionally impaired and personality suffers maladaptive development which would then take the form of increased impulsiveness and social deviance, placing the individual at high risk of violent antisocial behaviour.

Using a cross sectional design, DSM-IV Axis I and II disorders, psychopathy, impulsiveness, vm-PFC functioning, history of drug and alcohol use, and both amount and severity of violence were assessed in 100 patients with personality disorders detained in secure hospital settings. Patients identified as having a history of EOAA, compared with those with no alcohol abuse history, were more impulsive, scored higher on the social deviance factor of psychopathy (PCL-R F2), were more conduct disordered, and showed a higher level of VA. Regression analysis showed that CD, EOAA, impulsiveness and PCL-R F2 significantly predicted VA, although PCL-R F2 rendered the effects of CD insignificant when used conjointly in regression analysis.

A multiple mediation model explaining about 20% of the variance in VA showed that EOAA partially mediated the effects of CD on VA, after controlling for age, cannabis misuse and ADHD. A separate multiple mediation model explaining 50% of the variance in VA showed that PCL-R F2 and impulsiveness partially mediated the effect of EOAA on VA. However, contrary to the prediction arising from the hypothesis, the effects of vm-PFC functioning on VA were insignificant. Although the study suffered from some limitations, results suggest that both impulsiveness and social deviance contribute importantly to a pathway leading from CD through adolescent alcohol abuse to maladaptive personality development and adult VA.

LIST OF PUBLISHED PAPERS

Khalifa, N., Lumsden, J., Duggan, C. & Howard, R. The relationship between childhood conduct disorder and adult antisocial behaviour is partially mediated by early onset alcohol abuse. *Personality Disorder: Theory, Research and Treatment* (in press).

Howard, R., Khalifa, N., Duggan, C., & Lumsden, J. (2012). Are patients deemed "dangerous and severely personality disordered" different from other personality disordered patients detained in forensic settings? *Criminal Behaviour and Mental Health*, 22 (1), 65-78.

ACKNOWLEDGEMENTS

I would like to thank all participants for their cooperation and individuals who have made a contribution to this study; especially I am greatly indebted to the following individuals:

1. Professor Conor Duggan who in addition to introducing me to the world of academia has been a great source of support over the years from when I was his lecturer to present date. He is a man of great humility, fairness and transparency.
2. Dr Richard Howard without whose help and dedication this thesis wouldn't have seen the light. He has not only taught me the ABCs of neuropsychology of offending behaviour, but also helped me to develop my critical thinking skills. I admire his analytical and sophisticated way of thinking.
3. Dr. John Lumsden for his generous hospitality and help with recruitment of participants and data collection at Broadmoor hospital.
4. Victoria Owen for her invaluable advice with regards to statistics which she gave generously and out of good will.

Funding:

This work was supported by the 'New Lecturers' Grant' awarded by the Research Innovation Services at the University of Nottingham, UK

DECLARATION

No part of this thesis has been submitted in support of an application for another academic degree or qualification neither at the University of Nottingham nor any other academic institutions.

ABOUT THE AUTHOR

Najat Khalifa *MBChB, MRCPsych, CCT (Forensic Psychiatry)* is a Consultant Forensic Psychiatrist in Nottinghamshire Healthcare NHS Trust and Special Lecturer at the University of Nottingham. His research interests are personality disorder and offending behaviour, religion and mental health and the neurobiology of offending behaviour. He also has an interest in the psychophysiology of offending behaviour. He was a co-investigator in a multi-site ERP study. He has published a number of academic articles on the professional practice of forensic psychiatry, personality disorder and offending behaviour and co-authored a book (McMurrin, Khalifa & Gibbon, *Forensic Mental Health*, 2009. Willan Publishing). He was the lead author for a Cochrane systematic review on the use of pharmacological interventions in people with antisocial personality disorder. The list of his publications is provided in appendix IX.

LIST OF ABBREVIATIONS

ASB	Adult Antisocial Behaviour
ACC	Anterior Cingulate cortex
ADHD	Attention Deficit Hyperactivity Disorder
APD	Antisocial Personality Disorder
BPD	Borderline Personality Disorder
CD	Conduct Disorder
C-DIS	Computerized Diagnostic Interview Schedule for DSM
DBD	Disruptive Behavior Disorders
DL-PFC	Dorso-lateral Prefrontal Cortex
DSM-III	Diagnostic and Statistical Manual of Mental Disorders- Third Edition
DSM-IV	Diagnostic and Statistical Manual of Mental Disorders- Fourth Edition
DSPD	Dangerous and Severe Personality Disorder
DV	Dependent Variable
EOAA	Early Onset Alcohol Abuse
EEG	Electroencephalography
ERP	Event Related Potential
ERV	Externalizing-Related Variables
GCSE	General Certificate of Secondary Education
ICD 10	International Classification of Diseases-Tenth Edition
IGT	Iowa Gambling Task
IV	Independent Variable
LCP	Life Course Persistent Offenders
IPDE	International Personality Disorder Examination
MRI	Magnetic Resonance Imaging
ODD	Oppositional Deviant Disorder
OLS	Ordinary Least Squares
PCL-R	Psychopathy Checklist-Revised
PD	Personality Disorder
PICU	Psychiatric Intensive Care Unit
SD	Standard Deviation
VA	Violent Antisociality
Vm-PFC	Ventro-medial Prefrontal Cortex
VSRS	Violence Severity Rating Scale
UPPS	Urgency, Premeditation, Perseverance, Sensation Seeking Impulsiveness Scale
WAIS	Wechsler Adult Intelligence Scale

LIST OF FIGURES AND IMAGES

	<i>Page</i>
Figure 1: Schematic representation of the hypothesis	51
Image 1: Iowa Gambling Task screen image	61
Figure 2: Mediation and Moderation Models	72
Figure 3: Performance on IGT by group	88
Figure 4: Multiple Mediation Model 1	90
Figure5: Multiple Mediation Model 2	98

LIST OF TABLES

	<i>Page</i>
Table 1: Inclusion and exclusion criteria	55
Table 2: Comparison by site	79
Table 3: Comparisons between PD and DSPD groups on offending, personality and clinical variables	82
Table 4: Comparison by history of alcohol abuse	85
Table 5A: Inter-correlations between externalizing related measures	92
Table 5B: Inter-correlations between externalizing related measures, and historical variables including criminal offending	93
Table 6: Results of the multiple regression analysis	94
Table 7: Moderation models for the effects of moderating variables on VA	95
Table 8: Mediation models of the effects of externalizing measures (EOAA, IGT, PCL F2, UPPS), using VA as dependent variable.	97

LIST OF CONTENTS

	<i>Page</i>
ABSTRACT	2
LIST OF PUBLISHED PAPERS	4
ACKNOWLEDGMENTS	5
DECLARATION	6
ABOUT THE AUTHOR	7
LIST OF ABBREVIATIONS	8
LIST OF FIGURES AND IMAGES	9
LIST OF TABLES	10
CHAPTER ONE: INTRODUCTION	14
A. Overview	14
B. Personality Disorder and Violence	15
C. Psychopathy	20
D. Externalizing	25
E. Conduct Disorder	26
F. Early Onset Alcohol Abuse	29
G. Impulsiveness	32
H. Do Individuals With APD Show A Frontal Lobe Dysfunction?	34
I. Development of Antisocial Behaviour From Childhood	39
J. The "How" Question	42
K. Forensic Mental Health Services	44
CHAPTER TWO: STUDY HYPOTHESIS	
A. The Hypothesis	50
B. Significance of The Hypothesis	50
C. Testing the Hypothesis	51
CHAPTER THREE: METHOD	
A. The Sample	53
1. Study Participants	53
2. Inclusion and Exclusion Criteria	54
B. Procedure and Instruments	55
1. Perusal of Case-Files	55
2. Assessment of Psychopathology and Violence	55
2.1 Assessment of Axis I Disorders	56
2.2 Illicit Drug and Alcohol Use History	56
2.3 Assessment of Personality Disorder	57
2.4 Assessment of Psychopathy	58
2.5 Assessment of Violence	59
2.6 Assessment of Impulsiveness	60
2.7 Ventro-medial Pre-Frontal Cortex Dysfunction	60
C. Data Analysis	62
1. Key Variables	
1.1 Conduct Disorder	62
1.2 Early Onset Alcohol Abuse	63
1.3 Vm-PFC Dysfunction	64
1.4 UPPS Impulsiveness	65
1.5 Psychopathy	65
1.6 Violent Antisociality	65
2. Missing Data	66

3. Analytic Strategy	67
3.1 Stage One: Preliminary Analysis	67
3.2 Stage two: Testing The Hypothesis	68
D. Ethics and Consent	74

CHAPTER FOUR: RESULTS

A. Sample Characteristics	75
1. General	75
2. Socio-Demographics	75
3. Psychopathology and Substance Misuse	76
4. Key Variables	76
1.1 CD	76
1.2 EOAA	77
1.3 Psychopathy	77
1.4 IGT	77
1.5 VA	77
1.6 UPPS	78
B. Comparison By Site	78
C. Do DSPD patients differ from PD patients in terms of their clinical characteristics?	81
D. Testing The Hypothesis	84
1. Between Groups Comparison	84
2. Did Early Onset Alcohol Abuse Moderate The Effect of CD On Violent Antisociality?	88
3. Did Early Onset Alcohol Abuse Mediate The Effect of CD On Violent Antisociality?	89
4. Relationships Between Externalizing-Related Variables (ERVs) and Between ERVs and Other Variables.	89
5. Which Measures of Externalizing Best Predicted Violent Antisociality?	90
6. Did Externalizing-Related Variables Moderate The Link Between EOAA and Violent Antisociality?	94
7. Did Externalizing-Related Variables Mediate The Link Between EOAA and Violent Antisociality?	96

CHAPTER FIVE: DISCUSSION AND CONCLUSIONS

A. Discussion	99
1. Sample Characteristics	100
2. Comparisons By Site	101
3. Did Patients Admitted To DSPD Units Represent A Distinct Group?	102
4. Did Patients With EOAA History Differ From Those Without Such A History On Externalizing-Related Variables?	102
5. Did EOAA Mediate The Effects Of CD On Violent Antisociality?	103
6. Which of Several Externalizing-Related Variables Best Accounts For The Relationship Between EOAA and VA In Adulthood?	105
B. Limitations	111
C. Summary and Conclusions	113
D. Implications	113
E. Directions For Future Research	114

REFERENCES	115
-------------------	------------

APPENDICES	145
A. Appendix I: Drug and Alcohol Assessment Protocol (Lumsden et al, 2005)	145
B. Appendix II: Personality Disorder Severity Scale (Tyrer & Johnson, 1996)	149
C. Appendix III: Forensic History	150
D. Appendix IV: Violence Severity Rating Scale (Gunn & Robertson, 1976)	152
E. Appendix V: UPPS Impulsive Behaviour Scale (Whiteside & Lynam, 2001)	153
F. Appendix VI: Iowa Gambling Task (Bechara, 2007)	155
G. Appendix VII: Patient Information Sheet	156
H. Appendix VIII: Consent Form	158
I. Appendix IX: List of Author's Publications	159

CHAPTER ONE

INTRODUCTION

A. Overview

Some personality disorders are associated with an increased risk for violence, with higher rates of violence being reported in individuals with Cluster B personality disorders (antisocial, borderline, histrionic and narcissistic) and, in particular, a strong relationship seems to exist between antisocial personality disorder (APD) and violence (Nestor, 2002; Coid, Yang, Roberts, Ullrich, Moran, Bebbington et al., 2006a). For instance, the British household survey revealed that individuals with a cluster B personality disorder were 10 times more likely to have a criminal conviction compared with those without. In contrast, individuals with cluster A (paranoid, schizoid, schizotypal) and cluster C (obsessive-compulsive, dependent and avoidant) personality disorders were no more violent than the general population (Coid, J., Yang, M., Roberts, A., Ullrich, S., Moran, P., Bebbington et al., 2006b).

Whilst the link between some personality disorders and violence appears impressive, the mechanisms which mediate the link between personality disorder (PD) and violence are poorly understood and have remained controversial (e.g., see McMurran & Howard, 2009). Using a cross sectional design, this study set out to examine a putative mechanism to explain the link between PD and violence in a sample of hospitalised offenders with PD detained in hospital at medium and high levels of security. The study aimed to test a novel hypothesis that the link between PD and violence is partially mediated by early onset alcohol abuse (EOAA) which is hypothesised to mediate the link

between childhood disinhibitory psychopathology, particularly childhood conduct disorder (CD), and adult antisocial behaviours (ASB) including violence (Howard, 2006; 2009; see also chapter 2). It also examined how EOAA was related to violence, PD and a number of conceptually overlapping constructs related to PD, including psychopathy (Hare, 2003), ventro-medial prefrontal cortex (vm-PFC) dysfunction (Bechara, Damasio, Damasio & Anderson, 1994) and impulsiveness (Jolliffe & Farrington, 2009; Lejuez, Magidson, Mitchell, Sinha, Stevens & de Wit, 2010).

The thesis is presented in five major chapters: chapter one, *Introduction*; chapter two, *Study Hypothesis*; chapter three, *Method*; chapter four, *Results*; and chapter five, *Discussion and Conclusions*. In the first section of the introduction chapter, *Personality Disorder and Violence*, a brief overview of PDs is presented along with a critique of the supposed link between PD and violence. In the subsequent sections the roles of EOAA and a number of conceptually overlapping constructs related to PD, including psychopathy, conduct disorder (CD), vm-PFC dysfunction and impulsiveness are discussed. Additionally, a brief overview of the literature on development of antisocial behaviour from childhood is presented. In the final section, *Forensic Mental Health Services*, a brief overview of the population of secure mental health services in England and Wales is presented. The aim is to help contextualise the findings of this study by describing the population from which the study sample was drawn.

B. Personality Disorder and Violence

The term personality encompasses emotions, cognitions and behaviour. It refers to characteristic ways of feeling, thinking and acting in an

individual in a variety of situations over the lifespan. Personality disorder is a diagnostic term used in major psychiatric classification systems, such as the International Classification of Diseases – Tenth Edition (ICD-10; World Health Organisation, 1992) and DSM-IV (American Psychiatric Association, 1994), to describe individuals whose difficulties may be related to these characteristic ways of feeling, thinking and acting. DSM-IV defines personality disorder as:

“An enduring pattern of inner experience and behaviour that deviates markedly from the expectations of the individual’s culture, is pervasive and inflexible, has an onset in early adolescence or early adulthood, is stable over time and leads to distress or impairment” (p.629).

As may be seen from this definition, the disorder is pervasive, persistent and problematic. Therefore, these factors should be taken into consideration and not just how the patient is currently presenting when assessing individuals for PD. Such an assessment may be conducted using standardised diagnostic tools (Duggan & Gibbon, 2008) such as the International Personality Disorder Examination (IPDE; Loranger, 1997). DSM-IV personality disorders (of which 10 specific types are listed apart from PD not otherwise specified) can be arranged into three clusters: Cluster A, the odd or eccentric; Cluster B, the dramatic; and Cluster C, the anxious and fearful. It has been suggested that those patients with PDs involving more than one cluster may be regarded as having severe PD (Tyrer & Johnstone, 1996), although the concept of PD severity has remained controversial.

PDs, in particular APD, have been associated with a range of undesirable outcomes including: relationship difficulties,

unemployment, criminality and homelessness (Harris & Barraclough, 1998; Home Office and Department of Health, 1999; Paris, 2003). Further, the presence of PD is regarded as a negative prognostic factor in those who develop a mental illness (Reich & Vasile, 1993). Additionally, men aged 40 or less with APD are 33 times more likely to die prematurely than those without APD (Martin et al., 1985; Black, Baumgard, Bell & Kao, 1996).

The British household survey found a prevalence of PD of 4.4% in the general population (Coid et al., 2006a), with higher rates of PD being reported in men, the unemployed, those who were separated or divorced and those living in urban areas. The prevalence rates for specific personality disorders ranged between 0.06% and 1.9%, with obsessive-compulsive PD being the most common PD. Whilst estimates of the prevalence of APD differ across studies, prevalence of greater than 1% in the general population has been reported by most studies (Moran, 1999). It is more prevalent in men. Its prevalence is reported to be much higher in prison populations - 31% and 49% in female and male sentenced prisoners respectively (Fazel & Danesh, 2002). It is also reported that APD in men and borderline personality disorder (BPD) in women are over-represented among criminal populations (Fazel & Danesh, 2002).

A number of follow up studies of patients discharged from secure hospital settings showed that people with PD re-offend more frequently and more rapidly than those with mental illness once they are discharged into the community. For instance, in a follow up study of patients discharged from 7 medium secure hospitals in England and Wales, Coid, Hickey, Kahtan, Zhang, & Yang, (2007) reported that

more than a third of men and 1 in 7 women were reconvicted over a mean follow up period of 6.2 years (range 1 month to 9.9 years). The PD diagnosis was the third most important prognostic risk factor for time to reconviction after male gender and past conviction for a similar offence. PD diagnosis yielded a hazard rate of 2.4%. In contrast, the rate for delusional disorder, for example, was 1.1%. Epidemiological studies also showed high prevalence of PD among homicide perpetrators. For instance, in a cross sectional survey of homicide perpetrators in Finland, Eronen, Hakola & Tiihonen (1996) reported that, compared to those without any mental disorder, males with a PD were almost 35 times more likely to commit homicide, whereas males with schizophrenia were 8 times more likely to commit homicide.

Epidemiological evidence cited above suggests a relationship between PDs, particularly APD, and violence (Coid et al., 2006a). Further, by requiring a "functional link" between severe PD and risk of serious harm to others, a causal relationship was implied by the criteria for admission to the DSPD pilot units established in U.K. for assessing and treating such patients (Department of Health and Home Office, 1999; also see section K of this chapter). However, it is important here to differentiate between risk factors and causal factors. A risk factor is one that consistently predicts the outcome of interest. In contrast with this, necessary conditions for inferring causality require (i) covariance between the predictor and outcome; (ii) temporal precedence (i.e. the predictor preceding outcome); (iii) exclusion of alternative explanations; and (iv) a logical connection between the variables under study (Haynes, 1992).

In reviewing the criteria required for a causal relationship between PD and violence, Duggan & Howard (2009) could find no unequivocal evidence to support such a relationship. They suggested that third variables may mediate the relationship, and pointed to the importance of considering co-morbid disorders, both within and across Axes I and II of the DSM-IV (American Psychiatric Association, 1994). They also emphasized the necessity of specifying an understandable mechanism through which the disorder might cause violence (see also: Logan & Johnstone, 2010).

However, a major impediment to research in this area is the problems associated with the assessment and diagnosis of PDs. Measures of personality disorder are notoriously unstable, and diagnosis may vary from one assessment method to another (Duggan & Gibbon, 2008). Clinical diagnosis is a categorical measure, whereas personality traits are continuous variables. Another impediment to research in this field is the issue of circularity of definition. This arises because the diagnostic criteria for some PDs (especially Cluster B disorders) include features that are likely to be associated with criminality, for example aggression, anger dyscontrol, hostility, irresponsibility, impulsivity and callousness. The relationship between PD and violence is further clouded by the issue of co-morbidity, since patients presenting with PD typically present with more than one PD (Zimmerman, Rothschild & Chelminski, 2005), and PDs are strongly co-morbid with DSM Axis I disorders (Fossati, Maffei, Bagnato, Battaglia, Donati, Donini et al., 2000; Zimmerman & Coryell, 1990). Within the Cluster B PDs, APD and BPD show an especially strong co-occurrence in clinical, and particularly forensic, samples (Fossati et al., 2000; Becker, Grilo, Edell, & McGlashan, 2000; Coid, Moran, Bebbington, Brugha, Jenkins, Farrell et

al., 2009). This selective co-occurrence of APD and BPD likely reflects genetic and environmental influences common to these disorders (Torgerson, Czajkowski, Jacobso, Reichborn-Kjennerud, Røysamb, Neale et al., 2008).

As well as co-morbidity between APD and BPD, the co-occurrence (or overlap) of APD with psychopathy, operationalised by the Psychopathy Checklist-Revised (Hare, 2003) needs to be considered, since this co-morbidity has been found to associate with increased violence in the criminal history of offenders compared with APD alone (Hare, Hart & Harpur, 1991; Coid & Ullrich, 2010; Kosson, Lorenz & Newman, 2006).

C. Psychopathy

Modern conceptualisations of psychopathy, a constellation of interpersonal, affective and behavioural factors, draw heavily from Cleckley's (1941) account of psychopathy (Patrick, Fowles and Krueger, 2009). Cleckley defined 16 diagnostic criteria for psychopathy which have been clustered into three groups by Patrick (2006) as follows: (i) "positive adjustment indicators" such as lack of anxiety, absence of delusions, normal intelligence, and low suicide rates; (ii) "behavioural deviance indicators" including recklessness, irresponsibility, inability to learn from punishment, and lack of clear future plans; (iii) "indicators of emotional unresponsiveness and impaired social relatedness" which included such features as lack of guilt, impoverished emotions, inability to form lasting emotional ties, egocentricity, callous use of others, and superficial charm.

Guided by Cleckley's conceptualisation of psychopathy, a number of diagnostic tools have been developed to tap into the construct of

psychopathy in different populations (e.g. see Patrick et al, 2009). Of relevance to this study is the Psychopathy Checklist (Hare 1991; 2003) which has been validated for use in criminal populations. The Psychopathy Checklist - Revised (PCL-R), which predominately incorporates in its conceptualisation of psychopathy personality dimensions of meanness and antisocial deviance factors (i.e. disinhibition), consists of 20 items which are rated from interview, official records, and collateral information obtained from other sources. A cut-off score of 30 is used to determine psychopathy, although a cut-off score of 25 or more is recommended for European samples (Cook, 1995). Factor analytic studies of PCL-R identified distinct factor analytic models, of which the best known model is the two factor model: Factor 1 - affective and interpersonal which reflects such characteristics as grandiosity, selfishness, and callousness; and Factor 2 - which reflects an antisocial, irresponsible, and parasitic lifestyle (Hare, Harpur, Hakstian, Forth Hart & Newman, 1990). Three (Cook & Michie, 2001) and four (Hare & Neumann, 2006) factor models of psychopathy have also been proposed more recently.

Although psychopathy is not formally recognised as a personality disorder within major psychiatric classification systems, aspects of it are reflected in DSM-IV's antisocial and narcissistic personality disorders and ICD-10's dissocial personality disorder. Since psychopathy captures personality traits other than deviant antisocial behaviour, it is argued that psychopathy represents a more valid diagnostic category of personality disorder than APD. It is also argued that it predicts course more accurately than DSM categorised personality disorders (Hare, 1996). It is notable that under the new hybrid categorical/dimensional system for classifying PDs proposed for

DSM-V, one of the five proposed personality disorder types is labelled "antisocial/psychopathic": see Skodol (2011).

A high psychopathy score on the PCL-R is considered as a risk factor for violence; for example, Hare and Neumann (2009) suggest that there is compelling evidence for an association between PCL psychopathy and violence. When individuals defined as psychopaths on the Hare PCL-R are compared with those not so defined, the former begin their offending history earlier, their offending is more versatile, they are more likely to reoffend (Hare, Clark, Grann, & Thornton, 2000; Harris, Rice, & Cormier, 1991; Coid, Yang, Ullrich, Zhang, Roberts, Roberts, et al., 2007) and are about four times more likely to commit further violent offences (Hemphill, Hare, & Wong, 1998). In a follow up study of 278 offenders for two years after release from English prisons, Hare and colleagues (2000) reported that those who scored above the European cut-off for psychopathy (25 or more on PCL-R), had a reconviction rate of 82% for general offences and 38% for violent offences, with the rates for those with low PCL-R scorers being 40% and 3% respectively.

Further, it is evident from correlational studies of psychopathy that although both factors correlate positively with each other, they show distinctive correlates (Patrick, et al., 2009). For instance, PCL-R factor 1 correlates positively with measures of selfishness, narcissism and use of instrumental aggression, but negatively with measures of fear and depression (Patrick et al, 2009). In contrast, PCL factor 2 correlates positively with measures of aggression, violent offending and impulsivity (Harpur, Hare & Hakstian, 1989) as well as measures of CD, APD and substance misuse disorders (Hare, 2003). The Hemphill et al

(1998) meta-analytic study showed that although both factors correlated equally with violent recidivism, correlations between Factor 2 and general recidivism were stronger than those for Factor 1. However, more recent studies suggest that only the social deviance factor (Factor 2) is strongly linked to violence (Walters, 2003; Leistico, Salekin, DeCoster & Rogers, 2008). For instance, Coid and colleagues (2007) in their follow up study of 1396 male offenders released from English prisons reported that only features of impulsiveness and antisocial lifestyle components of PCL-R factor 2 showed independent predictive power in relation to violent recidivism. Supporting these, a recent methodologically rigorous meta-analysis showed that, in males, only the second PCL factor predicted violence to a limited degree; the first PCL factor, representing core interpersonal and affective traits of psychopathy, failed to predict above chance level (Yang, Wong & Coid, 2010). Furthermore, the core PCL-R interpersonal and affective features were found not to interact with the behavioural/lifestyle traits in the prediction of violence (Kennealy, Skeem, Walters & Camp, 2010).

But what factors account for the association between psychopathy and violence? Unfortunately, psychopathy, particularly the behavioural component, is associated with a history of alcohol, and illicit drug, abuse (most psychopaths have such a history) or other externalizing behaviours such as impulsiveness. Therefore, it is entirely possible that the association between psychopathy and criminality is secondary to its association with substance misuse and impulsiveness.

However, the definition and assessment of psychopathy has remained controversial (Cooke, Michie, & Skeem, 2007). On the one hand, it is

valued by its advocates as a well-validated construct that identifies a particular group of offenders who are at substantially elevated risk of criminal and antisocial behaviour (Hare, 1996; 2003). On the other hand, its critics raise serious concerns about its validity as a construct. For instance, Blackburn (1988) argues that psychopathy represents a “medicalisation” of offending behaviour. And that defining individuals as psychopaths may cause them to remain in hospital or prison longer than necessary on grounds of risk or treatability, although existing evidence doesn’t support the commonly held belief that treatment response is inversely related to high psychopathy scores (D’Silva, K., Duggan, C., McCarthy, 2004). Further, since the PCL-R captures items relating to criminality (such as criminal versatility, juvenile delinquency and revocation of conditional release), it is unsurprising that it strongly predicts criminality and violent recidivism (McMurran, Khalifa & Gibbon, 2009). Skeem and Cooke (2010) argued that criminality is a consequence rather than a core component of psychopathy. They also argued that the core features of psychopathy that explain violent criminality may be an arrogant and deceitful interpersonal style, deficient affective experience, and an impulsive and irresponsible behavioural style.

Furthermore, Patrick and colleagues (2009) argued that while the PCL-R captures features of meanness and disinhibition (predominantly factors 1 and 2 respectively), it fails to adequately capture the positive adjustment indicators highlighted by Cleckley (see above). The authors presented a triarchic model of psychopathy and argued that psychopathy encompasses three distinct phenotypic constructs (namely disinhibition, boldness and meanness) which may have different aetiological pathways. According to this model, disinhibition reflects

poor impulse control. Boldness is construed in terms of social dominance, emotional resiliency, and venturesomeness. Meanness refers to a "*constellation of phenotypic attributes including deficient empathy, disdain for and lack of close attachments with others, rebelliousness, excitement seeking, exploitativeness, and empowerment through cruelty*" (Patrick et al, 2009; p. 927).

D. Externalizing

Another construct that is potentially related to PD and violence is externalizing. Using factor analytical and behavioural genetic techniques in a twin sample, Kreuger, Hicks, Patrick, Carlson, Iacono & McGue (2002) analysed DSM-III R symptoms of childhood CD, adolescent antisocial personality traits, and alcohol, nicotine and drug dependence together with a measure of impulsivity (lack of constraint). They demonstrated that these disorders had in common a predominantly heritable vulnerability (called externalizing) contributing to the development of diverse traits and problem behaviours, whose precise phenotypic expression, e.g. antisocial deviance of various sorts, is determined by other, more specific aetiological influences (Krueger et al, 2002; Patrick & Bernat, 2010). Externalizing is related to disinhibition, a general phenotypic propensity towards impulse control problems entailing a lack of planfulness and foresight, impaired regulation of affect and urges, insistence on immediate gratification, and deficient behavioural restraint (Patrick et al, 2009). As implied by this definition, disinhibition is in turn related to emotional impulsiveness: the experience of, and failure to control, strong emotional impulses (Schapiro, 1965).

While the link between 'externalizing' and violence in adulthood is yet to be appraised further, evidence reviewed below indicates that a range of "externalizing-specific behaviours" (Eaton, South & Krueger, 2010), including CD, substance use, and impulsiveness have been linked to antisocial behaviour including violence.

E. Conduct Disorder

Conduct disorder (CD) is a repetitive and persistent pattern of behaviour which entails the violation of social norms and the right of others (American Psychiatric Association, 1994). It represents an important clinical problem in children for a number of reasons. First, CD is among the most commonly encountered psychiatric disorders in clinical practice (Loeber, Burke, Lahey, Winters & Zera, 2000), with prevalence rates of 1.7% for boys and 0.6% for girls being reported in 5 to 10 years old children (Meltzer, Gatwood, Goodman & Ford, 2000). Second, it is a major public health concern and puts a huge financial burden on society in terms of health and social care expenditure (Eme, 2009). Third, in addition to inflicting harm on others, CD has been associated with a poor prognosis as indexed by increased risks, in its sufferers, of criminality and a range of other psychiatric disorders including substance misuse, depression and PD particularly APD (Lahey, Loeber, Burke & Applegate, 2005).

CD is classified in the DSM-IV (American Psychiatric Association, 1994) under the umbrella of Disruptive Behavior Disorders (DBD) along with a number of overlapping (in terms of poor behavioural control) and yet different disorders including attention deficit hyperactivity disorder (ADHD) and oppositional defiant disorder (ODD). Loeber et al (2000) argue that there are several developmental sequences that link ADHD,

ODD, CD, and antisocial PD (APD). Loeber & Burke (2011) argue that while these disorders differ from each other in terms of their diagnostic features, implied in the DSM-IV is the supposed developmental sequence from ODD to CD. The authors also argue that this implied developmental sequence is further reinforced by the way the diagnostic criteria for these disorders are structured. For instance, the diagnosis of APD requires evidence of three or more CD symptoms before age 15.

Irrespective of the restrictions imposed within the DSM-IV, there is evidence to support the developmental sequence from ODD to CD. When these disorders co-occur with ADHD in the same individual the onset of ADHD is earlier than ODD (Nock, Kazdin, Hiripi, & Kessler, 2007). However, a sizable proportion of children with ADHD will not go on to develop ODD and, conversely, many children with ODD do not have a history ADHD. Further, a large proportion of conduct disordered children do not have a history of preceding ODD suggesting that this supposed developmental pathway is applicable only to a portion of CD cases (Loeber & Burke, 2011).

While much research attests to the continuity of disordered conduct from childhood into young adulthood and beyond, (e.g. Robins, 1966; 1978; Moffitt, Caspi, Harrington & Milne, 2002), the relationship between childhood CD and APD remains problematic for at least three reasons. First, CD appears to predispose to the development of a wide range of adult disorders (Kjelsberg, 2006) and to the entire spectrum of PDs rather than just APD (Bernstein, Cohen, Skodol, Bezirgianian & Brook, 1996; Blackburn, 2007). Consistent with this, Howard, Huband & Duggan (2011) recently reported an association between PD co-morbidity and CD severity. In comparison with PD patients who met

only the adult criteria for APD, patients in whom adult antisociality co-occurred with borderline personality disorder (BPD) showed more PD co-morbidity and greater severity of CD. Second, although the rate of progression from childhood CD to APD has been estimated as “around 50%” (Kendall, Pilling, Tyrer, Duggan, Burbeck, Meader et al., 2009, p.293), variable rates of progression have been reported ranging from 30% (Robins, 1978; Burke, Waldman, & Lahey, 2010) to as high as 61% in adolescents with concurrent substance abuse problems (Myers, Stewart & Brown, 1998). Third, it remains unclear to what extent the presence of childhood CD makes a clinically meaningful difference to adult antisocial personality. Several past studies (e.g. Black & Braun, 1998) suggested that persons meeting the adult criteria for APD without CD suffer essentially the same disorder as those meeting full APD criteria (including CD) although they are less severely affected. For instance, in the Black & Braun (1998) study they were less likely to drink alcohol and to have conned others. However, this is questioned by results of a recent study that highlighted the role played by childhood CD in serious adult antisociality and suggested the existence of a clinically meaningful distinction between antisocial adults with and without antecedent childhood CD (Walters & Knight, 2010). These authors pertinently remarked: “*What we now need is research on the transition from conduct disorder to antisocial personality in order to clarify the nature of this relationship*” (p. 267). While factors in addition to childhood CD are clearly at play in determining a shift in the developmental trajectory towards antisocial personality disorder, precisely what these factors are remains unclear.

A possible answer to the question of what factors other than, or in addition to, CD point the developmental trajectory towards adult

antisocial behaviour was given by Howard (2006; see also chapter two). A developmental cascade hypothesis was proposed in which CD initially leads to a progressive and accelerating use of alcohol and other drugs in adolescence. Exposure of the vulnerable adolescent brain to excessive amounts of alcohol and other substances putatively results in structural and functional changes in the brain, particularly in those prefrontal areas involved in decision making and impulse control; namely vm-PFC. A vicious cycle then develops whereby increasing use of alcohol in adolescence results in increasing disinhibition and progressive misuse of alcohol. As a consequence, on entering adulthood such individuals suffer deficits in decision making that place them at high risk of serious antisocial conduct. Since this hypothesis was first proposed, evidence (reviewed below) has accrued supporting two central aspects of the hypothesis: first, that adolescent alcohol abuse results in structural changes in the brain; and second, that early-onset of alcohol abuse is a risk factor for both antisocial behaviour and heavy alcohol use in young adulthood.

F. Early Onset Alcohol Abuse

A history of substance abuse, and of alcohol abuse in particular, is common among forensic patients detained in high (Lumsden, Hadfield, Littler & Howard, 2005) and medium levels of security, especially among those with a diagnosis of PD (Coid, Kahtan, Gault & Jarman, 1999) and among patients with a history of violence referred for pre-trial psychiatric assessment (Soderstrom, Sjodin, Carlstedt & Forsman, 2004). In the Soderstrom et al. (2004) study CD was reported to be both highly co-morbid with substance abuse and highly prevalent among mentally disordered offenders. Both CD and substance abuse were significantly associated with violent recidivism. In a subsequent

analysis of the Swedish sample studied by Soderstrom et al. (2004), Gustavson, Sjodin, Forsman, Nilsson & Anckarsarsater (2007) reported a significant association between younger age of onset of substance (including alcohol) abuse and a range of variables associated with externalising, including violent recidivism, PCL psychopathy, CD, lifetime aggression, and both antisocial and borderline PD. The association of APD with early-onset substance abuse reported by Gustavson et al (2007) confirms previous findings (Bakken, Landheim & Vaglum, 2004).

Studies of brain structure in adolescent alcohol abusers in comparison with non-abusers suggest the former show significant changes (De Bellis, Van Voorhees, Hooper, Gibler, Nelson, Hege et al., 2008), particularly in frontal cortex (De Bellis, Narasimhan, Thatcher Kashavan, M. S., Soloff, P & Clark, 2005). Even in the absence of alcohol abuse, adolescent binge drinking has been reported to be associated with widespread structural brain changes (McQueeney, Schweinsburg, Schweinsburg, Jacobus, Bava, Frank et al., 2009).

Adolescent onset alcohol abuse/dependence has emerged from recent longitudinal studies as a significant risk factor for life-course persistent (LCP) antisocial behaviour (Farrington, Ttofi & Coid, 2009) and for both violence (Wells, Horwood & Fergusson, 2004) and heavy alcohol use (Buchmann, Schmid, Blomeyer, Becker, Treutlein, Zimmermann et al., 2009) in late adolescence and early adulthood. In the Wells et al. (2004) study, adolescence-onset alcohol abuse was found to predict violent offending both in late adolescence (age 15-21) and in early adulthood (age 21-25), even after controlling for confounding background and individual factors, including CD. In former adolescent

psychiatric patients followed up to age 40, co-morbid substance (including alcohol) abuse in adolescence was associated with later serious (including violent) and persistent antisocial behaviour (Kjelsberg, 2008). Consistent with these findings, other studies have reported that measures of early alcohol use such as age of first drink were associated with heightened risk of delinquency and criminal behaviour (Brems, Johnson, Neal and Freemon, 2004) and of disinhibitory psychopathology generally (Zernicke, Cantrell, Finn and Lucas, 2010). Early age of drinking onset has been reported to strongly predict heavy alcohol consumption in young adulthood, even after controlling for preceding externalizing symptoms which, however, were associated both with younger age of drinking onset and with more frequent and hazardous drinking in young adulthood (Buchmann et al., 2009).

Considered together, these results indicate that both CD and adolescent onset alcohol abuse are important risk factors for adult externalising psychopathology, and that adolescent alcohol abuse, in combination with CD and possibly through its associated brain pathology, may account for a significant proportion of the variance in adult antisocial behaviour.

However, the aforementioned co-morbidity of CD with substance abuse makes it difficult to tease apart their separate and conjoint influence on adult antisocial behaviour. DeBrito & Hodgins (2009) go as far as to assert that "*...almost all children and adolescents with CD will abuse alcohol and/or drugs...*" (p. 139). Notwithstanding this, in a study of 477 young adults at high risk for drug and alcohol use, it proved possible to identify a group of individuals who met DSM-IV diagnostic

criteria for CD but not for alcohol dependence (Finn, Rickert, Miller et al., 2009). While this CD-alone group were similar to a group having CD combined with alcohol dependence in terms of the age at which their alcohol abuse commenced, the latter (co-morbid) group showed a higher level of lifetime externalising problems, including drug, alcohol and adult antisocial problems. However, the effect of alcohol dependence was confounded by CD, since severity of CD was greater in the group with both CD and alcohol dependence; moreover, some of the CD group had a history of alcohol abuse but not dependence. Nonetheless, these results implied that alcohol abuse may have either moderated (i.e. exacerbated) or mediated the relationship between CD and adult antisociality.

To verify this, a further study was undertaken by Howard, Finn, Gallagher and Jose (in press) to examine the possible mediating and/or moderating role of EOAA using the Finn et al. (2009) sample (with alcohol abuse excluded from the CD-only group), using regression analysis to control for co-varying CD and EOAA. Results of this study showed that both EOAA and CD had significant and independent effects on adult antisociality, but that EOAA both significantly mediated and exacerbated the effect of CD (Howard, Finn, Gallagher & Jose, in press).

G. Impulsiveness

Impulsiveness is a personality construct that has been included in the diagnostic criteria of various forms of psychopathology including DSM-IV Cluster B personality disorders, CD and substance misuse disorders (Komarovskaya, Booker Loper & Warren, 2007). Impulsiveness has two major dimensions, cognitive and behavioural, although some

commentators (e.g. Whiteside and Lynam, 2001) argue that it has four facets; namely Urgency, Premeditation (lack of), Perseverance (lack of), and Sensation Seeking. Urgency refers to acting under conditions of negative affect and without giving due consideration to the consequences of one's behaviour. Premeditation (lack of) concerns the tendency to stop and think about the consequences of an act before engaging in the act. Perseverance (lack of) refers to the ability to remain focussed on a task despite it being boring. Sensation Seeking concerns excitement seeking and risk taking behaviour. These facets are tapped by different subscales in the UPPS Impulsiveness Scale, a self-report questionnaire used in this study to measure impulsiveness (Whiteside & Lynam, 2001). More recently, a fifth facet has been added; namely positive urgency which entails acting rashly while in a positive mood state (Cyders, Smith, Spillane, Fischer, & Annus, 2007).

Impulsiveness has genetic and biological underpinnings, with a number of brain structures being implicated in impulse control including the ventro-medial prefrontal cortex (vm-PFC), dorso-lateral prefrontal cortex (DL-PFC), anterior cingulate cortex (ACC) and others (Völlm, Richradson, McKie, Elliott, Deakin, & Anderson, 2006). The vm-PFC, in particular, is thought to be implicated in impulse control as well as in processing of social cues, and decision making especially under conditions of uncertainty (i.e. choosing between options with uncertain outcomes) including risky or ambiguous decisions (Bechara, 2007). Impulsiveness can be assessed using self report measures such as the UPPS Impulsive Behaviour Scale (Whiteside & Lynam, 2001), and behavioural measures such as the Iowa Gambling Task (Bechara, Damasio, Damasio & Anderson, 1994; Bechara, 2007).

Reviews of the empirical studies of impulsiveness show that impulsiveness, (variously defined as low self-control, inattention, hyperactivity, sensation seeking, acting out without thinking of consequences, and being short sighted, insensitive or risk taking) is a strong predictor of offending behaviour (Pratt & Cullen, 2000; Pratt, Cullen, Blevins, Daigle & Unnever, 2002), including violence as judged by self report or official records (Jolliffe & Farrington, 2009). Several studies showed a link between impulsiveness and antisocial behaviour in children and adolescents. For instance, in the Pittsburgh Youth Study, teacher rated impulsivity strongly correlated with delinquency at age 10 and 13 (White, Moffitt, Caspi, Bartusch, Needles & Stouthamer-Loeber, 1994). These authors found out that it was the behavioural element of impulsivity and not the cognitive element that best predicted antisocial behaviour. Further, ADHD features (such as poor attention, hyperactivity, and restlessness) at age 11-13 predicted arrests for violence up to age 22 in a study by Brennan, Mednick & Mednick (1993).

The link between alcohol misuse and impulsiveness is well documented (Jolliffe & Farrington, 2009), although the nature of this link is not fully understood (Dolan, Bechara & Nathan, 2008). There is evidence that measures of neuropsychological dysfunction correlate positively with impulsiveness in individuals with substance use disorder (e.g., Gillen & Hessebrock, 1992) and that the link between genetic predisposition for substance misuse is mediated via impulsiveness (Finn, Sharkansky, Brandt, & Turcotte, 2000).

H. Do Individuals With APD Show Frontal Lobe Dysfunction?

Review of neurobiological studies of antisocial populations is fraught with difficulties, in particular in relation to the use of different measures to determine caseness (e.g. by offending history, diagnostic categories, history of adversity...etc) and the use of different antisocial outcomes (e.g. delinquency, antisocial behaviour, aggression...etc), presenting reviewers in this field with major challenges (for a comprehensive review see Patrick & Verona, 2007). It is worth noting that although there is a considerable overlap between APD and psychopathy in terms of poor behavioural control, some commentators (e.g. Patrick & Verona, 2007) argue that findings of studies that examined brain differences in psychopathic individuals should be considered separately. This is because, in addition to impulsive-antisocial features, psychopathy (as defined by the PCL-R) incorporates affective-interpersonal features that have distinct correlates (Patrick & Verona, 2007). Therefore, in this section I will focus on findings relevant to APD. For findings relevant to psychopathy see review by Raine & Yang (2006).

Studies of patients with defined neurological lesions have provided insights into which brain structures, when damaged, may predispose to antisocial behavior in some individuals. The most frequently cited case in the literature is the classic case of Phineas Gage, a man of blameless character who developed antisocial tendencies after he sustained an injury to the frontal part of the brain (for more details see Damasio, Grabowski, Frank, Galaburda, Damasio, 1994). Existing literature suggests that head injury, whether acquired during childhood or adult life, is highly prevalent among offender populations (Blake, Pincus & Buckner, 1995). There is also evidence that brain injury at an early age, particularly to the prefrontal and temporal parts of the brain, increases the risk of subsequent development of antisocial tendencies

(Schug, Gao, Glenn, Peskin, Yang & Raine, 2010). Anderson, Bechara, Damasio, Tranel and Damasio (1999) reported on the long term sequelae of early ventro-medial prefrontal cortex damage occurring before 16 months of age in two adults who displayed features similar to that of adult psychopathy. Similar to adult onset brain damage, they showed evidence of impaired social control and decision making and insensitivity to punishment in the presence of intact cognitive abilities. However, unlike adult onset patients they also showed evidence of defective social and moral reasoning.

Neuroimaging studies of antisocial populations confirm the finding of poor prefrontal functioning (e.g. Goyer, Andreason, Semple, Clayton, King, Compton-Totm et al., 1994; Volkow, Tancredi, Grant, Gillespie, Valentine, Mullani, et al., 1995; Amen, Stubblefield, Carmicheal, Thisted, 1996; Kuruoglu, Arikan, Vural, Karatas, Arac, Isik, 1996). Dolan, Deakin, Roberts and Anderson (2002) compared a group of incarcerated "impulsive-aggressive" male PD patients with healthy control subjects on measures of executive (putative frontal lobe) functioning and evidence of temporal and frontal lobe changes on MRI. The authors reported that, compared to control subjects, PD patients showed 20% reduction in temporal lobe volumes; they showed no evidence of reductions in frontal lobe volume, despite evidence of impairments in executive function. However, the patient group showed a reduction in prefrontal brain areas when individual regions were examined, indicating that prefrontal areas may be reduced in impulsive-aggressive subjects. Although the authors indicated that the effects of substance misuse were kept to minimum because the PD subjects were incarcerated, the study failed to control for lifetime history of substance misuse, particularly early onset alcohol abuse. It is notable that the co-

morbidity was common in the sample, with the majority of PD subjects meeting the DSM-III-R diagnostic criteria for other Cluster B PDs especially BPD.

It is worth noting that the vast majority of these studies failed to control for co-morbidity of Axis I and Axes II disorders particularly co-morbid substance misuse and all have been conducted on relatively small and selected samples derived from hospital or prison settings. A notable exception is a study by Raine Buchsbaum, Lencz, Bihrlé, LaCasse, Colletti (2000) which reported MRI findings in four groups; a group with diagnosis of APD, a healthy control group, a substance dependent group who had a lifetime diagnosis of drug or alcohol dependence but not APD. Since the APD group had co-morbid psychiatric disorders other than substance misuse, they were matched to a control psychiatric group to assess whether the brain changes were artefacts of psychiatric co-morbidity. The results showed evidence of 11% reductions in orbito-frontal (OFC) volumes in the APD group as compared with the other groups. Although the study did not specify which sub-region of the prefrontal cortex was particularly reduced in volume, the authors predicted that impairment was likely to be confined to the orbito-frontal region. However, the study suffered a number of limitations which the authors candidly acknowledged. These included inability to generalise the results to women with APD since only men were included and failure to assess brain regions other than the prefrontal cortex.

Studies of neuropsychology of personality disorders provide additional insights into which brain functions, when impaired, may predispose to antisocial tendencies in some individuals. The neuropsychology of PD is

a relatively under-researched area. Early reviews of studies of violent offenders with APD revealed deficits in a broad range of executive and memory functions compared with healthy controls (e.g. see Moffitt & Henry, 1989; Dolan, 1994; Morgan & Lilienfeld, 2000).

A more recent review of relevant literature up to 2002 concluded that research in this area focussed predominately on psychopathy, APD and BPD (Dolan (2003). The author commented that "*Although there is evidence that antisocial and borderline personality disorders have deficits in executive and memory functions, relatively little is known about the neuropsychology of other clusters of personality disorders*" (p. 25). Further, Dolan commented that the presence of confounding factors made it difficult for researchers in this area to draw valid conclusions about the extent of neuropsychological deficits in individuals with personality disorder. Co-morbid substance abuse, particularly alcohol abuse, is an obvious confounding factor since it is highly prevalent in incarcerated mentally disordered offenders (Quayle, Clark, Renwick, Hodge & Spencer, 1998). A large proportion of such individuals have a history of early onset (before age 19) alcohol abuse (Lumsden et al, 2005).

To overcome the confounding effects of alcohol and illicit drugs abuse, Dolan and Park (2002) examined dorso-lateral PFC and ventro-medial PFC functions in patients with APD who had no history of substance misuse and control subjects using the Cambridge Neuropsychological Test Automated Battery (CANTAB) and a Go/NoGo task respectively. The results showed evidence of impairments of both DLPFC and VMPFC function in APD subjects. However, major impediment to research in this area is the problems associated with the assessment and diagnosis

of personality disorders. Measures of personality disorder are notoriously unstable, and diagnosis may vary from one assessment method to another (Tyrer & Garralda, 2005; Duggan & Gibbon, 2008).

Evidence reviewed above indicates that psychopathy, CD, EOAA, frontal lobe dysfunction and impulsiveness are important risk factor for violence in people with PD. However, the literature on, and consequently our understanding of, risk factors for antisocial behaviour has developed rapidly in the last few decades (Raine, 2002), indicating that a host of other risk factors may also influence the link between PD and violence. As Farrington (2010) pointed out *"fortunately or unfortunately, literally thousands of variables differentiate significantly between official offenders and non-offenders and correlate significantly with reports of offending behaviour by young people"* (p113). A brief overview of the most important risk factors is presented in the next section. These are categorised into two broad categories; psychosocial factors and biological factors. A brief outline of the main factors that protect against antisocial behaviour is also presented.

I. Development of Antisocial Behaviour From Childhood

The major psychosocial risk factors for antisocial behaviour in children and adolescents include difficult temperament (Eme, 2009; Caspi, 2000; Schwartz, Snidman & Kagan, 1996), callous unemotional traits (Frick & Dickens, 2006; Frick, Cornell, Bodin, Dane, Barry & Loney, 2003) and features of impulsivity (Farrington, 2010; White, Moffitt, Caspi, Bartusch, Needles & Stouthamer-Loeber, 1994) and ADHD (Brennan, Mednick & Mednick, 1993; Thapar, van den Bree, Fowler, Langley & Whittinger, 2006). Other risk factors may be related to poor parenting (Smith & Stern, 1997; Robins, West & Herjanic, 1975;

Haapasola & Pokela, 1999; McCord, 1979; Farrington, 1995), and child victimisation (e.g. through neglect and physical or sexual abuse; Beach, Brody, Gunter, Packer, Wernett & Philibert (2010; Morash & Rucker, 1989).

The major biological risk factors include genetic influences (e.g. Caspi, McClay, Moffitt, Mill, Martin, Taylor, & Poulton, 2002; Caspi, Langley, Milne, Moffitt, O'Donovan, Owen et al, 2008; Burt & Mikolajewski, 2008); peri-natal factors such as fetal exposure to toxins (Fast, Conry & Loock, 1999), birth complications (Raine, Brennan & Mednick, 1994) and minor physical abnormalities (Raine, 2002); and acquired brain injury at an early age (Blake, Pincus & Buckner, 1995), particularly to the prefrontal and temporal parts of the brain (Schug, Gao, Glenn, Peskin, Yang & Raine, 2010). They also include low IQ (Schug et al, 2010), verbal deficits (Moffitt, Lynam, & Silva, 1994) and impairment of executive functioning (Moffitt, 1993).

Consistent findings in the psychophysiology literature include low resting autonomic activity (indexed by low heart rate and skin conductivity; Raine, 2002), impaired parasympathetic versus sympathetic mediation of heart rate reactivity and enhanced autonomic reactivity to stressors, although the literature in this area yielded mixed results with some studies showing an increased reactivity and others decreased reactivity to stressors (for a comprehensive review see Patrick & Verona, 2007). Psycho-physiological studies show evidence of electrocortical abnormalities in antisocial children (Raine, Venables and Williams, 1990; Raine, Venables & Williams, 1995; Brennan, Raine, Schulsinger, Kirkegaard-Sorensen, Knop, Hutchings et al., 1997). The most consistent finding in ERP studies of children has been reduced

P300 amplitude in those with conduct disorder (Bauer & Hesselbrock, 1999), ADHD (Johnstone & Barry, 1996) and other externalizing disorders (Patrick, 2008).

Brain imaging studies of children with antisocial tendencies reveal temporal lobes volume reductions in early-onset conduct disordered children (Kruesi, Casanova, Mannheim & Jonson-Bilder, 2004); reduced volume/ratio reductions in the corpus callosum in youth liars (Kruesi & Casanova, 2006); inverse correlation between severity of aggression and metabolism in the medial prefrontal and left temporal cortex in children with epilepsy (Juhasz, Behen, Muzik, Chugani & Chugani, 2001); reduced right hemisphere activation, particularly in the temporal lobes, in adult perpetrators of severe violence who were victims of abuse during childhood (Raine, Park, Lencz, Bihrlé, LaCasse, Widom, et al., 2001); and impairment in the dorsal anterior cingulate cortex in conduct disordered children (Sterzer, Stadler, Krebs, Kleinschmidt & Poustka 2005).

The most consistent finding in endocrine studies has been low resting cortisol levels (Poustka, Maras, Hohm, Fellingner Holtmann, Banaschewski et al., 2010) indexing low fear reactivity in antisocial children (Kagan, Reznick & Snidman, 1988). Recent studies implicated autoantibodies in aggressive behaviour (e.g. Fetissov, Hallman, Nilsson, Lefvert, Orelund, and Hökfelt, 2006).

Evidence is accumulating that malnutrition during infancy and deficiency in minerals and vitamins during early childhood increase the risk of aggression, conduct problems, attention deficits and externalizing problems in late childhood (Cunnane, 1988; Liu, Raine,

Venables & Mednick, 2004); Corrigan, Gray, Strathdee, Skinner, Van Rhijn, & Horrobin, 1994p; Liu & Raine, 2006). Environmental toxins such as lead have been linked to aggressive behaviour in children (Needleman, Riess, Tobin, Biesecker, & Greenhouse, 1996; Fergusson, Horwood & Lynskey, 1993).

The literature on the link between serotonin activity and aggressive behaviour is growing (Loney, Butler, Lima, Counts & Eckel, 2006). Consistent findings in this area are positive and inverse link between 5HT and aggression in children (Kruesi, Rapoport, Hamburger et al., 1990); higher plasma serotonin levels in boys with childhood onset - as opposed to adolescent onset - CD (Unis, Cook, Vincent et al, 1997); and positive association between prolactin response and aggression in boys at age 8 and 10 (Pine, Coplan, Wasserman, et al. 1997).

J. The "How" Question

Despite the vastness of the literature on risk factors, only a relatively small number of studies assessed the interplay between these factors in relation to antisocial behaviour. For instance, the review by Raine (2002) identified only 39 empirical studies that specifically addressed this interaction. Raine (2002) concluded that "*studies conducted to date are relatively simplistic, and the question whether these biosocial interactions are carried by conditions comorbid with antisocial behaviour such as hyperactivity need to be resolved*" (p323).

A major unanswered question is that of the mechanism through which PD, including PD co-morbidity, is linked to violence. It is important to recognise that although PD (with or without psychopathy) may be a risk factor for violence, it is not necessarily a causal factor. Causality

requires a logical mechanism linking PD with violence. Cleckley's (1941) classic description of the prototypical "psychopath" lacked any reference to serious, and in particular violent, antisociality, and there is no *a priori* reason why the core interpersonal (e.g. glibness and superficial charm) and affective (e.g. poverty of emotion) features of psychopathy should be causally linked to a propensity for violence. The same applies to antisocial/borderline co-morbidity whose association with impulsiveness and anger proneness suggested emotional dysregulation as a possible mechanism (Howard, Huband & Mannion, Duggan, 2008). It is doubtful, however, whether anger proneness is a key variable. A study of PD patients having adult antisociality with or without borderline PD co-morbidity found that those showing this co-morbidity self-reported very high anger, but so too did patients, predominantly female with a single BPD diagnosis who were *not* antisocial (Howard, Huband & Duggan, in press).

However, impulsiveness, particularly emotional impulsiveness and its neural substrates, remains a possible mechanism. Patrick and colleagues have suggested that deficits in self-regulation in high-externalising individuals arise from impairments in the functioning of higher brain systems that operate to guide and inhibit behaviour and regulate emotional responses (Patrick & Bernat, 2006; 2009). On the basis of results from brain event-related potential (ERP) studies, these authors proposed that high externalizing individuals suffer from a cognitive-associative processing deficit that disrupts anticipation, reflection and self-regulation of affect and behaviour. However, Patrick and colleagues do not link this deficit to specific antecedents. Indeed, while the externalising construct usefully links together diverse clinical phenomena, including CD, alcohol dependence, adult substance abuse

and adult antisocial behaviour, it falls short of specifying a plausible pathway through which these phenomena might be causally linked. Without specification of a causal pathway it is difficult, for example, to explain the wide variation - between 30% and 60% - reported in the literature for the rate of progression from CD to APD across different studies and samples (reviewed in Kjelsberg, 2006). It is notable that the sample in which a progression rate of 60% was reported comprised adolescents with concurrent substance abuse problems (Myers, Stewart & Brown, 1998).

Another current hypothesis (Howard, 2006; 2009) suggests that, in the context of disinhibitory psychopathology in childhood, early-onset abuse of alcohol and other substances disrupts the neural substrates of self-regulation during a critical, adolescent stage of brain development, resulting in spiralling use of alcohol and other substances. Consequently, on entry into adulthood, at around age 20, the brain (in particular those frontal regions involved in behavioural and emotional self-regulation) are functionally impaired and personality suffers maladaptive development. This maladaptive personality development would then place the individual at high risk of violent and antisocial behaviour. Since early-onset alcohol abuse has been linked developmentally to both APD and psychopathy (Bakken, Landheim, & Vaglum, 2004; Varlamov, Khalifa, Liddle, Duggan & Howard, 2011), it is reasonable to suppose that such maladaptive personality development would take the form of increased externalizing, e.g. increased impulsiveness and social deviance.

K. Forensic Mental Health Services

In England and Wales inpatient forensic mental health services are provided within the National Health Service (NHS) and the independent (private) sector. They are usually delivered at secure hospitals which are stratified, based on the level of security measures they provide, into three levels of security – high (only available within the NHS), medium and low. The level of risk posed by the patient determines the level of security that will be required to manage their risks. The main criterion for detention at high security (also referred to as special hospitals) is that the patient should present a "*grave and immediate danger to the public if at large*" (Department of Health, 2004). Admission to 'Dangerous and Severe Personality Disorder' (DSPD) services requires that additional criteria are met as described below.

In 1991 the UK Government first coined the term DSPD in a consultation paper (Department of Health & Home Office, 1999). In this document, proposals were made for the detention and treatment of a small proportion of severely personality disordered individuals who pose a significant risk of harm to others and themselves. The consultation paper was largely driven by long-term frustration within government departments with mental health services which largely excluded individuals with personality disorder from their provisions on the grounds of treatability (Maden, 2007). Following a period of consultation, the Home Office and the Department of Health jointly initiated a DSPD assessment and treatment programme in prisons and high security hospitals, which resulted in the development of more than three hundred high security placements over a three years period (Whitemoor prison 70, Frankland prison 86, Broadmoor hospital 70, and Rampton hospital 70). Classification as DSPD requires the conjunction of three elements: firstly, dangerousness defined as a high

risk of committing an offence within 5 years that might be expected to lead to serious physical or psychological harm from which the victim would find it difficult or impossible to recover; secondly, severe personality disorder (defined in terms of either the presence of sufficient psychopathic traits, or the presence of sufficient variety of personality disorders); and, thirdly and critically, a functional link between personality disorder and dangerousness (Home Office & Department of Health, 2001; see also Tyrer, Barrett, Byford, Cooper, Crawford, Cicchetti, et al., 2007).

In contrast, the criteria for admission to medium security are less stringent. They are designed for patients detained under the Mental Health Act 1983 who '...pose a serious danger to the public'. For instance, a national survey of clinicians involved in assessing patients for admission to medium secure units in England and Wales (Melzer, Tom, Brugha, Fryers, Gatward, Grounds et al., 2004) revealed that factors associated with being deemed suitable for admission to medium security were having features of acute schizophrenia, non-concordance with treatment, a history of sexually inappropriate behaviour, and a history of self-harm.

The population of high security hospitals in England and Wales has been previously well described in the literature. For instance, a study by Taylor, Leese, Williams, Butwell, Daly, and Larkin (1998) showed that the population of high security hospitals (including Rampton) was predominantly male, white, and aged between 20 and 50 years. Among the 1740 patients included in this study, psychosis (mainly schizophrenia) was the most common diagnosis (58%) followed next by personality disorder and learning disability (26% and 16%

respectively). History of co-morbid personality and substance misuse disorders was common among patients with psychosis. Substance misuse prior to admission was also common among those with a primary diagnosis of personality disorder. Serious violence against another person (including homicide) was the most common reason for admission to high secure hospitals, followed next by sexual offending and arson.

Further, a systematic review of studies relating to the British special hospitals (Badger, Nursten, Williams & Woodward, 1998) identified the average length of stay as eight years and that a large proportion of patients who required long-term treatment and care at lower levels of security were unable to progress because of a shortage of medium and low secure provision. However, the situation has changed dramatically over the last two decades which witnessed a huge contraction of high secure provision together with an expansion in medium and low security provision across England and Wales. For instance, Coid, et al., (1999) found that in 1999 there were 2000 medium secure beds in England and Wales. By 2005 there were 2800 medium secure beds and more than 1500 Psychiatric Intensive Care Unit (PICU) and low secure beds (The Sainsbury Centre for Mental Health, 2005). According to a more recent national survey in the UK, by 2006 there were 170 PICUs treating 1242 patients and 137 low secure units treating 1583 patients (Pereira, Dawson & Sarsam, 2006).

A descriptive study of the clinical and risk characteristics of the DSPD population (Kirkpatrick, Draycott, Freestobe, Cooper, Twiselton, Watson, et al., 2010) showed that of the 241 patients and prisoners assessed for admission to DSPD, the majority were white (93.5%) with

a mean age of about 35 (SD=8.7) years. The majority had history of violent and sexual offending (91.1% and 60.1% respectively) and a quarter of them were convicted of both a violent and sexual index offence. Personality disordered participants who met the DSPD criteria showed high mean scores on Psychopathy Checklist-Revised (Hare, 2003; 28.3, SD=4.8) and the PCL-R two factors: factor 1, selfish, callous & remorseless use of others (10.8, SD=3) and factor 2, chronically unstable & antisocial lifestyle (15.1, SD=3). Assessment of personality profiles using the International Personality Disorder Examination (Loranger, 1997) revealed that the dangerous and severely personality disordered individuals had, on average, 2.55 personality disorders with antisocial and borderline being the most commonly diagnosed personality disorders (79% and 54% respectively). Regarding risk assessment, more than half were deemed to be at high risk of future violent offending according to the HCR 20 risk assessment schedule (Douglas, Webster, Hart, Eaves, & Ogloff, 2001). Two thirds were classified as being 'very high risk' for future sexual offending on the Risk Matrix 2000S (Thornton, Mann, Webster, Blud, Travers, Friendship, et al., 2003).

Existing literature also contains reports describing the population of medium security. For example, a study by Lelliott, Audini, and Duffett (2001) showed that the population of medium secure care in inner London was mainly male, single and unemployed prior to admission. The mean age was 36 and more than half were Black. Most of the cohort had a primary diagnosis of psychosis, and 10% had a primary or secondary diagnosis of personality disorder. The majority were detained under part III (patients concerned in criminal proceedings or under sentence) of the Mental Health Act 1983. Over one third were

admitted from courts and prisons, 8% from high security hospitals, 15% from other medium secure units and the remainder from community and general psychiatric services. For over a quarter, the main reason for admission to medium secure care was not recorded. The remainder committed a range of offences including murder, manslaughter, sexual offences, arson, assault, and criminal damage. Regarding follow up data, Davies, Clarke, Hollin and Duggan (2007) reported on the long-term follow up of 550 patients discharged from Arnold Lodge Medium Secure Unit over a twenty year period. The results showed that 10% of the patients had died, of whom one third died by suicide, and the risk of death was six times greater than in the general population. Half were reconvicted and almost two-fifths were readmitted to secure care. The authors concluded that patients discharged from secure units are a highly vulnerable group requiring careful follow-up.

CHAPTER TWO

STUDY HYPOTHESIS

A. The Hypothesis

The overall aim of the study was to test the hypothesis that the link between PD and violence is mediated by early onset alcohol abuse. It is hypothesised that adolescents with a history of early disinhibitory psychopathology, such as CD, engage in a pattern of increased alcohol consumption from an early age which disrupts the neural substrates of self-regulation during a critical, adolescent stage of brain development. Consequently, on entry into adulthood, at around age 20, the brain (in particular those frontal regions involved in behavioural and emotional self-regulation such as the ventro-medial prefrontal cortex) is functionally impaired and personality suffers maladaptive development. This maladaptive personality development would then place the individual at high risk of violent and antisocial behaviour. Since early-onset alcohol abuse has been linked developmentally to both APD and psychopathy, it is hypothesised that such maladaptive personality development would take the form of increased externalizing, e.g. increased impulsiveness and social deviance (Howard, 2006; 2009; also see figure 2).

B. Significance of The Hypothesis

The significance of this hypothesis lies in its implications for the risk assessment, treatment and prevention of violence in offenders with personality disorder. From this standpoint, and if the hypothesis were to be proved, it would have a number of implications: (a) assessment of

early onset alcohol abuse should be incorporated into the assessment of risk of violence; (b) existing therapeutic interventions designed to treat offenders with PD may need to be modified such that the needs of individuals who have a history of early-onset alcohol abuse and consequent frontal lobe dysfunction are taken into consideration; and (c) measures to prevent serious antisocial behaviour should target individuals at risk for engaging in heavy alcohol consumption in adolescence, for example, those with a history of conduct disorder or ADHD.

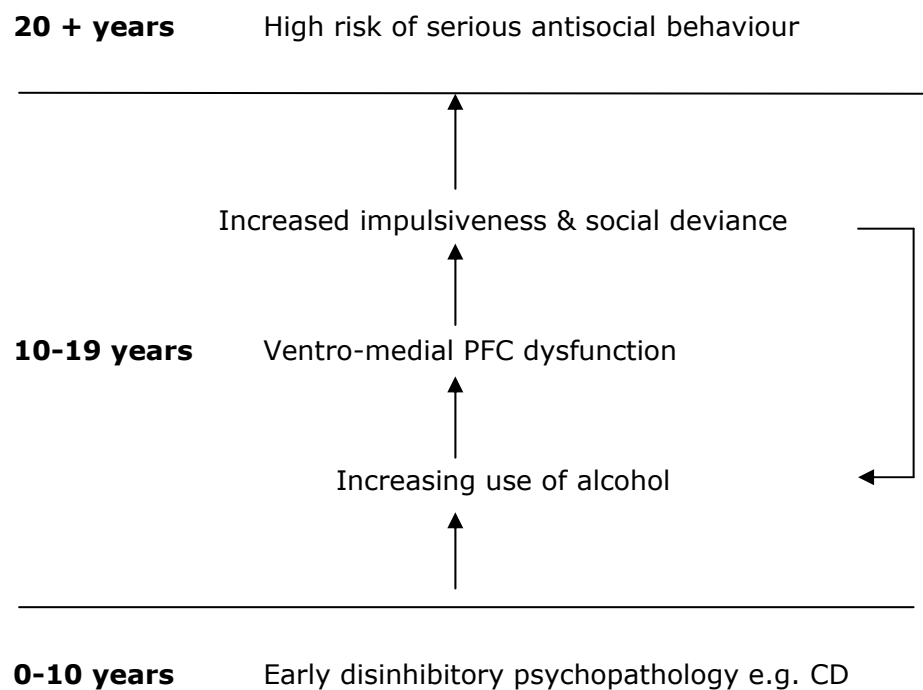

Figure 1: A schematic representation of the study hypothesis (after Howard, 2006). It is proposed that early disinhibitory psychopathology leads to increasing use of alcohol during adolescence causing impairment of ventro-medial prefrontal cortex functioning. This in turn will lead to increased impulsivity and impairment of goal directed behaviour placing the individual at a high risk of serious antisocial behaviour in adulthood.

C. Testing the Hypothesis

Three sets of testable predictions follow from the hypothesis:

1. First prediction: When offenders with personality disorder who have a history of EOAA are compared with those without such a history, the former would score higher on measures of childhood CD, vm-PFC dysfunction, impulsiveness, the social deviance factor of psychopathy (PCL Factor 2) and violent antisocial behaviour (violent antisociality).

2. Second Prediction: When the relationship between CD, early onset alcohol-abuse and violent antisociality is examined in offenders with PD, early onset alcohol-abuse will either moderate or mediate the link between CD and violent antisociality.

3. Third prediction: When the relationship between EOAA and violent antisociality is examined further, impulsiveness, vm-PFC dysfunction and PCL-R factor 2 will either moderate or mediate the link between EOAA and violent antisociality.

CHAPTER THREE

METHOD

A. The Sample

1. Study Participants

The participants of this study were 100 offenders with personality disorder detained at medium and high levels of security under the provisions of the English Mental Health Act 1983. They were recruited from the Dangerous and Severe Personality Disorder (DSPD) Units and Personality Disorder Services at Rampton (n=44) and Broadmoor (n=25) high security hospitals, and from the Personality Disorder Unit at Arnold Lodge Medium Secure Unit (n=31) in Leicester. All participants were detained under the Mental Health Act 1983 under the legal category of Psychopathic Disorder (the other categories were Mental Illness, Mental Impairment and Severe Mental Impairment). The term "Psychopathic Disorder" was an umbrella term used in the 1983 Act to encompass disorders of personality. It was defined as a *"persistent disorder or disability of mind (whether or not including significant impairment of intelligence) resulting in abnormally aggressive or seriously irresponsible conduct"*. However, in 2007 the amended Mental Health Act 1983 abandoned the legal categories of mental illness, psychopathic disorder, mental impairment and severe mental impairment and instead introduced a single category of mental disorder defined as *"any disorder or disability of the mind"*.

Within the English jurisdiction, in order for an individual to be liable to be detained under the revised 2007 Mental Health Act 1983, the following criteria must be met: (i) the individual must have, or be

suspected to have, a mental disorder; (ii) the mental disorder must be of a nature or degree to warrant detention in or to receive medical treatment in hospital; (iii) detention must be in the interests of the patient's health and safety or for the protection of others; and (iv) appropriate treatment must be available in hospital.

2. Inclusion and Exclusion Criteria

I aimed to sample as widely as possible among the personality disordered population in order to capture a broad sample, , both in terms of type and severity of personality disorder. At one extreme it was hoped to capture data from individuals who meet the criteria for a single personality disorder. At the other extreme it was intended to capture data from those who meet the criteria for DSPD. Since antisocial personality traits and behaviour are over-represented in men relative to women (Coid et al, 2006a), only men were recruited into the study. Those with an IQ score of less than 70 (on the basis of Weschler Adult Intelligence Scale; Weschler, 1997) were excluded. Since symptoms of psychosis would obfuscate differences between different types and severity of personality disorder, patients with identifiable major mental illness, i.e. Axis I diagnoses of psychosis or bipolar affective disorder on DSM-IV (American Psychiatric Association, 1994), were excluded as were patients with a history of head injury and epilepsy (see table 1 for more information).

A power calculation (2-sample comparison of proportions power calculation; the R Foundation for Statistical Computing, 2005) was computed on the assumption, based on previous research (e.g. Lumsden et al, 2005), that roughly 35% of patients would have had a history of early-onset alcohol abuse and 65% would have shown either

late-onset or no history of alcoholism. This indicated that a sample size of 43 per group (early onset v late onset and nil history combined) was required to give a power = 0.8 with a significance level set at $p = 0.05$. Therefore a total sample size of 86 personality disordered patients was targeted. To allow for attrition, 100 patients were recruited.

Inclusion criteria	Exclusion criteria
Male gender	Female gender
Age 18-65	History of major mental illness; psychosis, schizophrenia, or bipolar affective disorder
Diagnosis of at least one PD	History of head injury
Full scale IQ ≥ 70	History of epilepsy

Table 1: Inclusion and exclusion criteria

B. Procedure and Instruments

1. Perusal of Case-Files

Consenting patients were recruited into the study by inspection of their case files to make sure they met the inclusion criteria in terms of IQ and clinical diagnosis. Information concerning patients' clinical diagnoses (DSM-IV Axes I & II disorders) and Psychopathy (PCL) scores were recorded, including their scores on the 2 PCL-R factors: factor 1 and factor 2 (Hare, 2003). Information concerning their history of offending and current psychotropic medication (e.g. antipsychotics and antidepressants) was also recorded.

2. Assessment of Psychopathology and Violence

Eligible participants underwent the following assessments:

2.1 Assessment of Axis I Disorders

DSM-IV (American Psychiatric Association, 1994) Axis I disorders including childhood conduct disorder (CD), attention deficit hyperactivity disorder (ADHD), schizophrenia, bipolar affective disorder and alcohol abuse and dependence were assessed using the Computerized Diagnostic Interview Schedule for DSM-IV (C-DIS; Robins, Helzer, Cottler & Goldring, 1998). This is a computerised structured interview designed to ascertain the presence or absence of major psychiatric disorders as outlined in DSM-IV. In addition, it allows the researcher to collect socio-demographic information about ethnicity, marital status, level of education and number of years lived apart from biological parents before age 14. C-DIS has an adequate reliability and validity (for example see Horton, Compton & Cottler, 1998; Dascalu, Compton, Horton & Cottler, 2001).

2.2 Illicit Drug and Alcohol Use History

In addition to the use of C-DIS, assessment of illicit drugs and alcohol abuse history was supplemented with the use of a standardised drug and alcohol assessment protocol developed for use with mentally disordered offenders (Lumsden, Hadfield, Littler & Howard, 2005; see also appendix I). This included a series of questions regarding the participant's early experiences of alcohol (e.g. *How old were you when you first tasted alcohol? When did you start to drink alcohol regularly, say once or more a month? How old were you when you first got drunk?*). Information was obtained about how much patients drank in units of alcohol per week across their lifetime, starting from age 10. Detailed information was

obtained about lifetime use of the following classes of drugs: opiates, stimulants, cannabis, and hallucinogens. Life time use of each class was recorded as follows: (i) never=no history of illicit drug use; (ii) tried = used illicit drugs, but none excessive in the sense of (iii) or (iv); (iii) regular use = used illicit drugs once or more a week for at least six continuous months; and (iv) daily use = used illicit drugs once or more a day for at least 6 continuous months.

2.3 Assessment of Personality Disorder

Personality Disorder was assessed using the International Personality Disorder Examination (IPDE), interview version (Loranger, 1997; Loranger, Sartorius, Andreoli, Berger, Buchheim, Channabasavanna, et al., 1994). This 99 items semi-structured interview is designed to assess the ten DSM-IV Axis II personality disorders and personality disorder not otherwise specified. Individual IPDE items are scored on a three points scale (0=absent, 1=partially present, 2=definitely present) allowing dimensional scores to be derived for individual personality disorder categories as well as personality disorder clusters (cluster A, odd and eccentric; cluster B, dramatic; and cluster C, anxious avoidant).

It bears mention that in the case of Arnold Lodge participants, (n=31) a detailed breakdown of IPDE scores was available. These were administered by highly experienced clinicians as part of the pre- admission assessments. Where these data had already been collected as part of the clinical work-up, these were used in this study. In the remaining cases (n=69) I collected the data myself. However, for some of Arnold Lodge participants (n=13) I repeated

the IPDE and used Kappa statistic to measure inter-rater agreement. The highest Kappa value obtained was for Cluster C personality disorders (0.83, $p=0.002$), followed next by Cluster A (0.80, $p=0.005$) and Cluster B personality disorders (0.72, $p=0.003$). It is generally accepted by researchers that Kappa values of 0.61-0.80 represent substantial agreement and 0.81-0.99 almost perfect agreement between the raters (Viera & Garrett, 2005).

The severity of personality disorder was measured using the Tyrer & Johnson's scale (1996). This tool is designed to assess the severity of personality disorder on a 5-point severity scale: 0=no personality disorder; 1=personality difficulties (meets sub-threshold criteria for one or more personality disorders or has at least 10 traits, personality disorder not otherwise specified); 2=simple personality disorder (meets criteria for one or more personality disorders within the same cluster); 3=diffuse personality disorder (meets criteria for more than 1 personality disorder within more than one cluster excluding antisocial personality disorder); and 4=severe personality disorder (in addition to meeting the criteria for antisocial personality disorder, criteria for at least one other personality disorder in another cluster [A or C] are met).

2.4 Assessment of Psychopathy

Psychopathy was assessed using the Hare Psychopathy Checklist-Revised (Hare, 2003). The PCL-R guidelines were followed to rate each of the 20 PCL-R items; 0=definitely not present, 1=present to some extent or 2=definitely present. As well as obtaining a total score out of 40, scores on the 2 PCL-R factors (F1, selfish, callous & remorseless use of others; and F2, chronically unstable & antisocial

lifestyle) were obtained. PCL-R ratings were based on both interview and reading of case files and rated by trained and experienced clinicians.

2.5 Assessment of Violence

This was based on offending history and a Violence Severity Rating Scale (VSRS). Data concerning offending history was extracted from case files using a proforma designed for the purpose of this study (appendix III). This was supplemented with self report and Police National Computer (PNC) records. The Violence Severity Rating Scale - originally developed by Gunn and Robertson (1976) and later validated for use in hospitalised forensic patients by Wong, Lumsden, Fenton & Fenwick (1993) – was based on review of case files and incidents log. The scale has two subscales measuring the severity of the index offence and previous criminal record (see appendix IV). Each of the two subscales – Violence in Index Offence and Violence in Criminal Record – was rated on a 5-point scale (0 = minimal/no violence, 4 = severe violence, indicating someone's life or health was seriously endangered). An additional scale measuring violence in the institution was additional to the scales used by Wong et al. (1993) and was scored: 0 (no incidents of aggression), 1 (evidence of occasional intimidation, verbal aggression or minor property damage); 2 (verbal threats of serious violence or one or two incidents of physical aggression to others not causing significant injury); 3 (3 or more incidents of physical aggression resulting in non-serious injury); 4 (one or more severely violent episodes, or an incident involving use of a weapon against another person).

2.6 Assessment of Impulsiveness

This was assessed using the UPPS Impulsive Behaviour Scale (Whiteside & Lynam, 2001; also see appendix V) – a 45 items measure of impulsivity that has 4 subscales namely Premeditation (lack of), Urgency, Sensation seeking and Perseverance (lack of). Urgency, assesses an individual's tendency to give in to strong impulses, specifically when accompanied by negative emotions such as depression, anxiety, or anger. Urgency best approximates the construct of emotional impulsiveness (Schapiro, 1965) and is most closely related to psychopathy, particularly its social deviance aspect (Anestis, Anestis & Joiner, 2009). Perseverance (lack of) assesses an individual's ability to persist in completing jobs or obligations despite boredom and/or fatigue. Premeditation (lack of) assesses an individual's ability to think through the potential consequences of his or her behaviour before acting. Sensation Seeking measures an individual's preference for excitement and stimulation.

The respondent is required to rate each item on a scale of 1-4 (1= totally disagree, 4=totally agree). The subscales of premeditation and perseveration were reversely scored such that higher scores would indicate increased impulsivity (i.e. lack of premeditation or perseveration), giving a total UPPS score out of 180. Whiteside and Lynam (2001) present information on the internal consistency, as well as divergent and external validity of the UPPS.

2.7 Ventro-medial Pre-Frontal Cortex Dysfunction

This was assessed using the Iowa Gambling Task (IGT; Bechara, 2007). This is a computerised gambling test that assesses decision-making under conditions of uncertainty, reward and punishment. It has previously been found to be sensitive to damage to ventromedial pre-frontal cortex (Bechara, 2007; Bechara, Damasio, Damasio & Anderson, 1994). It takes about 15-20 minutes to complete. The game ends when 100 cards have been selected. The participant sits in front of a computer monitor on which are displayed 4 decks of cards (A, B, C, and D; see image 1).

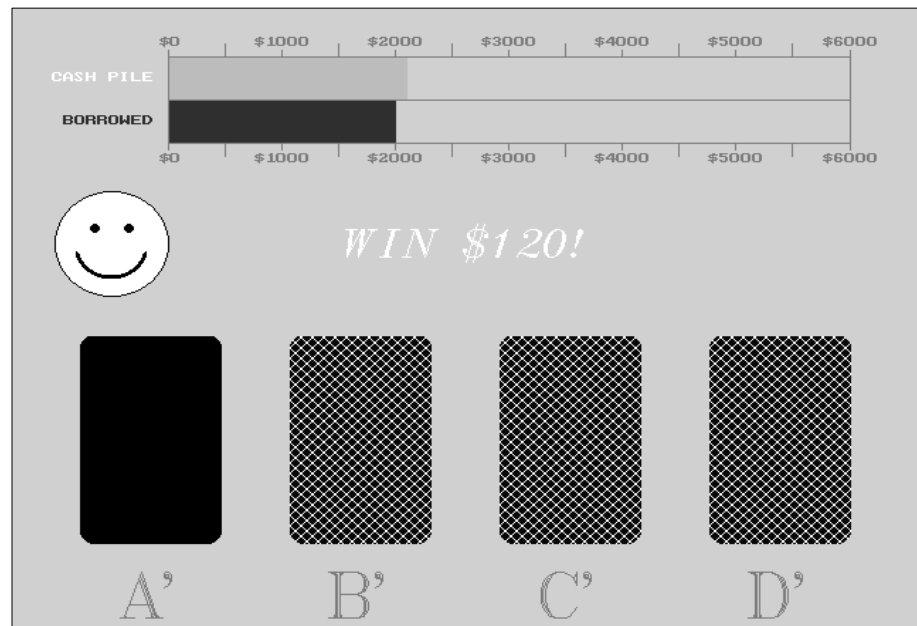

Image 1: Iowa Gambling Task screen image (after Bechara, 2007)

The participant selects a card from any deck by clicking on it using the mouse. Participants are given verbal instructions on how to play the game (see appendix VI). In short, the risky or disadvantageous decks (A and B) are similar with regards to overall net loss over the trials, although deck A is associated with more frequent punishment which is of a smaller magnitude. In contrast, deck B is associated with less frequent but higher magnitude punishment. While the

non-risky decks (C and D) are also similar in terms of overall net loss, they are different in two respects. Firstly, deck C is associated with punishment that is more frequent but of smaller magnitude. Secondly, deck D is associated with less frequent but greater magnitude punishment. Therefore, Decks A and B are “disadvantageous” because they result in an overall net loss in the long term, while decks C and D are “advantageous” because they lead to an overall gain in the long term (Bechara et al, 1994).

C. Data analysis

1. Key variables

The key externalising variables in this study were conduct disorder (CD), early onset alcohol abuse (EOAA), vm-PFC dysfunction (IGT), impulsivity (UPPS), chronically antisocial life style factor of psychopathy (PCL-F2) and violent antisociality (VA). These were operationalised as follows [in order to avoid confusion, the above abbreviations will be used throughout the method and results section]:

1.1 Conduct Disorder

This was measured using the IPDE dimensional scores for conduct disorder symptoms, of which fifteen are listed in the DSM-IV, giving a score out of 30. Dimensional scores were used rather than diagnostic categories for the following reasons. First, dimensional scores help preserve information that may be lost when the patients are grouped into diagnostic categories (Krueger & Finger, 2001). Second, some individuals in the negative category are not fundamentally different from those who meet the diagnostic criteria for conduct disorder due to fluctuation in the number of conduct disorder symptoms over time (Krueger et al., 2002). Finally, the

use of dimensional scores (continuous variable) improves statistical power through the use of parametric tests such as t-test and one way ANOVA. This was particularly important given the small sample size in this study.

1.2 Early Onset Alcohol Abuse

The threshold for early onset alcohol abuse was defined as consumption of 42 or more units of alcohol per week for at least 6 months continuously before age 20. This figure was based on reports from existing literature that vm-PFC of the brain requires 19 or 20 years to reach maturity. Hence, it remains susceptible to insults from environmental agents such as alcohol which when taken in large quantities before the age of 20 may impair the function of its ventro-medial part (Lumsden et al, 2005; Howard, 2006; 2009).

In the Lumsden et al study, the threshold for EOAA (i.e. consumption of 42 or more units of alcohol per week for at least 6 months continuously before the age 20) was based on a report by the Royal College of Psychiatrists (1986) which classed this level of alcohol intake to be 'hazardous and increased risk' levels (22 – 49 units per week) as compared with 'responsible or low risk' levels (0 – 21 units per week). I used the number of months in which the individual consumed 42 or more units of alcohol per week before the age 20 to derive a continuous measure of early-onset alcohol abuse (mean=21.19, SD=24.8). However, apart from being subject to recall bias, this measure also contained significant outliers (range 0-96). Therefore, this measure was supplemented with two other measures of EOAA; age when first tasted alcohol (mean =11.4,

SD=4.4) and age when first got drunk (mean=14.6, SD= 4.5). Information on these measures was based on self report and file review. The rationale for using these measures is that evidence suggests that measures of EOAA such as age of first drink have been associated with increased risk of antisocial behaviour in adulthood (Brems, Johnson, Neal and Freemon, 2004) and of disinhibitory psychopathology generally (Zernicke, Cantrell, Finn and Lucas, 2010). Early age of drinking onset has been also reported to strongly predict heavy alcohol consumption in young adulthood, even after controlling for preceding externalizing symptoms (Buchmann, Schmid, Blomeyer, Becker, Treutlein, Zimmermann et al., 2009).

In order to obtain a composite measure of EOAA, a weighted measure was derived using the sum of the weighted scores for the number of months in which the individual consumed 42 or more units of alcohol per week before age 20 (0=0 months, 1=1-19 months, 2=20-59 months, 3=more than 60 months); age when first tasted alcohol; and age when first got drunk (0=20 + years, 1=16-20 years, 2=11-15 years, 3=6-10 years, 4=5 years or younger). This measure produced a near normal distribution.

1.3 Vm-PFC Dysfunction

Vm-PFC dysfunction was measured using the scores on the Iowa Gambling Task (Bechara, 2007; Bechara, et al, 1994), more specifically the IGT Net score (total number of cards selected from advantageous decks (C+D) minus disadvantageous decks (A+B)) such that positive scores indicated advantageous performance and negative scores indicated the opposite. The cut-off score for

impairment was IGT Net Score < 10 , as indicated by the findings in individuals with ventro-medial prefrontal cortical lesion (Bechara et al., 2001). This method was used to calculate both the total scores and scores for five consecutive subsets each including 20 cards as follows: set 1 (cards 1-20); set 2 (cards 21-40); set 3 (cards 41-60); set 4 (cards 61-80); and set 5 (cards 81-100). The total score was used as the unit of analyses, while the data for the subsets was used to plot group performance on the task (see figure 2). It is worth noting that the mean IGT total scores for the sample contained significant outliers (median=-0.5, range= -60 to 80).

1.4 UPPS Impulsiveness

As mentioned earlier, impulsivity was measured using the UPPS Impulsive Behaviour Scale that has 4 subscales namely Premeditation, Urgency, Sensation seeking and Perseverance (Whiteside & Lynam, 2001). We used the total UPPS score as the unit of analysis. The data for the subscales and total scores followed a normal distribution.

1.5 Psychopathy

As mentioned earlier each of the 20 PCL-R items were rated as follows; 0=definitely not present, 1=present to some extent or 2=definitely present. The total PCL-R scores and scores on the 2 PCL-R factors (F1 and F2) were used as the unit of analysis.

1.6 Violent Antisociality

Considering that APD is known to comprise several sub-types (Poythress et al., 2010; Coid & Ullrich, 2010) and that offending history represents only one component of antisocial behaviour

(Farrington, 1995), a measure of violent antisociality (VA) derived from the above-mentioned violence and personality disorder (IPDE) assessments was used to capture the more severely antisocial end of the APD spectrum. The VA measure was derived from the following: (i) adult antisocial behaviour measured using the dimensional scores on adult antisocial personality disorder items of the IPDE (repeated acts that form grounds for arrest, repeated deceitfulness, impulsivity or failure to plan ahead, irritability and aggression, recklessness, consistent irresponsibility, and lack of remorse); (ii) violence quantity: operationalised as the total number of violent offences across life time including the index offence (s); and (iii) violence severity: measured using scores on the severity of violence in past criminal record. Since these measures correlated positively and significantly with each other ($p < 0.001$) they were reduced using Principle Component Analysis to produce a composite measure - VA. Principle Component Analysis yielded reasonably high values for Kaiser-Meyer-Olkin (0.63) and for Bartlett's test of sphericity ($X^2 = 57.047$, $p < 0.001$), indicating adequate sampling. A single factor solution explained about 62% of the variance observed. Components matrix revealed that these components loaded significantly onto the violence factor produced (adult antisocial behaviour=0.7, violence quantity=0.8, and violence severity=0.9).

2. Missing data

The dataset was almost complete apart from IGT and PCL-R factor scores (F1 & F2) data which were missing for 10 individuals. Multiple imputations method was used to replace the missing values (Little & Rubin, 2002). Multiple Imputation is a statistical procedure used to

analyse incomplete datasets. The procedure, which was originally proposed by Rubin (1987), entails three steps: first, imputation (filling in) of missing values m number of times (five in this study); second, analysis using the usual statistical tests embedded in the SPSS; and pooling the results of the analyses into a final set. These steps are usually carried out automatically by the SPSS such that the pooled results are presented in the output. Multiple imputation method is likely to produce better estimates than conventional approaches to missing data (such as listwise and pairwise deletion) even if the missing-at-random assumption is not met (Schafer & Graham, 2002). In this study, missing data were imputed using the algorithm in SPSS version 18. The full set of variables used in this paper was used for the imputation. Five imputations were calculated for each missing value and the averages of these imputations were used to replace the missing values.

3. Analytic strategy

The statistical analysis proceeded in two main stages as detailed below.

3.1 Stage One: Preliminary Analysis

This involved comparison by site and PD versus DSPD comparison. Analysis by site involved testing whether participants across the sites (Arnold Lodge, Rampton and Broadmoor) differed in terms of their historical, clinical and personality characteristics. Between-group comparisons on all variables were carried out using SPSS version 18. For continuous variables, the Kruskal Wallis test was used to compare medians of any variable found not to be normally distributed. Otherwise one way ANOVA was used to compare

means. The Tukey test was used in post hoc analysis. The chi-square statistic was used for all categorical variables.

PD versus DSPD comparison, which assessed whether DSPD individuals constitute an identifiable group, involved a comparison of patients admitted to DSPD units, who therefore meet the DSPD criteria, with patients not so admitted. For continuous variables, Mann Whitney U-tests were used to compare means on any variable found not to be normally distributed. Otherwise t-tests were used, provided the assumption of equal variances was confirmed. The chi-square statistic was used for all categorical variables.

In order to control for confounders, the effects of variables on which the groups differed were partialled out in regression analysis as described below.

3.2 Stage two: Testing The Hypothesis

This stage entailed testing the predictions that arise from Howard's hypothesis in three major steps as detailed below.

Step one: This step involved testing the prediction that when offenders with PD who have a history of early onset alcohol abuse are compared with those without such a history, they will score higher on measures of CD, IGT, UPPS, PCL-F2 and VA.

The sample was grouped into three groups as follows: (i) EOAA group (n = 42): those with a lifetime DSM-IV diagnosis of alcohol dependence/abuse, and a history of adolescent (before age 20) alcohol abuse comprising continuous use (over a 6-month period) of

at least 42 units of alcohol per week; (ii) late-onset alcohol abuse group (LOAA; n = 12): those with a lifetime DSM-IV diagnosis of alcohol dependence/abuse but with no history of adolescent alcohol abuse (they consumed fewer than 42 units of alcohol per week over any continuous 6-month period before age 20); (iii) nil history (n = 46): those with no lifetime DSM-IV diagnosis of alcohol dependence/abuse and with no history of adolescent alcohol abuse.

For continuous variables, the Kruskal Wallis test was used to compare means on any variable found not to be normally distributed. Otherwise one way ANOVA was used to compare means. The Tukey test was used in post hoc analysis. The chi-square statistic was used for all categorical variables. In order to control for confounders, the effects of variables on which the groups differed were partialled out in regression analysis as described below.

Step two: This step tested the prediction that EOAA will either moderate or mediate the link between conduct disorder and violent antisociality. Before conducting moderation or mediation analyses, I examined the relationship between CD, EOAA and VA using correlations and regression analyses (see tables 5 A and 5B). In the regression analysis CD and EOAA were treated as predictor variables and VA as outcome variable, after partialling out the effects of covariates including age, ADHD and regular/daily use of cannabis. The covariates which did not have significant effects on the parameters of the regression analysis were excluded from final analyses, described below.

Then I explored the extent to which EOAA moderated the effect of CD on VA. According to Hayes and Matthes (2009) "*A moderated effect of some focal variable F on outcome variable Y is one in which its size or direction depends on the value of a third, moderator variable M. Analytically, moderated effects reveal themselves statistically as an interaction between F and M in a mathematical model of Y.*" In other words, if variable F is presumed to cause variable Y, a moderator variable is one which alters (amplifies, attenuates or even reverses) the effect of F on Y (see figure 2). Several statistical models have been proposed to test moderation in multiple regression equation. In this study moderation was examined using Modprobe, an aid used to test interactions in ordinary least squares (OLS) and logistic regression (Hayes & Matthes, 2009). It estimates model coefficients and standard errors in a model including a focal predictor (e.g. CD), a moderating predictor (e.g. EOAA), the product of the two (i.e. interaction), and any additional covariates (e.g. age and life time regular or daily use of cannabis) to estimate the outcome variable (VA). In addition to estimating the coefficients of the model, it also conducts simple slopes analysis, or tests of the conditional effect of the focal predictor on dependent variable at values of moderator variable (low, medium and high).

I then used a multiple mediation procedure developed by Preacher & Hayes (2008) to test the prediction that EOAA will mediate, at least in part, the relationship between CD and VA. According to Preacher and Hayes (2008), mediation hypotheses "*posit how, or by what means, an independent variable (X) affects dependent variable (Y) through one or more intervening variables, or*

mediators (M).” In its simplest form, mediation analysis involves testing how the independent variable (IV) affects dependent variable (DV) through a mediator variable (M) – also called simple mediation (see figure 2). In this model, a number of paths are quantified using unstandardized coefficients. Path *a* represents the effect of IV on *M*. Path *b* represents the effect of *M* on *DV* after controlling for the effect of IV. Path *ab* which is estimated as the product of *a* and *b* represents the total indirect effect of IV on *DV* through *M*. Path *c'* is the direct effect of IV on *DV*. Path *c* which represents the total effect of IV on *DV* is the sum of the direct and indirect effects (i.e. $ab + c'$). When IV no longer affects *DV* after *M* has been cancelled (i.e. path *c'* is zero), mediation is referred to as complete mediation. In contrast, mediation is referred to as partial mediation when path *c'* is still different from zero when the mediator is cancelled (Baron & Kenny, 1986).

Several approaches have been advocated for testing the mediation. For instance, the approach proposed by Baron and Kenny (1986) sets out to test the extent to which certain predictions concerning the aforementioned paths hold true, whereas the Sobel test (Sobel, 1982) involves computing the ratio of *ab* to its estimated standard error, producing p values for this ratio which, at significant values, denote mediation. In situations where the researcher has in mind a number of proposed mediator variables, several simple mediation analyses are conducted to explain the relationship between IV and DV.

In the mediation analysis I initially estimated the direct, indirect and total effects of CD (independent variable) on VA (dependent

variable) through EOAA (proposed mediator). Sobel test (Sobel, 1982) values for the total and specific indirect effects of CD on VA were estimated. The analysis was then repeated after controlling for covariates.

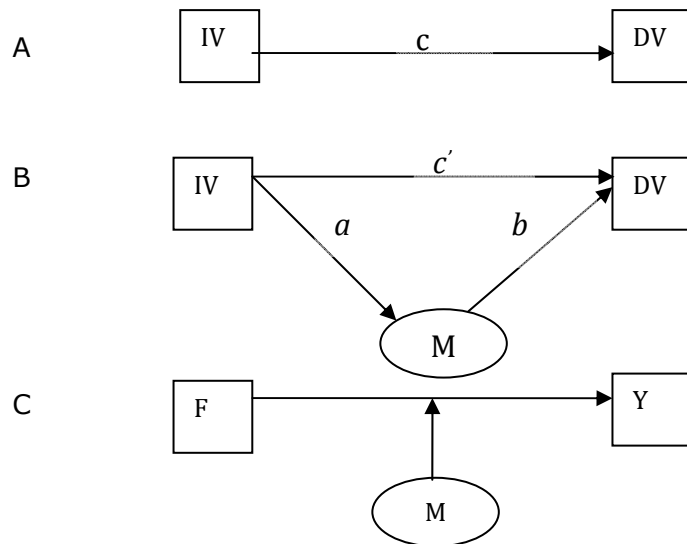

Figure 2: Mediation (after Preacher & Hayes, 2008) and moderation (after Hayes & Matthes, 2009) models. Figure 2A depicts the total effect of IV on DV (path c). Figure 2B depicts the direct effect of IV on DV (path c' or c prime) and the indirect effect of IV on DV through the proposed mediator (path ab). Figure 2C depicts the moderated effect of a focal predictor F and outcome variable Y through moderator variable M .

Step three: in this step of the analysis, I tested the prediction that UPPS, IGT and PCL-R factor 2 will either moderate or mediate the link between EOAA and VA.

Before conducting moderation or mediation analyses, I initially examined the relationship between the key externalizing variables in correlations and regression analyses. Using Pearson's correlations, I examined whether CD, EOAA, IGT, UPPS, PCL-F2 and violent antisociality (VA), will correlate significantly with each other

(see table 5A and 5B). Then using multiple linear regression analysis I examined the relationship between these variables using VA as the dependent variable and the rest as predictor variables. The aim was to assess whether the predictor variables would significantly predict VA. Since PCL-F2 taps into disinhibitory behaviours which start from an early age including conduct problems, it was anticipated that the effects of CD on VA would be superseded by PCL-F2. Since this finding was confirmed in the regression analysis (see below), CD was excluded from subsequent analyses.

I then explored the moderating effects of IGT, PCL-F2 and UPPS on EOAA in relation to VA. The analysis tested various models using EOAA, IGT, PCL-F2 and UPPS as predictor or moderator variables and VA as outcome variable.

Using multiple mediation analysis, I then explored the mediating effects of EOAA, IGT, PCL-F2 and UPPS in relation to VA. Several mediation models were tested as described below. Mediation analysis was assessed using the multiple mediation model proposed by Preacher & Hayes (2008). This approach has the advantage of avoiding problems associated with simple mediation analysis such as 'omitted variables problem' which may produce biased parameter estimates (Preacher & Hayes, 2008). It also allows for several mediators and covariates (as in this study) to be entered into the analysis simultaneously. I used this approach to test four different multiple mediation models using EOAA, PCL-F2, IGT and UPPS as either predictor or mediator variables and VA as dependent variable. For each model I estimated the direct (c' path or c prime),

indirect (ab path) and total (c path) effects of the independent variables on VA (dependent variable) through proposed mediators. For each model I calculated the Sobel test values for the total and specific indirect effects of independent variables on VA.

The data were analysed using the SPSS version 18. Moderation and mediation analyses were tested using corresponding macros obtained from www.afhayes.com.

D. Ethics and Consent

North and East Nottinghamshire research ethics committee granted approval to conduct the study. Written informed consent was obtained from all participants. A copy of participants information sheet and consent form is appended (see appendices VII and VIII). Arnold Lodge participants were paid a £10 gift voucher for their participation in the study. Funding is detailed under acknowledgements.

CHAPTER FOUR

RESULTS

A. Sample Characteristics

1. General

Of the 125 patients who were invited to participate in the study, 114 consented to take part. Two participants withdrew their consent at a later stage, giving a response rate of 89.6%. Of the 112 participants recruited into the study, 12 were excluded from the analysis because of missing data. The final sample comprised 100 participants recruited from the personality disorder services at Arnold Lodge Regional Secure Unit (n=31), Broadmoor hospital (n=25), and Rampton hospital (n=44). Out of the 69 high-secure patients, 38 were housed in pilot units for the assessment and treatment of "dangerous and severe personality disorder" (DSPD).

2. Socio-Demographics

Patients' mean age at the time of assessment was 35.2 years (SD = 9.2; range 21 to 64) and at the time of committing the index offence was 26 (SD=7.2; range 14 to 45) years. The majority were of white ethnicity (91%) and never married (81%). A large proportion received institutional care in local authorities before the age of 18 (60%). The mean years lived apart from biological mother before the age of 14 was 4.8 (SD=5.4; range 0-14) and mean years lived apart from biological father was 3.5 (SD=4.7; range 0-14). Most (42%) had no educational qualifications; 38% attained junior qualifications such as GCSE, vocational qualifications and diplomas; and the remainder (20%) attained higher qualifications such as A 'levels or equivalents.

3. Psychopathology and Substance Misuse

Most (91%) had received a DSM-IV diagnosis of Cluster B (antisocial PD (72%), borderline PD (47%), histrionic PD (7%), narcissistic PD (13%)), with a significant proportion receiving Cluster A (45%) or Cluster C (42%) diagnoses. The mean number of personality disorder diagnoses was 2.9 (SD = 1.5; range 1 to 8). Mean personality cluster dimensional scores were the highest for Cluster B (40.2, SD=15.2; range 6 to 73), followed next by Cluster A (10.2, SD=6.9; range 0 to 29) and Cluster C (9.2, SD=6.5; range 0 to 31). Almost half (48%) were classified in terms of Tyrer and Johnson's severity scale (1996) as "severe" (48%). The remainder (52%) were classified as "personality difficulty" (9%), "simple personality disorder" (39%), or "diffuse personality disorder" (5%).

A large proportion received co-morbid lifetime diagnoses of major depression and alcohol abuse/dependence (56% and 58% respectively). Over half (54%) were in receipt of psychotropic medication at the time of assessment including antipsychotics (30%), antidepressants (21%), and others such as benzodiazepines (22%). Regarding illicit drugs misuse (daily and/or regular use); cannabis was the most commonly abused illicit drug (67%), followed next by stimulants (43%), opiates (28%), and hallucinogens (17%).

4. Key variables

1.1 CD: A large proportion had a history of DSM-IV childhood conduct disorder (76%), and a minority (25%) additionally had a diagnosis of childhood ADHD. The mean conduct disorder dimensional score for the sample was 12.2 (SD=7; range 0 to 30).

1.2 EOAA: More than half (54%) met the DSM-IV diagnosis of alcohol abuse/dependence. Participants had a history of early drinking, starting from a young age: mean age when first tasted alcohol was 11.4 (SD=4.4; range 1 to 29), and mean age when first got drunk was 14.6 (SD=4.5; range 3 to 33). The number of months in which the individual consumed ≥ 42 units of alcohol per week before age 20 was 21.19 (SD=24.8; range 0-96). The mean weighted score for early-onset alcohol abuse (out of 15 as described above) was 5.2 (SD=2.2; range 0 to 11).

1.3 Psychopathy: Almost half (49%) the sample met the European cut-off for psychopathy (PCL-R score ≥ 25). The mean PCL-R total score for the sample was just below the European cut-off point (24.2, SD=6.9; range 1 to 35). The mean PCL-R factor scores were: Factor 1= 9.2 (SD=3.8; range 0 to 16), Factor 2 = 12.9 (SD=3.8; range 1 to 18).

1.4 IGT: Vm-PFC dysfunction was indexed by an IGT Net Score of less than 10. Performance on the Iowa Gambling Task (IGT) yielded a median absolute score (the difference between the number of advantageous and disadvantageous cards selected by participants) of -0.5 (range -60, 80), indicating an overall impairment in vm-PFC functioning. A significant proportion of the participants (78%) scored in the impaired range on the IGT (Net score < 10).

1.5 VA: Patients had a history of chronic offending, with a mean number of 33 lifetime offences (range 1-154) and of 12.5 violent

offences (range 1-135). All patients had a history of mostly violent offending starting from a young age: mean age of first offence was 15 years (SD = 4.5; range 10 to 36), and of first violent offence, 18 years (SD = 5.1; range 11 to 36). Scores on the DSM-IV adult antisocial personality disorder items (out of 14 on 7 items) revealed a mean dimensional score of 9.8 (SD=3; range 2 to 14). Scores on the violence rating scale (Gunn & Robertson, 1993; Wong et al, 1995) were as follows: index offence 2.7 (SD=1; range 0 to 4), previous criminal record 2.3 (1.1; range 0 to 4), institutional behaviour 1.6 (1.2; range 0 to 4), and total score 6.8 (2.1; range 2 to 12).

1.6 UPPS: Scores on the UPPS impulsive Behaviour Scale (Whiteside & Lynam, 2001) yielded a mean total UPPS score of 111 (SD=24.2; range 13 to 165) and means scores on the subscales as follows: lack of premeditation 25.4 (SD=7.6; range 11 to 41), urgency 32.5 (SD=8.7; range 12 to 48), sensation seeking 32 (SD=8.5; range 12 to 48), and lack of perseverance 22 (SD=6.4; range 10 to 40).

B. Comparison By Site

Results of comparison by site (Arnold Lodge, Broadmoor and Rampton) are presented in table 2 below. Groups did not differ on IQ, age at index offence, socio-demographics (except for age at the time of assessment; see below), the use of illicit drugs (regular and daily use), the use of prescribed psychotropic medications, personality psychopathology (as measured using the IPDE), personality disorder severity, PCL-R scores including scores on Factors 1 and 2, IGT performance, and conduct disorder dimensional scores. However, significant between-site differences

were found for the following measures: (i) age at the time of assessment ($F=10.462$, $p < 0.001$) with Arnold Lodge participants being younger than high security participants; (ii) weighted measures of EOAA ($F = 5.829$, $p = 0.004$), with the Arnold Lodge group scoring higher than Rampton group; (iii) UPPS impulsiveness total scores ($F=3.907$, $p=0.023$) with Arnold Lodge patients scoring higher than participants at high security hospitals; and (iv) violent antisociality, with Arnold Lodge patients scoring higher than Broadmoor patients ($F=4.575$, $p=0.013$). It is noteworthy that the group at Arnold Lodge also had a significantly greater prevalence of ADHD ($X^2=13.196$, $p=0.001$) and lifetime alcohol abuse/dependence ($X^2=14.405$, $p=0.001$). However, Rampton hospital participants (as compared with Arnold Lodge and Broadmoor participants) showed greater prevalence of major depression ($X^2=21.702$, $p<0.001$) and conduct disorder ($X^2=7.878$, $p=0.019$); and scored higher on the violence rating scale.

	Arnold Lodge n= 31	Rampton n= 44	Broadmoor n= 25	Sig.
Demographics and IQ				
Mean age at assessment (SD)	29.6 _{a,b} (5.4)	38.5 (9.6)	36 (8.9)	$F= 10.462$, $p<0.001$
Mean age at index offence (SD)	25 (4.5)	27.2 (8.0)	25 (8.3)	$F=1.272$, $p=0.285$
White Ethnicity N (%)	27 (29.7)	42 (46.2)	22 (24.2)	$LR= 2.048$, $p=0.35$
Never married N (%)	25 (30.9)	32 (39.5)	24 (29.6)	$LR=9.721$, 0.28
Median years lived apart from biological father (range) ¹	3 (0-14)	4 (0-14)	0 (0-14)	$P=0.08$
Median years lived apart from biological mother (range) ¹	2 (0-14)	1 (0-14)	0 (0-14)	$P=0.55$
Mean full scale IQ (SD)	89.9 (12.6)	89.3 (13.1)	91.8 (12.4)	$F=0.315$, $p=0.731$
Substance misuse history: regular/daily use of: N (%)				

	Arnold Lodge n= 31	Rampton n= 44	Broadmoor n= 25	Sig.
Cannabis	25 (37.3)	28 (41.8)	14 (20.9)	LR=5.876, p=0.209
Stimulants	17 (39.5)	16 (37.2)	10 (23.3)	LR=5.509, p=0.239
Opiates	11 (39.3)	11 (39.3)	6 (21.4)	$\chi^2=1.256$, p=0.534
Hallucinogens	3 (17.6)	11 (64.7)	3 (17.6)	$\chi^2=3.617$, p=0.164
Psychotropic medication use, n (%)				
Any	18 (33.3)	23 (42.6)	13 (24.1)	$\chi^2=0.299$, p=0.861
Antidepressants	9 (42.9)	7 (33.3)	5 (23.8)	$\chi^2=1.908$, p=0.385
Antipsychotics	14 (46.7)	11 (36.7)	5 (16.7)	$\chi^2=5.108$, p=0.078
C-DIS diagnoses, n (%)				
Major depression	22 (39.3)	30 (53.6)	4 (7.1)	$\chi^2=21.702$, p<0.001
Conduct disorder	27 (35.5)	35 (46.1)	14 (18.4)	$\chi^2=7.878$, p=0.019
ADHD	13 (52)	12 (48)	0	$\chi^2=13.196$, p=0.001
Alcohol dependence	23 (50)	15 (32.6)	8 (17.4)	$\chi^2=14.405$, p=0.001
IPDE				
Cluster A diagnosis, n (%)	15 (33.3)	21 (46.7)	9 (20)	$\chi^2=1.094$, p=0.579
Cluster B diagnosis, n (%)	28 (30.8)	42 (46.2)	21 (23.1)	LR=2.540, p=0.281
Cluster C diagnosis, n (%)	17 (40.5)	17 (40.5)	8 (19)	$\chi^2=3.328$, p=0.189
Mean Cluster A dimensional scores (SD)	9.6 (5.4)	11 (6.9)	9.4 (8.4)	F=0.580, p=0.562
Mean Cluster B dimensional scores (SD)	43.2 (16.5)	40.5 (15.1)	36 (13.1)	F=1.592, p=0.209
Mean Cluster C dimensional scores (SD)	11.3 (6.4)	8.6 (6)	7.8 (7)	F=2.562, p=0.08
PD severity				
Severe	15 (31.3)	22 (45.8)	11 (22.9)	$\chi^2=0.233$, p=0.89

	Arnold Lodge n= 31	Rampton n= 44	Broadmoor n= 25	Sig.
Early onset alcohol abuse				
Mean EOAA weighted scores (SD)	6.2 _a (1.6)	4.5 (2.3)	5 (2.2)	F=5.829, p=0.004
Mean PCL-R scores (SD)				
Total score	24.1 (5.4)	24.1 (7)	24.4 (8.4)	F=0.012, p=0.989
Factor 1	9.2 (3.7)	8.9 (3.8)	9.6 (4.0)	F=0.273, p=0.790
Factor 2	13.2 (3.4)	13.1 (3.6)	11.9 (4.6)	F=0.554, p=0.576
Impulsiveness				
Mean UPPS total scores (SD)	120.7 _{a,b} (27.3)	107.1 (22.8)	105.7 (18.4)	F=3.907, p=0.023
Vm-PFC dysfunction				
Median IGT ¹ Net Scores (range)	-2 (-59 – 80)	-2 (-60 -52)	0 -65 (74)	0.74
IGT impairment N (%)	23 (29.5)	36 (46.2)	19 (24.4)	$\chi^2=0.694$, p=0.707
Antisocial behaviour				
	Mean (SD)	Mean (SD)	Mean (SD)	
Mean CD dimensional scores (SD)	13.8 (7.5)	12.6 (6.8)	9.6 (6.3)	F=2.633, p=0.077
<i>Mean Violent antisociality scores (SD)</i>	0.37 _b (0.9)	-0.01 (0.9)	-0.042 (1)	F=4.575, p=0.031

Table 2: comparison by site: *a* indicates Arnold Lodge significantly different from Rampton; *b* indicates Arnold Lodge significantly different from Broadmoor; *c* indicates that Rampton significantly different from Arnold Lodge and Broadmoor. LR=Likelihood Ratio; ¹ Kruskal Wallace Test.

C. Do DSPD patients differ from PD patients in terms of their clinical characteristics?

As may be seen from table 3, the profiles of PD and DSPD groups in terms of demographics, criminal history, personality, and clinical characteristics appear remarkably similar, with a few notable exceptions. First, the DSPD group showed more psychopathic personality traits as measured by PCL-R,

on both interpersonal/affective ($t=-4.526$, $p<0.001$) and unstable/antisocial lifestyle ($t=-2.885$, $p=0.005$) factors. Second, the DSPD group were older at the time of committing the index offence ($t=-2.493$, $p=0.014$). Third, the DSPD group showed a greater prevalence of regular and daily hallucinogens use history ($X^2=6.200$, $p=0.013$). The personality profiles of PD and DSPD groups were similar apart from fewer Cluster C traits in the DSPD group ($X^2=6.189$, $p=0.013$) who showed lower Cluster C dimensional scores ($t=2.330$, $p=0.022$). There was no evidence that DSPD patients suffered from a more severe personality disorder than PD patients.

	PD sample n= 62	DSPD sample n= 38	Mean diff. 95% CI	Sig.
Demographics and IQ				
Mean age at assessment (SD)	33.9 (9.2)	37.1 (8.8)	-3.2 (-6.9, 0.4)	$t=-1.736$, $p=0.086$
Mean age at index offence (SD)	24.6 (6.5)	28.2 (7.8)	-3.6 (-6.5, -0.7)	$t=-2.493$, $p=0.014$
	Median (range)	Median (range)	-	
Median years lived apart from biological father (range) ¹	1 (0-14)	1 (0-14)	-	$U=1066.5$, $p=0.547$
Median years lived apart from biological mother (range) ¹	2 (0-14)	1 (0-14)	-	$U=990$, $p=0.234$
Mean full scale IQ (SD)	89.5 (12.2)	91 (13.6)	-1.4 (-6.7, 3.7)	$t=-0.565$, $p=0.573$
Substance misuse history:				
regular/daily use of: n (%)				
Cannabis	40 (59.7)	27 (40.3)	-	$X^2=0.455$, $p=0.5$
Stimulants	24 (54.5)	20 (45.5)	-	$X^2=1.853$, $p=0.173$
Opiates	17 (60.7)	11 (39.3)	-	$X^2=0.027$, $p=0.869$
Hallucinogens	6 (35.3)	11 (64.7)	-	$X^2=6.200$, $p=0.013$

	PD sample n= 62	DSPD sample n= 38	Mean diff. 95% CI	Sig.
Psychotropic Medication, n (%)				
Any	34 (63)	20 (37)	-	$X^2=0.046$, $p=0.83$
Antidepressants	15 (71.4)	6 (28.6)	-	$X^2=1.003$, $p=0.317$
Antipsychotics	22 (73.3)	8 (26.7)	-	$X^2=2.336$, $p=0.126$
C-DIS diagnoses n (%)				
Major depression	36 (64.3)	20 (35.7)	-	$X^2=0.282$, $p=0.595$
Conduct disorder	48 (63.2)	28 (36.8)	-	$X^2=0.180$, $p=0.671$
ADHD	17 (68)	8 (32)	-	$X^2=0.509$, $p=0.475$
Alcohol dependence	31 (76.4)	15 (32.6)	-	$X^2=1.051$, $p=0.305$
IPDE				
Cluster A diagnosis, n (%)	30 (66.7)	15 (33.3)	-	$X^2=0.756$, $p=0.384$
Cluster B diagnosis, n (%)	55 (60.4)	36 (39.6)	-	$X^2=1.045$, $p=0.307$
Cluster C diagnosis, n (%)	32 (76.2)	10 (23.8)	-	$X^2=6.189$, $p=0.013$
Mean Cluster A dimensional scores (SD)	10.2 (6.1)	10.2 (8)	0.02 (-2.8, 2.8)	$t=0.015$, $p=0.098$
Cluster B dimensional scores (SD)	38.5 (14.8)	43 (15.6)	-4.5 (-10.7, 1.6)	$t=-1.454$, $p=0.149$
Cluster C dimensional scores (SD)	10.4 (6.5)	7.3 (6.1)	3 (1.3, 0.4)	$t=2.330$, $p=0.022$
PD severity				
Severe, n (%)	31 (64.6)	17 (35.4)	-	$X^2=0.261$, $p=0.609$
Early onset alcohol abuse				
Mean EOAA weighted scores (SD)	5.3 (1.9)	4.9 (2.7)	0.3 (-0.5, 1.3)	$t=0.848$, $p=0.437$
Mean PCL-R scores (SD)				
Total score	21.6 (6.9)	28.3 (4.5)	-6.6 (-9.1, -4.1)	$t=-5.298$, $p<0.001$
Factor 1	7.9 (3.8)	11.2 (2.9)	-3.2 (-4.7, -1.8)	$t=-4.526$, $p<0.001$

	PD sample n= 62	DSPD sample n= 38	Mean diff. 95% CI	Sig.
Factor 2	12.1 (3.9)	14.3 (3)	-2.1 (-3.6, -0.6)	t=-2.885, p=0.005
Impulsiveness				
Mean UPPS total scores (SD)	111.3 (24.7)	110.3 (23.2)	0.9 (-8.9, 10.8)	t=0.193, p=0.848
Vm-PFC dysfunction				
Mean IGT Net Scores (SD) ¹	1.7 (3)	1.7 (0.2)	-0.02 (-0.13, 0.09)	z=-0.064, p=0.949
IGT impairment N (%)	49 (62.9)	29 (37.2)		$\chi^2=0.101$, p=0.750
Antisocial behaviour				
	Mean (SD)	Mean (SD)	-	
Mean CD dimensional scores (SD)	12.3 (6.7)	12.1 (7.5)	0.2 (-2.6, 3.1)	t=0.175, p=0.862
<i>Mean Violent antisociality scores (SD)</i>	-0.07 (1.1)	0.11 (0.7)	-0.19 (-0.5, 0.1)	t=-0.917, p=0.318

Table 3: Comparisons between PD and DSPD groups on offending, personality and clinical variables. Bold type-face p values indicate significant differences. ¹ Mann Whitney tests.

D. Testing The Hypothesis

The three major predictions that arose from the hypothesis (Howard, 2006) were tested in steps as described below.

1. Between Groups Comparisons.

Comparison of group (EOAA v LOAA v nil history) demographics, personality profiles and clinical characteristics revealed that the groups did not differ on IQ, number of years lived apart from biological parents before age 14 age, use of psychotropic medications, prevalence of Axis I disorders, IPDE diagnoses (except for Cluster B dimensional scores), history of illicit drug use (except for cannabis as described below), PD severity, and both PCL total and PCL-F1 scores. However, significant between-group differences were found for age at time of assessment

($F=6.75$, $p=0.002$), age at index offence ($F=4.72$, $p=0.011$), regular and/ or daily use of cannabis ($\chi^2=14.649$, $p=0.001$), and IPDE Cluster B dimensional scores ($F=4.151$, $p=0.019$), the EOAA and late onset alcohol abuse groups were remarkably similar.

As predicted, the EOAA group scored higher than the nil history group on CD dimensional scores ($F=3.866$, $p=0.024$), the social deviance factor of psychopathy (PCL-F2; $F=2.403$, $p=0.018$), impulsiveness ($F=5.798$, $p=0.004$) and violent antisociality ($F=4.795$, $p=0.01$). However, groups did not differ on IGT ($\chi^2=2.952$, $p=0.229$).

	Nil history n= 46	LOAA n= 12	EOAA n=42	Sig.
Demographics and IQ				
Mean age at assessment (SD)	37 (9.5)	40.5 (6.7)	31.7 _{a,b} (8)	$F=6.75$, $p=0.002$
Mean age at index offence (SD)	25.8 (7.4)	31.7 (7.8)	24.7 _b (6.2)	$F=4.72$, $p=0.011$
Mean years lived apart from biological father (SD) ¹	4.8 (4.9)	5.5 (6)	5.6 (5.7)	$\chi^2=3.099$, $p=0.212$
Mean years lived apart from biological mother (SD) ¹	3.5 (4.8)	3.5 (4.5)	4.6 (5.9)	$\chi^2=0.275$, $p=0.872$
Mean full scale IQ (SD)	90.6 (14)	88.9 (12.5)	89.9 (11.5)	$F=0.098$, $p=0.907$
Substance misuse history: regular/daily use of: n (%)				
Cannabis	22 (32.8)	9 (13.4)	36 (53.7)	$\chi^2=14.649$, $p=0.001$
Stimulants	14 (34.1)	5 (12.2)	22 (53.7)	$\chi^2=4.374$, $p=0.112$
Opiates	8 (27.6)	4 (13.8)	17 (58.6)	$\chi^2=5.806$, $p=0.055$
Hallucinogens	6 (35.3)	3 (17.6)	8 (47.1)	$\chi^2=1.179$, $p=0.554$

	Nil history n= 46	LOAA n= 12	EOAA n=42	Sig.
Psychotropic Medication use N (%)				
Any	23 (42.6)	8 (14.8)	23 (46.2)	$\chi^2=1.081$, p=0.582
Antidepressants	8 (38.1)	2 (9.5)	11 (52.4)	$\chi^2=1.179$, p=0.555
Antipsychotics	10 (33.3)	5 (16.7)	15 (50)	$\chi^2=2.926$, p=0.232
C-DIS diagnoses N (%)				
Major depression	26 (47.3)	5 (9.1)	24 (43.6)	$\chi^2=0.983$, p=0.612
Conduct disorder	33 (43.4)	7 (9.2)	36 (47.4)	$\chi^2=4.684$, p=0.096
ADHD	8 (32)	2 (8)	15 (60)	$\chi^2=4.436$, p=0.109
IPDE				
Cluster A diagnosis, n (%)	19 (42.2)	8 (17.8)	18 (40)	$\chi^2=2.608$, p=0.271
Cluster B diagnosis, n (%)	40 (44)	11 (12)	40 (44)	$\chi^2=1.846$, p=0.397
Cluster C diagnosis, n (%)	16 (38.1)	5 (11.9)	21 (50)	$\chi^2=2.088$, p=0.352
Mean Cluster A dimensional scores (SD)	9.7 (7)	12.8 (7.5)	10.1 (6.7)	F=1.01, p=0.368
Mean Cluster B dimensional scores (SD)	35.7 (14.6)	44.3 (16.2)	44.1 _a (14.7)	F=4.151, p=0.019
Mean Cluster C dimensional scores (SD)	8.1 (6.4)	10.4 (5.6)	10.2 (6.9)	F=1.310, p=0.274
PD severity				
Severe, n (%)	22 (45.8)	6 (12.5)	20 (41.7)	$\chi^2=0.022$, p=0.989
Mean number of PD diagnosis (SD)	2.7 (1.5)	3.2 (1.4)	2.9 (1.4)	F=0.672, p=0.513
Mean PCL-R scores (SD)				
Total PCL-R	23.7 (8.2)	23.2 (6.7)	25.1 (5.2)	F=0.614 P=0.543
PCL-F1	8.9 (4)	9.2 (4.1)	9.5 (3.5)	F=0.344, p=0.710

	Nil history n= 46	LOAA n= 12	EOAA n=42	Sig.
PCL-F2	12.3 (4.4)	11.5 (3.5)	14 _{a, b} (2.8)	F=3.266, p=0.042
Impulsiveness				
Mean UPPS total scores (SD)	102.9 (23)	111.3 (9.3)	119.6 _a (25.4)	F=5.798, p=0.004
Vm-PFC dysfunction				
Mean IGT ¹ Net Scores (SD)	5.6 (29.9)	1.3 (29.2)	-4.9 (20.4)	X ² =2.952, p=0.229
IGT impairment n (%)	33 (42.3)	10 (12.8)	35 (44.9)	X ² =1.946, p=0.378
Antisocial behaviour				
Mean CD dimensional scores (SD)	10.6 (6.5)	11 (7.1)	14.5 _a (7.1)	F=3.866, p=0.024
<i>Mean violent antisociality scores (SD)</i>	-0.26 (0.9)	-0.25 (1)	0.36 _a (0.9)	F=4.795, p=0.01

Table 4: Comparison by history of alcohol abuse: *a* indicates that EOAA is significantly different from nil history; *b* EOAA is significantly different from late onset; *c* indicates that late onset is significantly different from nil history. ¹ Kruskal Wallace Test.

But, when the absolute scores of the IGT by subsets (each represented a set of 20 cards chosen by participants) were plotted by group, some interesting findings emerged (see figure 4). As may be seen from the figure, the performance of the nil history group improved after the first set of 20 cards and continued to improve towards the end of the game, indicating that as the game progressed they learned to avoid the disadvantageous or risky choices (i.e. decks A and B). In contrast, the performance of the EOAA group yielded negative absolute scores on all the subsets apart from the second subset, indicating that they continued to make risky choices despite negative consequences. The performance of the late onset group was also disadvantageous and broadly similar to the EOAA group. However, comparison of mean scores for subsets using one way ANOVA showed significant between

groups differences only for the third and fifth subsets ($p=0.037$ and 0.009 respectively).

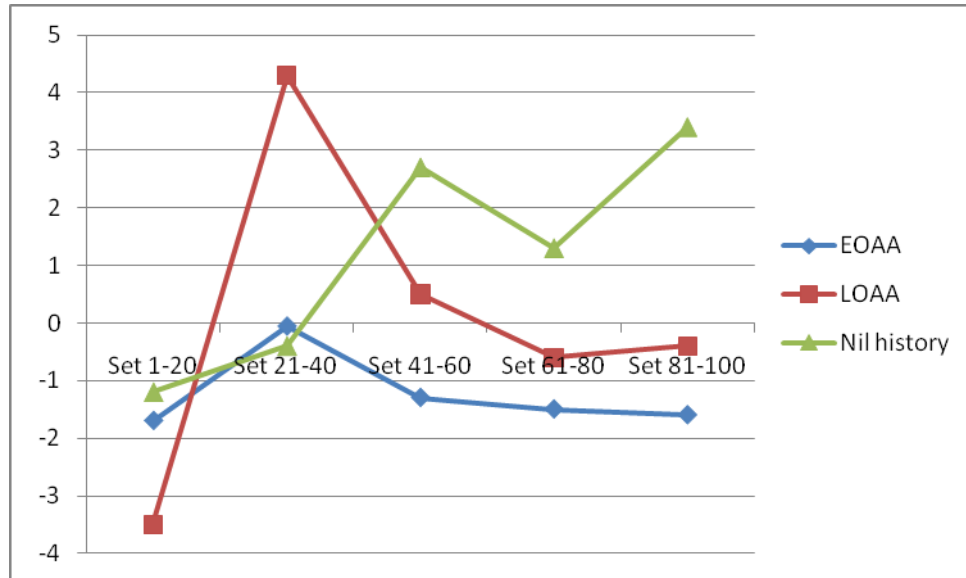

Figure 3: performance on IGT by groups.

2. Did Early Onset Alcohol Abuse Moderate The Effect of CD On Violent Antisociality?

Initially, the relationship between CD, EOAA and VA was examined using correlational analysis and linear regression. This revealed that EOAA correlated positively and significantly with CD ($r^2= 0.376$, $p < 0.001$) and VA scores ($r^2= 0.374$, $p < 0.001$). The highest correlation was between CD and VA scores ($r^2= 0.399$, $p < 0.001$). Multiple regression analysis revealed that both CD ($\beta=0.301$, $p=0.003$) and EOAA ($\beta=0.261$, $p=0.008$) significantly predicted VA. Tests for multicollinearity (e.g. Menard, 1995; Myers, 1990) showed acceptable tolerance and VIF values (0.86 and 1.2 respectively) indicating that multicollinearity between the predictor variables was unlikely. The effects of CD ($\beta=-0.275$, $p=0.007$), and EOAA ($\beta=0.215$, $p=0.045$) on VA remained significant after partialling out the effects of covariates: namely age ($\beta=-0.008$, $p=0.938$), and regular/daily use of cannabis

($\beta=0.067$, $p=0.5$) and ADHD ($\beta=0.117$, $p=0.221$). Since age at time of assessment, cannabis and ADHD did not show significant effects on the parameters of the regression model they were excluded from the final regression model and from subsequent analyses.

Results of the moderation analysis using Modprobe (Hayes & Matthes, 2009) indicated that the model accounted for a small proportion of the variance in the relationship between CD and VA ($r^2=0.2177$, $F=8.9065$, $p<0.0001$). However, the interaction term for CD and EOAA was not significant, indicating that EOAA did not moderate the effect of CD on VA.

3. Did Early Onset Alcohol Abuse Mediate The Effect of CD On Violent Antisociality?

Results of multiple mediation analysis (Preacher & Hayes, 2008) indicated that EOAA significantly mediated the effect of CD on VA (Sobel's $Z= 2.8278$, $p=0.0047$). The indirect effect of CD on violent antisociality through the proposed mediator remained significant even after partialling out the effect of covariates including age, cannabis use and ADHD. Since the partial effects of covariates on dependent variable (VA) were not significant, the covariates were excluded from the final model ($r^2=0.2177$, $F=13.4982$, $p<0.001$; see figure 4).

4. Relationships Between Externalizing-Related Variables (ERVs) and Between ERVs and Other Variables.

Inter-correlations between externalizing-related variables are shown in Table 5A. It may be seen that most externalizing-related variables correlated significantly with one another. There are however some exceptions. For instance, PCL F1 doesn't correlate with CD and EOAA

and IGT fails to show significant correlations. Notable is the high and significant correlations between PCL F2 and the violence related measures: VA, violence severity and quantity. PCL F2 correlated significantly with all UPPS scales with the exception of (lack of) Perseverance. PCL- F1 correlated less highly than F2 with UPPS measures, with the exception of Sensation Seeking, which correlated significantly with F1 ($p < 0.01$).

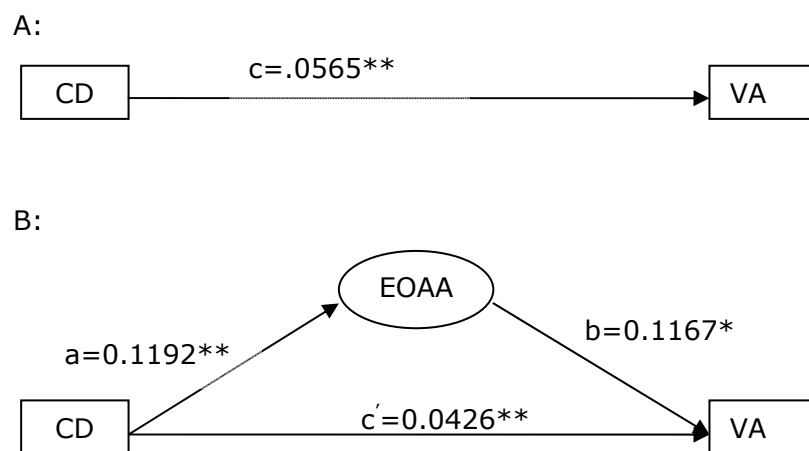

Figure 4: Multiple Mediation Model 1 (after Preacher & Hayes, 2008): Figure 1A shows the total effect of CD (independent variable) on VA (outcome variable) - path c. Figure 1B depicts the direct effect of CD on VA (path c') and the indirect effects of CD on VA via the mediator, namely EOAA (path a-b). The numeric values represent unstandardized coefficients. All the paths are statistically significant confirming the prediction that EOAA partially mediates the effect of CD on VA.

Note: $*p < 0.05$; $**p < 0.01$

Relationships between externalising-related variables and historical, including criminal history, variables are shown in table 5B. It may be seen that PCL F2 correlated with measures of criminal, including violent, offending, and with a number of measures indicating deviance and disinhibition from a young age, including separation from biological parents, juvenile offences, and younger offending, including violently.

Violent sexual offending was an exception to this general pattern, being associated with a higher PCL F1 score.

5. Which Measures of Externalizing Best Predicted Violent Antisociality?

The relationship between the key variables was further analysed using multiple linear regression, with VA as the dependent variable and CD, EOAA, PCL-F2, and UPPS as predictor variables. Multiple regression analysis (see table 6) revealed that EOAA ($\beta=0.157$), UPPS ($\beta=0.165$) and PCL-F2 ($\beta=0.478$) significantly predicted VA ($p<0.05$). Tests for multicollinearity (e.g. Menard, 1995; Myers, 1990) showed acceptable tolerance and VIF values (see Table 6), indicating that multicollinearity between the predictor variables was unlikely. This model explained a significant amount of variance observed in the relationship between EOAA and VA ($r^2=.504$, $F=18.932$, $p<0.0001$). The covariates (age at time of assessment, ADHD and cannabis use) were initially entered into the regression model individually to assess their effects on the parameters of the model. Since none of the covariates significantly predicted VA, they were excluded from the final regression model. When PCL F1 was added to the model, it was found not to significantly predict VA ($\beta= .103$, $t = 1.25$).

	CD	EOAA	PCL F1	PCL-F2	Premedit	Urgency	Sen seek	Perseverance	UPPS total	IGT
EOAA	.376**									
PCL-F1	.171	.196								
PCL-F2	.430**	.267**	.450**							
premeditation	.313**	.219*	.061	.288**						
urgency	.232*	.158	.204*	.206*	.503**					
sen seek	.208*	.262**	.355**	.283**	.253*	.283**				
Perseverance	.122	.176	.014	.140	.544**	.432**	-.172			
UPPS total	.367**	.292**	.283**	.377**	.751**	.739**	.484**	.534**		
IGT	-.092	.208*	.106	-.110	.022	-.149	.037	-.063	-.044	
VA	.399**	.374**	.405**	.653**	.333**	.275**	.204*	.214*	.441**	-.080

Table 5A: Inter-correlations between externalizing-related measures; * Correlation is significant at the 0.05 level (2-tailed). **. Correlation is significant at the 0.01 level (2-tailed).

	CD	EOAA	PCL-F1	PCL-F2	UPPS Premedit	UPPS Urgency	UPPS Sen seek	UPPS Persever	UPPS total	IGT	VA
Years apart from biological mother	.301**	.136	.139	.323**	.177	.117	-.062	.121	.143	-.017	.344**
Years apart from biological father	.346**	.149	.018	.296**	.261**	.171	-.116	.103	.164	-.183	.277**
Age at first offence	-.439**	-.218*	-.209*	-.539**	-.269**	-.098	-.143	-.118	-.285**	.055	-.559**
Age at first violent offence	-.390**	-.205*	-.329**	-.393**	-.210*	-.154	-.170	-.002	-.232*	.083	-.388**
No. Of violent sexual offences	-.075	-.089	.211*	.146	-.164	.002	-.026	-.140	-.089	-.034	.062
VSRS											
index offence	-.089	-.087	-.241*	-.195	-.280**	-.209*	-.262**	-.128	-.343**	.009	-.229*
institutional behaviour	.050	-.125	.230*	.254*	-.059	.132	.061	-.250*	.039	-.027	.284**
past record	.284**	.184	.306**	.523**	.188	.195	.127	.088	.285**	-.107	.862**
Total	.136	-.017	.175	.329**	-.075	.075	-.030	-.162	.001	-.072	.511**
Violence quantity	.080	.231**	.087	.313**	.162	.132	-.062	.175.	.151	-.246**	.554**
Adult APD	.501**	.485**	.390**	.486**	.334**	.292**	.332**	.247*	.487**	.047	.705**

Table 5B: correlations between externalizing-related measures and measures and historical variables, including criminal offending. * Correlation is significant at the 0.05 level (2-tailed). **. Correlation is significant at the 0.01 level (2-tailed).

	B	SE	β	t	Sig.	tolerance	VIF
Constant	-3.041	0.376		-8.260	<0.001		
CD	0.007	0.012	0.048	0.550	0.584	0.7	1.4
EOAA	0.079	0.037	0.176	2.123	0.036*	0.7	1.3
UPPS	0.007	0.003	0.161	1.956	0.05*	0.8	1.2
IGT	-0.002	0.003	-0.066	-0.858	0.393	0.8	1.3
PCL-F1	0.030	0.022	0.114	1.365	0.176	0.8	1.6
PCL-F2	0.136	0.022	0.515	6.111	<0.001 *	0.7	1.4

Table 6: results of the multiple regression analysis.* p significant at the 0.05 level.

6. Did Externalizing-Related Variables Moderate The Link Between EOAA and Violent Antisociality?

In the moderation analysis I tested twelve models using EOAA, PCL-F2, IGT and UPPS individually as either moderator or predictor variables to estimate their moderating effect in relation to VA (dependent variable). Results of moderation analysis (models 1-12) are presented in table 7. The amount of variance accounted for varied widely, the highest value was for model 1 ($r^2=0.471$, $F=28.4908$, $p<0.0001$) and the lowest was for model 10 ($r^2=0.1666$, $F=6.3959$, $p<0.001$). However, the interaction terms of all the models were not significant indicating that moderation effects could not be substantiated in relation to the effects of the above externalizing measures on VA.

Model	Predictor	Moderator	B	SE	T	Sig.	Sig. interaction term
Model 1	EOAA	PCL-F2	0.124	0.06	2.09	0.04*	0.54
Model 2	EOAA	IGT	-0.004	0.01	-0.41	0.69	0.80
Model 3	EOAA	UPPS	0.012	0.01	1.20	0.24	0.67
Model 4	PCL-F2	EOAA	0.004	0.15	0.03	0.98	0.55
Model 5	PCL-F2	IGT	0.002	0.02	0.15	0.89	0.86
Model 6	PCL-F2	UPPS	0.012	0.01	2.20	0.03*	0.22
Model 7	UPPS	EOAA	0.05	0.19	0.24	0.82	0.67
Model 8	UPPS	PCL-F2	0.24	0.08	3.14	<0.01*	0.22
Model 9	UPPS	IGT	-0.01	0.02	-0.69	0.49	0.59
Model 10	IGT	EOAA	0.18	0.05	4.30	<0.01*	0.80
Model 11	IGT	PCL-F2	0.18	0.02	8.30	<0.01*	0.86
Model 12	IGT	UPPS	0.02	0.01	0.55	<0.01*	0.59

Table 7: moderation models for the effect of moderating variables on VA. The numeric values represent regression parameters for the effect of moderator variables on dependent variable. * significance level at 0.05. **p values for the interaction terms of the focal predictor and the moderator.

7. Did Externalizing-Related Variables Mediate The Link Between EOAA and Violent Antisociality?

Mediation analysis was done in two stages. The first stage involved testing four multiple mediation models using EOAA, PCL-F2, IGT and UPPS interchangeably as independent variables or mediator variables and VA as outcome variable. The four models are presented in table 8. As may be seen, model 1 provides the best fit for explaining the relationship between these variables and indicated that both PCL-F2 and UPPS significantly mediated the effect of EOAA on VA. Therefore, this model was used to inform the second and final stage of mediation analysis after excluding IGT which persistently failed to show any effects in the mediation analysis.

Results of the final multiple mediation model (Preacher & Hayes, 2008) indicated that both PCL-F2 and UPPS significantly mediated the effect of EOAA on VA (Sobel's $Z=2.5558$ and 1.8771 respectively, p values < 0.05 ; see also Table 8). Covariates including age at time of assessment, ADHD and cannabis use were entered individually into the model to assess their effects on dependent variable. Since all of them failed to show significant effects, they were excluded from the final model (see figure 5). The final model explained a significant amount of the variance in the relationship between EOAA and VA ($r^2=0.4979$, $F=31.7369$, $p<0.0001$).

Model	IV	Mediators	Effect of IV on mediator (a)	Effect of mediator on DV (b)	Indirect effect (ab path)	Direct effect (c-prime path)	Total effect (c path)	Mediation type
Model 1	EOAA	PCL-F2	0.450**	0.139**	0.081*	0.085**	0.167**	Partial
		UPPS	3.138**	0.007*	0.024*			Partial
		IGT	2.460*	-0.002	-0.005			None
Model 2	PCL-F2	EOAA	0.158**	0.084*	0.135	0.139**	0.172**	None
		UPPS	2.397**	0.007*	0.018*			Partial
		IGT	-0.766	-0.002	-0.002			None
Model 3	UPPS	EOAA	0.027**	0.085*	0.023			None
		PCL-F2	0.059**	0.139**	0.083**	0.007*	0.018**	Partial
		IGT	-0.048	-0.002	0.001			None
Model 4	IGT	EOAA	0.017*	0.085*	0.001	-0.002	-0.003	None
		PCL-F2	-0.015	0.139**	-0.002			None
		UPPS	-0.040	0.007*	-0.003			None

Table 8: multiple mediation models of the effects of externalizing measures (EOAA, IGT, PCL F2, UPPS), using VA as dependent variable. The numeric values represent unstandardized coefficients. * significance level at <0.05, ** significance level at <0.01.

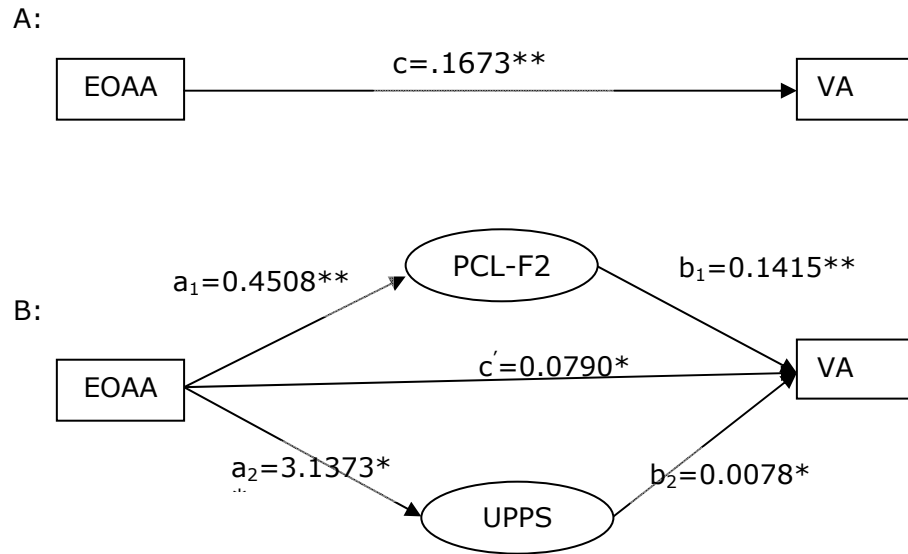

Figure 5: Multiple Mediation Model 2 (after Preacher & Hayes, 2008): Figure 4A shows the total effect of EOAA (independent variable) on VA (dependent variable) - path c . Figure 4B depicts the direct effect of EOAA on VA (path c') and the indirect effects of EOAA on VA via the mediators: namely PCL-F2 (path a_1 b_1) and UPPS (path a_2 b_2). The numeric values represent unstandardized coefficients. All the paths are statistically significant confirming the prediction that PCL-F2 and UPPS partially mediate the effect of EOAA on VA. *, P significant at 0.05; **, P significant at 0.01.

CHAPTER FIVE

DISCUSSION AND CONCLUSIONS

A. Discussion

This study sought to clarify the nature of the link between childhood conduct disorder, early onset alcohol abuse, a number of other externalizing related behaviours and adult antisocial behaviours including violence. The first question addressed in this study was: does early onset alcohol abuse mediate the link between CD and violent antisociality? Results of this study extend those of a previous study which showed that early onset alcohol abuse partially mediates the link between childhood CD and adult antisociality (Howard et al., in press). The second question addressed in this study was: which of several externalizing-related variables best accounts for the relationship between early onset alcohol abuse and violent antisociality in adulthood? Results were generally consistent with predictions arising from the hypothesis that the link between EOAA and VA is mediated by externalizing related variables such as impulsiveness and the chronically unstable and antisocial lifestyle factor of psychopathy (PCL-R F2). However, contrary to the prediction arising from the hypothesis, the study did not substantiate the effects of vm-PFC dysfunction (as measured using the IGT) on the relationship between EOAA and violent antisociality.

However, in interpreting the results of this study it should be noted that the study suffered several limitations (e.g. see section B of this chapter) and a number of others issues have to be taken into consideration as described below.

1. Sample Characteristics

As can be seen from the results, co-morbidity with DSM-IV axes I and II disorders was common among participants of the study. For instance, as noted earlier, the mean number of personality disorder diagnoses was 2.9. A large proportion received co-morbid lifetime diagnoses of major depression and alcohol abuse/dependence (56% and 58% respectively). A quarter received a diagnosis of childhood ADHD. Over a half were in receipt of psychotropic medications at the time of assessment including antipsychotics, antidepressants, and others such as benzodiazepines. Additionally, life time history of regular and/or daily use of illicit drugs was very common among the participants; cannabis was the most commonly abused illicit drug, followed next by stimulants, opiates, and hallucinogens.

While this complex array of psychopathology is not surprising to clinicians who work with personality disordered offenders detained in secure settings, its presence makes it difficult for the researcher to disentangle the effects of various competing variables on the outcome of interest - adult antisocial behaviour in this case. In an attempt to tease apart the effects of site and admission criteria, I initially conducted comparisons by site and by admission criteria (i.e. PD v DSPD group) to assess whether participants across the sites (Arnold Lodge, Broadmoor and Rampton hospitals) and within admission categories differed in terms of demographics, criminal history, personality, and clinical characteristics.

2. Comparisons By Site

Results of comparison by site revealed that groups were similar in terms of IQ, age at index offence, socio-demographics (except for age

at the time of assessment), the use of illicit drugs, the use of prescribed psychotropic medications, personality disorder profile, personality disorder severity, PCL-R scores and adult antisocial personality disorder dimensional scores. However, there were some notable exceptions. For instance, residents of medium security were younger at the time of assessment and scored higher on measures of impulsivity and EOAA than those of high security hospitals. In addition, they had a significantly greater prevalence of ADHD and lifetime alcohol abuse/dependence. In contrast, Rampton participants showed a greater prevalence of depression and conduct disorder and scored higher on the violence rating scale than the rest.

While these differences (which are largely consistent with clinical observations) may represent true differences, it should be born in mind they may be related to differences in admission criteria or practices across the sites. For instance, the treatment programme at Arnold Lodge is usually but not invariably offered to sentenced prisoners and for a predefined period of time (18 – 24 months), following which they are remitted back to prison. The majority of these patients are young and impulsive and have poor social skills. In contrast, patients in high security are usually admitted on a hospital order and the average length of stay in high security is about 8 years (Badger et al, 1998). It is therefore not surprising that the population of high security is relatively older than medium security. They may also be more settled given the length of their incarceration in hospital.

3. Did Patients Admitted To DSPD Units Represent A Distinct Group?

DSPD patients were similar to their PD counterparts in terms of demographics, criminal history, personality, and clinical characteristics,

with a few notable exceptions. The most obvious was that the DSPD group scored higher on PCL-R. This difference in the PCL-R scores is not surprising given that it forms an essential element of the criteria for DSPD. Nonetheless, DSPD group emerged as no more antisocial than their PD counterparts.

In terms of personality characteristics DSPD patients scored significantly lower on Cluster C (anxious and avoidant) traits. This confirms the low prevalence of Cluster C PDs (around 10%) reported by Kirkpatrick, Draycott, Freestone, Cooper, Twiselton, Watson, Evans, et al (2010) in DSPD patients and is consistent with their greater psychopathy which classically (e.g. Cleckley, 1941) is associated with a low prevalence of neurotic traits. While there was no significant relationship between group and Axis-I co-morbidity for any given C-DIS diagnosis, nonetheless it is evident from Table 3 that there was a tendency for the DSPD group to show overall less Axis-I co-morbidity, e.g. major depression, and not to be on prescribed psychotropic medication. This again is consistent with their higher PCL psychopathy, which has previously been reported to be inversely related to depression in mentally disordered offenders (Stålenheim and Von Knorring, 1996).

4. Did Patients With EOAA History Differ From Those Without Such A History On Externalizing-Related Variables?

Analysis based on grouping patients according to their history of alcohol abuse showed that those patients with a history of early onset alcohol abuse, in comparison with those without such a history, scored higher on a range of externalizing-related variables: they were more impulsive, scored higher on the social deviance factor of psychopathy,

were more conduct disordered, and showed a higher level of VA. The late onset group did not score significantly higher than the nil history group on these variables. The results of this study are consistent with findings that individuals with personality disorder and co-occurring alcohol dependence have higher rates of illicit substance use disorders (Galen, Brower, Gillespie & Zucker, 2000) and PCL-R psychopathy (Walter, Wiesbeck, Dittmann, Graf, 2011). These results are also consistent with the proposal that EOAA may play a critical role in the aetiology of serious antisociality in adulthood (Howard, 2006; Howard, 2009), and with previous research reviewed by Lejuez et al (2010) showing that alcohol use, and particularly early onset of drinking, is associated with increased impulsiveness.

5. Did EOAA Mediate The Effects Of CD On Violent Antisociality?

CD and EOAA were significantly and positively correlated, confirming findings that those with a history of CD are more likely to engage in early-onset abuse of alcohol (e.g. Gustavson et al., 2007; Buchmann et al., 2010), or vice versa, and suggesting a reciprocal relationship between CD and adolescent substance use (Loeber et al., 2000). Further regression analysis demonstrated that both CD and EOAA independently predicted the antisocial outcome. Moreover, the effect of CD on VA was significantly mediated by EOAA, even when covariates (including age, cannabis use and ADHD) were partialled out. This suggests that the resulting violent antisociality could be partially predicted by individuals who initially displayed CD in childhood and adolescence and subsequently engaged in alcohol abuse before the age of 20.

Nonetheless, CD and substance use likely act reciprocally with each other, so that by late adolescence alcohol abuse becomes woven into the fabric of disordered conduct (Loeber et al., 2000). The finding that EOAA mediates the effect of CD on violent antisociality replicates the finding obtained in an American community sample (Howard et al., 2011) and is consistent with previous findings: first, that younger age of onset of substance (including alcohol) abuse predicted violent recidivism, CD, and life-time aggression (Gustavson et al., 2007); and second, that early alcohol abuse is a significant risk factor for life-course persistent antisocial behaviour (Farrington et al., 2009). Taken together, these findings are consistent with the hypothesis that early-onset alcohol abuse acts as a critical variable in mediating the relationship between disinhibitory childhood psychopathology and adult antisociality (Howard, 2006; 2009).

One notable difference between the current findings and those obtained in the Howard et al. (2011) study is that EOAA was previously found to significantly moderate (i.e. exacerbate) the effect of CD on adult antisocial behaviour. In that study, the effect of EOAA was greatest in those who scored highest on CD, and was minimal in those who scored lowest on CD. In contrast, we could find no evidence in this forensic sample that EOAA significantly moderated the effect of CD on VA. This discrepancy is likely attributable to differences in the composition of the two samples. In contrast with the previously studied community sample comprising males and females, the current forensic sample were highly deviant offenders, all males, most with a history of serious and often violent offending. All had confirmed personality disorders, often severe and with a high level of PD co-morbidity as well as co-morbidity with DSM Axis I disorders (particularly depressive disorders). Importantly,

over three-quarters of the sample showed a history of CD. This high prevalence of CD in the sample meant that the range of CD scores was restricted, with very few showing absent or low levels of CD symptoms. This restricted range of CD scores would have limited the possibility of finding an interaction between EOAA and CD.

In sum, the results confirm previous findings by Howard et al. (2011) in suggesting that, by partially mediating the effects of childhood CD, early-onset alcohol abuse may play a critical role in the aetiology of adult antisocial behaviour.

6. Which of Several Externalizing-Related Variables Best Accounts For The Relationship Between EOAA and VA In Adulthood?

Inspection of its correlates (see Table 5A and B) suggests that EOAA is part of a pattern of early deviance, e.g. early-onset, including violent, offending, that persists throughout adolescence and into adulthood, where it is manifested as VA. This pattern is characteristic of the male life-course persistent offender, described by Moffitt et al (2002) as showing weak bonds to family, early school leaving, psychopathic traits of alienation, impulsiveness and callousness, and violent criminality. Of those among males in the birth cohort studied by Moffitt and colleagues who subsequently became life-course persistent (LCP) offenders, almost half were alcohol dependent by age 18 (see Howard, 2006). Results from another New Zealand longitudinal study similarly showed that adolescence-onset alcohol abuse predicted violent offending both in late adolescence (age 15-21) and in early adulthood (age 21-25), even after confounding background and individual factors, including CD, were controlled (Wells, Horwood & Fergusson, 2004).

With the exception of measures of early institutionalisation, which correlated significantly with CD but not with EOAA, the pattern of correlations for EOAA and CD matched each other closely (see Table 5A and B). CD and EOAA also correlated significantly with each other, consistent both with the observation that they commonly co-occur in adolescence (DeBrito & Hodgins, 2009) and with the finding in the current study that, in the grouped data, patients with EOAA showed the highest CD dimensional score. Nonetheless, results of the second regression analysis (see Table 6) indicated that EOAA, but not CD, significantly predicted VA. The failure of CD to predict VA may in part reflect the fact that in the regression analysis, the variance in VA attributable to childhood and adolescent deviance was primarily captured by PCL-F2. Nonetheless EOAA emerged, together with impulsiveness and PCL-R Factor 2, as significant and independent predictors of VA. Of these, PCL-R Factor 2 emerged as the strongest predictor. In contrast, PCL-R Factor 1 failed to predict VA, suggesting that the core personality features emphasised in Cleckley's (1941) description of the prototypical "psychopath" are not in general associated with VA.

These results are, moreover, consistent with those of the most recent and methodologically rigorous meta-analysis showing that Factor 2, but not Factor 1, predicted violence in males (Yang et al., 2010). Despite the modest and significant (with the exception of lack of perseverance) correlations seen between UPPS measures and PCL F2, its significant correlates included indicators of early deviance, including younger age of offending (particularly violent offending) and longer periods of early institutionalisation. This suggests that PCL-R F2 is tapping deviance and disinhibition from a young age, which would be consistent with

evidence of a positive association between psychopathy (particularly PCL-R Factor 2) and inadequate or dysfunctional early experiences (Hare, 2003).

Despite its failure to predict VA, two notable correlates of FCL-R F1 emerged from this study: excitement seeking (UPPS sensation seeking) and sexual violence. Some have argued that excitement seeking is an important motivation for some types of violence (e.g. Howard, in press); it is possible therefore that excitement seeking is an important motivation for the sexual violence shown by those with the interpersonal and affective traits of psychopathy.

Moderation analysis failed to substantiate any moderating effects for externalizing related variables in relation to antisocial outcomes. This could be related to the fact that externalizing related psychopathology was highly prevalent in the sample, indicating that a larger sample was needed to detect small effects such as moderation.

Further analysis using the multiple mediation model of Preacher & Hayes (2008) showed that, in a model explaining almost 50% of the variance in VA, the latter's relationship with EOAA was mediated significantly and independently by both impulsiveness and PCL Factor 2 (see Figure 4). This finding is consistent with Jolliffe & Farrington's (2009) conclusion, after systematically reviewing the evidence, that childhood impulsiveness predicts later violence, but suggests that impulsiveness leading to adult violence results, at least in part, from early alcohol abuse. It also concurs with the hypothesis that, in the context of disinhibitory childhood psychopathology, early alcohol abuse results in increasing neural and behavioural disinhibition, leading in

turn to an escalating pattern of alcohol use and brain dysfunction (Howard, 2006; 2009). Patrick and colleagues have similarly suggested that deficits in self-regulation in high-externalising individuals arise from impaired function of higher brain systems that operate to guide and inhibit behaviour and regulate emotional responses (Patrick & Bernat, 2006; 2009). While Patrick and colleagues' hypothesis is entirely consistent with Howard's (2006) hypothesis, the latter additionally specifies a putative causal pathway leading from CD to VA through EOAA and impulsiveness.

While evidence suggests that adolescent alcohol abuse results in structural changes in the brain (De Bellis, Narasimhan, Thatcher, Kashavan, Soloff & Clark, 2005; De Bellis et al., 2008), contrary to the prediction arising from the hypothesis vm-PFC dysfunction (as indexed by IGT performance), failed to show any effects on the relationship between EOAA and adult antisocial outcomes. It is notable that although the median absolute score (the difference between the number of advantageous and disadvantageous cards selected by participants) for the whole sample indicated impairment of vm-PFC functioning (median=-2), the range was very wide (-60, 80), indicating that a larger sample was required in order to better approximate normality of distribution and to differentiate groups. Further, while performance deficits on IGT can differentiate individuals who have deficits in vm-PFC functioning (Bechara, 2007), the specificity and reliability of IGT in clinical populations has been questioned by some authors (e.g. see Dunn, Dalgleish & Lawrence, 2006). Dunn et al (2006) argue that the majority of psychiatric patients show performance deficits on IGT casting doubts on whether these deficits are specific to particular psychiatric or neurological conditions. Also, it

is worth noting that performance deficits on IGT and other tests of executive functioning can also be affected by impulsivity, level of education, IQ below certain thresholds, psychotropic medication use and illicit substance misuse which was highly prevalent in this study (Dunn, et al, 2006; Bechara et al, 2001).

Although the groups defined by presence versus absence of EOAA did not differ on IGT performance, when the IGT Net scores by subsets (5 sets of 20 cards) were plotted, the EOAA group performed less well than the nil history and LOAA groups (see figure 3). Although results were not statistically significant, this may indicate that while offenders with personality disorder may show disadvantageous IGT performance, history of early onset alcohol abuse does not have any added effects on IGT performance deficits. They may also confirm the previous finding that IGT performance deficits in the context of substance misuse apply only to a subgroup of patients with substance misuse disorder. For instance, Bechara, Dolan, Denburg, Hindes, Anderson & Nathan (2001) assessed IGT performance in three groups of subjects; substance dependents (n=41); patients with vm-PFC lesions (n=5) and control subjects (n=40). The results showed that over 60% of substance dependents and about a third of control subjects had IGT Net scores below 10 cards (within the range of vm-PFC patients). Correlation analysis showed non-significant correlations between IGT performance and age, level of education, IQ, PCL-R scores, measures of depression and anxiety as well as executive function as indexed by the Wisconsin Card Sorting test, Stroop test and Tower of Hanoi. However, a closer inspection of the data revealed that performance of the substance dependent group was not uniform with a group performing as well as controls.

In short, although overall performance on IGT was impaired for the sample as a whole, IGT performance deficits failed to differentiate individuals with a history of early onset alcohol abuse and to show any effects on the relationship between EOAA and violent antisociality. It must be noted that neurobiological studies of the relation between adult antisocial behaviour and frontal lobe deficits yielded mixed results (Morgan & Lilienfeld, 2000; Wahlund, 2009; Dolan & Park, 2002) with some studies showing impairment of orbitofrontal cortex (e.g. Goyer, Andreason, Semple, Clayton, King, Compton-Toth, et al., 1994; Kuruoglu, Arikan, Vural, Karatas, Arac, & Isik, 1996) and others failing to show differences between antisocial individuals and healthy controls (e.g. Dolan, Deakin, Roberts & Anderson, 2002). Unfortunately, the fact that neurobiological studies in this area are plagued by methodological limitations including small sample sizes, difficulty with subject selection and difficulty with controlling for the effect of substance misuse has made it difficult for researchers to draw definitive conclusions (Wahlund, 2009; Dolan, 2002).

The direct effect of CD on VA implies the existence of other mechanisms whose role is independent of impulsivity and early-onset alcohol abuse. One such mechanism is a pre-existing neurophysiological abnormality linked to emotional processing in CD children. For example, children with both early- and late-onset conduct problems have been reported to show reduced neural activation to emotional stimuli in frontal brain structures previously linked to antisocial behaviour (Passamonti, Fairchild, Goodyer, Hurford et al., 2010). Other mechanisms may include a series of complex interactions between psychosocial adversity and biological factors (Raine, 2002). It

could also be related emotional dysregulation brought about by deficits in the neural circuitry of emotion regulation (Davidson, Putnam & Larson, 2000).

B. Limitations

Several caveats should be born in mind when interpreting the results of this study. First, this is a cross sectional study, limiting the ability to infer the direction of causality. A longitudinal design is required to demonstrate a causal link between EOAA and violence (if any) in individuals with PD, although it is worth noting that while positive the results of this study may be suggestive of a causal link, negative findings would have disproved the hypothesis all together. Second, this was a relatively small-sized sample of men, limiting the generalizability of our findings to women with PD and pointing to the need for replication in a larger sample. Another possible effect of the small sample size is that certain effects, such as moderation, could not be detected or substantiated. Third, the study was cross-sectional and assessment of symptoms was retrospective, and therefore relied on interviewees being truthful in their responses and accurate in their recollections. This applies particularly to assessment of patients' age of onset of alcohol abuse history and their CD symptoms. It has previously been noted that self-report can result in both false-positive and false-negative errors, particularly for recalled childhood behaviours (Rueter, Chao & Conger, 2000). Further, assessment of violence relied partly on file review and Police National Computer (PNC) record. Although PNC was available for most patients, in some cases this was missing. Consequently, assessment of violence relied entirely on clinical records and self report. Further, measurement of violence was rather crude and didn't differentiate different types of violence. This is important as different forms of violence may have different motives, for example, excitement seeking versus

reactive-expressive, or instrumental/coercive versus vindictive/vengeful. Fourth, the study was conducted on a sample of incarcerated offenders who may have a vested interest in downplaying psychopathology and violent tendencies. Therefore, it is entirely possible that the effects detected in this study were an underestimate of the true effects, especially in relation to violent outcomes. Conversely, the effects of alcohol in relation to antisocial outcomes may represent an overestimate of the true effects since it is well established that people may boast about their drinking and drug taking habit by giving exaggerated accounts. Fifth, it should be noted illicit drug misuse was highly prevalent among participants. While this is not surprising, it raises the strong possibility that alcohol acts in synergy with illicit drugs in mediating the link between CD and adult antisociality. Howard's (2006) hypothesis should take this into account this possibility. Sixth, perhaps a major limitation of this study is that it didn't measure the effects of psychosocial adversity in relation to antisociality. Also, executive functioning should have been more thoroughly assessed. Given the functional and structural heterogeneity of PFC, more extensive measures of frontal lobe function would have been necessary to test the frontal brain part of the hypothesis.

Finally, this hypothesis suggests that impulsivity and early alcohol use mutually potentiate each other: a high level of impulsivity, already present as part of the CD syndrome, leads to early and accelerating use of alcohol and other drugs, which in turn, via effects on frontal brain regions, leads to greater impulsivity and hence greater alcohol abuse. Ultimately, the relationship between CD and substance use is likely reciprocal, with each exacerbating the expression of the other (Loeber, Burke, Lahey et al. (2000), so that alcohol and other drug abuse becomes woven into the fabric of disordered conduct. Longitudinal studies, rather than the cross-

sectional design used here, will be required to verify this part of the hypothesis.

C. Summary and Conclusions

The current study addressed the questions of whether EOAA mediated the link between CD and VA and whether the effects of EOAA were mediated by impulsiveness, vm-PFC dysfunction and psychopathy. Results showed that EOAA mediated the link between CD and VA, even after partialling out the effects of age, cannabis misuse and ADHD. Also, that PCL-R F2 and impulsiveness significantly mediated the effect of EOAA on VA. However, contrary to the prediction arising from the hypothesis, the effects of vm-PFC dysfunction on violent antisociality were insignificant. Although the study suffered from some limitations, results suggest that both impulsiveness and social deviance contribute importantly to a pathway leading from CD through adolescent alcohol abuse to maladaptive personality development and adult VA. Further, results of this study highlight the importance of considering excessive alcohol consumption in the aetiology of adult antisocial behaviour and as an important contributory factor in the phenotypic expression of externalizing in adulthood

D. Implications

Results of this study have two important implications. First, in order to prevent CD from translating into adult antisocial outcomes, conduct disordered children should be particularly targeted for interventions aimed at preventing them from using alcohol, and possibly illicit drugs, to excess. A second implication is that since early-onset alcohol abuse is both common among antisocial populations (Gustavson et al., 2007; Bakken et al., 2004), and is associated with structural brain changes (DeBellis et al,

2005; 2008), findings of brain abnormalities in antisocial samples should be interpreted cautiously. Such brain abnormalities should only be interpreted as correlates of antisocial behaviour after due consideration has been given to the possibility that they may have arisen as a result of adolescent alcohol and other drug abuse. Indeed, we would argue that such substance abuse and its neurological consequences are an important part of the aetiology of adult antisocial behaviour.

E. Directions For Future Research

Findings of this study will need to be replicated in future studies which will also need to demonstrate that frontal lobe changes are causally related to deficits in emotional and behavioural self-regulation and to subsequent adult antisocial behaviour. Studies using a longitudinal design will be needed to explore in detail how, during adolescence, impulsiveness and early alcohol abuse interact to produce deficits in the neural substrates of emotional and behavioural self-regulation. Lejuez et al. (2010) highlight the importance of considering the bi-directional nature of the relationship between impulsiveness and alcohol use, as suggested in Howard's (2006) hypothesis, and of conducting longitudinal studies to clearly differentiate the causes from the consequences of excessive alcohol use. Results of the current study point to the need to consider abuse of substance other than alcohol, particularly cannabis, since two-thirds of the current sample as a whole, and more than half of those who abused alcohol before age 20, had used cannabis on a regular or daily basis. There is likely to be a synergy between alcohol and cannabis in their detrimental effects on the development of brain and personality.

The hypothesis also needs to be broadened to take account of findings suggesting that exposure to alcohol at an earlier developmental stage can

exert detrimental effects that predispose to disordered conduct in childhood, e.g. through a binge pattern of maternal alcohol consumption (Sayal, Heron, Golding, Alati et al., 2010). Clearly, the factors posited in this hypothesis are but a small part of a much larger picture. Violence may result from a complex interaction between various psychosocial, biological, situational and victim related factors. Future studies need to assess how these factors interact in relation to violent behaviour.

REFERENCES

1. Amen, D.G., Stubblefield, M., Carmicheal, B., Thisted, R. (1996). Brain SPECT findings and aggressiveness. *Annals of Clinical Psychiatry*, 8,129-137.
2. American Psychiatric Association. (1994). *Diagnostic and Statistical Manual of Mental Disorders, 4th edition*. Washington DC: APA.
3. Anestis, M.D., Anestis, J.C. & Joiner, T.E. (2009). Affective considerations in antisocial behavior: an examination of negative urgency in primary and secondary psychopathy. *Personality and Individual Differences* 47: 668-670.
4. Badger, D., Nursten, J., Williams, P. & Woodward, M. (1999). *Systematic review of the international literature on the epidemiology of mentally disordered offenders*. York: NHS Centre for Reviews and Dissemination.
5. Bakken, K., Landheim, A. S., & Vaglum, P. (2004). Early and late onset groups of substance misusers: Differences in primary and secondary psychiatric disorders. *Journal of Substance Use*, 9, 224-234.
6. Baron, R. M., & Kenny, D. A. (1986). The moderator–mediator variable distinction in social psychological research: Conceptual, strategic, and statistical considerations. *Journal of Personality & Social Psychology*, 51, 1173-1182.
7. Bauer L. O., & Hesselbrock, V. M. (1999a). P300 decrements in teenagers with conduct problems: Implications for substance abuse risk and brain development. *Biological Psychiatry*, 46, 263–272.
8. Beach, S. R. H., Brody, G. H., Gunter, T. D., Packer, H., Wernett, P., & Philibert, R. (2010). Child maltreatment moderates the association of MAOA with symptoms of depression and antisocial personality disorder. *Journal of Family Psychology*, 24 (1), 12-20.

9. Bechara, A. (2007). *Iowa Gambling Task*. Psychological Assessment Resources, Inc. USA.
10. Bechara, A., Damasio, A.R., Damasio, H. & Anderson, S.W. (1994). Insensitivity to future consequences following damage to human prefrontal cortex. *Cognition*, 50, 7-15.
11. Bechara, A., Dolan, S. L., Denburg, N. L., Hinds, A., Anderson, S. W., & Nathan, P. E. (2001). Decision making deficits, linked to a dysfunctional orbitofrontal cortex, revealed in alcohol and stimulant abusers. *Neuropsychologia*, 39, 376-389.
12. Becker, D.F., Grilo, C.M., Edell, W.S., & McGlashan, T.H. (2002). Diagnostic efficiency of borderline personality disorder criteria in hospitalized adolescents: comparison with hospitalized adults. *American Journal of Psychiatry* 159, 2042-2047.
13. Bernstein, D. P., Cohen, P., Skodol, A., Bezirgianian, S. & Brook, J. S. (1996). Childhood antecedents of adolescent personality disorders. *American Journal of Psychiatry*, 153, 907-913.
14. Black, D.W. & Braun D. (1998). Antisocial patients: a comparison of those with and those without childhood conduct disorder. *Annals of Clinical Psychiatry*, 10, 53-57.
15. Black, D.W., Baumgard, C.H., Bell, S.E., & Kao, C. (1996). Death rates in 71 men with antisocial personality disorder: A comparison with general population mortality, *Psychosomatics*, 37(2), 131-136.
16. Blackburn, R. (1988). On moral judgements and personality disorders: The myth of psychopathic personality disorder revisited. *British Journal of Psychiatry*, 153, 505-512.
17. Blackburn, R. (2007). Personality disorder and antisocial deviance: comments on the debate on the structure of the Psychopathy Checklist-Revised. *Journal of Personality Disorders*, 21, 142-159.

18. Blake, P. Y., Pincus, J. H., & Buckner, C. (1995). Neurologic abnormalities in murderers. *Neurology*, 45, 1641-1647.
19. Brems, C., Johnson, M.E., Neal, D., and Freemon, M. (2004). Childhood abuse history and substance use among men and women receiving detoxification services. *The American Journal of Drug and Alcohol Abuse*, 30 (4), 799-821.
20. Brennan, P. A., Mednick, B. R., & Mednick, S. A. (1993). Parental psychopathology, congenital factors, and violence. In S. Hodgins (Ed.) *Mental Disorder and Crime* (pp.244-261). Newbury Park, CA: Sage.
21. Brennan, P. A., Raine, A., Schulsinger, F., Kirkegaard-Sorensen, L., Knop, J., Hutchings, B., et al. (1997). Psychophysiological protective factors for male subjects at high risk for criminal behavior. *American Journal of Psychiatry*, 154, 853-855.
22. Buchmann, A.F., Schmid, B., Blomeyer, D., Becker, K., Treutlein, J., Zimmermann, U.S., Jennen-Steinmetz, C., Schimdt, M.H., Asser, G., Banaschewski, T., Rietschel, M., Schumann, G. & Laucht, M. (2009). Impact of age at first drink on vulnerability to alcohol-related problems: Testing the marker hypothesis in a prospective study of young adults. *Journal of Psychiatric Research*, 43 (15), 1205- 1212.
23. Burke, J. D., Loeber, R., & Mirmaher, B. (2002). Oppositional defiant disorder and conduct disorder: A review of the past 10 years, Part II. *Journal of the American Academy of Child and Adolescent Psychiatry*, 41 (11), 1275-1293.
24. Burke, J. D., Waldman, I. & Lahey, B. B. (2010). Predictive validity of childhood oppositional disorder and conduct disorder: implications for the DSM-V. *Journal of Abnormal Psychology*, 119, 739-51.

25. Burt, S. A., & Mikolajewski, A. J. (2008). Preliminary evidence that specific candidate genes are associated with adolescent-onset antisocial behaviour. *Aggressive Behavior, 34*, 437-445.
26. Caspi, A. (2000). The child is father of the man: personality continuities from childhood to adulthood. *Journal of Personality and Social Psychology, 78*, 158-172.
27. Caspi, A., McClay, J., Moffitt, T. E., Mill, J., Martin, J., Taylor, A. & Poulton, R. (2002). Role of genotype in the cycle of violence in maltreated children. *Science, 297*, 851-854.
28. Caspi, A., Langley, K., Milne, B., Moffitt, T. E., O'Donovan, M., Owen, M. J., Polo Tomas, M., Poulton, R., Rutter, R., Taylor, A., Williams, B., & Thapar, A. (2008). A replicated molecular genetic basis for subtyping antisocial Behavior in children with attention-deficit/hyperactivity disorder. *Archives of General Psychiatry, 65*(2), 203-210.
29. Cleckley, H (1941). *The Mask of Sanity*. Oxford, England: Mosby.
30. Coid, J. W., & Ullrich, S. (2010). Antisocial personality disorder is on a continuum with psychopathy. *Comprehensive Psychiatry, 51*(4), 426-433.
31. Coid, J., Kahtan, N., Gault, S., Cook, A., & Jarman, B. (1999). Medium secure forensic psychiatry services: comparison of seven English health regions. *British Journal of Psychiatry, 178*, 55-61.
32. Coid, J., Yang, M., Roberts, A., Ullrich, S., Moran, P., Bebbington, P., Brugha, T., Jenkins, R., Farrell, M., Lewis, G., & Singleton, N. (2006a). Violence and psychiatric morbidity in the national household population of Britain: public health implications. *British Journal of Psychiatry, 189*, 12-19.
33. Coid, J., Yang, M., Roberts, A., Ullrich, S., Moran, P., Bebbington, P., Brugha, T., Jenkins, R., Farrell, M., Lewis, G., & Singleton, N.

- (2006b). Violence and psychiatric morbidity in a national household population: A report from the British household survey. *American Journal of Epidemiology*, 164, 1199-1208.
34. Coid, J., Hickey, N., Kahtan, N., Zhang, T., & Yang, M. (2007). Patients discharged from medium secure forensic psychiatry services: reconvictions and risk factors. *British Journal of Psychiatry*, 190, 223-229.
35. Coid, J., Yang, M., Ullrich, S., Zhang, T., Roberts, A., Roberts, C., Rogers, R., Farrington, D. (2007). *Predicting and understanding risk of re-offending: the Prisoner Cohort Study*. London, The Ministry of Justice.
36. Coid, J., Moran, P., Bebbington, P., Brugha, T., Jenkins, R., Farrell, M., Lewis, G. & Singleton, N. (2009). The co-morbidity of personality disorder and clinical syndromes in prisoners. *Criminal Behaviour and Mental Health*, 19, 321-333.
37. Cooke, D.J. (1995). Psychopathic disturbance in the Scottish prison population: The cross-cultural generalisability of the Hare Psychopathy Checklist. *Psychology, Crime and Law*, 2, 101-108.
38. Cooke, D. J., & Michie, C. (2001). Refining the construct of psychopathy: Towards a hierarchical model. *Psychological Assessment*, 13, 171-188.
39. Cooke, D.J., Michie, C., & Skeem, J. (2007). Understanding the structure of the Psychopathy Checklist – Revised. *British Journal of Psychiatry*, 190 (suppl. 49), s39-s50.
40. Corrigan, F., Gray, R., Strathdee, A., Skinner, R., Van Rhijn, A., & Horrobin, D. (1994). Fatty acid analysis of blood from violent offenders. *Journal of Forensic Psychiatry*, 5, 83-92.
41. Cunnane, S. C. (1988). *Zinc: clinical and biochemical significance*. Boca raton, FL; CRC Press, Inc.

42. Cyders, M. A., Smith, G. T., Spillane, N. S., Fischer, S., & Annus, A. M. (2007). Integration of impulsivity and positive mood to predict risky behavior: Development and validation of a measure of positive urgency. *Psychological Assessment, 19*, 107-118.
43. Damasio, H., Grabowski, T., Frank, R., Galaburda, A.M., Damasio, A.R.(1994). The return of Phineas Gage: clues about the brain from a skull of a famous patient. *Science, 264*, 1102-1105.
44. Dascalu, M., Compton, W.M., Horton, J.C., & Cottler, L.B. (2001). Validity of DIS-IV in diagnosing depression and other psychiatric disorders among substance users. *Drug and Alcohol Dependence, 63*, 37.
45. Davidson, R. J., Putnam, K. M., & Larson, C. L. (2000). Dysfunction in the neural circuitry of emotion regulation-A possible prelude to violence. *Science, 289*, 591-594.
46. Davies, S., Clarke, M., Hollin, C., & Duggan, C. (2007). Long-term outcomes after discharge from medium secure care: a cause for concern. *British Journal of Psychiatry, 191*, 70-74.
47. D'Silva, K., Duggan, C., McCarthy, L. (2004). Does treatment really make psychopaths worse? A review of the evidence. *Journal of Personality Disorders, 18* (2), 163-177.
48. De Bellis, M. O., Narasimhan, A., Thatcher, D. L., Kashavan, M. S., Soloff, P & Clark, D. B. (2005). Prefrontal cortex, thalamus, and cerebellar volumes in adolescents and young adults with adolescent-onset alcohol use disorders and comorbid mental disorders. *Alcoholism: Clinical and Experimental Research, 29* (9), 1590-1600.
49. De Bellis, M. D., Van Voorhees, E., Hooper, S. R., Gibler, N., Nelson, L., Hege, S. G., Payne, M. E., & MacFall, J. (2008). Diffusion tensor measures of the corpus callosum in adolescents with

- adolescent onset alcohol use disorders. *Alcohol: Clinical & Experimental Research*, 32, 395–404.
50. DeBrito, S. A. & Hodgins, S. (2009). Antisocial personality disorder. In McMurrin, M. & Howard, R.C. (eds). *Personality, personality disorder and violence*, pp.133-153. Chichester: John Wiley & Sons Ltd.
51. Department of Health and Home Office. (1999). *Managing dangerous people with severe personality disorder*. London: Department of Health.
52. Department of Health. (2004). *National Health Act 1977: Primary Care Trust medical Services (No. 2): Directions 2004*.
53. Dolan, M. C. (1994). Psychopathy - a neurobiological perspective. *British Journal of Psychiatry*, 165, 151-159.
54. Dolan, M. (2002). What neuroimaging tells us about psychopathic disorders. *Hospital Medicine*, 63(6), 337–340.
55. Dolan, M. (2003). *Neurobiological approaches to disorders of personality*. London: National Programme on Forensic Mental Health.
56. Dolan, M., & Park, I. (2002). The neuropsychology of antisocial personality disorder. *Psychological Medicine*, 32, 417-427.
57. Dolan, M.C., Deakin, J. F. W., Roberts, N., & Anderson, I. M. (2002). Qualitative frontal and temporal structural MRI studies in personality disordered offenders and control subjects. *Psychiatry Research: Neuroimaging*, 116, 133-149.
58. Dolan, S, L., Bechara, A., Nathan, P. E. (2008). Executive dysfunction as a risk marker for substance misuse: the role of impulsive personality traits. *Behavioural Sciences and the Law*, 26, 799-822.

59. Douglas, K. S., Webster, C. D., Hart, S. D., Eaves, D., & Ogloff, J. R. P. (2001). *HCR-20: Violence risk assessment companion guide*. Mental Health, Law, and Policy Institute, Simon Fraser University, Canada.
60. Dunn, B.D., Dalgleish, T., & Lawrence, A.D. (2006). The somatic marker hypothesis: A critical evaluation. *Neuroscience and Biobehavioral Reviews*, 30, 239-271.
61. Duggan, C., & Gibbon, S. (2008). The assessment of personality disorder. *Psychiatry*, 7, 99-101.
62. Duggan, C., & Howard, R. (2009). The functional link between personality disorder and violence: A critical appraisal. In McMurrin, M., & Howard, R. (Eds.). *Personality, Personality Disorder and Violence* (pp 19-37). Chichester: John Wiley & Sons, Ltd.
63. Eaton, N.R., South, S.C. & Krueger, R.F. (2010). The meaning of comorbidity among common mental disorders. In T. Millon, R. F. Krueger, & E. Simonsen (Eds.), *Contemporary directions in psychopathology: Toward the DSM-V*, (pp.223-241). New York: Guilford Press.
64. Eme, R. (2009). Male life-course persistent antisocial behavior: A review of neurodevelopmental factors. *Aggression and Violent Behavior*, 14, 348-358.
65. Eronen, M., Hakola, P., & Tiihonen, J. (1996). Mental disorders and homicidal behaviour in Finland. *Archives of General Psychiatry*, 53, 497-501.
66. Farrington, D. P. (1995). The development of offending and antisocial behaviour from childhood: Key findings from the Cambridge Study in Delinquent Development. *Journal of Child Psychology and Psychiatry*, 36(6), 929-964.

67. Farrington, D. P. (2010). The developmental evidence base: psychosocial research. In Towl, G. J. & Crighton, D. A. (eds). *Forensic Psychology*. BPS Blackwell. Blackwell Publishing Ltd.
68. Farrington, D.P., Ttofi, M. M. & Coid, J. W. (2009). Development of adolescence-limited, late-onset, and persistent offenders from age 8 to age 48. *Aggressive Behavior*, 35, 150-163.
69. Fast, D. K., Conry, J., & Looock, C. A. (1999). Identifying Fetal Alcohol Syndrome among youth in the criminal justice system. *Journal of Developmental and Behavioral Pediatrics*, 20, 370-372.
70. Fazel, S., & Danesh, J. (2002). Serious mental disorder in 23 000 prisoners: A systematic review of 62 surveys. *The Lancet*, 359, 545-550.
71. Fellows, L. K., Farah, M. J. (2007). The Role of ventromedial prefrontal cortex in decision making: Judgment under uncertainty or judgment per se? *Cerebral Cortex*, 17 (11), 2669-2674.
72. Fergusson, D.M., Horwood, L.J., & Lynskey, M.T. (1993). Early dentine lead levels and subsequent cognitive and behavioural development. *Journal of Child Psychology and Psychiatry*, 34, 215-228.
73. Fetissov, S. O., Hallman, J., Nilsson, I., Lefvert, A. K., Orelund, L., & Hökfelt, T. (2006). Aggressive behavior linked to corticotropin-reactive autoantibodies. *Biological Psychiatry*, 60, 799-802.
74. Finn, P. R., Sharkansky, E. J., Brandt, K. M., & Turcotte, N. (2000). The effects of familial risk, personality, and expectancies on alcohol use and abuse. *Journal of Abnormal Psychology*, 109, 122-133.
75. Finn, P. R., Rickert, M. E., Miller, M. A., Lucas, J., Bogg, T., Bobova, L., & Cantrell, H. (2009). Reduced cognitive ability in alcohol dependence: Examining the role of covarying externalizing psychopathology. *Journal of Abnormal Psychology*, 118, 100-116.

76. Fossati A., Maffei C., Bagnato M., Battaglia M., Donati D., Donini M., Fiorilli M., Novella L., & Prolo F. (2000). Patterns of covariation of DSM-IV personality disorders in a mixed psychiatric sample. *Comprehensive Psychiatry*, 41, 206-215.
77. Frick, P. J., Cornell, A. H., Bodin, S. D., Dane, H. E., Barry, C. T., & Loney, B. R. (2003). Callous-unemotional traits and developmental pathways to severe conduct problems. *Developmental Psychology*, 39, 372-378.
78. Frick, P. J., & Dickens, C. (2006). Current perspectives on conduct disorder. *Current Psychiatry Reports*, 8, 59-72.
79. Galen, L.W., Brower, K.J., Gillespie, B.W., & Zucker, R.A. (2000). Sociopathy, gender, and treatment outcome among outpatient substance abusers. *Drug and Alcohol Dependence*, 61, 23-33.
80. Gillen, R., & Hessebrock, V. (1992). Cognitive functioning, ASP, and family history of alcoholism in young men at risk for alcoholism. *Alcoholism: Clinical and Experimental Research*, 16, 206-214.
81. Goyer, P. F., Andreason, P. J., Semple, W. E., Clayton, A. H., King, A. C., Compton-Toth, B. A., et al. (1994). Positron-emission tomography and personality disorders. *Neuropsychopharmacology*, 10(1), 21-28.
82. Gunn, J., & Robertson, G. (1976). Drawing a criminal profile. *British Journal of Criminology*, 16 (2), 156-160.
83. Gustavson C, Ståhlberg O, Sjödin, A-K, Forsman A, Nilsson T, Anckarsäter H. (2007). Age at onset of substance abuse: a crucial covariate of psychopathic traits and aggression in adult offenders. *Psychiatry Research*. 153:195-198.
84. Haapasalo, J., Pokela, E. (1999). Child rearing and child abuse antecedents of criminality. *Aggression and Violent Behavior*, 1, 107-127.

85. Hare, R.D. (1991) *The Hare Psychopathy Checklist - Revised*. North Tonawanda, NY: Multi-Health Systems.
86. Hare, R.D. (1996). Psychopathy and antisocial personality disorder: A case of diagnostic confusion. *Psychiatric Times*, 13. Retrieved June 10, 2008 from <http://www.psychiatrictimes.com/display/article/10168/51816>.
87. Hare, R. D. (2003). *The Hare Psychopathy Checklist – Revised: 2nd Edition* Toronto: Multi-Health Systems Inc.
88. Hare, R.D., Harpur, T.J., Hakstian, A.R., Forth A.E., Hart, S.D., & Newman, J.P. (1990). The Revised Psychopathy Checklist: Reliability and factor structure. *Psychological Assessment*, 2, 338-341.
89. Hare, R. D., Hart, S. D., & Harpur, T. J. (1991). Psychopathy and the DSM-IV criteria for antisocial personality disorder. *Journal of Abnormal Psychology*, 100 (3): 391-398.
90. Hare, R. D., & Neumann, C. S (2006). The PCL-R assessment of psychopathy: Development, structural properties, and new directions. In C. J. Patrick (Ed.), *Handbook of psychopathy* (pp. 58-88). New York: Guilford Press.
91. Hare, R.D., Clark, D., Grann, M., & Thornton, D. (2000). Psychopathy and the predictive validity of the PCL-R: An international perspective. *Behavioral Sciences and the Law*, 18, 623-645.
92. Hare, R. D., & Neumann, C. S. (2009). Psychopathy: Assessment and forensic implications. *Canadian Journal of Psychiatry*, 54(12), 791-802.
93. Harris, E.C., & Barraclough, B. (1998). Excess mortality of mental disorder. *British Journal of Psychiatry*, 173, 11-53

94. Harris, G.T., Rice, M.T., & Cormier, C.A. (1991). Psychopathy and violent recidivism. *Law and Human Behaviour, 15*, 625-637.
95. Harpur, T.J., Hare, R.D., & Hakstian, A.R. (1989). Two-factor conceptualization of psychopathy: Construct validity and assessment implications. *Psychological Assessment, 1*, 6-17.
96. Hayes, A. F., & Matthes, J. (2009). Computational procedures for probing interactions on OLS and logistic regression: SPSS and SAS implementations. *Behaviour Research Methods, 41* (3), 924-936.
97. Haynes, S. N. (1992). *Models of causality on psychopathology: Toward dynamic, synthetic and nonlinear models of behaviour disorders*. New York: MacMillan.
98. Hemphill, J.F., Hare, R.D., and Wong, S. (1998). Psychopathy and recidivism: A review. *Legal and Criminological Psychology, 3*, 139-170.
99. Hesselbrock, M. N., Meyer, R.E., & Keener, J.J. (1985). Psychopathology in hospitalized alcoholics. *Archives of General Psychiatry, 42*, 1050-1055.
100. Home Office and Department of Health. (2001). *DSPD Programme: Dangerous people with severe personality disorder Initiative: Progress report*. London: Home Office.
101. Horton, J., Compton, W.M., & Cottler, L.B. (1998). Assessing psychiatric disorders among drug users: Reliability of the revised DIS-IV. In L. Harris (Ed.), *NIDA Research Monograph-Problems of Drug Dependence*. Washington, DC: NIH Publication No. 99-4395.
102. Howard, R. (2006). How is personality disorder linked to dangerousness? A putative role for early-onset alcohol abuse. *Medical Hypotheses, 67*, 702-708.
103. Howard, R. C. (2009). The neurobiology of affective dyscontrol:

- Implications for understanding 'dangerous and severe personality disorder'. In M. McMurrin & R. C. Howard (Ed.), *Personality, personality disorder and violence* (pp.157-174). Chichester: J. Wiley & Sons.
104. Howard, R.C. The quest for excitement: a missing link between personality disorder and violence? *Journal of Forensic Psychiatry and Psychology*, in press.
105. Howard, R., Huband, N., Mannion, A., & Duggan, C. (2008). Exploring the link between personality disorder and criminality in a community sample. *Journal of Personality Disorder* (in press).
106. Howard, R., Huband, N. & Duggan, C. Adult antisocial syndrome with co-morbid borderline pathology: association with severe childhood conduct disorder. *Annals of Clinical Psychiatry* (in press).
107. Howard, R., Finn, P.R., Gallagher, J. & Jose, P. Adolescent-onset alcohol abuse exacerbates the influence of childhood conduct disorder on late adolescent and early adult antisocial behaviour. *Journal of Forensic Psychiatry and Psychology*, in press.
108. Kagan, J., Reznick, J.S., & Snidman, N. (1988). Biological bases of childhood shyness. *Science*, 240, 167–171.
109. Kazemian, L., & Farrington, D. P. (2010). The developmental evidence base: Desistence. In Towl. G. J. & Crighton, D. A. (eds). *Forensic Psychology*. BPS Blackwell. Blackwell Publishing Ltd (pp133-147).
110. Kendall, T., Pilling, S., Tyrer, P., Duggan, C., Burbeck, R. Meader, N. & Taylor, C. (2009). Borderline and antisocial personality disorders: summary of NICE guidance. *British Medical Journal*, 338, b93. doi: 10.1136/bmj.b93.
111. Kennealy, P. J., Skeem, J. L., Walters, G. D., & Camp, J. (2010). Do

- core interpersonal and affective traits of PCL-R psychopathy interact with antisocial behavior and disinhibition to predict violence? *Psychological Assessment*, 22 (3), 569-580.
112. Kjelsberg, E. (2006). Exploring the link between conduct disorder in adolescence and personality disorders in adulthood. *Psychiatric Times*, 23, 22-24.
113. Kjelsberg, E. (2008). The association between substance use comorbidity in adolescence and adult criminal behaviour. *Personality and Mental Health*, 2, 77-88.
114. Kirkpatrick, T., Draycott, S., Freestobe, M., Cooper, S., Twiselton, K., Watson, N., Evans, J., Hawes, V., Jones, L., Moore, C., Andrews, K., & Maden, T. (2010). A descriptive evaluation of patients and prisoners assessed for Dangerous and Severe Personality Disorder. *The Journal of Forensic Psychiatry & Psychology*, 21, 264-282.
115. Komarovskaya, I., Booker Loper, A., & Warren, J. (2007). The role of impulsivity in antisocial and violent behavior and personality disorders among incarcerated women. *Criminal Justice and Behavior*, 34, 1499-1515.
116. Kosson, D.S., Lorenz, A., & Newman, J.P. (2006). Effects of comorbid psychopathy on criminal offending and emotional processing male offenders with antisocial personality disorder. *Journal of Abnormal Psychology*, 115, 798-806.
117. Krueger, R. F., & Finger, M. S. (2001). Using item response theory to understand comorbidity among anxiety and unipolar mood disorders. *Psychological Assessment*, 13, 140-151.
118. Krueger, R. F., Hicks, B. M., Patrick, C.J., Carlson, S.R., Iacono, W.G., & McGue, M. (2002). Etiologic Connections Among Substance Dependence, Antisocial Behavior, and Personality: Modeling the

- Externalizing Spectrum. *Journal of Abnormal Psychology*, 111 (3) 411–424.
119. Kruesi, M. J. P., & Casanova, M. V. (2006). White matter in liars. *British Journal of Psychiatry*, 188, 293-294.
120. Kruesi, M.J.P., Rapoport, J.L., Hamburger, S. et al. (1990). Cerebrospinal fluid monoamine metabolites, aggression, and impulsivity in disruptive behaviors of children and adolescents. *Archives of General Psychiatry*, 47, 419–426.
121. Kruesi, M. J. P., Casanova, M. F., Mannheim, G., & Jonson-Bilder, A. (2004). Reduced temporal lobe volumes in early onset conduct disorder. *Psychiatry Research: Neuroimaging*, 132, 1-11.
122. Kuruoglu, A. C., Arikan, Z., Vural, G., Karatas, M., Arac, M., & Isik, E. (1996). Single photon emission computerised tomography in chronic alcoholism. Antisocial personality disorder may be associated with decreased frontal perfusion. *British Journal of Psychiatry*, 169 (3), 348–354.
123. Johnstone, S. J., & Barry, R. J. (1996). Auditory event-related potentials to a two-tone auditory discrimination paradigm in attention deficit hyperactivity disorder. *Psychiatry Research*, 64, 179–192.
124. Jolliffe, D., & Farrington, D.P. (2009). A systematic review of the relationship between childhood impulsiveness and later violence: In McMurrin, M., & Howard, R. (Eds). *Personality, Personality Disorder and Violence* (pp 41-61). Chichester: John Wiley & Sons, Ltd.
125. Juhasz, C., Behen, M. E., Muzik, O., Chugani, D. C., & Chugani, H. T. (2001). Bilateral medial prefrontal and temporal neocortical hypometabolism in children with epilepsy and aggression. *Epilepsia*, 42, 991-1001.
126. Lahey, B.B., Loeber, R., Burke, J.D., & Applegate, B. (2005).

- Predicting future antisocial personality disorder in males from a clinical assessment in childhood. *Journal of Consulting and Clinical Psychology, 73*, 389-399.
127. Lejuez, C.W., Magidson, J.R., Mitchell, S.H., Sinha, R., Stevens, M., & de Wit. H. (2010). Behavioral and biological indicators of impulsivity in the development of alcohol use, problems, and disorders. *Alcoholism: Clinical and Experimental Research, 34* (8), 1334-1345.
128. Leistico, A. R., Salekin, R. T., DeCoster, J., & Rogers, R. (2008). A large-scale meta-analysis relating the Hare measures of psychopathy to antisocial conduct, *Law and Human Behavior, 32*, 28-45.
129. Lelliot, P., Audini, B., & Duffett, R. (2001) Survey of patients from an inner-London health authority in medium secure psychiatric care. *British Journal of Psychiatry, 178*, 62 - 66.
130. Little RJA & Rubin DB (2002). *Statistical analysis with missing data*. New York, NY: John Wiley & Sons.
131. Liu, J., & Raine, A. (2006). The effect of childhood malnutrition on externalizing behavior. *Current Opinions in Pediatrics, 18*, 565-570.
132. Liu, J., Raine, A., Venables, P., & Mednick, S.A. (2004). Malnutrition at age 3 years predisposes to externalizing behaviour problems at age 8, 11, and 17 years. *American Journal of Psychiatry, 161*, 2005-2013.
133. Loeber, R., & Burke, J. D. (2011). Developmental pathways in juvenile externalizing and internalizing problems. *Journal of Research on Adolescence, 21* (1), 34-46.
134. Loeber, R., Burke, J. D., Lahey, B. B., Winters, A., & Zera, M.

- (2000). Oppositional defiant and conduct disorder: A review of the past 10 years, Part I. *Journal of American Academy of Child and Adolescent Psychiatry*, 39 (12), 1468-1484.
135. Logan, C., & Johnstone, L. (2010). Personality disorder and violence: making the link through risk formulation. *Journal of Personality Disorders*, 24 (5), 610-633.
136. Loney, B. R., Butler, M. A., Lima, E. N., Counts, C. A., & Eckel, L. A. (2006). The relation between salivary cortisol, callous unemotional traits, and conduct problems in an adolescent non-referred sample. *Journal of Child Psychology and Psychiatry*, 47 (1), 30-36.
137. Loranger A. (1997). International Personality Disorder Examination (IPDE). Psychological Assessment Resources, Inc.
138. Loranger, A.W., Sartorius, N., Andreoli, A., Berger, P., Buchheim, P., Channabasavanna, S.M., Coid, B., Dahl, A., Diekstra, R.F.W., Ferguson, B., Jacobsberg, L. B., Mombour, W., Pull, C., Ono, Y., Regier, D.A. (1994) The International Personality Disorder Examination: The World Health Organisation and Alcohol, Drug Abuse and Mental Health Administration international pilot study of personality disorders. *Archives of General Psychiatry*, 51, 215-224.
139. Lumsden, J., Hadfield, J., Littler, S. & Howard, R. (2005). The prevalence of early onset alcohol abuse in mentally disordered offenders. *Journal of Forensic Psychiatry and Psychology*, 16 (4), 651-659.
140. Maden, A. (2007). Dangerous and severe personality disorder: antecedents and origins. *British Journal of Psychiatry*, 190 (suppl. 49), s 8-s11.
141. Martin, R., L., Cloninger, R., Guze, S. B., Paula, J., & Clayton, M. D. (1985). Mortality in a follow up of 500 psychiatric outpatients. *Archives of General Psychiatry*, 42 (1), 47-54.

142. McMurrin, M., & Howard, R. (2009). *Personality, Personality Disorder and Violence*. Chichester: John Wiley & Sons, Ltd.
143. McMurrin, M., Khalifa, N., Gibbon, S. (2009). *Forensic Mental Health*. Cullompton, Devon: Willan.
144. McQueeney, T., Schweinsburg, B. C., Schweinsburg, A. D., Jacobus, J., Bava, S., Frank, L. R. & Tapert, S. F. (2009). Altered White Matter Integrity in Adolescent Binge Drinkers. *Alcohol: Clinical & Experimental Research*. 33, 1278-1285.
145. Melzer, D., Tom, B. D. M., Brugha, T., Fryers, T., Gatward, R., Grounds, A., Johnson, T., & Meltzer, H. (2004). Access to medium secure psychiatric care in England and Wales. 1: A national survey of admission assessments. *The Journal of Forensic Psychiatry and Psychology*, 15, 7-31.
146. Meltzer, H., Gatwood, R., Goodman, R. & Ford, T. (2000). *Mental health of children and adolescents in Great Britain*, TSO: London
147. Menard, S. (1995). *Applied logistic regression analysis*. Sage University paper series on quantitative applications in the social sciences, 07-106. Thousands Oaks, CA: Sage.
148. Moffitt, T. E. (1993). Adolescence-limited and life-course persistent antisocial behavior: A developmental taxonomy. *Psychological Review*, 100, 674 – 701.
149. Moffitt, T. E. & Henry, B. (1989). Neuropsychological assessment of executive function in self-reported delinquents. *Developmental Psychopathology*, 1, 105-118.
150. Moffitt, T. E., Lynam, D. R., & Silva, P. A. (1994). Neuropsychological tests predicting persistent male delinquency. *Criminology*, 32, 277-300.
151. Moffitt, T.E., Caspi, A., Harrington, H. & Milne, B.J. (2002). Males on

- the life-course-persistent and adolescence-limited antisocial pathways: Follow-up at age 26 years. *Development and Psychopathology*, 14, 179-207.
152. Moran, P. (1999). The epidemiology of antisocial personality disorder. *Social Psychiatry and Psychiatric Epidemiology*, 34 (5), 231-242.
153. Morash, M., & Rucker, L. (1989). An explanatory study of the connection of mother's age at childbearing to her children's delinquency in four data sets. *Crime and Delinquency*, 35, 45-93.
154. Morgan, A. B., & Lilienfeld, S. O. (2000). A meta-analytic review of the relation between antisocial behavior and neuropsychological measures of executive function. *Clinical Psychology Review*, 20 (1), 113-136.
155. Myers, R. (1990). *Classical and modern regression with applications (2nd Edition)*. Boston, MA: Duxbury.
156. Myers, M.G., Stewart, D.G. & Brown, S.A. (1998). Progression from conduct disorder to antisocial personality disorder following treatment for adolescent substance abuse. *American Journal of Psychiatry*, 155, 479-485.
157. Needleman, H.L., Riess, J.A., Tobin, M.J., Biesecker, G.E., & Greenhouse, J.B. (1996), Bone lead levels and delinquent behavior. *JAMA*, 275, 363-369.
158. Nestor, P.G. (2002). Mental disorder and violence: Personality dimensions and clinical features. *American Journal of Psychiatry*, 159, 1973-1978.
159. Nock, M. K., Kazdin, A. E., Hiripi, E., & Kessler, R. C. (2007). Lifetime prevalence, correlates, and persistence of oppositional defiant disorder: Results from the National Comorbidity Survey

- Replication. *Journal of Child Psychology and Psychiatry*, 48, 703 – 713.
160. Paris, J. (2003). *Personality disorders over time: Precursors, course, and outcome*. Arlington, Va: American Psychiatric Publishing.
161. Passamonti, L., Fairchild, G., Goodyer, I. M., Hurford, G., Hagan, C. C., Rowe, J. B., & Calder, A. J. (2010). Neural abnormalities in early-onset and adolescent-onset conduct disorder. *Archives of General Psychiatry*, 67, 729-738.
162. Patrick, C. J. (2006). Back to the future: Cleckley as a guide to the next generation of psychopathy research. In C. J. Patrick (Ed.), *Handbook of Psychopathy* (pp. 605-617). New York, NY: Guilford Press.
163. Patrick, C. J. (2008). Psychophysiological correlates of aggression and violence: an integrative review. *Philosophical Transactions of the Royal Society B*, 363, 2543-2555.
164. Patrick, C. J., Bernat, E., Malone, S. M., Iacono, W. G., Kreuger, R. F., & McGue, M. K. (2006). P300 amplitude as an indicator of externalizing in adolescent males. *Psychophysiology*, 43 (1), 84-92.
165. Patrick, C. J., & Verona, E. (2007). The psychophysiology of aggression: autonomic, electrocortical, and neuroimaging findings. In Flannery, D. J., Vazsonyi, A.T., & Waldman, I. D. (Ed). *The Cambridge handbook of violent behavior and aggression*, New York, NY, US: Cambridge University Press.
166. Patrick, C.J. & Bernat, E.M. (2006). The construct of emotion as a bridge between personality and psychopathology. In R.F. Krueger & J. Tackett (Eds.), *Personality and Psychopathology*, pp. 174-209. New York, Guilford Press.
167. Patrick, C. J., & Bernat, E. M. (2009). From markers to

- mechanisms: Using psychophysiological measures to elucidate basic processes underlying aggressive externalizing behavior. In: S. Hodgins, E. Viding, & A. Plodowski (Eds.) , *Persistent violent offenders: Neuroscience and rehabilitation* (pp. 223-250). London: Oxford University Press.
168. Patrick, C. J., Fowles, D. C., & Krueger, R. F. (2009). Triarchic conceptualization of psychopathy: Developmental origins of disinhibition, boldness, and meanness. *Development and Psychopathology*, 21, 913-938.
169. Patrick, C. J., & Bernat, E. M. (2010). Neuroscientific foundations of psychopathology. In T. Millon, R. F. Krueger, & E. Simonsen (Eds.), *Contemporary directions in psychopathology: Toward the DSM-V*, pp.419-452. New York: Guilford Press.
170. Pereira, S., Dawson, P., & Sarsam, M. (2006).The National Survey of PICU and Low Secure Services: 2 unit characteristics. *The Journal of Intensive Care*, 2, 13-19.
171. Pine, D.S., Coplan, J.D., Wasserman, G.A., et al. (1997). Neuroendocrine response to fenfluramine challenge in boys: associations with aggressive behaviour and adverse rearing. *Archives of General Psychiatry*, 54, 839-846.
172. Poythress, N.G., Edens, J.F., Skeem, J.L., Lilienfeld, S.O., Douglas, K.S., Frick, P.J., Patrick, C.J., Epstein, M. & Wang, T. (2010). Identifying Subtypes Among Offenders With Antisocial Personality Disorder: A Cluster-Analytic Study. *Journal of Abnormal Psychology*, 119, 389-400.
173. Poustka, L., Maras, A., Hohm, E., Fellingner, J., Holtmann, M., Banaschewski, T., Lewicka, S., Schmidt, M. H., Esser, G., & Laucht, M. (2010). Negative association between plasma cortisol levels and

- aggression in a high-risk community sample of adolescents. *Journal of Neural Transmission*, 117, 621-627.
174. Pratt, T. C., & Cullen, F. T. (2000). The empirical status of Gottfredson & Hirschi's general theory of crime: A meta-analysis. *Criminology*, 38, 931-964.
175. Pratt, T. C., Cullen, F. T., Blevins, K. R., Daigle, L., Unnever, J. D., (2002). The relationship of attention hyperactivity disorder to crime and delinquency: A meta-analysis. *International Journal of Police Science and Management*, 4, 344-360.
176. Preacher, K. J., & Hayes, A. F. (2008). Asymptotic and resampling strategies for assessing and comparing indirect effects in multiple mediator model. *Behaviour Research Method*, 40 (3), 879-891.
177. Quayle, M., Clark, F., Renwick, S.J., Hodge, J. & Spencer, T. (1998). Alcohol and secure hospital patients: I. An examination of the nature and prevalence of alcohol problems in secure hospital patients. *Psychology, Crime and Law*, 4, 27-41.
178. Raine, A. (2002). Biosocial studies of antisocial and violent behaviour in children and adults: A review. *Journal of Abnormal Child Psychology*, 30 (4), 311-326.
179. Raine, A., & Yang, Y. (2006). The neuroanatomical bases of psychopathy: A review of brain imaging findings. In C. J. Patrick (Ed.), *Handbook of Psychopathy*. New York: Guilford Press.
180. Raine, A., Venables, P. H., & Williams, M. (1990). Relationships between N1, P300 and CNV recorded at age 15 and criminal behaviour at age 24. *Psychophysiology*, 27, 567-575.
181. Raine, A., Venables, P. H., & Williams, M. (1995). High autonomic arousal and electrodermal orienting at age 15 years as protective factors against criminal behavior at age 29 years. *American Journal of Psychiatry*, 152, 1595-1600.

182. Raine, A., Brennan, P., & Mednick, S. A. (1997). Interaction between birth complications and early maternal rejection in predisposing individuals to adult violence: Specificity to serious, early-onset violence. *American Journal of Psychiatry*, *154*, 1265–1271.
183. Raine, A., Buchsbaum, M, Lencz, T., Bihrlle, S., LaCasse, L., Colletti, P. (2000). Reduced prefrontal gray matter volume and reduced autonomic activity in antisocial personality disorder. *Archives of General Psychiatry*, *57*, 119–127.
184. Raine, A., Park, S., Lencz, T., Bihrlle, S., LaCasse, L., Widom, C. S., et al. (2001). Reduced right hemisphere activation in severely abused violent offenders during a working memory task: An fMRI study. *Aggressive Behavior*, *27*, 111–129
185. Reich, J. H. & Vasile, R. G. (1993) Effect of personality disorders on the treatment outcome of Axis 1 conditions: an update. *Journal of Mental and Nervous Diseases*, *181*, 475–484.
186. Robins, L.N. (1966). *Deviant children grown up*. Williams and Wilkins: Baltimore.
187. Robins, L.N. (1978). Sturdy childhood predictors of antisocial behaviour: replications from longitudinal studies. *Psychological Medicine*, *8*, 611-622.
188. Robins, L., Helzer, J., Cottler, L.B. & Goldring, E. (1989). National Institute of Mental Health: *Quick Diagnostic Interview Schedule-Revised (NIMH-QDISIIR)*. St. Louis, Missouri: Department of Psychiatry, Washington University School of Medicine.
189. Robins, L. N., West, P. J., & Herjanic, B. L., (1975). Arrest and delinquency in two generations: a study of black urban families and their children. *Journal of Child Psychology and Psychiatry*, *16*, 125-140.

190. Royal College of Psychiatrists. (1986). *Alcohol: Our favourite drug*.
New report on alcohol and alcohol-related problems from a special committee of the Royal College of Psychiatrists. London: Tavistock Publications.
191. Rubin, D.B. (1987) *Multiple Imputation for Nonresponse in Surveys*. J. Wiley & Sons, New York.
192. Rueter, M.A., Chao, W., & Conger, R.D. (2000). The effect of systematic variation in retrospective Conduct Disorder reports on Antisocial Personality Disorder diagnoses. *Journal of Consulting and Clinical Psychology, 68*, 307-312.
193. Sayal, K, Heron, J., Golding, J., Alati, R., Smith, G. D., Gray, R., & Emond, A. (2009). Binge pattern of alcohol consumption during pregnancy and childhood mental health outcomes: longitudinal population-based study. *Pediatrics, 123*, e289-e296.
194. Schafer JL & Graham JW (2002). Missing data: Our view of the state of the art. *Psychological Methods, 7*, 147-77.
195. Schwartz, C. E., Snidman, N., Kagan, J. (1996). Early childhood temperament as a determinant of externalizing behaviour in adolescence. *Development and Psychopathology, 8*, 527-537.
196. Schug, R. A., Gao, Y., Glenn, A. L., Peskin, M., Yang, Y., & Raine, A. (2010). The developmental evidence base: neurobiological research and forensic applications: In Towl. G. J. & Crighton, D. A. (eds). *Forensic Psychology*. BPS Blackwell. Blackwell Publishing Ltd.
197. Shapiro, D. (1965). *Neurotic styles*. New York, Basic books.
198. Skeem, J., & Cooke, D.J. (2010). Is criminal behaviour a central component of psychopathy? Conceptual directions for resolving the debate. *Psychological Assessment, 22* (2), 433-445.
199. Skodol, A. E. (2011). Scientific issues in the revision of personality disorders for DSM-5. *Personality and Mental Health, 5* (2), 97-111.

200. Smith, C. A., & Stern, S. B. (1997). Delinquency and antisocial behavior : A review of family processes and intervention research. *Social Service Review*, 71, 382-420.
201. Sobel, M. E. (1982). Asymptotic confidence intervals for indirect effects in structural equations models. In S. Leinhardt (Ed.), *Sociological methodology 1982* (pp. 290-312). San Francisco: Jossey-Bass.
202. Soderstrom, H., Sjodin, A. K., Carlstedt, A., & Forsman, A. (2004). Adult psychopathic personality with childhood-onset hyperactivity and conduct disorder: a central problem constellation in forensic psychiatry. *Psychiatry Research*, 121, 271-280.
203. Sterzer, P., Stadler, C., krebs, A., Kleinschmidt, A., Poustka, F. (2005). Abnormal neural responses to emotional visual stimuli in adolescents with conduct disorder. *Biological psychiatry*, 57, 7-15.
204. Stålenheim, EG, Von Knorring, L (1996), Psychopathy and Axis I and Axis II psychiatric disorders in a forensic psychiatric population in Sweden. *Acta Psychiatrica Scandinavica*, 94, 217–223.
205. Taylor, P. J., Leese, M., Williams, D., Butwell, M., Daly, R., & Larkin, E. (1998). Mental disorder and violence. A special (high security) hospital study. *British Journal of Psychiatry*, 172, 218-226.
206. Thapar, A., van den Bree, M., Fowler, T., Langley, K., & Whittinger, N. (2006). Predictors of antisocial behaviour in children with attention deficit hyperactivity disorder. *European Journal of Child and Adolescent Psychiatry*, 15, 118-125.
207. The R Foundation for Statistical Computing Version 2.1.1 (2005). ISBN 3-900051-07-0.
208. The Sainsbury Centre for Mental Health. (2005). *Defining Good Mental Health service: A Discussion Paper*. The Sainsbury Centre, London.

209. Thornton, D., Mann, R., Webster, S., Blud, L., Travers, R., Friendship, C., et al. (2003). Distinguishing and combining risks for sexual and violent recidivism. *Annals of the New York Academy of Sciences*, 989, 225–235.
210. Torgersen S, Czajkowski N, Jacobson K, Reichborn-Kjennerud T, Røysamb, E., Neale, M.C., & Kendler, K.S. (2008). Dimensional representations of DSM-IV cluster B personality disorders in a population-based sample of Norwegian twins: a multivariate study. *Psychological Medicine*, 38, 1617-1625.
211. Tyrer, P. & Johnson, T. (1996) Establishing the severity of personality disorder. *American Journal of Psychiatry*, 153:1593-1597.
212. Tyrer, P & Garralda, E. (2005) developments in the assessment and classification of personality disorders. *Psychiatry*, 4:1-4.
213. Tyrer, P., Barrett, B., Byford, S., Cooper, S. Crawford, M., Cicchetti, D., Duggan, D., Joyce, E., Kirkpatrick, T., Maier, M., O’Sullivan, S., Maden, A., & Rogers, R. Rutter, D., Seivewright, H. (2007). *Evaluation of the assessment procedure at two pilot sites in the DSPD programme (IMPALOX Study)*. DSPD Programme. Retrieved from on 24th March 2011 from the DSPD Programme website; <http://www.dspdprogramme.gov.uk/publications.html>
214. Ullrich, S., & Coid, J. (2010). Antisocial personality disorder-stable and unstable subtypes. *Journal of Personality Disorders*, 24 (2) 171-187.
215. Unis, A.S., Cook, E.H., Vincent, J.G. et al., 1997), Platelet serotonin measures in adolescents with conduct disorder. *Biological Psychiatry*, 42, 553–559.
216. Varlamov, A., Khalifa, N., Liddle, P., Duggan, C., & Howard, R.

- (2011). Cortical correlates of impaired self-regulation in personality disordered patients with traits of psychopathy. *Journal of Personality Disorders, 25*(1), 75-88.
217. Viera, A.J., & Garrett, J. (2005). Understanding interobserver agreement: The Kappa statistic. *Family Medicine, 37* (5), 360-363).
218. Volkow, N.D., Tancredi, L.R., Grant, C., Gillespie, H., Valentine, A., Mullani, N., Wang, G.J., Hollister, L. (1995). Brain glucose metabolism in violent psychiatric patients: a preliminary study. *Psychiatry Research, 61*, 243-253.
219. Völlm, B., Richradson, P., McKie, S., Elliott, R., Deakin, J. F. W., & Anderson, I. M. (2006). Serotonergic modulation of neuronal responses to behavioural inhibition and reinforcing stimuli: an fMRI study in healthy volunteers. *European Journal of Neuroscience, 23*, 552-560.
220. Völlm, B. (2007). *The neurobiology of impulsivity and social cognition in normal and antisocial individuals*. Doctoral thesis. The University of Manchester.
221. Wahlund, K., & Kristiansson, M. (2009). Aggression, psychopathy and brain imaging – Review and future recommendations. *International Journal of Law and Psychiatry, 32*, 266-271.
222. Walters, G. D. (2003). Predicting institutional adjustment and recidivism with the Psychopathy Checklist factor scores: A meta-analysis. *Law and Human Behavior, 27*, 541-558.
223. Walters, G.D., & Knight, R.A. (2010). Antisocial personality disorder with and without antecedent conduct disorder: does it make a difference? *Journal of Personal Disorders, 24*, 258-271.
224. Walter, M., Wiesbeck, G., Dittmann, V., Graf, M. (2011). Criminal

- recidivism in criminals with personality disorders and substance use disorders over 8 years of time at risk. *Psychiatry Research*, 186, 443-445.
225. Wells, J. E., Horwood, L. J. & Fergusson, D. M. (2004). Drinking patterns in mid-adolescence and psychosocial outcomes in late adolescence and early adulthood. *Addiction*, 99, 1529-1541.
226. Weschler, D. (1997). *Weschler Adult Intelligence Scale-III*. New York: The Psychological Corporation.
227. White, J. L., Moffitt, T. E., Caspi, A., Bartusch, D. J., Needles, D.J., & Stouthamer-Loeber, M. (1994). Measuring impulsivity and examining its relationship to delinquency. *Journal of Abnormal Psychology*, 103, 192-205.
228. Whiteside, S. P. & Lynam, D. R. (2001). The five factor model and impulsivity: using a structural model of personality to understand impulsivity. *Personality and Individual Differences*, 30, 669 – 689.
229. Wong, M., Lumsden, J., Fenton, G., & Fenwick, P. (1993). Violence ratings of special hospital patients. *Journal of Forensic Psychiatry*, 4, 471-480.
230. World Health Organisation (1992). *10th Revision of the International Classification of Diseases (ICD-10)*. Geneva: WHO.
231. Yang, M., Wong, S.C.P., & Coid, J. (2010). The Efficacy of Violence Prediction: A Meta-Analytic Comparison of Nine Risk Assessment Tools. *Psychological Bulletin*, 136, (5) 740-767.
232. Zernicke, K.A., Cantrell, H., Finn, P.R., and Lucas, J. (2010). The association between earlier age of first drink, disinhibited personality, and externalizing psychopathology in young adults. *Addictive Behaviors*, 35 (5), 414-418.
233. Zimmerman, M. (1994) Diagnosing Personality Disorders: a Review

of issues and Research Methods. *Archives of General Psychiatry*. 51, 225-245.

234. Zimmerman, M., Rothschild, L. & Chelminski, I. (2005). The prevalence of DSM-IV personality disorders in psychiatric outpatients. *American Journal of Psychiatry*, 162, 1911-1918.

235. Zimmerman, M. & Coryell, W.H. (1990). DSM-III personality disorder dimensions. *The journal of Nervous and Mental Disease*, 178, 686-692.

APPENDICES

A. Appendix I: Drug and Alcohol Assessment Protocol (Lumsden et al, 2005)

1. General questions

- When is your first memory of tasting alcohol? (age) _____
- When did you start to drink alcohol regularly, say once or more a month? _____
- Why did you start to drink more regularly? _____
- How old were you when you first got drunk? _____
- If you believe that drinking alcohol was a problem for you in the past, at what age did you realise alcohol was a problem for you?
- Look back on your life and think of the period when you drank the most. How old were you then? _____

2. Drinking category key

Please point at the definition that corresponds to the drinking category to which you believe your father and mother belong to

Category	Definition	Father	Mother
Abstainer	Does not drink alcohol, except for possibly a few units a few times a year		
Light drinker	Drinks only a little (0-6 units a week), and not more than two days a week.		
Moderate drinker, Binge drinker	Drinks regularly, or irregularly, about 0-40 for men units a week, with the average being over the light drinker.		
Heavy drinker, alcoholic	Drinks more or less every day, more than 40 units a week.		
Problem drinker	A heavy drinker who also is thought to be dependent on alcohol and who would drink in spite of alcohol related problems.		

3. Consumption level life graph

Use this space to elicit information about how much the patient drank weekly across their life. There is no need to be exact, only a very

If Yes: In what way?

5. Drug history

Please answer next to each drug category whether you have ever used the drug (YES or NO answer); and if so, how often? If possible give some indication of quantity used, regularly / daily.

NAME	Never	Tried	Regular use	Daily use	Quantity
Opiates e g heroin, morphine, methadone					
Stimulants e g cocaine, crack or freebase, purple hearts, amphetamines or speed,					
Ecstasy e g white doves, disco burgers, New Yorkers					
Cannabis e g marijuana, grass, hash, hashish					
Hallucinogens e g LSD acid strawberries, Chinese dragon, pink panther, liberty cap or magic mushrooms					
Sedatives E g hypnotics & benzodiazepines					
Anabolic steroids					
Solvents e g glue – evostick, paint, petrol, aerosol sprays, butane gas, lighter fuel, tippex					
Other e g tobacco (specify)					

- Did you use any of the following drugs before the offence?

Cannabis Amphetamine Cocaine Heroin
 Hallucinogens/LSD Other

- When was the last time prior to the offence that you took one of these substances? _____ mins, hrs, days, weeks, months, years
- Did you (ever) exceed your normal dose? Yes No
- By how many times larger would the dose be? (x2, x3, etc).
- Can you describe your drug use in the week before the offence? (Mark drug use with an X, abstention with an O, in the space above the day):

Day 7	Day 6	Day 5	Day 4	Day 3	Day 2	Day 1	Day of index offence

B. Appendix II: Personality Disorder Severity Scale (Tyrer & Johnson, 1996)

Level of Severity	Description	Definition
4	Severe	Meets criteria for APD and has at least one other PD in another cluster
3	Diffuse	Meets criteria for more than 1 PD within more than one cluster (excluding APD)
2	Simple	Meets criteria for one or more PDs within the same cluster
1	Personality difficulty	meets sub-threshold criteria for one or more personality disorders; has at least 10 traits indicative of any one personality disorder ("Not Otherwise Specified, NOS");
0	No PD	<10 traits

viii. Miscellaneous minor charges (vandalism, causing a disturbance, mischief, wilful damage, minor driving offences...etc.)

ix. Other

3. Number of offences where alcohol involved

4. Number of offences where drugs other than alcohol were involved.

5. Age at first offence

6. Age at first violent offence

7. Psychiatric service contacts prior to age 18:	No	Yes
Number		

8. Psychiatric inpatient care prior to age 18	No	Yes
Number		

9. Periods of institutional care prior to age 18	No	Yes
Number		

10. Convictions prior to age 18	No	Yes
Number		

11. Convictions since age 18	No	Yes
Number		

12. Imprisonments prior to age 18	No	Yes
Number		

13. Imprisonments since age 18	No	Yes
Number		

D. Appendix IV: Violence Severity Rating Scale (Gunn & Robertson, 1976)

1. Violence rating for admission (index) offence	
No violence	0
Minimal violence: (e.g., verbally aggressive, shouting or gesturing, even if this was not obviously directed at others)	1
Moderate violence: (e.g., attack on a person resulting in no serious injury, fighting or brawling or damage to property when this was the main intent)	2
Moderately severe violence: (eg attack which resulted in serious injury but not detention in hospital for more than 24 hrs, or damage to property which was extensive or which could have resulted in threat to life)	3
Severe violence: (victim died or life and health seriously endangered)	4
2. Violence rating for previous criminal record	
Never been convicted of violence – never gets into fights	0
Some evidence of violence (occasional fights but no convictions)	1
One or two convictions for minor assaults or damage to property	2
Three or more convictions for violence, but none serious in the sense of '4' below	3
One or more severely episode in which someone's life or health has been seriously endangered	4
3. Violence rating for current institutional behaviour	
No incidents of aggression (verbal/physical or damage to property)	0
Evidence of occasional intimidation, verbal aggression or minor property damage	1
Verbal threats of serious violence (e.g., I'll kill you) <i>or</i> one or two incidents of physical aggression to others not causing significant injury, e.g. pushes, shoves, grabs clothing etc.	2
Three or more incidents of physical aggression without significant injury <i>or</i> any incident of physical aggression resulting in injury, e.g. bruises, sprains, abrasions etc, but none serious in the sense of '4' below	3
One or more <u>severely</u> violent episodes in which someone's life or health was seriously endangered, or any incident involving the use of a weapon against another person.	4

Total score (1+2+3) = _____

E. Appendix V: UPPS Impulsive Behaviour Scale (Whiteside & Lynam, 2001)

Instructions: below are a number of statements that describe ways in which people act and think. For each statement, please indicate how much you agree or disagree with the statement. If you Disagree Strongly circle **1**, If you **Disagree Strongly** circle **1**, if you **Disagree Somewhat** circle **2**, if you **Agree somewhat** circle **3**, and if you **Agree Strongly** circle **4**. Be sure to indicate your agreement or disagreement for every statement below.

1. I have a reserved and cautious attitude toward life.	1	2	3	4
2. I have trouble controlling my impulses.	1	2	3	4
3. I generally seek new and exciting experiences and sensations.	1	2	3	4
4. I generally like to see things through to the end.	1	2	3	4
5. My thinking is usually careful and purposeful.	1	2	3	4
6. I have trouble resisting my cravings (for food, cigarettes, etc.).	1	2	3	4
7. I'll try anything once.	1	2	3	4
8. I tend to give up easily.	1	2	3	4
9. I am not one of those people who blurt out things without thinking.	1	2	3	4
10. I often get involved in things I later wish I could get out of.	1	2	3	4
11. I like sports and games in which you have to choose your next move very quickly.	1	2	3	4
12. Unfinished tasks really bother me.	1	2	3	4
13. I like to stop and think things over before I do them.	1	2	3	4
14. When I feel bad, I will often do things I later regret in order to make myself feel better now.	1	2	3	4
15. I would enjoy water skiing.	1	2	3	4
16. Once I get going on something I hate to stop.	1	2	3	4
17. I don't like to start a project until I know exactly how to proceed.	1	2	3	4
18. Sometimes when I feel bad, I can't seem to stop what I am doing even though it is making me feel worse.	1	2	3	4
19. I quite enjoy taking risks.	1	2	3	4

20. I concentrate easily.	1	2	3	4
21. I would enjoy parachute jumping.	1	2	3	4
22. I finish what I start.	1	2	3	4
23. I tend to value and follow a rational, "sensible" approach to things	1	2	3	4
24. When I am upset I often act without thinking.	1	2	3	4
25. I welcome new and exciting experiences and sensations, even if they are a little frightening and unconventional.	1	2	3	4
26. I am able to pace myself so as to get things done on time.	1	2	3	4
27. I usually make up my mind through careful reasoning.	1	2	3	4
28. When I feel rejected, I will often say things that I later regret.	1	2	3	4
29. I would like to learn to fly an airplane.	1	2	3	4
30. I am a person who always gets the job done.	1	2	3	4
31. I am a cautious person.	1	2	3	4
32. It is hard for me to resist acting on my feelings.	1	2	3	4
33. I sometimes like doing things that are a bit frightening.	1	2	3	4
34. I almost always finish projects that I start.	1	2	3	4
35. Before I get into a new situation I like to find out what to expect from it.	1	2	3	4
36. I often make matters worse because I act without thinking when I am upset.	1	2	3	4
37. I would enjoy the sensation of skiing very fast down a high mountain slope.	1	2	3	4
38. Sometimes there are so many little things to be done that I just ignore them all.	1	2	3	4
39. I usually think carefully before doing anything.	1	2	3	4
40. Before making up my mind, I consider all the advantages and disadvantages.	1	2	3	4
41. In the heat of an argument, I will often say things that I later regret.	1	2	3	4
42. I would like to go scuba diving.	1	2	3	4
43. I always keep my feelings under control.	1	2	3	4
44. I would enjoy fast driving.	1	2	3	4
45. Sometimes I do impulsive things that I later regret.	1	2	3	4

F. Appendix VI: Iowa Gambling Task (Bechara, 2007)

Screen image

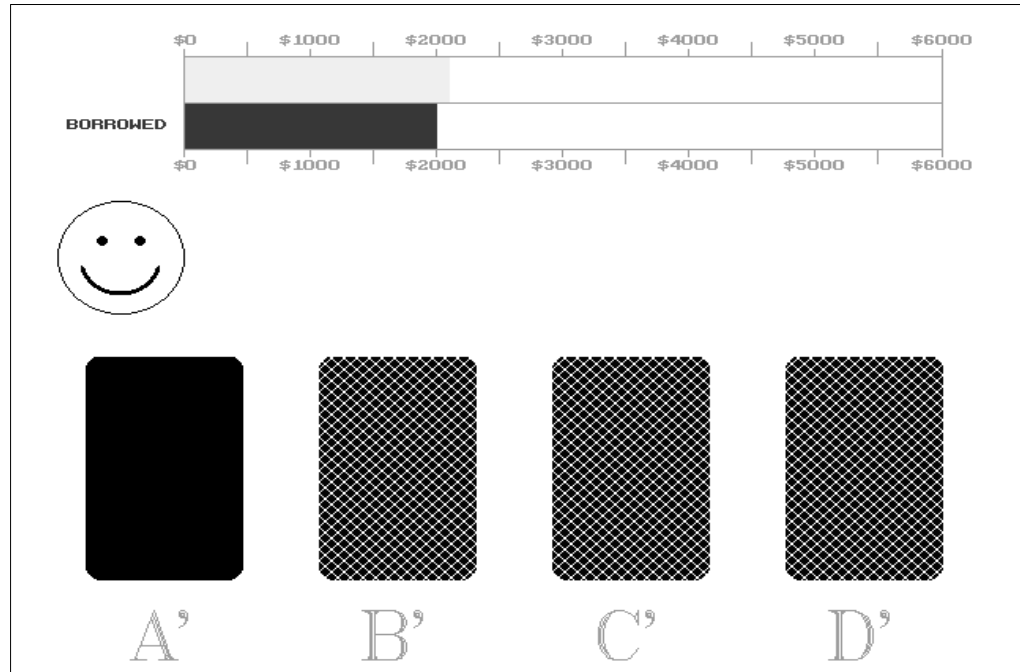

Verbal instructions: In front of you on the screen, there are four decks of cards A, B, C, and D. I want you to select one card at a time, by clicking on the card, from any deck you choose. Each time you select a card from a deck, the colour of the card turns red or black, and the computer will tell you that you won some money. I won't tell you how much money you will win. You will find out along the way. Every time you win, the green bar gets longer. Every so often, however, when you click on a card, the computer tells you that you won some money, but then it says that you also lost some money. I won't tell you when you will lose or how much you will lose. You will find out along the way. Every time you lose, the green bar gets shorter. You are absolutely free to switch from one deck to another any time you wish. The goal of the game is to win as much money as possible and, if you find yourself unable to win, make sure you avoid losing money as much as possible. I won't tell you for how long the game will continue. You must keep on playing until the computer stops. You will get this \$2000 credit (see the green bar) to start the game. At the end, we will see how much you won or lost. The red bar here is a reminder of how much money you borrowed to play the game.

It is important to know that the colours of the cards are irrelevant in this game. The computer does not make you lose money at random. However, there is no way for you to figure out when the computer will make you lose. All I can say is that you may find yourself losing money on all of the decks, but some decks will make you lose more than others. You can win if you stay away from the worst decks.

G. Appendix VII: Patient Information Sheet

You are being invited to take part in a study on drinking and personality. Please take time to read the following information carefully with your nursing team, the project organiser or an advocate if you wish. Ask us if there is anything that is not clear or if you would like more information. Take time to decide whether or not you wish to take part in this project.

Who is organising the research?

This research is being carried out as collaboration between the Peaks Academic & Research Unit (PARU), based at Rampton Hospital, and the Division of Psychiatry, University of Nottingham. The project is funded by Nottinghamshire Healthcare NHS Trust and the University of Nottingham.

Why is this project taking place?

We wish to explore the relationship, in those with a diagnosis of personality disorder, between their personality disorder, their drinking history, and their brain function. The first part of this study – this part which you are now being asked to give your consent to – involves:

1. Collecting some background information about you, including information about your personality and about your drinking history. We are seeking your permission to use, for the purpose of this study only, some of the information about you that is already on file or in your case-notes.
2. An interview and completion of some questionnaires.
3. Performing a computerised gambling game.

Who is conducting this project?

The interview will be carried out by Dr Najat Khalifa or a research assistant under his supervision.

Do I have to take part?

Whether or not you take part is for you to decide. If you choose to take part you will be given this information sheet to keep and you will be asked to sign the attached consent form, which you will also keep. You have the right to change your mind at any time without affecting the care that you receive.

What would be involved?

First you will undergo an interview, lasting about 60 to 90 minutes, in which you will be asked questions regarding your experiences with drinking alcohol and other drugs, and the sorts of psychological symptoms you have been experiencing. Then you will be given some questionnaires to fill in. One asks you about your experiences with alcohol. Others ask about ways in which you typically think, feel and act. And one asks you about any unusual thoughts you might sometimes have – most of us have unusual thoughts sometimes. Finally, you will take part in a simulated gambling game in which you choose between different decks of cards to win points. You will sit in front of a computer screen on which are shown 4 decks of cards, and you will select a card from any of the 4 decks, by clicking on the deck with the computer mouse. Selection of the card will result in you winning or losing points. You will go on selecting cards until you're told to stop. The game will last about 15-20 minutes. . Please note that this is a "pretend" gambling situation: you will not actually win or lose any money!

What are the pros & cons of taking part?

There are no particular disadvantages to taking part. On the plus side, you may find that the act of answering the questionnaires may give you some insights into the ways you typically think, feel and act. On the minus side, answering questions about your drinking history, particularly during your teenage years, may bring back some unpleasant memories of your adolescence. Since this testing is rather lengthy and will stretch from the morning into the afternoon, for your sustenance we are offering you a £10 voucher that you can use to purchase food and drink from Tesco supermarket.

How confidential will the interview be?

Confidentiality is very important for this project. What you say in the interview will not be discussed with anybody else *unless* you disclose certain information:

(i) About yourself or someone else being harmed; (ii) About an unreported crime; (iii) About a child who is being harmed. You should bear in mind these limits to confidentiality when taking part in the interview. With these exceptions, we can guarantee that whatever information you provide us with will remain completely confidential, and will not be passed to anyone who is not directly involved in the study. Your name will not appear in any data files and it will not be possible to identify you from the information we gather.

What will happen to the results of this project?

The information you provide, both from the interview and from the questionnaires, will be collated and entered, together with some background information from your case-notes, into a secure computer, which only the researchers have access to. Therefore you can be assured of the confidentiality of the information you provide us with. This information will be coded in the computer by number only - your name will never appear together with the information you give. Therefore the information we gather from you will remain anonymous and can never be traced back to you.

How can I find out about what the report says?

A summary of the results of the study will be available from Dr Khalifa. You can ask one of the nursing staff to obtain a copy for you.

What if something goes wrong?

If you are not happy with any aspect of this study and wish to make a complaint, you should speak with the researchers who will do their best to answer your questions. You can call Dr Richard Howard on 0177 7880503 or Professor Conor Duggan, who is a joint investigator on this research project and is contactable via his Secretary on 0115 9555361. If you remain unhappy and wish to complain formally, you can do this through the NHS Complaints procedure via the local Service Liaison Department on 01777 247396.

I. Appendix IX: List of Author's Publications

1. **Khalifa, N.** & Gangadharan, S. (2005) Muscle Eye Brain disease- A case report of cognitive and behavioural features. *The British Journal of Developmental Disabilities*, 51 (1): 100, 91-95.
2. **Khalifa, N.** & Hardie, T. (2005) Possession and Jinn: A review article. *Journal of The Royal Society of Medicine*, 98, 351-353.
3. Gibbon, S. & **Khalifa, N.** (2005) Recording Adverse Drug Reaction In a forensic psychiatric unit: How can we improve standards? *The British Journal of Forensic Practice*, 7 (3), 7-11.
4. Duggan, C. & **Khalifa, N.** (2007) management of personality disordered offenders in the community. *Psychiatry*, 6 (11), 470-473.
5. **Khalifa, N.**, Murchie, E. Schedlbauer, A., Rai, A. & Aluzri, M. (2007). Recent Advances in Medical undergraduate teaching in the UK. In 'for the advancement of higher education in Iraq'. Aras Press, Kurdistan-Erbil.
6. **Khalifa, N.**, Saleem, Y., & Stankard, P. (2008). The use of telepsychiatry within forensic practice: A literature review on the use of videolink. *The Journal of Forensic Psychiatry & Psychology*, 19 (1) 2.
7. Gibbon, S., Duggan, C., Langley, M. & **Khalifa, N.** (2008). *BMJ Career Focus* 336: 3-4.
8. **Khalifa, N.** & Taylor, M. (2008). Can we harmonise forensic psychiatry across Europe. *Psychiatric Bulletin*, 32: 74.
9. **Khalifa, N.**, Gibbon, S. & Duggan, C. (2008). The police and sniffer dogs in psychiatric settings: a survey. *Psychiatric Bulletin*, 32, 253-256.
10. Saleem, Y., Taylor, M. & **Khalifa, N.** (2008) Forensic telepsychiatry in the UK. *Behavioural sciences & the law*, 26, 333-344.

11. McMurrin, M., **Khalifa, N.**, & Gibbon, S. (2009). *Forensic Mental Health*. Cullompton, Devon: Willan.
12. **Khalifa, N.**, Duggan, C., Stoffers, J., Huband, N., Völlm, B.A., Ferriter, M., & Lieb, K. (2010). Pharmacological interventions for antisocial personality disorder. *Cochrane Database of Systematic Reviews* 2010, Issue 8. Art. No.: CD007667. DOI:10.1002/14651858.CD007667.pub2.
13. **Khalifa, N.**, Hardie, T., Jamil, I., Latif, S. & Walker, D.M. (2011). Beliefs about Jinn, Black Magic and Evil Eye among Muslims: age, gender and first language influences. *The International Journal of Culture and Mental Health*, 4 (1), 68-77.
14. Völlm BA, Gibbon S, **Khalifa N**, Duggan C, Stoffers J, Huband N, Ferriter M, Lieb K. (2010) S08-01 – Cochrane reviews of pharmacological and psychological interventions for antisocial personality disorder (ASPD). *European Psychiatry*. 25:S1; 90.
15. Timbrell, S., & Thompson, N. Saleem, Y., **Khalifa, N.** (2010). A carer in forensic psychiatry. Student BMJ (in press).
16. Resnick, L., & **Khalifa, N.** (2010). Is the patient your enemy? BMJ rapid response to Al Khalisi. The perils of working as a doctor in Baghdad. *BMJ* 2010; 341: c4043.
17. Varlamov, A., **Khalifa, N.**, Liddle, P., Duggan, C. & Howard, R. (2011). Cortical correlates of impaired self-regulation in personality disordered patients with traits of psychopathy. *Journal of Personality Disorder*, 25 (1), 75.
18. Gibbon S, Völlm BA, Duggan C, **Khalifa N**, Stoffers J, Huband N, Ferriter M, Lieb K. (2011). Pharmacological and psychological interventions for antisocial personality disorder – results of two Cochrane reviews. *European Psychiatry*, 4 (1), 48-54.

19. He, Z., Cassaday, H., Howard, R., **Khalifa, N.**, & Bonardi, C. (2011) The normal inhibition of stimulus-stimulus associations is impaired in personality disorder. *Quarterly Journal of Experimental Psychology*, 4 (12), 2334-51.
20. **Khalifa, N.**, Lumsden, J., Duggan, C. & Howard, R. The relationship between childhood conduct disorder and adult antisocial behaviour is partially mediated by early onset alcohol abuse. *Personality Disorder: Theory, Research and Treatment* (in press).
21. Howard, R., **Khalifa, N.**, Duggan, C., & Lumsden, J. (2012). *Are patients deemed "dangerous and severely personality disordered" different from other personality disordered patients detained in forensic settings?* *Criminal Behaviour and Mental Health*, 22 (1), 65-78.