

Gallagher, Hugh Colin (2012) In the loop: a social network approach to the willingness to communicate in the L2 (L2 WTC). PhD thesis, University of Nottingham.

**Access from the University of Nottingham repository:**

[http://eprints.nottingham.ac.uk/12407/1/PRINT\\_VERSION\\_FINAL\\_FULL\\_THESIS\\_word\\_2007\\_REVISIED\\_2.pdf](http://eprints.nottingham.ac.uk/12407/1/PRINT_VERSION_FINAL_FULL_THESIS_word_2007_REVISIED_2.pdf)

**Copyright and reuse:**

The Nottingham ePrints service makes this work by researchers of the University of Nottingham available open access under the following conditions.

- Copyright and all moral rights to the version of the paper presented here belong to the individual author(s) and/or other copyright owners.
- To the extent reasonable and practicable the material made available in Nottingham ePrints has been checked for eligibility before being made available.
- Copies of full items can be used for personal research or study, educational, or not-for-profit purposes without prior permission or charge provided that the authors, title and full bibliographic details are credited, a hyperlink and/or URL is given for the original metadata page and the content is not changed in any way.
- Quotations or similar reproductions must be sufficiently acknowledged.

Please see our full end user licence at:

[http://eprints.nottingham.ac.uk/end\\_user\\_agreement.pdf](http://eprints.nottingham.ac.uk/end_user_agreement.pdf)

**A note on versions:**

The version presented here may differ from the published version or from the version of record. If you wish to cite this item you are advised to consult the publisher's version. Please see the repository url above for details on accessing the published version and note that access may require a subscription.

For more information, please contact [eprints@nottingham.ac.uk](mailto:eprints@nottingham.ac.uk)



**School of English Studies**

**In the loop:  
A social network approach to the willingness to  
communicate in the L2 (L2 WTC)**

*by*

**H. Colin Gallagher**

Thesis submitted to the University of Nottingham for  
the degree of Doctor of Philosophy

June 2012

*Dedicated to Mom, Shaun, Jake, and Katie*

*In memory of Dad, Karen, and Tim*

# Contents

<b>Abstract</b> .....	<b>iv</b>
<b>Acknowledgments</b> .....	<b>iv</b>
<b>Chapter 1. Introduction</b> .....	<b>1</b>
1.1. Background .....	3
1.2. Aims.....	7
1.3. Significance .....	9
1.4. Limitations.....	10
1.5. Organization.....	12
<b>Chapter 2. Social network analysis and a network approach to L2 learning and use</b> .....	<b>14</b>
2.1. Overview .....	14
2.2. Historical development and key concepts.....	21
2.3. Current state of network analysis.....	28
2.4. Review of social network studies of language .....	49
2.5. Conclusion: Towards a network approach to L2 learning and use .....	63
<b>Chapter 3. Willingness to communication in the second language (L2 WTC)</b> .....	<b>68</b>
3.1. Introduction .....	68
3.2. L2 WTC as disposition: The psychological antecedent strand .....	70
3.3. L2 WTC as participation: The social co-construction strand.....	88
3.4. Culture, networks, and L2 WTC.....	108
3.5. Conclusion .....	110
<b>Chapter 4. L2 WTC and cross-cultural adaptation of sojourners</b> .....	<b>112</b>
4.1. Introduction .....	112
4.2. Methods.....	132
4.3. Results and Discussion .....	136
4.4. Conclusion.....	143
<b>Chapter 5. Social network analysis and L2 WTC within a community of learners</b> .....	<b>145</b>
5.1. Introduction .....	145
5.2. Methods.....	173
5.3. Results.....	186
5.4. Discussion.....	201
5.5. Summary .....	213

<b>Chapter 6. Conclusion.....</b>	<b>215</b>
6.1. Summary .....	216
6.2. Implications.....	221
6.3. Limitations.....	232
6.4. Future directions.....	236
<b>Appendices.....</b>	<b>241</b>
Appendix A: Glossary of network terms .....	241
Appendix B: Issues with network data.....	243
Appendix C: CATREGGE and REGGE algorithms.....	248
Appendix D: Permutation-based analysis tools.....	251
Appendix E. Scale Items .....	255
<b>References.....</b>	<b>261</b>

## Abstract

Despite the conceptual importance of investigating the social context(s) in which second-language (L2) learning and use take place, the decade-old “social turn” within the field of second-language acquisition (SLA) has yet to produce a “parsimonious system of valid and generalizable parameters to describe contextual characteristics” (Dörnyei, 2009a, p. 238). Accordingly, investigating social network structure has recently been suggested as a general approach to examining the link between person and environment (Beckner, *et al.*, 2009). In the current thesis, I offer a network approach in which second-language (L2) learning and use is regarded both as purposeful and as constrained by one’s social relationships. Subsequently, in a first-of-its-kind study within SLA, I apply *social network analysis* – a diverse array of formally-defined measures of social position and other socio-structural features – to conceptualize and empirically test the relationship between social structure and the *willingness to communicate in the L2* (L2 WTC), defined as the “readiness to enter into discourse at a particular time with a specific person or persons, using a L2” (MacIntyre, *et al.*, 1998, p. 547). In a study of Chinese-speaking international students at a British university, trait-like L2 WTC is found to predict cross-cultural adjustment, suggesting the role of actively engaging with one’s new cultural surroundings in establishing an adaptive person-environment fit. Subsequently, in the first study to apply modern, graph-theoretic notions of social position to a network of L2 learners, a significant relationship is found between various notions of structural position among a network of international English-for-Academic-Purposes students, and dispositional L2 WTC. Overall, the results support L2 WTC as both purposeful and constrained, learned from one’s past interactions, yet pushing the individual to take advantage of opportunities to communicate in the L2. Implications, limitations, and future directions of a social network approach to L2 learning and use are also discussed.

## Acknowledgments

This thesis would not have been possible without the help and support of many people. In particular, I would like to thank the following individuals. First, I would like to thank my family and Conny for their constant support which kept me grounded at the high points, and brought me through the low ones. I also wish to express my gratitude to my supervisor, Professor Zoltán Dörnyei, whose trustworthy guidance always kept me on the right path. I wish to thank my friends both in England and in the US, whose companionship and encouragement made the effort all the more worthwhile.

Furthermore, I would like to thank the many individuals who offered assistance large and small. In particular, I would like to thank Professor Jean-Marc Dewaele and Dr Kathy Conklin for taking the time to serve as examiners; their insights and guidance contributed greatly to this work. I would also like to express my gratitude to David Mann and the teachers at the Language Centre at Nottingham Trent University for their assistance with data collection; their helpfulness was a turning point in this thesis. I would like to thank Kentucky Refugee Ministries for allowing me to observe; although my time there was not reported in this thesis, I learned and grew a great deal as a researcher and person. Further gratitude goes to numerous colleagues within the School of English Studies and beyond, including Dr Tatsuya Taguchi, Professor Norbert Schmitt, Dr Phoebe Lin, Dr Kevin Harvey and many others for help with piloting, participant recruitment and translation, data collection, data analysis, and the opportunity to teach. Special thanks goes to those who helped in proofreading, including Martin, Conny, Paul, Sam, and Zalfa. Finally, I wish to express my gratitude to the many language learners who participated in my studies, sharing with me their experiences and their time.

# Chapter 1

## Introduction

“Well-connected” “In the loop” “In the know” “In the thick of it” “On the same wavelength”

“Sheltered” “Behind the times” “Out of sync” “Head in the clouds” “Get with the program”

Our language is replete with ways of signaling and recounting our involvement with the social world around us. It is through language that we share our intentions, actions, and ways of understanding with other people in order to achieve what we deem important, and to function with others on a day to day basis. As one would expect, therefore, the task of engaging with a social world that is mediated by a relatively new and unfamiliar language is a daunting one, especially to the sojourner confronted with the basic task of functioning within a culture that he or she is still discovering. Yet, unkindly, it is the extent to which the language learner faces this unfamiliarity head-on that governs how quickly he or she can move past it to establish a proper social footing, hopefully even better than before.

Reflecting on my own involvement with French as a foreign language in a high school in the Mid-America, there was a time when I seemingly fit the bill as an engaged learner. Looking back even now, however, the well-researched reasons for learning a second language – such as general feelings of affinity for French speakers or the pragmatic value of French – rang hollow in that decidedly un-French part of the world. I could only assume a great number of French speakers to be quality people, and imagined France to be – in an abstract sense – probably an exciting and fulfilling place to live. However, these surely could not have been the reasons I initiated and persisted in learning French over seven years of formal study. Indeed, in comparison to the grandeur of French Culture, what was pushing me towards studying French seemed relatively mundane: a cachet of



French dictionaries from my sister; expectations about the class from my brother; humor and praise from a charismatic teacher; camaraderie and friendly competition from classmates; and a temporary reprieve from a class bully who took Spanish.

Striking to me is how these storylines are fundamentally *requires* others to enact: following in the footsteps of family members; conspicuous achievement and cut-throat competition with classmates for high marks; jocular in-joking among cliques of high-school boys. While I may have sat at some complexly unique interaction of these themes, and used them in creative ways to realize goals I saw as important, these notions of my second-language self were not “completely detached from reality” (Dörnyei, 2009b, p. 12). Instead, the reality in which I took part was a socially constructed one: my goals, motives and intentions were set in relation to others. I achieved these goals – either cooperatively or competitively, but always interdependently – through my interactions with family members, teachers, classmates, and other social relations.

Nonetheless, while our language – whether through idiomatic phrasing or personal narrative – permits us to capture in some adequate way the interdependencies of social life, our social-scientific methods have lagged well behind in this regard. Just like language learners themselves, social scientists have long been trying to understand our social world in pursuit of a (scholarly) goal. Indeed, such a view of language learning as heavily influenced by, or indeed inseparable from, the social context in which it occurs has long been the overarching pursuit of social scientists examining second-language (L2) acquisition. However, despite this focus, actual analysis of the social environment has remained problematic. How does one conceptualize the individual within his or her social environment? How can we measure or otherwise evaluate it? What are the particular mechanisms by which it impacts a particular individual’s attitudes, beliefs, and actions?

One approach that may contribute to a more systematic and formally-defined conceptualization of the social world is the notion of *social networks*. As a theoretical paradigm, a

network approach conceptualizes behavior, attitudes, and identity as relationally constructed and maintained, fundamentally challenging traditional, category-based normative explanations within the social sciences. As a methodological approach, *social network analysis* offers a diverse array of formally-defined measures of social position, social subgroups, and paths of social influence among interconnected actors. It is thus uniquely suited to quantitative empirical investigations of the structural and relational aspects of human behavior. Given this general applicability to describing the social world, social network analysis is decisively cross-disciplinary, employed by researchers across the spectrum of social sciences, including sociology (Lin, 2001), organizational studies (Borgatti & Foster, 2003), and even public health (Luke & Harris, 2007).

However, social network analysis is not simply just another set of methods for describing the social environment. Rather, social network analysis is a disperse, fast-evolving field, at times internally conflicted, incorporating both rationalist and structuralist views of social context as composed of social relations. Nevertheless, the field remains retains a fundamental set of assumptions which entail a marked shift away from traditional social psychology, and holds considerable promise for achieving a more satisfactory conceptualization of the social, relational context of language learning. Consequently, a network approach to L2 learning and use is the central concern of the current thesis.

## **1.1. Background**

The impact of social context on L2 learning has served as the defining feature of the field of second-language (L2) motivation since its inception in the pioneering work of Wallace Lambert and Robert Gardner, who were among the first to systematically address the now seemingly obvious argument that one's attitudes towards the target language group would affect one's motivation to learn the target language itself. This basic observation eventually led to the highly influential *socio-educational model* (Gardner, 1985), which established the prevalence of the notion of *integrative motivation* – the impetus to learn the L2 out of a desire for relatedness with members of the target

language group, and positive attitudes towards the learning situation. At the heart of this model and the first period of L2 motivation research more generally was an overriding focus on various individual difference factors in language learners which contribute to various linguistic and nonlinguistic outcomes, including ultimate L2 acquisition, and shifts in intergroup attitudes.<sup>1</sup>

However, the limitations of Gardner's model lie in the fact that it focuses primarily on motivational constructs arising out of the macrosociological context, with insufficient attention paid towards important influences situated within the language classroom and other more 'micro' settings (Dörnyei, 1994). As a result, the widespread application of the socio-educational model to various "sociocultural milieu" has been problematic. For example, the notion of integrativeness relies on the assumption that students have enough firsthand experience with the target language group to form sufficiently-developed attitudes towards its members, a questionable premise in many foreign-language classroom settings (e.g., Dörnyei, *et al.*, 2006). Furthermore, a number of researchers have uncovered the relative deficiency of integrative motivation in predicting language learning within certain sociocultural contexts marked by intergroup segregation and tension (e.g., Abu-Rabia, 1996; Oller, *et al.*, 1977) and great physical and cultural distance between the L1 and L2 cultures (Chen *et al.*, 2005).

It has therefore been generally accepted that motivational processes linked to the instructional setting itself can drive language learning in the absence of integrative orientation towards the target language group (Crookes & Schmidt, 1991; Dörnyei, 1994; Oxford & Shearin, 1994). Accompanying this conceptual turn was an "educational shift" in L2 motivation research during the 1990s, in which investigators re-directed their attention towards situated contexts in which language learning takes place, in particular L2 learning tasks within the classroom context (see

---

<sup>1</sup> Dörnyei (2005; 2011) divides the history of L2 motivation research into three periods: the social psychological period dominated by Gardner's (1985) model; the cognitive-situated period in which specific learning contexts (i.e., the L2 classroom) were the main focus, and; the process-oriented period in which researchers began to emphasize the temporal nature of motivation.

Dörnyei, 2011 for review). This was accompanied by an expansion of the conceptual inventory of motivational frameworks, borrowed from the wider motivation literature within educational psychology, including self-efficacy (e.g., Bandura, 1997), self-determination (Deci & Ryan, 1985), learner autonomy (e.g., Dickinson, 1995) and a host of others. One goal of this shift was to render motivational frameworks more useful for teachers, thereby empowering them to make beneficial changes within the classroom (Dörnyei, 1994; Oxford & Shearin, 1994). This acknowledgment of the role of instructors in instilling and sustaining motivation was part of a more general affirmation of individuals as active agents within the learning context.

Meanwhile, this narrowing focus on situated L2 use within the classroom through an extended array of motivational frameworks complemented Firth and Wagner's (1997) call for an expansion of methods by which to conceptualize language as a social construct, in line with their view of language learning as occurring within "interactive encounters." Together, these approaches generally converged with the longstanding emphasis on language learning as it occurs through input and interaction (Long, 1981; 1996; Gass, 1997). However, the extent to which these approaches complement versus compete with a traditional cognitive perspective has been one of the central debates within SLA over the past 15 years (Firth & Wagner, 2007; Larsen-Freeman, 2007a).

More recently, a focus on social interaction lies at the core of the recent shift towards the dynamic systems perspective on L2 acquisition. In such a view, language is seen as continuously evolving and changing, both within the individual and among a speech community. Language is therefore not a fixed phenomenon, but derived from individuals' interactions with each other:

Forms in language are therefore to be seen as epiphenomena of interaction. They are emergent stabilities or attractor states in the dynamic system, where the state of a complex system refers to current patterns of behaviour, not to stasis. (Cameron & Larsen-Freeman, 2007, p. 230).

Yet, the subsequent proliferation of methods for investigating micro-level processes of language learning and use has yet to produce a “parsimonious system of valid and generalizable parameters to describe contextual characteristics” (Dörnyei, 2009a, p. 238), leaving a considerable amount of theoretical work to be done. Larsen-Freeman (2007b) maintains that the analytical challenge for SLA researchers in relating the agent to the environment becomes one of “cultivating a dialectical relation between parts and wholes in order to identify the appropriate functional units of analysis, which is of course something that is likely to require ongoing redefinition, depending on the inquiry” (p. 37). However, while Dörnyei (2009a) has asserted that the first step in this effort lies in developing new, exploratory qualitative research methods, computational modeling of social networks, broadly defined, seems poised to enter the discussion over methodological advances as a possible heir to the quantitative tradition within L2 motivation research.

This insertion of social networks into the nascent dynamic systems approach to L2 acquisition comes by way of the “Five Graces Group” (Beckner, *et al.*, 2009), who attest to the language’s inherently social function in conceiving of it as a *complex adaptive system*. Such a perspective on language involves several basic premises that contradict a generativist approach. First, language is rooted in the continual interactions of a community of agents. Second, language is adaptive in the sense that past and present interactions serve to shape future behavior. Third, speakers’ behavior results from the intersection of a range of factors, such as cognitive-perceptual limitations and social motivation. Fourth, language is derived from joint intentions and experiences among interacting individuals. In light of these properties, they uphold the importance of looking at social network structure in order to deduce the social mechanisms which impact behavior, such as the emergence of community norms. They therefore maintain that “[a]n understanding of the social network structure that underlie linguistic interaction remains an important goal for the study of language acquisition and change” (p. 17). The current thesis shares in this goal.

It is in this context that the *willingness to communicate in the second language* (L2 WTC) takes on particular relevance, in that it is informatively incomplete. Conceived of as the “readiness to enter into discourse at a particular time with a specific person or persons, using a L2” (MacIntyre, *et al.*, 1998, p. 547), L2 WTC is regarded as the fluctuating intention to use the L2, *given the opportunity*, that results from an array of individual, contextual, and situational factors that interact either to elicit a psychological readiness to communicate, or to forestall it. MacIntyre and colleagues assert that instilling such a willingness to use the L2 should be the ultimate goal of any language program.

Nonetheless, the notion of opportunities to use the L2 has not been systematically addressed; it has either been assumed to be a blanket function of the general (instructional) setting, held constant for experimental or observational purposes, or has gone unexplained in terms of the underlying social structure that constrains one’s access to regular interactions. The result has been a remaining conceptual gap between the L2 WTC concept and how individuals use the L2 to accomplish their aims fundamentally with and through one another, whether that be cooperatively or competitively. To borrow Larsen-Freeman’s (2007b) phrasing, the dialectal relationship between the part – the individual’s L2 WTC – and the whole – the joint communicative activity of the community – remains uncultivated. The current thesis aims to address this gap.

## **1.2. Aims**

As the Five Graces Group point out, computational modeling of social networks is filled with uncertainty regarding certain relevant network forces which help to shape the configuration of social networks (see Newman & Park, 2003). Indeed, while the general idea of L2 use as socially influenced (if not socially *derived*; see Tomasello, *et al.*, 2005) is itself widely accepted, not readily apparent are the precise mechanisms by which the wider mesh of social relationships impact language behavior. As such, there remains a pressing need for the investigation of empirical networks to aid in the formulation of computational models. The Five Graces Group thus “envisage a future in which

formal modeling and empirical data collection mutually guide one another” (Beckner, *et al.*, 2009, p. 11).

In light of these considerations, the purpose of the current thesis is to investigate the relationship between social network structure and the intention to use the L2, as conceived of in terms of L2 WTC. The first task of the thesis is therefore to outline a general social network approach to language learning and use. Offered is a framework of social network concepts which can be incorporated into a trait-like notion of L2 WTC. In doing so, the L2 WTC concept becomes an essential component of one’s understanding of how the individual establishes an adaptive fit his or her social environment. However, at the same, the notion of L2 WTC itself is revised, becoming less individual and more social in character, with an increasing focus on how the individual comes to share in the intentions of others, through use the L2, in order to meet personal goals. However, crucially, I do not intend to look at the specific personal motivations for using the L2 with a given person on a given occasion, assuming these reasons to be varied and numerous. Rather, I aim to look the *interdependence* of individuals in fulfilling the motive to communicate, and the extent to which this interdependence crosses cultural boundaries, thereby necessitating use of the L2.

Following the task of outlining the theoretical underpinning of a network approach to L2 WTC, I offer two empirical studies intended to support key aspects of a network approach to L2 learning and use. In all, my empirical aims are as follows:

- To examine the role of L2 WTC in the cross-cultural adaptation process of sojourners.
- To conceptualize the opportunity for social interaction using various network concepts
- To investigate the impact of these network features on L2 WTC and perceived L2 competence.

### 1.3. Significance

The primary significance of the current thesis resides in its first-of-a-kind application of modern social network analysis to the study of L2 motivation, intention, and use. While certain rudimentary forms of social network analysis have been used previously within studies of sociolinguistic variation (e.g., Milroy & Milroy, 1978; see Section 2.4.1), and personal social networks have been used as a conceptual or descriptive device within studies of L2 use on a more frequent basis (e.g., Kurata, 2011; see Section 2.4.2), this thesis contains the first-ever study within SLA to apply modern, graph-theoretic notions of social position within a community network structure<sup>2</sup> in order to conduct hypothesis-testing.

Given the emphasis on social network structure (Beckner, *et al.*, 2009), as well as a call for new methodologies to investigate language as a complex adaptive system (Dörnyei, 2009a), the network approach advanced in this thesis comes at a crucial time in SLA. It offers a needed introduction to a concept that at once possesses intuitive appeal, but is also accompanied by seemingly arcane computational methods. Though the Five Graces Group were likely not referring specifically to *network* studies in their call for empirical data collection to complement computational modeling, such studies may directly inform modeling, and are thus particularly significant. Simultaneously, social network analysis' roots in anthropological and organizational studies also make it highly amenable to incorporation with ethnographic and other qualitative approaches. Introduction of social network analysis into the general SLA research agenda therefore represents an important methodological step forward that complements likewise important theoretical advances within the field.

---

<sup>2</sup> "Community network structure" is more commonly referred to as a "sociocentric" approach, in which the researcher examines a bounded network as whole, rather than the personal networks (also referred to as "ego-centric" or "first-order" networks) surrounding each individual.



On a more practical level, the significance of this thesis lies in its treatment of the *interdependence* of L2 use. With communication being fundamentally an activity conducted *between* individuals, the interpersonal regularities in communication which build up over time (e.g., friendships) give rise to social systems which will likely display some form of status hierarchies, role differentiation, sub-communities, and so on. As a result of structural differences, these systems may display disparities in opportunities to use the L2, with a matching potential for likewise disparate linguistic and nonlinguistic outcomes. In other words, a network approach to L2 learning and use directly questions whether learners have equal opportunities to succeed in their efforts to grow and learn.

Such a focus on structure and development present at least one significant issue to language teachers: in instilling L2 WTC in one student, what is the effect on other students? To an extent, this issue was a central concern beginning with the educational shift in L2 motivation research, with an emphasis placed on the formation of group norms and the significance of community building in the classroom (Ehrman & Dörnyei, 1998). However, the question which remains is the extent to which instructors should seek to maximize students' L2 WTC for use in *competitive* social spheres, or strive to optimize it for participation in more *cooperative* forums. The current thesis frames this issue, but offers no easy answers. In pushing certain students to seize every opportunity to use the L2, the teacher may be constraining other students' opportunities. Alternatively, in stressing equal speaking rights, one might not be properly socializing the student to compete in comparatively cutthroat settings.

#### **1.4. Limitations**

The current thesis possesses a number of important limitations. First, while language learners are assumed to act in pursuit of self-determined goals, I accept, rather than directly address, Ushioda's (2009) notion of the "person-in context," in which the individual is viewed as a "thinking, feeling human being, with an identity, a personality, a unique history and background, a

person with goals, motives and intention” (p. 220). Instead of looking specifically at participants’ various personal aims, I focus on the system of social relations that permit individuals to realize those aims *interdependently*. Out of practical concerns, however, I have had to limit my focus to international students studying in the United Kingdom, thereby restricting my empirical gaze to the accomplishment of goals within an academic context.

Second, in focusing on social structure, I do not attend directly to the situated micro-behavioral processes that, once regularized, compose social structure. Instead, such a micro-level focus is the purview of investigations of situated L2 WTC. While such a perspective is directly relevant to a network approach to the study of L2 use, it remains thoroughly focused purely on interpersonal interaction as it actually happens. By contrast, a network approach is most useful to delineating the interdependence of these interactions among a group of individuals.

Furthermore, the studies are cross-sectional. While changes over time are important to a network treatment of the intentional agent (and, notably, to the ascendant dynamic systems perspective), the present studies share the common limitation of many network studies in only being able to allude to the dynamic processes of social exchange and social learning that occur among interacting individuals across time. In all, therefore, I consider the current thesis as walking in order to run – a modest first step in conceptualizing the agent-environment dyad. While fully acknowledging that it falls well short of an as-yet realized dynamic systems ideal, it hopefully demonstrates a crucial means by which such an ideal might be better approximated in the near term. Indeed, the current thesis should be judged in part on the extent to which it demonstrates social network analysis to be a useful methodological tool that is worth the considerable effort of engaging with its often arcane computational terminology and techniques.

## 1.5. Organization

In Chapter 2, I provide an overview of social network analysis. As part, I review its main historical development and most prominent concepts, including centrality, cohesion, and role equivalence. I then review its previous application to the study of individual linguistic variation and behavior. I set forth the task of incorporating social network analysis into a theory of purposeful L2 use in the face of an opportunity.

In Chapter 3, I review the L2 WTC model and related empirical studies, looking at both trait-like and situated conceptualizations. Within these studies, two general strands of research can be detected: an earlier strand of studies which focus on psychological antecedents of trait-like notion of L2 WTC, and a subsequent strand of studies which center on the cyclical relationship between L2 WTC and the co-construction of social reality between individuals.

In Chapter 4, I look closer at the notion of ‘opportunity’ within the L2 WTC model by relating it to the ecological concept of affordance (Gibson, 1986) and person-environment fit (e.g., Lazarus & Folkman, 1984). I take the *culture shock* experienced by sojourners migrating to a new culture to be the extreme and sudden emotional and cognitive response to a likewise drastic shift in personal context. As part of the adaptation process, both the individual and his/her immediate environment continuously influence one another in order to achieve a better fit. L2 WTC is seen as a potential component of an active, problem-focused orientation toward dealing with this extreme uncertainty and anxiety. In support, I present a quantitative study examining the role of L2 WTC in the process of adaptation by Chinese-speaking international students studying at a British university.

Chapter 5 offers an empirical network study of a cohort of international students studying English-for-Academic-Purposes in order to gain entry to a British university. Language learning is assumed to be fundamentally discrete, relational, and interdependent process, in which interaction between two individuals can impact the interactions between other nearby individuals in various

ways. Trait-like L2 WTC is conceptualized as a changeable, learned disposition that exists in relation to the social context, rather than independent of it. The relationship between L2 WTC and various network features is examined by means of a sociocentric (whole network) study of a cohort of international students studying English-for-Academic-Purposes.

In the sixth and concluding Chapter, I review the major findings of the studies, discuss their wider implications, and offer further recommendations for a network approach to L2 learning and use.

## Chapter 2

# Social network analysis and a network approach to L2 learning and use

### 2.1. Overview

In this chapter, I provide an introduction to social network analysis and its primary assumptions, strengths and weaknesses. Following this, I review the historical development of social network analysis, highlighting various major contributions. Subsequently, I review the structural concepts of centrality, cohesion, and role equivalence that feature prominently in this thesis (see Chapter 5). I then discuss the tenuous relationship between social network approaches and psychological theories in more depth, emphasizing underdeveloped accounts of agency which have often accompanied network analysis, and efforts made to compensate for this deficiency. Next, I review the application of network theory to language studies, including sociolinguistic variation and L2 learning and use. Lastly, I set forth the task of incorporating social network analysis into a theory of purposeful L2 use in the face of an opportunity.

Throughout this chapter, a central theme is the classical debate between agency and structure, with social network analysis traditionally favoring explanations of the latter to the detriment of the former. Indeed, network studies of language behavior have largely been no exception, demonstrating the same conceptual tension. Nonetheless, in seeking a more adequate treatment of human agency, a number of network analysts have moved towards viewing structure not as an objective, inescapable force, but as a site of *opportunity* over which the individual may exercise a degree of control, depending on his/her position. It is therefore with notions of structural opportunity in mind that I argue for social network analysis as a valuable methodological advance within investigations of L2 use.

### 2.1.1. What is a social network?

A social network can refer to a variety of concepts. On the level of the individual, a social network is our web of interpersonal ties. However, more generally, a social network is a mesh of interconnected *social actors*. Social actors can be any social entity, including individuals, groups, organizations, nations, and so on. However, social network analysis takes the relation between two such actors as the most basic unit of analysis, *not* the actors themselves. The primary concern of social network analysis is therefore the structure that results from the interlinking nature of social ties, not the psychological processes within the individual. As will be discussed in depth in this chapter, this focus on system has often come at the expense of any adequately sophisticated treatment of the individual actor (Robins & Kashima, 2008).

**Table 2.1.** Typology of ties studied in network analysis (adapted from Borgatti, *et al.*, 2009, p. 894)

<i>Similarities</i>			<i>Social Relations</i>			<i>Interactions</i>
<i>Location</i>	<i>Member-ship</i>	<i>Attributes</i>	<i>Kinship/Role relation</i>	<i>Affective</i>	<i>Cognitive</i>	
e.g., physical proximity	e.g., same event, same class	e.g., same gender, same ethnicity	e.g., parent of, relative of, friend of, co-worker of	e.g., likes, dislikes, trusts	e.g., knows, judges as smart	e.g., talks to, gives advice to, helps

Social relations themselves can be characterized in terms of similarities, role relations, affective and cognitive states, and interactions (see Table 2.1). Therefore, network theorists and researchers generally assume there to be numerous possible social networks that may impact various behaviors in different ways, rather than the existence of a single, underlying network. Various network conceptualizations are used to infer the “flows” of symbolic and material resources (e.g., information, social support, goods, contagion, etc.) between actors (Borgatti, *et al.*, 2009).

Wasserman and Faust (1994) offer a set of basic assumptions that constitutes a social network approach:

- Actors are interdependent, not autonomous.
- The interrelationships among actors form the framework across which tangible resources (e.g., money, information) and symbolic resources (e.g., emotional support) flow.
- Network structure both constrains and enables the actions of individuals.
- Network structure is constituted by persistent patterns of interrelationships.

Beyond these basic assumptions, however, there is little to bind together network approaches into a single, cohesive theory. Social network analysis is not a single, unified theoretical framework that outlines a set of laws or propositions, or associations. Instead, there exists a diverse set of methodological approaches for analyzing structured relations. Social network analysis has been described as “a broad strategy for investigating social structure” (Emirbayer & Goodwin, 1994, p. 1414). Burt (1980) describes network analysis as a “loose federation of approaches” (p. 79) rather than a predictive social theory. As Barnes (1972, cited in Burt, 1980) aptly notes, the literature on social network analysis represents “a terminological jungle in which any newcomer may plant a tree” (p. 79) – an insight which has retained much of its validity over the past 40 years. Therefore, one should not speak of a singular network theory, but of a heterogeneous array of theories in which network concepts are intertwined with mathematical and social psychological theories (Kilduff & Tsai, 2003).

### **2.1.2. Some initial strengths and weaknesses**

Granovetter (1985) maintains that the key theoretical strength of a social network approach lies in its ability to address the issue of *embeddedness*. By this, Granovetter means that networks permit an account of human action that is neither ‘over-’ nor ‘undersocialized.’ An oversocialized

account views the individual as acting in lock-step accordance with internalized norms and values that correspond with his or her various social categories. Many psychologists and sociologists have made the assumption of *behavioral invariance* – namely, that individuals fundamentally act in more-or-less consistent ways across situations, with the important differences existing *between* individuals (Simon, 1990). By contrast, an undersocialized perspective holds individuals as all basically the same, reacting in a uniformly rational, self-interested manner to different situations.

However, despite their drastic differences, the two positions hold one key commonality. As Granovetter (1985) notes:

[D]espite the apparent contrast between under- and oversocialized views, we should note an irony of great theoretical importance: both have in common a conception of action and decision carried out by atomized actors. In the undersocialized account, atomization results from narrow utilitarian pursuit of self-interest; in the oversocialized one, from the fact that behavioral patterns have been internalized and ongoing social relations thus have only peripheral effects on behavior. That the internalized rules of behavior are social in origin does not differentiate this argument decisively from a utilitarian one, in which the social source of utility functions is left open, leaving room for behavior guided entirely by consensually determined norms and values – as in the oversocialized view. Under- and oversocialized resolutions of the problem of order thus merge in their atomization of actors from immediate social context. (p. 485)

Both conceptualizations largely sidestep the issue of ‘embeddedness’ – or the way in which one’s place within a network of regularly interacting actors impacts on social exchange. By contrast, the development of social structures requires an explanation of individual behavior as continually shaping, and being shaped by, structure (Giddens, 1979). Sufficiently sophisticated accounts of



cultural influence thus treat structure as an ongoing process of re-construction of trust and other emergent properties, not a static 'once-for-all' determiner of behavior (Granovetter, 1985).

In permitting such a balanced account of human action, social network analysis contributes significantly to explanations of human behavior that bridge the "micro-macro gap," or the conceptual chasm between explanations of microsociological and macrosociological social phenomena (Galaskiewicz & Wasserman, 1994). At a microsociological level, social actors are individuals linked to one another through a mesh of interrelations, forming dyads, triads, and subgroups. "Weak ties" (relationships of low intensity) link these subgroups together into a larger social structure (Granovetter, 1973). Smaller structures are thus embedded within larger structures, such as groups, organizations, corporations, nations, and so forth. Social network analysis thus demonstrates that small-scale social networks are situated within social, economic, political, and other institutional spheres (Galaskiewicz & Wasserman, 1994). Consequently, it permits researchers to examine how an attitudinal or behavioral trend can begin with one individual, spread to other groups via interpersonal relationships that span group boundaries, and continue to diffuse across the network structure until it becomes a macrosociological trend, potentially resulting in social change. In turn, these large-scale forces filter back down to the level of the individual, impacting his or her own attitudes and behavior. Social network analysis is therefore capable of describing how individuals' attitudes and behaviors both influence, and are influenced by, macro-level structures and forces.

However, taking a network perspective comes with some significant trade-offs in terms of both theoretical stance and methodological approach. For reasons discussed below (see Section 2.3.3), social network analysis has diverged considerably from theories of social psychology and the powerful explanations of social behavior that they provide. Owing partially to a viewpoint that subjective factors are not the independently-held properties of individuals, social network analysis as it has often been applied in empirical investigations has suffered from an under-theorized account

of the individual agent, which network theory often treats as a mere node networked to other nodes (Robins & Kashima, 2008). As Emirbayer and Goodwin (1994) argue:

Network analysis all too often denies in practice the crucial notion that social structure, culture, and human agency presuppose one another; it either neglects or inadequately conceptualizes the crucial dimension of subjective meaning and motivation – including the *normative commitments* of actors – and thereby fails to show exactly how it is that intentional, creative human action serves in part to constitute those very social networks that so powerfully constrain actors in turn. (p. 1413; emphases original)

In a similar vein, Stryker (1977) criticizes social exchange theories (which prominently use social network analysis to explain action) for the “emptiness” of their simplistic and abstract notion of objective value of the resources which flow through social structure. He also notes that explanations involving subjective “perceptions” of objective value are similarly unsatisfactory. Stryker favors “a view of man [sic] as active participant rather than as passive recipient, as (partial) shaper of his destiny rather than totally responsive to societal demands” (1977, p. 151).

A further limitation of a network approach is its lack of a complex explanation for the *content* of attitudes. Mizruchi (1994) maintains that network analysis provides methods to describe the diffusion of a given attitude, belief, or behavior across a population, but not what that attitude, belief, behavior is to begin with. It can therefore explain the likelihood that an individual will have an attitude only if the preferences of his/her social referents are known beforehand. It cannot explain the historical processes – such as prior environments of socialization and the occurrence of exogenous events – involved in the initial formulation of those attitudes. Network analysis must therefore accompany various other historical and ethnographic methods in order to provide a fuller description of the substantive issue under investigation, such as that seen in Emirbayer & Goodwin (1994).

Ultimately, it is the charges of determinism leveled against network analysis that are the most problematic for its application to L2 learning and use. The pervasive viewpoint within 'social' SLA (e.g., Firth & Wagner, 1997) and L2 motivation studies is that individuals use language to effect change on their environment and accomplish personal aims. A robust account of agency is thus essential, especially given the pedagogical focus of these fields. Consequently, the lack of any wide-spread application of social network approach to the social psychology of language is understandable. However, as already mentioned and as discussed below, network approaches, while often initially prone to deterministic explanations, may nonetheless be reconciled with notions of agency. The issue of formulating a sufficient account of agency within structure feature prominently throughout this chapter.

### **2.1.3. The “anti-categorical imperative”**

The notion that identities are relationally mediated and maintained, and that decisions are made interdependently, underlies what Emirbayer and Goodwin (1994) call the “anticategorical imperative” of network analysis. According to this principle, human social behavior and processes are seen as originating from their place within a structure of social relations, rather than in the attributes and internalized norms of individual actors. According to Wellman (1988):

People belong to networks as well as to categories. Structural analysts believe that categorical memberships reflect underlying structural relationships, that is, patterned differences in the kinds of resources with which they are linked. (p. 33)

As a result, attributes are generally viewed as outcomes of wider structural processes, rather than as purely independent variables within a causal structure of social phenomena. These attributes include socially constructed variables such as social class, marital status, and even ethnicity and gender, as well as subjective factors relevant to language learning such as attitudes, beliefs, ethnicity, motivational orientations. Network analysts maintain that treating these attributes as

quantifiable properties of the individual strips them of much of their meaning, potentially giving rise to analytical problems, including problems of aggregation (Wellman, 1988). Consequently, the anticategorical imperative lies at odds with traditional perspectives within social psychology of language, and much of social psychology as a whole, which generally mask the socially constituted nature of attitudes, beliefs, and motivational orientations. Instead, these variables are cast as the possessions of independent individuals, and fundamentally explanatory of language acquisition and other social phenomena. In contrast, a network approach to notions such as orientation, motivation, and beliefs raises fundamental questions as to their socially-constituted nature.

## **2.2. Historical development and key concepts**

Freeman (2004) locates the earliest precursors to network analysis within the structuralist thinking that emerged in the 19<sup>th</sup> century with Auguste Comte and Herbert Spencer, which in turn influenced Émile Durkheim and his notions of mechanic and organic solidarity. Common among these early scholars is a perspective that describes society in terms of the social relations among actors. However, it was Georg Simmel who stated this early structural perspective most clearly: “Society exists where a number of individuals enter into interaction” (1908/1950, p. 23). He subsequently constructs his idea for structural inquiry of social life:

A collection of human beings does not become a society because each of them has an objectively determined or subjectively impelling life-content. It becomes a society only when the vitality of these contents attains a form of *reciprocal influence*; only when one individual has an effect, immediate or mediate upon another, is mere spatial aggregation or temporal succession transformed into society. If, therefore, there is to be a science whose subject matter is society and nothing else, it must exclusively investigate these interactions, these kinds and forms of sociation. (pp. 24-5; emphases mine)

As Freeman (2004) maintains, it is Simmel's ideas that form the theoretical foundation of modern social network analysis. It is through direct and indirect interaction that actors exercise influence upon one another. Through this interaction, society is an emergent phenomenon from what was otherwise a mere co-occurrence of individual humans. Therefore, to understand human social behavior requires examination of the system of relationships that link actors directly and indirectly, taking on new properties not explainable in individual terms.

Freeman goes on to list an explicit structuralist viewpoint as the first of four characteristics that are hallmarks of a modern approach to social network analysis. The other three features are: systematic data collection of relationships between specific social actors; graphical representation of this network data; and formulation of mathematical and computational methods for treatment of network data. In this section, I will outline the historical development of modern social network analysis in parallel with some basic terms and concepts which emerged from particular movements, whose theoretical commonality as "network approaches" did not, in some cases, initially bind them into a common field. This will lead into more recent advancements that form the backbone of current network analysis.

### **2.2.1. Sociometry and the sociogram**

The first movement that incorporates all four features of modern network analysis was *sociometry* as developed by Jacob Moreno and his associates Helen Jennings and Paul Lazarsfeld.<sup>3</sup> Moreno defines sociometry as "the mathematical study of psychological properties of populations, the experimental technique of and the results obtained by application of quantitative methods" (1934; cited in Moreno, 1953; pp.15-6). More specifically, sociometry marks the first systematic quantitative approach to studying the interrelationships between members of a social group.

---

<sup>3</sup> Freeman (2004) suspects that these two, especially Jennings, have not been given adequate credit in sociometry's development. Jennings was instrumental in incorporating systematic data collection methods. Likewise, Lazarsfeld – a mathematical sociologist – contributed greatly to the computational models to analyze the data.

In his 1934 book *Who Shall Survive?* (along with an expanded second edition in 1953), Moreno offers an exhaustive description of his approach, theories, and findings. His main focus is on the interconnections within small groups, positing their role in the psychological development of the individual. He takes as his focus the small group as defined by its particular context, which he labels the *social atom*. Moreno offers computational methods to test his hypotheses, such as statistical procedures for determining whether interaction between two people exceeds a level of chance, indicating a “psychological current” that draws two people together, or pushes them away. To do this one must undertake a “thorough investigation of the depth structure of groups” (1953, p. 92).

To obtain this data, Moreno and Jennings developed the *sociometric test*, in which they asked individuals (egos) to name others (alters) who they liked and disliked in the various areas of local life: living, working, studying, and socializing.<sup>4</sup> As a way of systematically representing the data they collected, Moreno and Jennings made what are perhaps sociometry’s most enduring contributions to social network analysis: the *sociogram* and the *sociomatrix*. A sociogram is a systematic graphical representation of a network of  $N$  number of actors in which the links between them are specified (see Figure 2.1). These links can be either *undirected* – indicating the presence of a symmetrical, binary relationship (i.e., either it exists or it does not) between two actors – or *directed* – indicating who-to-whom links (such as levels of attraction and flow of information) which may be weighted in intensity, and asymmetrical between two individuals. Additionally, Moreno makes use of two types of sociograms: *ego-centric* networks, in which there is a focal individual (*ego*) who is surrounded by others (*alters*); and *socio-centric* networks, a group of individuals delineated by some boundary.

---

<sup>4</sup> This method bears striking resemblance to modern-day name generators used to elicit ego-centric network data.

A sociomatrix is an  $N \times N$  matrix that represents these actors' interrelationships (see Figure 2.1) in a format that permits computational analysis of a social network.<sup>5</sup> Like the sociograms they depict, these matrices can accommodate symmetrical, binary relationships ('0' indicates the absence of a link; '1' indicates its presence), or even directed, asymmetrical relational data. In particular, the application of mathematical methods associated with graph theory (Harary, *et al.*, 1965) has been instrumental in the advancement of network analysis.

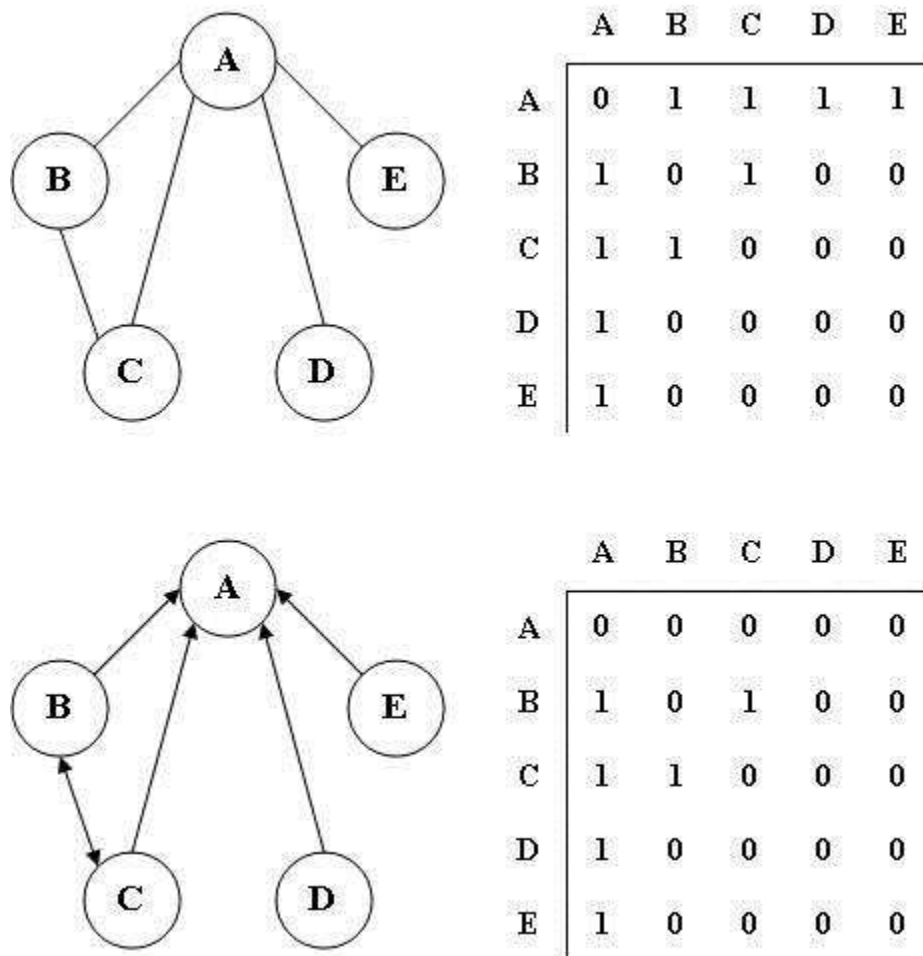

**Figure 2.1.** Undirected (top) and directed (bottom) sociograms, and their corresponding sociomatrices.

<sup>5</sup> While Moreno (1934/1953) does explicitly use the terms “sociogram” and “sociomatrix,” to the best of my knowledge, he is not the originator of the bevy of other important network terminology: directed and undirected; ego-centric and socio-centric; ego and alter. However, the apparent lack of terminology does not negate his obvious depictions of these concepts.

Notably, Moreno (1934/1953) also first used the term and concept of “network” as it is used today. Examining a rash of runaways at a girls’ reformatory school, he observed a “chain within a network” that linked the runaways together. The importance of this observation is that it underscores the notion of social contagion: behaviors starting within an initial grouping of individuals can spread beyond its boundaries via members’ ties to other groupings.

It is little wonder, however, why sociometry eventually faded. First, although sociometry does incorporate computational methods, they are limited. In his cornerstone article, Granovetter (1973) explicitly acknowledges sociometry as the progenitor of network analysis, but attributes its “curiously peripheral” status within sociological theory to a lack of sophisticated measurement and sampling techniques. However, his approach does at least attempt to address crucial issues that modern network analysts have only recently (re-)approached. First, his view of the individual as residing with multiple “social atoms” underscores the importance of notion of *duality*; that is, the individual as the point of intersection of multiple group memberships. Secondly, with his pervasive interest in psychological development and psychotherapy, and aided by a methodology that retained its focus on one’s immediate social network, Moreno was thoroughly concerned with the issue of temporal aspects of networks, as well as their change over time. He thus addressed the dynamic character of networks. Both of these concerns have been major theoretical issues within contemporary network analysis (Marsden, 1990). Finally, Moreno’s concern with individuals’ motivations as shaping and shaped by their social network is an engagement with human cognition that modern network analysts have largely traditionally avoided. Indeed the role of cognition is a contentious one within social network analysis, and serves as a theme for this chapter.

### **2.2.2. Manchester/LSE school**

The school of network analysis which has had the most influence upon the study of language in particular grew out of the work of a group of social anthropologists at Manchester University and the London School of Economics beginning in the 1950s, including the works of Max Gluckman,



Elizabeth Bott, John Barnes, J. Clyde Mitchell, and others (Freeman, 2004). These researchers were heavily influenced by the structuralist views of the prominent social anthropologist Alfred Reginald Radcliffe-Brown. Like other structural thinkers, Radcliffe-Brown saw explanation of social phenomena in relational terms. However, he was the first to foresee the application of mathematical methods to analyze social structure (Freeman, 2004), which he saw on a much larger scale than did Moreno's highly localized sociometric methods:

The kind of mathematics which will be required ultimately for a full development of the science of society will not be metrical, but will be that hitherto comparatively neglected branch of mathematics, the calculus of relations, which, I think, is on the whole, more fundamental than quantitative mathematics. (Radcliffe-Brown, 1952, p. 69)<sup>6</sup>

Radcliffe-Brown, however, left the work of formulating such methods to others, most notably the Manchester/LSE school of network analysis.

Below, I provide a brief overview of the most basic network concepts, including various ways of describing the interactional aspects of the relations within the network, as well as ways of describing the overall morphology of network. While the concepts outlined below are not themselves the subject of analyses in the network study found in Chapter 5, a basic familiarity with the methods and terms of the Manchester/LSE school is needed as important background information for discussing human behavior in terms of social exchange, as is done prominently within the analysis chapters (4 and 5).

---

<sup>6</sup> Quantitative mathematics requires that the variables under examination be based on units of measurement that are both relational and additive (Barrett, 2003). Network structure, which entails not only the number of nodes in a network, but also the presence and absence of ties between all nodes, is inherently non-quantitative. However, "Quantity is not synonymous with mathematics" (Barrett, 2003, p. 430), and as such, non-quantitative, relational calculus can and does serve as the mathematical basis for social network analysis. Additionally, the nature of many psychological variables as additive, and thus quantitative, has been challenged (Barrett, 2003). Awareness and sensitivity among network analysts to this issue may be one reason why many steer clear of psychological constructs in their analyses.

## ***Concepts and methods***

Mitchell (1969) outlines a few basic notions of interpersonal interaction upon which a network approach relies. The most basic terms are perhaps *frequency* and *intensity* of interaction, referring to the rate of interaction and the strength of one's obligation to the other (see also Kapferer, 1969). Additionally, he sees the *content* of a tie as the most important interactional component, denoting the "meanings which the persons in the network attribute to their relationships" (Mitchell, 1969, p. 20). His examples include economic assistance, friendship, familial obligation, and so forth. Kapferer (1969), by contrast, divides exchange content into categories such as conversation, joking behavior, job assistance, personal service, and cash assistance. In either case, however, content generally can be seen as the social meanings and activities which constitute the interdependence which brings (a portion of) a network together. In considering what it is that individual exchange, network approaches can describe the interdependencies among actors.

Exchange content underlies another important notion within network analysis: *multiplexity*. Multiplex relationships are those relationships with several exchange contents, such as working together and sharing leisure time (Kapferer, 1969; Mitchell, 1969). In either case, multiplex relationships tend to be stronger/more intense than uniplex ones (relationships consisting of a single exchange content).

Drawing on earlier work by Bossard, Kephart (1950) first introduces *density* (although he does not use this term) as a systematic, quantitative basis for the study of group dynamics. The most popular group-level measurement (Wasserman & Faust, 1994), density is the proportion of actual ties within a network to the number of possible ties, and thus can range from 0 within networks without any relationships at all to 1 within completely interconnected networks. The notion quickly gained prominence within the social anthropologists of the Manchester/LSE school,

who used density as an index to indicate “knittedness” (interconnectedness) of a network.<sup>7</sup> Close-knittedness is often found to be associated with greater differentiation tasks and activities among community members (e.g. Bott, 1957).

Finally, another significant interactional concept is the *directional flow* of the relationship (Kapferer, 1969; Mitchell, 1969). As seen in the following section (2.3.1), this general notion of flow has served as one of the predominant metaphors within network analysis, in which various material and symbolic resources flow from individual to individual (Borgatti, *et al.*, 2009).

More generally, researchers have delineated different regions, or zones, of personal networks. For instance, Wheeldon (1969) differentiates between the *effective* versus *extended* elements of a network; one’s effective network is that portion of the network with whom one has active ties involving relatively frequent and intense interaction. One’s extended network, by contrast, includes individuals one encounters on an infrequent basis. Mitchell (1969) differentiates between one’s *first-order* and *second-order* network. The former consists of one’s direct ties, while the latter includes those individuals one step removed (e.g., friends of friends).

### **2.3. Current state of network analysis**

The past 35 years have seen a considerable conceptual and methodological expansion of network analysis (owing in part to technological advances). Much of this can be attributable to the work of Harrison White, who along with his students at Harvard University – including Mark Granovetter, Barry Wellman, and Bonnie Erickson, among others – has helped form the current foundation of modern network analysis. Through their contributions (and those of many others), network analysis has gone from a social anthropological approach whose mathematical methods remained fairly simple, to a mathematically nuanced approach marked by a great breadth and depth

---

<sup>7</sup> The terms ‘close-knit’ to describe networks that are highly interconnected (dense), and ‘loose-knit’ to describe networks that are sparser (less dense) have been attributed to Elizabeth Bott (1957), although the use of the term is pervasive among her contemporaries as well. Among her conclusions, Bott maintains that closer-knit family networks tend to demonstrate greater differentiation of daily tasks.

of complex computational approaches for representing a variety of structural characteristics in graph-theoretic form.

In this section, I review the cornerstones of the current state of social network analysis. First, I provide an overview of the concepts of *centrality* and *cohesion*, in which researchers seek to explain the causal mechanisms of social networks in terms of the *flow* of resources across ties (Borgatti, *et al.*, 2009). Second, I look at *role equivalence*, in which network analysts explain behavior in terms of one's *architecture* or pattern of the social ties. These respective approaches – termed the *relational* approach (flow) and the *positional* approach (architecture), respectively – constitute the foundation of much of social network analysis. Furthermore, they form the basis for the hypotheses and resulting analyses found in the network study in Chapter 5.

### **2.3.1. Relational approach: Flow over ties**

The metaphor of 'flow' that underpins the relational approach alludes to the theorized transmission of tangible and symbolic resources (e.g., information, assistance, emotional support, material goods, infection, etc.) across social ties. This metaphor is intended to evoke a notion similar to the way in which traffic circulates around a transportation network, or water flows through a system of pipes. By analyzing the direct and indirect ties that link actors to each other, one can measure the probability that the focal actor will gain possession of a flowing resource, relative to other actors. The notion of flow is crucial because it highlights the dynamic processes that occur along network ties (and helped to form the network structure itself), facilitating greater understanding about the actor's role in these processes (Borgatti, 2005).

As mentioned, the flow metaphor underlies two interrelated concepts within a relational approach to network analysis: *centrality* and *cohesion*. The two concepts are highly similar in that they draw on the same fundamental concept of "the social proximity of pairs of actors" (Borgatti & Everett, 2006, p. 17). The difference lies in analytical focus. With centrality, the emphasis lies on the

individual actor's role in transmitting resources. By contrast, analysis of cohesive subgroups seeks to delineate larger social entities in the form of groups or 'clusters' of individuals who share resources disproportionately more with each other than with individuals outside the cluster.

### ***Centrality***

The identification of the most important actors within a network has long been one of the central aims of social network analysis (Wasserman & Faust, 1994). Such an objective dates back to sociometry and Moreno's (1953) methods of determining "stars" and "isolates" within a network. More recently, network analysts have used the broad concept of *centrality*. Centrality is a family of node-level measures describing the node's (actor's) level of involvement in social processes that occur across interpersonal relationships (Borgatti, 2005; Borgatti & Everett, 2006). These social processes – generally constituting the researcher's analytical focus – can range from various notions of communication and information sharing to the spread of contagious diseases. Involvement denotes *opportunity* – either to participate in the process, to benefit from it,<sup>8</sup> or to affect its course.

Numerous centrality measures exist (alongside many possible theoretical forms; see Borgatti, 2005). For instance, Freeman (1979) builds upon earlier work by small group researchers such as Bavelas (1950), Leavitt (1951), and Shaw (1954), who were interested in group positions in which one individual can exercise power over others through controlling the flow of information to others, as well as avoiding the control of others. Freeman (1979) formulates two of the most prominent measures of centrality: *betweenness* and *closeness*. Both of these views of centrality highlight the power that "go-betweens" or intermediaries have.<sup>9</sup> In terms of betweenness, "[p]ositions are viewed as structurally central to the degree that they stand between others and can therefore facilitate, impede or bias the transmission of messages" (Freeman, 1979, p. 36). In other

---

<sup>8</sup> 'Opportunity' should not always denote 'benefit.' For example, in a needle-sharing network of drug users, centrality-as-opportunity represents risk of infection.

<sup>9</sup> Granovetter's (1973) assertion that weak ties serve a crucial role in the diffusion of information thus shares much with a notion of betweenness. Possession of weak ties increases an individual's betweenness.

words, betweenness is a measure of the degree to which an individual connects those who are otherwise unconnected, and can therefore control flow between these individuals. Conversely, closeness highlights the focal node's relative freedom from such intermediaries in accessing the entire network. Individuals high in closeness benefit from a greater 'directness' of transmission; they are less reliant on others to access the entire network.

These two measures are crucial in that they illustrate what Borgatti and Everett (2006) argue is the single most fundamental distinction between centrality measures: *radiality* versus *mediality*. Radial measures (e.g., closeness) summarize the focal node's proximity to other nodes, thereby indexing notions of group membership. By contrast, medial measures summarize the focal node's positioning along paths that connect other nodes; such measures index opportunities for *brokerage*, or control over the passage of information. Notions of group membership (radial measures) and bridging between groups (medial measures) feature significantly in Chapter 5.

### ***Cohesion***

Another way to approach the transmission of resources across direct network linkages is by looking at how resources flow disproportionately within clusters of proximate individuals. For instance, cohesive clusters constrain information flow, allowing redundant information to circulate repeatedly within the subgroup, while shielding its members from new, nonredundant information coming from outside the subgroup. The basic structural property of subgroups is their internal density: ties between members of the same subgroup are disproportionately high in comparison to ties to individuals outside the groups.

This disproportion of internal to external ties serves as the basic rationale for various methods of delineating cohesive subgroups. The earliest (and most popularly recognizable) formal definition of a cohesive subgroup is the *clique*. In its most restrictive sense, a clique is a collection of actors within which a cohesive bond exists between every two actors; every actor can reach every

other actor directly. Drawing on Luce and Perry's (1949) definition of a clique, Alba (1973) emphasizes the notion of completeness within such a strict definition: "Every pair of points [e.g., individuals] in a clique is adjacent, and the addition of any point to the clique makes it incomplete. For example, if the relationship under consideration is friendship, a clique is a group of individuals, every two of whom are friends, which excludes no one who is a friend of everyone in the clique" (p. 116). However, Wasserman and Faust (1994) note that the completeness requirement is often too restrictive, thus limiting its practical usefulness. Cliques found in empirical networks tend to be small and overlap with other small cliques. Additionally, in complete cliques, all members are equally embedded. They therefore lack internal structure, further impeding their practical usefulness. Consequently, the clique serves as a starting point for practical definitions of larger clique-like structures. Various conceptualizations of such structures can be formulated by loosening various required properties of the clique (Wasserman & Faust, 1994). Such clusters are characterized in the general terms in terms of the number of ties connecting actors within a network, the strength of those ties, and the length of the paths (the number of intermediaries that exist between two actors).

However, with each definitional relaxation come various complications in the form of unwanted properties, provoking a number of conceptualizations for the cohesive subgroup. For example, the *n-clique* (Luce & Perry, 1949; Alba, 1973) relaxes the requirement that all group members be connected to all others. This is accomplished by restricting the diameter – or the number for number of "steps" of relationships that can exist between members – to *n*. In other words, within a 2-clique, for instance, no member is separated from any other member by more than two steps (i.e., a maximum of one intermediary may exist between members). However, this definition is problematic in that the intermediary need not be a member of the same *n-clique*. To rectify this issue, additional conceptualizations have been advanced, including *n-clan*, *n-club*, and *k-plex* (see Wasserman & Faust, 1994, for explanation). Selection of a given cohesive subgroup for

analysis thus requires consideration of the underlying assumptions regarding the social process under investigation (see Borgatti, 2005).

### **2.3.2. Positional approach: Architecture**

A positional approach focuses on “the similarity of actors’ profiles of network relations” (Marsden & Friedkin, 1994, p. 7). The architecture metaphor of this approach pertains to the similarity in the pattern of ties, analogous to the blueprints for similar buildings. The notion of architecture is crucial because it captures the essential notion of available alternatives that underpins the decision-shaping function of networks. Certain individuals have more or different alternatives than do others by virtue of their relational configuration.

Relational patterns are seen as the structural foundation of social roles. In explaining the relational underpinnings of what he calls *role-sets*, Merton (1957) cites the example of the medical student, who occupies interdependent roles with his/her teachers, other medical students, patients, and an array of other personnel. Individuals with similar role-sets are seen as adopting similar attitudes and behavior through equivalent social pressures and through modeling of each other’s behaviors. Burt (1987) argues that in a society marked by an avalanche of information regarding potential behavior (e.g., via mass media, through commercial interests in spreading innovation, etc.), it becomes necessary for the individual to find ways of obtaining *trustworthy* information and ignoring the rest. Ego must look to alters to determine the relative costs and benefits of a given behavior.

#### ***Role equivalence***

The analytical task of finding equivalent sets of social roles is accomplished by various concepts of role equivalence. The three general forms of role equivalence, ranging from most concrete to most abstract, are *structural equivalence*, *automorphic equivalence* (or *structural isomorphism*), and *regular equivalence*. Lorrain and White (1971) and Burt (1976) both offer initial



definitions for the most specific form of role equivalence, *structural equivalence*. Two actors are structurally equivalent when they are “connected in the same way to the rest of the network” (Borgatti & Everett, 1992a, p. 3). Structurally equivalent individuals do not necessarily (but can) have a direct link (strong or weak) between each other (though this is irrelevant to the definition). An illustrative example of this type of structural equivalence would be siblings (ideally twins), who hold the exact same set of relationships with the exact same individuals (parents, other relatives, other community members).

The social psychological explanation of behavior that accompanies the mathematical notion of structural equivalence rests on a relatively simple notion of social comparison and competition. First, structurally equivalent individuals are theorized to regard one another as normative models (Burt, 1987). In an information-rich world, individuals look to structurally equivalent alters to get a better idea of the relative costs and benefits of adopting a given behavior. Because of their (nearly) identical set of relationships, structurally equivalent individuals are socialized in a similar way by those around them, owing to the identical content of their respective relationship sets. From ego’s perspective, observing the behavior of a structurally equivalent alter is more likely to provide an accurate cost-benefit analysis of said behavior because the similarity in their relationships translates into a similar set of opportunities, obligations, and other normative influences.

Second, given (nearly) identical sets of relations within the network, structurally equivalent individuals are theorized as likely social competitors (Burt, 1987). In order to avoid losing their attractiveness as an exchange partner, they must compete with one another for exchange with the same individual(s). They must either imitate each other’s innovations, or sufficiently differentiate themselves from one another in terms of their behavior.

In order to make structural equivalence a more usable concept in empirical settings, various efforts have been made to ease the strictness of the graph-theoretical definition, permitting

different methods to assess degrees of structural equivalence, as well as blockmodeling methods which differentiate network members into “blocks” of approximately structurally equivalent actors (White, *et al.*, 1976). Second, structurally equivalent actors are often located within cohesive subgroups, giving rise to difficulties in differentiating the social influence owing to cohesion from that associated with structural equivalence (Marsden & Friedkin, 1994). Consequently, Borgatti and Everett (1992a) characterize structural equivalence as “conceptually inelegant” and recommend its use only when structural equivalence is specifically theoretically justified over other definitions of role equivalence.

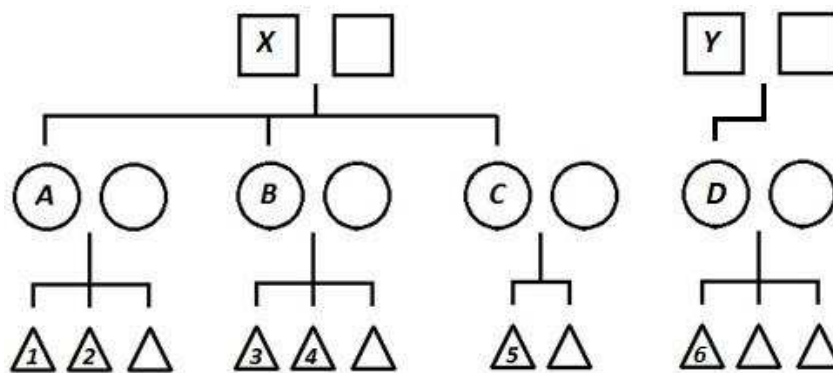

**Figure 2.2.** Family trees as an example of structural, automorphic, and regular equivalences.

Structurally equivalent actor sets: {1, 2}, {3, 4}

Automorphically equivalent actor sets: {1, 2, 3, 4}, {A, B}

Regularly equivalent actor sets: {1, 2, 3, 4, 5, 6}, {A, B, C, D}, {X, Y}

As a result, more abstract notions of role equivalence that are not confounded with cohesion have been introduced. In particular, *automorphic equivalence* (Winship & Mandel, 1983) and *regular equivalence* (Borgatti & Everett, 1989) are formalizations of early conceptualizations of social role, defined in terms of the bundle of role-relationships in which an actor participates (Merton, 1957; Borgatti, *et al.*, 2009). Automorphic equivalence focuses on the degree to which individual nodes occupy analogous regions within the same network.

*Regular equivalence* eases the definition even further, characterizing an actor by the overall set of actor-types among his/her first-order network. Regular equivalence thus describes the degree to which individuals merely have the same set or relation-types, regardless of the quantity of each relation-type or their presence in the same connected network (see Figure 2.2 for an illustration of these terms). In all, structural, automorphic, and regular equivalence are increasingly abstract ways of representing the position, with automorphic equivalence entailing regular equivalence, and structural equivalence entailing the other two (Figure 2.3).<sup>10</sup>

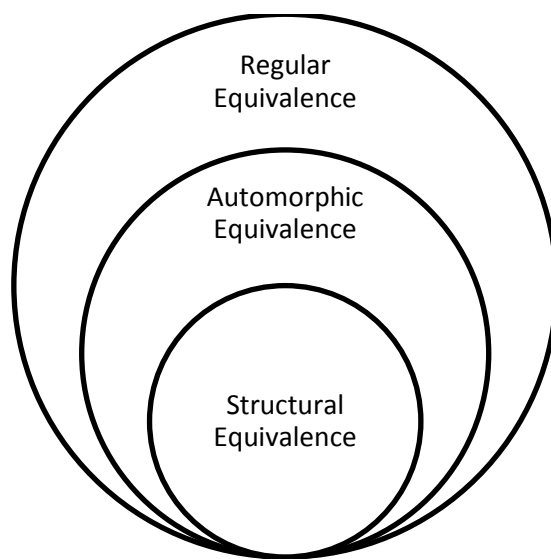

**Figure 2.3.** Venn diagram of role equivalences.

### **2.3.3. The thin psychology of social network analysis**

As seen in the previous section, social network analysis provides an array of structural concepts to which various social psychological explanations for behavior are attached. It would be convenient if formulating a network approach to L2 learning and use could start by simply incorporating a basic array of traditional social psychological theories found within frameworks of L2 motivation and use. Such a theoretical suite would include, most prominently, the social identity/social categorization approach as formulated by Tajfel (1978) and others. Holistic in its

---

<sup>10</sup> In Chapter 5, role equivalence is used, assessed by means of the REGE and CATREGE algorithms (Borgatti & Everett, 1992b).

theoretical stance, the social identity/social categorization approach affirms the basic reality of the social group. The individual is viewed as fundamentally a part of his or her social context, with his or her various group memberships being integral aspects of the self.

Given the obvious salience of ethnic group identities in intergroup situations, the intergroup approach has featured prominently in various theories of L2 motivation and situated L2 use (e.g., Giles, *et al.*, 1977; Clément, 1980; Giles & Byrne, 1982; MacIntyre, *et al.*, 1998; Clément, *et al.*, 2003), including the framework for *willingness to communicate in the L2* (MacIntyre, *et al.*, 1998) itself. Indeed, at a very basic level, a network approach and social identity/ social categorization approach share the same fundamental goal of adequately describing the relationship between the individual and the social environment. Both approaches hold the common core assumption that the interdependence of individuals to be a fundamental feature of collective life (Lewin, 1948).

Despite their common theoretical assumptions, however, links between these approaches have gone largely unarticulated. This owes largely to differing emphases on causes of social behavior (House, 1977; Stryker, 1977):

For psychological social psychology, the field is defined by its focus on psychological processes of individuals; the task is to understand the impact of social stimuli on individuals.

For sociological social psychology, the field is defined by the reciprocity of society and individual; and the fundamental task is the explanation of social interaction (Stryker, 1977, p. 145).

Psychological social psychologists have thus devoted their efforts to investigations of social behavior as it originates out of the inner experience of the individual. This approach therefore draws on various cognitive, affective, and motivational theories that describe the link between the personal and the social. By contrast, sociological social psychologists, including network analysts, have traditionally sought to explain social behavior – including roles, groups, social norms and

interpersonal behavior – in terms of the situational constraints (e.g., social reinforcement, punishment) that impinge upon behavior. Network analysts in particular have sought explanations first and foremost in terms of structure, relying on as few explicitly psychological principles as possible.

As a result of this focus on system, the psychology of social networks has traditionally been a pervasively “thin” one, only going so deep as to explain basic psychological processes and human drives that bring individuals together into network structures. Once one explains a basic social motivation, network explanations of action can be built upon a relative handful of behaviorist and rational choice principles of social exchange (Thibaut & Kelley, 1959; Homans, 1961; Blau, 1964). These theories generally hold that informal, seemingly noneconomic social interactions can be described in economic or behaviorist terms, such as resources, cost and reward, utility, outcome, transaction, payoff, and so on (Emerson, 1976).<sup>11</sup> In particular, exchange theory is concerned with how social structure constrains the rewards and costs associated with social interaction. It explains exchange relationships as an emergent phenomenon; the configuration of ties surrounding two individuals impinges on the exchange between them, determining the availability of alternatives and thus power and dependence between them.

For instance, Blau (1964) discards psychological processes as explanations for social phenomena, maintaining that while psychological processes do exist and are valid in their own right, they are not explanatory of social phenomena (e.g., norms, roles). Rather, social phenomena are emergent characteristics of the relationship between actors, not of the actors themselves. In highlighting the pitfalls of incorporating psychology into studies of social interaction and structure, he also succinctly characterizes structuralism’s tenuous relationship with psychology:

---

<sup>11</sup> Cook and Whitmeyer (1992) agree with Mitchell (1974) in claiming that social network analysis and social exchange theory are fundamentally compatible and allied theories which both examine the structural bases of individual action, and thus share many of the same assumptions, not the least of which is their common view of the self-interested yet interdependent actor. As such, social exchange theory is offered here as the most well-developed theory of action among network theories.

To be sure, each individual's behavior is reinforced by the reward it brings, but the psychological process of reinforcement does not suffice to explain the exchange relation that develops. The social relation is the joint product of the actions of both individuals, with the actions of each being dependent on those of the other. The emergent properties of social exchange consequent to this interdependence cannot be accounted for by the psychological processes that motivate the behavior of the partners. (p. 4)

For these reasons, Blau views interpersonal attraction as the only causal factor of social phenomena that originates within the individual. He takes decision theory as a starting point, replacing psychological concepts (e.g., reinforcement) with those of economic rationality (e.g., reward). In doing so, he can ascribe rationality to both humans and emergent social structures. For example, corporations can be social actors, because they make decisions rationally.

Thibaut and Kelley (1959) explicitly note that while motivation is not inherently incompatible with structuralist psychology, the inclusion of unobservable factors to explain social phenomena can lead to dubious theorization:

At times we have been tempted to invoke certain special social motives (e.g., a need for power or status) to explain social phenomena. That we resisted this temptation is not to deny the existence of such motives nor to deny the importance for social psychology of a careful analysis of them... However, since the list of such motives is still an open-ended matter and an indefinite number of plausible ones may be added, the appeal to a motive to explain any given social phenomenon seems both too "easy" and too unparsimonious... [O]ne may too easily refer to plausible learned drives or acquired reinforcements as the need arises. (p. 4)

Positing motivation as a cause of social phenomena is therefore a potential pitfall, as one may too easily conjure up theorized psychological drives in lieu of pursuing structural explanations for behavior.

Robins and Kashima (2008) sound a more practical note in explaining the general adoption of support of behaviorist/rational accounts within network explanations of social behavior. They note that such accounts allow network analysts pursue sociological explanations without getting bogged down in simultaneous psychological theorization:

The complexity of the system... can be beguiling and gives researchers plenty to confront without dealing with the complications of individual-level effects. Topology without people can be difficult enough (p. 2).

However, in this case, the sociologist's parsimoniousness is the psychologist's oversimplification. In the following section, I briefly outline some attempts at producing an adequately sophisticated account of the agent operating within structure.

#### **2.3.4. "Social networks matter. But how?"**

While structural researchers laud behaviorist/rationalist accounts of social behavior as parsimonious, others have roundly criticized it as overly simplistic and deterministic (Emirbayer & Goodwin, 1994; Mizruchi, 1994). Robins and Kashima (2008) criticize social network analysis' seriously under-theorized account of the cognitive and affective nature of the individual. Network analysts have tended to treat the individual as little more than a node within a structural topology, or a repository for rather simplistic set of attitudes and behaviors which are generally treated only as dependent variables.

The primary hazard of these simplistic behaviorist/rationalist accounts is their inability to explain how networks coalesce or change in configuration through the actions of the actors themselves (Emirbayer & Goodwin, 1994). As White et al. (1976) note, "models of structure are not

sufficient unto themselves. Eventually one must be able to show how concrete social processes and individual manipulations shape and are shaped by structure.” (p. 773). This, of course, is a balancing act, as asserted by Granovetter (1985), who notes:

A fruitful analysis of human action requires us to avoid the atomization implicit in the theoretical extremes of under- and oversocialized conceptions. Actors do not behave or decide as atoms outside a social context, nor do they adhere slavishly to a script written for them by the particular intersection of social categories that they happen to occupy. Their attempts at purposive action are instead embedded in concrete, ongoing systems of social relations. (p. 487)

Granovetter therefore argues that human action must be understood with respect to the structure of routine social interactions that individuals know and trust. Accordingly, network accounts of human action require an explanation of how members may effect change on their surroundings, while still being shaped by that context.

A simple question requiring a complex answer is thus posed: *How do networks impact behavior?* Various initial attempts at addressing this issue have recently been made. A crucial commonality of these is their attention to the notion of *opportunity* for action. For instance, Burt (1992) asserts the role of agency in seeking out the opportunities provided within one’s immediate social network. Situating his theory of *structural holes* predominately within an organizational context, he maintains that particularly effective individuals exercise agency by consciously seeking out and occupying advantageous, open network locations adjacent to sparsely-connected areas at which one may serve as a unique information bridge between otherwise disconnected individuals. In explaining how these opportunities (‘structural holes’) are subsequently exploited, he raises the issue of motivation:



[O]pportunities do not by themselves turn into achievement, and some people are not comfortable pursuing the information and control benefits of structural holes. Thus the motivation issue: To what extent is the connection between success and brokerage contingent on having a personality suited to working with structural holes? The motivation issue can be assumed away, dismissed as correlate of social structure, or addressed directly” (Burt, *et al.*, 1998, p. 65)

More specifically, one taking a network approach can “assume away” motivation as merely being presented with the larger number of opportunities that are inherent in a sparser network, as done prominently by previous network theorists adopting behaviorist/rationalist accounts of action. Burt, however, opts for the latter option, seeing the agent as a motivated entity who actively seeks out and manipulates opportunities for action. An example of this is his proposed “network entrepreneur” personality type, characterizing “an independent outsider, in search of authority, thriving on advocacy and change” (Burt *et al.*, 1998, p. 78).

A similar, yet more elaborate account of the functions of social networks is offered by Passy (2002). In her article entitled “Social networks matter. But how?” Passy (2002) addresses the crucial question of how social networks impact the actual behavioral choice to participate in collective action and social movements – an area in which retaining a concept of agency is essential. She notes that “[s]ocial networks matter, but they do so by performing various functions in the process of individual participation” (p. 41). She argues for three primary functions of social networks in influencing action/behavior, which range from distal influences on initial disposition, to providing opportunity for action, to placing immediate constraints on choice of action: the *socialization function*, the *structural-connection function*, and the *decision-shaping function*, respectively.

Perhaps the most apparent way in which social networks affect behavior is through helping to create and shape identities (Passy, 2002). When interaction between two or more individuals

becomes frequent and regular, it becomes mutually recognizable, and thus predictable and cognitively economical (Berger & Luckmann, 1966). These relationships become part of an intersubjective social reality, providing enduring frames of reference which help create, shape, and re-shape an individual's various social identities, values, and beliefs. Brass and Burkhardt (1993) explain the link between structure and regularized interaction:

[W]e view structure as representing relatively stable patterns of behavior, interaction, and interpretation. These institutionalized patterns emerge as recurrent interaction over time takes on the status of predictable, socially shared regularities... (p. 443).

The long-lasting influence that network environments exert represents the *socialization function* of networks. One's web of (past and present) social interactions conveys messages and meanings that continually shapes the way in which one comes to interpret social reality, thereby constructing the culturally-ingrained "push" factors which drive an individual to behave in a given way, such as initial dispositions, socially ingrained values, tastes, beliefs, and norms.

The ongoing influence that social networks exert on human behavior is further encapsulated within the other two functions of networks, as described by Passy (2002). First, in the absence of opportunities, predispositions will remain unrealized (Ajzen, 2005). The *structural-connection* function of networks serves to link individuals to "pull" factors – the immediate opportunities for participation available through social relationships, which allow actors to convert their intentions into action. Social ties may connect an individual to social groups, to material resources, or to valuable information and innovation that allows them to behave in new or more effective ways.

Lastly, the decision-shaping function is the coordinated (inter)action taken by individuals within a network. "[E]go' as a rational actor must take into account what 'alter' does (or will do) ... The basic idea is that cooperative social behaviour is an outcome of rational self-interested actors, because they must consider others' intentions and actions." (Passy, 2002, pp. 7-8). This function

takes on added importance when looking at interpersonal communication, as it is a fundamentally interdependent activity, requiring at least two individuals.

Whatever the particular nature of the behavior, however, taking action involves potential rewards and costs which vary according to a range of situational factors. In cases of social participation, including intercultural communication, matters are further complicated by a great deal of uncertainty as to how to assess rewards and costs (from the perspective of both the individual and the researcher). Indeed, several scholars (e.g., Emirbayer & Goodwin, 1994; Passy, 2002) criticize the prevailing instrumentalist-rationalist conceptualization of networks, which still adopt rational (or behaviorist) frameworks (see below). However, both sets of arguments retain an underlying emphasis on the impact that having alternatives to a given course of action has on one's behavior. McAdam and Paulsen (1993), for example, conceptualize costs and rewards in terms of whether a given decision "resonates" with one's identities, and to what degree the decision conflicts with countervailing identities. Whether one conceptualizes 'cost' and 'reward' in strict utilitarian terms, or in terms of fulfilling/contradicting one's various social identities, the final decision point comes with a weighing of the alternatives made available to the individual through his/her personal relationships.

The importance of the notion of *opportunity* for action thus becomes evident. Explanations of system provide explanations of where possibilities for action reside. Still needed, however, is a rich account of how opportunities are perceived, interpreted, acted upon, and (re)created. As seen in the following section, modern applications of network analysis have dealt explicitly with this issue in the form of social capital, though much work remains to be done in detailing a sufficient psychology of networks.

### 2.3.5. Modern applications of network analysis to the social sciences

Despite the theoretical friction between traditional social psychology and network analysis, parsimonious explanations of system are a tantalizing promise for social scientists in general. Therefore, network analysis has been extensively employed within the social sciences. Its general application has displayed several general trends. First, network studies in the social sciences have more often treated network variation as cause, rather than consequence.<sup>12</sup> Second, of considerable interest has been investigating universals of human social networks. Third, in keeping with an individualistic focus of social science theories more generally, network studies have tended to focus on outcomes at the level of the individual, rather than at the level of the whole-network (Borgatti, *et al.*, 2009).

To follow is a limited summary of modern applications of network analysis in describing system, as well as the actor's relation with system. In the interests of focus and space, however, I limit the review only to those concepts which bear relevance to the studies found in this thesis, particularly the network study found in Chapter 5. First I provide a brief overview of relevant issues within network description, namely, clustering and homophily. Second, I outline prominent applications of network analysis to individual-level outcomes of network position. In particular, these outcomes generally take one of two forms: *social homogeneity* (in attitudes, values, behavior, etc.) or *variation in performance* (professional, academic performance, etc.) (Borgatti & Foster, 2003).

#### ***Description of networks: Clustering and homophily***

One general strand of network studies focuses purely on the description of network topography. One typical, if quite general, characteristic of human social networks that is relevant to the current thesis is the distinctive tendency of human social networks to form clusters. Large

---

<sup>12</sup> However, the notion of structure and behavior as reciprocally determined is crucial within theories of social exchange (e.g., Brass & Burkhardt, 1993; Cropanzano & Mitchell, 2005) and more generally.

collections of individuals tend to coalesce into many relatively small, dense clusters of individuals who are sparsely linked together by weak ties. This pattern arises out of two “weak assumptions” of network theory (Wellman, 1988, p. 42). The first is the basic physical reality that time and space limit the number of relationships that an individual can establish and maintain, loosely capping the number of ties that an individual will have. The second is that relationships tend to be *transitive*: for example, the likeliest source of new friendships is one’s pool of friends of friends. The result is a clumpy, scale-free distribution of networks in which individuals cluster together. In turn, these clusters are sparsely interconnected (Newman & Park, 2003). This effect is perpetuated by a tendency of new nodes (i.e., new network members) to form ties with individuals with many ties by sheer virtue of their popularity (Barabási & Albert, 1999).<sup>13</sup> This broad tendency of human social networks is crucial to subsequent conceptualizations of bridging social capital (see below), as the medial positions which link clusters can control the flow of information between clusters.

Combined with this clustering tendency is the prevalence of like associating with like, or *homophily*.<sup>14</sup> Homophily is “the principle that a contact between similar people occurs at a higher rate than among dissimilar people,” (McPherson, et al., 2001, p. 416); those with similar sociodemographic (especially race and ethnicity), behavioral-attitudinal, and interpersonal characteristics more frequently have relationships with one another than with dissimilar individuals. The impact of homophily is to limit the spread of resources. As McPherson et al. (2001) note, “The pervasive fact of homophily means that cultural, behavioral, genetic, or material information that flows through networks will tend to be localized” (p. 416). In other words, the existence of homophily inhibits the widespread dissemination of certain types of information across a network. This is thought to be because individuals selectively transmit information that dissimilar individuals are more likely to find unimportant, or uninteresting, or otherwise irrelevant.

---

<sup>13</sup> Barabási and Albert (1999) link this effect of “the rich getting richer” to Merton’s original evocation of the ‘Matthew’ effect.

<sup>14</sup> Or, as summarized in the popular adage, “birds of a feather flock together.”

### ***Network as antecedent: Social homogeneity versus social capital***

As mentioned, a majority of network studies in the social sciences have focused on network features as an antecedent to individual-level behavior and outcomes (Borgatti, *et al.*, 2009). Indeed, the network study found in Chapter 5 follows this pattern. However, out of this group of researchers, two general strands may be noted: studies of social homogeneity in attitudes, beliefs, and practices; and social capital studies of differences in performance and success (Borgatti & Foster, 2003). While researchers working in either strand share a fundamental *analytical* goal of detecting relationships between network structure and individual-level phenomena (attitudes, behavior, etc.), there is an important split between the two in terms of the differing *theoretical* implications that researchers assign to their analogous pattern of results.

Network researchers focusing on social homogeneity are primarily concerned with “the social structural circumstances of ego and alter [that] makes them proximate such that ego’s evaluation of the innovation is sensitive to alter’s adoption” (Burt, 1987, p. 1288). The central analytical task becomes identifying and measuring various conceptualizations of “social proximity” between actors which serve as conduits of social influence and diffusion of innovation/information. Employing notions of cohesion, centrality, and role equivalence, as discussed above, these researchers seek to determine how proximity between actors affects their similarity on a given behavior, opinion, attitude, or other adopted characteristic. For instance, studies of diffusion and influence within cohesive subgroups seek to explain direct socialization effects of normative environments which are either maintained by network density and closure, or erode away under conditions of network sparseness and diversity (Friedkin, 2004). Friedkin and Johnsen (1999) demonstrate the lack of hierarchy within dense subgroups permits in widespread interpersonal influence among all members, resulting in a great deal of conformity among members, as every individual has influence on every other individual.

Ultimately, however, this view of human behavior is non-evaluative; little attention is paid to whether attitudes, belief, and practice are adopted for good or for ill (Borgatti & Foster, 2003). This pure focus on adoption of innovation leaves little room to explain how such innovation may aid, hamper, or be otherwise used by the individual in his or her daily life. The result is deterministic take on human behavior; focus resides on how individuals merely take up these innovations wholesale, rather than how they themselves subsequently employ these innovations creatively for their own purposes.

By contrast, theories of *social capital* (Burt, 1992; Portes, 1998; Lin, 2001; Adler & Kwon, 2002) emphasize the *opportunities* for potential action that ties provide to the individual, recognizing that the outcome may not be pre-determined. As Borgatti and Foster (2003) note, “social capital is ‘just’ a powerful renaming and collecting together of a large swath of network research,” (p. 993) which generally describes the various latent social advantages that may exist within one’s social relationships. Accordingly, social capital literature includes a range of outcome studies in areas such as social support (Walker, *et al.*, 1994) and management (e.g., Brass & Burkhardt, 1993).

Two highly significant conceptualizations of social capital which hold particular relevance to the current thesis are Coleman’s (1988) view of network closure and Burt’s (1992) theory of structural holes. These theories make competing claims as to the value of the constraint one faces by virtue of social ties.<sup>15</sup> Coleman (1988) asserts that being embedded within a highly cohesive network is conducive to the development of social norms that promote cooperation and beneficial interdependence. Through a closed network, individuals can effectively maintain adaptive social

---

<sup>15</sup> One commonality in Coleman (1988) and Burt’s (1992) respective explanations of social capital is their “structuralist” perspective (Borgatti & Foster, 2003); both scholars emphasize social capital as the topographical configuration of social ties, rather than the actual resources that these ties contain. By contrast, connectionist accounts of social capital place an emphasis on the actual resources one has access to through one’s social ties (van der Poel, 1993; Lin, 2001; van der Gaag & Snijders, 2005; van der Gaag, *et al.*, 2008), such as information, shared material resources, instrumental aid, and socio-emotional support.

norms, perpetuating a system of expectations, obligations, and trust that allows network members to interact more effectively.

By contrast, Burt's (1992) maintains that too many cohesive ties block individuals' access to new, beneficial information, thus putting one at a competitive disadvantage with others. Rather, having an open, diverse network – in which one is the unique link between otherwise disconnected groups – is an asset. This concept has long served as a foundation of the most influential network theories. Granovetter's (1973) theory of weak ties describes the informational advantages associated with weak ties, which provide unique, nonredundant information.<sup>16</sup> This notion of 'bridging' social capital appears again in Chapter 5.

In all, therefore, social homogeneity studies and social capital studies differ markedly in the role that interindividual variation is assumed to play in a larger view of human behavior. While homogeneity studies favor a deterministic take on structure and behavior, social capital studies endorse a more agentic conceptualization of the actor, permitting the view that individuals shape their own structural opportunities in addition to being shaped by them. Indeed, the agentic take offered by theories of social capital is crucial to the aims of this thesis. Required is a systematic account of the opportunity to use the L2 that still does not eclipse the role of the individual in perceiving, interpreting, and (re)creating those opportunities.

## **2.4. Review of social network studies of language**

Early on, Radcliffe-Brown (1940) singled out the study of language change in particular as a ripe site for a structural perspective on social phenomena:

---

<sup>16</sup> In order to accommodate the competing positions, theorists and researchers have formulated respective notions of *bonding* capital (constraint is beneficial) and *bridging* capital (diverse networks are beneficial), constituting a large and active area of research within organizational studies (see Adler & Kwon, 2002, for review), as well as in educational and other social contexts (see Portes, 1998).



[T]he spread of language, the unification of a number of separate communities into a single speech-community, and the reverse process of subdivision into different speech communities, are phenomena of social structure. So also are those instances in which, in societies having a class structure, there are differences of speech usage in different classes (p. 7).

Radcliffe-Brown thus draws a tantalizing, explicit link between social structure and linguistic style. Later, in a similar vein, Hymes (1974) argues extensively for an ethnographic approach to the study of language – one which stresses language as a social and cultural phenomenon, rather than a cognitive one. Emphasizing the centrality of “communicative events and patterns” in sociolinguistics, he evokes the network and the community as the essential context in which to investigate contextualized language use, rather than abstract, idealized language forms devoid of context.

One must take as context a community, or network of persons, investigating its communicative activities as a whole, so that any use of channel and code takes its place as part of the resources upon which the members draw... It is not linguistics, but ethnography, not language, but communication, which must provide the frame of reference within which the place of language in culture and society is to be assessed. (Hymes, 1974, p. 4)

Radcliffe-Brown and Hymes are therefore the first of many to root the study of language within the context of the community. However, in suggesting a network approach to sociolinguistic variation, researchers have continued to grapple with the issue of whether the speaker is a passive recipient of language forms, or an active user thereof.

In this section, I review the network studies as they have been applied specifically to language behavior. First, I review network studies of sociolinguistic variation, including both dialectal variation and shift, and bilingualism. Second, I review the bare handful of more recent network studies on L2 learners and L2 use, including qualitative studies in which networks are used as solely a

conceptual apparatus, as well as quantitative/computational studies in which actual network analysis is employed, though not in a very sophisticated manner.

#### **2.4.1. Sociolinguistic variation: Homogeneity or performance?**

Within the study of sociolinguistic variation, the classic tension between structure and agency takes center stage, paralleling that seen more generally within network studies (see Section 2.3.3). Early network studies of sociolinguistic variation were primarily interested in defining networks in objective terms, favoring an approach in which the individual is regarded as a subject whose language use is environmentally determined (i.e., social homogeneity). However, as notions of identity have become increasingly incorporated into later network studies, variation has come to be seen as a strategic choice in enacting a valued social identity (i.e. social capital). The individual is portrayed as an active participant who uses language (or dialect) for the accomplishment of personal goals.

#### ***Dialectal variation and shift***

Network analysis has been applied to sociolinguistic analysis perhaps most prominently by Lesley Milroy (1987) and her associates. Milroy (1987; see also Milroy & Gordon, 2003) employ their brand of network analysis to the analysis of sociolinguistic variation for several reasons. First, it enables researchers to pursue a fine-grained analysis within relatively small groups that would otherwise not be amenable to large-scale surveys focusing on social categories: analysis can be carried out on a small-scale basis. Second, it proves to be an appropriate method for studying groups in which social class – a mainstay of earlier sociolinguistic research – is difficult to apply, such as rural and migrant populations, among others. Third, the relational nature of the network approach permits investigation of the social dynamics involved in language variation and change.

In a seminal network study, Milroy and Milroy (1978) investigate dialect shift within working-class neighborhoods of West Belfast. Relying heavily on the notions of density and

multiplexity, they detail the “knittedness” of social networks found within these neighborhoods, including the level of interconnectedness among the residents, who often worked and socialized extensively with their neighbors. With few of these individuals coming into regular contact with people from outside the neighborhood, these close-knit networks resisted the introduction and diffusion of linguistic variants more effectively than did loose-knit networks.

Milroy and Milroy’s findings were at the forefront of a number of studies from the late 1970s through the 1990s which sought to link the close-knittedness of community members’ networks to the diffusion of the vernacular dialect (Cheshire, 1982; Russell, 1982; Bortoni-Ricardo, 1985; Lippi-Green, 1989; Edwards, 1992). Like Milroy and Milroy’s (1978) study, these researchers generally employ network scales and indices designed to capture features of the local network structure which reflect meaningful differences in local social practice (Milroy & Gordon, 2003).

However, the objectively-defined network scales often used in the earlier studies have not consistently proven satisfactory. Using the same technique as Milroy and Milroy (1978) in investigating individual usage of the local German dialect among residents of a small Austrian town, Lippi-Green (1989) reaches the conclusion that while readily observed network factors are crucial to understanding linguistic variation, they do not tell the whole story:

[N]either integration alone nor interaction of integration with age and gender will satisfactorily explain or predict behavior for [loyalty to conservative language norms] to the degree we would like to understand it. It is most likely that *subjective evaluation* of this variable plays an important, and as yet, inestimable role. (p. 231; emphasis added)

Following from this assertion, Edwards (1992) investigates Black English (BE) vernacular among residents of inner-city Detroit. He finds that that respondents who had favorable attitudes towards the community in which they lived were more likely to use linguistic variants of BE in accordance with community norms. More recently, Eckert (2000) has linked the use of linguistic variants within a

speech community of American high school students to their respective membership within informal, yet intersubjectively real social categories of “jocks” and “burnouts.” Use of particular linguistic variants is thus a marker of the category with which one identifies most strongly.

### ***Bilingualism***

The bevy of significant findings from network studies of dialect change underscores the intuitive appeal of extending methodologies to the study of bilingualism, language change, and language maintenance. This extension of the network approach is highly appropriate in settings where the bilinguals in question are members of relatively small communities of ethnic minorities. Accordingly, a number of studies have examined how bilinguals’ choice of language is constrained by the network relations.<sup>17</sup>

In a cross-generational study of Chinese immigrant families in Britain, Milroy and Li (1995) find that within each successive generation, individuals’ personal networks are increasingly integrated with the host culture, with corresponding patterns of interaction. This variation in network structure and integration with the majority culture results in different patterns in language choice within the Chinese community, ranging from primarily Chinese-only patterns, to Chinese-English codeswitching in varying levels of balance, and even to exclusive use of English between members of the youngest generation.

In examining language shift in a German-Hungarian bilingual village in eastern Austria, Gal (1978) makes a similar argument for central consideration of language as a marker of social identity. Gal links the decline in the prevalence of Hungarian within the community to attitudes and the presentation of self on the part of women, many of whom hold negative views of peasant life and wish to avoid assuming the associated social identity.

---

<sup>17</sup> Due to space constraints, I have limited my discussion to empirical networks. I forgo review of computational models which use social networks to simulate the dynamic, coexistence of competing language groups.

### ***Interim summary***

In all, those taking a network approach to linguistic variation generally agree that patterns of interaction constrain dialect and language choice, serving as a reliable indicator of patterns of language and style choice. The choice to use variants at one's disposal does not reside solely within the individual; it is limited by network structure. However, network studies of dialect/language shift have been split in terms of whether code use is viewed as an ingrained response to a situation or a strategic choice (Milroy & Gordon, 2003). While Milroy (1987) and other researchers adhering to an objectivist network approach acknowledge language as a marker of social identity, they refrain from explicitly integrating social identity into a causal structure. While not outright denying the operation of factors such as identity, they uphold a view of individuals' linguistic choices as determined by an objectively-defined social environment, very similar to that held by social homogeneity researchers more generally.

By contrast, findings such as those of Lippi-Green (1989), Edwards (1992), Eckert (2000), Gal (1978) and others highlight the potential limitations in employing the objectivist network approach to sociolinguistic variation offered by Milroy and others; one likely cannot thoroughly account for patterns of linguistic variation without considering its role in the enactment of sociocultural identity. According to Eckert (2000), these categories are relationally maintained through a tapestry of shared social practice, a component of which is the use of various linguistic variants (but also includes dress and participation in urban versus school activities). In this way, students become what they do (to paraphrase Eckert), using language strategically in order to choose and maintain a valued social identity. Linguistic style is therefore regarded as the "strategic, proactive use of available linguistic resources to construct social meaning" (Milroy & Gordon, 2003, p. 199).<sup>18</sup> Ultimately, this closely mirrors the agentic notion of social capital outlined above; individuals proactively use of available resources in performing and achieving personally meaningful aims.

---

<sup>18</sup> This notion of social construction of social meaning within a community is important one, and will be discussed further throughout the thesis.

#### 2.4.2. Network studies of L2 learning and use

Most relevant to the current thesis is a small body of more recent network studies which look explicitly at L2 learning and use. Unlike earlier swathe of network studies of sociolinguistic variation, these studies should be at an advantage in terms of navigating the conceptual tension between agency and structure. Such studies should have benefited considerably from the social turn in SLA (Firth & Wagner, 1997). The ensuing debate has prioritized discussion of L2 use as participatory, meaningful, and rooted in social context, thereby distributing a great deal of theorizing across the field as a whole. It is therefore puzzling, as de Bot and Stoessel (2002) note in the introduction to a special issue of the *International Journal of the Sociology of Language* devoted to the topic, that potentially fruitful network approaches to language use and acquisition have been so limited:

[O]ne of the paradoxes of the study of language and social networks [is that] while researchers agree intuitively that social networks should play a role in questions relating to language change, and several qualitative studies have shown what kind of role they play, there is little, if any, quantitative support for a direct relation between social-network characteristics and language use.” (p. 3)

Indeed, it appears that more recent network studies of L2 learning and use have suffered from the relative intractability of social network analysis as a single, cohesive field. As De Bot and Stoessel (2002) themselves note, a disunified social-network research methodology has resulted in a lack of uniformity and transparency.

These obstacles are reflected in the two main approaches to the network study of L2 learners. One is a quantitative-computational approach which, while attempting to employ formal analytical methods, often fails to do any more than offer cursory descriptions of network features, and simple demonstrations of a network method. The other is a qualitative case-study approach

which incorporates much-needed theoretical backing for a network approach, yet often refrains from employing actual network analysis, remaining confined to using networks as a purely conceptual apparatus.

### ***Quantitative-computational approach***

In a noteworthy study looking at both language maintenance and language acquisition, Cenoz and Valencia (1993) investigate Spanish (ethnolinguistic majority) and Basque (minority) speakers within a Basque region of Spain who are learning the other language as a compulsory L2. They examine various relationships between learners' social networks, L2 motivation, subjective ethnolinguistic vitality, and language achievement (L1 and L2). Among their findings is a structural equation model of acquisition of Basque as a L2, in which an individual's ratings of Basque competence within his/her social network are directly related to perceived ethnolinguistic vitality of the Basque community, L2 motivation (L2 attitudes; desire to learn the L2; motivational intensity), and L2 achievement. However, given their sampling technique of groups within schools, their measure of ego-centric social networks (which includes family, friends, classmates, neighbors) is likely to produce highly interdependent scores, with single individuals represented multiple times within the dataset. Nonetheless, Cenoz and Valencia subject each participant's scores to conventional statistical models based on assumptions of independent scores and normally distributed data. This has ramifications both measurement-wise and conceptually. From the standpoint of measurement, this introduces an elevated risk of type I error (Krackhardt, 1988). On a conceptual level, this treatment of context as independent erodes much of the value of a network approach, as it negates the possibility of investigating how individuals operate interdependently to form community structures which support and reinforce (or forestall) acquisition of the L2 and related attitudes.

Looking at L1 proficiency of Dutch immigrants to New Zealand and subsequent generations, Hulsen et al. (2002) found that the ratio of L1 Dutch-speakers to English-speakers within informants'

social networks was positively related to the use of Dutch both within and outside the family, proficiency in Dutch, and positive attitudes toward L1 maintenance. However, another crucial finding is that networks appear not to have a direct effect on language processing (as measured by reaction times to a picture naming task) beyond providing L1 input, though Hulsen et al. acknowledge the preliminary nature of these results.

Examining the social network structure of immigrant youths in Sweden, Wiklund (2002) attempts to draw conclusions regarding the impact of social network structure on a range of language proficiency measures, including use of nominalizations, the passive form in written composition, and various verbal-sophistication indices. Wiklund collects a sophisticated and extensive set of network data that includes density, multiplexity, and intensity (as measured by a range of social activities) in order to demonstrate the orientation of the students' network in relation to various nationality groups (i.e., host nationals, co-nationals, or other). Despite a seemingly rich data set, Wiklund does not provide any actual correlational data. Her suggestions that benefits to L2 proficiency associated with network orientation towards host nationals are thus impressionistic. Despite glaring limitations, the study does reflect the typically objectivist approach of network analysis in which observable patterns of (linguistic) behavior are analyzed against network structure.

Smith (2002) proposes a multiple case study methodology. Looking at "expatriates" living in Southeast Asia,<sup>19</sup> he offers an extensive ego-centric analysis of individual cases using conventional network properties. He collects an impressive array of network data, including multiplexity, interaction frequency, emotional closeness, reciprocity of ties, density of the ego network, and the form of social support derived from each tie. This rich dataset also permits Smith to produce a sociogram of each informant's ego-network, and analyze structures within (e.g., clique analysis). This is accompanied by two communication competence indices. Like Wiklund (2002), however, Smith

---

<sup>19</sup> The backgrounds of expatriates were not provided, though some were indicated to be American.



makes explicit quantitative comparisons between individual cases without any sort of correlational analysis, claiming associations between communicative competence and various network features merely by pointing to apparent but unverifiable relations between quantitative variables. Given the scope of the article, Smith omits accompanying ethnographic interview data. This is unfortunate, as the two could have been used fruitfully in combination, with the sociometric analysis supporting qualitative assessments of processes that unfold along network ties. Therefore, while Smith offers a valuable and much needed demonstration of modern sociometric network analysis, the study falls well short of offering empirically supported conclusions.

The main advantage of a quantitative-computational approach (the approach taken within this thesis) is its roots in the common mathematical language of graph theory, which lends these studies a measure of analytical unity. In particular, Wasserman and Faust (1994) note that network analysis provides “explicit formal statements and measures of structural properties” (p. 17). However, these methods are also a disadvantage. First, they can often be onerous, not only in their arcane computations, but in their data completeness requirements. As a result, obtaining information about a single individual’s ego-network can easily go well beyond a typical questionnaire, involving a great deal of effort on the part of the researcher. Second, as mentioned, the link between graph theory and network analysis has often led to the atheoretical transfer of graph-theoretical concepts, which network theorists must subsequently formulate theory to support (e.g., Borgatti, 2005). A quantitative-computational approach is therefore limited in terms of what it can explain in terms the actual social processes that actually unfold along the ties – or precisely *how* networks matter. This depends largely on more qualitative approaches.

### ***Qualitative case-study approach***

A number of recent studies have taken a qualitative, case-study approach, focusing in on individuals and their ego-networks. While these studies generally lack the rich detail of network description that a quantitative-computational approach provides, they do provide important insight

into the actual process of L2 learning as it occurs across social ties. The central concern within these studies is the learner's access to various resources that help the individual meet the personal goals related to acquiring the L2, and functioning within a foreign culture. As a whole, these studies embrace the view of language learning, use, and identity as socially constructed (e.g., Lave & Wenger, 1991; Williams & Burden, 1997). Studies generally share a common viewpoint with the community of practice approach in that the learner is viewed as a "whole person, rather than 'receiving' a body of factual knowledge about the world" in which "agent, activity, and the world mutually constitute each other" (Lave & Wenger, 1991, p. 33).<sup>20</sup>

Accordingly, a Vygotskian notion of mediated learning (e.g., Lantolf & Thorne, 2007) is often adopted in order to explain how knowledge is co-constructed in the relationships between the learner and others before it becomes internalized. It is through a scaffolding process with more capable others that the learner internalizes the L2. This development in communicative competence is tied to the learner's growing ability to use the L2 as a flexible between the environment and basic needs. This approach therefore addresses the social construction of traditional concepts within L2 motivation research, such as identity, motivation, attitudes, and so on. As Pavlenko (2002) notes, "such seemingly internal and psychological factors as attitudes, motivation or language learning beliefs have clear social origins and are shaped and reshaped by the context in which the learners find themselves," (p. 280-281).

The most extensive employment of this approach has been undertaken by Kurata (2004; 2007; 2011). Through a series of case-studies, she examines how L2 learners co-construct learning opportunities. This co-construction is characterized by the creation of an anxiety-free interpersonal

---

<sup>20</sup> However, in contrast to the community of practice approach, its focus, while not atomistic, does rest on the individual and the personal network of immediate social ties. The aim is to examine the individual's various interactions in various contexts, rather than focusing on the activity of an entire group.

space<sup>21</sup> in which the learner feels free to practice the L2, make mistakes, and learn accordingly. The strong ties therefore provide learning opportunities for the L2 speaker. For instance, Kurata (2007) examines opportunities for L2 use and learning within the interactions of a learner of L2 Japanese studying in Australia. Through interviews and analyses of online chat interactions, she finds that the learner's identity as an adequate user of the L2 was a mutually agreed-upon affair between the learner and an interlocutor. When agreed upon, this space facilitated L2 learning opportunities. By contrast, when this identity was impugned through interactions with more capable native speakers, L2 use was impeded.

Ferenz (2005) looks at how social networks impact the acquisition of advanced L2 literacy and composition skills. She holds that advanced L2 literacy requires an array of knowledge that is gained through various socialization processes enacted across social relations that are patterned by social institutions such as the university and its departments. Through qualitative interviews with Israeli university students participating in EFL academic writing courses, she investigates the relationship between the composition of the students' network of individuals with whom they discuss L2 writing tasks, and their desired social identity and future goals. She reports that individuals' differing orientations towards their academic versus nonacademic networks reflect their respective desired social identities (academic versus professional). In particular, those oriented towards their academic network and an academic identity reported a more organized, systematic pattern of decision-making when writing.

Looking at female learners of L2 English living within the United Arab Emirates, Palfreyman (2006) takes an ecological viewpoint in focusing on the "social infrastructure" of common material and social resources embedded in the social ties around the language learner. Access to these resources is regarded as essential learning opportunities. He outlines a rich variety of material

---

<sup>21</sup> As Kurata (2007) notes, this notion of space is very similar to Vygotsky's notion of the Zone of Proximal Development (ZPD) (see Lantolf & Thorne, 2007).

resources that students value to various degrees (e.g., technology), as well as prominent social sources of help with learning. An interesting finding is the mention of highly proficient older sisters who remain in the country as particularly valuable resources. Not only does this help-seeking contribute to a reaffirmation of a traditional, gendered identity oriented towards the family, it also emphasizes the interdependence of social roles, with learners later becoming resources themselves. In all, Palfreyman is laying the groundwork for a connectionist model of access to learning resources. Still lacking from studies such as these, however, is a direct investigation of differential access to resources/opportunities, and how these impact the use and/or learning of the L2.

Dörnyei et al. (2004) look at the relationship between learners' participation in host-national and co-national networks, and their acquisition of formulaic sequences<sup>22</sup> in the L2. They view the acquisition of formulaic sequences as a socially constructed process requiring "'tapping into' the sociocultural reality of the L2 community and incorporating elements of it into the learners' own language behavioural repertoire" (p .87). Based on a series of case studies of international students studying at a British university, they tentatively advance that learners' integration into host national networks may serve as a strong moderating factor between motivation and aptitude, and the development of L2 formulaic sequences, reflecting the power of acculturation on L2 proficiency.

Isabelli-Garcia (2006) presents the case studies of four American learners of L2 Spanish studying abroad in Argentina. Through use of contact diaries and interviews, she traces the development of their host national social networks alongside fluctuations in integrative and instrumental motivation (Gardner, 1985; Gardner & MacIntyre, 1991), as well as their progressive acculturation from ethnocentric to ethnorelativistic attitudes. She considers their joint impact on L2 oral proficiency. Over the course of a semester abroad, the informants experience changes and fluctuations in motivation orientation, attitudes, and identity which are explained in terms of the

---

<sup>22</sup> According to Wray (2002), a formulaic sequence is "a sequence, continuous or discontinuous, of words or other elements, which is, or appears to be... stored and retrieved whole from memory at the time of use, rather than being subject to generation or analysis by the language grammar" (p. 9).

development of the learners' social networks. She concludes that those learners who are able to integrate into host national networks sustain their motivation more effectively and mature further in their acceptance of cultural differences, thus permitting further development and maintenance of their social network, and ultimately resulting in enhanced L2 oral proficiency.

Overall, the case-studies approach provides essential analysis of the micro-behavioral processes that actually occur over social ties, leaving their mark on learners' L2 proficiency, attitudes, and identities. The general view is that these ties serve to connect the learner into the social reality of an L2 community which is continually re-created over these ties. Furthermore, the approach is more amenable to the realities of data collection, allowing researchers to focus on what they have, versus what they missed out on. Insights and much of the general theoretical background to these studies will be highlighted throughout this thesis to illuminate the underlying social processes.

However, there are a number of related limitations. First and foremost, the level of actual network data in these studies is, for the most part, unnecessarily scant. None of the qualitative studies approach the data richness of quantitative-computational studies, such as Smith (2002). This proves detrimental to their arguments regarding changes in L2 competence and attitudes over the course of the interactions. For instance, Isabelli-Garcia (2006), a laudable exception to this pattern, uses sociograms and second-order networks (i.e., friends-of-friends) to some effect in her explanations of the evolution of personal networks over time, and how the formation/existence of one tie leads to formation/existence of another. This crucial aspect of network analysis is absent in most other qualitative studies, which often present network descriptive statistics seemingly as background. As such, the 'network' becomes a way to talk about mere sums of direct interactions, rather than as a means of investigating the emergent properties resulting from an interaction being situated in a wider community of interdependent actors.

Consequently, the use of the word 'network' at times seems arbitrary in these studies, becoming a metaphorical device rather than a measurement construct. Lost is the ability to subject network data to statistical analysis. More importantly, however, in the absence of formal unifying constructs, a 'network approach' tends to become highly fragmented, idiosyncratic, and unsystematic in its application, likely impeding its widespread adoption.

## **2.5. Conclusion: Towards a network approach to L2 learning and use**

In summary, a general social network perspective is underpinned by a handful of underlying assumptions: the relation is the basic unit of analysis. Actors/nodes are fundamentally interdependent in their action, not autonomous. Relationships are sites for the exchange of symbolic and material resources. Regular patterns of interaction both constrain and enable individual action. Attributes such as gender, class, and ethnicity are more appropriately defined in relational terms, rather than as categories. Beyond these assumptions, however, a social network perspective has been marked by a general lack of cohesiveness resulting from its disparate, diverse history over several decades, with roots in various subdisciplines of the social sciences, as well as mathematics.

Despite this general vagueness of a network perspective, as seen within this chapter, one can differentiate a more specific notion of social network analysis from more general appeals to the concept of the social network. The main advantage of this computational approach is the unifying power of its formally-defined constituent concepts that are rooted in graph theory. Offered is an array of notions – including notions of centrality, cohesion, and role equivalence – which yields rich descriptions of structure that can be parsimoniously applied to a wide range of social environments. The main disadvantage is that its focus on system has come at the expense of theory, including a suitably sophisticated treatment of the individual. Allied theories, including social exchange theory, have traditionally defined agency either in simplistic instrumentalist terms, or eschew it altogether in favor of deterministic explanations (Emirbayer & Goodwin, 1994; Robins & Kashima, 2008).

Yet, network analysis itself is not so theoretically dogmatic. Behaviorist/rational choice accounts may be favored as a quick, parsimoniousness assumption that satisfactorily accounts for human action, letting the sociologically-minded researcher get on with his or her primary task of describing social systems. However, for those interested in the precise intersection of the social and psychological (as I am), one must formulate a rapprochement between structure and agency. As noted, a handful of theorists and researchers have done this by generally offering the notion of social relationships as sites of *opportunity* to exercise motivated action – action which may in turn recreate or change the underlying structure itself.

Building an adequate account of network theories of individual behavior therefore requires importation and integration with complementary theories in psychology which address behavior when faced with the opportunity to do so. While social psychological theories should offer an account of the *situated* behavior, network analysis offers a parsimonious explanation of *systematic/structural differences* in opportunities to exercise one's will. The challenge for any nascent network theory of human behavior thus lies not in replacing social psychological theories, but in complementing them in such a way as to “retain the distinctiveness of social network emphases on patterns of relations, multiple levels of analysis, and the integration of graphical and quantitative data,” (Kilduff & Tsai, 2003, p. 64).

Therefore, while adequately delineating the complex interplay between the agent and the social structure remains a challenging theoretical issue (see Dörnyei, 2009a), there is no reason why the task of incorporating various frameworks of situated L2 use with network analysis cannot begin. In particular, as seen in Chapter 3, the willingness to communicate in the L2 (L2 WTC; MacIntyre, *et al.*, 1998) – as a theory of *purposeful* L2 use *given the opportunity* – is a prime candidate for integration with network analysis.

As a framework of *purposeful* L2 use, the L2 WTC model highlights the speaker's agency, thus fitting comfortably within the larger social turn within SLA (Firth & Wagner, 1997; 2007; Larsen-Freeman, 2007a). Indeed, as already seen within the qualitative case-study network approach, a network approach that seeks to affirm the agency of the L2 learner/user must also generally endorse the fundamental importance of communicative competence, in which non-native speakers accomplish personal goals in spite of their linguistic errors (see Hymes, 1972; Canale & Swain, 1980; Firth & Wagner, 1997; 2007).<sup>23</sup> Indeed, the study of cross-cultural sojourners in Chapter 4 explores the notion of L2 WTC as an aspect of the motivated effort to function effectively within one's new cultural surroundings, and the opportunities, threats, and challenges faced therein.

However, such purposeful L2 use is conceptualized as fundamentally *relational* in nature. In supporting a view of L2 use, Firth and Wagner (2007) emphasize the importance of "learning-in-and-through-social-interaction." Derived from constructivist views on learning in which learners actively construct knowledge and personal meanings through doing, rather than receiving (Williams & Burden, 1997), social-interactionist accounts of learning stress that learning and social practice are inseparable (e.g., Lave & Wenger, 1991). As discussed throughout the remainder of this thesis, the notion of humans as actively sharing meanings and intentions within social interactions is a key facet in the emergence of language, and the language learner's use of the L2 to actually serve his or her purposes.

In addition, as a framework of situated L2 use, *given the opportunity*, L2 WTC also fundamentally poses the issue of social structure. As Passy (2002) notes, ingrained social values and beliefs will not manifest themselves as behavior unless the individual possesses the *opportunity* to

---

<sup>23</sup> Conversely, if one wishes to focus on L2 acquisition and language as a mental construct (Long, 1981; 1996), network analysis could feasibly be utilized as a measure of (modified) input. However, unless accompanied by a notion of motivation, such an approach would still be subject to the same criticisms of determinism.



enact them. Indeed, as I argue in Chapter 5, appealing to L2 use merely as 'relational' contributes little (by itself) towards explaining the systematicity of L2 opportunities. Rather, relational behavior between two or more individuals (such as interpersonal communication) must be understood with respect to the surrounding structure of routine social interactions that provides individuals with regular and predictable opportunities for interaction.

Despite its importance, however, a systematic treatment of person-to-person disparities in opportunity is precisely what has been missing from conceptualizations of language motivation and use. As seen in the following chapter, the body of research in contextualized language use makes a leap from macrosocial theories of language maintenance and shift, to situated language use within an encounter. These approaches have generally held opportunities as equal, either by holding them constant within an experimental setting, or by assuming them to be approximately equal by virtue of group membership. They explain little in terms of the likelihood of an encounter, how an encounter came about, or the choice to enter into the encounter. Rectifying this gap will be the central focus of the network study in Chapter 5.

Purposeful L2 use within structure may be explained using the common metaphor of a dance. As a form of social interaction, L2 communication is like an unchoreographed routine in which dance partners creatively and delicately react to one another (e.g., Shanker & King, 2002; Thompson & Valsiner, 2002). Knowledge of an individual dancer's skills and tastes will not go very far in predicting every twist and turn that she makes. Rather, dancers use one another as improvisational tools in the enactment of a larger performance with various meanings and levels of significance. Moreover, those who dance together routinely are better able to enact these meanings with each other. It is in this way that individuals achieve personal goals through communication with others. However, the dance metaphor may be taken further, evoking an exchange network replete with contingencies. Most notably, dancing with one partner entails not dancing with another. Out of this, a hierarchy emerges in which there are winners and losers, with some having a slew of potential

dance partners, others having few, and some having no opportunities to dance at all. The contingent nature of encounters captured by network analysis is therefore essential to describing the unequal nature of human agency; that is, who has the regular opportunities to achieve one's goals, and who does not.

In conclusion, social network analysis holds a much needed perspective in pointing out that L2 learning and use is meaningful and agentic, but such agency occurs within (systematic) limits. L2 learning is not only relational, but also interdependent and systemic. L2 use is not just socially conditioned, but also relationally enacted and re-enacted. If agency is indeed realized in the dance of social interactions, a network approach provides with one way of examining the dance floor, and who gets to dance with whom.

## Chapter 3

### Willingness to communication in the second language (L2 WTC)

#### 3.1. Introduction

In the previous chapter, I reviewed in some detail the general precepts, development, methods, and applications of social network analysis. With social network analysis often accommodating or, indeed, necessitating importation of theories from other fields, I argued that network analysis may be fruitfully integrated with a framework of purposeful L2 use. I posed *willingness to communicate in the second-language* (L2 WTC; MacIntyre, *et al.*, 1998; hereafter MCDN) as a prime candidate for just such a framework, regard network analysis as a possible means by which to conceptualize an accompanying structural notion of ‘opportunity.’ By viewing social relations as an opportunity for motivated, meaningful action, we come closer to an account of the L2 learner/user as an agent who is fundamentally embedded within a social context, but not unquestioningly beholden to determinative forces.

In the current chapter, I review the theoretical background and empirical findings within the body of L2 WTC research. Seen as the psychological “readiness to enter into discourse at a particular time with a specific person or persons, using a L2” when presented with an opportunity (MCDN, p. 547), L2 WTC is conceptualized as a dynamic, fluctuating, situated variable that rises and falls as internal factors and external influences interact. However, in practice, L2 WTC has typically been treated as a more-or-less stable disposition, with studies focusing on the distal and immediate influences of various psychological antecedents to trait-like L2 WTC (MacIntyre, 2007). In concentrating on the cognitive, affective, and motivational processes of L2 WTC, these studies have neglected the original, dynamic character conceptualized by MCDN. However, in recent years, researchers have increasingly turned their focus to the situated rise and fall of L2 WTC within

interaction. Neither set of studies, however, has devoted much attention to a systematic account of L2 opportunity.

In proceeding with the review, I focus in particular on two aspects of MCDN's conceptualization of L2WTC as a psychological readiness to enter into discourse using the L2. First, I concentrate on L2 WTC as 'readiness,' as found within what I term the *psychological antecedent strand* of L2 WTC research. Taking a more traditional, hierarchical viewpoint, studies within this strand commonly seek to describe the cognitive, affective, and motivational workings of the contextualized human mind that culminate in an intention to use the L2.

Next, I focus on the 'discourse' that L2 users are entering into, as found within the *social co-construction* strand of L2 WTC research. As Williams and Burden (1997) note, "an understanding of the workings of the human mind is not in itself adequate to explain what goes on when we learn something" (p. 39). Accordingly, studies within the social co-construction strand therefore take a more cyclical perspective, with L2 WTC and L2 use seen as both shaped by and giving shape to, the social reality in which learners operate and strive towards personal goals.

In essence, these strands differ in terms of how they address the following question: Where does the story of L2 WTC and L2 use end? For the psychological antecedents strand, the analytical goal is to predict L2 use, simply defined. Little attention is paid towards the meaning of that use. By contrast, in the social co-construction strand, researchers have sought to describe more precisely the meaningfulness of L2 communication as shared by communities of learner/users. L2 use is thus regarded as purposeful, rather than as an end in itself.

Lastly, it is noteworthy that while the split between these strands approximates the division between studies of trait-like and situational L2 WTC, it does not adhere to it exactly. Indeed, as will be seen, investigations of trait-like WTC that overlap with a social constructivist perspective are crucial to formulating a network approach to the study of L2 WTC, offering a number of important

structural insights to an interactive learning process resulting in trait-like L2 WTC. Ultimately, a network approach is the most conceptually fruitful approach for describing the learner's immersion within a social reality mediated by the L2.

### **3.2. L2 WTC as disposition: The psychological antecedent strand**

MCDN put forward the L2 WTC as the *intention* to communicate in the L2. Searle (1995) defines intentionality as “the capacity of the mind to represent objects and states of affairs in the world other than itself.” In proposing the L2 WTC model, therefore, MCDN accept intention as the combination of a desired future state of affairs, and a plan of action for achieving that goal (i.e., communicative competence). Authentic communication in an L2 occurs when a latent desire to communicate in the L2 with a certain person at a certain time meets with an opportunity to do so, leading the individual to initiate a plan of action for actualizing that desire (see also Dörnyei & Ottó, 1998). However, MCDN's model also emphasizes the complex interplay of cognitive, affective, and motivational factors in producing this desire and the temporary state of confidence to pursue it. In the current section, I discuss several key theoretical foundations of the model in L1 WTC and behavioral intention. This is followed by an outline of the pyramidal heuristic advanced by MCDN which details the various distal-to-immediate psychological antecedents of L2 WTC. Finally, I provide a review of empirical studies which have sought to describe the complex system of interrelated variables specified within the L2 WTC model.

#### **3.2.1. Theoretical framework**

##### ***L1 WTC***

Drawing on previous constructs such as *unwillingness to communicate* (Burgoon, 1976) and other personality constructs related to a general tendency to enter into interpersonal communication, McCroskey and Baer (1985) advance the notion of *willingness to communicate* (L1

WTC)<sup>24</sup> to describe a general predisposition towards verbal communication. From the outset, a primary issue that has garnered much attention within the literature has been whether or not the construct is indeed a personality-like trait. As McCroskey and Richmond (1990a) note, “[u]nderlying the WTC construct is the general assumption that it is a personality-based, trait-like predisposition which is relatively consistent across a variety of communication contexts and types of receivers,” (p. 23). They cite support for this assumption a number of studies that show a correlation between the tendencies to communicate across situations, with scales of WTC showing high internal reliability (McCroskey & Baer, 1985).

McCroskey and Richmond (1990a) therefore advance L1 WTC as a trait-like tendency across situations, predisposing the individual to communicate (or not). However, they are quick to adopt an explicitly interactionist viewpoint. They maintain that an individual will not be equally willing to communicate in all situations (see also Funder, 2006). Rather, situational constraints do influence the observed amount of WTC and ultimate communication behavior. However, McCroskey and Richmond’s emphasis is on the dispositional nature of WTC, with communication behavior correlated across situations.<sup>25</sup> Therefore, rather than investigating which specific situational constraints that elicit or dampen observed willingness, studies of L1 WTC have tended to focus on correlated communication-related ID variables (e.g., personality traits, perceived communicative competence, communication apprehension) that condition trait-like WTC, or to treat WTC as an independent variable in predicting organizational performance outcomes (Richmond & Roach, 1992).

Given this focus on L1 WTC as a disposition, consideration of the influence of context has therefore largely remained at a macrosociological level, focusing broadly on entire national cultures,

---

<sup>24</sup> McCroskey and his fellow WTC researchers do not explicitly address their construct in L1 versus L2 terms. However, their research focuses on WTC in general, and addresses WTC exclusively in L1 settings.

<sup>25</sup> This view led to the construction of the WTC scale (McCroskey & Richmond, 1987), which assesses an individual’s willingness across various situation types (one-to-one, small group, large group, and public speaking) and receiver-types (friends, acquaintances, and strangers).

rather than more situated contexts found within these cultures. For instance, McCroskey and Richmond (1990a; 1990b) maintain that the influence of culture on WTC is best viewed in terms of the social structure that contains these communication norms, and how that structure constrains the ingroup-outgroup communication patterns of its members. More specifically, they attribute cross-cultural differences in WTC and other communication variables to differences in cultural hierarchy and homogeneity (i.e. “dominance” and “divergence”). Although offering no specific theorems, they see cultural patterns of WTC as being different in a homogenous society marked by a single, dominant cultural group (such as Japan), versus a more pluralistic society containing many subcultures. Members of minority groups find themselves compelled to adopt the communication norms of the larger group(s) in order to function effectively. This adoption of the communication norms of the majority affects trait-like WTC if the person regularly comes into contact with the other culture. As such, they adopt a perspective that is strikingly similar to intergroup theorists, who generally posit that cultural homogeneity/heterogeneity will impact communication patterns (e.g., Giles, *et al.*, 1977; Schumann, 1986).

### ***Behavioral intention***

Wishing to capture a notion of *planned* L2 use in tandem with how such planning might be thwarted by the situation, MCDN conceived of L2 WTC with theories of behavioral intention in mind, most notably the *theory of planned behavior* (Ajzen, 2005), as well as its predecessor, the *theory of reason action* (Fishbein & Ajzen, 1975). The theory of planned behavior in particular has one straightforward goal – to explain why people sometimes act in accordance with their attitudes, and sometimes do not. To do so, it relies on an assumption of volitional control - or the freedom from constraints in choosing a course of action.

According to the theory of planned behavior, behavioral intention is a willingness and ability to behave in a certain way. As the immediate antecedent of an actual behavior that is under volitional control, it is the culmination of three main factors: positive attitudes towards the

consequences that the behavior would bring about; subjective norms regarding how the behavior is viewed by significant others; and perceived behavioral control, or the belief that one can bring about the desired consequences of the behavior (see Figure 3.1). In turn, intention predicts actual behavior. An important aspect of the model, however, is that the relationship between intention and actual behavior will be less within situations in which *actual* behavioral control over the situation is diminished. Accordingly, a direct, positive relationship to actual behavior from perceived behavioral control exists within the model, as *perceived* control is seen as a proxy for *actual* control.

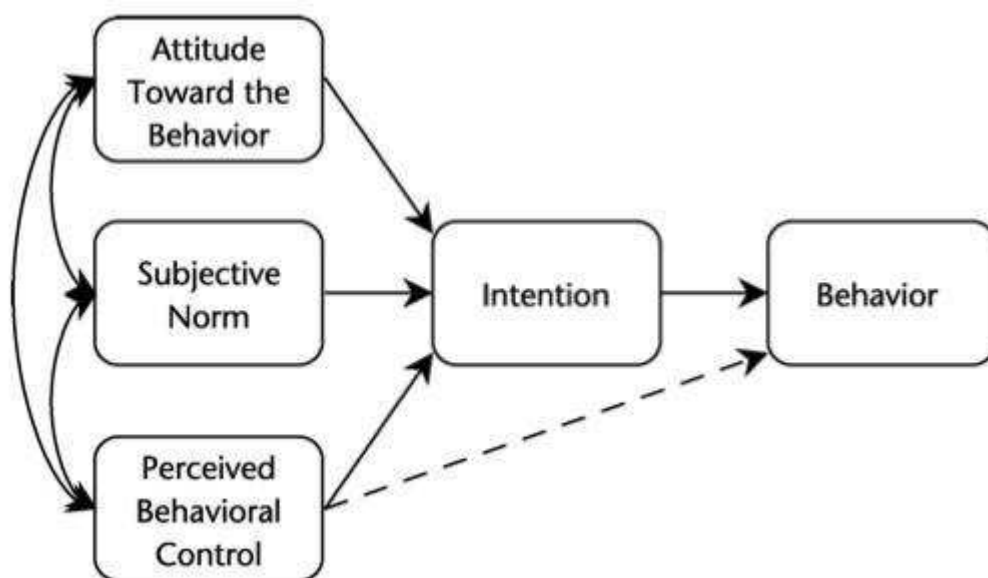

**Figure 3.1.** Theory of Planned Behavior, from Ajzen (2005, p. 118).

A trait-like conceptualization of L2 WTC thus flows directly from its association with Ajzen’s (2005) theory of planned behavior and with L1 WTC. Both the theory of planned behavior and L1 WTC focus on behavioral dispositions in which behavior is highly correlated from situation to situation. This corresponds with Ajzen’s assertion of a general consistency of psychological variables as well as the resulting behavior, in turn allowing him to proceed with disposition-based explanations of behavior:



A dispositional explanation of human behavior presupposes a degree of coherence among thoughts, feelings, and actions. If people's reactions toward a given target were completely inconsistent across time and context, we could not attribute them to such stable underlying dispositions as attitudes or personality traits. (Ajzen, 2005, p. 24).

However, such a view could pose Ajzen with the theoretical task of linking relatively stable psychological phenomena (e.g., personality traits, attitudes, etc.) to situated phenomena (i.e. behaviors) that can vary much more markedly. This disjunction poses an empirical challenge: if a successful theory is in part one that can make predictions, how can one predict a single instance of a situated behavior from a fairly limited set of stable attitudinal variables with any level of accuracy?

Ajzen does not so much resolve this issue as preempts it. He pushes aside the endless search for all the determinants of a particular instance of behavior,<sup>26</sup> arguing that single instances of a given behavior are ultimately not of much analytical concern:

Many instances of human behavior are 'overdetermined' in the sense that a multitude of factors combine to produce them. However, it is not the role of the psychologist to account for unique instances of human action... Of concern to the psychologist, therefore, are *regularities* in behavior, consistent *patterns* of action, response *tendencies*. (Ajzen, 2005, pp. 70-1, emphasizes original)

He argues that instead of focusing in on a single instance of a behavior, one should consider a behavior or a class of behaviors in aggregate. Repeated observations should be made on a number of occasions, allowing for situational determinants of the behavior to cancel one another out.

---

<sup>26</sup> Ajzen (2005) terms this the "moderating variables approach," which sought out every variable that moderates the relationship between dispositions and a given instance of a behavior. He notes that the list of such influencing variables is endless; each new moderating variable will only create yet another subpopulation for which yet another moderating variable must be found.

This move, however, has a major impact on the treatment of opportunity and context. First, Ajzen (2005) discusses opportunities as exogenous events that permit performance of independent behaviors which require little if any form of social cooperation. He cites the examples of seeing a play or donating blood. The intention to see a play (itself an exogenous event likely not under control of the individual) is futile if there is no play currently running. Second, Ajzen discusses behaviors that rely on cooperation with a willing alter. He uses the example of a husband wishing to have children with his wife. Here, Ajzen assumes that the interdependence of one individual on another individual is a constant. He does not account for the fact that individuals may have different numbers of alters with whom he/she can engage in the interdependent behavior, thus reducing dependence on a *particular* other. It is for this reason that Liska (1984) criticizes Fishbein and Ajzen's (1975) treatment of volitional control for its "false [singular] dichotomy" of volitional versus avolitional behavior. Liska argues that volitional control is much more of a dual spectrum, with different behaviors requiring various gradations of both social cooperation and required skill. Ajzen (2005) responds by positing a spectrum of volitional to avolitional behavior, though he does not offer any framework for this spectrum.<sup>27</sup>

In sum, Ajzen (2005) does not incorporate any sophisticated treatment of the ways in which situational constraints may facilitate or dampening actual behavioral control. He maintains that a dispositional viewpoint circumvents much of the need to consider opportunity, or lack thereof. He argues that psychologists should not seek to predict a single instance of behavior, but rather, general tendencies. He crucially assumes that "[b]ehavioral tendencies across occasions are relatively unaffected because appropriate opportunities are likely to be present on at least some occasions" (p. 109). In this view, individual opportunity is the result of either random events (and thus reducible to error), or as an intrinsic, constant aspect of the behavior itself and thus equally applicable to everyone within the setting of the study. Opportunity is assumed to be controlled for. Every

---

<sup>27</sup> By contrast, such a framework is offered within the interdependence theory of Kelley and Thibaut (Rusbult & van Lange, 2003).

individual who engages in a behavior is assumed to face the same level external constraints on volitional control.

Consequently, Ajzen's (2005) theory, unlike a network approach, does not explicitly treat 'opportunity' as a potentially systematic difference between individuals. While both a network approach and the theory of planned behavior view behavior as inherently regular, a network approach focuses on how interpersonal regularities in communication – when joined up within a network configuration – serve to provide individuals with different levels of access to various alters. Control over interpersonal communication is inherently limited, requiring a cooperative interlocutor. By virtue of social position, some individuals have a greater number of regular interlocutors than others, and therefore possess more opportunities and options in communicating.

### ***The pyramidal heuristic***

AS MCDN note, “[a]uthentic communication in a L2 can be seen as the result of a complex system of interrelated variables” (p. 547). They accordingly offer a pyramidal heuristic model of L2 WTC composed of various “layers” of personal and situational variables that coalesce and interact to compel a person to use the L2, or refrain from doing so (see Figure 3.2). These variables are generally separated into two categories: confidence with one's L2 abilities; and relational variables pertaining to motivation or tendency for interpersonal interaction. The former relates to one's relationship with the L2 itself, while the latter focuses on one's complex relationships with various individuals and groups (MCDN). These two families of variables, however, are internally differentiated according to the immediacy of their impact on L2 WTC and L2 communication, moving from latent predispositions to transitory, situated antecedents.

### **Layers I and II: L2 use and L2 WTC**

The topmost layer is actual use of the L2. MCDN treat L2 use in the broadest sense, encompassing interpersonal interaction in a L2 – either naturalistic or in the classroom – as well as

the use of various forms of mass media in a L2 (e.g., movies, newspapers, etc.). In their view, cultivating a tendency to search for opportunities to use and communicate in the L2 should be the primary goal of communicative second-language programs. The second layer represents L2 WTC itself. This is the level of behavioral intention – the immediate antecedent to actual performance of a behavior (Ajzen, 2005). Crucially, MCDN highlight the conceptual distinction between L2 WTC and the opportunities to use the L2: “This definition [of L2 WTC] provides that although the opportunity to communicate will likely present itself, it is not absolutely necessary in order to possess the WTC” (p. 547). However, MCDN do not go much beyond this in theorizing about behavior and intentionality.

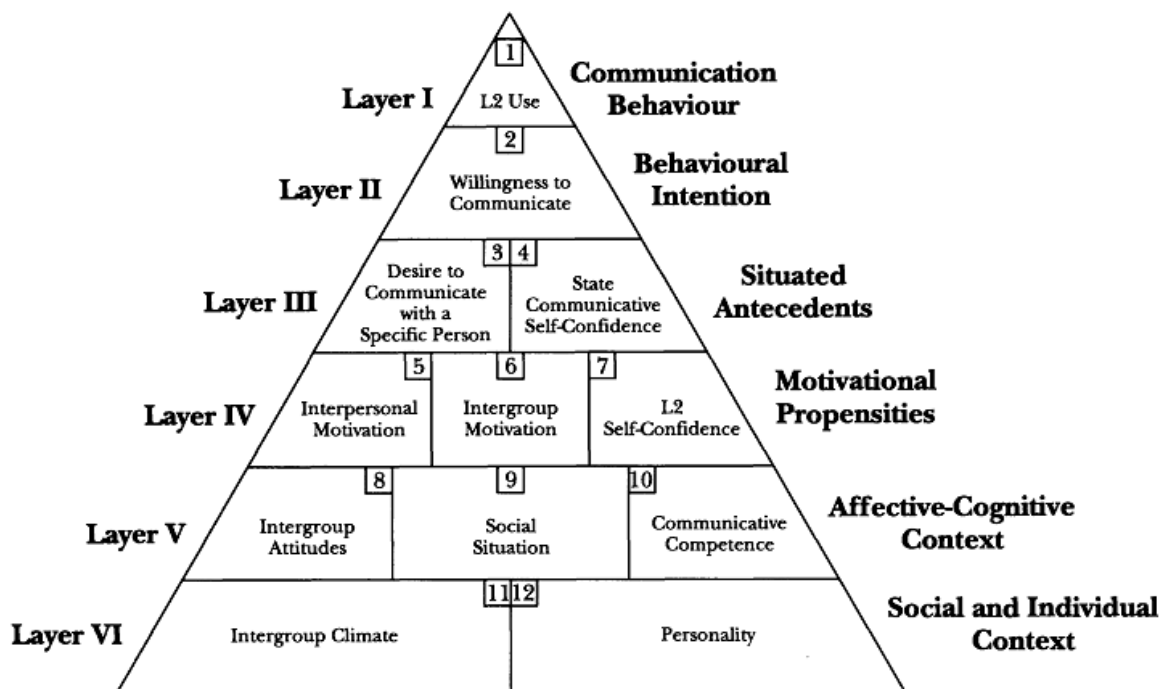

**Figure 3.2.** Pyramidal heuristic model of L2 WTC, from MacIntyre, et al. (1998, p. 547).

### **Layer III: Situated antecedents of communication**

The third layer of the L2 WTC model is that of “situated antecedents of communication,” consisting of two components. The first is “the desire to communicate with a specific person,” evoked by factors including but not limited to the social status and attractiveness of the

interlocutor(s). In this way, emphasis is placed on interpersonal interaction, focusing on joint performance of a behavior, rather than independent learning activities (despite MCDN's broad-based conceptualization of L2 use). MCDN rest their explanation of this factor on two basic motives: to affiliate with and/or to control one's alter. The control-affiliation dichotomy is one of a number of taxonomies describing humans' basic psychological needs innate to all humans from birth.<sup>28</sup> The motivation to perform a given activity is seen as arising out of these needs (Deci & Ryan, 2000). Through a gradual process of socialization, individuals come to identify certain activities more and more closely with the satisfaction of these basic needs. This process leads to the individual developing an internalized motivation to engage in these activities.

The second situated antecedent is *state communicative self-confidence*, conceptualized as the potentially impermanent feeling of confidence which can vary markedly across situations or even across the time-span of a single situation. It is the situational form of the trait-like L2 self-confidence originally put forth by Clément (1980; see Layer IV). It is conceptualized as consisting of both a cognitive and an affective component: the self-evaluation of one's skills and the negative emotional arousal experienced in using or learning the L2 (state L2 anxiety). State communicative self-confidence arises in the face of an opportunity for L2 contact. The underlying assumption is that deficits in domain-specific L2 skills, and negative prior experiences within similar situations, will directly dampen a speaker's intention to initiate communication using the L2, even when the desire to do so is present.

---

<sup>28</sup> For example, in order to explain how behaviors with socially constructed origins become integrated into the learner's sense of self and thus intrinsically motivating and self-sustaining, Deci and Ryan (1985; 2000) assume the existence of basic needs for competence, relatedness, and autonomy. Cialdini and Goldstein (2004) maintain that individuals are driven towards conformity and compliance within their social groups out of two goals: a desire to form an accurate perception of social reality; and a desire to form meaningful social relationships. Kadushin (2002) draws on psychodynamic theory in theorizing how basic drives for efficacy and security influence the network locations that one seeks out.

#### **Layer IV: Motivational propensities**

Layer IV refers to “motivational propensities,” which MCDN describe as more enduring individual differences that cut across situations. They note three in particular: interpersonal motivation, intergroup motivation, and (trait-like) L2 self-confidence. It is out of these propensities that the state variables described in Layer III emerge. MCDN once again appeal to control and affiliation motives, but as relatively stable interpersonal/intergroup orientation, rather than momentary impulses. The distinction between the two depends on whether the desire is directed towards someone as an *individual person*, or as a *representative* of his/her ethnolinguistic group.

On an interpersonal level, the control motive is seen as conditioned by relatively stable hierarchical social roles between individuals. Meanwhile, the affiliation motive is regarded as the tendency to commit to enduring relationships with others. Intergroup motivation, on the other hand is most salient in situations in which group identities are activated (see Turner, 1981), with group hierarchies, rather than interpersonal ones, holding more influence.

L2 self-confidence is defined as the belief in one’s “capacity to use the second language in an adaptive and efficient manner” (Clément, 1986, p. 273). It is keenly tied to the frequency and quality of contact with the L2, and is therefore thought to exert most influence on L2 behavior in situations where contact with the L2 is likely. Whereas intergroup and interpersonal motivation describe one’s motives towards other individuals and groups, “L2 self-confidence concerns the relationship between the individual and the L2” (MCDN, p. 551). Like state communicative self-confidence, it is regarded as composed of both L2 anxiety and perceived L2 competence, though in a more stable, trait-like manner.

#### **Layer V: Affective-cognitive context**

Layer V represents the “affective-cognitive context,” referring to a series of enduring characteristics of the individual that encompass the “accumulated prior history and broad-based

attitudes and motives of an individual” (MCDN, p. 552). An attention to these motivational components form the core of the *socio-educational model* (Gardner, 1985) and other “social process models” such as the *social psychological model* (e.g., Lambert, 1973), the *social context model* (Clément, 1980), the *intergroup model* (Giles & Byrne, 1982), the *acculturation model* (e.g., Schumann, 1986). However, as Gardner (1985) himself notes, these models delineate the relationships between affective-cognitive factors and ultimate outcomes such as L2 acquisition and proficiency, and are less concerned with actual language use. As such, the L2 WTC model seeks to link these well-known constructs to the actual moment of L2 use. In particular, intergroup attitudes such as *integrativeness* (the desire to affiliate with members of the outgroup) and *fear of assimilation* (fear of losing one’s original cultural identity) are seen as dampening subsequent motivation for intercultural contact. Meanwhile, attitudes towards the L2 will impact the extent to which the individual engages with the L2 within the classroom, and forms an intrinsic motivation to learn and use the L2.

Following Hymes’ (1972) usage-based description of linguistic knowledge, *communicative competence* is the multi-faceted ability to engage in effective, context-appropriate L2 communication. Expanding upon earlier models of communicative competence (Canale & Swain, 1980; Canale, 1983), Celce-Murica et al. (1995) offer a five-part model of communicative competence: *linguistic competence*, or the ability to use a language’s syntax, lexicon, morphology, and phonology; *sociocultural competence*, or the ability to use linguistic knowledge appropriately given the context (register, tenor, and mode) of the interaction; *discourse competence*, or the ability to construct cohesive stretches of text; *strategic competence*, or the knowledge of strategies to maintain effective communication and repair breakdowns. The particularly significance of Celce-Murcia et al.’s model to the current discussion is the notable addition of *actional competence*, or the ability to convey and discern communicative intent through knowledge of the functions of speech acts.

Drawing on previous frameworks outlining components of an interaction, MCDN also put forth as a part of the affective-cognitive context the *social situation*, consisting of the following aspects: participants, setting, purpose, topic, and channel of communication. Participant social categories are considered to be particularly important, including age, gender, and social class, as well as various aspects of interpersonal relationships, including power-dependence balance, the level of intimacy and familiarity, and status differences. MCDN emphasize that familiarity with a situation (or another person) is particularly important in facilitating L2 self-confidence. They point out exposure to novel situations as a potential stumbling block for WTC, as these situations may lie outside of one's knowledge of how to cope with the situation, and thus will be more likely to provoke emotional arousal (see Lazarus & Folkman, 1984).

#### **Layer VI: Social and individual context**

Finally, the bottommost layer pertains to the “social and individual context,” and, along with the stable affective, cognitive and motivational variables outline above, was the focus of the social psychological period of L2 motivation research. They “set the stage for L2 communication, but are less directly involved in determining a learner’s WTC at a given time” (MCDN, p. 558). The “intergroup climate” incorporates the structural features of the society at large, as addressed by the *intergroup theory* (Giles, *et al.*, 1977; Giles & Taylor, 1982) and *acculturation theory* (Schumann, 1986). For instance, to capture an objective sense of a group’s sociostructural situation among other groups, Giles et al. (1977) introduce *ethnolinguistic vitality*, defined “that which makes a group likely to behave as a distinctive and active collective entity in intergroup situations” (p. 308), and composed of as a range of demographic, institutional, and social variables.<sup>29</sup>

---

<sup>29</sup> Ethnolinguistic vitality has been generally viewed as containing three interrelated, objectively-defined sociostructural variables: demographic variables (e.g., group size, immigration patterns), institutional support (i.e., the group’s representation within various social institutions), and social status (i.e., the group’s perceived position in relation to others). Vitality therefore focuses on the language *group* as the basic unit of analysis, rather than the individual.



Individual context is seen in terms of broad, stable personality traits of the individual that condition psychological antecedents to L2 use, such as intergroup attitudes and L2 self-confidence, favorably or unfavorably. As seen below (MacIntyre, 1994; Clément, *et al.*, 2003), researchers have generally looked at well-established personality factors, including the “Big Five” personality traits of openness to experience, conscientiousness, extroversion, agreeableness, and neuroticism (Goldberg, 1993). In all, the intergroup structural setting and personality are seen as distal influences, with their impact mediated by more immediate antecedents in the other stages.

### **3.2.2. Review of studies**

In this section, I conduct an extensive review of the psychological antecedents strand of L2 WTC research. This body of research examines the predictors of L2 WTC within various situated contexts in which L2 communication takes place. A majority of both theorization and empirical work on L2 WTC has occurred within the context of Canada, where English and French possess officially co-equal status. Despite regional differences and the overall demographic advantage of English, the co-existence of the two ethnolinguistic groups in some areas presents L2 learners with naturalistic L2 opportunities. Furthermore, governmental policies protecting the legal status of French as an official national language have led to enhanced opportunities for L2 use (as well as its potential usefulness), even in monolingual regions. The common focus of these studies rests on the interrelationships among relatively stable individual differences (i.e., Layers IV – VI), as well as individual attributes which moderate these relationships.

#### ***Attributes: Gender and Age***

MacIntyre and colleagues have conducted several investigations focusing specifically on how gender and age (measured as educational level) may impact L2 WTC and its antecedents – both overall, and in interaction with the educational program (Baker & MacIntyre, 2000; MacIntyre, *et al.*, 2002; Donovan & MacIntyre, 2005). In general, these studies posit a range of effects of gender and age on various language-related variables, among them L2 WTC.

The results are complex. While numerous significant main and interaction effects of both gender and age on WTC and L2 anxiety are found across these studies, they only partially conform to hypothesized differences between girls and boys, and across age groups. Taken together, these studies have found that age and gender often play significant roles in predicting L2 WTC, though not in a constant, predictable manner.

Across these studies, MacIntyre and colleagues assign fundamentally norm-based explanation to their findings regarding gender. For instance, MacIntyre et al. (2002) suggest that boys may be communicating in the L2 outside of the class, while girls may favor in-class interaction. However, MacIntyre and colleagues are unable to find any stable, generalized patterns that cut across contexts, suggesting the complexity of such normative processes.

Nonetheless, despite sporadic results, these norm-based interpretations open the door for a look into how the L2 as social practice is relationally maintained through interactions between learners, with personal characteristics (e.g., gender) impacting one's developmental trajectory. Social norms may eventually come to be internalized by the learners, impacting their dispositional WTC and other communication tendencies. Such a basic explanation of norm internalization features in the network study in Chapter 5.

### ***Classroom setting***

Given the stated educational focus of L2 WTC, a number of researchers have treated context by looking at L2 classroom/program. Particular attention has been paid to the L2 classroom as a social arena for L2 contact opportunities – oftentimes the learner's only regular source of L2 opportunities. The L2 classroom/program thus plays a crucial role in exposing the learner to the L2 input in a goal-directed manner (though these goals may not coincide with those of the learner).

Accordingly, a number of studies already mentioned above have looked at the impact of immersion versus nonimmersion programs on L2 WTC and use (e.g., Baker & MacIntyre, 2000;

MacIntyre, *et al.*, 2002; Donovan & MacIntyre, 2004). They generally make the anticipated hypotheses that the greater exposure to the L2 provided by immersion programs has beneficial effects on frequency of L2 communication, L2 WTC, L2 communication apprehension, and L2 self-perceived communication competence. The results are (unsurprisingly) supportive of the hypotheses. MacIntyre and associates generally find the expected correlations between participation in immersion programs and a number of communication variables, including L2 WTC, frequency of L2 use, and perceived L2 competence.

Opportunity is thus treated differentially by classroom group. Students in the same program-type are assumed to receive more-or-less equal opportunity to use the L2 by virtue of the program content. In turn, repeated opportunities are seen as impacting the development of the students and their typical L2 behavior. These studies thus importantly assume a recursive notion of L2 WTC; past opportunities to use the L2 give rise to current disposition towards using the L2. While seemingly obvious, this is important: it suggests that systematic differences in the opportunity to use the L2 may produce systematically different communicative tendencies. This is the central assertion of the network study in Chapter 5, although taken to the level of the individual, rather than the class.

### ***Personal contexts***

Two important L2 WTC studies have focused on the immediate set of available L2 opportunities as perceived by the L2 learner (MacIntyre & Charos, 1996; Clément, *et al.*, 2003). These studies thus share a key feature with the proposed network approach to investigations of L2 use and intention (including that in Chapter 5): a systematic treatment of opportunity at the level of the individual. Personal context is taken into account as a nested, ego-centric variable – in these studies, this is accomplished by means of a measure of the proportion of L2 to L1 contact at home and at work as reported by the participant (see Clément, 1986). Given the attention to individual-level context, I review these studies in some detail.

Looking at a conversation course in L2 French for adult Anglophone learners of L2 French in a bilingual Canadian city, MacIntyre and Charos (1996) examine how global personality traits are interrelated with affective variables (i.e., motivation, attitudes toward the learning situation, self-perceived communication competence, communication anxiety) within a hybrid model of L2 WTC and the socio-educational model (Gardner, 1985). As predicted by the L2 WTC model, the effect of context on L2 use is mediated by more immediate communication-related antecedents, such as language learning motivation and perceived L2 communicative competence. Thus, along with a number of global personality traits,<sup>30</sup> context is found to have a distal influence on WTC and L2 use.<sup>31</sup>

Unlike personality traits, however, personal context is *also* seen as a more immediate antecedent of L2 use as well, structuring not only psychological antecedents to L2 use, but also L2 use itself. In particular, MacIntyre and Charos' (1996) empirical path analysis indicates three direct, positive paths originating from personal context (L2 contact): a theoretical path to L2 WTC; a theoretical path to L2 communication, and a data-driven path to L2 confidence. The direct path to L2 WTC is particularly important, suggesting that those who are repeatedly presented with more opportunities to use the L2 are more willing to use it.

Clément et al. (2003) offer an important study which focuses on the impact of multiple levels of context on L2 WTC. Looking at Anglophone and Francophone university students, they test the L2 WTC model in conjunction with Clément's (1980) social context model, which highlights the impact of L2 contact and L2 self-confidence on L2 acquisition. Within this joint model, context is considered at the micro-level of the individual (through a personal contact index as seen above) and at the

---

<sup>30</sup> MacIntyre and Charos (1996) make use of the "Big Five" personality traits (Goldberg, 1993), namely, openness to experience, conscientiousness, extroversion, agreeableness, neuroticism (OCEAN). They substitute "intellect" for openness, "emotional stability" for neuroticism.

<sup>31</sup> Hashimoto (2002) conducted a replication study of MacIntyre and Charos (1996) involving a relatively small sample (n = 54) of Japanese university students studying in Hawai'i. While her model also exhibits a number of important differences with the L2 WTC model, she offers little explanation as to how context might produce these differences. Given the study's small sample size, the results may be questioned.

macro-social level of group vitality.<sup>32</sup> Using path analysis, Clément et al. (2003) find support for a theoretical model in which greater quantity and quality of contact with the L2 predict higher L2 confidence among both groups. In turn, L2 confidence impacts L2 communication in various ways, including an indirect effect as mediated by L2 WTC.

However, Clément et al. (2003) also find a number of contextual differences between Francophones (low vitality) and Anglophones (high vitality) groups which suggest the fundamental impact of the sociostructural environment on altering relationships among communication variables. They find that L2 confidence predicts L2 WTC less strongly among the Francophone minority than among Anglophone majority. They also find that quality of L2 contact is directly linked to L2 WTC among Francophones, but only indirectly linked among Anglophones (through L2 self-confidence). Clément et al. (2003) maintain that these results are indicative of a “postlinguistic stage” of contact among the Francophone minority in which perceived L2 confidence has developed to such a point that individual difference no longer impinge upon communication and identity.

The findings of MacIntyre and Charos (1996) and Clément et al. (2003) are important from a network perspective for several reasons. First, the measurement of each participant’s frequency and quality of L2 contact constitutes a nested, ego-centric representation of social context; context is not treated as a singular, uniform entity that blankets all participants in an equal fashion. As a result, *opportunity is treated systematically* individual by individual – not as a group-level characteristic, or as random error. Social structure is thus not treated as just a macro-scale entity (vitality); it is also a sociological factor even at the level of the individual (contact).

In turn, these systematic, individual-level differences are found to *directly* impact L2 WTC; the willingness to use the L2 is not completely independent of the opportunity to use it. Those individuals with greater opportunity to use their L2 use over a past amount of time are more willing

---

<sup>32</sup> Furthermore, intermediate contextual levels are recognized, with the researchers pointing out Francophone students’ multiple-minority status of being Francophone in both primarily Anglophone country (Canada), city (Ottawa), and university.

to use it in the present. Therefore, while one may distinguish between the momentary intention to use the L2 and a single opportunity to use the L2 (see MCDN), these findings suggest that *trait-like* L2 WTC may be directly related to the regular opportunities found in one's personal context.

Therefore, when looking at general communicative tendencies (i.e., regularities in behavior), it is essential to examine corresponding regularities in *opportunity* for that behavior. Such regularities in opportunity at the individual level may be delineated using various techniques. Conceptualizing and testing such regularities is the focus of the network study in Chapter 5.

### **3.2.3. Interim summary**

This individualistic view of intention proposed by Fishbein and Ajzen (1975; Ajzen, 2005), and emulated by the psychological antecedent strand of L2 WTC research, looks intently on the inner workings of the individual mind. The aim is to predict and explain actual behavior that is under the volitional control of the individual, as determined by his/her beliefs, desires, and intentions. A core assumption is that volitional control over action is incomplete to the extent that an action depends on others.

Accordingly, the psychological antecedent strand has focused on the interactions of various individual differences in influencing L2 use, which is assumed to be more-or-less under volitional control (at least in the research settings). Resulting from this view of L2 behavioral intention is a range of intriguing and important results regarding those variables that influence dispositional L2 WTC. Together, these studies have produced a clearer picture of how varying amounts of exposure to the L2 in various institutional and personal settings leads to various causative associations between L2 WTC, motivation, communication anxiety, perceived L2 competence, and other variables.

A general limitation of this swathe of studies, however, lies in the lack of emphasis placed on links between the participants themselves (despite the common sampling technique of testing

whole educational communities). Consequently, the ways in which learners use the L2 with each other go largely unaddressed. While attention is paid to the frequency and quality of L2 contact, no attention is paid to *why* individuals deemed that input to be high in “quality.” Little emphasis is placed on L2 input as personally meaningful and sought out by the actively engaged learner trying to pass a course, find a friend, or otherwise function effectively. Consequently, the way in which the knowing and using the L2 actually *benefits* the individual remains unclear. What the L2 learner achieves through use of the L2 must be assumed.

Finally, a further limitation is that L2 WTC and L2 use are largely assumed to be essentially stable over time. The studies reviewed above do this by asking participants to report their L2 WTC at the current time, as well as asking them to report the frequency of communication over some past timeframe. Subsequently, models treat (present) L2 WTC as causative of (past) frequency of communication. To accept this theorized direction of causality as valid, one must assume that L2 WTC is an essentially stable construct (at least in the contexts investigated), with current L2 WTC reliably predicting one’s past WTC that would have led to the reported frequency of L2 use. This could feasibly be the case in some of the multilingual settings mentioned above, in which L2 learners have possibly reached some sort of equilibrium point where L2 WTC and L2 use are in a more-or-less stable relationship. However, this would represent an exception to the dynamic, fluctuating character of L2 WTC highlighted by MCDN.

### **3.3. L2 WTC as participation: The social co-construction strand**

In this section, I turn attention to L2 WTC as the readiness to enter into co-constructed discourse with a particular person at a particular time. Such a view of L2 WTC changes one’s approach to intentionality. Rather than focusing purely on the various cognitive, affective, and motivational processes that predispose the individual towards L2 communication, attention shifts in part towards that at which L2 communication is being directed. This shift towards the social and cultural “discourse” in which learners are participating raises important issues regarding how this

discourse is conceptualized, and the role of learners as intentional agents in (re-)constructing it. Ultimately, such a turn helps in formulating a richer account of how individuals help to shape each other's L2 WTC.

In the current section, I look at the human capacity for shared intentionality as key to explaining the co- construction of L2 WTC and of the shared meaning behind L2 use. I review studies of L2 WTC that more directly account for the relationship between L2 WTC and joint, meaningful activity. The assumption is that whenever learners are actively engaged with the L2, they are enter into a co-constructed social reality that supports this use. As seen later in Chapter 5, a social constructivist take on shared intentionality permits us to better conceptualize the differentiation in group norms that is assumed to take place between various social clusters within a community of L2 learners.

### **3.3.1. Social interactionism and shared intentionality**

An important aspect of the “educational shift” in L2 motivation research out of which the L2 WTC model developed was an acknowledgement of the role of instructors in instilling and sustaining motivation in learners. The more general implication was an increasing acceptance of individuals – learners as well as teachers – as active sense-makers of the input they receive within instructional settings. Such a perspective is inherent within a social interactionist approach to education, as most prominently exemplified within the works of Lev Vygotsky. Williams and Burden (1997) explain the central tenet of this approach:

For social interactionists, children are born into a social world, and learning occurs through interaction with other people. From the time we are born we interact with others in our day-to-day lives, and through these interactions we make our own sense of the world. (p. 39)

Social interactionists therefore consider learning to be an active, relational endeavor – something that occurs *between* individuals before it happens *within* an individual. While personal meanings



may vary considerably due to complex differences in interactions from person to person, these meanings do not occur within a social vacuum; individuals help one another make sense of the world.

The process of sharing meaning is generally known as mediation. In instances of mediation, one person “transcend[s] the immediate needs or concerns of the recipient of the mediation by venturing beyond the here and now” (Feuerstein, 1980, p. 20).<sup>33</sup> For instance, a parent might act as a mediator by scaffolding a child’s account of what she did at school earlier that day with probing questions, thereby presenting the child with a goal of successfully recounting the day’s event. Similarly, in the language classroom, a mediator (a teacher or a classmate) might model the appropriate use of a given language form in order to accomplish a learning task, such as using polite forms of language in an imagined social setting, or using kinship terms to portray oneself as a member of a family. In either case, the mediator helps construct a view of the world that the learner might not accomplish on his/her own, thereby permitting the learner to accomplish more than he/she would have otherwise been capable.<sup>34</sup>

Language, of course, plays a fundamental role in this mediation process. As Lantolf and Thorne (2007) note, language allows humans to transcend the immediate environment:

Language imbues humans with the capacity to free themselves from the circumstances of their immediate environment and enables us to talk and think about entities and events that are displaced in both time and space, including those events and entities that do not yet exist in the real world. (pp. 201-2)

---

<sup>33</sup> Feuerstein (1980) refers to these inherently intentional and transcendent interactions as *mediated learning experiences*.

<sup>34</sup> This is referred to by Vygotsky’s well-known concept of the Zone of Proximal Development (ZPD) (see Lantolf & Thorne, 2007).

Therefore, language permits individuals to share in representations of entities and events other than themselves; that is, it permits intentionality to be *shared* among individuals. It is composed of intersubjective devices that enable individuals to jointly represent and act upon a vast array of objects, ideas, concepts, events, and persons not necessarily present in the immediate surroundings.<sup>35</sup> This capacity allows individuals to coordinate their activity towards some goal (Tomasello & Rakoczy, 2003; Tomasello, *et al.*, 2005). Through the use of language, humans may arrive at an agreement on a future state of affairs, and an action plan on how to get there.

According to this viewpoint, therefore, language learning is not the process of acquiring a singular, fixed entity to be replicated according to some native-like formal ideal. Rather, one is learning to manipulate and engage in a larger human system of “semiotic activity” that permits one to share intentions with others in order to achieve certain ends, such as representing, planning, coordinating, sending and receiving important information, and communicating one’s rights and obligations (van Lier, 2000; see also Ellis, 2006). With increased competence, the learner comes into closer contact with social meanings and identities associated with the new language.

Precisely what individuals are psychologically ready to “enter into” when high in L2 WTC thus begins to take shape. With increased L2 WTC, the L2 learner/user is motivated and sufficiently confident to share thoughts, emotions, and experiences with others using the L2. The L2 is a linguistic resource that permits the learner/user to establish or maintain a meaningful social identity.<sup>36</sup> ‘Discourse’ may therefore be thought of as the co-constructed social meanings residing within a community, including stereotypes, various social roles, social norms, useful ways of doing things, and so on. The learner/user must utilize these in order to get things done.

---

<sup>35</sup> These aspects, referred to as *affordances*, may be linked to the notion of opportunity that is the focus of this thesis, and will be covered in detail beginning in Chapter 3.

<sup>36</sup> This echoes Eckert’s (2000) discussion of the use of linguistic variants among American high-school students to enact valued social identities.

However, culture is not created anew in every interaction, but is transmitted across communities from one person to the next, and is re-shaped in the process (D'Andrade, 1981). The challenge, therefore, lies in describing the pattern of social interactions by which individuals mediate for one another in collaborative attempts at sense-making. Shared meaning is likely to be socially bound, confined to the frequent interactions of cohesive social clusters. Consequently, it is necessary to look beyond the individual's immediate personal network of regular social interactions, and examine his/her location within wider social structures. This issue is addressed empirically in Chapter 5.

### **3.3.2. Situational L2 WTC**

An emphasis on “entering into discourse” raises a crucial empirical gap within the body of dispositional L2 WTC studies reviewed above; these studies are unable to capture the dynamic, momentary qualities of WTC as it unfolds within a given encounter. Accordingly, MacIntyre (2007) calls for a re-emphasis on L2 WTC as a situated phenomenon – a momentary psychological readiness to engage and continue engaging in an L2 interaction. Of importance should be the moment-to-moment, potentially volatile rise and fall of this readiness in accordance with changes in the situation.

WTC... represents the final psychological step in preparation for L2 communication. In effect, the time has come to take action—Am I willing to initiate communication, or am I choosing to remain silent? This is a moment that we must better understand. (p. 568)

Predating MacIntyre's argument are several process models of L2 motivation that approximate his call (Williams & Burden, 1997; Dörnyei & Ottó, 1998; Dörnyei, 2000). Although not specifically termed models of L2 WTC, these frameworks nonetheless pertain to the general phenomenon of interest: the various stages of initiating and sustaining effort towards meeting a meaningful goal in

the language classroom, and in instances of L2 use. Together, they address a key issue raised throughout this thesis: the agency of the L2 learner/user in the face of an opportunity.

Williams and Burden (1997) put forth a social constructivist framework of motivation which presupposes that each L2 learner is motivated potentially differently. At the same time, however, the individual is influenced by various social and contextual factors that affect how that motivation is ultimately expressed. They conceptualize motivation as “a state of cognitive and motivational arousal which leads to a conscious decision to act, and which gives rise to a period of sustained intellectual and/or physical effort in order to attain a previously set goal” (p. 120). Accordingly, they offer a three-part model in which motivation is composed of formulating a reason for action, deciding to initiate action, and persisting in one’s pursuit of the goal. This social constructivist model of language motivation therefore fits extraordinarily well with the notion of L2 WTC not as a fixed, trait-like variable, but as a dynamic, fluctuating interaction of personal desires, momentary levels of confidence, and situational parameters.

In a highly similar fashion, Dörnyei and Ottó (1998; Dörnyei, 2000) maintain that the view of motivation as a constant may be inappropriate in two situations: in examining complex actions that involve planning, goal setting, and execution, and; in investigating long-term activities that require prolonged effort and constant reappraisal in the face of unfolding influences. They therefore incorporate a temporal dimension into a process model of motivation in order to describe which motivational processes come into play at different times:

[M]otivation can be defined as the dynamically changing cumulative arousal in a person that initiates, directs, coordinates, amplifies, terminates, and evaluates the cognitive and motor processes whereby initial wishes and desires are selected, prioritised, operationalised, and (successfully or unsuccessfully) acted out. (Dörnyei, 2000, p. 524)

Context, therefore, can only be understood in terms of how it interacts in fluctuation with motivation, personal capacities, and emotional states over different phases of a fundamentally discrete interaction.

Particularly relevant to the current thesis is Dörnyei and Ottó's (1998) explicit attention to the notion of opportunity. An opportunity for interaction prompts the individual to set a goal in accordance with his/her desires, hopes, and values. Opportunity therefore constitutes a key component of their process model from the outset: "[Opportunity] is included because on occasions the starting point of the motivated behavioural process is not the individual's fantasy land but rather an emerging opportunity" (1998, pp. 47-49). Subsequently, an intention to behave in a certain way is formed. At this stage, the individual formulates an action plan composed of strategies aimed at accomplishing the goal and an associated timeframe. As part of this, the individual must either comply with the demands of an authority, or exercise commitment towards a decided course of action in the face of alternatives. Once the conditions for action are met (e.g., time frame) and the individual possesses the required means to accomplish the goal, the individual "crosses the Rubicon" and initiates action.

It is the crossing metaphor which captures the attention of MacIntyre (2007) in his reemphasis of L2 WTC as a volitional process. Consequently, he issues a call for methodologies that investigate the complexity of intersecting motivation (approach) and anxiety (avoidance) seen within a given instance of L2 use.<sup>37</sup> Indeed, it is this basic focus on L2 use as it unfolds that has motivated a number of studies of situational L2 WTC. As reviewed in the following section, examining the moment of action, and persistence in that action, requires one to look at the basic personally held motives pushing the individual further in the face of a (challenging) L2 interaction or task.

---

<sup>37</sup> A call which he himself responds to (see MacIntyre & Legatto, 2010; see below).

### 3.3.3. Review of studies

In this section, I review the studies associated with the social co-construction strand of L2 WTC research. First, I review studies of dispositional L2 WTC that focus on the shared social meanings attached that learners attach to use of the L2. These studies are especially important in offering structural insights on dispositional L2 WTC because, in looking at social groups of learners, these studies venture beyond the micro-level, face-to-face interactions and look at how communities of learners co-construct and maintain these meanings. These studies are thus especially relevant to the network study in Chapter 5. I therefore review these studies in particular detail.

Second, I look at studies of situational L2 WTC, which fixate on the emergence of L2 WTC between individuals engaged in an interaction. As such, these studies take a close look at the sustained effort involved in carrying out L2 interactions. Finally, I touch on the next wave of L2 motivation (and L2 WTC) research – a dynamic systems approach, which expands upon the notion of situational L2 WTC and offers new ways of conceptualizing and investigating the emergence of L2 WTC.

#### ***Studies of dispositional L2 WTC***

Yashima and her colleagues (Yashima, 2002; Yashima, *et al.*, 2004; Yashima & Zenuk-Nishide, 2008) have taken on an increasingly relational approach in investigating L2 WTC across different learning settings. Looking primarily at Japanese learners of English in both foreign- and second-language contexts, they introduce and argue for the importance of *international posture* – an attitudinal tendency encompassing “interest in foreign or international affairs, willingness to go overseas to stay or work, readiness to interact with intercultural partners, and, one hopes, openness or a non-ethnocentric attitude toward different cultures, among others” (Yashima, 2002; 57) and incorporates both instrumental and integrative aspects. The abstract notion of a generalized international community as the target language group is meant as a contemporary alternative to

Gardner's (1985) notion of integrativeness (Yashima & Zenuk-Nishide, 2008). Rather than being based on a desire to learn a language in order to be connected to a specific cultural group, it was conceived of as attitudes underlying a possible motivation to communicate across one's own cultural boundaries in a more general sense, thus fostering a sense of connectedness with an international "imagined community."

In subsequent articles, Yashima and her colleagues have begun to articulate this explicitly relational standpoint, adopting the notion of communities of practice (Lave & Wenger, 1991) and its application to L2 learning (see also Norton, 2000). At the heart of this perspective is the interdependence of social actors; they argue that a group (community) of L2 learners comes together around a mutual interest – in this case, an interest in international affairs (i.e., international posture). Through participation in this group, students continue their interest and move towards a desired social identity.<sup>38</sup> Full participation requires not only competence in the language which delineates the group (L2 English), but also active *use* of that language. With such an emphasis on actual usage, WTC comes to the fore as a pre-eminent factor – those who are both able *and willing* to use English reinforce their membership in an informal group. Resembling ethnolinguistic vitality on a smaller scale, international posture establishes a shared social reality within this group, with the members relying on one another to perpetuate a rather abstract vision of L2 usage. Thus attitudinal and behavioral variables – of which international posture and WTC are just two examples – can be explained in reference to the interdependence that Lewin (1948) places at the core of social life.

For instance, in a longitudinal study, Yashima and Zenuk-Nishide (2008) examine the impact of the L2 learning context on L2 proficiency, L2 WTC, frequency of L2 communication, and international posture. The researchers focus on two cohorts of Japanese ESL/EFL students at the same high-school – each aligned with a different learning track – a content-based global studies

---

<sup>38</sup> A strong conceptual link can thus be drawn to Dörnyei's (2005; 2009b) notion of a desired future self within his L2-self system (see below).

option, or a more traditional grammar-translation option focused on university entrance requirements (with a small number of students from each cohort taking part in extended stays abroad in one of a number of English-speaking countries). As hypothesized, the study-abroad students displayed the expected gains in the dependent variables. However, unexpectedly, the researchers did not find a clear pattern of differences between the two at-home sub-cohorts – one a content-based program with a global studies emphasis, and the other a more traditional EFL program with a grammar/translation focus.

To investigate possible group differences further, Yashima and Zenuk-Nishide (2008) employ analytical techniques similar to those found in network studies. They make use of hierarchical cluster analysis to separate participants into subgroups based on similar sets of scores on international posture, WTC, TOEFL scores, and other related attitudinal and behavioral variables. Hierarchical clustering differs from other techniques used by network analysis in that it identifies clusters of similarly-responding participants, rather than those who are necessarily directly tied to one another. However, the respective techniques are similar in one major respect: they both aim to delineate *informal* subgroups not marked by any official membership distinction, such as program enrollment.

The subsequent comparisons between clusters largely supported what analyses of the formal division between course tracks did not: namely, that respective learner groups progressed differently in terms of growth in L2 proficiency and international posture. However, instead of formally defined program participants, it was *informal* clusters of learners that bore significant differences in development. With the fastest-developing group of at-home students comprised mostly – though not exclusively – of students from the content-based option, Yashima and Zenuk-Nishide (2008) mostly confirm their initial hypothesis that participation within an imagined community facilitates L2 growth. In this particular site, however, community membership appears to cut across class boundaries, raising the strong possibility that informal relationships (i.e., friendships)



among the students serve as paths of influence that shape the individual's development in L2 attitudes, use, and proficiency.

Following on from Yashima's studies, Peng and Woodrow (2010) investigate the influence of the classroom environment on trait-like L2 WTC among Chinese EFL students. Their perspective is ecological, explicitly basing their conceptualization of the socially-constructed classroom. In particular, they view the classroom environment as composed of teacher support, student cohesiveness, and task orientation. In an empirical SEM model similar to those of Yashima (2002; Yashima, *et al.*, 2004), they find direct effects of these classroom factors on WTC, communicative confidence, and learner beliefs. These results support the notion that supportive classroom relationships and clearly-defined, interesting learning tasks help to foster dispositional L2 WTC.

Examining the role of social support on the L2 WTC of immersion students of French in a predominantly Anglophone area of Canada, MacIntyre et al. (2001) investigate the impact of individuals' nested interpersonal environments and social exchange on L2 WTC. In particular, they find that students who report that their friends want them to use French have higher levels of WTC *outside the classroom*. Notably, however, they also found that similar support from siblings led to increased WTC *regardless of location* – inside and outside the classroom – albeit to a lesser degree than friend support.

In actuality, MCDN's notion of "social support" is quite a specific one. In a departure from its usual sense, social support is not treated as a wide-ranging, multi-dimensional concept encompassing many forms of sociation and comforting (socio-emotional support), as well as more tangible forms of assistance (instrumental support) (see Malecki & Demaray, 2003 for review). Rather, they are looking at one quite specific aspect of social support: *appraisal support*. This form of social support is the information that one receives from others that help one to assess one's ability and the appropriateness of one's behavior. Appraisal support can thus be seen as the information flowing between individuals that allows them to influence one another – in this case in terms of their

L2 behavior. This form of support is crucial in the development of intrinsic motivation, which arises out of informational, and not controlling, input from others (Deci & Ryan, 1985; 2000).

### **Structural insights**

The studies by Yashima and colleagues (Yashima, 2002; Yashima, *et al.*, 2004; Yashima & Zenuk-Nishide, 2008) as well as by MacIntyre *et al.* (2001) offer a number of particularly important structural insights regarding cohesive subgroups and role equivalence<sup>39</sup> that directly inform the research hypotheses made in the network study in Chapter 5. By emphasizing the impact of informal learner communities on communication tendencies, Yashima and Zenuk-Nishide (2008) open the door for positing the role of informal community structure in influencing L2 WTC among community members. The first major insight is that social meaning – in this case an interest in international affairs – may often require more than just two individuals to maintain. Presumably, the formation of a meaningful social group which provides the impetus for L2 use requires a flurry of activity occurring simultaneously among various members, creating a general ‘buzz’ among the group. That is, it is difficult to see how two interlocutors acting on their own could successfully create for one another an imagined reality of international affairs, full of model UN meetings, group discussions, and collective action for social change. As a result, looking merely at a single interaction may not account for the greater phenomenon of the group’s collective intentionality in creating an imagined community of meaningful L2 use.

Furthermore, if indeed the clusters within Yashima and Zenuk-Nishide’s (2008) study represent actual (cohesive) communities, they should possess their own internal status hierarchies and group roles. In turn, these structural features should fundamentally shape the contours of communication (see Levine & Moreland, 1990; Ehrman & Dörnyei, 1998). L2 WTC may therefore simply be a reflection of the individual’s speaking rights within the community. While communities may differ in the overall degree to which they endorse the L2 as the accepted means of

---

<sup>39</sup> See sections 2.3.1 and 2.3.2 for overview of these concepts.

communication, not everyone can speak all the time. Instead, speaking rights must be allocated in order to coordinate group activity, with some individuals having to take a backseat role within the community, at least at times. Consequently, changes in one's role and positioning within respect to the community may impact one's overall willingness to speak up. L2 WTC may therefore change in reference to social structure rather than growing in a linear fashion as a function of time or experience.<sup>40</sup>

The significance of MacIntyre et al.'s (2001) findings for a network approach to L2 WTC is twofold. First, the focused treatment of social support allows for more precise consideration of what specifically is important to the learner – in this case, approval of L2 use from important figures in his/her life. In prior and subsequent studies (e.g., Clément, 1986; MacIntyre & Charos, 1996; Clément, *et al.*, 2003), the exchange content of L2 interactions goes almost completely unconsidered, defining L2 contact in objectivist, interactional terms (e.g., L2 contact at home versus those at work). MacIntyre et al. (2001) thus diverge from other L2 WTC studies in that they consider the personal, subjectively-held relevance of L2 interaction to the learner's needs. As seen in Chapter 4, I expand on the issue of affordances for L2 use, and thus address the subjective processes behind appraising L2 contact as opportunity, threat, or challenge. Furthermore, as seen in Chapter 5, I investigate a core discussion network in which learners talk about 'important matters,' thereby relying on a similar notion of *personally meaningful* interaction.

Second, MacIntyre et al.'s (2001) study addresses a specific, central, testable issue within network studies: the extent to which L2 WTC emerges in face-to-face interactions (cohesion), versus the extent to which L2 WTC is modeled for the learner (role equivalence). The result that approval of L2 use by friends bolstered L2 WTC outside the class, while approval from a favorite sibling bolstered L2 WTC regardless of situation, is suggestive of two network processes potentially at work. The first

---

<sup>40</sup> This is supported by Yashima and Zenuk-Nishide's (2008) finding that L2 WTC differed between clusters, but not over time.

is social influence through cohesive ties. The amplification of WTC outside the classroom resulting from friend support suggests the emergence of particularly high L2 WTC among cohesive network subgroups (i.e., cliques of friends). However, within their discussion of these results, MacIntyre et al. suggest that this heightened WTC likely emerges primarily within the confines of the friend group. They explain these results in light of earlier findings (MacIntyre, Gouthro, & Clément, 1997; cited in MacIntyre *et al.*, 2001) in which young learners of L2 French were most likely to use the L2 as a secret code, or as a way to annoy monolinguals. Therefore, cohesive subgroups might be crucial in encouraging (or dampening) the use of the L2 as a form of personally meaningful social practice within the group activities, but does not necessarily come into play in other situations.

Meanwhile, MacIntyre et al.'s (2001) finding of sibling approval bolstering L2 WTC inside *and* outside the classroom suggests the influence of role equivalent individuals. As mentioned in the previous chapter, individuals are role equivalent to the degree that they share similar patterns of relations. Siblings are prime examples, possessing the same relationships with the same people, such as parents and other relatives, and often non-relatives, such as teachers and neighbors.<sup>41</sup> By virtue of the similar opportunities and obligations inherent in their ties, individuals look to role equivalent alters to get a clearer idea of the relative costs and rewards of adopting a given behavior (Burt, 1987). They thus provide ego with specific normative reference points for attitudes and behaviors. Consequently, role equivalent individuals might serve as crucial behavioral models for what are the acceptable/desirable ways of using the L2 in a variety of situations, at home, at school, with friends, and so forth. Thus, whereas cohesive ties might impact the dynamic emergence of L2 WTC within specific situations, structurally equivalent alters influence WTC more widely, shaping trait-like WTC across situations. This issue of the relative influence of role equivalence versus cohesive subgroups is tested directly in Chapter 5.

---

<sup>41</sup> Borgatti and Everett (1992a) even go so far as to use siblings to illustrate the concept of structural equivalence.

### ***Studies of situated L2 WTC***

Just as the studies of dispositional L2 WTC discussed above center on participation in some community of social meaning (i.e., social practice among friend groups, an interest in international affairs), studies of situated L2 WTC center around one's participation in the enactment of that meaning within particular encounters. In the studies reviewed below, individuals vary in the readiness to enter into various interactions and tasks with different personal significance, including research tasks (MacIntyre, *et al.*, 1999; Dörnyei & Kormos, 2000), structured and unstructured intercultural exchange (MacDonald, *et al.*, 2003; Kang, 2005), and classroom activities (Cao & Philp, 2006; Cao, 2009).

An important study of situated *L1* WTC that links state and trait was conducted by MacIntyre *et al.* (1999). The researchers first looked at various ID variables (personality traits, communication apprehension, self-perceived competence, self-esteem, etc.) as antecedents to trait-like WTC. In a structural equation model, they find broad support for the role of these stable entities on dispositional WTC, echoing the results of other WTC studies (e.g. MacIntyre, 1994; MacIntyre & Charos, 1996; Clément *et al.*, 2003). However, in a subsequent phase of the study, the researchers presented participants with an opportunity to communicate in the form of a solicitation to participate in a lab experiment. They find that those high in trait-like WTC were more willing to both volunteer for experimental tasks, and to complete them. The findings support the notion of trait-like WTC as the latent tendency to initiate communication, given the opportunity. When given the opportunity, this tendency is generally activated.

Dörnyei and Kormos (2000) find that individuals who were less inclined to participate in a contrived L2 learning task could nonetheless be inspired by an enthusiastic partner to contribute more readily to the activity. Among participants with negative attitudes towards the experimental L2 task, the number of turns produced was positively related to being paired with an individual with positive attitudes towards the task. This study is notable for two reasons. First, Dörnyei and Kormos'

(2000) directly investigate social status by means of a measure approximating point centrality – a simple yet important measure of popularity. As such, they offer a specific, testable conceptualization of status not found in any other L2 WTC study, yet which closely resembles measures found within network studies. Second, Dörnyei (2002) later explains this finding in terms of “co-constructed” task motivation. Task motivation (and the willingness to communicate within that task) can emerge as an aspect of the social tie between interacting individuals.

MacDonald et al. (2003) reports on personal accounts given by Anglophone and Francophone university students in Canada regarding social situations in which they felt most and least willing to use the L2. Among Anglophones, several general themes emerged. First, participants were most willing to speak the L2 in other-initiated interactions, especially in order to request assistance. Conversely, Anglophones often reported to be unwilling when it was left up to them to initiate interaction. Second, Anglophones were also willing to speak when they were confident that errors would go uncorrected, usually when speaking with friends and family. Meanwhile, situations in which the speaker lacked confidence, or in which the other was a stranger or another Anglophone, led to low situational WTC. Francophones, by contrast, reported using the L2 for affiliative purposes among peer groups that included non-Francophone friends. Similarly, Francophones reported politeness/respectfulness to be a significant impetus, either in responding to requests, or in order not to exclude from a classroom discussion.

Kang (2005) draws upon the idea of co-constructed motivation within her qualitative investigation of conversations between international students and their host national counterparts. Following three Korean exchange students participating in a conversation program at a US university, she finds that WTC is dynamic variable that emerges from situational variables, some of which are stable, others of which fluctuate quickly. In particular, she identifies three primary psychological antecedents for WTC: feelings of security, excitement, and responsibility. These three sets of feelings produce WTC in interaction with various situational factors, such as relationship(s)

with interlocutor(s), the topic of conversation, and the nature of the conversation as one-on-one or small group.

Cao and Philp (2006) conduct a similar qualitative investigation of situational and trait-like L2 WTC within small groups of international ESL students. They find similar results, reporting that in addition to self-confidence, familiarity with interlocutors, and cultural background, situational factors such as group size, participation by the interlocutor, and the medium of communication impacted one's own situational WTC. They point out that observed WTC is often discrepant with self-reports of trait-like WTC. By way of explanation, they draw on MacIntyre et al.'s (1999) aforementioned observation that trait-like WTC likely influences initial entry into a situation. However, once initiated, various unfolding situational factors play a significant role in the actual observed levels of L2 communication.

Taking an ecological perspective, Cao (2009) investigates L2 WTC as a situated, dynamic phenomenon that emerges within the classroom interactions of English-for-academic-purposes (EAP) students of various backgrounds studying in New Zealand. She emphasizes the importance of contextual factors on impinging or fostering WTC, maintaining that "individuals communicate differently with different interlocutors when discussing different topics in different situations" (p. 201). Replicating previous findings (Kang, 2005; Cao & Philp, 2006), she finds a number of contextual factors impacting situation WTC, including familiarity with the topic of conversation, the perceived competence of the interlocutor, and state L2 self-confidence.

However, Cao (2009) also places particular emphasis on situational WTC (or lack thereof) as an emergent phenomenon of the allocation of opportunities to participate. In instances where opportunities to speak were not distributed equally due to a particularly garrulous classmate grabbing every opportunity, individuals reported low situational WTC. Conversely, in situations where no one was willing to seize an opportunity, students reported WTC arising out of a feeling of

responsibility to “fill the gap” in the interaction. Cao’s study therefore suggests situational L2 WTC to be sensitive to the operation of various group processes, including group norms regarding fairness.

### **Relational insights**

Given their common focus on particular instances of L2 use, studies of situated L2 WTC provide a number of insights regarding the link between L2 WTC and the development of social relationships. Such insights are important, given how relationships are generally cast as the primary opportunities for L2 use (e.g., MCDN). In particular, these studies generally find that a number of cognitive, affective, motivational factors operating within relationships may moderate the degree to which the individual is willing to use the L2 with a specific person.

Kang (2005) and Cao and Philp (2006) focus on the parallel between L2 WTC, and the cognitive and affective dimensions of the relationships. Familiarity with one’s interlocutor is reported as one of the central factors impacting one’s WTC. Additionally, the “attractiveness” of the interlocutor<sup>42</sup> elicited greater interest in speaking. Furthermore, as expected, this cognitive largely coincides with the affective. Kang notes that the native interlocutor’s familiarity with the international student and his/her level of English proficiency engendered feelings of trust connected to the belief that language mistakes would be greeted with patience and without loss of face. Cao and Philp similarly remark that participants often cited familiarity with one’s interlocutor an important factor in whether or not they had interest in speaking, with that interest growing as acquaintances grew closer and became friends.<sup>43</sup>

---

<sup>42</sup> “Attractiveness” is not explicitly defined by Kang (2005), except for a type of linguistic attractiveness based around participants’ expressed preference for non-Asian-American interlocutors over Asian-American ones, borne out of a belief that the former group’s English was “better.” However, Kang also seems to be referring to general physical and/or social attractiveness.

<sup>43</sup> These findings support the central theorem advanced within a number of communication theories that optimal levels of uncertainty and emotional arousal regarding a potential interaction with an individual or group will facilitate the actual course of communication (Gudykunst, 2005a; 2005b).



As in the network conceptualization of tie strength, however, the cognitive (i.e., knowledge of one's interlocutor) and the affective (i.e., feelings of security and attraction), are not the only dimensions. Acknowledged within both studies is the role of *time*. Kang (2005) implicitly incorporates a temporal aspect in reporting that familiarity between interlocutors as building up over the course of repeated interactions. Cao and Philp (2006) make a similar observation in describing the development of familiarity and closeness over the course of several months. Thus, cognition and affect both appear to be linked to the temporal aspect of tie strength mentioned by Granovetter (1973) and others, with both familiarity and feelings of safety growing as time passes. The relationship between time and affect, however, might not be linear, as evidenced by Kang's description of some participants' initial excitement at the prospect of speaking to attractive individuals for the first time.

Lastly, participants in Kang's (2005) study reported viewing these relationships as sites of personally meaningful social exchange. Interactions with host nationals were appraised by participants as sources of important information regarding the host society, and as valuable opportunities to improve their English. The expected value that participants attached to such interactions impacted their willingness to enter into the conversation. Through these interactions, the participants saw themselves as improving upon their English skills and gaining important information pertaining to everyday life in their new environment, and thus possibly improving daily social functioning.

What emerges from studies of situational L2 WTC in general is how cognitive, affective, temporal and contextual factors do not just co-exist, but interact and mutually reinforce one another to produce one's willingness to interact in the L2. Notably, the interaction of many of these variables may be seen as occurring within the social tie, encapsulating how familiar individuals are with one another (cognition), how they feel about one another (affect), and how they work together to satisfy situational demands (contextual). In the end, this relational enactment is personally

meaningful in some way; the L2 is used to establish and maintain a stronger relationship, and/or to derive some benefit from it. Once again, the instance of L2 use is not “the end of the story” but plays a part in an ongoing cycle between L2 use and achievement of personally-held goals.

### ***A dynamic systems approach***

Recently, the field of SLA has begun to embrace the dynamic systems approach. Following the view of language as a complex adaptive system (de Bot, *et al.*, 2007; Larsen-Freeman, 1997; 2007b; Dörnyei, 2009a). MacIntyre and Legatto (2010) support investigating L2 WTC from a dynamic systems perspective. In accordance with methodological cautions that accompany this perspective (see Dörnyei, 2009a), they introduce an idiodynamic methodological approach. By means of a quasi-experimental design, their proposed methodology tracks a participant’s observed willingness to communicate, as applied to the sequential demands of a (pre-determined) interaction. In a series of retrospective activities involving a tape recording of the interaction, the participant rates the momentary rise and fall of his/her WTC, and offers commentary regarding recalled thoughts and feelings about the observed changes in WTC. Altogether, this methodology is a fine-tuned way of investigating dynamic L2 WTC. They permit observation of phenomenological fluctuations as the individual employs L2 cognitive resources in the mapping to L2 forms (e.g., L2 lexicogrammar, L2 pragmatic scripts) to functions needed to fulfill the requirements of the L2 task.

Just how radical of a shift in paradigms a dynamic systems approach to WTC will remain to be seen; it will likely be considerable, especially from a methodological standpoint. However, what is certain is that it will continue a trajectory already seen within the L2 WTC literature, focusing in on how personally-important motivations and various processes impact the course of L2 use at different points throughout an interaction.

### 3.4. Culture, networks, and L2 WTC

One contextual aspect still left to review is culture. McCroskey and Richmond (1990a; 1990b) claim that a careful consideration of culture is an essential component of any study examining WTC and communication-related phenomena. They argue that “communication norms and competencies are culture-bound” (1990b: 74). Getting to the root of what “culture-bound” refers to is in need of expansion if one is to understand the potentially fruitful intersection of networks, agency, and L2 use.

However, despite the stated importance of considering the impact of culture on L2 WTC, only a handful of researchers have taken on such a focus. Wen and Clément (2003) address the applicability of the L2 WTC model within the L2 classroom in Chinese cultures. They argue for the central role that traditional cultural values play in shaping how the learner perceives and learns within modern-day classroom settings in China. Accordingly, they adapt the model so as to reflect Confucian and Taoist values as a mediating layer between the situated antecedents (state self-confidence and desire to communicate) and L2 use within the Chinese EFL classroom. Values such as face-saving, other-directedness, and a passivity and deference towards the teacher serve as the basis of classroom norms that modify the emergence of L2 WTC, most often suppressing it. In terms of the process model (Dörnyei & Ottó, 1998), it is as though individuals go through a speculative, imagined postactional stage *before* they “cross the Rubicon,” with these traditional cultural values setting one’s expectations regarding what the consequences of a given action will be.

In addition to the impact of cultural values, Wen and Clément (2003) posit the particular importance of group cohesiveness and teacher support as mediating factors between the desire to communicate (Layer III) and (often suppressed) L2 WTC within the classroom. These aspects of local social structure are seen as playing a much more immediate, direct role in influencing L2 WTC than it does in the original model. They also intervene at a much more proximate point than the “social situation” (Layer V). Wen and Clément see the influence of these structural factors as creating a

positive learning 'atmosphere' would presumably *promote* the number of opportunities, as ties among classmates form and grow stronger.

In an empirical qualitative study, Peng (2007) investigates the interaction of individual, classroom and cultural factors in producing and dampening L2 WTC among Chinese EFL students. She finds eight themes related to the individual context (communicative competence, language anxiety, risk-taking, and learners' beliefs) and the social context (classroom climate, group cohesiveness, teacher support, and classroom organization). Among the more notable findings, Peng suggests an important role of cultural factors such as face ('*lian*') and moderation ('*zhongyong*') as setting up L2 communication as a particularly risky endeavor within the FL classroom in China; potentially making a mistake may lead to a loss of face, while speaking up within a silent class may at times seem brash and disrespectful of one's peers.

Overall, the sociocultural context of the classroom – in *any* cultural context – should therefore be theorized not merely a distal conditioning influence, but an immediate social arena that provides opportunities, challenges, and threats that students must learn to manage – preferably using the L2. Furthermore, cultural values are the ingrained template by which individuals (to various degrees) appraise potential interactions as either beneficial or threatening. Wen and Clément (2003) and Peng (2007) respectively indicate that Chinese cultural values sensitize the individual towards the latter (appraisals of risk). This could be because overt demonstrations of competence are generally interpreted within the Chinese classroom as coming at the expense of others' competence, and thus face-threatening. Culture serves as the basic evaluative frame. While different cultures may lead individuals to appraise potential interactions differently, individuals from similar backgrounds are inclined to interpret ambiguities in a similar manner.

### 3.5. Conclusion

In the current chapter, I have reviewed two major strands of L2 WTC research: the psychological antecedents strand and the social co-construction strand. The difference between the two lay in whether intention is treated as something operating within the mind of the individual who happens to inhabit a given learning context, or something shared between individuals jointly attending to some aspect of the environment. L2 use is treated alternatively as the outcropping of a complex interaction of psychological and situational variables, or the emergence of two individuals trying to draw each other's attention to some aspect of the environment in an attempt to achieve some personally meaningful goal.

Where does a network approach belong among the L2 WTC literature? Certainly in the social co-construction strand, with behavior (L2 use) and structure conceptualized as exerting reciprocal influence in a cyclical fashion. Accordingly, the utility of a network approach is in describing who interacts with whom, thereby sharing their attention and activity towards the joint realization of personally meaningful goals, even if that goal is "just" the re-negotiation of their social identities as increasingly competent L2 users (e.g., Kurata, 2011). Networks are therefore useful in tracing communities in which individuals are likely to co-construct social reality as a result of repeated interaction with one another. In particular, a whole-network (sociocentric) approach allows one to look beyond the face-to-face processes by which individuals share social meaning. It permits one to look at the boundaries (or structural holes, according to Burt) between sub-communities of meaning, as well as the processes involved in the formation of those boundaries. Indeed, just such an approach is taken in Chapter 5.

Crucial for use within a social constructivist paradigm, however, a network approach does not deny that individuals have varied personal reasons for interaction. Indeed, one cannot lose sight of that assertion that "individuals communicate differently with different interlocutors when discussing different topics in different situations" (Cao, 2009, p. 201). A network approach must be

extremely cautious in advancing any specific motives driving interpersonal behavior. Rather, in line with a social constructivist perspective, humans are seen as having a broad range of needs and motives: some biologically derived and others learned, some pervasive and others constrained to particular situations and persons. Accordingly, the analyst must carefully consider the organizational/social context in deciding to what degree that context is the result of individuals' *specific, shared* motives; indeed, a social tie may very feasibly be the result of asymmetrical interpersonal motives, with one person's resources (i.e., the teacher's knowledge) satisfies the other's need (i.e., the learner's desire to learn). Therefore, an assumption is made that individuals must fulfill these motivations through interaction with one another. The analytical focus comes to rest on the degree and to which the fulfillment of two individuals' respective needs/motives are intertwined with one another.<sup>44</sup>

However, a network analytical approach is not a method for investigating situated L2 WTC, except perhaps to provide possible background within mixed methods studies. In all, a network approach is not about the moment of L2 use, but about the aggregation of those moments in establishing and maintaining one's social ties and wider network position. As a result, this approach is appropriate in longer-term developmental trajectories, rather than in the momentary rise and fall of L2 WTC within an interaction, though the two may complement each other well. Ultimately, such a perspective permits the researcher to address the notion of opportunity to interact, seeing who is relatively independent from any single other individual for interaction, and who is more reliant on a single interaction partner in order to fulfill social motives. In such a way, it is possible to ascertain who has an easier path to success in terms of entering into discourse, and who is constrained in their use of the L2.

---

<sup>44</sup> This recommendation is drawn from *interdependence theory*, originally advanced by structural social psychologists Harold Kelley and John Thibaut (see Rusbult & van Lange, 2003 for review). As quoted in Chapter 1, Kelley and Thibaut have long been reluctant "to invoke certain special social motives...to explain social phenomena," (Thibaut & Kelley, 1959, p. 4).

## Chapter 4

### L2 WTC and cross-cultural adaptation of sojourners

#### 4.1. Introduction

With the ever-expanding movement of individuals to all corners of the globe for the purposes of business, entertainment, education, economic opportunity and political asylum, the need to understand and facilitate intercultural contact grows more important every day. This rapid increase in movement across cultural boundaries has brought about the popularized notion of *culture shock* (Oberg, 1960), an all-encompassing term for the constant frustrations with daily social functioning encountered by immigrants and sojourners (i.e., businesspeople, students, and travellers on extended but finite stints abroad) in their attempts to fit into their new cultural environment. At its most severe, when immersed within a markedly different culture, we can find that many tacitly-held ways of behaving suddenly become excruciatingly noticeable, clashing with the behaviors and expectations of members of the host culture. The result is a wave of anxiety over knowing that engaging with the host culture will not come without unaccustomed effort. Immigrants and sojourners in the grips of culture shock must make a repeated choice: persist in engaging with the host culture, or withdraw from interaction, thereby restricting intercultural exchange. The choice to engage in intercultural communication is therefore a crucial aspect in understanding how individuals face these challenges to social functioning and the resulting anxiety, ultimately determining whether intercultural contact succeeds, fails, or deteriorates into outright conflict.

In the current chapter, I investigate the cross-cultural adaptation process of Chinese international students at a UK university. L2 WTC is presented here first and foremost as a framework of *purposeful* L2 use, shaping the encounters which affect daily functioning in a new cultural environment. In particular I assume L2 WTC to be the willingness to engage with the new

cultural surroundings, and thereby deal directly with challenges and threats, rather than turn inward. In all, I examine the role of L2 WTC as a potential key factor in sociocultural and psychological adjustment of these sojourners.

#### **4.1.1. L2 proficiency, acculturation, and adaptation**

Second-language (L2) proficiency has long been regarded of particular (and obvious) importance in the cross-cultural adaptation process. The field of L2 motivation has been centrally concerned with social-psychological antecedents of L2 proficiency, including cultural attitudes, identity, and acculturation to the target language group. Despite focusing on different social factors, various “social process models” of L2 acquisition have all centered in some way on the social processes involved in learning a L2, including the *social psychological model* (e.g., Lambert, 1973), the *social context model* (Clément, 1980), the *intergroup model* (Giles & Byrne, 1982), the *acculturation model* (e.g., Schumann, 1986), and ultimately, Gardner’s (1985) *socio-educational model*. However, these models attend primarily to the impact of social factors on ultimate L2 acquisition and proficiency, and are therefore less concerned with actual language behavior (Gardner, 1985).

By contrast, the ability to communicate effectively in the L2 lies at the core of a range of theories of intercultural adaptation (Gudykunst & Hammer, 1988; Kim, 1988; 2001; Gudykunst, 2005a; 2005b), which generally hold L2 proficiency as an essential component to the sojourner/immigrant successfully interfacing with the host culture. However, the relationship between L2 proficiency and L2 usage, although strong, is not always direct. Complicating the relationship is a variety of contextual, social, historical, and individual factors that impact an individual’s perception of his/her L2 ability, as well as the motivation and confidence to communicate in the L2 within or across various social situations (Clément, *et al.*, 2003).



This complex relationship is reflected within a number of studies that have directly addressed the effect of L2 competence on intercultural adjustment. When intercultural adjustment is conceptualized in a general way, such as in terms of satisfaction, lack of stress, or well-being, a positive relationship tends to emerge between L2 confidence and measures of adjustment in various groups, including students (e.g., Gullahorn & Gullahorn, 1966; Noels & Clément, 1996; Ying & Liese, 1991), immigrants (Masgoret & Gardner, 1999), and refugees (Nicassio, *et al.*, 1986; Waxman, 2000). Depending on the variables examined, however, this relationship can be mediated. For example, Masgoret and Gardner (1999) found that the relationship between a subjective rating of English ability and “well-being” among Spanish immigrants was mediated by host culture contact and assimilation and integration modes of acculturation.

On the other hand, when a distinction is made between what Ward and Kennedy (1993) term *psychological adjustment* (emotional wellbeing), and *sociocultural adjustment* (social functioning within the host environment), studies bear mixed results. For example, Ward and Kennedy found a positive relationship between L2 proficiency and measures of sociocultural adaptation, though not psychological adaptation, among students from New Zealand studying abroad (see also Chataway & Berry, 1989). Takai (1989; cited in Ward, *et al.*, 2001) even found a link between increased L2 proficiency and *dissatisfaction* among foreign students in Japan, a relationship which Takai maintains may be due to heightened expectations for acceptance and belonging that go unfulfilled.

In the eyes of a number of theorists, at the heart of this complex relationship between the cognitive ability to speak an L2 and cross-cultural adjustment is the idea that intercultural communication is transactional: it is an ongoing exchange between person and environment that allows the individual to confront threats and challenges to meet his or her personal goals and to establish a satisfactory level of basic social functioning. Communication’s role as an interface between person and environment underlies a comprehensive view of cross-cultural adaptation as

“the dynamic process by which individuals, upon relocating to new, unfamiliar, or changed cultural environments, establish (or re-establish) and maintain relatively stable, reciprocal, and functional relationships with those environments” (Kim, 2001, p. 31). Therefore, to gain perspective on this strong yet complicated relationship between L2 proficiency, L2 confidence, and L2 use, it is necessary to consider the exchange of resources that takes place between the individual and his/her surroundings.

The link between L2 ability and actual communicative behavior has also received considerable interest within the social psychology of language, with the past decade having seen increased interest in the notion of the willingness to communicate (WTC) in the L2 (MacIntyre, *et al.*, 1998; see Chapter 3). However, despite the significance of the complex relationship between L2 proficiency and L2 use on the part of sojourners and immigrants (commonly referred to within the literature as strangers; Simmel 1908/1955), the concept of L2 WTC has drawn scant attention within the literature on acculturation. Instead, L2 WTC has been predominately examined within foreign-language classroom contexts where acculturation is not an issue (e.g., MacIntyre, *et al.*, 2001; Yashima, 2002). Even when L2 WTC has been examined in contexts where acculturation and adaptation are relevant issues (e.g., bicultural contexts in Canada), researchers have tended to focus on L2 communication alone as the ultimate outcome, usually not measuring or commenting to any great extent on the various social ends for which the L2 is ultimately used (Clément, *et al.*, 2003; MacIntyre & Charos, 1996).

In an effort to begin filling this gap between models of situated L2 use and frameworks of adaptation, I first outline the notion of transactional person-environment *fit* as described within the literatures on stress and coping, cross-cultural adaptation, and an ecological perspective on language learning. These approaches commonly view personal functioning as occurring within a variety of individual, social, historical, and cultural contexts, though the approaches differ in terms of which processes of functioning, which contexts, and which populations are of interest. Nevertheless, they

share in the assumption that while each fit may be determined by a unique interaction of person and environment, the extent to which the individual is actively engaged in one's environment is crucial to understanding his/her cognitive, emotional, and/or social development.

Second, I test the general hypothesis that this willingness to engage actively with one's new surroundings – defined in terms of L2 WTC – facilitates an adaptive fit within a new culture. The research question is a simple one: Does L2 WTC serve as an antecedent to transactional stress among Chinese international students adapting to life in a British university? In asking this, I argue for the appropriateness of including L2 WTC – generally reserved for educational contexts – within more general models of adaptation.

#### **4.1.2. An ecological perspective on L2 WTC: Affordances and niches**

As discussed throughout this thesis, whether L2 WTC is conceptualized as a trait-like willingness to communicate in the L2, or a situational willingness co-constructed between interlocutors situated in a particular context, the notion of the *opportunity* to communicate takes a prominent, though usually assumed role. This might be because the notion of a “L2 opportunity” is diverse and open-ended, with many things, people, and situations constituting a potential site to use the L2, such as a co-national classmate within the foreign-language classroom, a host national on the streets of a foreign city, a radio broadcast originating from another country, a piece of paper on which to write a diary entry in the L2, and so on. All of these entities provide opportunities, or *affordances*, for using the L2. The question is what the individual either recognizes as, or transforms into, an opportunity.

An affordance is an element of one's environment that is perceived as salient in some way by the individual who is actively engaged with his or her surroundings (Gibson, 1986). In Gibson's words: “[t]he affordances of the environment are what it offers the animal, what it provides or furnishes, *either for good or ill*” (1986, p. 127; emphasis added). As the total environment is too

complex to perceive in its entirety, humans and other animals selectively attend to various aspects of the environment, including substances (e.g., air for breathing), surfaces (steps for climbing), objects (tools for working), and other persons/animals (enemies for fighting). As a result, affordances are neither objective nor subjective; rather, affordances are a “complementarity” between actor and environment (Gibson, 1986; van Lier, 2000). They are regarded as fundamentally relational: air *affords* breathing, steps *afford* climbing, and so forth.

Affordances are a central component of an ecological approach to language learning. Originating out of Vygotskian sociocultural theory (e.g., Lantolf & Thorne, 2007), an ecological perspective seeks to describe second-language learning as a process of personal discovery actively undertaken by each learner, of the ways in which the L2 is personally meaningful and important in everyday life (van Lier, 2000; 2004). This process of personal meaning-making is enabled as communicative competence and thought emerge out of one’s direct engagement with affordances. As discussed in Chapter 3 (see Section 3.3.1), language is derived from a larger human system of “semiotic activity” in which individuals (of potentially various levels of linguistic competence) are motivated to share their intentions with one another in order to accomplish their goals jointly. Language is inseparable from abstract thought because it is through language that one can take action on affordances not present in the current environment. Language is therefore the means by which individuals jointly transcend “the here and now” (Feuerstein, 1980).

Personal meaning-making is intertwined with learning to use the L2 in such a way as to satisfy these (newly-discovered) personal meanings. In particular, learning occurs through interactions between individuals by which the less-skilled individual achieves more than he or she would have been able to without the assistance of the other, more-skilled individual (van Lier, 2000; Lantolf & Thorne, 2007).<sup>45</sup> Therefore, knowledge of a language is externally co-constructed *between*

---

<sup>45</sup> This form of activity is (well-)known as the Zone of Proximal Development, or ZPD (e.g., Lantolf & Thorne, 2007).

individuals prior to becoming internalized by the learner. If taken far enough, language learners are pushed to deal with more and more removed affordances, requiring the individual to utilize increasingly complex linguistic forms to represent and to take action, such as describing individuals who are not present, making plans, directing others, and so on (van Lier, 2000). The learner thus moves beyond referring to and acting upon affordances within sight, and begins transcending the immediate context.

### ***L2 WTC and engagement with affordances***

Learning a L2 therefore entails actively seeking out and taking advantage of the affordances that one encounters. As van Lier (2000) notes, “[i]f the language learner is active and engages, she will perceive linguistic affordances and use them for linguistic action” (p. 252). The language learning process therefore depends to a considerable extent on various personal attributes that contribute to an overall tendency to actively engage with affordances. Applied to the development of language learners in particular, this notion of active engagement captures the conceptual core of L2 WTC. L2 WTC takes on the character of a developmental impetus, pushing the individual towards increasing levels of effectiveness.

Bronfenbrenner’s (1993) general theory of cognitive development affirms a developmental view of L2 WTC. He posits the importance of “developmentally instigative characteristics” that promote or forestall dispositions towards active engagement with one’s social environment. Among these attributes are *selective responsivity*, consisting of individual differences in how one appraises existing aspects of the physical and social environment, and *structuring proclivities*, or the tendency to actively and creatively engage with physical, social, and symbolic aspects of one’s environment in increasing complex ways.<sup>46</sup> The L2 WTC model resembles these tendencies, at least in part, though

---

<sup>46</sup> Bronfenbrenner (1993) also refers to *personal stimulus characteristics* (e.g., mood, physical attractiveness) which invite reciprocation by others, and *directive beliefs*, referring to one’s capacity to integrate their experiences into a sense of self as it relates to the environment, either adaptively or maladaptively.

with an added focus on their dynamic fluctuations. In this sense, trait-like L2 WTC pertains to a general disposition towards engaging with the variety of affordances in a new cultural environment.

### ***Person-environment fit***

In offering the notion of developmentally instigative characteristics, however, Bronfenbrenner (1993) is careful to note that these cognitive traits influence, but do not determine, the course of development. The ultimate developmental trajectory also depends on the resources afforded to the individual by virtue of his/her ecological *niche*. An organism's niche is the set of affordances in which it is directly involved. A niche therefore describes more "how" and less "where" an individual lives (Gibson, 1986). In terms of language learning, niches may be seen as containing varying "semiotic budgets" or levels of richness in potential linguistic affordances. It is this budget of affordances which may limit an individual's linguistic – and personal – development.

The notion of ecological fit is evoked by Gibson (1986), who notes that a "niche implies a kind of animal, and the animal implies a kind of niche" (p. 128). Accordingly, van Lier (2000) translates the notion of niche to language learning, likening knowledge of language to the relationship between an animal and the jungle:

... the ecologist will say that knowledge of language for a human is like knowledge of the jungle for an animal. The animal does not 'have' the jungle; it knows how to use the jungle and how to live in it. Perhaps we can say by analogy that we do not 'have' or 'possess' language, but that we learn to use it and to 'live in it'. Taking a semiotic perspective, we might amplify, and place language inside a more general scheme of sign-making systems. (p. 253)

In this view, a growing knowledge of language permits one to exploit one's various affordances in an increasingly effective manner. Just as a monkey's tail, feet, diet, and brain allow it to feed, reproduce

and be safe among the trees, an individual's L2 skills allows him or her to live effectively and variedly in an L2 environment.

Bronfenbrenner (1993) maintains that different niches may be more or less conducive to different individuals with varying personal attributes. While an individual, like an animal, is in large part a reflection of his/her environment, he/she may also (unlike most animals) intentionally act upon his or her environment, restructuring and reinterpreting it in such a way to better afford him/her additional (language) opportunities. Given the level of personal meaning potentially imbued in learning an L2, a dearth of linguistic affordance may prompt an individual to seek out alternative surroundings to fulfill those meanings.

However, a radical shift in ecological niche – such as those associated with any major life change – likely comes with a penalty in initial fit. Individuals may find themselves unable to navigate, negotiate, and “tap into” the intersubjective meanings of the host community. Commonly referred to as *strangers* (Simmel, 1908/1950), these individuals possess deficient knowledge of the semiotic systems which permit one to operate effectively in the new surroundings. In light of van Lier's (2000) analogy, the stranger is akin to Little Red Riding Hood, dropped into the woods unsure of or oblivious to his or her surroundings. The central hypothesis within the current chapter is therefore that L2 WTC – as the intention to actively engage with one's new cultural surroundings through use of the L2 – plays an essential role in re-establishing a proper *fit* between the sojourner and his/her new ecological niche within the host environment.

### ***Adaptation, stressors, and transaction***

A prominent example of such intentional, purposive action that results in a drastic restructuring of one's communicative affordances is the migration undertaken by immigrants and sojourners. Researchers investigating the cross-cultural adaptation process of these individuals have relied extensively on some notion of person-environment fit or (dis)equilibrium in various attempts

to formulate general theories of intercultural communication and adaptation. These theories owe much to a general, transactional framework of stress and coping, in which stress is viewed as “a relationship between the person and the environment that is appraised by the person as taxing or exceeding his or her resources and as endangering wellbeing,” (Folkman, *et al.*, 1986, p. 572). Transactional theories of intercultural communication and adaptation therefore share a basic common ground with an ecological perspective on language learning. Individuals’ are broadly seen as having personal “resources”: cognitive abilities, adaptive affective tendencies, behavioral skills, access to information, and material goods through a network of social relationships. Individuals use these to confront challenges, meet goals, and generally make life easier.

Underlying theories of stress and coping – most notably the cognitive theory of psychological stress and coping (Lazarus & Folkman, 1984) – is the fundamental idea that how an individual subjectively interprets a situation shapes his or her behavioral response, and emotional reaction. With stress being a subjective process, the individual carries with him or her certain parameters that help to frame the threat posed by a given situation or event. These are set in relation to the individual’s repertoire of learned skills, beliefs about the efficacy of those skills, and a “range of personality characteristics including values, commitments, goals, and beliefs about oneself and the world” (Folkman *et al.*, 1986, p. 572) to assign meaning and relative importance to the situation. Much of the subsequent research has therefore focused on how individual differences in these parameters lead to different stress experiences and coping outcomes.

In particular, an individual interprets an environmental or social stimulus as a *stressor* when he/she determines that the stimulus: (1) represents an important threat or challenge, and therefore is necessary to address (a process known as *primary appraisal*), and; (2) requires an unaccustomed level of effortful behavior in order to manage or avert it successfully (*secondary appraisal*) (Lazarus & Folkman, 1984). Harmful/threatening stressors can take the form of major life events (e.g., death of a loved one, major injury, etc.) or *daily hassles* – irksome daily occurrences that can accumulate



over time, taxing the individual's resources, and potentially resulting in mood disturbance, depression, and physical ailments (DeLongis, *et al.*, 1988).<sup>47</sup> Subsequently, perception of a stressor can lead to emotional or physiological stimulation, known as a *stress reaction*, which can be experienced as anxiety or excitement, depending on the level of arousal and the nature of the stressor as beneficial or harmful.

Subsequently, individuals engage in effortful coping behaviors to manage this taxing of one's resources through a variety of *coping strategies*. A number of emotion-focused coping strategies help one deal with the stress reaction (e.g., denial, tunnel-vision). Conversely, *problem-focused* coping strategies are employed in order to actively manage the stressor itself (Lazarus & Folkman, 1984). While the former are relatively finite, the latter may be as diverse as the problems they are meant to address.

Overall, appraisal and coping processes can be regarded as the subjective counterpart to an ecological perspective on affordances and engagement. The perception of an affordance as beneficial or detrimental (primary appraisal) and its evaluation as a stressor (secondary appraisal) can be seen as the phenomenological product of the individual's developmentally instigative characteristics which orient the individual towards affordances and propel his/her to engage actively.<sup>48</sup>

#### **4.1.3. Cross-cultural adaptation and communication: Links to L2 WTC**

##### ***Adaptation as outcome***

A general social psychological approach to the study of sociocultural and psychological adjustment among sojourners has relied extensively on stress and coping frameworks as applied

---

<sup>47</sup> Less well-researched, beneficial stressors are sometimes referred to as *daily uplifts*, such as learning opportunities.

<sup>48</sup> However, in contrast to an ecological take on language learning, a stress and coping approach remaining firmly focused on the inner experience, rather than seeking to cut across subjective-objective dichotomies, as sought by ecologists such as Gibson (1986).

specifically to the migration experience. The general assumption is that the shift in sociocultural milieu represents a major life event, presenting the migrant with numerous stressors that necessitate a variety of coping responses, and put one's reservoir of personal resources to the test. At the core of stress and coping frameworks of cross-cultural adjustment, therefore, is an emphasis on the various sociopolitical, economic, and individual contexts, as well as the various personal characteristics, that predict the migrant's overall level of sociocultural and psychological functioning within his or her new cultural environs.

For instance, a general model of cross-cultural adjustment offered by Berry (1997; see also Ward *et al.*, 2001) highlights the general stream of social and cognitive processes that occur as part of migration and settlement. This framework outlines various contextual and personal factors that come into play prior to migration and throughout the acculturation process, resulting in short- and long-term outcomes. Berry (1997) therefore incorporates both macro-level characteristics of the home and host societies (e.g., social attitudes, demographic factors), and individual-level factors addressing the person's ability to appraise and cope in an adaptive manner. Importantly, however, the model lacks any situated component; micro-level processes associated with the actual experience of individual stressors are neglected. Instead, cognitive appraisal and coping are viewed in general, trait-like terms, with the ultimate aim of describing differential long-term outcomes of psychological and sociocultural adjustment for the individual immigrant or sojourner.

As a result, this and similar models largely forego theorizing the interceding role of communication or interaction itself within the adaptation process. While, notably, Ward and Kennedy's (1993) conceptualization of sociocultural adjustment does rest on person-environment fit, subsequent theories use this notion of fit as an outcome or a predictor of adjustment, rather than as a step in a recurring process of ongoing adaptation. Berry (1997) makes use of the notion of sociocultural adjustment, subsuming communication under intergroup "contact and participation" and long-term modes of acculturation (i.e., assimilation, integration, segregation/separation, and

alienation) which characterize contact patterns over an extended period of time. In this fashion, intercultural communication either plays out an assumed role within other psychological and sociological variables (such as social support, personality, etc.), or is treated as a fairly *constant* independent or dependent variable (see Kim, 2001).<sup>49</sup>

### ***Transactional theories of intercultural communication***

A number of communication theorists, however, have elaborated on the person-environment transaction in order to address cross-cultural adaptation as an on-going, developmental process. In this view, communication is seen not merely as an independent or dependent variable within a linear process, but as the basic, continuous, back-and-forth negotiation between what daily life requires of the stranger, and what he/she can offer up in an attempt to meet his/her goals. Accordingly, the role of communication within general theories of cross-cultural adaptation is paramount, leading theorists to base the very concept of adaptation around the flow of messages, and well as the ability to encode and decode those messages quickly, effectively, and as they were intended. It is within such a transactional conceptualization of adaptation that L2 WTC may find a more central role within the process of adaptation, serving as the interface between person and environment, linking affective, cognitive, behavioral, and contextual/environmental. As one may therefore expect, L2 WTC holds much in common with these theories. I look at two in particular: *anxiety/uncertainty management* (AUM; Gudykunst & Hammer, 1988; Gudykunst, 2005a; 2005b), and Kim's (1988; 2001) integrative theory of communication and cross-cultural adaptation.

### **Anxiety/uncertainty management**

Originally adapted from *uncertainty reduction theory* (Berger & Calabrese, 1975), AUM holds that individuals seek out information to enhance their ability to predict and explain the actions of others in order to avoid negative consequences. Uncertainty and anxiety are the interrelated "basic

---

<sup>49</sup> As we will see in Chapter 4, theorizing interaction as occurring within discrete instances affords the opportunity to better explain communication as interdependent.

causes” of (in)effective intercultural communication. Anxiety and uncertainty are interrelated. When facing a potential interaction with a host national, a sojourner is likely to experience anxiety if he/she cannot predict how a host national will interpret or behave within an interaction, or explain retrospectively why a host national has behaved in a certain way. Consequently, this anxiety inhibits communication process, making interactions less effective, or less frequent, and contributing to continued uncertainty regarding host nationals.

Anxiety and uncertainty are therefore reciprocally influencing processes that impact communication when certain thresholds are exceeded. Keeping anxiety and uncertainty within an optimal range is therefore the key to facilitating effective intercultural communication. When kept within tolerable limits, emotional arousal and uncertainty are adaptive. The sojourner is interested or excited by the novelty of the host culture, spurring interaction to satisfy the curiosity that arises from not knowing everything there is to know about one’s new surroundings (Gudykunst, 2005b). However, if uncertainty and emotional arousal exceed upper or lower tolerances, interactions become aversive. If too high, anxiety results, leading to premature severance or outright avoidance of intercultural contact. Conversely, if there is too little uncertainty and emotional arousal, the individual will quickly become uninterested in the interaction, with similar results (Gudykunst, 2005b).

AUM goes on to posit that anxiety and uncertainty fluctuate in accordance with changes in numerous “superficial causes” outlined within the model, leading to either successful intercultural communication, or an ineffective and/or aborted attempt. Similar in structure and content to the L2 WTC distal-to-immediate pyramidal heuristic model (see Section 3.2.1), the AUM schematic postulates a range of axioms by which these superficial conditions impact anxiety and uncertainty.<sup>50</sup>

---

<sup>50</sup> These axioms reach into the dozens (47 in Gudykunst, 2005b, down from 96 in an earlier version). Indeed, Ward et al. (2001) echo the common criticism of AUM that its proliferation of axioms is “theoretical excess.” In response, Gudykunst asserts that his theory is meant to also play a pedagogical role, providing sojourners with a more concrete idea of what may impact their own communication and adaption process.

These conditions take into account a broad range of personal, situational, and social factors surrounding intergroup contact, including one's knowledge of the host culture and its language, one's self-concept (e.g., social identities, self-esteem), motivational processes, various intergroup attitudes, and patterns relationships with host nationals, among many others.

An implicit transactional view of the communication process is therefore at play within AUM. According to this viewpoint, instances of cross-cultural communication are regarded as fundamentally ambiguous, stress-provoking events (Gudykunst & Hammer, 1988). A stranger's ability to communicate effectively is based on his or her ability to predict and explain the behavior of host nationals by drawing on cognitive resources (knowledge of the host environment). In transactional terms, the environment places a demand to which the individual must respond with personal (cognitive) resources – in this case, knowledge of the host environment. More resources of this sort subsequently ease anxiety, keeping it below an upper threshold at which communication breaks down.

However, at the crux of AUM is an implicit focus on the cognitive and social development of the individual. Affirmed is the general inquisitiveness of the individual, driving him/her forward to engage with and learn about his/her surroundings. Furthermore, the inclusion of the notion of *mindfulness* (Langer, 1989) attests to its pedagogical/developmental aims. Mindfulness is generally described as a social flexibility and heightened awareness of one's current environment, composed of various broad strategies in which we seek to expand how we categorize members of the host culture, thereby establishing common ground and a basis for empathy, rather than division. When we are mindless, we are "automatons" who react to our environment according to past behavior. In contrast, when we are mindful, we are exercising a heightened awareness of our own cognitions and behaviors coupled with a greater sensitivity towards the numerous cultural perspectives that may exist within the new cultural setting (Gudykunst, 2005b). In other words, "when we are mindless,

our behavior is rule- and routine-governed; when we are mindful, rules and routines may guide our behavior rather than predetermine it” (Langer, 2000, p. 220).

In all, Gudykunst and Hammer’s (1988) incorporation of mindfulness into AUM underlines how individuals may, or may not, effect change upon their situation: “sometimes our communication is ‘determined’ by our personalities or the context (i.e., when we are mindless), and sometimes our communication is based on ‘free will’ (i.e., when we are mindful),” (Gudykunst, 2005b, p. 427). The implication is that just because something is stressful, it is by no means universally negative and to be avoided. Rather, social encounters can be sites of personal development and growth, if managed properly. Ultimately, the exercise of mindfulness allows for personal growth and development, permitting one to make active changes in usual patterns of communication, and questioning the value of one’s repertoire of learned behaviors and cognitions. Nonetheless, Gudykunst remains focused mostly on the cognitive and affective processes within the individual; less attention is paid to his/her ongoing, dynamically changing relationship with the external environment.

### **Adaptation as stress-adaption-growth**

This developmental perspective is expanded on by Kim (1988; 2001). However, Kim devotes considerably more attention to the way in which the stranger connects to the host society via communication. She regards communication as the two-way interface by which internal states and abilities interact with the external world, affecting each other dynamically. As an interface, communication is regarded as having two, inseparable aspects: personal and interpersonal.

The personal aspect of communication refers to the individual’s internalization of the host communication. Kim (2001) maintains that strangers’ stage of adaptation may be evaluated in terms of the degree to which this internalization corresponds to that of natives:

The capacity of the personal communication system serves as the innermost dimension in the structure of cross-cultural adaption, enabling strangers to organize themselves mentally, motivationally, and emotionally in and with their sociocultural milieu, developing ways of seeing, hearing, understanding, and responding to the environment appropriately and effectively. (p. 72)

Kim (2001) refers to this internal capacity as *host communication competence*, defining it as the self-powered entity which “empowers strangers to participate and maximize successes in social processes of the host environment,” (p. 97). It is the internal drive that pushes the individual away from a purely co-ethnic environment and into the host society and culture. It represents the interlocking combination of cognitive factors (e.g., pragmatic knowledge of communication rules; developed mental schemas of the host culture), affective factors (e.g., motivation to participate socially in the host environment; a culturally-adaptable sense of self and other), and behavioral factors (e.g., basic language and job skills, creative use of personal resources in problem-solving). Furthermore, it is conditioned by less immediate factors, including various person factors that predispose an individual to change and adapt well (e.g., personality, similar ethnicity), and environmental factors (e.g., receptivity of the host culture).

The interpersonal aspect of communication is termed *social communication*, referring to the external realization of the individual’s internal communication system (Kim, 2001). It is conceived of partially in terms of communication with other individuals, providing opportunities for meaningful social exchange.<sup>51</sup> Notably, Kim postulates the importance of personal (ego-centric) networks of interpersonal communication, focusing on a few rudimentary network features. In particular, she indicates the importance of the number and intimacy of ties with members of the host community,

---

<sup>51</sup> Additionally, it is also conceived of in terms of mass media consumptions, which likely exposes the stranger to prevalent stereotypes found within the host community.

and the proportion of host ties to ethnic ties.<sup>52</sup> She argues that these features boost the frequency and quality of interaction between stranger and host, facilitating the stranger's development. In all, Kim's network hypotheses can be boiled down to the notion that "more is better," which, while inarguable, lacks the nuance in social processes that a network approach can otherwise provide.

The personal-social communication distinction may roughly correspond to the split between dispositional and situated L2 WTC. Host communication competence largely corresponds to the notion of communicative competence found within the L2 WTC model. It is the latent "off-line" capacity that influences whether or not one first chooses to engage with an opportunity to interact. It also involves general motivational components, including "adaptation motivation" and identity flexibility. Ultimately, the primary difference between Kim's model and the L2 WTC model lies in how the two incorporate temporality. While the L2 WTC is concerned with momentary states of confidence and interpersonal desires, Kim's (2001) model focuses on long-term fluctuations and developmental trajectories.

Meanwhile, a rough correspondence exists between social communication and situational L2 WTC, as both refer to the realization of communicative competence within interactive encounters between interlocutors. However, Kim's notion of social communication is not an explicitly situational one; it is conceived of mainly in terms of persistent relationships and patterns of media consumption, rather than in discrete, interrelated communicational events. As such, it lacks any conceptualization of situated co-construction of knowledge, instead favoring more enduring patterns of interpersonal influence. However, importantly, it does note a counteracting tension between host and co-ethnic ties in the learning process which will be relevant to the research hypotheses in Chapter 5.

---

<sup>52</sup> Kim (2001) also offers a notion of *centrality* of host ties within the ego-network. Though this bears absolutely no resemblance to any notion of centrality found within the literature, it does seem to correspond to a general idea of proximity. She also does, however, make passing reference to the notion of brokerage, which, is covered in Sections 2.3.1 and 5.1.2.



Kim (1988; 2001), therefore, also relies extensively on a transactional viewpoint, basing her general theory of cross-cultural adaptation explicitly around the concept. She views adaptation as a process rather than an independent or dependent variable, arguing that acculturative stress is the result of an imbalanced transaction between person (resources that are available) and environment (demands upon those resources). She sees communication as the core process by which a stranger's behavior is continuously, correctively shaped by the new social environment. Host communication competence serves as the central mechanism within a *stress-growth-adaptation* dynamic in which a stranger's social participation (through personal social networks and mass communication) repeatedly places him/her within stressful situations that disrupt the person-environment equilibrium. Such environmental stressors challenge the individual's cognitive, affective, and operational (behavioral) competencies: "The conflict is essentially... between the existing conditions inside the stranger and the demands of the external environment." (2001, p. 55). Central to the theory, however, is that this disequilibrium is a necessary aspect of the adaptation process. Confronting stressful situations that arise through social participation repeatedly provides opportunities for personal growth. This dynamic cycle diminishes in intensity over time, thereby encapsulating a process of adaptation.

AUM and host communication competence are therefore quite similar to L2 WTC in focus, content, and structure. All three represent a situated coalescence of affect, cognitive and behavioral factors that impact how intercultural communication unfolds. One major potential difference between these constructs and L2 WTC, however, is that neither AUM nor host communication competence are considered as traits. Instead, they are dynamic concepts conditioned by personal traits, as well as the situation, and the socio-cultural milieu. While this lies in contrast to the trait-like conceptualization of WTC as more enduring and trait-like, AUM and host-communication competence bear striking resemblance to the notion of WTC as a dynamic entity co-constructed between interacting individuals.

The dual-notion of L2 WTC, just like the personal-social communication distinction made by Kim (2001), is useful in that it highlights the connections between both the dynamic, moment-to-moment management of an interaction, as well as longer-term, learned tendencies across a number of interactions. When viewed as a disposition to communicate across situations, L2 WTC might be viewed as a tendency to rely on members of the host society as a resource for coping, opening the door for usage of a number of skills and abilities (e.g., L2 proficiency, academic knowledge) relevant to meeting a given demand. When conceived of specifically as a dynamic concept, L2 WTC lies at the cusp of the person-environment transaction itself. It represents the individual's deployment of his or her communicative competence and other forms of knowledge in order to confront a challenge or threat – small or large. This culmination of cognitive, affective, and situational factors propels the individual to “cross the Rubicon” (Dörnyei & Ottó, 1998) of intercultural communication.

#### **4.1.4. The current study**

The current study focuses on Chinese international students studying at a British university. During the 2006/07 academic year, students from the People's Republic of China alone numbered nearly 50,000, making it by far the largest single group of international students (UKCISA, 2010). With their large and growing presence in western universities, students from East Asia represent an especially important contingent of sojourners, and thus, strangers and potential sufferers of culture shock.

This group has generally demonstrated profound issues in their levels of the willingness to communicate in L2 English (Wen & Clément, 2003). Despite a large number of these students placing an expressed priority on learning English, many nonetheless find their stay abroad difficult, prone to the same feelings of loneliness, uncertainty, and academic difficulties as their host-national counterparts, as well as suffering from additional troubles associated with communication problems and differences in academic culture (Chataway & Berry, 1989; Ying, 2005). These problems may be compounded by socio-cultural values prevalent in China and the greater region, including an intense

level of face-protection, a sublimation of the individual self, and deference to authority. As played out in the English-language classroom, these factors often produce students who are especially reluctant to speak up in English (Wen & Clément, 2003). A major research project at the same site as this study found that many Chinese students experience profound anxiety over using the L2, especially outside the classroom, despite an expressed desire to integrate into host-culture networks (Dörnyei, *et al.*, 2004). The result for most is relegation to an “international ghetto” strongly suggesting that (involuntary) segregation and perhaps even marginalization are prominent modes of acculturation within the Chinese international student community within many British universities.

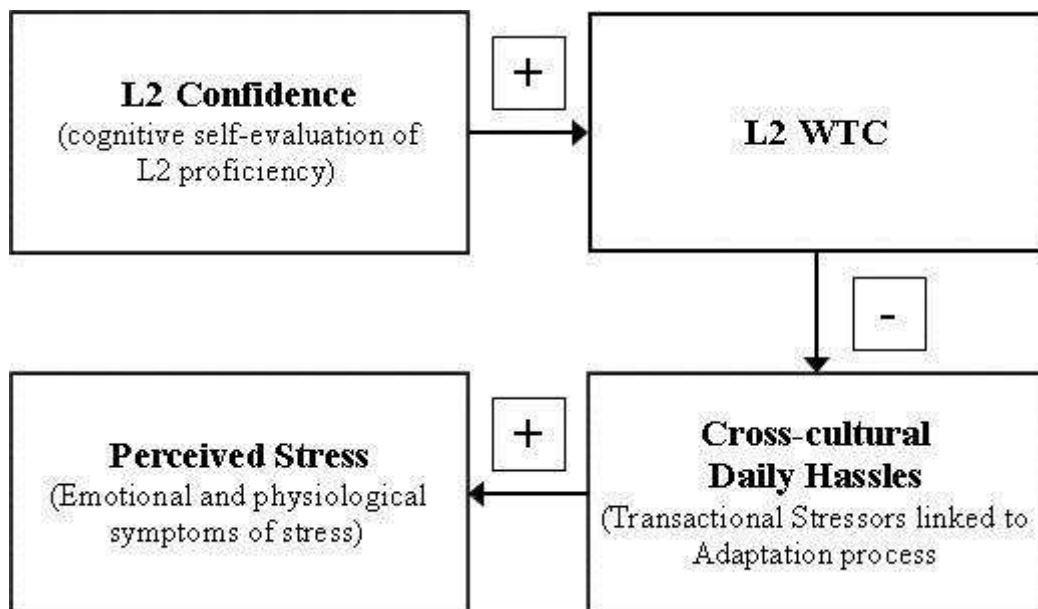

**Figure 3.1.** Theoretical Model

It is within this context of international Chinese students that the current chapter focuses on the relationship between L2 WTC and the process of cross-cultural adaptation. The aim is modest, simply asking whether L2 WTC among this group of students – measured as a cross-situational disposition to communicate – serves as a predictor of enhanced person-environment fit, as measured by daily hassles associated with acculturation. I hypothesize that L2 WTC plays a stress-preempting role, leading to fewer daily acculturative hassles. The theoretical model is presented in Figure 3.1. More specifically, the research hypotheses are that:

- The previously found links from L2 self-confidence to L2 WTC, and from Daily Hassles to Perceived Stress, will be replicated.
- A predictive, negative relationship will be found from L2 WTC to Daily Hassles.

## **4.2. Methods**

### **4.2.1. Participants**

Participants included 104 university students studying in Central England. All participants were native-speakers of a Chinese language and were from several Asian countries where Chinese-speakers represent a significant portion of the population (73 from China, 12 from Hong Kong, 17 from Taiwan; 1 from Singapore, and 11 from Malaysia).

To be selected for the study, participants had to have been in the United Kingdom for at least 4 months. The reason for this criterion was several-fold: to avoid including participants still in a 'honeymoon period' (Ward, *et al.*, 2001) which might skew the measures of well-being; to make sure that participants had a period of time to develop new relationships within the university environment, and similarly, to focus on students who are attending the university for a longer period, and thus are presumably more motivated to develop new relationships within the university environment; the average length of their stay in the local area was 12.5 months ( $SD = 11.8$ ). One participant was excluded because she had grown up in an English-Chinese bilingual household. Participants represented a range of degree levels (29 undergraduates, 45 masters-level, 17 doctoral, and 2 postdoctoral; 10 did not specify). There was a disproportionately high number of females (69.3%; 70 females, 31 males; 3 did not specify).

### **4.2.2. Instruments**

*Perceived L2 Competence Scale.* Participants evaluated their proficiency in L2 English in four areas: reading, writing, listening, and speaking using a 7-point rating scale (Clément & Kruidenier, 1985; see

Appendix E.1.3.), ranging from 1 (*not at all fluent*) to 7 (*completely fluent*). Scores were combined to reflect overall confidence in English (4 items,  $\alpha = .90$ ).

*Willingness to Communicate Outside the Classroom Scale.* A L2 WTC scale, originally used by MacIntyre *et al.* (2001; see Appendix E.1.1.), was selected for the relatively concrete nature of the situations it outlines (e.g., 'Take directions from an English speaker.'). Given the fact that participants completed the questionnaire without supervision, the ease of interpretation that this scale afforded was considered highly advantageous. Within this scale, only the items pertaining to speaking and comprehension outside the classroom were used for three reasons: questionnaire length considerations; classroom-related activities described within other items were too rudimentary given the participants' academic level; and, to focus on situations in which participants had the most volitional control over their use of English, which can often be diminished within classroom settings (MacIntyre, 2007), and may vary by area and level of study.

The scale included 13 items pertaining to the L2 WTC outside the classroom. Participants were asked to indicate how willing they would be to communicate using a rating scale from 1 (*almost never willing*) to 5 (*almost always willing*). A factor analysis was conducted using principal axis factoring with direct oblimin rotation because of the significant negative skew of these data. Differing slightly from MacIntyre *et al.*'s (2001) speaking and comprehension subscales, two factors emerged in the current study: one generally corresponding to L2 WTC in general social situations (6 items,  $\alpha = .77$ ), a second relating to WTC in task-like situations which are much less ambiguous, either through explicitly provided instructions, or clear-cut social roles (6 items,  $\alpha = .86$ ).

*Cross-cultural Daily Hassles Scale.* Using an adapted version (Rubinfeld, *et al.*, 2007; see Appendix E.2.1.) of the Daily Hassles scale (Kanner, *et al.*, 1981) participants indicated the degree to which a set of difficult yet common daily situations were a source of annoyance or conflict over the prior month. Hassles ranged from loneliness and financial problems to having to interact in English and

put up with certain unfamiliar living situations. Ten items closely resemble ones from the original 117-item scale. Changes included slight wording alterations, alterations to condense several items into one,<sup>53</sup> and adjustments specifically reflecting intercultural and academic contexts, appropriate to this study. A further three items were more generally adapted from original items to further address hassles associated with linguistic and cultural differences. Using a 5-point rating scale, participants rated the salience of each daily hassle from 1 (*absence of annoyance or problems*) to 5 (*major source of annoyance or problems*) (13 items,  $\alpha = .86$ ). Factor analysis was conducted using principle axis factoring with direct oblimin rotation because of a significant positive skew of this data.<sup>54</sup> This revealed 3 subscales: time and financial constraints (3 items,  $\alpha = .74$ ), social isolation (5 items,  $\alpha = .76$ ), and communicating hassles related to expressing oneself in a foreign language and culture, coupled with meeting academic standards (4 items,  $\alpha = .75$ ). This final factor included two of the three generally adapted items addressing intercultural hassles.<sup>55</sup>

*Perceived Stress Scale.* Perceived stress was measured by means of an abridged version of the Measure of Psychological Stress (Lemyre & Tessier, 1988; see Appendix E.2.3.). Factor analysis using principal axis factoring with direct oblimin rotation indicating revealed two factors (2 items,  $\alpha = .87$ ; 3 items  $\alpha = .64$ ) related to various feelings of anxiety and related physical symptoms over the prior four to five days. Participants responded using an 8-point rating scale from 1 (*not at all*) to 8 (*enormously*). This measure may also be considered an indicator of short-term psychological adaptation.

---

<sup>53</sup> For example, several items concerning money become 'Not enough money for essentials.'

<sup>54</sup> Costello and Osbourne (2005) recommend maximum likelihood for data that do not violate normality, and principal axis factoring for skewed data. Furthermore, they recommend using oblimin rotation over orthogonal rotation methods, as the former permits factors to be correlated – a reasonable assumption within psychological studies.

<sup>55</sup> Communication difficulties included four items: two generally adapted items ('To have to speak English,' 'Do not understand English well enough'); and two items closely resembling original items ('Anxiety regarding your ability to meet student standards,' 'Difficulties explaining your thoughts in order to be understood').

### **4.2.3. Procedure**

Participants were recruited through a variety of strategies including general advertisements, email announcements, personal approaches made by the researcher, and snowball sampling. Participants who responded to the various recruitment efforts were asked to verify that they fit the eligibility requirements, and were given the option of either completing a paper version of the questionnaire, or completing an online version through the ASSET questionnaire platform created by Bert G. Wachsmuth and operated by Seton Hall University. A small allowance was offered to those who participated. The participants were notified that participation was optional and that it would not affect their standing in any way at the university. The participants of this study thus represented a filtered convenience sample.

### **4.3. Results and Discussion**

Despite the lack of prior subscales for the selected instruments, factor analysis was conducted on all scales (except for L2 confidence) for the purpose of constructing a full structural equation model (SEM). While a path model or a structural equation model using single indicators would have been possible (Hayduk, 1987), use of latent variables with multiple indicators allowed for consideration of the potential role of communication-related hassles apart from other hassles not directly related to L2 communication. Given the focus on L2 WTC, it was deemed appropriate to consider the particular role of communication-related hassles. Indeed, as expected, factor analysis revealed a communication-related factor alongside two others. While this renders the model somewhat more complex, it permits important analyses which would otherwise not be possible.

Subsequently, the theoretical model (see Figure 3.1) was tested using SEM with AMOS 7.0. As mentioned above, a number of factors were found to be significantly skewed: the three daily hassles factors and the second perceived stress factor were significantly positively skewed ( $>2$  standard deviations of skewness above 0), while all three WTC factors were significantly negatively skewed. As a result, the SEM was conducted using a bootstrap method with 500 iterations

(Garson, 2009). Figure 3.2 presents the empirical model. A number of fit indices indicated a good fit for the data (Table 3.1). Modification indices suggested additional covariances between error terms. In a stepwise fashion, covariances were added between the error terms for self-rated L2 proficiencies in speaking and in listening. Next, this step was repeated for the error terms for WTC in general social situations, and for the social isolation factor under daily hassles. These covariances are justifiable. Responses for speaking and listening competence – both needed for face-to-face communication – should be tightly linked, even when compared to competencies in reading and writing. It is reasonable to assume that judgments of one’s own speaking and listening abilities are based on the same social interactions, resulting in similar response patterns. As for the second covariance, one who is suffering from social isolation presumably bases that judgment at least partially on how often he or she initiates interaction with others in informal situations. The modification indices also suggested another specific set of other links, which will be addressed after discussing the empirical model.

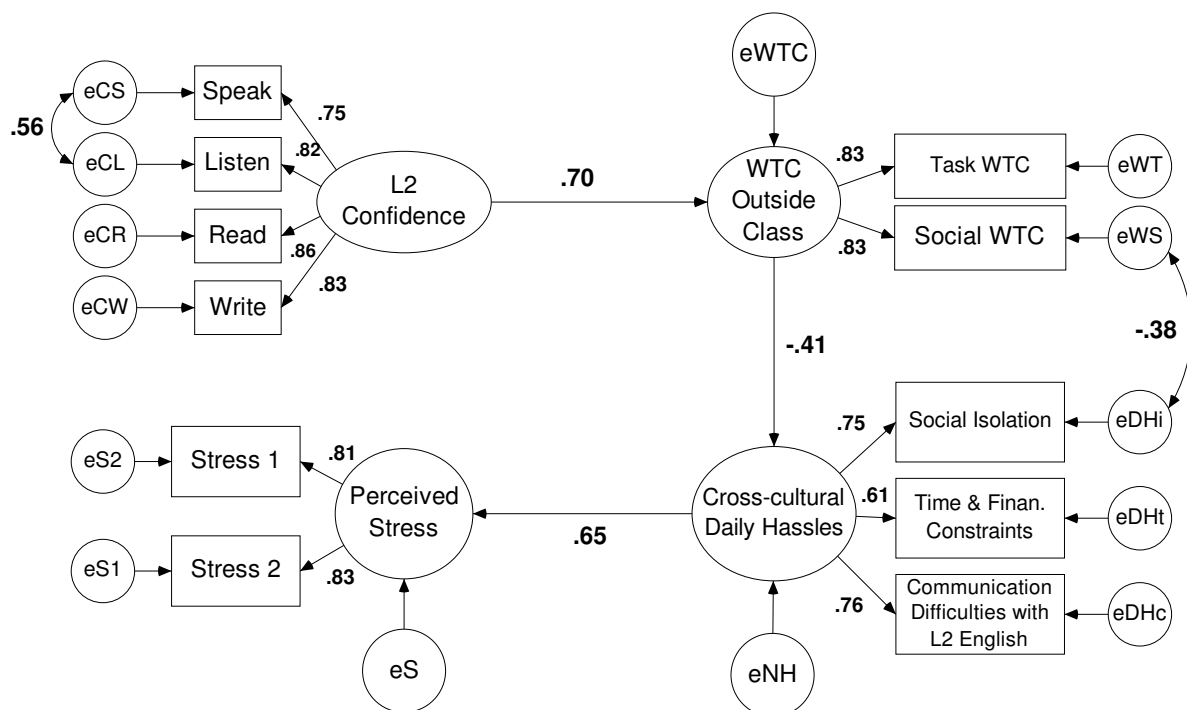

**Figure 3.2.** Empirical Model



The primary aim of this study was to investigate whether L2 WTC is a predictor of transactional stressors among international students, thereby supporting a place for the L2 WTC model (MacIntyre, *et al.*, 1998) within theories of intercultural adaptation. First, as hypothesized, a significant, predictive relationship was found from L2 confidence to L2 WTC outside the classroom. This finding is consistent with a key theoretical tenet of the L2 WTC model: that L2 confidence is an antecedent of L2 WTC. However, it is important to note that given the questionnaire design of the study, the possibility of investigating the immediate theoretical antecedents of specific instances of L2 use was not possible. Instead, L2 WTC is treated here as a general tendency to communicate in the L2 across situations – or to what extent the individual estimates that he or she will initiate communication in English whenever opportunities to do so arise. Accordingly, it supports a link between efficacy beliefs (i.e., L2 confidence) and behavioral intention (L2 WTC), as specified within the theory of planned behavior (Ajzen, 2005; see also Section 3.2.1).

**Table 3. 1.**

	Model fit indices					
	$\chi^2$	df	CFI	GFI	IFI	RMSEA
Empirical model (pre-modification)	67.1	41	.900	.900	.955	.079(.042-.112)
Empirical model (post-modification)	42.1	39	.994	.937	.995	.028(.000-.076)
Divided hassles model	32.4	38	1.000	.950	1.01	.000(.000-.053)

CFI = comparative fit index; GFI = goodness of fit index; IFI = Bollen's incremental fit index; RMSEA = Root mean square error of approximation (90% confidence interval)

Second, the negative path from L2 WTC outside the classroom to cross-cultural daily hassles addresses the main research question, confirming the hypothesis that L2 WTC predicts strangers' experience of cross-cultural stressors. This path suggests that those students who are more willing to initiate L2 communication are less burdened by social isolation, time and financial constraints, and communication difficulties. L2 WTC thus appears to serve as a mediator between L2 competence and cross-cultural network hassles, signifying a possible interface between a cognitive variable and an environmental one. This mediating role may therefore explain a number of studies bearing mixed results as to the relationship between L2 proficiency and cross-cultural adjustment.

While L2 proficiency is essential to establishing a functional person-environment fit, it is the actual (effective, voluntary) use of the L2 which is the deciding factor. As specified in the L2 WTC model, such use is affected by a range of variables, in addition to confidence.

Lastly, the positive path from daily hassles to perceived stress in the empirical model (from network hassles to perceived stress in the divided hassle model) supports a fundamental finding within the stress and coping literature that accumulation of environmental stressors leads to psychological and physical manifestations of stress, including anxiety and various outward symptoms. As applied to cross-cultural adaptation, this relationship represents the positive link between sociocultural adjustment (adaptive social functioning) and psychological adjustment (emotional well-being).

#### **4.3.1. The role of communication difficulties**

However, as mentioned above, SEM modification indices for the empirical model also suggested strong links between all four indicator variables of L2 confidence and a single factor within cross-cultural hassles – namely, difficulties with L2 communication. Accordingly, an additional ‘divided hassles’ model was tested (see Figure 3.3) in which the communication difficulties factor is treated as a single-indicator latent variable separate from the other sets of hassles, with a path leading from L2 confidence to this new latent variable. The remaining hassles (social isolation, time and financial constraints) can be conceived of in terms of hassles related to one’s personal network, assuming that one’s social network plays a vital role in obtaining the support and resources that would encourage social participation, and provide valuable assistance and information that saves time and opens up financial opportunities. This model also produced a good fit (see Table 3.1).

There is a two-part justification for this division that is underpinned by a network perspective on human social interaction. From a transactional/adaptation perspective, this split reflects Kim’s (2001) view that social participation affects the flow of information across a structure

of network ties. Building relationships with host nationals should facilitate the flow of social support and personal resources among individuals. Those sojourners who possess more strong ties to host nationals – and fewer strong ties with co-ethnics – should thus have advantaged access to information, resources, and opportunities to interact in the L2, thereby bolstering host communication competence and overall adjustment. Therefore, those individuals who have trouble with the flow of resources over these ties should be disadvantaged in terms of the linguistic information they receive, with corresponding linguistic deficits.

A very similar take is offered by an ecological perspective, further justifying the division. It is assumed that language emerges from the semiotic activity of a group of interacting individuals. In line with Vygotskian sociocultural theory, human development occurs through mediated learning experiences in which interlocutors make joint reference to cultural artifacts and signs in order to express personal meaning and accomplish tasks using the L2. Increasingly complex thought is enabled as the individual progresses along a developmental arc in which knowledge is first co-constructed between individuals subsequently becomes internalized. Therefore, hassles which limit these mediated learning experiences, such as social isolation and constraints on time and money, should limit the subsequent language learning. The result is developmental stagnation in terms of language learning. The ability to communicate and express oneself in the L2 is pre-empted by not having the time, resources, or the speaking partners with which to engage in various learning opportunities.

The direct, negative link from L2 competence to communication difficulties, though not originally hypothesized, is justified in light of Ajzen's (2005) theory of planned behavior. Self-rated proficiency is likely a good indicator of perceived behavioral control over one's ability to communicate effectively with the host community. Actual L2 proficiency represents a skill (resource) that sojourners can use in managing L2 interactions successfully. Furthermore, the directness of the link is consistent with MacIntyre's (2007) assertion that L2 WTC does not mediate the impact of L2

confidence on L2 use in situations in which interaction is not under volitional control, as is often the case in academic contexts.

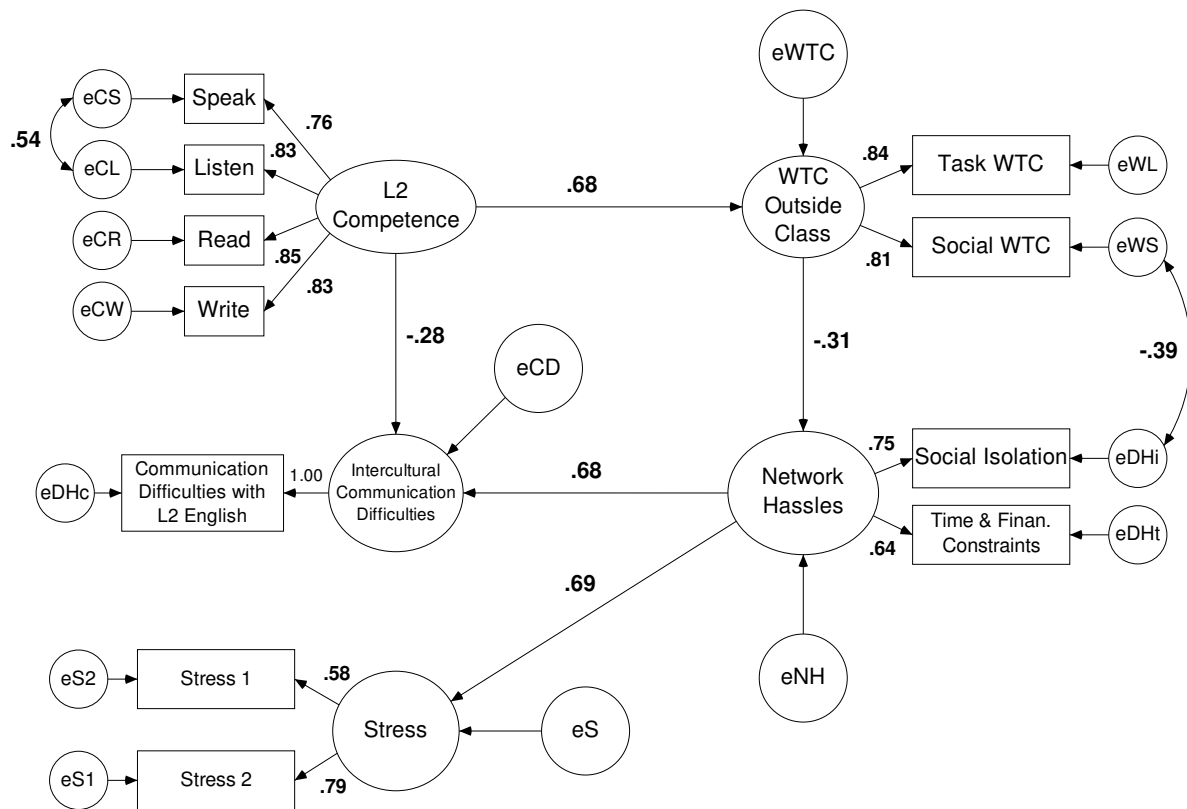

**Figure 3.3.** Divided Hassles Model.

Furthermore, this result therefore supports a central aspect of AUM; knowledge of the L2 directly fosters knowledge of the host culture, reducing uncertainty and facilitating intercultural communication. Actual knowledge of the L2 and the host culture is a personal resource that the individual can employ in meeting the demands of living and interacting in the host environment. Belief in one's L2 competence and knowledge of one's environment pre-empts initial, primary appraisal of L2 interactions as stressors; interacting in the L2 is not seen as something requiring unaccustomed effort.

The divided hassles model also suggests at least one notable non-relationship. No direct link exists from L2 WTC to intercultural communication hassles. Instead, network hassles (social isolation

and constraints) mediate a relationship between the two. Here it is necessary to keep in mind that the variable is L2 WTC *outside the classroom*. In such relatively unstructured contexts, one's immediate social network (rather than the classroom environment) represents the salient site of L2 communication and social participation outside the classroom; a sojourner's relationships are crucial to developing greater L2 competence in these contexts. As such, hassles and obstacles within this network may lead to difficulties communicating and participating in general. Future studies may wish to examine if hassles related to academic forums (such as a lack of cohesiveness) act in a parallel fashion, mediating between L2 WTC *inside* the classroom and communication difficulties.

#### **4.3.2. Limitations**

The current study has several limitations. One is the absence of several possible measures, including additional measures pertaining to frequency and quality of L2 use. An index of L2 contact would provide a more detailed picture of the relationship between L2 WTC and daily stressors. This would clarify whether those with lower daily hassles are actually exposed to the same level of potential stressors. Given the extended time span of the daily hassles items (the prior month), as well as the 4-month length-of-stay participation selection requirement however, such an effect should be partially controlled for in the current study. Nonetheless, this study ultimately shares a fundamental drawback with most other studies of trait-like L2 WTC: an assumption of equal opportunity to use the L2. Additionally, a measure of L2 anxiety would provide an affective component to L2 confidence, complementing cognitive self-evaluation. Finally, the WTC scale, though used in a prior study (MacIntyre, *et al.*, 2001), has not been tested specifically for validity.

From a methodological standpoint, despite the theorized relevance of an ecological perspective on L2 WTC, the present study does not employ an ecological methodology (e.g., Bronfenbrenner, 1993). The generalizability of the current study could have been improved by incorporating explicit comparisons of different processes of adaptation among different contexts, at different stages of development, and among different groups of students. For example, other

cultural groups may face less cultural distance than do Chinese students, and enjoy better prospects for staying in the UK and becoming rooted in the local community.

In addition, the sample was relatively small for a study of this kind, further impacting generalizability. In terms of the structural equation models, the limited sample impinges upon the interpretation of the divided hassles model, which possesses a significant post hoc revision to the original theoretical model. Despite the theoretical justifications for these revisions, SEM is more appropriate as a confirmatory approach than as an exploratory one (Garson, 2009). As such, the data-driven aspects of the model must be interpreted with additional caution, and subjected to subsequent confirmatory analyses. Larger studies comparing various international student and immigrant groups are therefore needed.

#### **4.4. Conclusion**

In the present study, I explored the link between L2 WTC and cross-cultural adaptation in international students. L2 WTC is posited as a latent communicative tendency which pushes the sojourner to actively engage with his or her new cultural surroundings. When realized, this tendency allows the individual to confront threats and challenges, to meet his or her personal goals, and to establish a satisfactory level of basic social functioning. The main result is consistent with the hypothesized role of L2 WTC as a predictor of lessened intercultural daily hassles; sojourners who are more willing to use the L2 across social situations are less prone to the irksome daily events involved with living in a new culture. These results suggest that L2 WTC may act as the phenomenological aspect of the transactional engagement between individuals' cognitive and affective capabilities and resources, and the environmental demands that they face on a daily basis.

However, data-driven results also indicate the importance of focusing in particular on the role of personal resources and social support in the emergence of communicative skills and the ability to express oneself in the L2. While the impact of some resources and support, such as time

and friendship, is not surprising, the possible role of material resources in language learning is intriguing, and potentially very important. Given its potential relevance to the way in which universities and agencies support language learners, such as international students and immigrants, further research on the role of material resources in mediated learning experiences is merited.

In all, the results indicate that the L2 WTC model might be fruitfully integrated with communication models of cross-cultural adaptation. Out of these models comes a general framework that regards communication as the transactional interface between a stranger's developing, latent, internal communicative system, and the emergent, realized communication system as witnessed within the larger host community. Essential to any comprehensive, transactional theory of cross-cultural adaptation is a direct account of the stranger's evolving set of affordances, or ecological niche, which encapsulates the individual's access and role within the larger community.

Indeed, the idea of managing one's environment to improve social functioning highlights a crucial difference between the L2 WTC model and the communication theories: the absence of any notion of self-reflective agency within the L2 WTC model. Inclusion of agentic concepts such as mindfulness (Langer, 1989) and identity flexibility (Kim, 1988; 2001) would help in theorizing how one's L2 WTC (and indeed the sojourner him-/herself) is both shaped by, and also creates, opportunities to participate in the host environment.

## Chapter 5

### Social network analysis and L2 WTC within a community of learners

#### 5.1. Introduction

“No man is an island.” Donne’s famous line seemingly encapsulates the central argument of the social turn in SLA. Endorsed by this perspective is the view of language as fundamentally a social construct, with learning and use seen as ultimately inseparable (e.g., Hymes, 1972; Firth & Wagner, 1997; see also Larsen-Freeman, 2007a). Van Lier (2000) effectively summarizes this perspective:

[T]he [language] learner is immersed in an environment full of potential meanings. These meanings become available gradually as the learner acts and interacts within and with this environment. Learning is... the development of increasingly effective ways of dealing with the world and its meanings. (p. 246)

This emphasis on language learning as social participation has led to a rapid expansion in sociological approaches that affirm second-language use learning as fundamentally rooted in personally meaningful social participation (see Firth & Wagner, 2007 for overview).

Of particular importance in this thesis is the emphasis on *interaction*, stemming from Firth and Wagner’s (1997) influential call for focus on language learning and use as it occurs within “interactive encounters” between individuals. The central importance of social interaction for learning lies in the rich, ever-changing tapestry of affordances for behavior that individuals provide to one another (Gibson, 1986). The opportunities, challenges, and threats they present each other – for reproduction, socialization, cooperation, competition to name just a few – fluctuate and change in accordance with other environmental conditions, producing a great deal of complexity in social



behavior. In this chapter, I therefore focus on interactions as the central ‘opportunity’ that is incorporated into both trait-like and dynamic conceptualizations of L2 WTC.

However, if no person is an island, neither are interactions. While calls for a more relational viewpoint have led to the increasingly accepted notion that individuals are both the products and producers of social relations, still wanting is a ‘fluid and complex system of social relations, activities, experiences and multiple micro- and macro-contexts in which the person is embedded, moves, and is inherently part of,’ (Ushioda, 2009, p. 220). Consequently, an atomistic perspective still persists within much of the SLA literature, though in a different form than that originally criticized as ‘individualistic.’ It is now social encounters themselves which sit largely in analytical isolation.

A focus on interactive encounters necessitates two important assumptions. First, encounters are not a seamless, unbroken string of input and output. Rather, they are fundamentally *discrete*, composed of distinct instances or events. As we will see, this concept is not new, having been expanded upon by a number of theorists who wish to delineate the “building blocks” of social context which join together to form larger (macro) structures, possessing their own emergent properties which in turn influence (micro) encounters themselves. Second, in being interactive, L2 encounters are inherently *relational*. The initiation of L2 communication is the joint realization of interlocutors’ respective communication tendencies. It can likewise be regarded as the social transaction of symbolic and material resources that facilitates adaptive personal functioning in the face of challenges and threats, no matter how large or small. This assumption is even more fundamental, reaching into the aforementioned debate as to whether the study of language should be first and foremost psychological or sociological.

However, a network approach modifies the assumptions of discreteness and relation in a crucial way. In being both discrete and relational, L2 communication is also fundamentally *interdependent*. Relations do not merely co-occur. Instead they are contingent; what happens across

one social tie can impact what happens across an adjacent tie, either at the same time or subsequently. As we will see in this chapter, the ramification of this is the emergence of system properties, such as groups, positions, roles, and so forth. Taken a step further, we can see that naturalistic communication between two individuals does not occur in a vacuum; it is also fundamentally influenced by what happens among others in the community.

In the current chapter, I first focus on the assumptions of encounters as discrete and relational. I look in particular at how these assumptions can be incorporated into a conceptualization of dispositional L2 WTC as an acquired normative guide that specifies one's willingness to initiate L2 use within various situation-types. Second, I look at how encounters may be detailed as *interdependent* using various social networks features, including centrality, cohesion, and role equivalence. In turn, these network features influence the process by which L2 WTC is learned. Finally, I apply these notions of interdependence within the core discussion network of international students studying English-for-Academic-Purposes at a British university, testing whether one's social position is associated with dispositional L2 WTC and perceived L2 competence.

### **5.1.1. Encounters as discrete and relational**

#### ***Contextual 'building blocks': Learning tasks and micromoments***

The treatment of L2 communication as inherently discrete is made perhaps most explicit within investigations of situated language learning within formal educational contexts (see Dörnyei, 2011 for review of the situated approach). Dörnyei (2002) casts language learning tasks in the L2 classroom as "building blocks" of the L2 learning process. For an observer, a focus on learning tasks reduces the complexity of the learning process down to manageable, discrete chunks of interaction. As a result, the researcher can accomplish a great deal by defining the classroom context in terms of the composition and structure of learning tasks - a relatively tractable endeavor.

Similarly, Firth and Wagner (2007) emphasize the need to take up the same discrete-event viewpoint as it pertains to L2 learning within all social contexts, formal and naturalistic:

[W]e are concerned to uncover learning as a ubiquitous social activity, as an interactional phenomenon that transcends contexts while being context dependent; as an instance of social cognition *in the wild*... specifically in relation to encounters where an L2 is in use. For although learning may or may not be a drawn-out process, it is certainly a process that takes place in the micromoments of social interaction in communities of practice. It is therefore critically important that we attempt to uncover and understand what goes on, interactionally, in such micromoments. (p. 807; emphases original)

Language learning, therefore, occurs discretely, not only within classroom tasks but within a larger, more general set of 'micromoments' that constitute various social situations encompassing both instructional and naturalistic contexts.

Despite a plethora of labels, these micro-events have taken up a prominent place within related literature on language learning and acculturation. For instance, a general theme of most theories of socialization is that it is an interactive process (Schieffelin & Ochs, 1986). Repeated interactions give rise to socially acceptable beliefs and values, as well as inculcating a range of social roles in the individual; socialization is the internalized footprint of these repeated interactions. Theorizing specifically in relation to cross-cultural adaptation, Kim (2001) offers a similar conceptualization, as covered in Chapter 3. Drawing on the stress and coping literature (Lazarus & Folkman, 1984), she holds stressful encounters with the host environment to be a crucial component of sojourners' learning process as they "draw back to leap". The adaptation process thus develops in an ongoing, cyclical fashion as the sojourner repeatedly confronts (or withdraws from) a series of stressful events associated with acculturation, and in the process learning to cope (adaptively or maladaptively).

Ultimately, these micromoments add up to larger, *emergent* wholes. In terms of learning tasks, we see classrooms, cohorts, and schools, and school districts. More generally, we see social cliques, groups, institutions, communities, and societies. In each case, the larger wholes are not fully explainable in terms of their smaller components. Instead, they take on their own unique character, exerting their own unique influence on the smaller components (e.g., Simmel, 1908/1971; Giddens, 1979).

### ***Shaping the encounter***

Studies of L2 WTC and network studies of social capital both fundamentally investigate variation in performance (see Section 2.3.5). Social capital researchers take a network approach to examine social opportunity as sites at which motivated action will contribute to different outcomes. Similarly, a number of SLA researchers emphasize the agentic character of interpersonal communication, ultimately wishing to understand how L2 performance could be enhanced within L2 learners (Dörnyei & Ottó, 1998; MacIntyre, *et al.*, 1998; MacIntyre, 2007; Ushioda, 2009). In subscribing to the idea that such change is possible, it is essential to assume that individuals are not passive perceivers of their social environment, who react mechanistically according to a rational calculus or ingrained, category-based social norms. Instead, individuals are widely considered to be active agents in co-constructing social reality (e.g., Festinger, 1954; Salancik & Pfeffer, 1978).

As discussed in Chapter 3 (see Section 3.3.1) and in keeping with the social turn in SLA, a social-constructivist perspective holds that social reality is the product of the interactions between individuals (e.g., Williams & Burden, 1997). As groups of individuals interact, they construct and maintain a subjectively shared viewpoint of the world that facilitates interactions with others who share the same understanding. In a similar vein, Bandura (2001) characterizes the ability of individuals to affect their surroundings:

... [H]uman agents operate generatively and proactively, not just reactively, to shape the character of their social systems. In these agentic transactions, people are producers as well as products of social systems. Personal agency and social structure operate interdependently. Social structures are created by human activity, and sociostructural practices, in turn, impose constraints and provide enabling resources and opportunity structures for personal development and functioning. (p. 15)

Therefore, human action is not the result of a one-and-done application of socialized, black-and-white decisions. Rather, it is an ongoing process that both shapes and is shaped by the environment. An outcome of this continual process is social conformity, with individuals becoming more similar in beliefs, attitudes, and values.

The generative character of human interactions, however, makes them difficult to analyze. Applying the notion of 'situation' or 'event' to the learner's naturalistic context is a formidable analytical task, in part because of the difficulty in representing the situation in the same way that individuals themselves do – that is, by defining social situations in terms of their phenomenologically salient aspects (Mischel & Shoda, 1995; Funder, 2006). In particular, Mischel and Shoda (1995) highlight the idiographic nature of individuals' phenomenological experience of situations, suggesting a potential endlessness of situation-types.

Funder (2006), however, more optimistically argues that subjective representations of situations have a high degree of sharedness. Humans probably perceive certain objective aspects of the social environment in a more-or-less similar fashion. In particular, he stresses two appropriate (though certainly not exhaustive) ways to approach conceptualizing the subjectively-experienced social situation: the *nature of the task*, and the *identity of the participants* (e.g., friends, acquaintances, strangers). This line of argument favors the network approach as taken in the current study, as a social network can be conceptualized as the intersection of interdependent, social

activities of a collection of individuals. Opportunity thus comes to be defined in terms of a task/activity engaged in along with certain (types of) individuals. Accordingly, as seen below, the network is defined in the current study with reference to both a loosely-defined activity – *core discussion* – and the identity of the participants in that activity – cohort-mates of various ethnolinguistic backgrounds.

### ***Encounter within disposition: The personality triad***

In order to give a more unified account of both trait-like and situational L2 WTC, it is necessary to integrate the notion of the encounter (or rather, the *type* of encounter) into that of disposition – a central problem within the study of dispositions. Long the domain of personality psychology, the notion of behavioral disposition has hinged upon the notion that humans are fundamentally invariant in their behavior, generally acting more-or-less the same across situations. Accordingly, the field has struggled with the controversy surrounding situation-to-situation variability in behavior within individuals.

For instance, despite Funder's (2006) aforementioned optimism in defining individuals' phenomenological experience in objective terms, attempts to delineate different psychological situations have not been pervasive within investigations of behavioral dispositions, especially as they have related to L2 use. In particular, the first phase of L2 motivation research was dominated by a macrostructural approach that treated all social contexts in aggregate, looking for individual differences in broad psychological tendencies, such as integrativeness and instrumentality (Dörnyei, 2011). The influential role of this approach is evident the first wave of L2 WTC research, with studies treating the concept as trait-like. However, an unfortunate consequence of the approach may have been the notion that psychological tendencies somehow exist independently of the environment. Given the difficulty in observing and defining informal social encounters, a macrostructural approach prevailed, supporting an oversocialized perspective on human action in which predicting communicative behavior could be done without much reference to the situation.

Funder (2001; 2006), however, has repeatedly called the disposition-situation dichotomy a false one, noting that an individual-differences perspective can be entirely consistent with situational variance in behavior. Indeed, he subsumes the notion of situation as an integral component of disposition. As a way of explanation, he offers the “personality triad,” consisting of person, situation, and behavior, in which any one aspect of the triad may be understood as the interaction of the other two aspects.

$$\text{Situation} = \text{Behavior} \times \text{Person} \quad (1)$$

$$\text{Person} = \text{Situation} \times \text{Behavior} \quad (2)$$

$$\text{Behavior} = \text{Person} \times \text{Situation} \quad (3)$$

Persons (dispositions), situations, and behaviors are thus tightly interwoven. Notably, formula 2 evokes Dörnyei’s (2002) view of the instructional task as the “interface between educational goals, teacher and students” (p. 139). Formula 3 suggests the original L2 WTC model itself, which holds L2 WTC as the precise moment of interaction between person and situation, all in an effort to understand the culminating behavior – L2 use.

In examining dispositions in particular (formula 2), “[a] person can be thought of... as the sum total of all of his or her behaviors in all the real and potential situations of his or her life,” (Funder, 2006, p. 31). This is best illustrated by Mischel and Shoda (1995), who regard dispositions as normative “if-then” behavioral contingencies learned by the individual that determine variable (though correlated) reactions to various social situations. In their view, individual differences are not monolithic, situation-independent tendencies to be summarized by a mean score. Rather they are “patterns of intrapersonal variability,” with a predictable set of various responses to different stimuli. For instance, an individual may be quite talkative across many situations. Nonetheless, in certain situations (e.g., at the cinema, at a funeral) he or she might be less garrulous, thereby

displaying intraindividual variance. Nonetheless, this person's reactions will likely remain correlated when compared to a wider sample of individuals.

The *if-then* approach is particularly amenable to a dispositional view of L2 WTC. Given the definition of trait-like L2 WTC as the likelihood of initiating L2 communication given the (psychologically-defined) opportunity, L2 WTC can be readily thought of as a collection of contingencies resembling "*if [Situation X] then initiate L2 communication, if [Situation Y] then do not initiate L2 communication.*" Therefore, dispositional L2 WTC can be seen as the intersection of L2 communication (behavior) and situations. One empirical difficulty comes in representing the intraindividual variability, which is usually flattened out by averaging behavioral scores across various situations. A view of dispositions as intraindividual patterns of behavioral variability therefore fundamentally roots the individual in the situations – or niche – that he/she inhabits.

### **5.1.2. Encounters as interdependent**

Given the general affirmation of language learning as occurring within discrete, relational encounters, it can now be assumed that L2 WTC is fundamentally shaped and re-shaped through one's interactions with others in the community. One's trait-like L2 WTC can therefore be regarded as a performance outcome learned from one's involvement in discrete social encounters over time. The point of emphasis is therefore not on the complex mesh of cognitions, affect, and motivations as in the original L2 WTC model (MacIntyre, *et al.*, 1998). Nor does the focus rest on motivational processes as they come in and out of play during a single interaction, as in the process model of L2 motivation (Dörnyei & Ottó, 1998). Rather, of central concern is how L2 WTC is learned through regularized patterns of actual communication that occurs, fundamentally, *between* individuals.

Furthermore, as detailed above, dispositional L2 WTC is conceived of in terms of an intraindividual pattern of behavioral variance for L2 communication (see Mischel & Shoda, 1995). In this view, dispositional L2 WTC is a multidimensional tendency to transform the latent *potential* for



communication into *actual* discrete, co-constructed instances of social exchange between self and other(s).<sup>56</sup> Conversely, situational L2 WTC is understood as the manifested (though dynamic and fluctuating) form of this disposition, emerging between two (or more) individuals who have provided each other with a situational trigger to engage in communication. It is the energetic “dance” between two partners whose respective tendencies towards communication have been switched on in unison by the situation in which they find themselves (either through co-construction or compliance), and fluctuates in accordance with the complexity of the ongoing interaction.

Understanding L2 WTC as an individually-learned performance outcome, however, requires examination of how individuals affect one another through this learning process. Required, therefore, is a wider lens on the social structure in which learning happens. Accordingly, emphasis in the current study is placed on describing the system of interdependent encounters between individuals. As noted by the Five Graces Group, an agent-based network model provides the much-needed account of “variation in exposure history (perhaps by occupying different positions in a social network structure) and the behavior that results from it” (Beckner, *et al.*, 2009, p. 12). The analytical focus therefore comes to rest in particular on the degree of opportunity for L2 exposure that is open to an individual by virtue of his/her social relations. This approach thus addresses the following: What are the different options for interaction from which one is choosing? Does one have an array of alternative conversation partners, or is one confined to just a few? Over time, what is the lasting impact of these differences on the individual? Addressing these questions requires looking at L2 communication not merely as relational, but as embedded within a network of relations in which one person’s decision subsequently impacts the choices of others.

These analytical pursuits are enabled by social network analysis’ provision of an array of *formally-defined* social entities and positions that may characterize the emergent properties of social

---

<sup>56</sup> It is multidimensional in that it is attuned to different (phenomenological) social situations, as psychologically-defined by the individual.

systems. In this section, I outline two basic sets of structural concepts derived from social relations. In the first set of constructs, intracultural (L1) relations are treated differently from cross-cultural (L2) relationships, with the latter considered potential opportunities for L2 interactions, and the former as potential constraints on L2 use. In the second set of network constructs, all relations are considered as linking the individual to various cohesive social clusters, thereby potentially subjecting them to the groups' normative constraints, albeit in potentially different ways.

### ***Interdependence of intracultural and cross-cultural alternatives***

The first set of research hypotheses come directly from the work of Clément, MacIntyre, and colleagues examining the beneficial effect of L2 contact on L2 use (e.g., Clément, 1980; MacIntyre & Charos, 1996; Clément, *et al.*, 2003). Within these studies, contact with members of other ethnolinguistic groups is regarded as promoting L2 self-confidence, with the oft-repeated finding that as the frequency and quality of L2 contact increases, so does L2 self-confidence. However, the notion of contact is left vague, with little explanation as to the underlying social structure.

The first aim of the current study is thus to conceptualize L2 contact in network terms. To do so, actors are described in terms of their *relational* profile of L1 and L2 relationships, rather than in terms of their ethnolinguistic *category*. Relational profiles are compiled in two ways. First, interpersonal contact is conceived of in terms of the individual's personal (ego-centric) network of direct ties. Second, I widen my focus to a larger set of ties, taking into account not only the pattern of *direct* ties, but patterns of indirect ties one and two steps removed. By doing this, it is possible to ascertain whether ego is embedded within a homogenous mesh of *either* L1 *or* L2 ties, or situated within a heterogeneous mixture of L1 and L2 ties. By doing so, it is possible to characterize whether one is locked into using the L1, locked into the L2, or faces competing language choices.

## **Social proximity to L2 speakers**

A straightforward hypothesis is that individuals who have already established relationships with L2 speakers are likely to continue these relationships, and thus have more opportunities to use the L2 than those individuals who lack outgroup ties. Previous, regular interactions with outgroup members breed familiarity and security, serving as the site of high situational L2 WTC, and boosting the likelihood of subsequent encounters (Kang, 2005; Cao & Philp, 2006). Thus, those individuals whose outgroup (L2) ties feature more prominently within their networks have said “yes” to initiating L2 communication across a wider proportion of their network encounters.

An important complication, however, is that proximity to L1 speakers may have an insulating effect. Given the reality that one’s time is finite (Wellman, 1988), having a disproportionate number of L1 speakers will likely hinder L2 WTC by occupying more and more of one’s time and encounters. Kim (2001) notes that while co-ethnic ties may ease initial culture shock, they are likely to impede long-term adaptation. This can be attributed to over-reliance on a narrow, relatively homogeneous group of individuals, which can provide a reinforcing echo-chamber for the sojourner’s defensive reactions against the host environment. This leads Kim to theorize that sojourners’ active involvement in intracultural (L1) ties impedes host communication competence, actual communication with host nationals, and ultimately, their long-term development and adjustment.

Access to the L2 speakers is therefore operationalized in terms of *proportions* of L2 to L1 ties. As reviewed in Chapter 3, a number of studies have conceptualized opportunities to use the L2 in terms of the proportion of L2 contact to L1 contact in various personal and public spheres. Asking participants about their contact with the L2 relative to the L1 across various social situations, MacIntyre and Charos (1996) found support for a direct effect of L2 contact on both L2 WTC and L2 self-confidence. Clément *et al.* (2003) found multiple direct and indirect effects of quantity and quality of L2 contact on L2 self-confidence and L2 WTC. The importance of these findings is the

direct positive effect that being in direct contact with L2 speakers has on both L2 WTC and L2 confidence.

*Research hypothesis 1a: Actors whose first-order networks have a higher proportion of cross-cultural (L2) ties will have higher L2 WTC.*

*Research hypothesis 1b: Actors whose first-order networks have a higher proportion of cross-cultural (L2) ties will have higher perceived L2 competence.*

### **Interdependent decisions: Role equivalence of L1 and L2 ties**

The intracultural and cross-cultural communication that occurs within the individual's immediate ties is highly likely to impact communication tendencies. The challenge lies in adequately conceptualizing this interaction. There is at least one significant disadvantage to conceptualizing L2 contact opportunities *purely* in terms of proportions of ties within the individual's personal network, as seen above: doing so entails treating one's social environment, and the choices made therein, as under the independent, isolated control of the focal individual. Neglected is the how these relationships are the product of shared intentions to interact with one another, potentially to the exclusion of others.

The alternative is therefore to treat personal networks as interlocking and interdependent by looking not only at ego's alters, but also at ego's alters' alters.<sup>57</sup> One person's communication choices have a social ripple effect, impacting not only those directly adjacent, but also individuals farther removed. By assuming that what happens across one tie impacts what happens across another, it is possible to ascertain the extent to which one is constrained in his/her communicative choices by the choices of others. This approach therefore takes into account individuals' roles in constituting each other's environment through the communicative decisions that they make.

---

<sup>57</sup> The method to be used also takes into account ego's alters' alters' alters.

This interlinking involvement among a network of individuals may be better understood through the concrete analogy of a school dance.<sup>58</sup> One relational contingency pervades this situation: one cannot dance with everyone simultaneously. While one can switch dance partners, dancing with one person entails not dancing with others at that moment. In this situation, your choice of who to dance with is highly interconnected with others' choices. Once you and a partner agree to a dance, you are otherwise occupied. Others see their own pool of potential dance partners decrease accordingly, and become incrementally more dependent on their remaining options. A social ripple effect ensues. As more and more individuals pair off for a dance, those who remain unpaired have fewer and fewer options from which to choose. Of course, this process is not likely to occur along a level social plain. Once a social hierarchy takes shape among the group of dancers, the higher-status individuals will routinely have more options in terms of who they wish to dance with, while lower status individuals have to rely on a narrower range of potential partners.

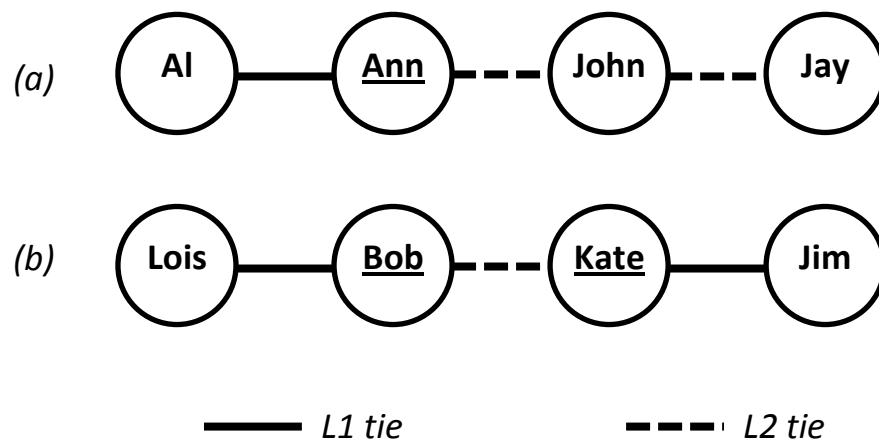

**Figure 5.1.** Two hypothetical networks of L1 and L2 ties. Circles represent actors and interior patterning represents ethnolinguistic category.

<sup>58</sup> The dance metaphor should be attributed to Shanker and King (2002), although I use the analogy here in a much simpler fashion to explain decision contingencies, rather than dynamic systems.

In a system of intracultural and cross-cultural ties, the social ripple effect takes on a slightly different pattern, but is still present. Those who have both types of tie have the regular option to choose either the L1 or L2. Meanwhile, those with only one type of tie have no option of which language to choose: those with only intracultural ties have to choose the L1, and those with only cross-cultural ties must choose the L2. The ensuing social ripple effect is illustrated by two hypothetical networks presented in Figure 5.1. Three of the actors – Ann, Bob, and Kate (underlined) – are identical to each other in terms of the proportions of L1 and L2 ties in their respective ego-networks (1 to 1). Looking at network (a) in particular, Ann’s possession of both intracultural and cross-cultural ties means that she likely splits her time between the two languages. By contrast, John, who only has cross-cultural ties, must speak the L2 at all times.<sup>59</sup> Consequently, John does not have any options in terms of which language to speak. In terms of having a reliable option for L2 interactions, this configuration works out to Ann’s advantage; all of John’s interactions are in the lingua franca, and therefore Ann will never be excluded from John’s interactions based on his use of his L1. Thus, John’s *lack* of language alternatives is a benefit for Ann.<sup>60</sup> Whenever John is around, Ann always has the option to use the L2. By contrast, John will sometimes be shut out of Ann’s interactions, as she is sometimes speaking the L1.

The situation between Bob and Kate is different. Both individuals split time between their L1 and L2 in order to maintain these relations. Their respective patterns compound with one another. Not only will there be instances when Bob is locked out of Kate’s L1 interactions, but also vice versa. In a sense, each one is competing with the other’s L1 tie.<sup>61</sup> As a result, the frequency of L2 communication between Bob and Kate is more constrained than it is between Ann and John.

---

<sup>59</sup> within the network, at least.

<sup>60</sup> In cases like John’s, the constraint is beneficial, as it forces one to choose the L2.

<sup>61</sup> It may often be more appropriate to assume that the L2 loses out to the L1, given the relative optimality and ease of the L1 system (e.g., Kim, 2001).

Therefore, while Bob and Kate can be considered to be in equivalent social positions, Ann's position is somewhat different on the basis of an indirect tie.

This system of opportunities and constraints is operationalized by a particular form of role equivalence – *regular equivalence* (see Section 2.3.2). The first step in regular equivalence leads to an initial set of four social profiles that I refer to as *immersants*, *bonders*, *bridges*, and *isolates* (see Table 5.1). However, this set is simply a starting point. Given that one's ego-network is interdependent with those of one's alters, it is necessary to further subdivide these roles into finer and finer distinctions. For example, immersants who are connected only to bridges can be differentiated from immersants who are connected only to other immersants. This distinction could be important, as the former group will have to compete with unknown languages in nearby ties, whereas the latter is surrounded only by L2 ties. This differentiation is accomplished by means of regular equivalence algorithms, as discussed below.

It is therefore generally hypothesized that in the face of similar constraints on communicative choices, role equivalent actors will experience similar interactional outcomes. In turn, these outcomes will impact one's general disposition towards communicating in the L2 (L2 WTC). What is less certain is whether individuals will attribute these outcomes to the social environment (i.e., external attribution) or to their own perceived L2 competence (i.e., internal attribution). There is evidence for both forms of attribution. In addition to findings discussed above (e.g., MacIntyre & Charos, 1996), MacIntyre et al. (2001) find that approval of L2 use by an older sibling bolstered learners' L2 WTC inside *and* outside the classroom, suggesting that role equivalent individuals have a cross-situational influence on trait-like L2 WTC. Siblings are often (visibly) exposed to the same range of situation with the same range of figures (e.g., parents, relatives, teachers, community members) therefore may serve as normative models for younger siblings.<sup>62</sup> This would

---

<sup>62</sup> However, MacIntyre et al. do not control for L2 self-confidence, leaving open the possibility that the influence of sibling support on L2 WTC is indirect, as mediated by L2 self-confidence.

correspond well with the theories of network researchers (e.g., Burt, 1987), who generally posit that role equivalent others serve as normative reference points for each other.<sup>63</sup>

*Research hypothesis 2a: Members of the same role equivalent subgroup will be more similar in L2 WTC. Immersants will have the highest L2 WTC, bridges will have the second-highest, and bonders the lowest.*

**Table 5.1.** Social profiles based on L1 and L2 ties in ego-network

	<i>L1 (ingroup) tie</i>	<i>L2 (outgroup) tie</i>
<i>Immersants</i>	No	Yes
<i>Bonders</i>	Yes	No
<i>Bridges</i>	Yes	Yes
<i>Isolates*</i>	No	No

\* Isolates are excluded from analyses for reasons outlined below.

However, role equivalence may play a particularly important role when it comes to self-evaluation of L2 competence. As stated, this system of constraints and opportunities is assumed to impact the frequency and perhaps the quality of L2 contact, and can therefore be hypothesized to influence L2 self-confidence, in accordance with Clément's (1980) social context model. As a result, role equivalent individuals are likely to be similarly influenced by their equivalent social environments. This learning process may be vicarious as well as first-hand. Facing a general lack of any objective bases for rating their L2 abilities, individuals will likely ground their self-evaluations through comparison with similar others (Festinger, 1954). Given their analogous social environments, role equivalent individuals may regard each other as appropriate social yardsticks by which to judge their own L2 ability.

<sup>63</sup> This possibility relies on the assumption that individuals can somehow detect similarities in others' normative environments. This is only likely in the particular case of structural equivalence, defined as being tied in similar ways to the exact same individuals. However, in this study, role equivalence is treated in terms of regular equivalence, which is a more general notion of equivalence (see Section 2.3.2.). As such, the current study will not differentiate vicarious from enactive learning.



*Research hypothesis 2b: Members of the same role equivalent subgroup will be more similar in perceived L2 competence. Immigrants will have the highest perceived L2 competence, bridges will have the second-highest, and borders the lowest.*

### ***Interdependence of ties in group processes***

The first set of hypotheses carry the assumption that only cross-cultural ties afford L2 use. However, this assumption might be considered appropriate only in terms of one-on-one interactions, or in monocultural group interactions. The alternative is that one may belong to groups – containing both co-ethnics and members of other ethnolinguistic groups – in which use of the L2 has been adopted as the *group norm*.

Group norms govern a wide range of behaviors within a group. Norms are the expectations of behavior and obligations that are shared by members of a group (Levine & Moreland, 1990). In order to communicate effectively and easily, individuals must arrive at accepted rules governing which language is used in which situations, as well as be able to enforce those norms on each other effectively. The social group keeps the individual ‘in check’ through its ability to continually reward compliant behavior and punish deviation from consensual norms (Coleman, 1988).

A network approach generally favors explanations of norms that focus on the ability of cohesive groups to sanction behavior. As discussed in Chapter 1, network analysts generally downplay or eschew ‘oversocialized’ explanations that emphasize individuals behaving in accordance with internalized norms associated with particular social categories. Instead, a network perspective regards group norms as locally and actively maintained, arising out of a sense of trust derived from frequent interaction and maintained by network closure (Granovetter, 1985; Coleman, 1988). This viewpoint requires explanation of how structure facilitates the repeated sharing of information regarding the attitudes and behavior of various network members, as well as the ability to enforce a consensus view about what is deemed acceptable.

L2 use is no exception. Language choice is unquestionably a highly salient aspect of any interaction that is immediately visible to those nearby. In both formal and informal contexts, use of the L2 may limit participation on the part of less-proficient learners within the group, thereby threatening face and conferring a lower status upon those individuals. Alternatively, social groups may come to view use of the L2 as unimportant or forced upon them by external requirements. As a result, groups of individuals may come to adopt norms that favor use of the L1 over the L2. Consequently, Dörnyei (1994) encourages the teaching practice of setting explicit mutually agreed-upon norms of cooperation within the L2-classroom, and highlighting to learners the ways in which actual L2 use helps one accomplish their various personal goals. These norms are facilitated by feelings of trust and security (Kang, 2005; Cao & Philp, 2006), and thus are fostered by the development of cohesive bonds among learners.

### **Group norms: Cohesive subgroups**

Cohesive subgroups predict social conformity by describing groups of individuals who are likely to share norms by virtue of their frequent interaction and interpersonal reachability. Information-sharing occurs disproportionately within dense clusters of relationships (Newman & Park, 2003). Actors within these clusters are linked together by direct and short indirect ties, providing them with “multiple redundant channels of communication” (Erickson, 1988). These channels provide a more reliable, “accurate” picture of the subgroup’s accepted norms through constant re-visitation of who believes what and who does what, such as how members are using the L1 and L2 in certain social situations, allowing individual members to continuously adjust and re-adjust their attitudes and values to coincide with other members (Erickson, 1988). This dense structural configuration also helps maintain a system of reward and punishment that enforces these norms (Coleman, 1988). The rapid sharing of information within dense clusters quickly reveals to the group whether or not a member is abiding by the group’s norms, and allows members to coordinate their actions in rewarding compliant behavior, and punishing deviant behavior.

As cited in Chapter 3 (Section 3.3.3), MacIntyre et al. (2001) find that approval of L2 use by one's friends bolstered dispositional L2 WTC outside the class. They interpret this result as suggestive of the role of friend groups as a social arena for personally-meaningful L2 use. This notion is further supported by Yashima and colleagues who have found that sub-communities of language learners serve as sites of social practice in L2 English use, thereby linking learners to a wider world community concerned with global affairs and diplomacy (Yashima, 2002; Yashima, *et al.*, 2004; Yashima & Zenuk-Nishide, 2008).

More directly observing group norms in operation, Cao (2009) finds that students' situational WTC in class is dynamically conditioned by the performance of the group. Echoing Kang (2005), she reports situational WTC as often arising out a feeling of responsibility to "fill the gap" whenever others were overly quiet during class, thereby fulfilling a group norm against silence. She also reports that WTC being dampened by over-talkative students who deprived others of the opportunity to participate by seizing every opportunity to respond.

*Research hypothesis 3a: Members of the same cohesive subgroup will be more similar in in L2 WTC.*

L2 proficiency, on the other hand, is likely to be seen as an individual ability within the context of the current study, and as such it is unlikely that any socially shared notion of the group's collective L2 proficiency emerged. While they shared a goal of passing the course, passing was not a collective, interdependent outcome. Success was thus ultimately on an individual basis, as was surely known by all students. Therefore, it is unlikely that cohesive clusters arrived at a socially shared conception of their joint L2 proficiency.

*Research hypothesis 3b: Members of the same cohesive subgroup will not be more similar in perceived L2 competence.*

### **Multiple group membership: Control over information gaps**

Holding membership in multiple groups is a highly significant social position. The significance of multiple group membership lies in the degree to which one is subject to the social norms of a single group. Those who are members of a single group cannot escape the group's conventions; they are locked into the group's rituals and routines. By contrast, those who inhabit multiple groups have more choice in terms of which group norms to participate in, joining in either group's activities as they see fit. Membership in multiple and diverse groups may provide a social vantage point, giving the individual a better idea of the ways in which groups limit behavior. This perspective may allow the individual to periodically escape the L1 confines of a single homogenous group, yet still retain links to L1 speakers.

In network terms, this position is more frequently described in terms of *brokerage* – being the unique bridge between otherwise disconnected individuals (Borgatti, 2005). The opportunity to control the information gaps that exist between individuals or clusters of individuals has been one of the most enduring notions of position within network analysis, dating back to early studies of small group interactions (e.g., Bavelas, 1950; Leavitt, 1951; Shaw, 1954). Drawing on this body of work, Freeman notes that medial (brokering) individuals may exercise power by “withholding or distorting information in transition” (1979, p. 221). Such shading of information allows the medial actor to bring others more in line with their own perceptions and interests. A medial position empowers the actor to get others to behave in a way that they otherwise would not (Emerson, 1962), or simply to “get things done the way one wants them to be done,” (Salancik & Pfeffer, 1977, p. 4). Ultimately, these powerful medial individuals may serve a wider informational role:

Availability of information should affect behavior... by determining one's role in the group.

An individual who can rapidly collect information should see himself and be seen by others in a different way from an individual to whom vital information is not accessible. Such roles

should be different in the extent to which they permit independence of action, in the responsibility they entail, and in the monotony they impose. (Leavitt, 1951, p. 41)

Occupying a medial position may instantiate in that person some sort of informal social role as a host-environment expert, acting as a repository or synthesizer of important information about the host environment. Agreeable individuals may be more likely to use this information to curry favor with others, build consensus among a group, while less agreeable individuals might manipulate others out of more selfish motives. Mediality is merely a structural location which enables either behavior.

Only a bare handful of studies have explicitly addressed the potential benefits of mediation/brokerage as a remote influence on L2 performance. Rubinfeld *et al.* (2007) find that a willingness to engage in intercultural mediating behaviors predicts enhanced sociocultural functioning in the form of lessened daily hassles, though no attempt is made to delineate structural position. Furthermore, a series of studies have investigated language brokers –children of immigrant parents who not only translate, but recast and advocate on behalf of their L1-speaking parents (e.g., Tse, 1995; Buriel, *et al.*, 1998). In particular, these studies have noted a cognitive advantage among language brokers which bolsters academic performance. In the current study, however, brokerage is seen not as a background developmental factor, but an immediate social opportunity which elicits L2 use in conjunction with ingrained motives.

*Research hypothesis 4: Actors with more medial positions in the network will be higher in L2 WTC.*

### **Group leadership: Informal social status**

Another likely structural influence on an individual's L2 WTC and perceived L2 competence is their local social status (popularity). Student cohorts are particularly ripe sites in which to investigate processes of status-seeking. Leifer and Rajah (2000) note that student cohorts are included among:

...settings where the struggle for stature must begin anew. Anywhere that orderings are only partial, intense struggles can occur even in the smallest of opportunity spaces. Such settings are where there is the most to gain from interaction and where each encounter can have enormous consequences. (pp. 255-256)

The status hierarchy within a group can be defined as “the general pattern of social influence among group members,” (Levine & Moreland, 1990, p. 598). Status manifests itself through group members’ expectations of behavior, helping individuals to make assumptions about others’ behavior within interactions (Ehrman & Dörnyei, 1998).<sup>64</sup> MacIntyre *et al.* (1998) broadly refer to the role of interlocutors’ respective social status in their ability to control the interaction. Burgoon and Hubbard (2005) note that in instances of power asymmetry, the lower-status individual is expected to assume a subordinate role in the conversation. Higher-status individuals have greater speaking rights, possessing greater freedom in leading, sanctioning, and interrupting group interactions, as well as being spoken to more (Levine & Moreland, 1990).

The hypothesized relationships between L2 WTC and popularity, and perceived L2 competence and popularity, may be two-fold. First, high L2 WTC and self-perceptions of L2 competence may stem from one’s own L2 proficiency and competence as demonstrated within various tasks and activities inside and outside of the classroom. In turn, this initial reputation as a competent user of the L2 may confer a high level of status upon that individual among his/her peers.<sup>65</sup> This process may culminate in the popular individual attaining an emergent leadership role for the popular individual, cementing disproportionate participation rights within the group, and providing a prominent platform for further use of the L2 (see Ehrman & Dörnyei, 1998).

Subsequently, other group members are likely to look to popular individuals as models for

---

<sup>64</sup> Status can therefore be differentiated from power. In structural terms, directly equating power with status is erroneous (Cook, *et al.*, 1983). A popular individual may be highly constrained if his/her alters are themselves popular. A more accurate characterization of structural power is popularity among *unpopular* individuals (i.e., those who lack alternatives) (Emerson, 1962).

<sup>65</sup> This is particularly likely given the context of the study within a course on Academic English.

“appropriate” or “acceptable” behavior under conditions of uncertainty, and rely on their interpretations of ambiguities which may reflect on individuals’ performance (Pescosolido, 2002). Popular individuals may therefore be in a better position to define and control the social situation in a way that suits them, thereby gaining a sense of freedom and/or responsibility to speak the L2.

The effect of peer status on L2 WTC has only been directly investigated once, with Dörnyei and Kormos (2000) finding that a sociometric status measure resembling in-degree interacted with task motivation to predict the level of participation in an L2-participation task. Some saw the task demands as a valuable opportunity to use the L2, while others likely saw it as a valuable opportunity to get out of classwork. In either case, however, popularity provided the opportunities to exercise one’s motives freely.

*Research hypothesis 5a: More popular actors will have higher L2 WTC.*

The impact of social status may be particularly linked to efficacy beliefs. Status can bolster evaluations of ability, both by self and by others (Levine & Moreland, 1990). Reviewing the literature on children's social adjustment, Crick and Dodge (1994) note the general finding that peer status – as measured in explicitly sociometric terms – is positively related to adaptive attributions of causality for positive and negative outcomes of behavior. In particular, children and adolescents who are well-integrated into their peer groups are more likely to appraise positive outcomes as the result of ability, and negative outcomes as the result of external factors. A status-competence link is supported by Cao (2009) who reports that EAP students were more willing to speak with interlocutors who were more competent in the L2. Although she does not explicitly appeal to notions of status, Cao’s account does suggest that individuals deemed as especially competent in the L2 receive more input from peers.

*Research hypothesis 5b: More popular actors will have higher perceived L2 competence.*

### 5.1.3. Core discussion network

In the current study, I examine the *core discussion* networks of a pre-sessional English-for-Academic-Purposes (EAP) cohort of international students. Core discussion networks are broadly defined as those individuals with whom one discusses personally “important matters” (Burt, 1984; Marsden, 1987). This particular question has likely received the most attention of any single name generator,<sup>66</sup> given its notable inclusion as the sole name generator in the 1985 General Social Survey.

There are three main advantages of the ‘important matters’ question, both generally and within the context of the current study: its validity and reliability, its focus on discrete events, and its phenomenologically-defined character. First, it reliably elicits ties that are both emotionally close and interacted with frequently; these strong ties serve as a source of a great deal of social influence and normative sanctioning (Burt, 1984). Individuals’ recall of actual interaction events is fairly poor (e.g., Bernard, *et al.*, 1984; see Appendix B.4). Instead, individuals recall interactions schematically, nominating alters with whom they interact on a frequent basis, or who are especially salient in some way (Freeman & Romney, 1987; Freeman, *et al.*, 1987). As such, the ‘important matters’ question tends to be very reliable, converging well with the set of alters that individuals remember the best (Freeman & Romney, 1987).

Second, despite its reliability in eliciting emotionally close ties, the ‘important matters’ question is conceptually grounded in a discrete relational *event* – an interpersonal discussion. Such a discussion is a more-or-less outwardly observable interpersonal happening in which actual social exchange takes place. A relational event must be distinguished from the continuous mental/emotional representation that underlies what most would likely define as a ‘relationship’

---

<sup>66</sup> Within social network methodology, questions which elicit the identities of alters are referred to as *name generators*.



(e.g., familiarity, attraction, friendship, etc.).<sup>67</sup> The question thus converges well with the assumption that learning takes place within discrete micromoments.

The third advantage that is important for the current study is its felicitously broad conceptual scope. The question's wording does not define the precise nature of interaction, leaving it up to the participant to appraise what qualifies as 'important.'<sup>68</sup> The focus on 'important matters' therefore converges well the notion of situational L2 WTC as socially co-constructed, and bolstered by feelings of responsibility and excitement, as well as security (Kang, 2005). The question bypasses surveying the range of specific "superficial causes" that may impel the individual to use the L2, focusing instead on the "basic causes" of effective communication; optimal levels of certainty and emotional arousal (Gudykunst & Hammer, 1988). The assumption is therefore made that individuals interact in ways that are *personally* meaningful and important, with matters qualifying as 'important' surely differing from individual to individual.

### ***System boundary specification***

In the current study, however, I depart with convention by taking a sociocentric (whole-network) approach to the core discussion network. Prior studies using the 'important matters' question have generally taken an ego-centric approach, looking at individuals' full range of ties across various locations and contexts, with the aim of investigating the individual as the intersection of various social groups. By contrast, in looking at a bounded core discussion network, I am specifying a system boundary around a single group – an EAP student cohort – and thus looking at the group as the intersection of various individuals. Laumann et al. (1989) argue that this step of boundary specification is a key metatheoretical issue of network boundary specification has not received the due attention it requires. Failure to delineate the network correctly runs the risk of

---

<sup>67</sup> These "dyadic states" consist of perceptual states, such as cognitive relationships (i.e., familiarity with) or affective states (e.g., trust, attraction, dislike, etc.). They are continual – not in the sense that they do not vary in intensity or even existence across time, but in that there are not comprised of discrete instances.

<sup>68</sup> This is by design. Burt (1984) argues that its wording makes it applicable to a wide range of theoretical issues, thus maintaining the extensive relevance of the GSS survey to many areas of sociological investigation.

omitting key actors or relations that may skew the analysis in such a way as to render it meaningless. Without advocating for a specific approach to boundary specification, they argue for the need to go beyond the common tactic of early studies of relying on a “common-sense” characterization of a network as “a set of actors linked in some way [that] possesses an apparent ‘entitativity’ as a self-evident natural object,” (Laumann *et al.*, 1992, p. 63).

In the current study, as in most network studies, I take a *realist* approach to boundary specification, in which a network’s existence depends on its intersubjective reality (in some sense) among most or all of its network members (Laumann, Marsden, & Prensky, 1989). This approach adheres to Weber’s (1947) notion of *Verband* (corporate group) as “a social relationship which is closed or limits the admissions of outsiders by rules” (p. 145), and which the EAP cohort fits. I assume some form of recognition of the entitativity of the cohort on the part of its members, rather than investigating it directly.<sup>69</sup>

I therefore assume the students of the cohort to represent a social entity which houses the large part of their L2 English interactions so as to make the network structure of the network meaningful to L2 performance outcomes. One of the dangers of improper node exclusion/inclusion is *partial system fallacy* (Laumann *et al.*, 1989). That is, if one is investigating the assumed flow of resources, and the boundary of the network exclude an important source of that resource – even in the face of ‘self-evident entitativity’ – then the network is incomplete with respect to that flow process.<sup>70</sup> In that case, the analysis is likely to be uninformative.

#### **5.1.4. The EAP context**

The EAP course provides a second-language context within the host environment, presenting students with many formal and informal opportunities for L2 contact, both within the

---

<sup>69</sup> Laumann *et al.* (1989) argue that this is usual for network studies, and is not likely to be problematic in studying formal groups.

<sup>70</sup> An example would be trying to find a blocked pipe in a multi-story building by only looking at the pipes on a single floor. The problem may lie elsewhere.

classroom and outside (Block, 2003). Reviewing the literature on the relationship between studying abroad context on L2 acquisition, Collentine and Freed (2004) note a surprising lack of benefit to linguistic and communicative competence (beyond lexical breadth and narrative ability) in comparison to immersion contexts. However, as Yashima and Zenuk-Nishide (2008) note, much less attention has been devoted to the impact of studying abroad on nonlinguistic outcomes such as motivation and attitudes. As discussed in Chapter 1, Isabelli-Garcia's (2006) look at the social networks of study abroad students revealed that interpersonal ties serve as the sites on which motivation is enacted, and conduits of influence on intercultural attitudes. In addition, Cao (2009) found a range of situational variables impacting EAP students' situational L2 WTC, including topic of conversation, interpersonal familiarity, others' level of participation (see Section 3.3.3.).

A few studies have reported beneficial impact of immersion on a range of nonlinguistic outcomes. For instance, Baker and MacIntyre (2000) report higher levels of L2 WTC, lower L2 communication anxiety, higher self-rated communicative competence, and a higher frequency of L2-only interactions among immersion students in comparison with their non-immersion counterparts. Looking at both immersion context and study abroad, Yashima and Zenuk-Nishide (2008) find that both study-abroad students, and at-home students who participate in an "imagined international community," communicate more frequently in the L2, enjoy a higher level of L2 proficiency, and hold attitudes and interests that connect them to a wider world of L2 use.

A further salient feature of the EAP context is the *goal-orientedness* of the learner group (see Ehrman & Dörnyei, 1998). In the current study, formally-defined instrumental goals associated with passing the course were highly salient, given the temporary and relatively short-lived nature of the cohort, and the high stakes attached to passing the course. While passing the course was a common goal of the students, it was not a collective one. Success was ultimately defined in instrumental and individualistic terms; the "reward" – admission to the destination course – goes to the individual, and is more-or-less tangible. Outside of a few group projects, the goal of passing was

not fundamentally achieved through building friendships with other students. Rather it (presumably) benefited from knowledge of relevant academic conventions and standards, and accurate knowledge of one's own performance on the course in relation to peers. It was thus being in position to share in the knowledge of the group that presumably helped students to monitor their own performance on the course and regulate their academic effort accordingly.

## 5.2. Methods

### 5.2.1. Participants

Participants included students in a pre-session English-for-Academic Purposes (EAP) course at a university in central England. All were seeking entry on various undergraduate and postgraduate courses at the institution. Virtually all required successful completion of the course as a prerequisite, as they lacked the required score on an accepted standardized language test to gain automatic entry to their intended course.<sup>71</sup> Students could enter the course at one of four intakes, corresponding to the length of the course (4-, 3-, 2-, and 1-month courses). However, although all four levels took part in data collection, the study focuses on the final one-month-long cohort (n = 79), due to the completeness of the network data for this group.

Of the 79 students in the one-month cohort, 74 students agreed to participate (4 absences and 1 refusal), resulting in a network response rate of 93.7%. A further two participants were excluded due to not responding to certain scales. One participant was excluded due to their status as an isolate.<sup>72</sup> The final sample included 71 students in all: 38 from the mainland of the People's Republic of China, 3 from Hong Kong, 5 from Taiwan, 5 from South Korea, 6 from Thailand, 2 from Japan, and one each from the following countries: India, Turkey, Indonesia, Saudi Arabia, Libya,

---

<sup>71</sup> In general, the minimum required scores were IELTS 6.5 (minimum 6.0 writing); TOEFL 560 (minimum 5.0 writing); iBT 83 (minimum 24 writing).

<sup>72</sup> 'Isolate' was within the core discussion network, which serves as the focus of the analysis. See "Core discussion network".

Nigeria, Brazil, Lithuania, Romania, Bulgaria, and Norway. 51 (71.8%) were women and 20 (28.2%) were male.<sup>73</sup> The average age was 24.0 years.

Despite efforts on the questionnaire to collect detailed language profiles for all students (including dialects) a number of the Hong Kong and Taiwan students simply replied that they were speakers of 'Chinese'. In addition, the marked cultural similarities among the groups (especially in relation to the diversity of the entire course intake), language similarities between Taiwanese students and PRC students, and educational reforms in Hong Kong mandating the learning of Mandarin, made treating the three groups as separate questionable. As such, for the purposes of analysis, I deemed it most appropriate to treat all participants from Chinese-speaking countries and regions (PRC, Hong Kong, and Taiwan) as a single language group. Similarly, students from Arabic-speaking countries were treated as a single ethnolinguistic category.

### **5.2.2. Setting**

In an effort by course leaders to produce class cohesiveness, students remained in a single class that was capped at 16 members each (in one class, 15). Students were grouped according to the general subject area of their prospective course (3 for business students, 1 for art and design, 1 for miscellaneous). Each class was taught by a team of two or three teachers for the duration of the course. Class met every week day for a total of 21 hours of instruction per week, with class topics covering academic vocabulary, academic writing skills, reading, speaking and listening, and study skills. Visa requirements mandated that students maintain an overall attendance rate of 80%. This gave a reasonable level of assurance that the students who had stayed on the course had participated in class to some meaningful extent. Although no data was collected on residence, a large proportion of the students resided in on-campus university-provided accommodation during the course. Furthermore, various social outings were arranged by the school throughout the course.

---

<sup>73</sup> Among the eight nonparticipants were six from PRC, and one each from Panama and Saudi Arabia (6 males and 2 females).

Progression to the university course was assessed by means of three assignments: an extended essay researched and written on a topic related to each student's general subject area; a group presentation; and a scripted group discussion. Given the students' level of L2 English competence, these assignments represented a considerable challenge for most students, with many anecdotal reports of substantial stress.

In light of these patterns, the system boundaries of this group are likely to be highly valid. Additionally, the length of the course was relatively short (one month), the ties to members of other cohorts were few (four), and the demanding nature of the course severely limited leisure time for most students. It can therefore be safely assumed that the EAP course and the intake group in particular represented a well-bounded network which contained a large majority of students' English-language usage, beyond that of service interactions.

### **5.2.3. Instruments**

***Perceived L2 Competence Scale.*** Perceived L2 competence constitutes the cognitive self-evaluation of L2 abilities. It therefore represents the cognitive aspect of L2 Confidence (Clément & Kruidenier, 1985; see Appendix E.1.3.). Participants evaluated how well they spoke, understood, read, and wrote English, using a 5-point Likert-type rating scale ranging from 1 (not at all) to 5 (fluently). Scores were combined to reflect overall confidence in English (4 items,  $\alpha = .83$ ).

***Willingness to Communicate in the L2 (L2 WTC) Scale.*** Participants indicated the percentage (0%-100%) of time that they would choose to initiate communication in L2 English in 20 different social situations (McCroskey & Richmond, 1987; McCroskey, 1992; see Appendix E.1.2.). Eight of the situations were distractors. The remaining 12 items asked about initiating interaction in 4 situation types (small group, one-on-one, public speaking, large group) and 3 receiver types (friends, acquaintances, strangers). The one overall WTC score was highly reliable (12 items,  $\alpha = .90$ ). It is this score which is the subject of most analyses.

Furthermore, two corresponding sets of subscores are derived. The three receiver-type scores also produced good-to-excellent internal consistency [friends (4 items,  $\alpha = .73$ ), acquaintances (4 items,  $\alpha = .78$ ), strangers (4 items,  $\alpha = .86$ )]. Of four situation-type subscales, fairly low reliability scores were found in three ( $.55 < \alpha < .70$ ).<sup>74</sup> Item deletions improved reliability for two of the three, providing generally adequate reliability levels [small groups (2 items,  $\alpha = .74$ ), one-on-one (2 items,  $\alpha = .64$ ), public speaking (3 items,  $\alpha = .68$ ), large groups (3 items,  $\alpha = .77$ )].

**Motivated Strategies for Learning Questionnaire (MSLQ).** In order to assess motivated behavior towards participating in the academic environment, participants responded to the Resource Management Strategies portion of the MSLQ, indicating the degree to which they agreed with statements regarding their own academic-related behavior for the duration of the course (Pintrich & DeGroot, 1990; Pintrich, *et al.*, 1991; see Appendix E.3.). Inclusion of this scale was intended to assess motivated coping strategies (i.e., heuristics) relevant to meeting the demands of the academic host environment (i.e., the EAP course).

Participants responded on a 7-point scale ranging from 1 (not at all true of me) to 7 (very true of me). The wordings of items were altered from the original scales to reflect motivated behaviors with the EAP course in particular. The dimensions include time and study environment management, effort regulation, peer learning and help-seeking. Unfortunately, reliability for all four dimensions were very low ( $.44 < \alpha < .59$ ). Extensive item deletion subsequently raised only one subscale – Time and Study Environment Management – into an acceptable range (4 items,  $\alpha = .62$ ). Despite deletion of four items, the scale retained much of its original character.

As a result, only the revised Time and Study Environment Management scale is used within the analyses. Nonetheless, in retrospect, the scale's inclusion was not ideally suited for the current cohort. While help-seeking, effort regulation, and peer-learning were likely relevant activities, the

---

<sup>74</sup> Notably, in each case, deletion of the “stranger” item improved reliability, with the exception of the public speaking subscale.

items may not have adequately reflected the concrete strategic behavior undertaken. A more suitable approach would have been a scale constructed for the specific purposes of the cohort.

***Intercultural Hassles Scale.*** Similar to the hassles scale used in Chapter 3, participants indicated the degree to which a set of difficult yet common daily situations were a source of annoyance or conflict over the prior month (Kanner, *et al.*, 1981; Rubenfeld, *et al.*, 2007). Hassles ranged from academic concerns to more general communication difficulties (see Appendix E.2.2.). Changes included wording alterations, alterations to condense several items into one, and adjustments specifically reflecting the EAP course in particular. A further three items were more generally adapted from original items to further address hassles associated with linguistic and cultural differences, as well as academic hassles. Using a 5-point rating scale, participants rated the salience of each daily hassle from 1 (absence of annoyance or problems) to 5 (major source of annoyance or problems). Internal consistency was very good (9 items,  $\alpha = .78$ ).

***Network Name Generators.*** Four network name generators were asked in order to construct various networks of the cohort. In addition to the core discussion network, a network of cooperation on specific group projects, and classroom networks for liking and helping were elicited (see Appendix E.4.). However, only the core discussion network produced significant results, and given space limitations, is therefore the only network considered in this study.

#### **5.2.4. Procedure**

Data collection took place on the final day of class, after the submission of the final assignments, but prior to notification of results. Informed consent was asked of all participants. Teachers for each class administered the questionnaire. Students were briefed on the purpose of the study, the meaning and potential significance of social networks, and the reason why actual names had to be used in this study. An alternative vocabulary activity was provided for the student who did not wish to take part. Further data exclusions included a self-reported isolate (in addition to a



second isolate was absent that day), as well as two participants who did not complete several sections of the questionnaire related to L2 WTC.

Further permission was sought to see students' pre- and post-test scores on a vocabulary test taken at the start and end of the course. However, a surprisingly large number of students declined, possibly due to widespread concerns about passing the course, and/or insufficient explanation on the consent form. Furthermore, a record-keeping error at the research site led to the loss of several pre-test scores. As such, an unacceptably low number of scores were obtained. Therefore, these variables were (quite unfortunately) excluded from analysis.

Given my position as an instructor on the course (though within a different cohort), I was able to obtain basic demographic information (i.e., gender, country of origin, destination course) for all students by asking other teachers and/or based on the name of the student. This was an important step, as it permitted a number of relational variables to be calculated for neighboring participants (see section on "Missing data and symmetrization" below).

### **5.2.5. Data analysis**

#### ***Missing data and symmetrization***

Despite the high response rate, most of the network measures were calculated from a sociomatrix (core-discussion network) that was symmetrized at its maximum in order to fill in missing responses.<sup>75</sup> Symmetrization of the data means that a dyadic relationship was considered as present if at least one of the two actors observed it. A common practice within network studies, symmetrization of data allows for the computation of network positions for all 79 network members. This is crucial, as nonrespondents may nevertheless hold an important position within the network. Discussing important matters with another person therefore only represents one aspect of

---

<sup>75</sup> Symmetrizing the network at its minimum (i.e., a relation exists only if both actors agree on it) resulted in a disconnected network, meaning that global measures – such as measure of betweenness and closeness – were incalculable.

multi-faceted exchange. The other side receives something (symbolic) in return: something akin to 'having one's audience/counsel on important matters sought,' which may confer status upon the sought-after individual. The symmetrized ties thus come to denote 'involvement in the discussion of important matters'.

### ***Node-level summaries***

***Flow betweenness*** (Freeman, *et al.*, 1991). *Flow betweenness* was computed (using symmetrized data) to assess an actor's amount of control over information flow within the network. This measure is the proportion of *all* independent paths (not just the geodesic) between all pairs of nodes on which the focal node lies. Flow betweenness is the total *flow* capacity that runs through the focal node. Applied to a network of binary (unvalued) relations, flow is equivalent to the number of distinct paths between nodes. This measure is therefore very similar to *Freeman betweenness* (Freeman, 1979), except that additional, independent paths are taken into account. This modification is appropriate when studying communication networks, in which the geodesic paths are just one of several possible routes on which information may travel.

***E-I index*** (Krackhardt & Stern, 1988). The actor's amount of L2 interaction opportunities relative to L1 opportunities was computed by means of his/her ego-homophily (using symmetrized data). E-I is the number of direct outgroup ties minus the number of direct ingroup ties, divided by the total number of direct ties (Equation 4.1.1). This index captures the difference of direct connections with individuals who are similar on a characteristic in contrast to connections with unlike individuals.

***Heterogeneity*** (Blau, *Inequality and heterogeneity: A primitive theory of social structure*, 1977). Blau's heterogeneity index was included as an alternative to the E-I index. The E-I index collapses all dissimilarities into a single 'outgroup', thereby ignoring diversity among multiple outgroups. By contrast, heterogeneity captures diversity, by taking into account (i.e., squaring) the proportion of ego's first-order network occupied by each individual group. The advantage of this index in the

current study is that it differentiates between individuals who have diverse ego-networks composed of many ethnicities, and those who are embedded within a single other ethnolinguistic group, and may be excluded from that group's L1 interactions.

***In-degree*** (Wasserman & Faust, 1994; see also *prestige*). The number of alters who nominate the focal node (core discussion network) is included in order to assess local social status, or popularity. This measure is independent of ethnolinguistic membership, and assesses a general level of integration within the network. This radial measure supersedes other radial measures, such as eigenvector centrality (Bonacich, 1972) and information centrality (Stephenson & Zelen, 1989), which, in the present study, would not have provided any significant conceptual improvements on in-degree.

### ***Dyadic similarity/distance matrices***

In order to analyze the effect of subgroup membership of conformity of L2 WTC, data must be dyadic; it must take the form of matrices of inter-nodal similarities (or distance), rather than as node-level summaries. Scores for the scales for L2 WTC, perceived L2 competence, other attributes, and grouping variables (e.g., shared ethnolinguistic group/category) were converted into similarity matrices.<sup>76</sup> Therefore, all values in the models are scalar values.

***Shared group/category membership.*** For membership forms (i.e., shared ethnolinguistic group/category, shared cohesive subgroup), co-membership is represented in a binary matrix using 1 for a co-membership relation and 0 for lack of co-membership. 'Ethnolinguistic singletons' were treated as a single category. This validity of this grouping goes beyond that of a miscellaneous category, as the common language among these individuals is L2 English. Furthermore, most are from European and South American countries, and thus likely have greater cultural similarity than to other nationalities in the network.

---

<sup>76</sup> except for geodesic distance, which is left as a distance matrix with larger values meaning greater distances.

**Attribute similarity.** For all continuous scales, data are represented in the form of  $n \times n$  matrices ( $n$  = number of nodes), with each cell containing the *absolute* difference in the overall mean score between every pair of nodes. Additionally, for the L2 WTC and perceived L2 competence scales only, dyadic differences are represented as *Euclidean distances* in subscale scores, in order to account for “intra-individual patterns of behavioral variability” (Mischel & Shoda, 1995).<sup>77</sup> Given the two dimensions of subscores in the L2 WTC scale, pertaining to setting-type and receiver-type, respectively (McCroskey & Richmond, 1987), two matrices are used.

### **Cohesion**

One set of research hypotheses pertains to how individuals influence each other through flow over cohesive ties. However, cohesion can be conceptualized in different ways; either as dyadic cohesion, or as membership in a cohesive subnetwork. Both conceptualizations are included in the analysis.

**Geodesic Distance.** As noted by Friedkin (1991), one of the ways in which interpersonal influence can be indexed is by dyadic cohesion, as measured by inter-nodal distances. In analyzing the direct impact of inter-nodal distance on L2 WTC, the geodesic distance (i.e., the number of intermediaries) was used, rather than frequency decay. As such, dyadic influence is inversely measured by the geodesic distance between actors.

**K-plex.** Cohesive subgroups are first conceptualized in terms of *k-plexes*. A *k-plex* is defined as a maximal subgraph (subgroup) of size  $n$  in which every member is directly connected to at least  $n-k$  other members (Seidman & Foster, 1978; cited in Wasserman & Faust, 1994). Like other concepts (e.g., *n-clique*, *n-clan*, *n-club*), the *k-plex* is a relaxation of the overly restrictive notion of the clique. However, it avoids certain undesirable properties inherent in other subgroup formulations (Wasserman & Faust, 1994). Actors may belong to multiple, overlapping *k-plexes* simultaneously.

---

<sup>77</sup> To produce a Euclidean difference between two nodes, the differences in each individual subscore are squared and then summed. The Euclidean distance is the square root of this sum.

K-plexes are based on the notion that subgroups have a high number of direct connections. As such, it emphasizes processes that occur over many direct connections and short, indirect connections. Accordingly, Wasserman and Faust (1994) urge selection of a useful value of  $k$  so that k-plexes are both interpretable and avoid undue sparseness. 2-plexes of minimum size 3 are located using UCINET VI (Borgatti, *et al.*, 2002). The advantage of this setting is that it captures cliques of size 3 yet will not apply the restrictive definition of cliques to larger k-plexes. The possible disadvantage of this setting is that it captures a type of 2-plexes of size 3 in which two nodes are disconnected, resulting in a lack of transitivity.

**Markov clustering** (van Dongen, 2000). A relatively new procedure, Markov clustering detects clusters based on the probabilities of random walks (van Dongen, 2000). This algorithm was formulated under the assumption that two nodes within a cohesive subgroup (cluster) are linked by many very short distances in comparison to nodes in different clusters. In terms of flow processes, it is assumed that a random walk is more likely to stay within a cluster than go to a different cluster.

The algorithm partitions a network into mutually exclusive clusters based on these probabilistic walks (i.e., Markov chains). This iterative process partitions the network so that nodes connected by many random walks remain connected, and those connected by fewer random walks become disconnected. Once the algorithm reaches an equilibrium point, the result is a set of non-overlapping clusters. The algorithm can be altered through manipulation of a parameter, an increase of which will result in a larger number of clusters. The algorithm works best with symmetric networks (van Dongen, 2000). The main advantage of this clustering technique is its theoretical basis on the impact of homophily on information flow. Markov clustering is based on the assumption that informational flows disproportionately between proximal actors with highly redundant interconnections.

## Role equivalence

In the current study, role equivalence is computed specifically as regular equivalence (see Section 2.3.2; see also Appendix C). Regular equivalence itself can be computed using different methods. Algorithms of equivalence advance different notions of what role equivalence means, but this varies depending on the specific nature of the data, leading to issues with conceptual rationale. In this study, the CATREGE and REGE algorithms (Borgatti & Everett, 1992b) are used. Both require multirelational data. Two relational types are used: L1 and L2 core discussion ties (symmetrized), respectively, as indicated in the example in this chapter. The key difference between CATREGE and REGE is that the former partitions the nodes into nominal classes, while the latter weights the similarities of two nodes. Thus, REGE has the advantage of preserving the differentiations made by CATREGE, while also registering inter-nodal distances which have considerable conceptual appeal. CATREGE, meanwhile, is much easier to interpret, allowing us to better understand REGE's output.

**CATREGE.** The CATREGE algorithm initially partitions actors on the basis of respective sets of relationships (L1 tie, L2 tie). These sets correspond to the four initial classes of nodes outlined above.

***Immersants*** Individuals who only have L2 ties ( $n = 15$ ). Most of these are “ethnolinguistic singletons” - the lone representatives of their respective ethnolinguistic categories within the network. The remainder included students from categories with low representation in the cohort (Japanese, Arabic-speakers) who lacked L1 ties. Two of the 15 were excluded from subsequent analyses (see Section 5.2.1).

***Bonders*** Individuals who have only L1 ties ( $n = 25$ ). This group is composed entirely of Chinese-speakers. Four of the 25 were excluded from subsequent analyses.

***Bridges*** Individuals who have both L1 and L2 ties ( $n = 37$ ). All were included in further analyses

**Isolates** Individuals who report no direct ties whatsoever (n = 2). Both were excluded from subsequent analyses.

These classes are further subdivided, based on each node's "neighborhoods." For instance, there are some bonders who are connected only to other bonders, some who are connected only to bridges, and some who are connected to both. These distinctions form subclasses become divisions for the next iteration of CATREG. This process repeats itself until each node is placed into its own class (except for perfectly equivalent nodes).

**REGE.** REGE distinguishes nodes in a different and more complex manner. With each iteration, the algorithm repeatedly re-adjusts similarities between every pair of nodes.<sup>78</sup> The first differentiation represents the largest difference between clusters, with each successive representing finer and finer distinctions.

*Model 1.* The first REGE model incorporates two matrices: one was direct ingroup (L1) ties, while the other was direct outgroup (L2) ties. Therefore, L1 and L2 ties are treated as fundamentally different, thereby capturing the notion of trade-offs between the L1 and L2 interactions.

*Model 2.* REGE model 2 makes an adjustment on Model 1 by using a distance transformation for the L1 ties, and leaving the L2 ties as direct ties only (see Appendix C.2.1). The purpose of this transformation is to emphasize the role of weak ties within the ingroup, but not for the outgroup.

### **Statistical analysis**

Due to the nature of network data as autocorrelated, data analysis was performed through permutation-based methods using UCINET VI (Borgatti, *et al.*, 2002; see Hanneman & Riddle, 2005, for tutorial).<sup>79</sup> Research hypotheses are tested by two different regression methods. Node-level data

---

<sup>78</sup> This continues for as many iterations as specified by the user. Three iterations has become the customary setting, yet is ultimately arbitrary (Borgatti, *et al.*, 2002). Each iteration refers to the maximum distance between nodes that is assumed to carry influence, so more iterations should not necessarily be an advantage.

<sup>79</sup> See Chapter 2 for a review of these methods.

are analyzed using standard OLS regression based on 30,000 random permutations (see Appendix D.1.). Dyadic data are examined using Multiple Regression Quadratic Assignment Procedure based on 10,000 permutations (see Appendix D.2.).

The presence of homophily is examined using a similar ANOVA-type model (10,000 permutations) to test for departure from randomness in tie patterns (see Appendix D.3.). The specific model allows rates of homophily to vary from group to group. This is appropriate given the relative heterogeneity of the ethnolinguistic singleton group, and possible differences in cultural norms regarding forming outgroup ties.

The presence of clustering is assessed by means of two blockmodeling techniques which attempt to fit the network structure to a core-periphery structure, and one composed of multiple factions (see Appendix D.3.). The latter algorithm is to be run twice, once using 5 factions (the number of classroom groups in the cohort) and 9 factions (the number of clusters as identified by the Markov clustering algorithm (van Dongen, 2000) discussed above)



### 5.3. Results

**Table 5.2.** Summary of research hypotheses and associated analyses.

	<i>Description</i>	<i>Test used</i>
<b>Clustering</b>	Individuals will clump into several small dense clusters, instead of a single dense core.	ANOVA-type models
<b>Homophily</b>	Individuals will group with ethnolinguistic ingroup members more than with outgroup members	
<b>Role Equiv.</b>	REGE and CATREGE will produce similar role-sets, both approximating the bonder-bridge-immersant trichotomy.	REGE; CATREGE; QAP
<b>Research Hypotheses</b>		
<b>1a</b>	Social proximity to L2 speakers will predict higher L2 WTC.	Node-level regression
<b>1b</b>	Social proximity to L2 speakers will predict higher perceived L2 competence.	
<b>2a</b>	Role equivalent individuals will have similar L2 WTC.	QAP
<b>2b</b>	Role equivalent individuals will have similar perceived L2 competence.	
<b>3a</b>	Members of cohesive subgroups will have similar L2 WTC.	
<b>3b</b>	Members of cohesive subgroups will have similar perceived L2 competence.	
<b>4</b>	Information gap control will predict higher L2 WTC.	Node-level regression
<b>5a</b>	Social status will predict higher L2 WTC.	
<b>5b</b>	Social status will predict higher perceived L2 competence.	

#### 5.3.1. Descriptive statistics

##### *Node-level variables*

The correlation table (Table 5.5) provides initial indications of relationships both expected from the L2 WTC model, and those pertaining to the research hypotheses. An important initial observation is that the Chinese group was an outright majority of this network. Additionally, both E-I index and heterogeneity measures are correlated with group membership, indicating a confound with baseline homophily. It is therefore not possible to fully disentangle ethnolinguistic background, group size, and baseline homophily. In the regression models, Chinese ethnicity will be used as a dummy variable. However, this dummy variable must simultaneously be interpreted as a dummy variable for being a member of the ethnolinguistic majority (within the EAP course).

**Table 5.3.** Means and standard deviations for attributes and network measures.

<i>Attribute measures</i>			
M (SD)			
<u>L2 WTC</u>	<u>Perceived L2 competence</u>	<u>Time &amp; Study Environment Mgt</u>	<u>Intercultural Hassles</u>
65.04 (18.46)	4.63 (0.74)	5.77 (0.83)	2.61 (0.62)
<i>Network measures</i>			
M (SD)			
Minimum : Maximum			
<u>Flow Betweenness<sup>k</sup></u>	<u>E-I</u>	<u>Heterogeneity</u>	<u>In-degree</u>
2.14 (3.09)	-0.213 (0.73)	.355 (.276)	3.04 (1.95)
0 : 14.57	-1 : 1	0 : .833	1 : 10

<sup>k</sup> Normed by dividing by maximum possible score

### ***Dyadic variables***

Turning to the results of dyadic analyses, QAP correlations among variables are presented in Table 5.6. One important result is the non-equivalence between conventional node-level correlation and QAP correlation; the QAP correlations are not equivalent to the corresponding Pearson product moments correlations found in Table 5.5. In most cases, the correlations are lower (for example, between L2 WTC and perceived L2 competence). This discrepancy is due to QAP summarizing scores as paired comparisons rather than as a single sample mean. It may also be due to skewed distributions for some variables, especially flow betweenness (see Table 5.4).

**Table 5.4.** Skew and kurtosis for variable dyadic similarity matrices

<b><i>Dyadic variable (absolute differences)</i></b>	<b><i>Skew</i></b>	<b><i>Kurtosis</i></b>
L2 WTC similarities	-.792	-.118
Perceived L2 competence similarities	-1.344	-1.886
Time & Study Environment Mgt. similarities	-1.038	-1.102
Intercultural Hassles similarities	.592	.878
Flow Betweenness similarities	-1.649	-1.933

**Table 5.5.** Intervariable Node-level Correlations

	L2 WTC	L2 SRP	TSEM	ICH	InDeg	FlowB	E-I	Heterog.	ChiMaj
L2 SRP	.430***								
TSEM	.186	-.050							
ICH	.006	-.459***	.068						
InDeg	.247*	.314**	.002	-.176					
FlowB	.243*	-.096	-.136	-.005	.146				
E-I	.276*	.380***	-.136	-.075	.165	-.165			
Heterog	.254	.469***	-.092	-.286*	.261*	-.041	.759***		
ChiMaj	-.366**	-.278*	.104	.004	-.350**	.134	-.800***	-.561***	
EthnSing	.437***	.602***	-.061	-.141	.038	-.141	.592***	.423***	-.499***

\*  $p < .05$ ; \*\*  $p < .01$ ; \*\*\*  $p \leq .001$ ; †  $p < .10$

Significance determined from 30,000 random permutations (UCINET VI)

*Abbreviations:* L2 SRP – Self-rated L2 proficiency; TSEM – Time & study environment management; ICH – Intercultural Hassles; InDeg – In-degree; FlowB – Flow Betweenness; E-I – E-I Index; Heterog – Heterogeneity Index; ChiMaj – Chinese Majority; EthnSing – Ethnolinguistic Singleton

**Table 5.6.** Intervariable dyadic (QAP) correlations

	1	2	3	4	5	6	7	8	9	10	11
1. L2 WTC Similar.											
2. L2 SRP Similar.	0.195 **										
3. FlowB Similar.	0.026	-0.096									
4. InDeg Similar.	0.005	0.035	0.224 *								
5. Shared k-plex	0.013	0.026	-0.052 *	-0.007							
6. Shared Markov	0.066 **	0.027	0.017	-0.020 ***	-0.653						
7. Geodesic Dist.	0.032	-0.054	0.088 †	0.008 ***	0.699	0.546 ***					
8. CATREGE	0.080 **	0.180 ***	-0.010	0.018 ***	-0.183	-0.150 ***	0.173 ***				
9. REGE Model 1	0.119 **	0.306 ***	-0.075	-0.027 ***	-0.166	-0.088 ***	0.204 ***	-0.601 ***			
10. REGE Model 2	0.186 **	0.420 ***	-0.112 *	-0.017 **	-0.066	-0.036	0.085 †	-0.474 ***	-0.801 ***		
11. WTC receiver	0.898 ***	0.155 **	0.048	-0.018	0.016	-0.057 *	-0.087 *	-0.068 *	-0.078 †	-0.158 **	
12. WTC setting	0.934 ***	0.168 **	-0.006	-0.016	-0.024	-0.056 *	-0.019	-0.100 ***	-0.155 **	-0.212 ***	0.871 ***

\*  $p < .05$ ; \*\*  $p \leq .01$ ; \*\*\*  $p \leq .001$ ; †  $p < .10$

Significance determined from 30,000 random permutations (UCINET VI)

*Abbreviations:* Similar. – Similarity; L2 SRP – Self-rated L2 proficiency; FlowB – Flow Betweenness; InDeg – In-degree; WTC receiver – L2 WTC receiver profile similarity; WTC setting – L2 WTC setting profile similarity

### 5.3.2. Homophily and clustering

In terms of homophily, the variable homophily model (Table 5.7) indicates several significant effects; for four of the six groups/categories (Chinese, Korean, Indonesian, and Ethnolinguistic Singletons), ingroup ties are significantly more common than outgroup ties. The intercept represents the baseline probability of a tie existing between any two members of different categories (3.9%). The parameter values represent the difference in probability for an ingroup tie. For instance, for Chinese participants, a tie with another Chinese participant was 5.1% more likely than a tie with an outgroup member – a significant value. For clustering, the tests for networks configuration strongly point to a clustered structure. While there is no established cut-off point for goodness of fit, the models indicate a decisively better fit for clustering models than for a core-periphery structure (Table 5.8).

**Table 5.7.** Variable homophily model

	Stand. Coeff. ( $\beta$ )
Intercept	.039
Chinese	.051**
Korean	.235***
Japanese	-.003
Indonesian	.088**
Arabic-speakers	-.007
Ethno. singletons	.106***
<i>P</i>	<.001
<i>R</i> <sup>2</sup>	.074

\**p* < .05; \*\**p* < .01; \*\*\**p* < .001

**Table 5.8.** Clustering models

	Goodness of Fit
Core-Periphery	.236
5 factions	.850
9 factions	.925

### ***Role equivalence: CATREGE and REGE output***

The CATREGE and REGE algorithms produced the tree diagram seen in Figures 5.3 and 5.4. Each branching point represents the partitioning of a general node-class into a more specific node-class. As the REGE does not produce partitions, the results (for REGE Model 1) were submitted to Johnson's hierarchical clustering (UCINET VI) in order to carry out comparisons to the CATREGE results. CATREGE was moderately correlated with both REGE model 1 ( $r = .601, p < .001$ ) and REGE model 2 ( $r = .474, p < .001$ ). REGE resembles the CATREGE results, grouping nodes into immersants, bridges, and bonders (isolates were removed). The branching within the dendrograms (Figures 5.3 & 5.4) indicates finer and finer distinctions among participants.

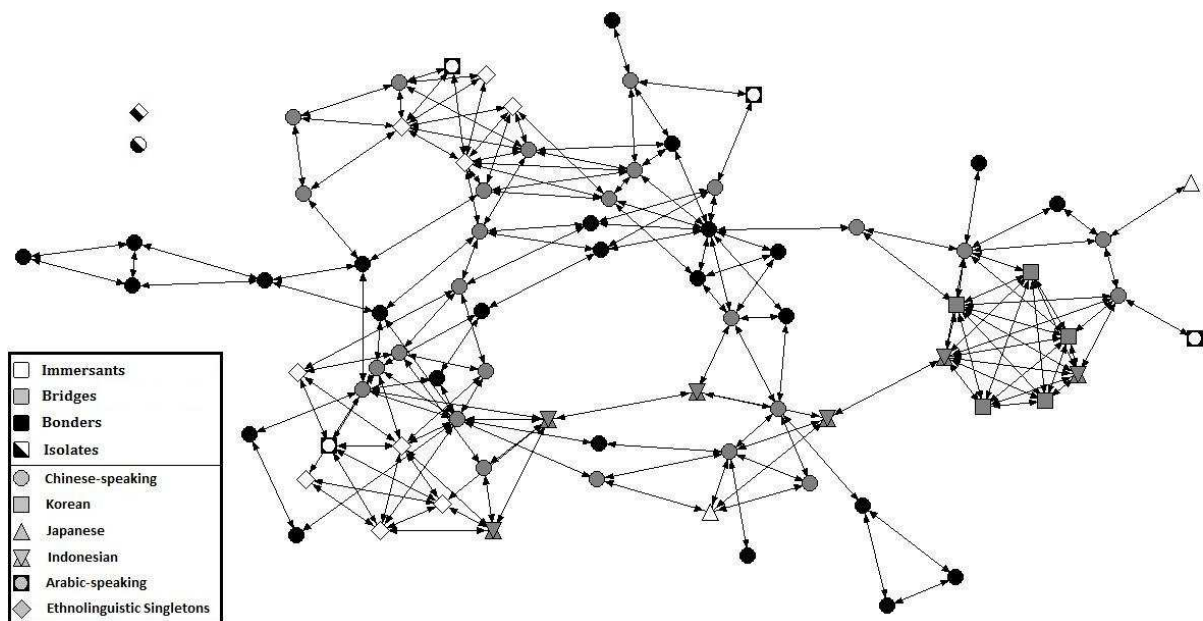

**Figure 5.2.** Core discussion network for the EAP cohort. Color represents social role (immersant, bridge, bonder, isolate), as determined by the first interaction of the CATREGE algorithm. Shape represents ethnolinguistic group.

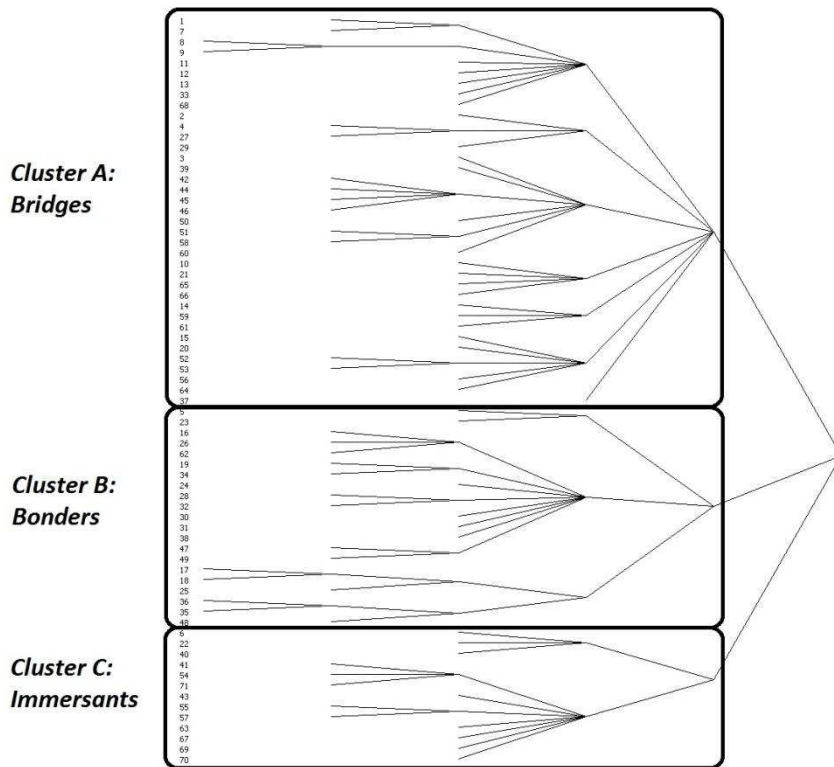

**Figure 5.3.** Tree diagram of immersant, bridge, and bonder social role clusters as computed by CATREG (UCINET VI). Finer distinctions in roles are represented by branching points moving right to left.

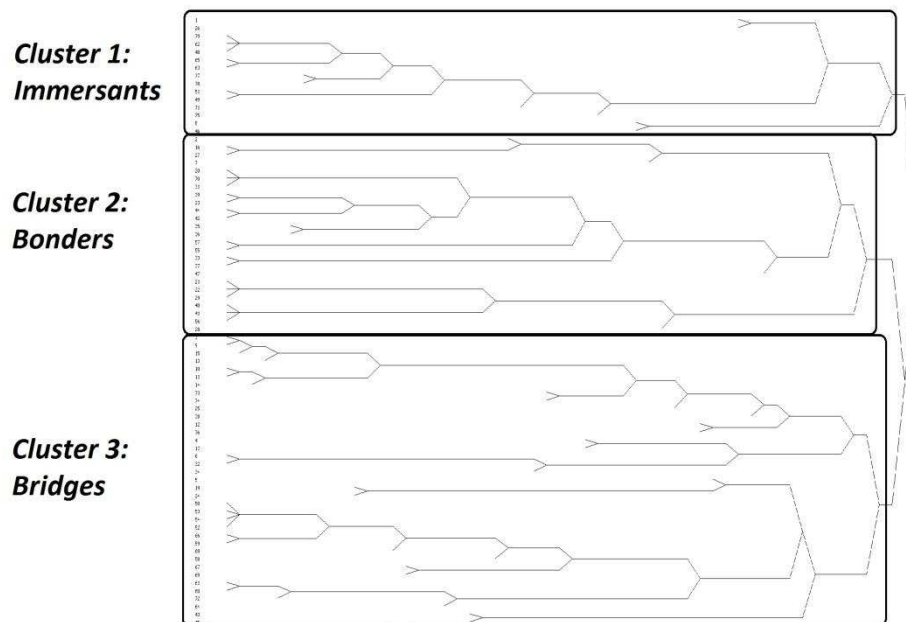

**Figure 5.4.** Tree diagram of immersant, bridge, and bonder social role clusters as computed by REGE Model 1 (UCINET VI). Finer distinctions are represented by branching points moving right to left.

### 5.3.3. Node-level results: Social proximity, status, and information gaps

As measures of social proximity (ego-homophily, heterogeneity), status (indegree) and information gaps (flow betweenness) are node-level summaries, their hypothesized relationships to L2 WTC and perceived L2 competence are tested using conventional multiple regression using permutation-based significance testing.

#### L2 WTC

**Table 5.9.** Regression models. Dependent Variable: L2 WTC

Models	Standardized Coefficients ( $\beta$ )					
	I	II	III	IV	V	VI
<u>Independent Variables</u>						
Intercept	-43.400	-18.063	-31.864	-31.682	-29.315	-30.049
<u>Attributes</u>						
Perceived L2 competence	.553***	.384*	.398*	.384†	.423†	.418†
Time & Study Environment Mgt.	.197	.224†	.281*	.280*	.270*	.280*
Intercultural Hassles	.246†	.187	.196	.197	.192	.182
<u>Grouping Variables</u>						
Chinese/Majority		-.215	-.252	-.247	-.427†	-.291†
Ethno. Singletons		.139	.170	.174	.212	.173
<u>Structural Variable</u>						
Flow Betweenness			.378**	.342**	.378**	.381**
In-Degree				.009	-.025	.006
E-I Index					-.244	
Heterogeneity						-.087
F	8.523***	6.924*	9.988**	8.429**	7.781*	7.380*
P	.001	.013	.004	.007	.025	.025
R <sup>2</sup>	.276	.348	.484	.484	.501	.488
Adjusted R <sup>2</sup>	.234	.288	.428	.419	.430	.415
$\Delta R^2$		.072	.136	.000	.027	

\*  $p < .05$ ; \*\*  $p < .01$ ; \*\*\*  $p \leq .001$ ; †  $p < .10$

Computed on 30,000 permutations (UCINET VI, Borgatti, *et al.*, 2002)



Five nested models regressing L2 WTC onto a series of node-level independent variables are presented in Table 5.9. The models were constructed on the basis of a joint theoretical model the prior theorization as outlined in the introduction (see Section 5.1.2). Unfortunately, as noted, time and study environment management was the only factor from the MSLQ to have a satisfactory level of internal consistency, it was the only usable motivation variable available. Models III through VI show a significant and robust predictor of L2 WTC to be flow betweenness, which indexes an individual's level control over the information gaps that separate clusters of individuals. Model III reveals that flow betweenness alone explains over 13% of the variance in L2 WTC on top of the previous model. Models IV and V shows that neither indegree (the number of nominations one receives), nor the E-I index (the proportion of ingroup to outgroup ties), nor the heterogeneity index (the overall ethnolinguistic diversity within one's personal network) is a significant predictor of L2 WTC.

***Perceived L2 competence***

**Table 5.10.** Regression models. Dependent Variable: self-rated L2 proficiency

Models	Standardized Coefficients ( $\beta$ )		
	I	II	III
<u>Independent Variables</u>			
Intercept	4.438	3.726	3.496
Chinese/Majority	.030	.347	.310
Ethnolinguistic Singleton	.616***	.627**	.618***
In-Degree		.375**	.322*
E-I Index		.226	
Heterogeneity			.298†
F	19.332***	15.494**	18.337**
P	<.001	.008	.002
R <sup>2</sup>	.362	.484	.526
Adjusted R <sup>2</sup>	.335	.446	.491
$\Delta R^2$		.122	.042

\* p < .05; \*\* p < .01; \*\*\* p < .001

Computed on 30,000 permutations (UCINET VI, Borgatti, *et al.* 2002)

Table 5.10 shows three nested regression models for perceived L2 competence. Model construction was once again based on research hypotheses. The models reveal that neither the E-I index nor the heterogeneity index significantly predicts perceived L2 competence beyond a confound with group size/baseline homophily. Indegree is a significant predictor of self-rated L2 proficiency, altogether explaining an additional 10% of variance in self-rated L2 proficiency.

#### **5.3.4. Dyadic results: Cohesive subgroups and role equivalence**

As measures of cohesion (k-plex, Markov clusters, distance) and role equivalence (CATREG, REGE) are scores of dyadic similarities between actors, their hypothesized relationships to dyadic similarities in L2 WTC and perceived L2 competence are tested using Quadratic Assignment Procedure Multiple Regression (MRQAP).

#### ***L2 WTC***

The starting point for constructing the dyadic regression models for L2 WTC was the variable set within the conventional regression models from the node-level analyses. However, upon converting these variables into similarity matrices and performing MRQAP, only perceived L2 competence retained its place as a significant predictor. The other independent variables – intercultural hassles, time and study environment management, and flow betweenness – did not approach significance. As such, the first two were excluded. However, given its place as a highly important predictor within the conventional regression models, flow betweenness was retained as a control in order to aid in interpretability of any subsequent results. Next, a series of dummy grouping variables representing ethnolinguistic groups more than 2 individuals was inserted. Inclusion of dummy variables therefore provides more assurance that any role of cohesion or role equivalence measures is not merely the product of their associations with the size of ethnolinguistic groups. Finally, variables of cohesion and role equivalence were successively added to the baseline to test the research hypotheses. The results are presented in a series of nested models in Table 5.11.

**Table 5.11.** MRQAP models Dependent Variable: L2 WTC Similarity (Overall mean)

	Standardized Coefficients ( $\beta$ )								
	I	II	III	IV	V	VI	VII	VIII	IX
<u>Independent Variables</u>									
Intercept	17.259	17.387	17.533	20.921	21.437	20.812	19.245	12.345	26.531
<u>Attributes</u>									
Self-rated L2 prof. Similarity	.200**	.108†	.107†	.110*	.110†	.111*	.115*	.127*	.160**
Flow Between Similarity	.045	.065	.066	.063	.057	.057	.057	.055	.051
<u>Grouping Variables</u>									
Ethno Singleton		.193**	.193**	.194**	.190**	.193**	.196**	.282***	
Chinese		.036†	.035†	.036†	.039†	.043*	.064*	.154**	
Indonesian		-.058	-.058	-.060	-.059	-.060	-.065	-.103*	-.054
Korean		-.097*	-.098*	-.090†	-.087†	-.088†	-.097*	-.129**	-.080
Arabic-Speaking		.055	.055	.056	.061	.062	.067	.077	.044
<u>Cohesion</u>									
Shared 2-plex			.017	.073*					
Shared Markov Cl.					.109**	.110**	.108**	.106**	.113**
Geo. Distance <sup>f</sup>				.081†	.091*	.089*	.083†	.082†	.098*
<u>Role Equivalence</u>									
CATREGE						-.015			
REGE (Model 1)							-.044		
REGE (Model 2)								-.198**	.107*
<i>P</i>	.002	<.001	<.001	<.001	<.001	<.001	<.001	<.001	.001
<i>R</i> <sup>2</sup>	.040	.091	.091	.095	.100	.100	.101	.107	.076
Adjusted <i>R</i> <sup>2</sup>	.040	.090	.090	.093	.099	.099	.099	.106	.075
$\Delta R^2$		.051	.000	.004	.005	.000	.001	.006	

\*  $p < .05$ ; \*\*  $p < .01$ ; \*\*\*  $p \leq .001$ ; †  $p < .10$

<sup>f</sup> Distance is *not* reverse coded. Larger values mean greater distances.

Computed on 10,000 permutations (UCINET VI)

The differences between QAP and conventional Ordinary Least Squares regression are immediately evident. Despite being derived from the node-level scores, dyadic similarity in flow

betweenness does not serve as a significant predictor of L2 WTC similarity. Furthermore, QAP produces a much lower value for R-squared than an equivalent model in conventional Ordinary Least Squares. Again, these differences may be attributed to the nonequivalent nature of QAP and conventional node-level regression, as well as the skewed distributions of some of the dyadic variables used (see Table 5.4). Nonetheless, similarity in perceived L2 competence retained a place as a significant predictor of similarity in L2 WTC.

Models III through V incorporate measures of cohesion. Again, 2-plexes and Markov clustering are both measures which delineate cohesive clusters of individuals on the basis of disproportionate density of ties within the cluster. Geodesic distance is a distance-based measure of cohesion that is identical to the notion of “(six) degrees of separation,” and refers to the shortest number of intermediary steps between two actors. On its own, shared 2-plex membership is not a significant predictor of similarity in L2 WTC. In combination with geodesic distance, however, it gains significance. Geodesic distance is a significance predictor of similarity as well, though in a positive direction; more distant individuals are more similar (after shared subgroup membership is controlled for). Incorporating the Markov clustering routine likewise produces significant results, further improving the predictive validity.

Regression models VI through VIII address incorporate the three types of role equivalence. Role equivalence assesses classes of individuals with similar patterns of intracultural and cross-cultural ties, thereby delineating who has equivalent sets of constraints on the L1 and L2 choices. The various models refer to the different algorithms used for detecting these patterns. For CATREG model and REGE Model 1, no significant results were found. For REGE model 2, a significant relationship with L2 WTC similarity was found, though in an unexpected, negative direction. The unexpected result runs contrary to the modest positive dyadic correlation between L2 WTC similarities and REGE model 2 ( $r = .186, p < .01$ ), and is likely due to strong correlations between REGE Model 2 and the two largest ethnolinguistic groupings, Chinese-speakers ( $r = .655, p < .0001$ )

and ethnolinguistic singletons ( $r = .713, p < .0001$ ), resulting in multicollinearity. Model IX confirms the suspicion of multicollinearity, with role equivalence gaining significance in the hypothesized direction when the grouping factors are omitted.

## L2 WTC as intraindividual behavioral patterns

**Table 5.12.** MRQAP models. Dependent Variable: L2 WTC similarity (Euclidean distances)

	Standardized Coefficients ( $\beta$ )	
	Receiver-type profile	Setting-type profile
<u>Independent Variables</u>		
Intercept	52.084	53.747
<u>Attributes</u>		
Perceived L2 competence similarity	.069	.068
Flow Betweenness Similarity	.057	.023
<u>Grouping Variables</u>		
Ethnolinguistic Singleton	.190 **	.207 **
Chinese	.041 †	.051 *
Indonesian	-.020	-.069
Korean	-.120 *	-.129 *
Arabic-Speaking	.032	.048
<u>Cohesion</u>		
Shared Markov Cluster	.133 ***	.082 *
Geodesic Distance <sup>f</sup>	.150 **	.059
$P$	<.001	<.001
$R^2$	.101	.100
Adjusted $R^2$	.099	.098

\*  $p < .05$ ; \*\*  $p < .01$ ; \*\*\*  $p \leq .001$ ; †  $p < .10$

<sup>f</sup> Distance is *not* reverse coded. Larger values mean greater distances.

Computed on 10,000 permutations (UCINET VI)

In order to examine dispositional L2 WTC as an intraindividual behavioral pattern in L2 communication tendencies, regression model V was re-run on the two Euclidean distance matrices

for L2 WTC. The Euclidean distance in two actors' L2 WTC scores is reached by squaring the differences in their respective L2 WTC subscores, and adding these together. The resulting matrix represents similar profiles in L2 WTC across receiver-type (friend, acquaintance, stranger) and setting type (small group, one-on-one, presentation, large group), respectively. Results are presented in Table 5.12. Similar to the two models demonstrate the same significant effect of the cohesion measures as found in the previous model, though the effect appears to be more robust for the receiver-type profile.

### ***Perceived L2 competence***

The same general procedure of model construction followed for the dyadic was used for perceived L2 competence (Table 5.13). In Model I, the differences between QAP and Ordinary Least Squares regression are once again telling. First, in-degree loses significance, yet is retained as a control. Second, being an ethnolinguistic singleton predicts conformity in perceived L2 competence, as does Chinese ethnicity. However, these differences should be considered in light of the additional grouping variables (Korean, Indonesian, Arabic-speaking) present in the model. Models II through VI indicate that shared 2-plexes, shared Markov, and geodesic distance do not predict similarity in self-evaluations of L2 ability. Meanwhile, models IV through VI demonstrate that role equivalence does predict similarity in self-rated L2 proficiency, as modeled by CATREG and both REGE models. Stronger effects are found for REGE models, with model 2 displaying the strongest effect.

### **Immigrant-bridge-bonder differences**

ANOVA results testing differences in perceived L2 competence by role equivalent class are presented in Table 5.14. The first iteration pertains to the immigrant-bridge-bonder discussed above. The second iteration makes finer distinctions within each class, differentiating on the basis of each node's neighborhood (i.e., bonders connected only to bonders versus bonders connected to bridges). Post hoc tests such as S-N-K were not conducted due to violations of assumptions of independent and normally distributed data. However, subsequent between-subject T-tests revealed

that for self-rated L2-proficiency, significant differences existed between all three groups at  $p < .05$ . ANOVA results for the second iteration of CATREG revealed a significant effect of regular equivalence subgroup on L2 self-rated proficiency [ $F(13, 57) = 4.14, p < .001$ ]. The effect size was very large (eta-squared = .486).

**Table 5.13.** MRQAP models. Dependent Variable: Perceived L2 competence similarity

	Standardized Coefficients ( $\beta$ )					
	I	II	III	IV	V	VI
<u>Independent Variables</u>						
Intercept	.557	.466	.464	.541	.869	1.18
<u>Attributes</u>						
In-Degree Similarity	.040	.044	.044	.043	.044	.038
Ethnolinguistic Singleton	.445***	.445***	.445***	.438***	.409***	.267**
Chinese	.068*	.065*	.064*	.053*	-.042	-.142**
Indonesian	.054	.056	.056	.059	.083	.134†
Korean	-.016	-.024	-.024	-.020	.018	.054
Arabic-Speaking	-.037	-.038	-.039	-.042	-.063	-.067
<u>Cohesion</u>						
Shared 2-plex		-.012				
Shared Markov Cluster			-.016	-.019	-.011	-.010
Geodesic Distance <sup>f</sup>		-.052	-.053	-.049	-.019	-.035
<u>Equivalence</u>						
CATREG				.041*		
REG (Model 1)					.184**	
REG (Model 2)						.352**
<i>P</i>	<.001	<.001	<.001	<.001	<.001	<.001
<i>R</i> <sup>2</sup>	.226	.228	.228	.230	.245	.252
Adjusted <i>R</i> <sup>2</sup>	.226	.227	.227	.229	.244	.251
$\Delta R^2$		.002	.000	.002	.015	.007

\*  $p < .05$ ; \*\*  $p < .01$ ; \*\*\*  $p \leq .001$ ; †  $p < .10$

<sup>f</sup> Distance is *not* reverse coded. Larger values mean greater distances.

Computed on 10,000 permutations (UCINET VI)

**Table 5.14.** ANOVA results for L2 WTC and perceived L2 competence by CATREG, first partition

	M (SD)				
	Immersants (n = 13)	Bridges (n = 37)	Bonders (n = 21)	F (2, 68)	Effect size <sup>a</sup>
Perceived L2 competence	5.21 (1.15)	4.63 (0.51)	4.27 (0.49)	7.61*	.183

\*  $p < .05$ ; <sup>a</sup> eta-squared

Computed on 30,000 permutations (UCINET VI; Freeman, *et al.*, 2002)

## 5.4. Discussion

The overall aim of the current study was to test whether structural notions of opportunity and constraint, as described through various social network features, bear any relation to dispositional L2 WTC and perceived L2 competence. Overall, support for the array of research hypotheses is partial, though extensive. Offered is a parsimonious pattern of results that suggests the respective usefulness of a positional (architecture-based) approach to the study of perceived L2 competence, and a relational (flow-based) approach to the study of L2 WTC.

The first set of research hypotheses re-examines the commonly-found effects of L2 contact on L2 WTC and perceived L2 competence, using network measures of social proximity, status, and information gaps which treat intracultural (L1) and cross-cultural (L2) ties separately. In all, the results indicate that perceived L2 competence is best predicted using a positional (architectural) approach, looking at individuals' patterns of intracultural (L1) and cross-cultural (L2) ties.

Research hypotheses 1a and 1b – that actors whose first-order networks have a higher proportion of cross-cultural (L2) ties will have higher L2 WTC, and higher perceived L2 competence – are both rejected. As seen in the node-level regressions in Table 5.9, neither the E-I index nor



heterogeneity is a significant predictor of L2 WTC. Having high L2 WTC was not related to having an ego-network disproportionately high in outgroup representation (or one high in diversity). Table 5.10 shows the same pattern for perceived L2 competence, with the two indices bearing no significant relationship with the dependent variable.

Research hypothesis 2a – that members of the same role equivalent subgroup will be more similar in L2 WTC – is also rejected. The dyadic results shown in Table 5.11 reveal that none of the models of role equivalence predicted similarity in L2 WTC scores after controlling for membership in the Chinese-speaking majority, and membership in the ethnolinguistic singleton category. There was thus no need to test the second part of the hypothesis regarding differences in L2 WTC by role equivalence class (immigrant, bridge, border). Therefore, one's pattern of intracultural and cross-cultural ties had no impact on L2 WTC.

Research hypothesis 2b – that members of the same role equivalent subgroup will be more similar in perceived L2 competence – is supported. The analyses in Table 5.13 demonstrate that all three models of role equivalence bear significant relationships to similarity in perceived L2 competence scores, with the REGE models showing stronger effects than the CATREGE model. The second part of this hypothesis – that immigrants would be highest in perceived competence, bridges next highest, and borders the lowest – is also supported. Immigrants are similarly high in perceived L2 competence, bridges similarly moderate, and borders similarly low (see Table 5.14). Relational patterns of intracultural and cross-cultural ties predict similarity in self-evaluations of L2 ability, and do so in the expected way.

The second general set of research hypotheses examines the effect of informal social groups of communication behavior within the network. No differentiation is made in intracultural (L1) versus cross-cultural (L2) ties. Cohesive subgroups of learners are hypothesized to be differentiated in terms of communication norms. Also, positions within and between these groups are

hypothesized to be related to differential levels of L2 WTC and perceived L2 competence. Overall, the findings suggest that L2 WTC is best predicted using a relational approach in which ties are conceived of as enabling and constraining the flow of person-to-person communication, regardless of type (L1 or L2).

Research hypothesis 3a – that members of the same cohesive subgroup will be more similar in L2 WTC – is supported. The two measures of cohesive subgroups, 2-plexes and Markov clustering, predict similarity in L2 WTC scores. However, these relationships only exist in combination with the effect of the distance between individuals, which bears an unexpected *positive* relationship with similarity. Meanwhile, the dyadic results in Table 5.12 lend further support to the effect of cohesion on similarity in L2 WTC profiles, measured as an intraindividual pattern of behavioral variance. In all, those in cohesive groups share similar levels of L2 WTC.

Research hypothesis 3b – that members of the same cohesive subgroup will *not* be more similar in perceived L2 competence – is supported. The dyadic results in Table 5.13 indicate that none of the cohesion measures predicted similarities in perceived L2 competence. Self-evaluation of one's own L2 ability does not appear to be directly related to the self-evaluations of group co-members.

Research hypothesis 4 – that actors with more medial positions in the network will be higher in L2 WTC – is strongly supported (see Table 5.9). Across several regression models (III – VI), flow betweenness is found to be a robust, stable, and important predictor of L2 WTC. This result supports the notion that the control over information gaps afforded by multiple group membership is predictive of L2 WTC.

Research hypothesis 5a – that more popular actors will have higher L2 WTC – is rejected. Indegree has no significant effect on L2 WTC (see Table 5.9). Research hypothesis 5b – that more popular actors will have higher perceived L2 competence – is confirmed. Indegree is a significant

predictor of self-rated L2 proficiency, altogether explaining an additional 10% of variance in self-rated L2 proficiency (see Table 5.10). The effect of local social status on L2 communication therefore appears to be mediated by L2 self-confidence.

Finally, in order to ensure the interpretability of a number of network measures, it was necessary to confirm several assumptions regarding the configuration of the network. The initial analyses on clustering and homophily confirmed several typical, though essential, configurational characteristics. First, there was a general pattern of homophily across the various ethnolinguistic groups/categories, with the number of ingroup ties exceeding the number that would be expected through random assortment (see Table 5.7). Second, the network was composed of multiple clusters, rather than a single core (see Table 5.8). Third, as seen in Figures 5.3 and 5.4, models of regular equivalence delineated three clusters of social roles generally corresponding to the immersant-bridge-bonder trichotomy. However, these clusters were further internally differentiated, reflecting how ego's social role is interdependent with the roles of others.

#### **5.4.1. Intracultural versus cross-cultural alternatives**

Ego's perceived L2 competence is enhanced by having cross-cultural (L2) alters who themselves lack intracultural (L1) alternatives to ego. Therefore, in investigating the effect of L2 opportunities on L2 self-confidence, it is important to take note of the interlocking nature of the personal networks of a community of individuals, instead of looking purely on each individual's social proximity to members of other ethnolinguistic backgrounds.

On one hand, the dual finding that proportions of intracultural (L1) to cross-cultural (L2) ties predicts neither L2 WTC nor perceived L2 competence seems to run contrary to an extensive amount of previous empirical evidence that quantity of L2 contact is associated with L2 self-confidence and L2 WTC (e.g., Clément, *et al.*, 2003). Considered in isolation, these null results are surprising, as relationships with individuals from other cultural groups should be important sites of opportunities

for L2 interaction. An immediate interpretation is therefore that the proportional measures used were simply not satisfactory indices of L2 contact. After one month, both cross-cultural and intracultural relationships reported by participants probably varied in their intensity to such an extent that the simple presence/absence of a tie became a poor unit of measurement for “contact.” Some ties were likely rich sites of contact, while others were more sporadic.

On the other hand, the positive results regarding the effects of role equivalence (i.e., those who hold similar patterns of L1 and L2 ties) on perceived L2 competence supports the expected role of L2 contact in predicting L2 self-confidence. As hypothesized, role equivalent individuals were more similar in self-evaluations of L2 ability, with the three most basic classes of role equivalent individuals (immersants, bridges, bonders) differing in the expected way. With unfettered access to L2 interactions, immersants had the highest self-ratings of L2 competence. Bridges, meanwhile, were embedded deeper within a web of intracultural ties. They rated themselves lower in competence, potentially as the result of frustrated attempts to communicate in the L2 which were crowded out by a competing structure of L1 ties. Lastly, bonders lacked strong intercultural ties altogether, and thus likely had no regular L2 interactions outside of structured classroom interactions. Their L2 interactions were likely to be sparse and irregular. These positive results are therefore a general confirmation of a central aspect of Clément’s (1980) social context model, and its integration with the L2 WTC model (Clément, *et al.*, 2003), both of which posit that within multicultural settings, L2 contact predicts L2 self-confidence.

The overall results can be interpreted that L2 contact is a series of fundamentally *discrete* relational events. Cross-cultural ties *facilitate* L2 interactions, but they do not *constitute* them. Rather, a cross-cultural relationship may be regarded as a latent option for L2 communication. Realization of this option only occurs when there is an actual choice to initiate communication in the L2 with a particular person. When situational L2 WTC has arisen out of a situated desire and

momentary confidence, the individuals involved must “cross the Rubicon” together, either in unison or with one person pulling the other across.

This shared intention to interact happens to the exclusion of other potential partners at that same moment. For the duration of the encounter, the interlocutors must make the joint decision to remain interacting, forgoing alternative conversation partners. These choices in part reflect the individual learner’s decision as to what is important to him/her: to steadfastly maintain one’s ethnic identity or to develop a new social identity mediated by the L2.

However, at least to some extent, one must engage in *competition* in making these choices, akin to finding a date to the school dance before getting left out in the cold. Numerous others are simultaneously seeking out interactions of their own in their various attempts at establishing new identities, and maintaining existing ones. Intercultural links are therefore potentially a double-edged sword; they are sites of both potential L2 success, as well as potential L2 failure. As (effective) interaction requires the cooperation of individuals, some cross-cultural interactions will inevitably fail to be sufficiently interesting or important and break down accordingly. The consequences of failed encounters likely cut deep into their sense of their own L2 proficiency, with individuals reassessing their own ability on the basis of how well an interaction went. Students may be blaming their own L2 abilities for not being able to initiate and/or sustain interactions with those who have easier, more personally meaningful intracultural (L1) options pulling them away.

The competitive element is to be emphasized in this instance, as it may explain why role equivalence/L2 contact did not predict L2 WTC directly. The students had only been in the UK for a short period of time, and probably varied considerably from person to person (and from situation to situation), and were at the very beginning of a radical adaptation process. As a whole, learners were probably far from what Clément et al. (2003) call the “postlinguistic stage of contact” – a developmental threshold at which L2 self-confidence is largely stable and ceases to infringe on

communicative choices. Instead, the impact of opportunity on L2 use was likely to be highly mediated by L2 self-confidence. Failures to attain and sustain L2 interactions likely impugned upon the learner's very identity as a competent user of L2 English, as highlighted by Kurata (2007; 2011), instead of dampening any sense of *desiring* to interact.

The particularly strong effect for the second REGE role equivalence model on perceived L2 competence indicates the importance of intracultural weak ties. Ingroup weak ties are a further set of potential L1 alternatives that pull the individual away from L2 interactions. The informational advantage of these ties is central to several highly influential network theories (Granovetter, 1973; Burt, 1992). Such ties provide important, non-redundant information that can be transmitted more quickly and efficiently in the L1. This underlines the significance of forgoing L1 alternatives; co-ethnics come ready-made to provide a rich array of recognizable and meaningful forms of support, allowing the individual to quickly derive support all sorts of co-ethnic relationships. Conversely, cross-cultural ties may be more opaque, requiring engagement and persistence to decode their personal value and importance.

The finding that informal social status predicts higher perceived L2 competence can be interpreted in two potentially complementary ways. First, status hierarchy may be established (quickly) through interpersonal evaluations of task competence. Given the focus of the course on academic English, L2 proficiency was a particular salient skill. Highly proficient students were therefore more attractive, and more likely to achieve higher status. Subsequently, status may have played a buffering role for their sense of self-efficacy. Higher-status individual may have been more inclined to attribute communicative successes to their own L2 abilities, and failures to the linguistic deficiencies of others.

#### **5.4.2. Position in relation to groups**

The finding that the network exhibits “typical” patterns of clustering and homophily affirms the assumption that the network is comprised of multiple pockets of similar individuals who are capable of enforcing group norms. With this assumption in place, it is possible to investigate one’s involvement in the norms of these subgroups. Overall, the results are clear-cut; one’s position in relation to norm-enforcing clusters affects the degree to which one’s choice of the L2 is under volitional control, as reflected in their dispositional L2 WTC.

The finding that L2 WTC is more similar between members of the same cohesive cluster confirms various accounts of the link between L2 WTC and group norms, including Yashima and Zenuk-Nishide’s (2008) learning community-based explanation, MacIntyre et al.’s (2001) social support-based explanation, and Clément et al.’s (2003) norm-based explanation. Without agreed-upon routines regarding which language to use and when to use it, the group will be unable to function effectively. In response, over repeated encounters, regular communicative routines build up between frequently-interacting individuals. Through this process, subgroup members come to a keen understanding of what is considered to be acceptable behavior. Norms emerge which prescribe how much one may speak, and in which language. The relative enclosure and density of the cohesive subgroup underpins the group’s ability to reward and punish on the basis of these norms. Those who deviate from the accepted norm are prone to exclusion from interaction within the cluster, and likely pushed to the margins, or into other groups. Conforming to group norms may entail speaking in a way that does not necessarily reflect one’s level of L2 self-confidence, and therefore bears a direct relationship with L2 WTC.

Between cohesive clusters exist information gaps, or what Burt (1992) refers to as ‘structural holes.’ Being positioned along the relatively sparse paths that cross these gaps is a strong, robust predictor of L2 WTC. These medial positions afford actors frequent exposure to the information that flows between clusters. Exactly what constitutes this information is not examined within this study.

However, it is possible to speculate that such information keeps medial individuals generally “in tune” with what is important to members of the network, and may include information important to social comparison of L2 abilities, as well as cultural information important to passing the EAP course, and coping with the overall intercultural adaptation process. Medial individuals’ enhanced access to what others deemed personally important may also mean that they make more effective L2 communication decisions. They are better able to make effective choices regarding what is interesting, exciting, or otherwise relevant to network members as a whole.

The multiple group membership possessed by medial individuals also means that they can escape the limits of a single group. A medial position means that one is adjacent to more than one social group. Consequently, when they encounter situations in which use of the L1 is normatively entrenched, they have the option to escape the group and seek out L2 opportunities elsewhere. This lack of constraint is inherent to the notion of bridging social capital, in which one’s performance is heightened by advantaged access to information and the inability of others to punish behavior that deviates from group norms. The downside of such constraint may be rejection by a group, as well as potential intrapsychic tension over having to accommodate multiple sets of standards. As a result, these individuals may be more adept at sympathizing with individuals from other cultures, recognizing the difficulties inherent in trying to satisfy the competing expectations and obligations of the multiple social groups to which they belong. This multiple group membership may lead to balanced self-categorizations in which the medial individual seeks to remain “above the fray” within instances of intergroup tension. This may lead to attempts at intergroup mediation, leading to more effective communication and higher L2 WTC.

However, the effect of cohesive subgroups on conformity on L2 WTC comes with an important qualification. After controlling for subgroup co-membership, an initially unexpected *positive* relationship between interpersonal geodesic distance and L2 WTC was found. This suggests that just beyond the boundaries of the subgroup, closer actors are *less* similar in L2 WTC. While not



initially hypothesized, the most likely interpretation of these results is that they are entirely consistent with the overall results for medial positions. Highly medial individuals are necessarily “between” many other actors. Accordingly, the cohesion results above describe how individuals within one’s own cluster as well as those embedded within far-away other clusters are likely to be similar in L2 WTC. In-between are mediators: highly communicative individuals who serve as gates between groups.

In conjunction with the node-level results, individuals embedded within clusters are more likely to be similarly *low* in L2 WTC; while some clusters could be flourishing sites of L2 use, for the most part, they are sites of L1 use. The pattern of a general preference for intracultural ties over cross-cultural ties (homophily) suggests that co-ethnics are linking up and likely making the interdependent choice *not* to use the L2. It is therefore those individuals who connect groups together who benefit the most.

This general interpretation largely coincides with Burt’s (1992) notion of structural holes. Individuals tend to perform better as a result of a disproportionate flow of information through their network position. The information gap is a site for the co-construction L2 WTC, with both the information-seeker and the information-giver potentially displaying high levels of communicative activity in order to facilitate a valuable exchange. One side, the information-receiver is the recipient of important information from other groups. One other side, the information-giver receives recognition of the importance of his/her role. To both, the exchange is an opportunity for L2 interaction.

This pattern of L2 WTC similarity within cohesive subgroup holds when L2 WTC is conceptualized as an intraindividual pattern of behavioral variance, especially when situation is defined in terms of interpersonal familiarity. One’s dispositional L2 WTC increases as his/her interpersonal encounters with friends, acquaintances and strangers become normatively associated

with use of the L2. The value of these conventions lies in their predictability; they reduce uncertainty over which language to use, thereby providing situation-specific behavioral scripts that make the decision-making process cognitively economical.

The significant effect of time and study environment management – a motivated strategy for learning – is consistent with the notion that individuals apply meta-cognitive self-regulatory strategies required for commitment to L2/academic opportunities in the face of non-L2 alternatives. Together with the findings from Chapter 4, it further reinforces the idea that L2 WTC is an important component of a problem-focused coping strategy to meeting the challenges and threats posed by the new surroundings. In the current study, students face the need to re-calibrate aspects of their adaptive toolkit to their new (L2) environment, in which the overriding ‘problem’ facing all students is passing the course. Carefully and conscientiously regulating one’s time and study environment is likely to be an important part of a broader set of self-regulatory strategies that help an individual in surmounting this challenge. Individuals use such strategies as a way of actively constructing situational regularities that are conducive to meeting the pervasive goal of passing.

### **5.4.3. Limitations**

There were a number of limitations of the study. First and foremost, the network approach, despite its level of detail, still excluded major components of the social environment. In particular, its cross-sectional design did not allow for investigations of dynamic changes in relationships over time. Therefore, the complex issue of the direction of causation between behavior and structure was not addressable in the current study. Furthermore, focus remained exclusively on interactions between students. Interactions with other potentially important figures, such as teachers, students in other cohorts, and other members of the host community, were excluded, for both practical reasons, and in order to delineate a tractable, bounded network. Future studies would therefore benefit from longitudinal designs, as well as use of ego-centric network measures in combination with the whole-network technique used in the current study.

In terms of measures, an actual L2 use would have been useful in confirming aspects of the social context model. However, I adopt the viewpoint of MacIntyre *et al.* (1998) that the point of language learning is to foster L2 WTC. As such, leaving the program with high L2 WTC may have been the most meaningful outcome from the standpoint of effective social functioning. Second, L2 self-confidence was only assessed by means of a 'quick and dirty' cognitive self-evaluation, and lacked an affective component, precluding wider consideration of the role of emotion in interfacing with the environment. Third, the poor internal consistency of the MSLQ subscales (Pintrich & DeGroot, 1990; Pintrich, *et al.*, 1991) found in this study indicates that it was a less than ideal choice for the current sample, which was perhaps due to the heterogeneity of the cohort.

One limitation of the network measures was due to the representation of the core discussion network, which was restricted to binary, undirected ties. While use of unweighted ties produces the most reliable results, and is most appropriate with certain measures, it obscures important variations in tie strength. Additionally, the broad conceptual scope of "core discussion activity" was not further defined. Future studies would benefit greatly from a mixed methods approach which combines the computational approach used here with the qualitative case-study approach in order to examine the co-construction of personally meaningful, interdependent social activity.

The drastically different sizes of ethnolinguistic groups were problematic for network measures which differentiated between L1 and L2 ties, as cultural background was confounded with the number of potential L2 others and role equivalence class. Future studies would benefit from monocultural contexts, or from situations in which group sizes were approximately equal, allowing for easier differentiation between group size and cultural background.

The necessity of permutation testing limits the generalizability of results. An abstract population of independent and normally distributed scores was impossible to assume, as network

measures are inherently relational, and focus is on the cohort as a social entity, rather than a statistical sample. However, in seeking to replicate network results, future studies would be well advised to consider not only the identity of the individual learners, but also a range of network parameters, including network size, the similarity in proportions of student profiles, the developmental stage of the learners (i.e., newly-arrived versus settled) and the similarity of environmental demands (e.g., pre-sessional, intensive, temporary, high stakes, etc.). Nonetheless, the current study hopefully offers a number of hypotheses and potentially replicable results.

## 5.5. Summary

In the current study, dispositional L2 WTC is seen as a trait-like, though changeable, performance outcome that is shaped and re-shaped through one's involvement in discrete social encounters over time. It is regarded as a multidimensional tendency for converting the latent *potential* for communication found in one's relationships into *actual* discrete instances of social exchange between self and other(s). However, this encounter-based account of L2 WTC ultimately cannot be described in individualistic, independent terms. Instead, a network account is required to describe the learning process as occurring within a structure of regularly-reoccurring interactions among a group of learners.

The first set of findings indicates that one's self-evaluation of L2 abilities depends not only on one's own set of intracultural and cross-cultural ties, but on the ties possessed by one's immediate alters. Interactions between two individuals have a social ripple effect in which their choice to interact reduces the options open to others. One's own freedom to use the L2 is narrowed to the degree that his/her immediate cross-cultural alters are not reliant on using the L2. This system of L1 and L2 tradeoffs cut deep, down to learners' self-efficacy. Those learners embedded deep within intracultural ties have the lowest perceived L2 competence; those embedded within cross-cultural ties have the highest; and those surrounded by a mix of both types of tie had a medium-level.

Second, one's dispositional L2 WTC is directly affected by his/her positioning with respect to cohesive subgroups which are assumed to house group norms regarding use of the L2. Network members occupying the same clusters were found to have similar levels of WTC. However, the degree to which individuals serve as unique bridges between clusters is directly proportional to WTC. Individuals' ability to move between groups, it is argued, allows them to benefit from the norms of multiple groups, as well as the ability to escape their constraints. This freedom to move between groups may bestow them with a special social role as a rich source of information integrated from several sources.

In all, the results support the exhortations of theorists such as Firth and Wagner, Hymes, and others who have embraced the study of language learning and use within social encounters. However, the results of the current study suggest the importance of moving beyond purely micro-level investigations to include the larger community structure. In doing so, it is possible to supplement the prevalence of solidarity-based explanations of relational language learning with formally-definable notions of community status, competition for interaction, behavioral chains, and bridging positions in-between social groups. The potential is for a fuller account of the complexity of relations that maintain one's social identities, and the meaningfulness that underlies L2 use.

## **Chapter 6**

### **Conclusion**

The overarching purpose of the current thesis has been to investigate the relationship between the willingness to communicate in the second language (L2 WTC) and social network structure – the pattern of social relations which link individuals together. I have thus sought to investigate whether social network analysis may be effectively employed to examine the impact of social context on how the L2 is learned and used, in keeping with the central pursuit of the social psychology of language. In conceptualizing the social context in terms of network structure, ‘context’ becomes more than merely a container in which individuals move autonomously and anonymously, using the L2 independently of one another. Rather, the learning environment comes to be defined in terms of the interdependent actions of actors themselves, bound together out of a basic social need to accomplish personally meaningful aims through one another. Subsequently, this thesis has demonstrated the various ways in which individuals are interconnected and positioned structurally with respect to one another, how these interconnections and positions influence individuals’ L2 WTC, and how this willingness facilitates their adjustment to the host environment. Ultimately, the value of social network analysis for the investigation of L2 learning and use is supported, offering a first-of-its-kind network investigation of the communication tendencies within a community of L2 learners/users.

In this concluding chapter, I begin with a summarization of a social network approach to L2 learning and use, including the general themes and findings of each chapter. Next, I offer the chief implications of the approach and the associated empirical findings, followed by their principal limitations. Finally, I broadly outline directions for future research.

## 6.1. Summary

The “educational shift” in L2 motivation studies and the more general “social turn” in the field of SLA (see Larsen-Freeman, 2007a) has prompted much theoretical debate and empirical effort regarding language as fundamentally a social construct (Hymes, 1972; Firth & Wagner, 1997; 2007), and greatly expanding the array of psychological frameworks and methodological approaches by which to investigate situated language behavior (see Dörnyei, 2011 for review). With this paradigm shift came an increasing focus on actual L2 use not only as correlated with numerous individual differences, but also as situated in various overlapping social contexts, and subject to different situational pressures. Accordingly, MacIntyre et al. (1998) have advanced the *willingness to communicate in the L2* (L2 WTC) model, which integrates a variety of existing models and frameworks of L2 motivation and use into a single framework of the behavioral intention to engage in L2 communication. Conceptualized as the “readiness to enter into discourse at a particular time with a specific person or persons, using a L2” (MacIntyre, et al., 1998, p. 547), L2 WTC is regarded as the fluctuating intention to use the L2, *given the opportunity*. It is viewed as resulting from an array of individual, contextual, and situational factors that interact, either to elicit a psychological readiness to communicate, or to forestall it. Most immediately, however, as the behavioral intention to use the the L2 given the chance to do so, L2 WTC is seen as the will to use the L2 that arises out of a desire to communicate (to achieve some personally meaningful goal), coupled with the communicative self-confidence to do so.

MacIntyre et al. (1998) assert that instilling such a willingness should be the ultimate goal of any L2 instruction program. As a result, most studies of L2 WTC have sought to investigate the impact of contextual features of the language classroom, as well as of the wider social milieu. However, despite the increasing focus on the complex mesh of antecedents leading to the situated use of the L2, researchers have still been left without a “parsimonious system of valid and generalizable parameters to describe contextual characteristics” (Dörnyei, 2009a, p. 238).

Accordingly, recent interest in language in terms of dynamic systems theory has compelled theorists to drastically rethink how to conceptualize the link between the individual and the social environment. In particular, the Five Graces Group (Beckner, *et al.*, 2009) suggest the potential importance of analyzing the social network structure of a community of speakers, assuming language use to be an evolving, emergent property of the social system in which it is used.

Therefore, the first task of the thesis has been to outline a general social network approach to language learning and use. In Chapter 2, I review the general historical development of social network analysis, its current graph-theoretical character, and its applications within the general study of language behavior. Social network analysis is characterized as a “loose federation of approaches” (Burt, 1980, p. 79) underpinned by a few basic assumptions, including the social relation as the basic unit of analysis, the interdependence of actors, relationships as sites for social exchange, social ties as constraining and enabling individual action, and a general viewpoint that attributes such as gender, class, and ethnicity are more appropriately defined in relational terms, rather than as categories. These core assumptions set the stage for the construction of a social network approach to individual behavior. In formulating such an approach, however, one does not set out to replace non-network theories of individual behavior. Instead, the aim is to complement and expand network analysis through the importation of various social psychological theories, while retaining “the distinctiveness of social network emphases on patterns of relations, multiple levels of analysis, and the integration of graphical and quantitative data,” (Kilduff & Tsai, 2003, p. 64).

In seeking a balanced conceptualization of the human agent as neither under- nor oversocialized, I set forth the task of integrating social network analysis within a framework of purposeful yet constrained L2 use. L2 learners/users neither operate independently of the social context in which they live, nor do they conform completely and uncreatively to social norms assigned to the various social categories they inhabit (Granovetter, 1985). Instead, action must be understood with respect to the structure of routine social interactions in which the actor is



embedded. Indeed, as Passy (2002) emphasizes, one of the central functions of networks is to provide *opportunity* for (inter)action and innovation on cultural meanings. As a consequence, the analysis of social networks becomes a key component to capturing a systematic notion of 'opportunity' inherent in conceptualizations of L2 WTC.

In Chapter 3, I review the body of empirical and theoretical studies of L2 WTC. I cite two dichotomies inherent in the literature. The first is the evident split between the notion of L2 WTC as a trait-like disposition, versus its conceptualization as a situated, fluctuating entity that rises and falls as various person-, contextual, and situational factors converge and interact. The two can be understood as complementary. The trait-like notion can be regarded as a latent tendency to initiate communication in various situations; conversely, situational L2 WTC can be understood as its manifestation – the dynamic, ongoing realization of latent L2 WTC as it occurs between two interlocutors. In the course of this realization, an individual may come to revise his or her willingness to enter into future interactions of a given sort. Therefore, dispositional L2 WTC can be understood as the internalized tendency to communicate in the L2 which is learned through the co-construction of situational L2 WTC.

The second distinction made in Chapter 3 is between the two ways in which intention is treated: as a product of the inner workings of the human mind; or as something shared between individuals that permits them to jointly attend to some aspect of the environment. These differing treatments have resulted in two major strands within L2 WTC research: the (earlier) psychological antecedent strand, and the (later) social co-construction strand. In particular, studies in the social co-construction strand offer the greatest insights for subsequent network investigations of L2 WTC. These studies portray L2 WTC in a developmental light – as a learned disposition forged within social groups and roles (e.g., MacIntyre, *et al.*, 2001; Yashima & Zenuk-Nishide, 2008).

In Chapter 4, I address the first empirical aim of the thesis: to examine the role of L2 WTC in the cross-cultural adaptation process of sojourners. In general, I assert that the L2 WTC model may be placed alongside models of intercultural communication (Kim, 2001; Gudykunst, 2005a; 2005b) which hold communication to be the transactional interface between person and environment. In engaging directly with the environment, the individual confronts threats and challenges to meet his or her personal goals and to establish a satisfactory level of basic social functioning. By extension, culture shock can be regarded as the severe emotional arousal and cognitive uncertainty experienced by the sojourner in the midst of a drastic shift in ecological niche from home country to host environment. Upon first migrating, the sojourner may initially find his/her personal resources – including his/her level of communicative competence – to be inadequate to address the routine challenges afforded by the environment. L2 WTC can therefore be regarded as the psychological readiness to actively engage with one's new cultural surroundings in an attempt to re-establish an adaptive person-environment fit.

Therefore, I hypothesize that L2 WTC facilitates an adaptive fit within a new culture. In a cross-sectional study of Chinese-speaking international students studying at a UK university, I find L2 WTC to be predictive of cross-cultural adjustment. Structural equation modeling confirms a theoretical model in which L2 WTC predicts lessened daily hassles associated with acculturation. However, a further data-driven model indicates that L2 WTC predicts lessened daily 'network' hassles associated with limits on resources, such as social support, time, and money. In turn, these constraints predict communication hassles, such as expressing oneself in the L2. Both models indicate the important role of L2 WTC in facilitating cross-cultural adjustment; however, the latter model also suggests L2 WTC as a disposition which pushes the individual to establish a functioning support network that eases constraints faced by the sojourner. Out of the enhanced interactions, the individual comes to internalize the various cultural meanings imbued in the L2, enhancing the individual's ability to think and express oneself using the L2.

In Chapter 5, I address the final two empirical aims of the thesis: to conceptualize the opportunity for social interaction in terms of network structure, and to investigate their relationship to dispositional L2 WTC and perceived L2 competence. I examine which, if any, emergent properties of the community social structure influence trait-like L2 WTC, which is regarded as a performance outcome learned from one's involvement in discrete, interlinked social encounters over time, continually shaped and re-shaped through one's interactions with others in the community. As a research site, I look at the core-discussion network of international students studying English-for-Academic-Purposes at a UK university, defined in terms of individuals who discuss 'important matters' with one another (Burt, 1984).

I first examine learners' interdependence in terms of patterns of intracultural (L1) and cross-cultural (L2) social ties,<sup>80</sup> adhering to the assumption that intracultural ties are generally inhibitory of L2 use, while cross-cultural ties are facilitative (Kim, 2001). The patterning of ties is operationalized in two ways: as the proportion of L1 to L2 ties in one's immediate, first-order ego-network, and; as a wider system of L1 and L2 ties in which one's own L2 opportunities are enhanced as one has cross-cultural alters who lack the opportunity to use their own L1. Results demonstrate that while this system of tradeoffs is not significantly related to L2 WTC, it is related to perceived L2 competence.<sup>81</sup> These findings were interpreted as supporting Clément's original assertion that the frequency and quality of L2 contact is directly related to L2 self-confidence. Crucially, however, this contact is not indexed adequately by the learner's first-order network of social ties. Instead, one must account for the individual's embeddedness in a system of individuals making similar joint decisions to use the L2.

The second way in which I conceptualize the opportunity to use the L2 is by looking at the ways in which all ties – intracultural and cross-cultural – cohesively link learners to one another, as

---

<sup>80</sup> This approach constitutes a *positional* network approach, looking at the pattern, or 'architecture' of various tie types.

<sup>81</sup> Simple proportion of L1 to L2 ties, however, was not related to either variable.

measured in terms of centrality and cohesive subgroups.<sup>82</sup> Cohesive clusters are assumed to share social norms, and thus should use the L2 in similar ways. At the same time, central individuals who occupy highly medial positions between subgroups are hypothesized to control the flow of information between subgroups, and may be able to move between groups allowing them to benefit from the norms of multiple groups, as well as escape their constraints on L2 use. Results support the hypothesized influence of cohesion on L2 WTC, with cohesive subgroups housing similar levels of L2 WTC among group members, and medial individuals having higher L2 WTC.

These findings were interpreted as supporting the emergence of communicative norms among frequently interacting individuals. In jointly attending to personally meaningful ‘important matters,’ individuals share what is considered acceptable in terms of communication behavior. However, simultaneously, one must look beyond dyadic interactions to include the larger community structures, including formally-definable notions of community status, competition for interaction, behavioral chains, and bridging positions in-between social groups.

## **6.2. Implications**

In general, the current thesis carries a number of implications for a network approach to L2 learning and use. I discuss four of the most important: the conceptualization as the interface between person and environment, the mutual causation of structure and behavior, networks as imbued with cultural meaning, and the disparity of opportunity within the classroom.

### **6.2.1. Emergence and L2 WTC**

As Ellis (2006) points out, “[language] comprises the interactions of many players: people who want to communicate and a world to be talked about” (p. 107). However, while the field of psychology has provided a rich inventory of theories to explain the inner mental world of the

---

<sup>82</sup> This approach constitutes a *relational* network approach, looking at the way in which ties enable or constrain the ‘flow’ of material and symbolic resources (e.g., information, social support, goods, contagion, etc.).

“people who want to communicate,” including motivation, cognition, affect, and so forth, it has yet to provide a suitably sophisticated account of “a world to be talked about.” In all, a social network approach to language learning and use addresses this gap, conceptualizing the social world in terms of structures of social interactions, including cohesive subgroups, roles, and notions of centrality. In all, network analysis provides researchers with an array of essential methodological tools contributing towards Bronfenbrenner’s (1993) ultimate goal of a “differentiated conceptual framework for analyzing the developmental environment as a system of nested, interdependent, dynamic structures” (p. 4).

A developed account of this social world is needed to more fully explicate language as an emergent phenomenon, arising out a wider human system of semiotic effort in which individuals share their intentions with one another in order to achieve personally meaningful aims (e.g., van Lier, 2000; Ellis, 2006; Beckner, *et al.*, 2009). In the course of this joint social activity, individuals reproduce and reshape social realities mediated by the L2. These realities encompass various forms of cultural knowledge and ways of doing things (D’Andrade, 1981). Therefore, language is not an invariant code, but an evolving means of coordinating activity. Accordingly, L2 acquisition is the internalization of the semiotic system used to talk about the environment. The L2 learner, meanwhile, is an adaptive problem solver within this environment, using the L2 for a purpose: to overcome challenges, deal with threats, and take advantage of valuable opportunities.

From this viewpoint, L2 WTC takes its place as both the transactional interface between person and environment, and the latent disposition pushing the person towards to engage with the environment. Dispositional L2 WTC is regarded as a person’s multidimensional tendency to initiate communication with various individuals in various situations. Drawing on Bronfenbrenner’s (1993) ecological paradigm, dispositional L2 WTC can be seen as comprising various “developmentally instigative characteristics” that impact the psychological development of the individual by initiating the process of interpersonal interaction with other persons and aspects of the environment. In the

study of sojourners' cross-cultural adjustment in Chapter 4, L2 WTC is regarded as a component of problem-focused coping style that pushes the sojourner to engage directly with the host environment. Communicative skills and the ability to express oneself in the L2 are learned in the course of engaging directly with the host environment and seeking out social support from others using the L2. Conversely, situational L2 WTC can be understood as the observable manifestation of this disposition as it emerges between interlocutors *in situ*. Actual L2 use therefore occurs when a tipping point is reached converting the *potential* for L2 communication into *actual* interpersonal L2 communication. L2 WTC is the psychological readiness to actualize his or her latent knowledge of the semiotic system in a certain way with a certain person in a certain situation.

In all, the findings of the network study in Chapter 5 indicate that the emergent properties of the network help to shape the internalization of L2 WTC within the individual. One's readiness to enter into L2 discourse is influenced by emergent group norms, and the brokerage opportunities that exist between groups. Meanwhile, one's pattern of ties serves as a measure of L2 contact, with 'contact' conceived of in terms of wider systems of joint choices made within a community of speakers.

Importantly, however, investigating the emergent properties of social systems, as seen especially in Chapter 5, does not upend previous findings regarding the impact of context on L2 WTC and L2 use. Rather, it reinforces these findings. Instead of investigating the social environment in terms of how it is *perceived*, it is investigated in terms of how it is *enacted*. Instead of relying on subjective perceptions of 'quality' and 'quantity' of L2 contact, the network study uses an explicitly structural concept – role equivalence – to describe how individuals' access to the L2 is constrained by others' interactions. A central tenet of the social context model (Clément, 1980) is thus re-confirmed: L2 contact predicts L2 self-confidence. Furthermore, rather than using a measure of subjective norms regarding L2 use, a network measure of cohesive subgroup is employed to delineate informal social groups within which norms emerge. The study therefore supports the

Ajzen's (2005) theory of planned behavior, in which social norms influence behavioral intention directly, independent of one's perceived behavioral control over that behavior. Future studies should seek to expand the concept of interpersonal contact and access beyond the limited notions of perceived 'quality' and 'quantity.'

Such an expansion of the notion of contact in the place of subjective perceptions is evident within Chapter 5, in which mediality (flow betweenness) is found to be an important predictor of L2 WTC. This result points to the potential salience of structural holes (Burt, 1992) in the investigation of L2 use. Opportunities for brokering information between otherwise disconnected groups may be particularly important for encouraging use of the L2. Yet, despite constituting perhaps the single-most robust and important empirical finding of the thesis, brokerage has drawn little previous interest in the relevant literature. Future studies might concentrate on this relationship between communicating across "real world" information gaps between groups, and its benefit to the motivation to use the L2, and potentially to the development of communicative competence as well.

### **6.2.2. Mutual causation and the nature of resources**

Within the current thesis, a further issue of causal order arises. In the study of cross-cultural adaptation presented in Chapter 4, L2 WTC is seen as impacting social relationships (as indicated by hassles with social isolation). By contrast, in the network study in Chapter 5, the configuration of relationships (as indicated by core discussion relationships) shapes behavioral intention. The result is a seeming contradiction: which comes first, the interpersonal relationship or interpersonal behavior?

In a review of social exchange theory as applied to organizations, Cropanzano and Mitchell (2005) address this issue of causal directionality. They maintain that "it is reasonable for relational benefits to be both a result and a resource for [social] exchange" (p. 889); relationships can lead to exchange, and, conversely, exchange can lead to (changes in) relationships. This mutually causative

relationship certainly seems intuitive. For instance, forming a new friendship involves a range of interactive behaviors rooted in cultural norms and meanings, including the initiation of conversations, offers of assistance and companionship, and instances of self-disclosure. At the same time, a friendship imposes rights (e.g., to ask for help) and obligations (e.g., to provide help) upon either individual, thereby enabling and constraining subsequent behavior and possibly leading to an even closer friendship. The causal relationship is therefore bi-directional.

Which causal direction prevails may depend on precisely what is being exchanged (Cropanzano & Mitchell, 2005). Repeated exchanges of widely recognized, relatively concrete resources (e.g., money, goods) help produce relationships of trust. In turn, established relationships of trust lead to the exchange of more particularistic, symbolic resources (e.g., commitment). Therefore, the *consequence* of one exchange becomes the *resource* to be exchanged in a future interaction.

This distinction between universal and particularistic resources is evident within the empirical studies in the current thesis. In the cross-cultural adaptation study (Chapter 4), *behavior alters the nature of relationships*: L2 WTC can be seen as a component of interpersonal communication behavior that helps to build up relationships, as well as the benefits that they provide (i.e., L2 communicative ability, psychological adjustment). Accordingly, the study examines sojourners' hassles involving relatively universal resources, including money and time. By contrast, in the network study (Chapter 5), the resource exchanged is quite particular to the individual – the discussion of matters that are personally important. Hence, in this study, *relationships alter behavior*: L2 WTC is regarded as the product of the structure of exchange relationships.

Therefore, while it can be assumed that behavior and structure are reciprocally causative in a general sense, a description of the state of relationship development (i.e., new or established) and the nature of the resource under exchange (universal versus particularistic) is essential to



determining which causal direction prevails at a given point in time. By means of explanation, Cropanzano and Mitchell (2005) offer the analogy of climbing a ladder in order to describe the mutually causative, ratcheting interplay between relationships and exchange behavior. Relationship states themselves can be imagined as the rungs of a ladder, and behavior as the action of ladder-climbing. The ladder-climbing behavior is needed to move between rungs; however, at the same time, each rung is a platform for subsequent ladder-climbing. In the early stages of relationships and group formation, the predominant process may be of behavior giving rise to structure.<sup>83</sup> Conversely, in “mature” relationships and communities, the prevalent causal direction may be of structure constraining and enabling behavior. Once the network reaches relative stasis, various emergent properties of the community structure, including group norms, likely impinge upon members’ subsequent behavior.

In the process of making such determinations between contexts and stages of development, the researcher addresses Larsen-Freeman’s (2007b) call for “cultivating a dialectical relation between parts and wholes in order to identify the appropriate functional units of analysis, which... require ongoing redefinition, depending on the inquiry” (p. 37). An imperative for the network researcher is to ask what one is observing: an establishing or altering of relationships through purposive, intentional action; or an engaging in exchange across an already-established interpersonal link. In other words, the research must decide what s/he is examining: reaching for the rung of a ladder, or pushing off from it. Indeed, in longitudinal studies of any length, the researcher may witness a reversal in predominant causal direction, with relationships chiefly influencing behavior in stable periods, and behavior altering relationships during times of change.

---

<sup>83</sup> However, this process may unfold rapidly, with status hierarchies forming quickly on the basis of various personal characteristics (Ehrman & Dörnyei, 1998)

### 6.2.3. “Networks of meaning” and the sharedness of future selves

As advanced by Granovetter (1985), Passy (2002), and others, and discussed from the outset of this thesis, an adequate account of human agency requires a balanced account of human action as embedded within social structure (see Sections 2.1.2 & 2.3.4). Such a perspective holds individuals as neither over- nor undersocialized, neither unquestioningly reproducing cultural norms on the basis of one’s social categories, nor shrewdly calculating objective cost-benefit ratios within a marketplace of anonymous exchanges. However, as Emirbayer and Goodwin (1994) succinctly point out, “[n]etwork analysis all too often denies in practice the crucial notion that social structure, culture, and human agency presuppose one another” (p. 1414). An adequate conceptualization of individual human agency therefore has been a weak point of social network analysis.

To remedy this shortcoming, theorists have approached the issue of embedded human action through the notion of *cultural narratives* (White, 1992; Padgett & Ansell, 1992; Emirbayer & Goodwin, 1994; Somers, 1994). A narrative approach holds that social life is essentially storied, not just in historical accounts, but in how it is experienced (Somers, 1994). As Somers remarks, “people are guided to act in certain ways, and not others, on the basis of the projections, expectations, and memories derived from a multiplicity but ultimately limited repertoire of available social, public, and cultural narratives,” (p. 614). These narratives guide our behavior by offering normative frameworks which crystallize some forms of action as ‘good’ or ‘pure’ and others as ‘corrupt’ or ‘impure’ (Padgett & Ansell, 1992). They are the lenses by which individuals appraise the relative acceptability – or even the sheer conceivability – of certain types of communication behavior across various situations.

Harrison White (1992) maintains that individuals are connected to cultural narratives by their ongoing social relationships. Social networks are therefore “networks of meaning,” not merely a structure of interactions somehow separated from cultural content and meaning. Network analysis’ ability to delineate communities of frequently interacting individuals suggests that it could

be fruitfully used to investigate which individuals are likely to co-construct social reality as a result of repeated encounters with one another.

The parallel notion of cultural narrative can be detected within Dörnyei's (2005; 2009) notion of the *L2-self*. Drawing on previous theorization within mainstream psychology, he contends that the self refers not only to one's self-knowledge at the current point in time, but also various possible future selves, some of which are comprised of self-determined aspirations (the desired self), and others are the product of introjected obligations and responsibilities placed upon the individual by others (the ought self). L2 selves are therefore one's current self-construct regarding L2 ability and use, as well as various visions of what one hopes to achieve, what one feels obligated to achieve, and what one fears of becoming in terms of L2 ability and use. These future selves represent guides for behavior, rooted in one's imagination. Dörnyei (2009) quotes Boyatzis and Akrivou (2006) who argue that:

[I]mages of the desired future... *once shared*, have the power to become a force, and in that sense an inspiration for social development and growth, for intentional change at many levels of social organization, not just for the individual. (p. 633; emphasis added)

It is therefore these future selves which imbue the individual with purpose and drive action towards achieving the desired future self, fulfilling needs in a self-determined manner.

In describing L2 self-system, Dörnyei (2009) suggests a tension which parallels that between agency and structure. On one hand, future L2 selves must be *possible* selves. Dreams must have some basis in reality; they may be aspiring, but not beyond belief. To a great extent, this reality is not a result of first-hand result of trial and error, but rather transmitted to us through cultural mediators (Feuerstein, 1980). Therefore, the multiple storylines that we locate ourselves in are largely not of our own making (Somers, 1994). They were already there – handed along to us through a chain of individuals, each of whom amended, adapted, and re-interpreted personal

dreams to suit his/her own specific needs and context. On the other hand, however, a core aspect of the L2 self-system is the individual's imaginative capacity in the face of these realities (Dörnyei, 2009). Imagination is seen as essential to transcending the here-and-now, allowing the individual to strive towards an achievable future state of being representing what s/he wants to become, versus what s/he fears becoming on the basis of others' expectations. This creative process is alluded to within the L2 self-system: "In the U.S., it is both a birthright and a moral imperative to tailor one's personal version of the American Dream" (Markus, 2006; cited in Dörnyei, 2009, p. 17). In other words, an imaginative capacity allows one to improvise on culturally salient storylines in an adaptive, innovative manner.

This improvisational capacity is also central to a network understanding of human agency. Padgett and Ansell (1992) remark that human agency relies on the idea that humans possess the "capacity... to appropriate, reproduce, and, potentially, to innovate upon received cultural categories and conditions of action in accordance with their personal and collective ideals, interests and commitments" (pp. 1442-3). Culturally-rooted concepts and narratives – for example, the "American Dream" or Confucian values of face and deference for authorities as discussed by Wen and Clément (2003) – are what the individual must adapt and alter to achieve his/her own possible future selves. However, despite being widely recognizable, cultural concepts and narratives are not adopted uniformly by entire social categories of individuals (Emirbayer & Goodwin, 1994).<sup>84</sup> Rather, they are passed on through interactions in an ongoing process of cultural reproduction that is inseparable from the structure of social ties along which transmission occurs.

This process of imaginative co-construction of social reality as it relates to L2 use is evident within a number of the studies reviewed above, most convincingly by Yashima and colleagues in their study of international posture among Japanese EFL students (Yashima, 2002; Yashima *et al.*,

---

<sup>84</sup> For instance, the vast majority of Americans are likely to have some idea of what the "American Dream" is (e.g., home and car ownership, family life, participation in voluntary associations, etc.). However, not all Americans adopt it as a personal goal, seeing it as either unrealistic or undesirable.

2004; Yashima & Zenuk-Nshide, 2008). As they argue, differing meanings, or narratives, emerge within different clusters of individuals. The learners' (and teachers') imaginativeness and creativity is evident in their joint co-construction of a community of learners that helps the individual to transcend firsthand experiences, connecting him/her to an achievable vision of L2 use.

The current thesis offers further indications of where cultural narrative might be fruitfully investigated. In the network study in Chapter 5, the effect of role equivalence on perceived L2 competence may indicate the importance attached to failed encounters. At this early stage in the adaptation process, individuals may not be placing instances of failed communication within a larger picture of a multicultural academic community, in which many students' wish to maintain some level of (L1-based) ingroup ties and ethnolinguistic identity within their new environs. For students coming from culturally homogenous societies, the trade-offs involved with an integrative mode of acculturation may be an unfamiliar experience. Unsuccessful L2 encounters may be the result not so much of inadequate communicative abilities on the part of students, but instead the ingroup preferences of one's interlocutor. Nonetheless, these individuals may (initially) interpret unsuccessful intercultural communication as indicative of their own ability, rather than as an uncontrollable incongruence between their own goals and that of their alters. Future investigations would benefit from continuing in this vein, though with more specific attention to how these narratives are created, altered, and maintained through ongoing social interactions.

#### **6.2.4. Disparity of opportunity**

With the emergence of constraints and opportunities inherent in various network positions comes a crucial, practical implication: interconnected individuals may face systematic disparities in terms of opportunities to use the L2 within a community of speakers. While individuals in advantaged network positions enjoy continued access to L2 interactions, those in disadvantaged positions are highly constrained. The potential result is that gaps in language acquisition and performance may be relationally maintained by the network structure, resisting individual efforts of

marginal individuals to access the social resources needed to realize personal goals associated with learning the L2.

The classroom and other social groups may therefore be simultaneously a social resource and a constraint on language learner. On one hand, the classroom and other less formal social groups may provide the learner with a regular supply of interlocutors with whom to use and practice the L2. Ideally, these individuals prompt the individual with opportunities, challenges, and threats that require use of the L2 to exploit, meet, or overcome. Furthermore, these groups may help individuals to better articulate attitudes relevant to the L2 and the learning situation, as well as help to sustain the motivation in the face of challenges, boredom and uncertainty. In all, the best case scenario is when students and teachers successfully co-construct imagined communities that connect the student to a larger social reality requiring use of the L2 (see Yashima & Zenuk-Nishide, 2008).

On the other hand, social groups may in some instances hold the individual learner back. For instance, the classroom group may form norms that are antagonistic towards learning the L2, hindering motivation and positive attitudes rather than promoting them. Alternatively, even if a group as a whole holds norms favorable towards L2 learning and use, some members may nonetheless find themselves at the group's periphery, excluded from valuable L2 opportunities provided by others. This position may be difficult to overcome, with status hierarchies rapidly taking shape and proving resistant to change.

The implication for teachers is an emphasis on simultaneous attention to community building, learner autonomy, and the individual needs of the learner. In their social constructivist approach to language learning and teaching, Williams and Burden (1997) place an emphasis on educating the whole person, already possessed of personal meanings, motivations, beliefs, and intentions. However, as Williams and Burden themselves make explicit, learners' various personal

motivations do not occur within a social vacuum, but instead are initiated and maintained, or alternatively dampened and dismissed, by the learner's current, ongoing social environment. The teacher therefore should be cognizant of how the individual learner's motivations may be highly dependent on interactions with classmates. The teacher must carefully consider whether this interdependence is an aid to L2 learning – initiating and sustaining L2 motivation – or a hindrance – constraining the behaviors of an otherwise motivated learner. Unfortunately, two students in the same class may have opposing experiences, with one benefiting and the other feeling marginalized. In the case of the latter, the teacher may be well-advised to emphasize more autonomous learning activities outside of the classroom group to either supplement the benefits provided by the classroom, or alternatively, to compensate for a lack of opportunities.

### **6.3. Limitations**

Despite what I argue is the essential contribution of social network analysis to the investigation of social context, the network approach to language learning and use presented in the current thesis contains a number of limitations that pose significant challenges to the construction of a more general framework for analyzing social systems. Specific limitations owing to instrumentation, sample size, and so forth have already been discussed within Chapters 4 and 5. Therefore, I will limit my discussion in this section to the most pressing restrictions of a social network approach: addressing the dynamic change in network structure over time, accounting for the importance of each individual learner's personal motivations for learning and using the L2, and incorporating overlapping contexts and non-dyadic social influences.

#### **6.3.1. Dynamic change over time**

One limitation of the current thesis has been the cross-sectional design of the empirical studies, which has preempted examination of changes in network structure over time. This limitation means that a number of questions relating to processes of tie formation, maintenance, and dissolution are left unaddressed. Consequently, rather than investigating this process directly,

certain assumption must be made as to the co-evolution of network structure and the development of individuals' L2 WTC. As discussed in Chapter 4, the interpretation of L2 WTC as a predictor of enhanced person-environment fit requires an assumption of relative stability in trait-like L2 WTC, supported by looking exclusively at sojourners who had been in the UK for at least four months. In Chapter 5, the (partially) causative role of network structure on students' trait-like L2 WTC is likewise assumed: L2 WTC is viewed as a disposition that is learned from and attuned to one's regularized patterns of social interactions, as summarized by social network structure.<sup>85</sup>

Following the course of relationships is needed to confirm that these structural-dynamic assumptions have actually been appropriate. Indeed, longitudinal investigations are needed to gain a fuller understanding the dynamic interplay between changes in relationship structure, and any sort of dynamic, developmental change within the language learner. In all, discerning the prevalent causal relationship between structure and behavior is essential to grasping the interrelationship between agent and environment.

### **6.3.2. Personal motivations**

A second, aforementioned limitation of the research design resides in the lack of treatment of each person's individual, potentially idiosyncratic motivations for learning the L2. As discussed at length in Chapter 2, network analysts have been hesitant to incorporate sophisticated accounts of human motivation into their explanations of social structure. This reluctance owes both to a wish to avoid reductionism, and out of an understandable desire to focus first and foremost on system, leaving the issue of motivation to psychologists (Kadushin, 2002; Robins & Kashima, 2008; see Section 2.3.3). In a similar vein, the empirical emphasis of the current thesis has been on the

---

<sup>85</sup> This assumption is bolstered by the measures used: the L2 WTC and perceived L2 competence scales asked about *current* tendencies, while the network measure was retrospective, asking about interactions during the prior two weeks. Also, the L2 WTC scale asks about three relationship types: friends, acquaintances, and strangers, thereby assessing the relationship between *pre-existing* relationships and *current* L2 WTC.



*interdependence* of language learners, who rely on each other to provide resources needed for basic social functioning and opportunities for interaction.

Largely neglected, however, have been learners' various personal, potentially idiosyncratic motivations whose fulfillment is either enabled or constrained by this interdependence. In Chapter 4, it was merely assumed that individuals are generally motivated to function socially in some way to achieve a more adaptive fit with the host environment. In Chapter 5, the issue of motivation was largely sidestepped, with the acknowledgement that language learners have varied and personal motivations for using the L2, and may therefore use the L2 in different ways with different people at different times. As a result, I examined the quite general activity of core discussion – talking about 'personally important matters' – without specifying what those important matters are, or in what form(s) of activity that discussion took place.

This lack of specificity obscures the practical implications of the study. I can conclude that relationships matter, and do so in various ways. However, missing is an account of which resources and interactions the individual sojourner considers to be important – not only to survive, but also to thrive. Absent are the specific *types* of meaningful activities in which 'core discussion' take place. Irretrievable is an analysis of the contextual and situational factors which facilitate social interactions, which likely vary considerably from person to person and from time to time. Consequently, Ushioda's (2009) notion of the "person-in context," in which the individual is viewed as a "thinking, feeling human being, with an identity, a personality, a unique history and background, a person with goals, motives and intention" (p. 220), provides a desirable conceptual ideal, yet could not be addressed within the current thesis.

### **6.3.3. Overlapping and non-dyadic contexts**

A further set of limitations of a network approach relates to integrating network analysis into a more comprehensive approach to social context. First, the approach taken in Chapter 5 is

confined to the analysis of a lone network conceptualization. While the notion of ‘core discussion’ activity is likely a highly salient – though general – social activity, it is ultimately just a *single* form. As argued by Mischel and Shoda (1995) and Funder (2006), behavioral dispositions may be better understood in terms of the individual’s various phenomenologically-defined situations. As such, in investigating behavioral disposition, it is beneficial to consider the multiple forms of social activity that one enters into. Consequently, network investigations of L2 WTC as an intraindividual pattern of behavioral variance might make use of multiple networks, each one corresponding to a psychologically-salient situation-type.

A central issue thus becomes how to select networks for inclusion in examinations of behavioral disposition. A complicating factor is the lack of a sufficiently developed typology of social relationships that hinders the formulation of guidelines for selecting among multiple possible networks (Laumann, *et al.*, 1989). Needed, therefore, is a general strategy for defining and selecting optimal social networks that specify more detailed forms of social activity, while still allowing more particular aspects of those interactions to vary (e.g., ‘classroom helping network,’ ‘advice network,’ etc.). Such an effort would be aided by a fuller understanding of the situation as psychologically defined, with particular attention devoted to the issue of whether individuals’ subjective experience of social situations is more or less an accurate reflection of an objective reality (Funder, 2006), or is derived in a much more idiosyncratic manner (Mischel & Shoda, 1995).

A further obstacle to examining multiple networks is their statistical treatment. The ego-centric approach generally looks at how the individual may be conceived of as the intersection of his/her various social memberships. However, by design it does not look beyond ego’s direct ties. Meanwhile, sociocentric approaches to multiple networks are still limited (though see Borgatti & Cross, 2003), though efforts are being made to integrate multiple networks into dynamic actor-based models (Snijders, *et al.*, 2010).

A further, related limitation is in integrating social influences that are not readily described in terms of proximal, dyadic social processes. For instance, in the L2 WTC model, MacIntyre et al. (1998) hold an all-encompassing view of L2 use which includes non-interpersonal activities such as reading and listening to mass media. Kim (2001) incorporates consumption of mass communication as an important component of engaging with the host environment, alongside participation in interpersonal relationships. Such a perspective highlights the fact that language behavior is not limited to dyadic, interpersonal interactions, but is also keenly and importantly linked to the use of openly available sources of information, such as the internet, television, print media and so on. Given its relatively autonomous nature, the use of mass media falls outside of the grasp of a network approach, at least in part. Required is a more holistic approach to looking at social context, of which social network analysis is an important and useful, though not singularly sufficient, component.

## **6.4. Future directions**

Ultimately, therefore, in a foregone conclusion, social network analysis cannot answer every pressing question facing the study of L2 learning and use as situated within various overlapping contexts. The question becomes how network analysis might be fruitfully integrated with other approaches to provide a richer explanation of the various social processes involved in L2 acquisition, while not impeding the analysis of L2 learning and use as a complex, dynamic process. As I argue in the final section of this thesis, the promise of social network analysis to future studies of L2 learning and use lie in its place within both computational modeling, and in qualitative investigations. Accordingly, I outline two general future directions: computational network models of observed speech communities, and the integration of network analysis into mixed methodologies.

### **6.4.1. Computational modeling of networks**

A further limitation of the network approach as employed in the current thesis has been the statistical models used. In the empirical investigations in Chapters 4 and 5, the methods used offer relatively modest adjustments to conventional methods. Still-evolving models of inferential statistics

depart much more drastically from the traditional suite of inferential statistical models, offering a higher degree of reliability, but also great complexity, in network measurement. In particular, Exponential Random Graph Models (ERGM) allow modeling the exogenous (i.e., personal attributes) and endogenous variables (network effects) that lead to the observed configurations of *empirical* networks (as opposed to simulated ones). As such, this method views network structure as an outcome or dependent variable (Robins, *et al.*, 2007). In addition, a newer, related method known as stochastic actor-based (SAB) modeling – implemented in the statistical program SIENA (Snijders, *et al.*, 2010) – does permit for analysis of the co-evolution of networks and behavior, and thus has the major advantage of testing a given behavior as both a cause and effect of network variables, accommodating longitudinal data in the form of several waves of network data. This particular method therefore addresses dynamic change in networks, as outlined above.

Nonetheless, given the data completeness requirements associated with the analysis of network data, empirical networks methods can be extremely resource-intensive, requiring potentially a great deal of access and compliance on the part of research sites and participants. Furthermore, the statistical methods currently only incorporate very local network features (e.g., transitivity, reciprocity, degree), to the exclusion of global ones (e.g., flow betweenness, role equivalence, etc.) examined within Chapter 5. However, once these models are advanced to the point where they may accommodate these more global measures, cross-sectional studies such as that found in Chapter 5 will provide an important basis for further investigation of mutual causation.

#### **6.4.2. Mixed methods**

Arguing for the use of qualitative approaches to investigating language as a dynamic system, Dörnyei (2009a) maintains that computational modeling is inadequate for examining the complexity of cognitive and social systems, in part due to the extensiveness of confounding variables. Qualitative approaches, by contrast, hold the promise of richly describing the whole person with various motivations, attitudes, and intentions. Furthermore, given the relative ease with which

longitudinal designs may be incorporated, qualitative approaches can effectively capture language learning as a dynamic process.

However, qualitative methods used thus far in the investigation of situational L2 WTC have lacked the ability to take into account why a given interaction occurs in the first place, with researchers often intervening to orchestrate such interactions for the purpose of observation. For instance, MacIntyre and Legatto's (2010) idiodynamic experimental method uses controlled observations to hone in on the precise interaction of social demands with cognitive, affective, and motivation factors. In doing so, it levels out the person's countervailing identities and situational pressures (see also Robins & Kashima, 2008). Not treated is how the individual has agreed to the importance of scholarly research, committed to the role of participant, and complies with that role throughout the duration of the experiment/encounter.

A network approach may compensate for this leveling out of relational information in the use of these methods. While network analysis cannot examine the precise moment of L2 use, it is ideal for the analysis of the aggregation of interactive encounters which serve to establish and maintain one's social ties and wider network position. Indeed, a network approach cannot focus in on "crossing the Rubicon," as can studies of situated L2 WTC. However, a socio-centric network approach does show how interactions contribute to a larger, ongoing learning process in which the individual routinely and repeatedly confronts differential sets of L2 opportunities and alternatives. As a result, a network approach is appropriate in investigating longer-term developmental trajectories, rather than in the momentary rise and fall of L2 WTC within an interaction, though the two complement each other well. Ultimately, a network perspective permits the researcher to see who is relatively independent from any single other individual for interaction, and who is more reliant on a single interaction partner. In such a way, it is possible to ascertain who has an easier path to success in terms of entering into discourse, and who is constrained in their use of the L2.

In future investigations, a network approach may serve as an important component of a wider toolkit of mixed methods (see Dörnyei, 2007 for overview of mixed methodology). In particular, a whole-network (sociocentric) approach allows one to look beyond the face-to-face processes by which individuals share social meaning. It permits one to delineate the sub-communities and social positions, as well as give indications of the social processes possibly involved in the formation of these structural features. Such an approach would provide a rich, overarching survey of the system of social interactions ongoing within the community, akin to that found in Eckert's (2000) investigation of sociolinguistic variation as social practice in an American high school, though in considerably more detail. Through a variety of network-analytical concepts, the researcher may better pinpoint particular individuals and social processes for observation within the community. For instance, a potentially fruitful tactic might be to conduct interviews with individuals occupying highly medial positions, as well as those embedded deep within dense areas of the networks, and to investigate if and how these individuals differ in terms of motivational processes, such as making causal attributions for successful and failed cross-cultural encounters.

In summation, the current thesis demonstrates the utility and promise of a social network approach to L2 learning and use. The approach portrays language learners and humans in general as more than simply their inner cognitive and affective workings, but also as their external social regularities, and how they use those regularities to get things done. I consider the further development and use of a social network approach to be a worthwhile endeavor that complements the ascendant dynamic systems paradigm within SLA. However, as seen, a network approach is not an all-encompassing, all-answering methodology, but will require incorporation with other techniques in order to provide a fuller understanding of language as emerging from the interactions of its users. Overall, despite its computational nature that may at times prove arcane, a network approach at its core contributes to a graspable common discourse that bridges qualitative and

quantitative-computational approaches. Indeed, given its importance, new researchers would benefit from being exposed to network analysis earlier and more systematically in their training.

## Appendices

### Appendix A: Glossary of network terms

<b>Adjacent</b>	connected directly (rather than indirectly through intermediaries)
<b>Alter</b>	an actor directly connected to the focal node (i.e., <i>ego</i> ) is tied directly
<b>Betweenness</b>	a canonical measure of centrality defined as the proportion of all geodesic paths in a network which pass through the focal node (Freeman, 1979); variants exist
<b>CATREGE</b>	(CATegorical REGular Equivalence) algorithm for detecting regular equivalence exclusively with multirelational data.
<b>Centrality</b>	a family of measures that summarize the node's connection to other nodes within the network (see radiality and mediality)
<b>Clique</b>	a restrictive definition of a cohesive subgroup in which each member is connected to every other member node
<b>Closeness</b>	a canonical measure of centrality defined as the sum of distances from the focal node to all other nodes in the network (an inverse measure of centrality) (Freeman, 1979); variants exist
<b>Cluster</b>	a general term describing a set of nodes or actors that are disproportionately tied to one another; arises in part from transitivity
<b>Cohesion</b>	the interconnectedness of nodes/actors
<b>Degree</b>	a canonical measure of centrality defined as the sum of adjacent alters (also referred to as point centrality) (Freeman, 1979); variants exist
<b>Density</b>	the actual number of ties in a graph divided by the total number of possible ties
<b>Distance</b>	the amount of (social) space between two actors/nodes calculated from the number of intermediary links between those actors; various definitions exist (see <i>Geodesic</i> ; see also Appendix C.2.1)
<b>Ego</b>	the focal node
<b>Ego-centric</b>	pertaining to a network defined in terms of a focal actor ( <i>ego</i> ) and his/her direct ties ( <i>alters</i> ); also referred to as <i>personal</i> network
<b>Geodesic</b>	the shortest path (through intermediaries) between a pair of nodes/actors
<b>Graph</b>	a collection of nodes and vertices; a network



<b>Homophily</b>	the phenomenon in which actors similar on some attribute are socially linked to one another, either through selection or influence.
<b>K-plex</b>	a less restrictive definition of a cohesive subgroup of size $n$ in which each member node is connected to at least $n-k$ other members nodes
<b>Name generator</b>	a question used to elicit the names of alters on some theoretical basis (i.e., role relation, affect, interaction, social exchange)
<b>Node</b>	the intersection of various ties (see also actor)
<b>Reciprocity</b>	the tendency to match some form of social exchange with an alter who first provides it (e.g., acknowledging a friendship with one who recognizes it first)
<b>REGE</b>	(REGular Equivalence) algorithm for detecting regular equivalence with directional and/or multirelational data
<b>Regular equivalence</b>	the extent to which two nodes are connected (and unconnected) to the similar types of nodes; the most abstract form of role equivalence (see Section 2.3.2.)
<b>Role equivalence</b>	the extent to which two nodes have similar patterns of ties; various definitions exist (i.e., structural, automorphic, regular equivalence)
<b>Sociocentric</b>	pertaining to a network representing a bounded community of multiple nodes
<b>Tie</b>	a social link between two actors on some dyadic basis, such as similarity, role relation, interaction, social exchange, affect, and so on (see Section 2.1.1.)
<b>Transitivity</b>	the tendency to form new ties with an alter's alter (e.g., a friend-of-a-friend becoming one's friend); leads to clustering

## Appendix B: Issues with network data

### B.1. Autocorrelated Data

In a matrix of dyadic data, values found within the same rows and columns are assumed to be autocorrelated to various degrees. In other words, rather than each value deriving independently from a distribution of probabilities, it is based to some degree on the values in other cells in the same row and/or column. As an example, interdependencies become evident within the distance matrix. Consider the shaded cells in Figure B.1. The direct connection between  $a$  and  $b$  ( $d_{a,b} = 1$ ) means that the distance between  $a$  and  $c$  is 2 ( $d_{a,c} = 2$ ), rather than infinite. Thus, the two values ( $d_{a,b}, d_{a,c}$ ) are interdependent; the value in one cell impacts the value in another. It is this interdependence within rows/columns that violates the assumption of independent observations.

<i>Adjacency</i>				<i>Geodesic Distance</i>			
	<i>a</i>	<i>b</i>	<i>c</i>		<i>a</i>	<i>b</i>	<i>c</i>
<i>a</i>	0	1	0	<i>a</i>	0	1	2
<i>b</i>	1	0	1	<i>b</i>	1	0	1
<i>c</i>	0	1	0	<i>c</i>	2	1	0

**Figure B.1.** Example of autocorrelated data.

As Krackhardt (1988) notes, increasing levels of autocorrelation among notes leads to greater and greater bias in standard Ordinary Least Squares (OLS) regression. Interdependence of network data will tend to constrain the variability of the data sample, and can lead to Type I error (false positive results). However, in network data, this interdependence is not uniform across rows/columns.<sup>86</sup> This is evident in the common finding that degree and closeness are often highly – though not perfectly – positively correlated. This is significant, as it means that the autocorrelation cannot be corrected for, as in cases of temporal autocorrelation. Lacking an approach to correct for

<sup>86</sup> This differentiates network data from temporally autocorrelated data, in which the rate of autocorrelation can be modeled as a uniform factor of time (Krackhardt, 1988).

autocorrelation in the data, one solution is to use nonparametric versions of standard statistical tests.

## **B.2. Generalizability**

The interrelated nature of the data has wider theoretical implications for generalizability. As Hanneman and Riddle (2005) note, mathematical sociology, of which social network analysis is a branch, traditionally views data as “deterministic.” Observations are not considered samples of a larger population or system, but rather the entire population itself. Thus, description of the network through various measures is regarded as fully sufficient for its analytic purposes. Despite this stance, in practice, network analysts are generally interested in network measures as “probabilistic realizations of an underlying true tendency or probability distribution” (p. 13). Given that network measures are readily represented in numerical form, researchers widely employ methods of statistical inference.

Hypothesis testing of network data thus takes the form of testing departure from randomness. This random distribution is created randomizing (permuting) the data sample itself (see Good, 2000). In this procedure, the test statistic is computed in the same way as with conventional inferential methods. Next, each case of the dependent variable is randomly re-assigned to a case of independent variable(s) and the test statistic is recomputed. This permutation step is repeated many thousands of times, creating a distribution of scores derived from randomness. The actual test statistic is compared against this random distribution (as opposed to an assumed normal distribution). As in conventional methods, if the actual test statistic is more extreme than a critical percentage of the distribution (5%, 1%, 0.1%, etc.), it is considered a statistically significant departure, though this departure is from randomness, rather than from a theoretical total population that takes a normal distribution.

Therefore, the question of hypothesis testing becomes whether the observed test statistic might be found purely by chance among other hypothetical networks *similar to the observed one*. Networks of different sizes and densities, and those composed of different attributes, might yield different distributions of centrality scores, homophily patterns, cohesive subgroups, equivalent subgroups, and so on. Therefore, they must be subject to their own respective testing. Generalizability, therefore, rests not only on the degree to which individual participants are representative of the total population of interest, but also the extent to which the network (and its constituent features) represent a 'typical' network.

### **B.3. Missing data**

Missing data is a pressing issue in network analysis, much more so than in traditional quantitative analysis. Due to the interdependent nature of the data, the omission of an important node or even a single key relation can impact the measure score for *other* nodes in the network (some or all, depending on the measure itself). The degree of the disturbance caused by a missing relation or set of relations can be minimal or drastic.

A number of studies have investigated this issue (Galaskiewicz, 1991; Costenbader & Valente, 2003; Borgatti, *et al.*, 2006). In all, the results are mixed. Costenbader and Valente (2003) cautiously conclude that only a few centrality measures (e.g., in-degree, eigenvector) are stable across declining rates of response. Global measures – betweenness and closeness – were considerably less stable, behaving erratically in some data sets. They note an important factor within missing data is whether it is missing at random, or if it is missing in association with some attribute of the nonrespondents.

By contrast, however, Borgatti *et al.* (2006) find a more graceful decay of centrality measures under increasing levels of randomly introduced erroneous data, with global measures performing only slightly worse than local measures under conditions of missing data. However, one

important difference between this study and previous ones is the use of randomly generated networks, rather than empirical ones. While this permitted precise differentiations in network size and density, and thus aided in drawing clearer-cut comparisons of these features, it is unclear if the random generation of these models sufficiently mimics the configurations of actual human social networks. In all, there seems to be reason to believe that local measures of centrality (e.g., degree) are safer under conditions of missing data than are global measures, as the latter rely on a greater number of data points. Obtaining valid global measures, meanwhile, is more dependent on near completeness of network data.

#### **B.4. Informant recall**

In a series of studies, Bernard, Killworth, and Sailer compared participants' recall of interactions against automatically recorded interaction data from a range of actual and virtual social settings (Bernard & Killworth, 1977; Bernard, *et al.*, 1980; 1982). Among their conclusions were: participants are generally very inaccurate (< 50% accurate) in recalling individuals with whom they had previously interacted; participants recalled interactions better when asked about interactions over longer timeframes (though this effect was small); and asking about "important" or "significant" alters generally produced the same responses as asking about who participants interacted with (Bernard, *et al.*, 1984). In all, the results cast doubt on the validity and reliability of using retrospective network data.

Faced with this pressing issue of whether or not the field's questionnaire-dominated methodology suffered major validity and reliability issues, Freeman and Romney conducted further investigations (Freeman & Romney, 1987; Freeman, *et al.*, 1987). Examining participants' recall of which members attended one in a series of university seminars, they found particular biases in their responses that were nonetheless revealing about social structure. While informants were indeed inaccurate in recalling specifically who attended a particular session, the responses of regular

attendees accurately reflected *typical* attendance. Individuals thus appear to perform well in recalling long-term patterns of interaction.

Freeman and Romney (1987) attribute this result to schematic effects on memory. Citing an array of literature in cognitive psychology, they adopt an organizational view of memory. In recalling one in a series of similar events, individuals access a general prototype of that event, rather than the specific event itself. Their expectations of a typical event fill in the gaps of elements that were lightly attended to during the actual event. An individual's expectations are honed in proportion to the level of his/her past participation in the social structure (i.e., level of attendance at seminars), and thus how well-developed his/her mental schema is of the events as a whole.

## Appendix C: CATREGE and REGE algorithms

Regular equivalence can be computed using different methods. As seen in Chapter 5 (Section 5.2.5), two particular algorithms are used: CATREGE and REGE (Borgatti & Everett, 1992b). Although the two algorithms can produce similar results, they do not necessarily always do so, depending on the specific nature of the data. These algorithms therefore can advance different notions of what role equivalence, leading to issues with conceptual rationale. There are several reasons for this, the most basic of which is how either algorithm treats *multiple relationship types* (see Figure C.1.)

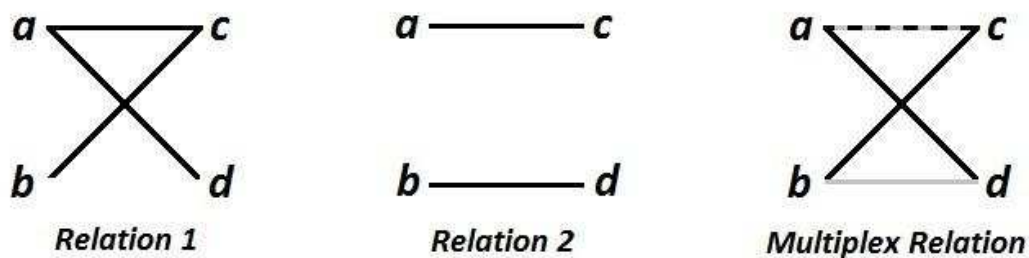

**Figure C.1.** Two hypothetical relations and their multiplex combination. Adapted from Borgatti and Everett (1992b, p. 362).

### C.1. CATREGE

CATREGE *requires* more than one kind of tie. It treats these ties by combining multiple relationships into a single *multiplex* matrix (see Figure C.1). Every distinct ‘bundle’ of relations is represented in a single multiplex matrix by a unique number. Relations are combined to create a multiplex matrix constituted of categorical relationship types. The main strength of CATREGE (“categorical REGE”) is that it reliably finds a single, intuitive notion of “regular similarity.” CATREGE is thus useful not only analytically, but also in grasping the concept of regular equivalence more generally (Borgatti & Everett, 1992b). However, it is important to note that as the data is nominal, each relationship bundle is treated as equally distant from one another.

In the first meaningful iteration, nodes are partitioned into classes based on having the *exact same set* of multiplex relationships; quantity of each tie type, however, does not matter. In the next iteration, the algorithm looks at the node classes that each node is tied to. If two nodes are in the same class, but each is tied to different types of node, the two nodes will be split into separate classes at the following iteration. For example, if nodes *i* and *j* are members of the same RE class *A*, but *i* is connected only to other members of *A*, while *j*'s neighborhood includes nodes from class *B*, then *i* and *j* will be placed into different classes at the next iteration. The number of node-classes increases with each iteration until all nodes (except perfectly regularly equivalent ones) are placed in their own unique class.

## **C.2. REGE**

REGE's treatment of both relations separately proceeds in a different fashion. On the first iteration, each pair of nodes is awarded points based on the number of relationship types that each pair shares. This is divided by the total number of possible equivalences between the pair, forming an initial equivalence score for the pair (ranging from 0 to 1). Successive iterations repeat this step, but weight the point-system using the prior iteration's equivalence scores. The number of iterations is set by the user, though three is now considered to be convention.<sup>87</sup> This happens for both matrices. The result is a matrix of dyadic ratio data (rather than nominal data, as in CATREGE).

### ***C.2.1. Distance: Geodesic versus Frequency Decay***

In Chapter 5, two models are used. REGE Model 1 looks only at direct ingroup and direct outgroup ties in the core discussion network, and will be described at length in the following section. REGE Model 2 is similar, but rather than using direct L1 ties, uses frequency decay distances between L1 ties. Introduced by Burt (1976; 1988), this transformation indexes the likelihood of actor *i* initiating interaction with actor *k*, based on the surrounding social structure.  $d_{ij}$  is measured as the

---

<sup>87</sup> This can be interpreted as the number of steps it takes before influence stops. In other words, at three iterations, a node's RE class will be affected by nodes who are three steps removed.



proportion of actors (including oneself) that the focal actor  $i$  can reach in the same number of steps (or less) that it takes to reach actor  $k$ :

$$z_{ij} = 1 - d_{ij} = 1 - \begin{cases} 0, & \text{if } i = j, \\ \frac{N_k}{N_j}, & \text{if } i \neq j, \text{ where } k = g_{ik} \leq g_{ij} \\ 1, & \text{if no path connects } i \text{ and } j \end{cases}$$

where  $N_k$  is the number of nodes reachable in  $k$  steps, and  $g_{ik}$  is the length of the geodesic path from  $i$  to  $k$ . In other words,  $z_{ij}$  is the proportion of actors directly and indirectly connected to  $i$ , who have *longer* geodesic paths (i.e., more distant) to  $i$  than  $j$  does. This can be re-cast as the likelihood of initiating interaction.

This function incorporates two common assumptions made by network analysts. First, when looking purely at social structure, an actor is less and less likely to interact with actors who are farther and farther away. The second assumption is that an actor's time for interaction is finite. Therefore, the odds of actor  $i$  interacting actor  $j$  diminishes with every actor  $k$  who is as close or closer.

## **Appendix D: Permutation-based analysis tools**

Drawing inference of network data requires a departure from conventional multivariate statistical analyses that rest upon assumptions of independence and normality. Adaptations of and alternatives to these methods are used instead, as network data is, by definition, relational. The interdependent nature of network data means that assumptions of independence required by conventional inferential statistics are not met.

### **D.1. Analysis of node-level data: Permutation-based OLS**

For the analysis of node-level information, an adapted version conventional Ordinary Least Squares regression which incorporates permutation testing is used to determine significance (UCINET VI, Borgatti, *et al.*, 2002). Beta coefficients and R-squared are computed using conventional OLS. However, instead of comparing the coefficients against a theoretical normal distribution to determine level of significance, significance-level is determined by comparing the coefficients against a distribution of coefficients computed from many random permutations of the data.

Several studies caution about the *potential* for biased parameter values that can result from the use of OLS on network autocorrelated data, with increasing levels of risk associated with increasing levels of autocorrelated data (Doreian, 1980; Doreian, Teuter, & Wang, 1984). Consequently, the results of nodal OLS must be interpreted with some caution, as the parameters themselves are potentially skewed.

### **D.2. Analysis of dyadic data: Quadratic assignment procedure (QAP)**

In the case of simple and multiple regression using dyadic (matrix) data, Krackhardt (1987; 1988) proposes the use of the *Quadratic Assignment Procedure* (QAP; Hubert and Schultz, 1976, cited in Krackhardt, 1987; 1988). QAP is essentially the same as OLS with two major exceptions: independent and dependent variables are expressed as matrices in order to accommodate dyadic data; and significance testing is conducted in such a way to account for autocorrelation of data. It

provides robust results in the face of interdependent data. QAP proceeds in the following fashion, as summarized by Nagpaul (2003):

1. The rows of the dependent variable matrix are concatenated into a single string (without the cells corresponding to self-ties – the diagonal of the matrix), producing a row that is  $n(n-1)$  characters long ( $n = \#$  of nodes).
2. The rows of the regressor matrices (independent variables) are concatenated in the same way.
3. OLS regression of the dependent concatenation on the explanatory concatenation(s) is performed to obtain regression coefficients and R-squared.
4. Rather than comparing the resultant coefficients against a normal distribution to test for significance, a null hypothesis distribution is produced by means of a restricted permutation test, in which:
  - a. The rows and columns of the *dependent* matrix (but *not* the independent matrices) are randomly permuted. *However, row- and column-interdependencies are maintained.* Values in the same row in the observed dependent matrix will remain in the same row, and values in the same column remain in the same column. This essentially represents a random ‘relabeling’ of the dependent matrix (XXXXXX).
  - b. OLS regression of the permuted dependent variable on the (unpermuted) explanatory variables is performed (repeat of Steps 1 – 3), and the new coefficients are recorded.
  - c. Steps 4a and 4b are repeated thousands of times, producing a null hypothesis distribution.
  - d. The level of significance for each predictor variable is determined by counting the proportion of the null hypothesis (i.e., permuted) distribution of the coefficient that is more extreme than the observed coefficient (for two-tailed tests).

There are limitations of QAP. First, QAP is not equivalent to OLS. Conventional regression and QAP with absolute difference data each summarize the distance between raw scores differently. Pearson's  $r$  (and, by extension, OLS regression) both use the conventional cross-product: nodal scores are pooled into a sample mean used in formulating the deviation score. By contrast, in QAP, the absolute difference between every pair of node scores is treated as a unique score. This makes the measure more sensitive to extreme scores. This difference is analogous to the difference between the two primary measures of spatial autocorrelation – Moran's  $I$  and Geary's  $C$  – which, while highly correlated, are not identical (Griffith, 1987; cited in Sawada, 2009). As Faust and Romney (1985) point out, the use of QAP with highly skewed data can produce unstable results. As seen in Table 5.4, several dyadic variables are moderately skewed, especially flow betweenness similarities. Subsequent analyses must take account of this.

Second, QAP can readily accommodate data regarding group membership, and test for relationships to other variables. What it cannot do is compare the means for these groups, as one would with ANOVAS and/or T-tests. Consequently, in some instances, follow-up test of means comparison will be conducted in order to further understand certain relationships.

### **D.3. Clustering and homophily: Permutation-based ANOVA-type tests**

The typical configuration of human social networks is as composed of homophilous, multiple dense clusters sparsely linked to one another by bridging connections (Newman & Park, 2003). Accordingly, various network hypotheses pertaining to centrality and cohesion – such as those found in Chapter 5 – rely to a large extent on the assumption that the flow of information is localized within clusters. UCINET VI (Borgatti, *et al.*, 2002) contains various permutation-based models to test for clustering and homophily.

In testing for homophily, it is necessary to see if the likelihood of an ingroup (or, conversely, outgroup) tie is significantly more likely than it would have been if individuals assorted purely on a

random basis. Various models test for homophily under different assumptions. Two models are used in Chapter 5. The first model used tests whether there is any preferential pattern in tie formation, regardless of its type (e.g., Group A might prefer ingroup ties, Group B might prefer ties to Group C, while group C might hold no pattern). The second model is a “variable homophily” model, which allows the rate of ingroup to vary by group. In these models, the presence or absence of a network tie is regressed on dummy variables corresponding to each cell of the group-by-group density matrix (Hanneman & Riddle, 2005).

In testing for such clustering, it is necessary to examine whether the network is better represented as a core-periphery structure, in which individuals have coalesced into a single large cluster, or as a structure composed of multiple factions. The core-periphery model seeks to group nodes into a single, interiorly dense cluster, and a spare outer ring. The factions algorithm seeks to fit nodes into a number of dense clusters. The number of clusters is specified by the user. Both procedures return a goodness of fit measure ranging from 0 (poor fit) to 1 (excellent fit) (Hanneman & Riddle, 2005).

## Appendix E. Scale Items

### E.1. L2 WTC and perceived L2 competence scales

#### ***E.1.1. L2 WTC outside the classroom scale items, adapted from MacIntyre et al. (2001) (Chapter 4).***

##### *Task-like situations factor*

Listen to instructions in English and complete a task. [Almost never (1) – Almost always (5)]

Bake a cake if instructions were only in English.

Play a game in English, for example Monopoly.

Imagine that you are confused about a task you must complete. How willing are you to ask for instructions or clarification in English?

Speak to your teacher or professor after class about an assignment.

Fill out an application form in English.

##### *General social situations factor*

Talk to an English-speaking friend while waiting in line.

Take directions from an English speaker.

Speak in English in a group about a recent vacation that you took.

Describe the rules of your favourite game in English.

Imagine that a stranger enters the room that you are in. How willing would you be to have a conversation in English if he talked to you first?

Try to understand an English-language movie.

#### ***E.1.2. L2 WTC scale items, adapted from McCroskey and Richmond (1987) (Chapter 5).***

##### *L2 WTC with friends subscale*

Talk in English with a friend while in queue [0% of the time - 100% of the time]

Talk in English in a small group of friends

Talk in a large meeting of friends in English

Present a talk in English to a group of friends

*L2 WTC with acquaintances subscale*

Talk in English with someone you have met before while waiting in queue

Talk in English in a small group of people you have met before

Talk in English in a large meeting of people you have met before

Present a talk in English to a group of people you have met before

*L2 WTC with strangers subscale ( $\alpha = .86$ )*

Talk in English with a stranger while standing in line

Talk in a small group of strangers in English

Talk in English in a large meeting of strangers

Present a talk to a group of strangers in English

*Distractor items*

Talk with a cleaner in English

Talk with a doctor in English

Talk in English with a salesperson in a store

Talk with a police officer in English

Talk in English with a waiter/waitress in a restaurant

Talk with a secretary in English

Talk in English with a garbage collector

Talk in English with a wife/husband (or girlfriend/boyfriend)

***E.1.3. Perceived L2 Competence scale (Clément & Kruidenier, 1985) (Chapters 4 & 5)***

I speak English [1 (Not at all) – 9 (Fluently)]

I understand spoken English

I read English

I write English

## **E.2. Daily Hassles and Perceived Stress scale items**

### ***E.2.1. Cross-cultural Daily Hassles scale (Chapter 4)***

#### *Time and financial constraints*

Not enough money for essentials. [No problem or annoyance (1) – Strong annoyance (5)]

Not enough rest.

Not enough time to do the things that must get done.

#### *Social isolation*

Foreigners living in your home.

Not enough social contacts.

Loneliness.

Difficulties with friends.

Friends and/or parents are too far away.

#### *Communication hassles*

Difficulty explaining your thoughts in order to be understood.

To have to speak English.

Do not understand English well enough.

Anxiety regarding your ability to meet student standards.

Limited knowledge of British culture and customs.\*

\*excluded from final analysis



### ***E.2.2. Intercultural Hassles scale (Chapter 5)***

Difficulty explaining your thoughts and ideas by speaking. [(1) Not a worry – (5) Always]

Not enough time to do the things that must get done.

To have to use English for everyday tasks outside of class (e.g., shopping, speaking with university administrators)

Difficulty finding sources for your course assignments (essay, presentation, or seminar).

Worrying if you are going to pass PEAP.

Difficulty explaining your thoughts and ideas in writing.

Too little knowledge of British culture and customs.

Not knowing how good your English needs to be to start your course.

Not understanding English well enough.

### ***E.2.3. Perceived Stress scale (Lemyre & Tessier, 1988) (Chapter 4)***

I am tense.<sup>2</sup> [Not at all (1) – enormously (8)]

I feel pressed for time.\*

I have the tendency to skip meals and forget to eat.<sup>1</sup>

I have physical pain: backache, headache, neck ache, stomach ache.<sup>2</sup>

I am preoccupied, tormented, and worried.

I forget meetings or things that I have to do.<sup>1</sup>

I am calm. (REVERSED)\*

I sigh heavily or I catch my breath suddenly.<sup>2</sup>

I am anxious, worried or distressed.\*

I feel a lot of pressure on my shoulders.\*

<sup>1</sup> Factor 1; <sup>2</sup> Factor 2; \* excluded

### **E.3. Motivated Strategies for Learning Questionnaire scale, adapted from Pintrich et al. (1991) (Chapter 5)**

#### *Time and study environment management*

I attended class regularly.\* [Not at all true of me (1) – Very true of me (7)]

I usually studied in a place where I could concentrate on my PEAP course work.\*

I made good use of my study time for PEAP.

I found it hard to stick to a study schedule. (REVERSED)

I had a regular place set aside for studying.\*

I made sure that I kept up with the homework and assignments for my PEAP class.\*

I found that I didn't spend as much time studying English as I had planned because of other activities or demands. (REVERSED)

I rarely found time to review past lessons. (REVERSED)

\*items included in final analysis

#### *Effort regulation*

I often felt so lazy or bored when I studied for PEAP that I quit before I finish what I planned to do. (REVERSED)

I worked hard to do well in PEAP even if I didn't like what we were doing.

When course work was difficult, I gave up, or only studied the easy parts. (REVERSED)

Even when the homework and assignments were dull and uninteresting, I managed to keep working until I finish.

#### *Peer learning*

When studying for PEAP, I often found myself trying to explain the material to a classmate or a friend.

I tried to work with other students from this class to complete the homework or assignments.

When working on assignments for PEAP, I often devoted time to discuss the material with a group of other PEAP students.

#### *Help-seeking*

Even if I had trouble learning the material in this class, I tried to do the work alone, without help from anyone. (REVERSED)

I asked the teacher to re-explain parts of the lesson that I didn't understand very well.

When I couldn't understand the material, I asked another student for help.

I tried to identify students in my PEAP class whom I could ask for help if I needed it.

#### **E.4. Network name generators (Chapter 5)**

##### *Core discussion network* (Burt, 1984)

In the past two weeks, with whom have you talked about things that are important to you?

##### *Assignment details network*

"With whom have you talked about the details of either your final essay or final presentation? 'Details' could include the specific topic, the sources (books, articles, websites) that you use, the structure of your assignment, etc.

##### *Liking network*

How close do you feel to [name of classmate]?

##### *Helping network*

How much has [name of classmate] helped you with coursework in Block 4?

How much have you tried to help [name of classmate] with course-work in Block 4?

## References

- Abu-Rabia, S. (1996). Factors affecting the learning of English as a second language in Israel. *The Journal of Social Psychology, 136*(5), 589-595.
- Adler, P. S., & Kwon, S.-W. (2002). Social capital: Prospects for a new concept. *The Academy of Management Review, 27*(1), 17-40.
- Ajzen, I. (2005). *Attitudes, personality and behavior* (2nd ed.). Maidenhead: Open University.
- Alba, R. D. (1973). A graph-theoretic definition of a sociometric clique. *Journal of Mathematical Sociology, 3*, 113-126.
- Baker, S. C., & MacIntyre, P. D. (2000). The role of gender and immersion in communication and second language orientations. *Language Learning, 50*(2), 311-341.
- Bandura, A. (1997). *Self-efficacy: The exercise of control*. New York: W. H. Freeman and Company.
- Bandura, A. (2001). Social cognitive theory: An agentic perspective. *Annual Review of Psychology, 52*, 1-26.
- Barabási, A.-L., & Albert, R. (1999). Emergence of scaling in random networks. *Science, 286*(5439), 509-512.
- Bavelas, A. (1950). Communication patterns in task-oriented groups. *Journal of the Acoustic Society of America, 22*, 725-730.
- Becker, M. H. (1970). Factors affecting diffusion of innovations among health professionals. *American Journal of Public Health and the Nation's Health, 60*(2), 294-304.
- Beckner, C., Blythe, R., Bybee, J., Christiansen, M. H., Croft, W., Ellis, N. C., et al. (2009). Language is a complex dynamic system: Position paper. *Language Learning, 59*(s1), 1-26.

- Berger, C. R., & Calabrese, R. (1975). Some explorations in initial interaction and beyond: Toward a developmental theory of interpersonal communication. *Human Communication Research*, 99-112.
- Berger, P. L., & Luckmann, T. (1966). *The social construction of reality; A treatise in the sociology of knowledge*. Garden City, NY: Anchor Books.
- Bernard, H. R., Killworth, P. D., Kronenfeld, D., & Sailer, L. (1984). The problem of informant accuracy: The validity of retrospective data. *Annual Review of Anthropology*, 13, 495-517.
- Berry, J. W. (1997). Immigration, acculturation, and adaptation. *Applied Psychology: An International Review*, 46(1), 5-68.
- Blau, P. M. (1964). *Exchange and power in social life*. New York: John Wiley.
- Blau, P. M. (1977). *Inequality and heterogeneity: A primitive theory of social structure*. New York: Free Press.
- Block, D. (2003). *The social turn in second language acquisition*. Edinburgh: Edinburgh University Press.
- Bonacich, P. (1972). Factoring and weighting approaches to status scores and clique identification. *Journal of Mathematical Sociology*, 2, 113-120.
- Borgatti, S. P. (2005). Centrality and network flow. *Social Networks*, 27, 55-71.
- Borgatti, S. P., & Cross, R. (2003). A relational view of information seeking and learning in social networks. *Management Science*, 49(4), 432-445.
- Borgatti, S. P., & Everett, M. G. (1989). The class of all regular equivalences: Algebraic structure and computation. *Social Networks*, 11, 65-88.

- Borgatti, S. P., & Everett, M. G. (1992a). Notions of position in social network analysis. *Sociological Methodology*, 22, 1-35.
- Borgatti, S. P., & Everett, M. G. (1992b). Two algorithms for computing regular equivalence. *Social Networks*, 15, 361-376.
- Borgatti, S. P., & Everett, M. G. (2006). A graph-theoretic perspective on centrality. *Social Networks*, 28(4), 466-484.
- Borgatti, S. P., & Foster, P. C. (2003). The network paradigm in organizational research: A review and typology. *Journal of Management*, 29(6), 991–1013.
- Borgatti, S. P., Carley, K. M., & Krackhardt, D. (2006). On the robustness of centrality measures under conditions of imperfect data. *Social Networks*, 28(2), 124-136.
- Borgatti, S. P., Everett, M. G., & Freeman, L. C. (2002). *Ucinet for Windows: Software for Social Network Analysis*. Harvard, MA: Analytic Technologies.
- Borgatti, S. P., Mehra, A., Brass, D. J., & Labianca, G. (2009). Network analysis in the social sciences. *Science*, 323(5916), pp. 892-895.
- Bortoni-Ricardo, S. M. (1985). *The urbanization of rural dialect speakers: A sociolinguistic study in Brazil*. Cambridge: Cambridge University Press.
- Bott, E. (1957). *Family and social network: Norms and external relationships in ordinary urban families*. London: Tavistock Publishing.
- Brass, D. J., & Burkhardt, M. E. (1993). Potential power and power use: An investigation of structure and behavior. *Academy of Management Journal*, 36(3), 441-470.

- Bronfenbrenner, U. (1993). The ecology of cognitive development: research models and fugitive findings. In *Development in context: Acting and thinking in specific environments* (pp. 3-44). Hillsdale, NJ: Lawrence Erlbaum.
- Burgoon, J. K. (1976). The unwillingness-to-communicate scale: Development and validation. *Communication Monographs, 43*, 60-69.
- Burgoon, J. K., & Hubbard, A. S. (2005). Cross-cultural and intercultural applications of expectancy violations theory and interaction adaptation theory. In W. B. Gudykunst (Ed.), *Theorizing about intercultural communication* (pp. 149-172). London: Sage.
- Buriel, R., Perez, W., DeMent, T. L., Chavez, D. V., & Moran, V. R. (1998). The relationship of language brokering to academic performance, biculturalism, and self-efficacy among Latino adolescents. *Hispanic Journal of Behavioral Sciences, 20*(3), 283-295.
- Burt, R. S. (1976). Positions in networks. *Social Forces, 55*(1), 93-122.
- Burt, R. S. (1980). Models of network structure. *Annual Review of Sociology, 6*, 79-141.
- Burt, R. S. (1984). Network items and the General Social Survey. *Social Networks, 6*, 293-339.
- Burt, R. S. (1987). Social contagion and innovation: Cohesion versus structural equivalence. *The American Journal of Sociology, 92*(6), 1287-1335.
- Burt, R. S. (1992). *Structural holes: The social structure of competition*. Cambridge, MA: Harvard UP.
- Burt, R. S., Jannotta, J. E., & Mahoney, J. T. (1998). Personality correlates of structural holes. *Social Networks, 20*, 63-87.
- Cameron, L., & Larsen-Freeman, D. (2007). Complex systems and applied linguistics. *International Journal of Applied Linguistics, 17*(2), 226-240.

- Canale, M., & Swain, M. (1980). Theoretical bases of communicative approaches to second language teaching and testing. *Applied Linguistics*, 1, 1-47.
- Cao, Y. (2009). An ecological view of situational willingness to communicate in a second language classroom. In H. Chen, & K. Cruickshank (Eds.), *Making a difference: Challenges for applied linguistics* (pp. 199-218). Newcastle: Cambridge Scholar Press.
- Cao, Y., & Philp, J. (2006). Interactional context and willingness to communicate: A comparison of behavior in whole class, group and dyadic interaction. *System*, 34(4), 480-493.
- Cartwright, D., & Harary, F. (1956). Structural balance: A generalization of Heider's theory. *Psychological Review*, 63(5), 277-293.
- Celce-Murcia, M., Dörnyei, Z., & Thurrell, S. (1995). Communicative competence: A pedagogically motivated model with content specifications. *Issues in Applied Linguistics*, 6(2), 5-35.
- Cenoz, J., & Valencia, J. F. (1993). Ethnolinguistic vitality, social networks and motivation in second language acquisition: Some data from the Basque Country. *Language, Culture and Curriculum*, 6(2), 113-127.
- Chataway, C. J., & Berry, J. W. (1989). Acculturation experiences, appraisal, coping, and adaptation: A comparison of Hong Kong Chinese, French, and English students in Canada. *Canadian Journal of Behavioural Science*, 21(3), 295-309.
- Chen, J. F., Warden, C. A., & Chang, H. (2005). Motivators that do not motivate: The case of Chinese EFL learner and the influence of culture on motivation. *TESOL Quarterly*, 39(4), 609-633.
- Cheshire, J. (1982). Linguistic variation and social function. In S. Romaine (Ed.), *Sociolinguistic variation in speech communities* (pp. 153-166). London: Edward Arnold.



- Clément, R. (1980). Ethnicity, contact, and communicative competence in a second language. In H. Giles, W. P. Robinson, & P. M. Smith (Eds.), *Language: Social psychological perspectives* (pp. 147-154). Oxford: Pergamon Press.
- Clément, R. (1986). Second language proficiency and acculturation: An investigation of the effects of language status and individual characteristics. *Journal of Language and Social Psychology*, 5(4), 271-289.
- Clément, R., & Kruidenier, B. G. (1985). Aptitude, attitude and motivation in second language proficiency: A test of Clément's model. *Journal of Language and Social Psychology*, 4, 21-37.
- Clément, R., Baker, S. B., & MacIntyre, P. D. (2003). Willingness to communicate in a second language: The effects of context, norms, and vitality. *Journal of Language and Social Psychology*, 22(2), 190-209.
- Coleman, J. S. (1988). Social capital in the creation of human capital. *The American Journal of Sociology*, 94(Supplement: Organizations and Institutions: Sociological and Economic Approaches to the Analysis of Social Structure), S95-S120.
- Collentine, J., & Freed, B. F. (2004). Learning context and its effects on second language acquisition. *Studies in Second Language Acquisition*, 26, 153-171.
- Cook, K. S., & Whitmeyer, J. S. (1992). Two approaches to social structure: Exchange theory and network analysis. *Annual Review of Sociology*, 18, 109-127.
- Cook, K. S., Emerson, R. M., & Gillmore, M. R. (1983). The distribution of power in exchange networks: Theory and experimental. *The American Journal of Sociology*, 275-305.
- Costenbader, E., & Valente, T. W. (2003). The stability of centrality measures when networks are samples. *Social Networks*, 25, 283-307.

- Crick, N. R., & Dodge, K. A. (1994). A review and reformulations of social information-processing mechanisms in children's social adjustment. *Psychological Bulletin*, *115*(1), 74-101.
- Crookes, G., & Schmidt, R. W. (1991). Motivation: Reopening the research agenda. *Language Learning*, *41*(4), 469-512.
- Cropanzano, R., & Mitchell, M. S. (2005). Social exchange theory: An interdisciplinary review. *Journal of Management*, *31*, 874-900.
- D'Andrade, R. G. (1981). The cultural part of cognition. *Cognitive Science*, *5*, 179-195.
- de Bot, K., & Stoessel, S. (2002). Introduction: Language change and social networks. *International Journal of the Sociology of Language*(1-7), 153.
- de Bot, K., Lowie, W., & Verspoor, M. (2007). A dynamic systems theory approach to second language acquisition. *Bilingualism: Language and Cognition*, *10*(1), 7-21.
- Deci, E. L., & Ryan, R. M. (1985). *Intrinsic motivation and self-determination in human behavior*. London: Plenum.
- Deci, E. L., & Ryan, R. M. (2000). The "what" and "why" of goal pursuits: Human needs and the self-determination of behavior. *Psychological Inquiry*, *11*(4), 227-268.
- DeLongis, A., Folkman, S., & Lazarus, R. S. (1988). The impact of daily stress on health and mood: Psychological and social resources as mediators. *Journal of Personality and Social Psychology*, *54*(3), 486-495.
- Dickinson, L. (1995). Autonomy and motivation: A literature review. *System*, *23*(2), 165-174.
- Donovan, L. A., & MacIntyre, P. D. (2005). Age and sex differences in willingness to communicate, communication apprehension, and self-perceived competence. *Communication Research Reports*, *21*, 420-427.

- Dörnyei, Z. (1994). Motivation and motivating in the foreign language classroom. *The Modern Language Journal*, 78(3), 273-284.
- Dörnyei, Z. (2000). Motivation in action: Towards a process-oriented conceptualisation of student motivation. *British Journal of Educational Psychology*, 70, 519-538.
- Dörnyei, Z. (2002). The motivational basis of language learning tasks. In P. Robinson (Ed.), *Individual difference in second language acquisition* (pp. 137-158). Amsterdam: John Benjamins.
- Dörnyei, Z. (2007). *Research methods in applied linguistics: Qualitative, quantitative and mixed methodologies*. Mahwah, NJ: Lawrence Erlbaum.
- Dörnyei, Z. (2009a). Individual differences: Interplay of learner characteristics and learning environment. *Language Learning*, 59(SUPP1), 230–248.
- Dörnyei, Z. (2009b). The L2 motivational self system. In Z. Dörnyei, & E. Ushioda (Eds.), *Motivation, language identity and the L2 self* (pp. 9-42). Bristol: Multilingual Matters.
- Dörnyei, Z. (2011). *Teaching and researching motivation* (2nd ed.). Harlow: Pearson Education.
- Dörnyei, Z., & Kormos, J. (2000). The role of individual and social variables in oral task performance. *Language Teaching Research*, 4(3), 275-300.
- Dörnyei, Z., & Ottó, I. (1998). Motivation in action: A process model of L2 motivation. *Working Papers in Applied Linguistics (Thames Valley University, London)*, 4, 43-69.
- Dörnyei, Z., Csizér, K., & Németh, N. (2006). *Motivation, language attitudes and globalisation: A Hungarian perspective*. Clevedon: Multilingual Matters.
- Dörnyei, Z., Durow, V., & Zahran, K. (2004). Individual differences and their effect on formulaic sequence acquisition. In N. Schmitt (Ed.), *Formulaic sequences* (pp. 87-106). Amsterdam: John Benjamins.

- Eckert, P. (2000). *Linguistic variation as social practice*. Oxford: Blackwell.
- Edwards, W. F. (1992). Sociolinguistic behavior in a Detroit inner-city neighborhood. *Language in Society*, 21(1), 93-115.
- Ehrman, M. E., & Dörnyei, Z. (1998). *Interpersonal dynamics in second language education*. London: Sage.
- Ellis, N. C. (2006). Cognitive perspectives on SLA: The associative-cognitive CREED. *AILA Review*, 19, 100-121.
- Emerson, R. M. (1962). Power-dependence relations. *American Sociological Review*, 27(1), 31-41.
- Emerson, R. M. (1976). Social exchange theory. *Annual Review of Sociology*, 2, 335-362.
- Emirbayer, J., & Goodwin, J. (1994). Network analysis, culture, and the problem of agency. *American Journal of Sociology*, 99(6), 1411-1454.
- Erickson, B. H. (1988). The relational basis of attitudes. In B. Wellman, & S. D. Berkowitz (Eds.), *Social structures: a network approach* (pp. 99-122). Cambridge: Cambridge UP.
- Ferenz, O. (2005). EFL writers' social networks: Impact on advanced academic literacy development. *Journal of English for Academic Purposes*, 4, 229-351.
- Festinger, L. (1954). A theory of social comparison processes. *Human Relations*, 7(2), 117-140.
- Feuerstein, R. (1980). *Instrumental Enrichment: And Intervention Program for Cognitive Modifiability*. Baltimore: University Park Press.
- Firth, A., & Wagner, J. (1997). On discourse, communication, and (some) fundamental concepts in SLA research. *The Modern Language Journal*, 81(3), 285-300.

- Firth, A., & Wagner, J. (2007). Second/foreign language learning as a social accomplishment: Elaborations of a reconceptualized SLA. *The Modern Language Journal, 91*, Focus Issue: SLA, 800-819.
- Fishbein, M., & Ajzen, I. (1975). *Belief, attitude, intention, and behavior: An introduction to theory and research*. Reading, MA: Addison-Wesley.
- Folkman, S., Lazarus, R. S., Gruen, R. J., & DeLongis, A. (1986). Appraisal, coping, health status, and psychological symptoms. *Journal of Personality and Social Psychology, 50*(3), 571-579.
- Freeman, L. C. (1979). Centrality in social networks conceptual clarification. *Social Networks, 1*(3), 215-239.
- Freeman, L. C. (2004). *The development of social network analysis: A study in the sociology of science*. Vancouver: Empirical Press.
- Freeman, L. C., & Romney, A. K. (1987). Words, deeds and social structure: A preliminary study of the reliability of informants. *Human Organization, 46*(4), 330-334.
- Freeman, L. C., Borgatti, S. P., & White, D. R. (1991). Centrality in valued graphs: A measure of betweenness based on network flow. *Social Networks, 13*, 141-154.
- Freeman, L. C., Romney, A. K., & Freeman, S. C. (1987). Cognitive structure and informant accuracy. *American Anthropologist, 89*, 310-325.
- Friedkin, N. E. (1991). Theoretical foundations for centrality measures. *The American Journal of Sociology, 96*(6), 1478-1504.
- Friedkin, N. E. (1993). Structural bases of interpersonal influence in groups: A longitudinal case study. *American Sociological Review, 58*(6), 861-872.
- Friedkin, N. E. (2004). Social cohesion. *Annual Review of Sociology, 30*, 409-425.

- Friedkin, N. E., & Johnsen, E. C. (1999). Social influence networks and opinion change. *Advances in Group Processes, 16*, 1-29.
- Funder, D. C. (2001). Personality. *Annual Review of Psychology, 52*, 197-221.
- Funder, D. C. (2006). Towards a resolution of the personality triad: Persons, situations, and behaviors. *Journal of Research in Personality, 40*, 21-34.
- Gal, S. (1978). Peasant men can't get wives: Language change and sex roles in a bilingual community. *Language in Society, 7*(1), 1-16.
- Galaskiewicz, J. (1991). Estimating point centrality using different network sampling techniques. *Social Networks, 13*, 347-386.
- Galaskiewicz, J., & Wasserman, S. (1994). *Advances in social network analysis: Research in the social and behavioral science*. London: Sage.
- Gardner, R. C. (1985). *Social psychology and second language learning: The role of attitudes and motivation*. London: Edward Arnold.
- Gardner, R. C., & MacIntyre, P. D. (1991). An instrumental motivation in language study. *Studies in Second Language Acquisition, 13*, 57-72.
- Garson, G. D. (2009). Structural equation modeling. *Statnotes: Topics in multivariate analysis*, Retrieved 01/24/2010 from <<http://faculty.chass.ncsu.edu/garson/pa765/statnote.htm>>.
- Gass, S. M. (1997). *Input, Interaction, and the Second Language Learner*. Mahwah, NJ: Lawrence Erlbaum.
- Gibson, J. J. (1986). *The ecological approach to visual perception*. Hillsdale, NJ: Lawrence Erlbaum.

- Giddens, A. (1979). *Central problems in social theory: Action, structure and contradiction in social analysis*. London: The Macmillan Press, Ltd.
- Giles, H., & Byrne, J. L. (1982). The intergroup model of second language acquisition. *Journal of Multilingual and Multicultural Development*, 3, 17-40.
- Giles, H., Bourhis, R. Y., & Taylor, D. M. (1977). Towards a theory of language in ethnic group relations. In H. Giles, & J. L. Byrne (Eds.), *Language, ethnicity, and intergroup Relations* (pp. 307-348). New York: Academic Press.
- Goldberg, L. R. (1993). The structure of phenotypic personality traits. *American Psychologist*, 48(1), 26-34.
- Good, P. I. (2000). *Permutation tests: A practical guide to resampling methods for testing hypotheses*. New York: Springer.
- Granovetter, M. S. (1973). The strength of weak ties. *The American Journal of Sociology*, 78(6), 1360-1380.
- Granovetter, M. S. (1985). Economic action and social structure: The problem of embeddedness. *American Journal of Sociology*, 91(3), 481-510.
- Gudykunst, W. B. (2005a). An anxiety/uncertainty management (AUM) theory of effective communication: Making the net of the mesh finer. In W. B. Gudykunst, C. M. Lee, T. Nishida, & N. Ogawa (Eds.), *Theorizing about intercultural communication* (pp. 281-322). Thousand Oaks: Sage.
- Gudykunst, W. B. (2005b). An anxiety/uncertainty management (AUM) theory of strangers' intercultural adjustment. In W. B. Gudykunst, C. M. Lee, T. Nishida, & N. Ogawa (Eds.), *Theorizing about intercultural communication* (pp. 417-457). London: Sage.

- Gudykunst, W. B., & Hammer, M. R. (1988). Strangers and hosts: An uncertainty reduction based theory of intercultural adjustment. In W. B. Gudykunst, & Y. Y. Kim (Eds.), *Cross-cultural adaptation: Current approaches* (pp. 106-139). Newbury Park, CA: Sage.
- Gullahorn, J. E., & Gullahorn, J. T. (1966). American students abroad: Professional versus personal development. *Annals of the American Academy of Political and Social Science*, 368(1), 43-59.
- Hanneman, R. A., & Riddle, M. (2005). *Introduction to social network methods*. Riverside, CA: University of California, Riverside (published in digital form at <http://faculty.ucr.edu/~hanneman/>).
- Harary, F., Norman, R. Z., & Cartwright, D. (1965). *Structural models: An introduction to the theory of directed graphs*. New York: Wiley.
- Hashimoto, Y. (2002). Motivation and willingness to communicate as predictors of reported L2 use: The Japanese ESL context. *Second Language Studies*, 20(2), 29-70.
- Haslam, S. A. (2004). *Psychology in organizations: The social identity approach* (2nd ed.). London: Sage.
- Hayduk, L. (1987). *Structural equation modeling with LISREL*. Boston, MA: Johns Hopkins UP.
- Heider, F. (1946). Attitudes and cognitive organization. *Journal of Psychology*, 21, 107-112.
- Homans, C. G. (1961). *Social behavior: Its elementary forms*. New York: Harcourt, Brace & World.
- House, J. S. (1977). The three faces of social psychology. *Sociometry*, 40(2), 161-177.
- Hulsen, M., De Bot, K., & Weltens, B. (2002). Between two worlds: Social networks, language shift, and language processing in three generations of Dutch migrants in New Zealand. *International Journal of the Sociology of Language*, 153, 27-52.



- Hymes, D. (1972). On communicative competence. In J. B. Pride, & J. Holmes (Eds.), *Sociolinguistics: Selected readings* (pp. 269-293). Harmondsworth: Penguin.
- Hymes, D. (1974). *Foundations in sociolinguistics: An ethnographic approach*. Philadelphia: University of Pennsylvania Press.
- Isabelli-García, C. (2006). Study abroad social networks, motivation and attitudes: Implications for second language acquisition. In E. Churchill, & M. DuFon (Eds.), *Language learners in study abroad contexts* (pp. 231-258). Clevedon, UK: Multilingual Matters.
- Jones, E. E. (1998). Major developments in five decades of social psychology. In D. T. Gilbert, S. T. Fiske, & G. Lindzey (Eds.), *The handbook of social psychology* (4th ed., Vol. 1, pp. 3-57). New York: Oxford UP.
- Kadushin, C. (2002). The motivational foundation of social networks. *Social Networks*, 24(1), 77-91.
- Kang, S.-J. (2005). Dynamic emergence of situational willingness to communicate in a second language. *System*, 33(2), 277-292.
- Kanner, A. D., Coyne, J. C., Schaefer, C., & Lazarus, R. S. (1981). Comparison of two modes of stress management: Daily hassles and uplifts versus major life events. *Journal of Behavioral Medicine*, 4, 1-29.
- Kapferer, B. (1969). Norms and the manipulation of relationship in a work context. In J. C. Mitchell (Ed.), *Social networks in urban situations: Analyses of personal relationships in central African towns* (pp. 181-244). Manchester: Manchester UP.
- Kephart, W. M. (1950). A quantitative analysis of intragroup relationships. *American Journal of Sociology*, 55(6), 544-549.
- Kilduff, M., & Tsai, W. (2003). *Social networks and organizations*. London: Sage.

- Kim, Y. Y. (1988). *Communication and cross-cultural adaptation: An integrative theory of communication and cross-cultural adaptation*. Clevedon, UK: Multilingual Matters.
- Kim, Y. Y. (2001). *Becoming Intercultural: An Integrative Theory of Communication and Cross-cultural Adaptation*. Thousand Oaks, CA: Sage.
- Krackhardt, D. (1987). Cognitive social structures. *Social Networks*, 9, 109-134.
- Krackhardt, D. (1988). Predicting with networks: Nonparametric multiple regression analysis of dyadic data. *Social Networks*, 10, 359-381.
- Krackhardt, D., & Stern, R. N. (1988). Informal networks and organizational crises: An experimental simulation. *Social Psychology Quarterly*, 51(2), 123-140.
- Kurata, N. (2004). Communication networks of Japanese language learners in their home country. *Journal of Asian Pacific Communication*, 14(1), 153-178.
- Kurata, N. (2007). Language choice and second language learning opportunities in learners' social networks. A case study of an Australian learner of Japanese. *Australian Review of Applied Linguistics*, 30(1), 5.01-5.18.
- Kurata, N. (2011). *Foreign language learning and use: Interaction in informal social networks*. London: Continuum.
- Lambert, W. E. (1973). *Culture and language as factors in learning and education*. Paper presented at the Annual Learning Symposium on "Cultural Factors in Learning" .
- Langer, E. (1989). *Mindfulness*. Reading, MA: Addison Wesley.
- Langer, E. (2000). Mindfulness. *Current Directions in Psychological Science*, 9(6), 220-223.

- Lantolf, J. P., & Thorne, S. L. (2007). Sociocultural theory and second language learning. In B. VanPatten, & J. Williams (Eds.), *Theories in second language acquisition: An introduction*. Mahwah, NJ: Lawrence Erlbaum.
- Larsen-Freeman, D. (1997). Chaos/complexity science and second language acquisition. *Applied Linguistics*, 18(1), 141-165.
- Larsen-Freeman, D. (2007a). Reflecting on the cognitive-social debate in second language acquisition. *The Modern Language Journal*, 91, 773-787.
- Larsen-Freeman, D. (2007b). On the complementarity of Chaos/Complexity Theory and Dynamic System Theory in understanding the second language acquisition process. *Bilingualism: Language and Cognition*, 10(1), 35-37.
- Laumann, E. O., Marsden, P. V., & Prensky, D. (1989). The boundary specification problem in network analysis. In L. C. Freeman, D. R. White, & A. K. Romney (Eds.), *Research methods in social network analysis* (pp. 61-88). New Brunswick, NJ: Transaction Publishers.
- Lave, J., & Wenger, E. (1991). *Situated learning: Legitimate peripheral participation*. Cambridge: Cambridge UP.
- Lazarus, R. S., & Folkman, S. (1984). *Stress, appraisal and coping*. New York: Springer.
- Leavitt, H. J. (1951). Some effects of certain communication patterns on group performance. *Journal of Abnormal and Social Psychology*, 46(1), 38-50.
- Leifer, E. M., & Rajah, V. (2000). Getting observations: Strategic ambiguities in social interaction. *Soziale Systeme*, 6, 251-267.

- Lemyre, L., & Tessier, R. (1988). Mesure de stress psychologique (MSP): Se sentir stressé-e [Psychological stress measure (PSM): Feeling stressed]. *Canadian Journal of Behavioural Science, 20*, 302-321.
- Levine, J. M., & Moreland, R. L. (1990). Progress in small group research. *Annual Review of Psychology, 41*, 585-634.
- Lewin, K. (1948). *Resolving social conflicts: Selected papers on group dynamics*. New York: Harper & Bros.
- Li Wei. (1996). Network analysis. In H. Goebel, P. H. Nelde, & Z. Stary (Eds.), *Contact linguistics: An international handbook of contemporary research* (pp. 805-811). Berlin: Walter de Gruyter & Co.
- Lin, N. (2001). *Social capital: A theory of social structure and action*. Cambridge: Cambridge UP.
- Lippi-Green, R. L. (1989). Social network integration and language change in progress in a rural alpine village. *Language in Society, 18*(2), 213-234.
- Liska, A. E. (1984). A critical examination of the causal structure of the Fishbein/Ajzen attitude-behavior model. *Social Psychology Quarterly, 47*(1), 61-74.
- Long, M. H. (1981). Input, interaction, and second-language acquisition. *Annals of the New York Academy of Sciences, 379*, 259-278.
- Long, M. H. (1996). The role of the linguistic environment in second language acquisition. In W. C. Ritchie, & T. K. Bhatia (Eds.), *Handbook of second language acquisition* (pp. 413-468). San Diego: Academic Press.
- Lorrain, F. P., & White, H. C. (1971). Structural equivalence of individuals in social networks. *Journal of Mathematical Sociology, 1*, 49-80.

- Luce, R. D., & Perry, A. (1949). A method of matrix analysis of group structure. *Psychometrika*, *14*, 94-116.
- Luke, D. A., & Harris, J. K. (2007). Network analysis in public health: History, methods, and applications. *Annual Review of Public Health*, *28*, 69-93.
- MacDonald, J. R., Clément, R., & MacIntyre, P. D. (2003). *Willingness to communicate in a L2 in a bilingual context: A qualitative investigation of Anglophone and Francophone students*. Unpublished Manuscript.
- MacIntyre, P. D. (1994). Variables underlying willingness to communicate: A causal analysis. *Communication Research Reports*, *11*(2), 135-142.
- MacIntyre, P. D. (2007). Willingness to communicate in the second language: Understanding the decision to speak as a volitional process. *Modern Language Journal*, *91*, 564-576.
- MacIntyre, P. D., & Charos, C. (1996). Personality, attitude, and affect as predictors of second language communication. *Journal of Language and Social Psychology*, *15*, 3-18.
- MacIntyre, P. D., & Legatto, J. J. (2010). A dynamic system approach to willingness to communicate: Developing an idiodynamic method to capture rapidly changing affect. *Applied Linguistics*, Advance Access published October 20, 2010, 1-24.
- MacIntyre, P. D., Babin, P. A., & Clément, R. (1999). Willingness to communicate: Antecedents and consequences. *Communication Quarterly*, *47*(2), 215-229.
- MacIntyre, P. D., Baker, S. C., Clément, R., & Conrod, S. (2001). Willingness to communicate, social support, and language learning orientations of immersion students. *Studies in Second Language Acquisition*, *23*, 369-388.

- MacIntyre, P. D., Baker, S. C., Clément, R., & Donovan, L. A. (2002). Sex and age effects on willingness to communicate, anxiety, perceived competence, and motivation among junior high school French immersion students. *Language Learning, 52*, 537-564.
- MacIntyre, P. D., Baker, S. C., Clément, R., & Donovan, L. A. (2003). Talking in order to learn: Willingness to communicate and intensive language programs. *The Canadian Modern Language Review, 59*, 587-605.
- MacIntyre, P. D., Baker, S., Clément, R., & Conrod, S. (2001). Willingness to communicate, social support and language learning orientations of immersion students. *Studies in Second Language Acquisition, 23*, 369-388.
- MacIntyre, P. D., Clément, R., Dörnyei, Z., & Noels, K. A. (1998). Conceptualising willingness to communicate in a L2: A situational model of L2 confidence and affiliation. *Modern Language Journal, 82*, 545-562.
- Malecki, C. K., & Demaray, M. K. (2003). What type of support do they need? Investigating student adjustment as related to emotional, informational, appraisal, and instrumental support. *School Psychology Quarterly, 18*(3), 231-252.
- Marsden, P. V. (1987). Core discussion networks of Americans. *American Sociological Review, 52*(1), 122-131.
- Marsden, P. V. (1990). Network data and measurement. *Annual Review of Sociology, 16*, 435-463.
- Marsden, P. V., & Friedkin, N. E. (1994). Network studies of social influence. In J. Galaskiewicz, & S. Wasserman (Eds.), *Advances in social network analysis: Research in the social and behavioral sciences* (pp. 3-25). London: Sage.

- Masgoret, A. M., & Gardner, R. C. (1999). A causal model of Spanish immigrant adaptation in Canada. *Journal of Multilingual and Multicultural Development, 20*(3), 216-236.
- McAdam, D., & Paulsen, R. (1993). Specifying the relationship between social ties and activism. *The American Journal of Sociology, 99*(3), 640-667.
- McCroskey, J. C. (1992). Reliability and validity of the willingness to communicate scale. *Communication Quarterly, 40*, 16-25.
- McCroskey, J. C., & Baer, E. J. (1985). Willingness to communicate: The construct and its measurement. *Paper presented at the Annual Meeting of the Speech Communication Association*. Denver, CO.
- McCroskey, J. C., & Richmond, V. P. (1987). Willingness to communicate. In J. C. McCroskey, & J. A. Daly (Eds.), *Personality and interpersonal communication* (pp. 129-156). Newbury Park, CA: Sage.
- McCroskey, J. C., & Richmond, V. P. (1990a). Willingness to communicate: A cognitive view. *Journal of Social Behavior and Personality, 5*, 19-37.
- McCroskey, J. C., & Richmond, V. P. (1990b). Willingness to communicate: Differing cultural perspectives. *The Southern Communication Journal, 56*, 72-77.
- McPherson, M., Smith-Lovin, L., & Brashears, M. E. (2006). Social isolation in America: Changes in core discussion networks over two decades. *American Sociological Review, 71*(3), 353-375.
- McPherson, M., Smith-Lovin, L., & Cook, J. M. (2001). Birds of a feather: Homophily in social networks. *Annual Review of Sociology, 27*, 415-444.
- Merton, R. K. (1957). The role-set: Problems in sociological theory. *The British Journal of Sociology, 8*(2), 106-120.

- Milardo, R. M. (1988). *Families and social networks*. Newbury Park, CA: Sage.
- Milgram, S. (1967). The small-world problem. *Psychology Today*, 1(1), 61-67.
- Milroy, J., & Milroy, L. (1978). Belfast: Change and variation in an urban vernacular. In P. Trudgill (ed.), *Sociolinguistic patterns in British English* (pp. 19-36). London: Edward Arnold.
- Milroy, L. (1987). *Language and social networks*. Oxford: Basil Blackwell Ltd.
- Milroy, L., & Gordon, M. (2003). *Sociolinguistics: Method and interpretation*. Oxford: Blackwell.
- Milroy, L., & Li Wei. (1995). A social network approach to code-switching: The example of a bilingual community in Britain. In L. Milroy, & P. Muysken (Eds.), *One speaker, two languages* (pp. 136-157). Cambridge: Cambridge UP.
- Milroy, L., & Margrain, S. (1980). Vernacular language loyalty and social network. *Language in Society*, 9(1), 43-70.
- Mischel, W., & Shoda, Y. (1995). A cognitive-affective system theory of personality: Reconceptualizing situations, dispositions, dynamics, and invariance in personality structure. *Psychological Review*, 102(2), 246-268.
- Mitchell, J. C. (1969). The concept and use of social networks. In J. C. Mitchell (Ed.), *Social networks in urban situations: Analyses of personal relationships in central African towns* (pp. 1-50). Manchester: Manchester UP.
- Mizruchi, M. S. (1994). Social network analysis: Recent Achievements and current controversies. *Acta Sociologica*, 37, 329-343.
- Moreno, J. L. (1953). *Who shall survive? Foundations of sociometry, group psychotherapy, and sociodrama* (2nd ed.). Beacon, NY: Beacon House.



- Newman, M. E., & Park, J. (2003). Why social networks are different from other types of networks. *Physical Review E*, 68(3), 1-9.
- Nicassio, P. M., Solomon, G. S., Guest, S. S., & McCullough, J. E. (1986). Emigration stress and language proficiency as correlates of depression in a sample of Southeast Asian refugees. *International Journal of Social Psychiatry*, 32(1), 22-28.
- Noels, K. A., & Clément, R. (1996). Communicating across cultures: Social determinants and acculturative consequences. *Canadian Journal of Behavioural Science*, 28, 214-228.
- Norton, B. (2000). *Identity and language learning: Gender, ethnicity and educational change*. Harlow: Pearson.
- Oberg, K. (1960). Culture shock: Adjustment to new cultural environments. *Practical Anthropology*, 7, 177-182.
- Oller, K., Baca, L., & Vigil, F. (1977). Attitudes and attained proficiency in ESL: A sociolinguistic study of Mexican Americans in the Southwest. *TESOL Quarterly*, 11(2), 48-58.
- Oxford, R., & Shearin, J. (1994). Language learning motivation: Expanding the theoretical framework. *Modern Language Journal*, 78(1), 12-28.
- Palfreyman, D. (2006). Social context and resources for language learning. *System*, 34, 352-370.
- Passy, F. (2002). Social networks matter. But how? In M. Diani, & D. McAdam (Eds.), *Social movement analysis: The network perspective* (pp. 21-48). Oxford: Oxford UP.
- Pavlenko, A. (2002). Poststructuralist approaches to the study of social factors. In V. J. Cook (Ed.), *Portraits of the L2 User* (pp. 251-274). Clevedon: Multilingual Matters.
- Peng, J. E. (2007). Willingness to communicate in the Chinese EFL classroom: A cultural perspective. In J. Liu (Ed.), *English Language Teaching in China* (pp. 250-269). London: Continuum.

- Peng, J. E., & Woodrow, L. (2010). Willingness to communicate in English: A model in the Chinese EFL classroom context. *Language Learning, 60*(4), 834-876.
- Pescosolido, A. T. (2002). Emergent leaders as managers of group emotion. *The Leadership Quarterly, 13*(5), 583-599.
- Pintrich, P. R., & DeGroot, E. V. (1990). Motivational and self-regulated learning components of classroom academic performance. *Journal of Educational Psychology, 82*(1), 33-40.
- Pintrich, P. R., Smith, D. A., Garcia, T., & McKeachie, W. J. (1991). *A manual for the use of the motivated learning strategies questionnaire (MSLQ)*. Ann Arbor, MI: National Center for Research to Improve Postsecondary Teaching and Learning.
- Portes, A. (1998). Social capital: Its origins and applications in modern sociology. *Annual Review of Sociology, 24*, 1-24.
- Putnam, R. D. (2000). *Bowling alone: The collapse and revival of American community*. New York: Simon & Schuster.
- Radcliffe-Brown, A. R. (1940). On social structure. *Journal of the Royal Anthropological Society of Great Britain and Ireland, 70*, 1-12.
- Radcliffe-Brown, A. R. (1952). *Structure and function in primitive society: Essays and addresses*. London: Cohen & West.
- Raschka, C., Li Wei, & Lee, S. (2002). Bilingual development and social networks of British-born Chinese children. *International Journal of the Sociology of Language, 153*, 9-25.
- Richmond, V. P., & Roach, K. D. (1992). Willingness to communicate and employee success in U.S. organizations. *Journal of Applied Communication Research, 20*(1), 95-115.

- Robins, G. L., & Kashima, Y. (2008). Social psychology and social networks: Individuals and social systems. *Asian Journal of Social Psychology, 11*, 1-12.
- Robins, G., Pattison, P., Kalish, Y., & Lusher, D. (2007). An introduction to exponential random graph (p\*) models for social networks. *Social Networks, 29*(2), 173-191.
- Rubinfeld, S., Clément, R., Vinograd, J., Lussier, D., Amireault, V., Auger, R., et al. (2007). Becoming a cultural intermediary: A further social corollary of second-language learning. *Journal of Language and Social Psychology, 26*(2), 182-203.
- Russell, J. (1982). Networks and sociolinguistic variation in an African urban setting. In S. Romaine (Ed.), *Sociolinguistic variation in speech communities* (pp. 125-140). London: Edward Arnold.
- Salancik, G. R., & Pfeffer, J. (1977). Who gets power - and how they hold on to it: A strategic-contingency model of power. *Organizational Dynamics, 5*, 3-21.
- Salancik, G. R., & Pfeffer, J. (1978). A social information processing approach to job attitudes and task design. *Administrative Science Quarterly, 23*, 224-253.
- Sawada, M. (2009, November 23). *Global spatial autocorrelation indices - Moran's I, Geary's C and the general cross-product statistic*. Retrieved April 18, 2011, from University of Ottawa: Laboratory for Paleoclimatology and Climatology:  
[www.lpc.uottawa.ca/publications/moransi/moran.htm](http://www.lpc.uottawa.ca/publications/moransi/moran.htm)
- Schieffelin, B. B., & Ochs, E. (1986). Language socialization. *Annual Review of Anthropology, 15*, 163-191.
- Schmidt, R. (1990). The role of consciousness in second language learning. *Applied Linguistics, 11*, 129-158.

- Schumann, J. H. (1986). Research on the acculturation model for second language acquisition. *Journal of Multilingual and Multicultural Development, 7*(5), 379-392.
- Searle, J. R. (1995). *The social construction of reality*. London: Penguin Books.
- Shanker, S. G., & King, B. J. (2002). The emergence of a new paradigm in ape language research. *Behavioral and Brain Sciences, 25*, 605-620.
- Shaw, M. E. (1954). Group structure and the behavior of individuals in small groups. *The Journal of Psychology, 38*, 139-149.
- Simmel, G. (1908/1950). The stranger. In *The sociology of Georg Simmel* (K. H. Wolff, Trans., pp. 402-6). New York: Free Press.
- Simon, H. A. (1990). Invariants of human behavior. *Annual Review of Psychology, 41*, 1-19.
- Smith, L. R. (2002). The social architecture of communicative competence: A methodology for social-network research in sociolinguistics. *International Journal of the Sociology of Language, 153*, 133-160.
- Snijders, T. A., Steglich, C. E., & van de Bunt, G. G. (2010). Introduction to actor-based models for network dynamics. *Social Networks, 32*, 44-60.
- Stephenson, K., & Zelen, M. (1989). Rethinking centrality: Methods and examples. *Social Networks, 11*, 1-37.
- Stryker, S. (1977). Developments in "two social psychologies": Toward an appreciation of mutual relevance. *Sociometry, 40*(2), 145-160.
- Tajfel, H. (1978). *Differentiation between social groups*. London: Academic Press.
- Thibaut, J. W., & Kelley, H. H. (1959). *The social psychology of groups*. New York: Wiley.

- Thompson, N. S., & Valsiner, J. (2002). Doesn't a dance require dancers? *Behavioral and Brain Sciences*, 25, 641-642.
- Tomasello, M., & Rakoczy, H. (2003). What makes human cognition unique? From individual to shared to collective intentionality. *Mind & Language*, 18(2), 121-147.
- Tomasello, M., Carpenter, M., Call, J., Behne, T., & Moll, H. (2005). Understanding and sharing intentions: The origins of cultural cognitions. *Behavioral and Brain Sciences*, 1-17.
- Tse, L. (1995). Language brokering among Latino adolescents: Prevalence, attitudes, and school performance. *Hispanic Journal of Behavioral Sciences*, 17, 180-193.
- Turner, J. C. (1981). Towards a cognitive redefinition of the social group. In H. Tajfel (Ed.), *Social identity and intergroup relations* (pp. 15-40). Cambridge: Cambridge UP.
- United Kingdom Committee for International Student Affairs (UKCISA). (2010). *Higher education statistics*. Retrieved 03/16/2010 from <[http://ukcisa.org.uk/about/statistics\\_he/php](http://ukcisa.org.uk/about/statistics_he/php)>.
- Ushioda, E. (2009). A person-in-context relational view of emergent motivation, self and identity. In Z. Dörnyei, & E. Ushioda (Eds.), *Motivation, language identity and the L2 self* (pp. 215-228). Bristol: Multilingual Matters.
- van der Gaag, M. P., Snijders, T. A., & Flap, H. D. (2008). Position generator measures and their relationship to other social capital measures. In N. Lin, & B. Erickson (Eds.), *Social capital: An international research program* (pp. 27-48). Oxford: Oxford UP.
- van der Gaag, M., & Snijders, T. A. (2005). The resource generator: Social capital quantification with concrete items. *Social Networks*, 27(1), 1-29.
- van der Poel, M. G. (1993). Delineating personal support networks. *Social Networks*, 15, 49-70.
- van Dongen, S. (2000). *Graph clustering by flow simulation (PhD Thesis)*. University of Utrecht.

- van Lier, L. (2000). From input to affordance: Social-interactive learning from an ecological perspective. In J. P. Lantolf (Ed.), *Sociocultural theory and second language learning* (pp. 245-260). Oxford: Oxford UP.
- van Lier, L. (2004). *The ecology and semiotics of language learning: A sociocultural perspective*. Bosteon: Kluwer Academic Publishers.
- Walker, J., Wasserman, S., & Wellman, B. (1994). Statistical models for social support networks. In S. Wasserman, & Galaskiewicz (Eds.), *Advances in social network analysis* (pp. 53-78). Thousand Oaks, CA: Sage.
- Ward, C. A., & Kennedy, A. (1993). Psychological and socio-cultural adjustment during cross-cultural transitions: A comparison of secondary students overseas and at home. *International Journal of Psychology*, 28(2), 129-147.
- Wasserman, S., & Faust, K. (1994). *Social network analysis: Methods and applications*. Cambridge: Cambridge UP.
- Waxman, P. (2000). The impact of English language proficiency on the adjustment of recently arrived Iraqi, Bosnian, and Afghan refugees in Sydney. *Prospect*, 15(1), 4-22.
- Weber, M. (1947). *The theory of social and economic organization*. (A. Henderson, & T. Parsons, Trans.) New York: The Free Press.
- Wellman, B. (1988). Structural analysis: From method and metaphor to theory and substance. In B. Wellman, & S. D. Berkowitz (Eds.), *Social structures: A network approach* (pp. 19-61). Cambridge: Cambridge UP.
- Wen, W. P., & Clément, R. (2003). A Chinese conceptualisation of willingness to communicate in ESL. *Language, Culture and Curriculum*, 16(1), 18-38.

- Wheeldon, P. D. (1969). The operation of voluntary associations and personal networks in the political processes of an inter-ethnic community. In J. C. Mitchell (Ed.), *Social networks in urban situations: Analyses of personal relationships in central African towns*. Manchester: Manchester UP.
- White, H. C., Boorman, S. A., & Breiger, R. L. (1976). Social structure from multiple networks. I. Blockmodels of roles and positions. *American Journal of Sociology*, *81*(4), 730-780.
- Wiklund, I. (2002). Social networks from a sociolinguistic perspective: The relationship between characteristics of the social networks of bilingual adolescents and their language proficiency. *International Journal of the Sociology of Language*, *153*, 53-92.
- Williams, M., & Burden, R. L. (1997). *Psychology for Language Teachers*. Cambridge: Cambridge UP.
- Winship, C., & Mandel, M. (1983). Roles and positions: A critique and extension of the blockmodeling approach. *Sociological Methodology*, *14*, 314-344.
- Yashima, T. (2002). Willingness to communicate in L2: The Japanese EFL context. *Modern Language Journal*, *86*, 54-66.
- Yashima, T., & Zenuk-Nishide, L. (2008). The impact of learning contexts on proficiency, attitudes, and L2 communication: Creating an imagined international community. *System*, *36*(4), 566-585.
- Yashima, T., Zenuk-Nishide, L., & Shimizu, K. (2004). Influence of attitudes and affect on L2 communication: A study of Japanese high school students. *Language Learning*, *54*(1), 119-152.
- Ying, Y. W. (2005). Variation in acculturative stressors over time: A study of Taiwanese students in the United States. *International Journal of Intercultural Relations*, *29*, 59-71.

Ying, Y. W., & Liese, L. H. (1991). Emotional well-being of Taiwan students in the U.S.: An examination of pre- to post-arrival differential. *International Journal of Intercultural Relations, 15*(3), 345-366.