

Prociów, Paweł (2011) Mobile psychiatry: Personalised Ambient Monitoring for the mentally ill. PhD thesis, University of Nottingham.

Access from the University of Nottingham repository:

http://eprints.nottingham.ac.uk/12152/1/Full_final.pdf

Copyright and reuse:

The Nottingham ePrints service makes this work by researchers of the University of Nottingham available open access under the following conditions.

- Copyright and all moral rights to the version of the paper presented here belong to the individual author(s) and/or other copyright owners.
- To the extent reasonable and practicable the material made available in Nottingham ePrints has been checked for eligibility before being made available.
- Copies of full items can be used for personal research or study, educational, or not-for-profit purposes without prior permission or charge provided that the authors, title and full bibliographic details are credited, a hyperlink and/or URL is given for the original metadata page and the content is not changed in any way.
- Quotations or similar reproductions must be sufficiently acknowledged.

Please see our full end user licence at:

http://eprints.nottingham.ac.uk/end_user_agreement.pdf

A note on versions:

The version presented here may differ from the published version or from the version of record. If you wish to cite this item you are advised to consult the publisher's version. Please see the repository url above for details on accessing the published version and note that access may require a subscription.

For more information, please contact eprints@nottingham.ac.uk

**Mobile psychiatry:
Personalised Ambient Monitoring
for the mentally ill**

by

Paweł Prociów, MSc

Thesis submitted to the University of Nottingham for the degree of

Doctor of Philosophy

December 2011



Abstract

Mental health has long been a neglected problem in global healthcare. The social and economic impacts of conditions affecting the mind are still underestimated. However, in recent years it is becoming more apparent that mental disorders are a growing global concern that is not to be trivialised. Considering the rising burden of psychiatric illnesses, there is a necessity of developing novel services and researching effective means of providing interventions to sufferers. Such novel services could include technology-based solutions already used in other healthcare applications but are yet to make their way into standard psychiatric practice.

This thesis presents a study on how pervasive technology can be utilised to devise an “early warning” system for patients with bipolar disorder. The system, containing wearable and environmental sensors, would collect behavioural data and use it to inform the user about subtle changes that might indicate an upcoming episode. To test the feasibility of the concept a prototype system was devised, which was followed by trials including four healthy volunteers as well as a bipolar patient. The system included a number of sensory inputs including: accelerometer, light sensors, microphones, GPS tracking and motion detectors.

The experiences from the trials led to a conclusion that a large number of sensors may result in incompletion from the users. Therefore, a separate investigation was launched into developing a methodology for detecting behavioural patterns in inputs possible to collect from a mobile phone alone. The premise being that a phone is an everyday use appliance and is likely to be carried and accepted by the patient. The trial revealed that monitoring GPS tracks and Bluetooth encounters has the potential of gaining an insight into a person’s social and behavioural patterns, which usually are strongly influenced by the course of bipolar disorder.

Lessons learned during these proceedings amounted to a clearer concept of how a future personalised ambient monitoring system could improve the outcome of treatment of bipolar disorder as well as other psychiatric conditions.

Publications from this thesis

The following papers and conference presentations were based on parts of this work:

James, C.J. et al., 2009. Personalised Ambient Monitoring (PAM) of the mentally ill. In J. Sloten et al., eds. *4th European Conference of the International Federation for Medical and Biological Engineering*. Antwerp: Springer Berlin Heidelberg, pp. 1010-1013-1013.

Prociow, P. & Crowe, J A, 2009. Sensors enhancing self-monitoring for people with bipolar disorder. *5th IEEE EMBS UK & Republic of Ireland Postgraduate Conference on Biomedical Engineering and Medical Physics*, pp.50-52.

Prociow, P.A. & Crowe, John A, 2010. Development of mobile psychiatry for bipolar disorder patients. *Conference proceedings : Annual International Conference of the IEEE Engineering in Medicine and Biology Society. IEEE Engineering in Medicine and Biology Society. Conference*, pp.5484-7.

Prociow, P.A. & Crowe, John A, 2010. Towards personalised ambient monitoring of mental health via mobile technologies. *Technology and health care : official journal of the European Society for Engineering and Medicine*, 18(4-5), pp.275-84.

Prociow, P.A. et al., 2009. Personalised Ambient Monitoring (PAM) for People with Bipolar Disorder. *Global Telemedicine and eHealth Updates: Knowledge Resources*, 2, pp.532-534.

Prociow, P.A., Wac, K. & Crowe, John A, 2010. Design of a Wearable System for Personalized Monitoring and Therapeutic Interventions in Bipolar Disorder. In *Therapeutic Strategies A Challenge for User Involvement in Design Workshop in conjunction with NORDICHI 2010*. pp. 46-50.

Acknowledgements

Firstly, I would like to thank all the people that directly contributed to this work: my supervisor professor John Crowe and colleagues from the PAM project. It is the numerous discussions, arguments and brainstorming sessions that made this thesis what it is. Secondly, I owe thanks to all the participants of all the studies described within. They happily endured through little annoyances of carrying electronic boxes, discharging phones etc. just to do their bit in the name of science.

On a more personal level, I would like to thank my parents as it is they, who inspired me to pursue opportunities that were never given to them. I also wish to thank all the friends I made in and out of the lab, especially Alina, Ania, Ed, Jeremy, Mario and Szczepan who made Nottingham feel a lot like my home away from home.

Last but definitely not least, I am grateful to the wonderful Magda who gladly joined me in Nottingham just to support me through the entire time of my PhD. I couldn't have done it without her.

Table of contents

ABSTRACT	2
PUBLICATIONS FROM THIS THESIS.....	3
ACKNOWLEDGEMENTS	4
TABLE OF CONTENTS	5
1 BACKGROUND.....	9
1.1 GROWING PROBLEM OF MENTAL DISORDERS.....	9
1.1.1 <i>Mental disorders in the European Union</i>	<i>11</i>
1.1.2 <i>Current psychiatric practice and new approaches.....</i>	<i>13</i>
1.1.3 <i>Research questions</i>	<i>14</i>
1.2 AMBULATORY MONITORING.....	15
1.2.1 <i>Handheld computer aided data collection.....</i>	<i>16</i>
1.2.2 <i>Ambulatory sensor networks.....</i>	<i>16</i>
1.3 RELEVANT CASE STUDIES.....	19
1.3.1 <i>Monitoring of the elderly.....</i>	<i>19</i>
1.3.2 <i>Handheld diaries</i>	<i>20</i>
1.3.3 <i>Incorporation of physiological measurements.....</i>	<i>20</i>
1.3.4 <i>Utilisation of actigraphy and other measures</i>	<i>23</i>
1.4 FOCUS ON BIPOLAR DISORDER.....	24
1.4.1 <i>Why Bipolar Disorder?</i>	<i>24</i>
1.4.2 <i>Overview of technology-based approaches to bipolar disorder.....</i>	<i>25</i>
1.5 SUMMARY	28
1.6 THE PAM APPROACH.....	29
2 THE CONCEPT OF PERSONALISED AMBIENT MONITORING (PAM).....	31

2.1	BIPOLAR DISORDER	31
2.1.1	<i>Mania and Hypomania</i>	32
2.1.2	<i>Depression</i>	33
2.1.3	<i>Diagnosis</i>	33
2.1.4	<i>Bipolar cycles</i>	34
2.1.5	<i>Triggers</i>	34
2.1.6	<i>Condition management</i>	35
2.2	SYSTEM CONCEPT AND ARCHITECTURE.....	36
2.2.1	<i>Sensory inputs</i>	40
2.2.2	<i>Middleware and communications link</i>	43
2.2.3	<i>Processing</i>	45
2.2.4	<i>Personalised feedback</i>	46
2.3	SUMMARY	47
3	IMPLEMENTATION OF PAM.....	49
3.1	WEARABLE SENSORS.....	50
3.1.1	<i>Position sensor</i>	52
3.1.2	<i>Custom Wearable Box (CWB)</i>	53
3.1.3	<i>Mobile phone</i>	64
3.2	ENVIRONMENTAL SENSORS	65
3.2.1	<i>PC computer and its role</i>	66
3.2.2	<i>Camera</i>	66
3.2.3	<i>Motion detectors</i>	68
3.2.4	<i>Custom environmental box (CEB) and system</i>	69
3.3	VALIDATION PROCEDURES	76
3.3.1	<i>The accelerometer</i>	76
3.3.2	<i>Light sensors</i>	76

3.3.3	<i>Microphones</i>	77
3.3.4	<i>Binary environmental sensors</i>	77
3.4	MOBILE PHONE SOFTWARE.....	78
3.4.1	<i>Platforms and APIs</i>	79
3.4.2	<i>Java Micro Edition and its constraints</i>	80
3.4.3	<i>Software Architecture</i>	81
3.4.4	<i>Sensor library</i>	83
3.4.5	<i>User interface</i>	83
3.5	FILE FORMATS.....	84
3.5.1	<i>Comma Separated Values (CSV) format</i>	84
3.5.2	<i>Extensible Mark-up Language (XML) file</i>	84
3.6	SUMMARY	86
4	TECHNOLOGY TRIALS	88
4.1	ETHICAL PROCEDURES	88
4.1.1	<i>Recruitment constraints</i>	89
4.2	TECHNICAL TRIAL	89
4.2.1	<i>Setup</i>	90
4.2.2	<i>Participants</i>	92
4.2.3	<i>Collected data</i>	92
4.2.4	<i>Post-trial overview of the objectives</i>	105
4.3	PATIENT TRIAL	108
4.3.1	<i>Recruitment and interviews</i>	109
4.3.2	<i>Deployment</i>	110
4.3.3	<i>Results</i>	110
4.4	SUMMARY	112
5	PHONE-BASED PAM	114

5.1	PREMISE	114
5.1.1	<i>Initial feedback on PAM</i>	114
5.1.2	<i>The concept of phone-based PAM</i>	115
5.2	PHONE SENSORS	115
5.2.1	<i>Positioning</i>	116
5.2.2	<i>Bluetooth encounters</i>	116
5.3	TRIAL	118
5.3.1	<i>Setup</i>	118
5.3.2	<i>Participants and ethical approval</i>	120
5.4	RESULTS AND ANALYSIS	120
5.4.1	<i>GPS tracks analysis</i>	121
5.4.2	<i>Inclusion of cell information</i>	132
5.4.3	<i>Bluetooth encounters</i>	136
5.4.4	<i>Change detection</i>	139
5.5	SUMMARY	141
6	DISCUSSION AND CONCLUSIONS	144
6.1	SUMMARY OF WORK	144
6.2	KEY CONCLUSIONS AND DISCUSSION	146
6.3	BARRIERS	149
6.4	THE FUTURE	151
6.4.1	<i>Elements</i>	151
6.4.2	<i>The general scheme</i>	153
	APPENDIX A. TRIAL RESULTS OF PAM ON PHONE	155
	APPENDIX B. THE PAM READING'S FILE	174
	REFERENCES	176

1 Background

Mental health has long been a neglected problem in global healthcare. The social and economic impacts of conditions affecting the mind are still underestimated, much as the problems of those who suffer from such illnesses were overlooked and their burden trivialised. However, in recent years it is becoming more apparent that mental disorders are a growing concern not only in the “developed world” but globally as well. Considering the rising burden of such conditions, researchers, in their reports, point to the necessity of developing novel services and researching non-costly and effective means of providing interventions to sufferers [1]. Such novel services could include technology-based solutions already used in healthcare as well as other non-medical human-centered applications.

The main scope of this chapter is to introduce the increasing burden of mental disorders and present examples of current state-of-the-art approaches that aim to tackle the plethora of mental conditions, each with its own specificity and issues which constitute the background to the work described in the thesis.

1.1 Growing problem of mental disorders

When considered in terms of mortality, mental disorders are not to be found among the main priorities of public health [2,3]. This is largely due to the fact that the vast majority of neuropsychiatric conditions (even if untreated) do not directly lead to the death of the patient. Nevertheless in extreme circumstances these illnesses can increase the risk of mortality (e.g. by suicide) [3]. However, using more complex measures of quality of life significantly changes the perspective. An example of such a measure is Disability Adjusted Life Years (DALY) that is widely used in reports and global health analysis [4]. DALY is the sum of the number of years of life lost due to premature death and years of life lived with

disability. Reports, utilising DALYs to calculate the burden of diseases, rank mental conditions almost as high as respiratory and cardiovascular conditions and higher than all types of cancer and HIV (Figure 1-1) [2,5].

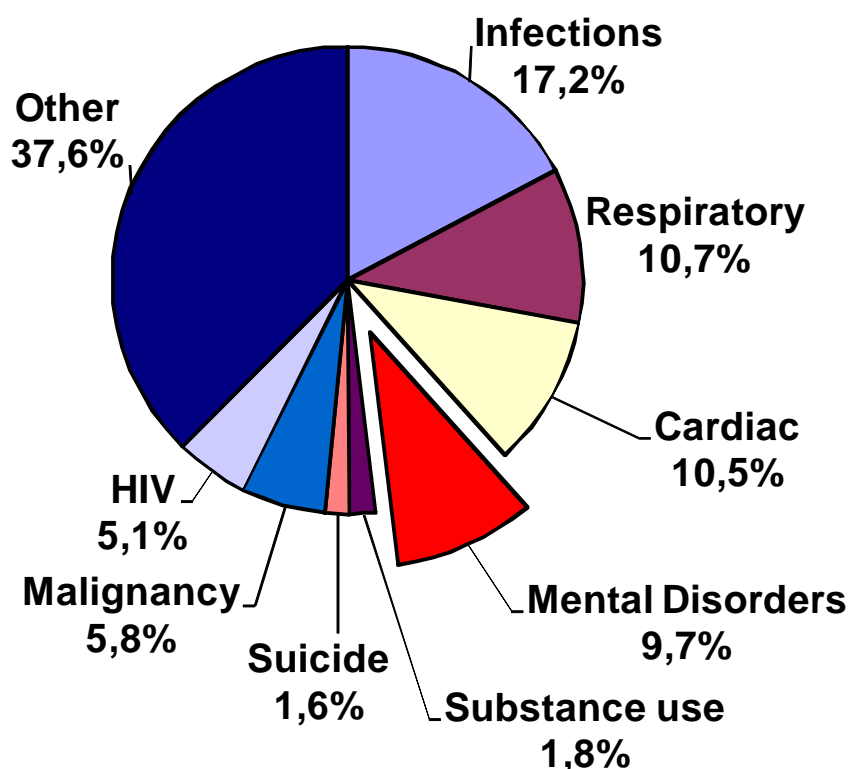

Figure 1-1 Global DALYs by cause [5]

Moreover, it is projected that by 2030 mental disorders will constitute 15% of the global disease burden with unipolar depression becoming the second highest occurring condition as shown in Table 1-1 [3].

Table 1-1 Top causes of burden in 2002 and projected in 2030 (source: Mathers and Loncar [6])

Disease or Injury	2002 Rank	2030 Ranks	Change in Rank
Perinatal conditions	1	5	-4
Lower respiratory infections	2	8	-6
HIV/AIDS	3	1	+2
Unipolar depressive disorders	4	2	+2
Diarrhoeal diseases	5	12	-7
Ischaemic heart disease	6	3	+3
Cerebrovascular disease	7	6	+1
Road traffic accidents	8	4	+4
Malaria	9	15	-6
Tuberculosis	10	25	-15
COPD	11	7	+4
Congenital anomalies	12	20	-8
Hearing loss, adult onset	13	9	+4
Cataracts	14	10	+4
Violence	15	13	+2
Self-inflicted injuries	17	14	+3
Diabetes mellitus	20	11	+9

1.1.1 Mental disorders in the European Union

As a rule, whether is it due to underdiagnosis or other factors, mental disorders are a more significant problem in high income countries – a group which includes all members of the EU [4,6]. According to numerous studies analysed by Wittchen and Jacobi it is estimated that about 27% of the current adult population of the EU is, or has been affected by at least one disorder from the mental spectrum during the last 12 months (Table 1-2) [1].

Table 1-2 Estimated prevalence of mental conditions in the EU [1]

Diagnosis	Estimated 12 month prevalence (millions)	Percentage of population
Alcohol dependence	7.2	2.4
Illicit substance dependence	2.0	0.7
Psychotic disorders	3.7	1.2
Major depression	18.4	6.1
Bipolar disorder	2.4	0.8
Panic disorder	5.3	1.8
Agoraphobia	4.0	1.3
Social phobia	6.7	2.2
Anxiety disorder	5.9	2
Specific phobias	18.5	6.1
Obsessive-compulsive disorder	2.7	0.9
Somatoform disorders	18.9	6.3
Eating disorders	1.2	0.4
Any mental disorder	82.7	27.4
Comorbidity		
Number of diagnoses:		
One	56.5	18.7
Two	15.0	5
Three or more	11.2	3.7

Out of this number only 26% of cases receive any consultation with healthcare services [1]. Furthermore, only about a third of those consultations were with mental health specialists with the remainder made in either primary care or other non-specialist health

services. In general, the consultation rate is higher in patients with mood disorders or cases with two or more disorders (comorbidity). This is shown in Table 1-3 along with the type of intervention resulting from the consultations. Almost a quarter of those do not result in any treatment whatsoever which may indicate a need for intermediate means of dealing with the problem. Therefore, it is even more significant for European healthcare systems to provide care for patients affected by psychiatric conditions by facilitating new approaches to their treatment and management.

Table 1-3 Type of treatment received by the users of health services [1]

	Any consultation	Proportion of treatment type after any consultation			
		Only drug	Only psych.	Drug and psych.	None
Any disorder	25.7 %	34.0 %	18.3 %	26.5 %	21.2 %
Any mood disorder	36.5 %	37.9 %	13.8 %	33.1 %	15.1 %
Any anxiety disorder	26.1 %	30.8 %	19.6 %	26.5 %	23.2 %
Any alcohol disorder	8.3 %	19.5 %	34.0 %	31.7 %	14.9 %
Only one disorder	19.6 %	34.3 %	19.4 %	17.2 %	29.1 %
More than one disorder	40.0 %	33.5 %	17.0 %	37.3%	12.1 %

1.1.2 Current psychiatric practice and new approaches

Currently, clinical psychiatry (and psychology) relies greatly on the retrospective self-reporting of patients' symptoms. Such methods of data collection, whether it is an end-of-day paper diary, simple interview or a structured questionnaire, have one common feature in that the information must be recalled from the patient's memory [7]. This may lead to misjudgement of the patient's state as studies show that gathering information retrospectively is subject to multiple systematic distortions and biases [8]. For example, it is

known that “positive” events are more likely to be remembered than ones with negative association for the respondent. The processing of memories is also connected to the current mood which introduces even more variability to the recollection process [9].

Considering the distortions and biases, researchers and clinicians have begun to introduce a different approach to rectify the disadvantages of the retrospective method. The methodologies range from the use of real-time electronic diaries, maintained by the user, to the use of sophisticated technology to extract psycho-physiological information independent of the user’s input [7]. Attempts to apply these methods of ambulatory assessment in clinical psychiatry could also be observed.

The following sections present current research regarding different aspects of real-time monitoring, including some psychiatric implementations. All of this constitutes the main context of the work presented in the following chapters.

1.1.3 Research questions

Despite the rapidly growing prevalence and burden of the psychiatric disorders the evolution of diagnostic and monitoring tools for psychiatry (and psychology) is slower in comparison to other fields of medicine. This is mainly due to the fact that mental symptoms are typically of subjective nature, hard to quantify using objective measures. However, facets of most behavioural conditions can possibly be appraised using recent ambulatory technology.

Therefore, from an engineering point of view, there are several key research questions to be tackled. The most fundamental of those is whether technology-based solutions truly augment the process of managing psychiatric disorders. If so, what means (i.e. sensors, electronic diaries etc.) could be utilised to achieve a significant improvement in care for

patients. Particular in the case of sensory systems, which inputs may play a key role in a support platform and which are impracticable in this research context.

In order to prepare the background for investigating these aspects, the following sections present current research regarding different areas of real-time monitoring, including the existing psychiatric implementations. All of this constitutes the main context of the work presented in the following chapters.

1.2 Ambulatory Monitoring

This section briefly discusses current work in research areas such as ambulatory assessment and activity monitoring using wireless networks.

Ambulatory assessment in healthcare means using a set of measures to detect even minimal disturbances in patients' patterns when performing normal activities in their usual environments. Tools used for this purpose range from simple pen-and-pencil checklists to handheld glucometers. Recent additions to this methodology are the sensors located on a patient's body designed to unobtrusively collect physiological data. This is a rapidly growing field with a plethora of applications and utilised sensors. The following sections provide only a brief overview of the research field, a comprehensive review of the area with a focus on psycho-physiological monitoring is provided elsewhere ([10], [11]). Ambulatory sensors lie at the core of current telecare networks able to unobtrusively collect clinically relevant patient data, process it and feed the results to appropriate receivers [12,13]. It is the rapid development of those fields that inspired the application of pervasive monitoring solutions in psychiatric practice.

1.2.1 Handheld computer aided data collection

The most basic way of collecting ambulatory data is to have the patients fill in an appropriate questionnaire during their usual daily activity. However, paper-based forms are being increasingly replaced with modern hand-held electronic devices. At first these were customised Personal Digital Assistants (PDA) [14] but now it is possible to enable ordinary mobile phones to perform regular questioning of the patient and provide a means of interventions for example via the use of text messaging [15].

In response to this surge of data collection technology several studies have been designed and executed to test the effect of replacing traditional methods of collecting user input. A comprehensive review by Lane *et al.* [16] render handheld computers as favourable over paper and pencil for data collection. Handheld computers appeared superior regarding the timeliness of receipt and data handling and are preferred by most subjects [16].

These improvements in the process of questionnaire data collection are more relevant to psychiatry and psychology than any other medical field with many voices supporting the use of handheld electronic means of momentary assessment over traditional methods [7,8]. The advantages of handheld electronic assessment include:

- Near real-time data collection
- Possible on-the-fly analysis of information and immediate response
- Possibility of applying data collection strategies e.g. event-enabled monitoring

1.2.2 Ambulatory sensor networks

Modern developments in sensor technology enable ambulatory assessment systems to collect far more than user inputs. Currently there is a wide range of sensing techniques used in health applications. For instance, measuring physical activity and posture. with the use of

accelerometers, step-counters, gyroscopes etc. For years, such means are widely utilised in studies dealing with specific tasks like appraising the progress of Parkinson's disease [17,18], Multiple Sclerosis [19,20], detecting falls [21,22] or even cough monitoring [23]. Moreover, actigraphy is also used for more general purposes, for example the estimation of energy expenditure and overall activity of the user [24]. This finds applications in researching the causes of obesity, stress and other syndromes that could be related to general physical activity.

Depending on the application, ambulatory monitoring systems also incorporate numerous sensors acquiring physiological data. One of the most extremely relevant physiological quantity is heart rate. The methodologies utilised for obtaining heart rate range from the most established electrocardiography (ECG) to pulse-oximetry or photoplethysmography depending on the additional type of physiological information desired from a patient [25]. Implementations of state-of-the-art ambulatory systems sometimes contain several other physiological inputs like electromyography (EMG), galvanic skin response (GSR), electroencephalography (EEG) [25]. As more research on ambulatory use of such inputs is done, more correlation between these quantities and patients' wellbeing are revealed.

Ambulatory sensors do not exclusively consist of wearable devices. Many implementations also include sensing the users' home environment which may influence their health as well as (in some cases) behaviour. In order to gain the clinically relevant information, these 'Smart Homes' use sensors for humidity, temperature and ambient sound as well as motion detectors, activity detecting cameras, light sensors and appliance usage monitors. Sometimes even simple sensors combined with appropriate processing may lead to a system able to recognise the current activity of the inhabitant [26].

However, ambient sensing often means a high degree of ambiguity in the collected data as it is hard to differentiate information for one subject in an environment if multiple individuals are present. To rectify this ambiguity, fusion between ambient and wearable sensor data is one of the main challenges for effective ambulatory monitoring [27]

Almost every behavioural disorder has its base in a patient's physiological mechanisms and biological events are important facets of many cognitive problems [28]. Changes in heart rate, blood pressure, cortisol levels and EEG profiles and others are often a definite indicator of numerous mental conditions [10]. Therefore, collecting momentary physiological data may appear to be a valid application of ambulatory technology. However, the main barrier to the wide application of physiological measurements in a real-life ambulatory setting is the cumbersomeness of collecting such data on a day-to-day basis. This renders ambulatory physiological sensors impracticable. A more suitable approach is to monitor patients' activity via actigraphy. Sources report a vast plethora of psychiatric disorders which relate to increased or decreased physical activity [29]. Examples include attention deficit disorder (ADHD), schizophrenia, major depression or manic episodes of bipolar disorder.

The importance of collecting sensor-based data in addition to traditional self-assessment reports is of particular importance in dealing with psychiatric and psychological conditions. Several studies showed that objective data collected via the use of activity or physiological measurements can differ greatly from the subjective perception of a self-reporting patient [30]. A particular example of this paradox in anxiety disorders is presented in sections containing case studies further in this chapter [31]. In general sources agree that while questionnaires are undoubtedly suitable as a method for studying subjective attitudes and representations of an experience, they cannot substitute for actual behavioural data coming from everyday observance [30].

1.3 Relevant case studies

This section discusses the specific applications of ambulatory methods in the fields of psychiatry and psychology. Features and solutions relevant for this body of work are highlighted. The examined topics include research on a wide range of disorders, from schizophrenia and dementia to anxiety and borderline personality disorders. Further examples of studies utilising psychophysiological momentary assessment can be found elsewhere ([10,32]).

1.3.1 Monitoring of the elderly

One of applications of ambulatory monitoring which is a key focal point for modern healthcare is the care for the elderly. The connection between providing services for this group with current problems of mental healthcare is strong as statistics show that approximately 5% percent of people over 65 are affected by dementia with this percentage increasing to 40% for the population over 90 [33].

An ambulatory system to assist the needs of older people has unique requirements compared to other health applications. Firstly, the location based services play a greater role in the process with systems incorporating location sensors, ranging from simple GPS based solutions to complex indoor ultrasound-based location technologies [34-37]. Location services are used to aid the user in the case of experiencing disorientation or to provide exact position to caregivers in the case of wandering or an accident. Additionally, the systems for elderly users often use actigraphy and physiological measurements to detect long periods of non-activity or falls as well as to monitor key vital signs [36,38].

What is relevant to the work described in this thesis are examples of utilising smartphones as “cognitive prosthetics” and sensorised environments facilitating the care for

elderly patients affected by dementia [39,40]. Systems aim to generate alerts when out-of-the-ordinary user activity (or lack of it) occurs [41]. Location and geospatial information is particularly important in the process. A similar methodology has the potential to be applied to the task of caring for patients with other more complex psychiatric impairments.

1.3.2 Handheld diaries

As stated, electronic handheld devices rapidly made their way into the field of ambulatory monitoring. One of the early examples of researching the utilisation of such technology in a psychiatric context was work by Herman and Koran [42] as well as Newman *et al.* [43]. In their implementations patients suffering from obsessive compulsive disorder (OCD) and panic disorder respectively were prompted hourly by a simple PDA to fill in an electronic version of one of the established assessment scales. Moreover the study by Newman *et al.* used the PDA to administer cognitive behaviour therapy [43]. The studies provided promising results as there was correlation between momentary assessment and traditional clinician-administered interviews. Among the main findings of these studies were issues which are equally valid currently. Firstly, the compliance rate was lower than expected as regular prompts had a negative effect on the participants. Secondly the authors mention the hardware platform (Casio PB 1000) becoming obsolete during the execution of the study which also influenced the outcome [42]. It should be noted that similar problems were to some extent encountered during the experimentation presented in this thesis.

1.3.3 Incorporation of physiological measurements

In their work on anxiety and panic disorders Wilhelm and Roth pointed to the fact that the majority of the diagnostic symptoms are of a physiological nature but in psychiatric practice they are assessed only by verbal report [31,44]. Therefore the authors proposed a set

of physiological measures which would provide objective data about matching symptoms (Table 1-4). This method of study preparation was also adapted in this work.

The experiments showed that there is a difference between the experiences described by patients and their physiological measures. This conclusion is common amongst other studies of this type [8]. It is worth noticing that Roth in his later work on physiological markers of phobias and anxiety still points out that physiological measurements were not incorporated into clinical practice [44].

Physiological measurements were also utilised in studies on psychiatric disorders. However, even in cases where a clear relationship is observed between a physiological marker and a particular disorder, the measure used may not be practicable in ongoing ambulatory observation. A good example of such is the use of EEG which can be related to some depressive syndromes [45].

Among others, cardiac measurements were most widely used in the investigations. In particular heart rate variability (HRV) was proven to be closely linked to the course of depressive and anxiety disorders [46,47]. This link, in particular, is responsible for the increased risk of heart failure in people with those conditions [47,48]. In relation to this coherence, initial studies have shown that external factors and social interactions in particular, can moderate the relationship between HRV and depressive mood [49]. This signals the need for a more general monitoring of a person's life to fully understand the course of a disorder (in this case depression).

Table 1-4 Associations between selected disorder syndromes and physiological measures in several conditions (source: Wilhelm and Roth [31])

Self-reported symptom	Physiological measure
<i>Panic Attack</i>	
Palpitations, pounding heart, or accelerated heart rate	stroke volume, pulse pressure, and/or heart rate, low frequency heart rate variability, ectopic beats
Sweating	skin conductance
Trembling or shaking	electromyographic activity
Sensations of shortness of breath or smothering	minute ventilation and/or peak inspiratory flow, inspiratory pause, respiratory resistance
Feeling of choking	??
Chest pain or discomfort	Electrocardiogram abnormalities, e.g. ST-segment depression, ectopic beats?, intercostal electromyographic activity?
Nausea or abdominal distress	electrogastrographic activity
Feeling dizzy, unsteady, lightheaded, or faint	vestibular abnormalities (e.g. in eye-tracking or vestibulo-oculo-reflex)
Paresthesias	peripheral blood flow
Chills or hot flushes	body surface temperature or blood flow
<i>Posttraumatic Stress Disorder</i>	
Exaggerated startle response	eye-blink startle response magnitude
Physiological hyperreactivity to trauma-relevant events	changes in several response systems
Motoric restlessness	electromyographic activity and/or limb movement
<i>Generalised Anxiety Disorder</i>	
Muscle tension	electromyographic activity
Restlessness	electromyographic activity and/or limb movement
Shortness of breath or smothering sensations	minute ventilation and/or inspiratory flow rate
Palpitations or accelerated heart rate	stroke volume and/or heart rate, low frequency heart rate variability, ectopic beats
Sweating, or cold clammy hands	skin conductance, body surface temperature or blood flow
Dry mouth	salivary flow rate
Dizziness or lightheadedness	vestibulo-oculo abnormalities by electrooculography
Nausea, diarrhea, or other abdominal distress	electrogastrographic activity
Flushes (hot flashes) or chills	body surface temperature or blood flow
Trouble swallowing or 'lump in throat'	electromyographic activity

1.3.4 Utilisation of actigraphy and other measures

There are several studies using measures of activity in ambulatory monitoring [30]. Obvious applications are in monitoring conditions where increased or decreased activity is one of the main symptoms (e.g. hyperactivity in cases of ADHD). A study by Boonstra *et al.* used actigraphy to validate the effectiveness of methylphenidate on adults with ADHD [50].

Monitoring of activity combined with ambulatory monitoring of heart rate was utilised by Ebner-Premier *et al.* in a study on emotion and cognitive deregulation in patients with borderline personality disorder. In this study activity measures were used to establish whether the detected change (usually an increase) in heart rate is an effect of physical activity or emotional reaction. Users were also subjected to momentary self-assessment in order to gain comparative data [51]. It is noteworthy that the ECG monitors used in this study were not worn on a day to day basis. Subjects were physiologically monitored for 24 hours in a one-off monitoring session. This was most likely due to the inconvenience of ambulatory ECG monitoring on a day to day basis.

A promising use of non-invasive methods as a biomarker for the occurrence of a particular psychiatric disorder can be found in the work by Rapcan *et al.* [52]. The main method used in this study on schizophrenia was voice analysis of patients diagnosed with this condition. The study showed that by using a certain set of acoustic features, mostly pause-related, the occurrence of syndromes of schizophrenia such as alogia (a slowing of speech and thoughts) could be detected [52]. A similar syndrome can be observed in patients with major depression. Features like the number of pauses, proportion of silence, variation of energy were successfully used to distinguish between schizophrenic patients and the control group.

Such direction for ambulatory monitoring of psychiatric disorders may prove to be most applicable as in this example there is no need for cumbersome physiological readings.

1.4 Focus on Bipolar Disorder

Examples of research on bipolar disorder (BD) were purposely omitted in previous sections and are discussed separately as it is the main focus point of this thesis. There are many reasons for this attention on BD in the context of technology aided care. This section discusses why BD is a suitable condition to test novel approaches to ambulatory monitoring of mental health. It discusses the current state-of-the-art research and briefly outlines the approach taken in this body of work and highlights the features distinguishing it from other implementations.

1.4.1 Why Bipolar Disorder?

Bipolar disorder is characterised by occurrences of depressive and manic episodes, each with its own specific outcomes. Often the episodes can directly follow each other. The occurrence of an episode results in major behavioural changes which are apparent in all areas of a patient's life [53]. The syndromes, course, types and current treatment regimes are discussed in-depth in the following chapter.

As shown earlier, BD is not the most widely spread psychiatric condition. However, reports show that, among mental illnesses, BD alongside schizophrenia has the highest "disability rating". This rating is directly proportional to the disability caused to the patient by the condition [3]. Therefore, developing novel means of managing the condition is a valid goal for modern health services.

The nature of the disorder due to which patients can experience the extremes of low mood and inactivity which then can swing to hyperactivity and grandiosity in the manic

phase, renders it an interesting and challenging problem to tackle using a means of pervasive computing. In summary, the main reasons which led to attempts of using ubiquitous computing methods in this work are as follows:

- There is a need for development of an “early warning system” against an episode as early recognition improves effectiveness of interventions [54].
- The occurrence of opposite extremes of behaviour, characterising the condition, is likely to be apparent in activity signatures possible to monitor pervasively.
- Unlike numerous psychiatric conditions patients with BD possess in general a high self-awareness and are willing to comply with treatment regimes [55].
- There is a known link between the condition and increased creativity which renders the patient group as more likely to accept novel approaches to the management regime [56,57].

These assumptions were at the core of the Pervasive Ambient Monitoring system which is described in detail in further chapters.

1.4.2 Overview of technology-based approaches to bipolar disorder

One of the first attempts of introducing technology in the context of managing BD was the ChronoRecord implemented in Germany by Whybrow and Bauer [58,59]. The main objective of the work was to evaluate the concept of self-monitoring via the use of PC-based software. The participating outpatients would use their own computers to enter data relevant to the course of the condition. These inputs were: mood rating, hours of sleep, medications taken, menstrual data, significant life events and weight. All of these inputs were self-assessed and no objective measures were taken into account. The results were very promising with high acceptability rates and proved to be as good as those achieved with clinician-administered traditional assessment scales. Among the gains of using the tool the

authors mention that the very act of self-recording improves patient's adherence to treatment regimes and medication. Further successful validation studies of the method proved that the use of technology may revolutionise the care for BD patients and encouraged further developments [59].

Another use of technology to monitor the course of BD is described by Bopp *et al.* In their work patients, in various stages of the bipolar cycle, were prompted via weekly text messages (or e-mail) to return their retrospective 7-day mood rating collected using one of the established self-assessment scales. The authors admit that weekly prompts do not fully tackle the problem of retrospective recall, whereas momentary assessment using such a methodology is unfeasible as frequent prompts would feel both intrusive and laborious [60]. This longitudinal study consisting of 36 weeks of monitoring achieved high compliance rates and demonstrated the potential of using mobile phones, an everyday appliance, in tackling the problem. The study however did not employ any sensory inputs which might provide objective validation of collected data.

A very recent project that proposes the use of physiological measurements is the PSYCHE project led by a private research company SMARTEX [61]. The project is in its initial stage but lists BD as one of the main potential applications [62]. In the proposed scheme the usefulness of physiological measurements like ECG, EMG or GSR will be evaluated. The system aims to combine these readings with speech analysis and environmental parameters. The authors intend to use smart textiles to achieve relatively unobtrusive measurements of physiological parameters. According to their latest publications, the first prototype of a sensory garment incorporating 3-axis accelerometers, single lead ECG and respiratory sensors are evaluated.

The most advanced work in the field of monitoring BD using technological means comes from research led by the Italian-based research centre CREATE-NET. Most recently it

initiated a pan-European project Monarca which aims to develop new ways of treatment and prediction of bipolar episodes [63].

In their work they first outlined the proposed architecture of a flexible platform called “The P³ platform” (Psychological Persuasive and Pervasive platform) which would process data coming from unobtrusive sensors distributed in patients’ environments and worn by them (see Figure 1-2) [64].

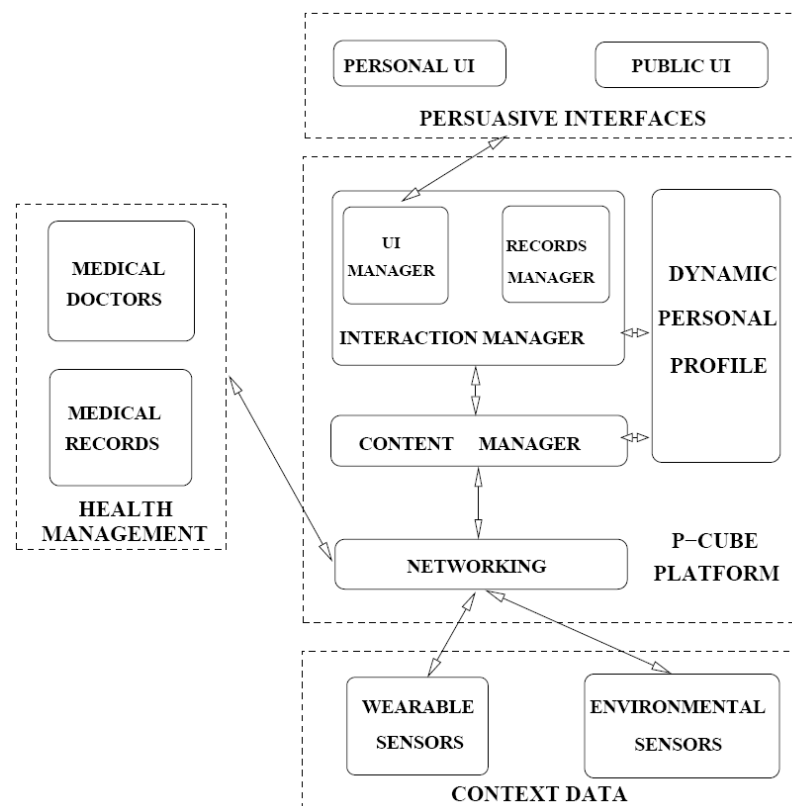

Figure 1-2 The P-cube platform architecture [64]

The initial reports discussing feasibility of pervasive solutions for BD do not name exact sensors to be used in the process but point to the possibility of using ECG, accelerometers, microphones and GSR sensor readings as potential “context data” in the above scheme [64].

The main concepts of this work constituted the base of the MONARCA project which was recently initiated. The basic framework of the project was announced in Sept. 2010. In

the proposed system the multimodal monitoring frontend consists of several sensory inputs which are to facilitate the monitoring of general activity as well as behavioural pattern analysis and emotional state recognition [63]. These are: GSR, ECG, EEG, microphones, accelerometers and location sensors [63,65]. The first two are to be embedded in a “smart sock” whereas acceleration and possibly other types of sensors will be contained in a wrist worn device [63].

In related work from the same research team, a methodology for sensing mood via the use of a mobile phone based platform was suggested [65]. The inference about a user’s social and behavioural patterns would be based on location, body movements and sound analysis, all of which could be acquired from a mobile phone. At the same time the users are to regularly self-assess their mood using well-established mood scales. Once all of these inputs are collected, the identified patterns could possibly be correlated with mood levels. This would enable the development of algorithms for deriving mood state [65]. Up to date the sensory system envisioned within the MONARCA project is under development and soon to be tested.

1.5 Summary

The analysis of current research in the area of ambulatory monitoring for mental health lead to a conclusion that technology-aided methods of collecting information about patients’ well-being are still not part of standard clinical practice in mental health. Despite the progress in ambulatory care including development of less obtrusive body worn sensors, such technology is yet to make its way into psychiatric treatment and monitoring regimes. This issue has been noticed in several publications [7,31]. However, attempts to include computerised self-assessment, physiological measurements, actigraphy and other novel

approaches in the field of psychiatry, can also be found. Examples include from simple PDA-implemented electronic diaries, to sophisticated algorithms targeting particular symptoms of a condition [52]. However, recent years brought about research in complex systems with a flexible architecture and including several psychophysiological measures. Moreover, patients affected by BD were identified as a group that is most likely to benefit from such a holistic and novel approach. Therefore the development of a complete support platform for people affected by this condition is the core of the project presented in this thesis.

1.6 The PAM approach

This thesis was conducted as part of the Personalised Ambient Monitoring (PAM) project funded by EPSRC (under grant EP/F003714/1) and devised by the Universities of Nottingham, Southampton and Stirling. The main goal of the project, which pre-dates the PSYCHE and MONARCA projects described in this Chapter, was to test the feasibility of novel approaches to mental care [66]. Devising a possible architecture, development of a prototype sensor frontend as well as initial experimentation are the main objectives for the research presented in this thesis. The research was also supported by an advisory group consisting of clinicians, patients, nurses as well as representatives of healthcare-related institutions and companies including the NHS.

Considering the current research background described in this chapter, several conclusions were drawn that affected the design and evaluation of the prototype. Although physiological measurements such as ECG, EEG, GSR can provide useful data which can be related to many behavioural syndromes, ambulatory monitoring of those signals is likely to be challenging on a day to day basis. Basing on the initial input from psychiatrists and other

researchers and considering the specificity of the target group, there are reasons to believe that any system incorporating such measures would not be complied with. Moreover, such technology requires a certain amount of user care (e.g. during putting ECG electrodes) which might be highly affected by an onset of either BD episode. Therefore, a more promising approach is to use the less cumbersome actigraphy and focus on data that it is possible to collect via the use of simple sensors and everyday-use devices like mobile phones. Such an approach occupies the middle ground between the biased and sometimes subjective data collection based on self reports and the inconvenience of physiological measurements.

2 The concept of Personalised Ambient Monitoring (PAM)

This chapter introduces the main idea of Personalised Ambient Monitoring for people with BD. The initial sections introduce a brief history of the condition, a description of its course and the main diagnostic criteria followed by a description of the currently used treatments, management and monitoring regimes.

The remaining sections present how the pervasive technology can be utilised to possibly improve the wellbeing of the patients and their quality of life. An increasing demand for such systems is due to the growing prevalence of the condition. The attempts to match ambulatory monitoring technology with the key areas affected by the disorder are made and put in the context of an entire support network whose possible structure is also outlined.

2.1 Bipolar disorder

BD, formerly known as manic-depression, is a condition that has been recognised for centuries. The first descriptions of severe manic and depressive behaviour were described by the ancient Greeks. However, the distinction between ‘manic-depressive insanity’ and other forms of psychosis (e.g. schizophrenia) was made in the, relatively recent, second half of the 19th century. The true emphasis on the bipolarity of the condition arose from research performed by Perris which was made public in the early 1960s [67] where it was observed that many patients demonstrate periods of euphoric behaviour that are often followed by times of melancholy (now called depression).

The condition is now widely recognised and diagnosed. Studies estimate that the two main distinguished types of the disorder affect from 1 to 2 % of the European and the US

population, whereas a further 6% could be affected by a condition from a wider bipolar range [68,69]

The most widely used guidelines for diagnosing BD are formalized in the Diagnostic and Statistical Manual of Mental Disorders fourth edition (DSM-IV). It provides guidelines to aid the diagnosis of states of mania, hypomania and major depression. All of these are relevant in diagnosing disorders from the bipolar spectrum.

2.1.1 Mania and Hypomania

According to the DSM guidelines, mania is diagnosed when an abnormally and persistently elevated and irritable mood is either present for more than a week or renders the patient in need of hospitalisation. The symptoms which usually accompany the elevated mood are [70]:

- Inflated self-esteem and feelings of grandiosity.
- Decreased need of sleep (self-deprivation of rest).
- Talkativeness, pressure to keep talking.
- Flight of ideas and racing thoughts.
- Distractibility, attention easily drawn away from tasks
- Increased goal oriented activity
- Psychomotor agitation
- Excessive involvement in pleasurable activities

If the above syndromes are not severe enough to cause functional impairment of the patient, then such state is called hypomania. It sometimes preludes a case of full manic behaviour but may also be the only sign of elevated mood in a BD patient. The distinction between the two is the key to diagnose the particular types of BD described in further

sections. The patient often views hypomania as a desirable state which is often omitted in interviews which may lead to misdiagnosis of BD as an unipolar depression [71].

2.1.2 Depression

Analogically to mania, a major depressive episode is diagnosed when at least five of the following symptoms recur every day (or nearly every day) over a period of two weeks and constitutes a significant change from the previous state [70].

- Depressed mood most of the day
- Diminished interest in most activities, lack of pleasure
- Significant weight change, decrease or increase in appetite
- Insomnia or in some cases hypersomnia
- Psychomotor retardation
- Fatigue or loss of energy
- Feelings of worthlessness or inappropriate guilt
- Problems concentrating, indecisiveness
- Recurrent thoughts of death, suicidal urges

These are the key areas influenced by an onset of a major depression. Statistically some features (e.g. hypersomnia and psychomotor retardation) are more common in bipolar disorder than in a unipolar depression [72].

2.1.3 Diagnosis

DSM-IV defines two main types of bipolar disorder (I and II) which differ in the severity and length of manic episodes in the manic depressive course of the disorder. The third type - NOS (i.e. not otherwise specified) groups conditions that belong to the general bipolar spectrum but do not fit the definition of BD type I or II.

In general:

- Bipolar disorder type I is diagnosed when the patient experiences at least one episode of mania along with periods of major depression.
- Bipolar disorder type II is diagnosed when the patient experiences periods of hypomanic behaviour that do not become a full manic episode.

The successful recognition of manic behaviour and more subtle occurrence of a hypomania is crucial in the diagnosis of the disorder as bipolar. There are suggestions that bipolar disorder is under-diagnosed and classified as unipolar depression, which in many cases leads to overutilization of antidepressants. These can trigger an onset of a full-blown manic episode leading to serious consequences [71].

2.1.4 Bipolar cycles

Usually, bipolar episodes last weeks or months and recur several times in a lifetime. There is no rule defining the common length of a bipolar cycle [70]. Rapid cycling is diagnosed when the episodes occur more often than four times in a year [73]. According to studies this can apply to up to 20% of people affected by the disorder. Moreover, rapid cycling is known to disproportionately affect female sufferers by a factor of 3:1 [73]. Sources also distinguish ultra-rapid cycling where cycles occur within weeks or days, but there is no universally agreed definition of such a course of the condition [74].

2.1.5 Triggers

There are several triggers known to initiate a bipolar episode. The common case of prescribed antidepressants causing a manic episode was described in the previous paragraph [71]. Moreover, it is widely recognised that disruptions of sleep and circadian rhythms may cause an onset [75]. Sources recognise the tendency that the occurrence of major life events

can often cause the patient to experience an episode [76]. Studies also associate a stressful lifestyle and disruptions to social rhythms as contributors to a possible relapse of the condition [77]. Abuse of drugs and alcohol (among other consequences) can also have a negative influence on the bipolar cycle.

2.1.6 Condition management

Structured questionnaires are a common tool used in clinical practice to monitor the current patient state. There are several widely used assessment scales that were designed to appraise the extent of manic or depressive behaviour. Some are intended to be used by the clinician like Mood Disorder Questionnaire (MDQ), The Bech-Rafaelsen Mania and the Melancholia Rating Scale (MAS and MES), whereas others were made for self-appraisal (e.g. Zung Self-Rating Depression scale) [78].

Patients may also chart their overall mood creating a personalised mood calendar. This links to Cognitive Behaviour Therapy (CBT) that has proven effectiveness in managing BD [55]. The main premise of CBT is that thoughts and beliefs can exacerbate mood states which then cause functional impairment (Figure 2-1) and that by taking actions to rectify and change those thoughts and feelings the outcome behaviour and functioning can be improved [55].

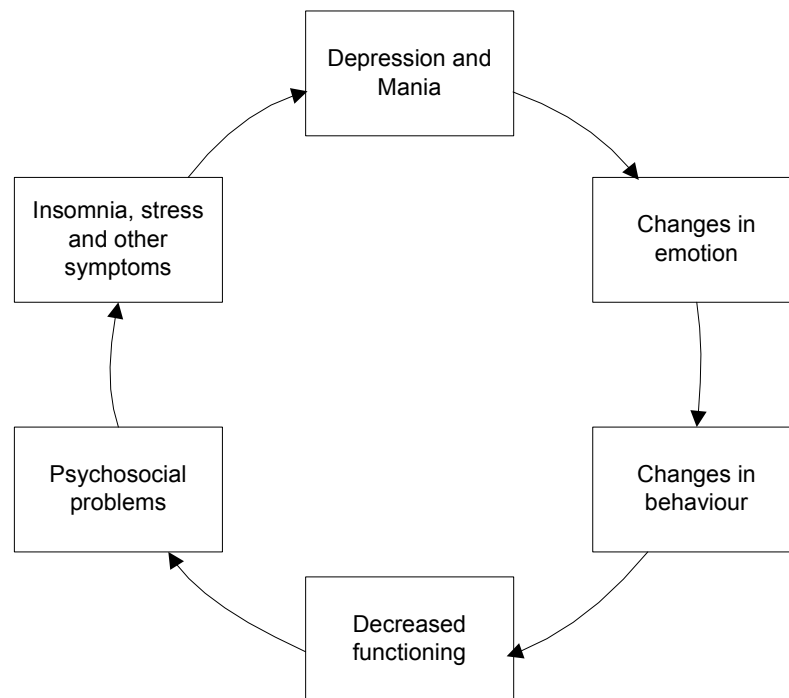

Figure 2-1 The cognitive model for the course of bipolar disorder (source: Ramirez, Basco [55]).

Whether it forms a part of either cognitive therapy or traditional treatment it has been proven that actions taken by the patient during an early stage of an episode can improve the quality of life and reduce the risk of losing self-control during an episode [54,79]. Therefore successful identification of prodromes (i.e. early signs of syndromes) would contribute significantly to any management regime.

2.2 System concept and architecture

The established practice of assessing the patient’s wellbeing is to interview the patient regularly. The cooperation with the clinician and well developed self awareness of the person affected by the condition is key to maintaining the desired mood stability. It is also generally agreed that keeping to a constant life routine is a major factor in dealing with the disorder. The areas of life likely to be affected by an onset of an episode can be monitored by pervasive technology. The main research question for a PAM system is whether

electronically aided observation could assist in recognising early signs or detect known triggers of an episode and prompt an intervention aimed at pre-empting an episode and its consequences.

There are several sub-layers in a PAM system facilitating the care for BD patients. Each of these layers poses separate research problems about practicability and feasibility of the proposed solutions. The work presented in this thesis was part of the PAM project grant also involving the Universities of Southampton and Stirling, with researchers from each of those institutions working on different aspects of the PAM system as described in this Chapter. This thesis covers the design and implementation of a sensor suite as specified in the following section. The scope also includes validating and testing the developed solutions in a real-life setting along with proposing initial data processing techniques. The process of setting the system in patients' homes as well as collecting the initial data from such tests is also described.

The following sections describe the concept of a technology-based system facilitating the process of self-monitoring, self-helping and alerting the support group, including the clinician when a serious change is detected. The user-centred system could provide a means of effective appraisal of a patient's current state using an independent set of sensory data. Modern smart phones with their capabilities and connectivity could be an appropriate hub for such an architecture. Figure 2-2 illustrates a simplified scheme for a PAM.

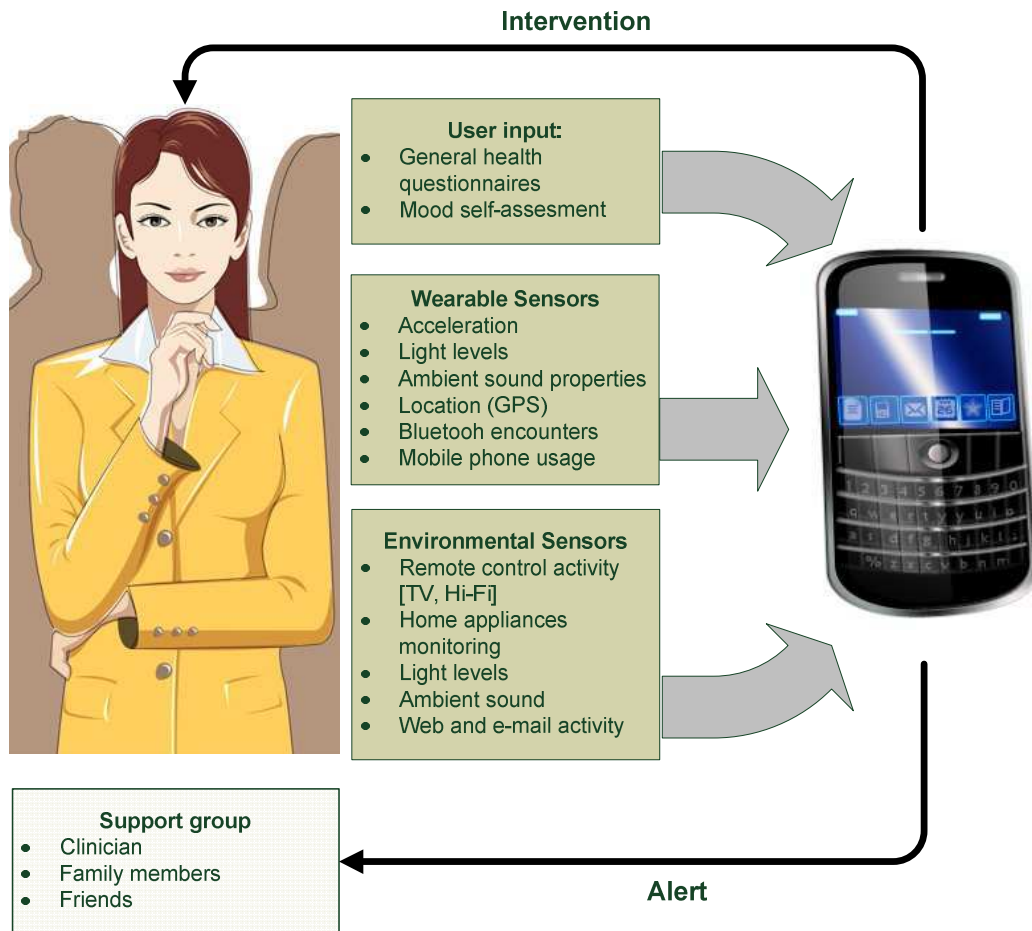

Figure 2-2 Potential PAM scheme

Other research areas of PAM are also introduced in the following sections. They include the development of processing algorithms for extracting significant information from the large amount of sensory data as well as devising a flexible architecture for the wireless network which would allow to take into account the dynamically changing conditions and factors like damaged or unavailable sensors. Another PAM-related research area is the development of a BD model. Such a model could enable the successful recognition of the early signs of an episode which would then trigger an action from the system itself, either in the form of an alert or an automated intervention, as discussed further.

All these areas were researched within the PAM project which consisted of four research teams in three institutions. Each team consisted of one research assistant and their supervisor. The division of topics covered and the overlap between the research groups is presented in Table 2-1.

Table 2-1 Research teams participating in PAM project and their areas of interest

Research team	Areas of research and development
University of Nottingham Electrical Systems and Optics Research Division	<ul style="list-style-type: none"> • Development of a PAM wearable sensor network as well as an environmental sensor suite. • Customising mobile phone to act as a sensor gateway. • Performing initial data processing. • Pattern analysis of mobile phone inputs (GPS and Bluetooth encounters)
University of Stirling School of Computing Science and Mathematics	<ul style="list-style-type: none"> • Flexible rules-based system architecture altering quantity and quality of collected data according to the current behavioural model. • Interoperability between wearable and environmental gateway. • Development of a questionnaire application for the wearable gateway. • Schemes for secure patient data retrieval and storage.
University of Southampton Institute of Sound and Vibration Research	<ul style="list-style-type: none"> • Development of processing algorithms for the researched sensory inputs • User's activity appraisal basing on acceleration data. • Customising off-the-shelf camera to detect in-home activity. • Extracting patient's daily routine from environmental data
University of Southampton School of Management	<ul style="list-style-type: none"> • Researching of a standard behavioural model for BD patients • Identifying models for particular sensor inputs.

To provide a better overview of the implemented system the data processing and architecture are briefly overviewed in this chapter. However as shown in Table 2-1 an in-depth research in these areas was performed in Universities of Southampton and Stirling.

2.2.1 Sensory inputs

The aim of a sensor network in personalised ambient monitoring is to provide empirical data to be processed in the core of the system. The sensors should be able to observe the key areas affected by the condition and its symptoms. This objective data could then be used to enhance the assessment scale input. The first step was to match expected bipolar symptoms with possible sensing techniques. Such an approach was also adopted by Wihelm and Roth in their study on panic disorder [31]. Another premise is to augment the information expected from assessment scales with an appropriate monitoring technology. Such pairings were made and are shown in Table 2-2. The pairings were created basing on current diagnostic guidelines [70] as well as consulting psychiatrists and patients from the PAM project advisory group. The patient may exhibit only a subset of the listed symptoms. However, the diagnostic criterion for BD is the occurrence of at least four of these factors [70].

The techniques proposed in Table 2-2 require the use of particular sensors. These can be arranged into two sub-groups depending on the envisioned placement: wearable and environmental. The first refers to sensors preferably attached to the patient's body or carried by them throughout the day. The latter group constitutes of stationary devices monitoring the user's home environment and their activity there. Table 2-3 presents the selected sensors in the said manner.

**Table 2-2 Bipolar syndromes matched with monitoring methods
(M – manic episode, D- depressive, M/D – applies to both)**

Type	Symptom	Possible sensing technique
M/D	Altered sleep patterns - insomnia, hypersomnia, self-deprivation of sleep	Possible to monitor with bed sensors as well as light detectors installed in the patient's home. A body worn accelerometer can be used to detect sleep patterns. As sleep deprivation is also known to trigger the episodes, effective monitoring of this area of life is of particular importance
M	Flight of ideas - increased goal oriented activity, euphoria	Monitoring number of calls and text messages and their recipients, number of physical places visited (especially in a patient's free time), unusual email (new recipients, not related to work items) and web activity. Monitoring usage of keyboards and household remote controls should also be included, as buttons are likely to be pressed harder and faster.
M/D	Psychomotor agitation (or retardation)	Body (<i>e.g.</i> wrist) worn accelerometer will detect restless behaviour and increased activity. Motion detection can also be of use.
M	Increased (excessive) social activity	Likely to manifest itself in geospatial and temporal patterns. Patients, in their free time, will visit more unusual places and meet many new people. These can be monitored via location (<i>e.g.</i> , GPS-based) tracking. Identification of crowded places (<i>e.g.</i> clubs) can be achieved through the patient's mobile device scanning for other devices [80] or quantifying the noise level of the place where the patient is
M	Talkativeness – a pressure to talk louder	Monitored by microphones designed to extract the volume of speech.
D	Concentration problems – indecisiveness	All activity is related only to work (<i>e.g.</i> when using of email and web) and becomes slow; monitoring keyboard strokes can show decreased speed of typing.
D	Lack of interest in social and other activities	Number of visited places exposed in geospatial and temporal patterns will drop as well as the number of encounters [80].
D	Diminished appetite loss of weight	Regular weight measurements can be automated as well as basic usage of kitchen appliances being monitored.

Table 2-3 Sensors proposed for PAM

Sensor	Details	Subgroup
Accelerometer	Body worn tri-axis accelerometer can facilitate monitoring physical activity, posture and (if worn during sleep) sleep patterns (see Chapter 3)	Wearable
Global Positioning System	GPS can be used to obtain precise outdoor location. The information can be used to monitor changes in activity (see Chapter 3)	Wearable
Bluetooth scanning	Monitoring Bluetooth environment can provide insight into social encounters as well as augment the localisation process (see Chapter 4)	Wearable
Mobile phone activity monitor	This could be a software suite monitoring the frequency of calls and texting sessions as well as other features (e.g. loudness of speech)	Wearable
Light detector	The detector should distinguish between natural and artificial sources of light. Turning the light on and off can be a sign of insomnia, restlessness and other behaviours related to the disorder (see Chapter 3).	Wearable/ Environmental
Microphones	The sensors should be able to pick-up the changes in volume of background noise (which might be a source of overstimulation) as well as changes to the tone and speed of speech (see Chapter 3).	Wearable/ Environmental
Remote control devices monitor	An Infra-Red detector capable of determining the speed of pressing buttons on a remote control (see Chapter 3).	Environmental
Computer software monitor	Software monitoring the speed of pressing keyboard keys as well as detecting unusual web activity.	Environmental
Weight scale	Scales capable of automated transmission of the reading to the processing device.	Environmental
Door switches	Simple on/off devices to monitor usage of household items and (if placed on cupboards in food preparation areas) to provide information regarding eating habits (see Chapter 3).	Environmental
Motion detectors	Passive Infra-Red (PIR) devices to monitor indoor mobility as well as unusual activity.	Environmental
Wide angle cameras	Further information on behaviour patterns in home environment (see Chapter 3).	Environmental
Bed sensor	This can be a pressure mat under the bed or a capacitive presence sensor embedded in quilts	Environmental

Acceptability is an important issue in choosing sensors for any implementation of a real-life system. Therefore not all the sensing techniques listed are practicable and could or should be implemented in an end PAM system. Nevertheless, the proposed network of sensors or its subset would constitute a frontend for a PAM system feeding empirical information to further layers of the system.

2.2.2 Middleware and communications link

The concept of PAM assumes the existence of a wireless sensor network (WSN) consisting of the sensors described in the previous section. WSN have been proposed for general medical care in many research projects [13]. The body-worn subset would constitute a Body Sensors Network (BSN). In the general scheme of a WSN design the sensor nodes are connected to a gateway which processes the raw sensory data and is also capable of storing and passing the information to the outside world (Figure 2-3) [81]. In case of a BSN, as considered for PAM, it is necessary for the gateway, as well as the sensors, to be portable as it needs to be carried or worn by the user along with the sensor nodes.

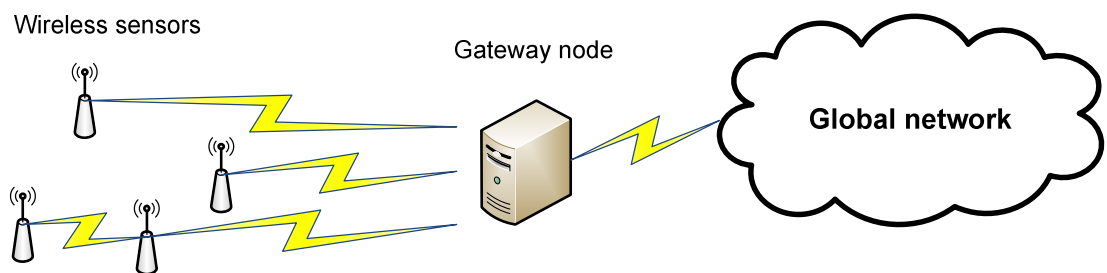

Figure 2-3 General WSN scheme [81]

There are several off-the-shelf solutions for WSN gateways and a preliminary survey was performed for possible PAM implementations. However, the specific nature of the

investigated problem is a deciding factor in the design. Any device to be carried by a patient needs to be acceptable and allow the user to adapt to it. Therefore, a mobile phone emerges as a natural candidate to fulfil the role of a gateway in the envisioned PAM BSN. The justification for such a solution is that current mobile phones have sufficient processing and storage capability, a wide range of radio connectivity (usually not limited to GSM radio bands) and provide a means of interacting with the user through a familiar interface. Moreover, the phone itself can provide a number of the discussed sensory inputs. There are, however, basic requirements for a mobile phone device to be used as a gateway in a BSN scenario:

- Programmability – possibility of equipping with custom software with sufficient access to all required hardware resources.
- Connectivity – radio stack able to communicate with the sensor nodes (e.g. Bluetooth, Wi-Fi) as well as transmitting processed data further.
- Storage – Sufficient storage space for either raw or processed sensor data (e.g. memory card interface).
- Processing power – the device should be capable of acquiring, storing and processing (to a limited extent) information fed by the sensors whilst maintaining its basic phone functionality.

The above fundamental conditions are necessary to implement a PAM gateway on any device. In practice, the majority of mid-range mobile phones (i.e. smartphones) available on the market comply with such requirements. However, utilizing mobile phones as a gateway constrains the range of possible wireless sensor interfaces to the widely implemented WLAN (IEEE 802.11) and Bluetooth connectivity.

The phone can also act as a gateway for the environmental sensors connecting to them and accessing their information whenever an environmental sensor appears in range of the wireless connection. Figure 2-4 presents the envisioned architecture of a PAM network with key elements illustrated.

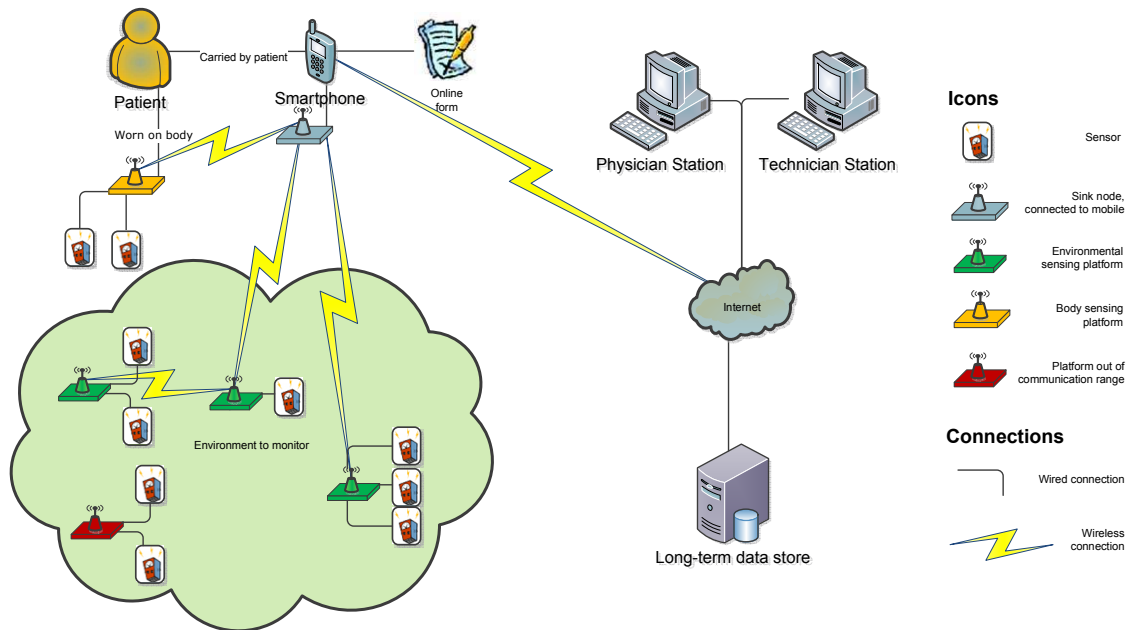

Figure 2-4 PAM architecture

2.2.3 Processing

The processing layer of the PAM constitutes of a set of processing techniques extracting meaningful information from the data providing real-time embedded processing capabilities. Algorithms that learn from normative data and that can deal with missing data-points are a necessity. Furthermore there is a need for researching models of normal activity signatures and techniques for their derivation. As a generative model of normality could be devised using multi-dimensional inputs, robustness to missing data points can be built into the system. The advantage of computational intelligence based methods (such as artificial neural

networks) is that once trained they provide a single layer model which can be readily and speedily embedded into such a distributed network. Appropriate algorithms can then be used to downsize the data transmitted further so that details sent are directly relevant to the patient's mental health state. These investigations lied in the core of the work performed by the University of Southampton research team as part of the PAM project [66].

Processing is also relevant from the ethical perspective. Data collected by the sensor network is likely to carry sensitive information regarding the patient and should be protected. Processing is applied in the early stages of data flow with only key (clinically significant) data features extracted. This reduces the risk of sensitive data becoming vulnerable to malicious use.

2.2.4 Personalised feedback

As stated in previous sections – the aim of a PAM system is to detect early signs of an imminent BD episode and utilize the information to trigger actions that could help the patient take control before serious behavioural changes occur. In order to do so, the system should incorporate a personalized feedback mechanism that would enable it to suggest simple non-clinical interventions as well as generate alerts for the patient's support group which includes a clinician who then can advise on an appropriate course of action based on the detected activity signatures and their clinical judgment. The concepts outlined in this paragraph are not addressed within this study but constitute a basis for future work that could follow the investigations presented within this thesis.

Such PAM interventions could include contacting the practitioner or support group member (e.g. family member) in the case of a serious change in the patient's state requiring immediate attention via automated alerts using established channels such as text messaging.

Moreover, the system can prompt the user to take prescribed medication according to clinical advice helping to ensure the patient's concordance with the agreed management regime.

Some interventions would occur only in the event of detecting a high probability of a manic episode. Those could consist of prompting the patient to adhere to sensible sleep patterns, alerting when skipping rest as well as helping to avoid overstimulation when too much noise and/or light is detected. What is more, preventive measures against unwanted consequences could be taken, such as blocking web content known to cause the patient to engage in risky activities. Similarly, in the case of depression prompts could encourage the user to go out when a lack of mobility is detected and interact with the outside world or to call a member of their support group such as a family member or friend. The system could also suggest performing physical activities and exercises (thus avoiding physical inactivity and stagnation).

In order to avoid disruptions to daily rhythms triggering an episode, a PAM system could also provide time management tools for daily (and also work-related) tasks to avoid them influencing daily patterns. The system would also facilitate healthy lifestyle including advice on diet and activities and encourage to keeping a regular healthy lifestyle routine.

The intervention spectrum would also be highly personalised depending on a patient's particular needs. The patient would be able to configure appropriate intervention courses from a given set which they could modify or amend according to their judgment (in consultation with their clinician).

2.3 Summary

Background analysis presented in the previous chapter suggested that the management regime of bipolar disorder could benefit from the use of pervasive technology. This chapter

has presented an overview of the condition with its main symptoms and usual course. Areas of life likely to be affected by the disorder were identified and matched with a potential sensing technique. The concept of PAM as a support platform for bipolar patients was introduced.

The basis of PAM is a network of ambient sensors scattered within the patient's environment, which is the focus of this work. The remaining research fields of PAM are processing, modelling and system architecture which were also introduced in this chapter. The sensors and methodology outlined above were then implemented as the PAM system prototype which was the first step to validate the concept of PAM. The description of the design and development process of the prototype is discussed in the following chapter.

3 Implementation of PAM

This chapter covers the implementation of a PAM system according to the specification established in Chapter 2. The work included researching and configuring off-the-shelf solutions, hardware design and the development of custom sensor sets to work as wearable and environmental parts in the described scenarios. Moreover, software suites for mobile devices and stationary computers were developed enabling those platforms to act as sensor network nodes.

The main purpose of devising and testing a working PAM prototype was to move forward the feasibility study aiming to:

- Identify and address specific design requirements of a PAM system
- Evaluate the proposed methodology of monitoring changing behavioural patterns
- Infer the value or redundancy of information provided by the sensors
- Use the data from initial experimentation as a basis for a behavioural model

Figure 3-1 shows the overview of the realised prototype system, whereas the following sections explain the premise and implementation of its separate elements.

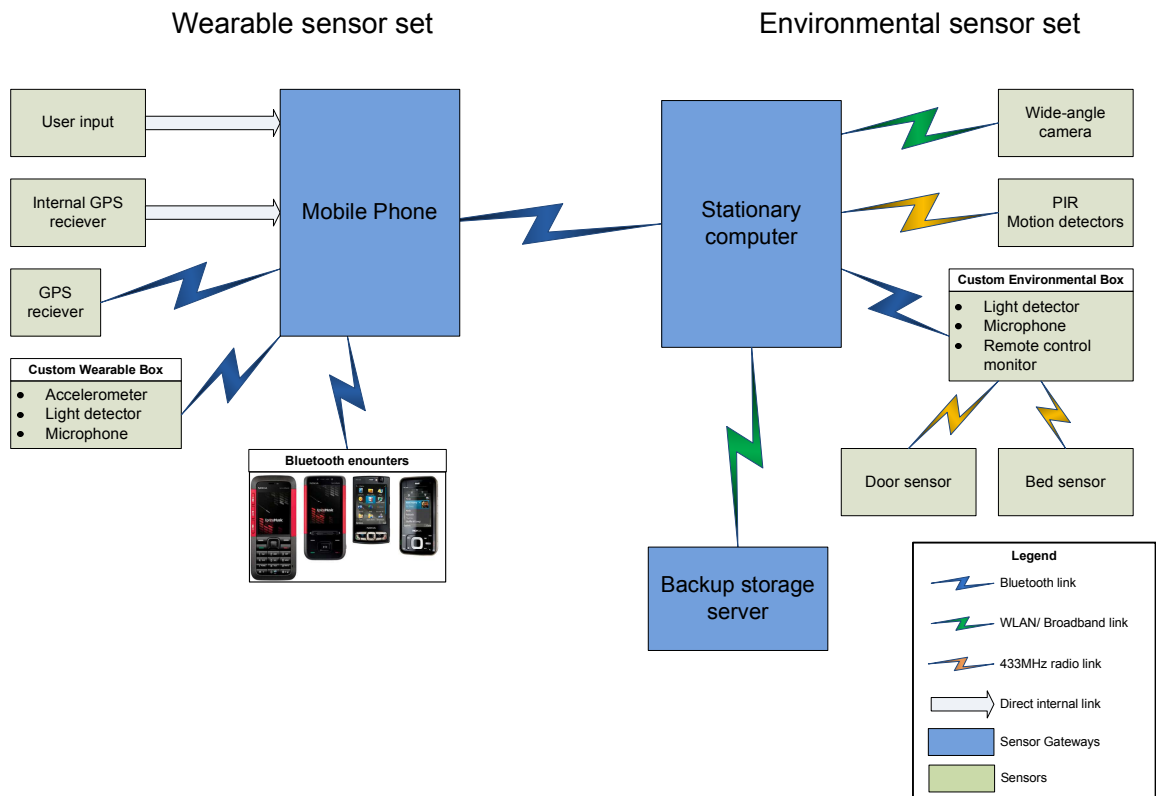

Figure 3-1 An overview of the PAM prototype

The implementation was then evaluated during a technical trial involving users with no history of BD as well as patients (at a later stage). Results of these can be found in the following chapters.

3.1 Wearable sensors

The wearable set is a collection of sensors to be worn (carried) by the patients during their day routine designed to observe key behavioural patterns. Because of the fact that these sensors, ideally, should accompany the user at most times they must be implemented so as to minimise their obtrusiveness. The potential sensing techniques, to be used in a PAM system, are outlined in the previous chapter. This section discusses in detail the implementation of a prototype set of devices constituting the wearable part of the system.

The wearable sensors selected for the PAM prototype justified in Tables 2-2 and 2-3 were as follows:

- Positioning sensor
- Accelerometer
- Light detector
- Microphone
- Bluetooth scans
- Mobile phone call monitor

The implementation of a call monitor discussed in Chapter 2 was abandoned due to privacy concerns over such monitoring, as well as technical obstructions discussed in the software section of this chapter (which also covers the functional description of the phone software elements). Realisation and evaluation of Bluetooth encounter monitoring is covered in-depth in Chapter 5.

There were several design requirements to be considered whilst assembling the sensor set. Firstly, using the mobile phone as the hub for the wearable part of the system imposed a constraint on connectivity. Most modern phones are equipped with Bluetooth connectivity, whereas a number of higher-end devices additionally have WLAN capability. Therefore any sensor considered for the implementation should have at least one of the two. Secondly, the wearability of the set requires all sensors to be capable of standalone operation without being connected to a mains power source. Thirdly, the sensors need to be small and unobtrusive in order to be usable. These three conditions should be fulfilled by all of the considered sensing micro-devices.

3.1.1 Position sensor

There are several methods of obtaining the position of a device. The Global Positioning System (GPS) is currently the most convenient method of obtaining geospatial data. Accuracy available for non-military users is limited but sufficient for most uses. Cheap commercial receivers able to provide position data with an accuracy of around 3m are widely available [82]. There are also alternative systems similar to GPS being implemented or developed, although they either lack coverage and accuracy (Russian GLONASS) or are at an early stage of development (European Galileo and Chinese Compass).

The growing availability of GPS positioning has fuelled the emergence of Location Based Services (LBS) which means the provision of information and functionality in relation to the user's geographical position [83]. This has inspired the integration of GPS receivers into everyday devices such as digital cameras, personal computers, and, most significantly, mobile phones.

The main disadvantage of satellite-based positioning is obstruction of the signal occurring in places hidden from a clear view of the sky. Therefore positioning using GPS is impracticable inside large structures (e.g. buildings) or underground. Tackling the problem of indoor localisation is a growing research field of its own. Methods being explored include using Wireless network structures (Wi-Fi) [84], RFID tags, accelerometers, and GSM cell information[85].

Integrating GPS positioning into the mobile phone based PAM architecture was achieved in two ways. Firstly, widely available Bluetooth-enabled GPS receivers could be paired with the mobile phone. Secondly the phone used as the hub could itself have a GPS receiver integrated. Table 3-1 shows the advantages and disadvantages of both solutions related

mostly to high power consumption of a standard GPS receiver. Both solutions were implemented and tested.

Table 3-1 Comparison of GPS position providers

	GPS built in the mobile phone	External Bluetooth GPS
Advantages	Device directly connected to the hub (phone). Internal software control over the functionality	Can be paired with most phones As an autonomous device does not influence the functionality of the system if it fails
Disadvantages	Common power source with the main hub causing the entire system to drop down after exhausting the battery Currently available in a limited number of phones	Adds to the number of separate devices to be carried by the user and so decreases usability

3.1.2 Custom Wearable Box (CWB)

Aside from the GPS positioning described above, there were three further sensory inputs to be implemented within the system: accelerometer, light sensor and a microphone. Since having three separate would be impracticable from a usability point of view, an integrated solution was sought. Unlike GPS positioning units, there are few widely available integrated solutions implementing these sensors which would fulfil the design requirements. Although several mobile phones available on the market integrated these sensors, their utilisation in the prototype was not considered, at the time, due to the following factors:

- Very few available devices with a software-accessible light sensor
- Mid-range mobile phones record highly compressed sound which obstructs processing for desired audio features

- The accelerometer data processing methods devised by University of Southampton research team required the sensor to be fixed in relation to the user's body, which couldn't be achieved assuming normal usage of the phone

Taking the above considerations into account, a custom wearable unit consisting of the three specified sensors was designed and developed. The aim was to create a robust, wearable and simple device providing microphone, light and acceleration data streams via Bluetooth radio making it easy to interface to a mobile phone or any other Bluetooth enabled device. Moreover, the device should have some processing capability for basic operations on analogue input signals coming from sensory data. Figure 3-2 presents the functional block schematic of the device with the details explained in the following subsections.

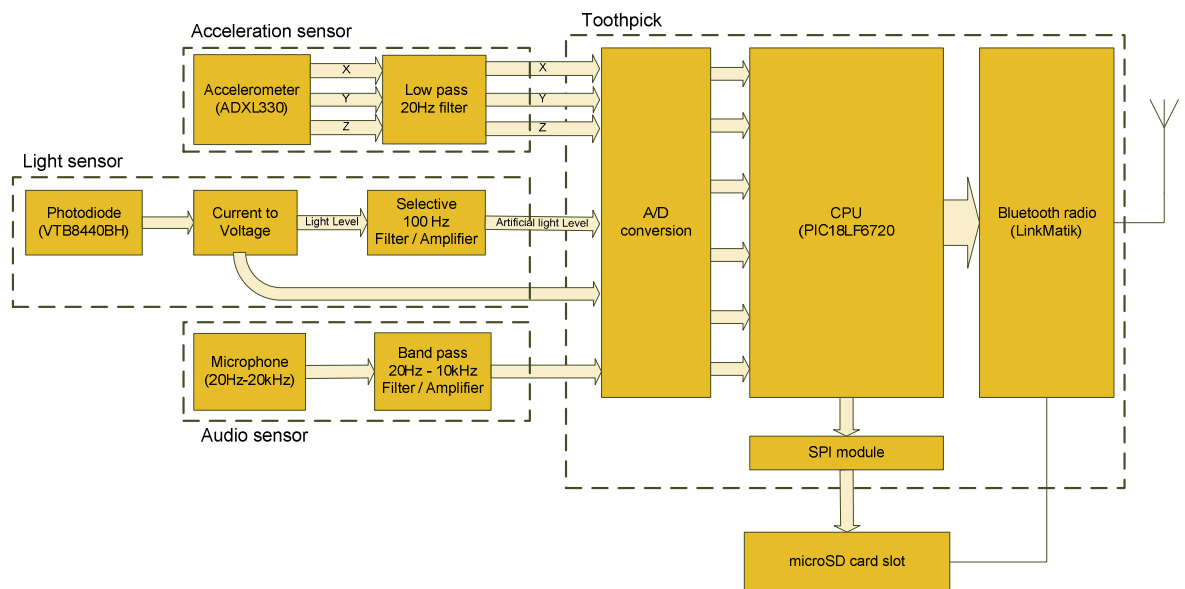

Figure 3-2 The custom wearable box schema

3.1.2.1 Accelerometer

Monitoring activity using accelerometers requires the device's sampling frequency and the amplitude range to correspond to the observed motion in a human body. In terms of

frequency range it is known that while walking at normal speeds the bulk of acceleration power in the upper body ranges from 0.8–5 Hz, whereas the most abrupt accelerations occur at the foot in the vertical direction during heel strike with values up to 60 Hz [24]. However, studies with the accelerometer attached on the ankle have shown that more than 90% of acceleration power concentrates below 15Hz in the frequency spectrum [24]. For the low back or the head the value was significantly smaller, ranging from 0.5 Hz to 4 Hz [24]. In terms of amplitudes of accelerations involved in locomotion, these are usually higher in the vertical direction than in both horizontal directions [86]. During walking the accelerations range from a maximum of 0.4 g at the lower back to 3g at lower limbs [86]. The maximum acceleration during running ranges from 4g at the head and lower back to 12g when measured at the ankle [86].

Taking the above considerations into account, it was established that the Analog Devices ADXL330 accelerometer with three analogue outputs would suffice to monitor a person's activity provided that the target location of the sensor is close to the body's centre of gravity (e.g. at the lower back). Alternatively, the sensor could be located on the upper parts of upper limbs although here the acceleration might go out of the range during more vigorous activities from the user. The main parameters of the sensor relevant for the application are presented in Table 3-2. In the electronic design the analogue output of the three axes of the accelerometer were fed into the ADC of the main CPU. However, it is possible to pre-filter the output using a built in 32 k Ω resistor and an appropriately chosen external capacitor according to the equation: $f=1/(2\pi(32\text{ k}\Omega) \times C)$. The value for the capacitors is 0.47 μ F which sets the low-pass bandwidth at 20Hz so reducing the noise whilst still recording relevant body movements information. The schematic is presented in the Figure 3-3.

Table 3-2 Selected parameters of the ADXL330 accelerometer [87]

Parameter	Value
Measurement range	± 3.6 g
Sensitivity at X, Y, Z axis	300 mV/g
Bandwidth X, Y axis (No external filter)	1600 Hz
Bandwidth Z axis (No external filter)	550 Hz
Operating Temperature Range	-25 to +70 °C

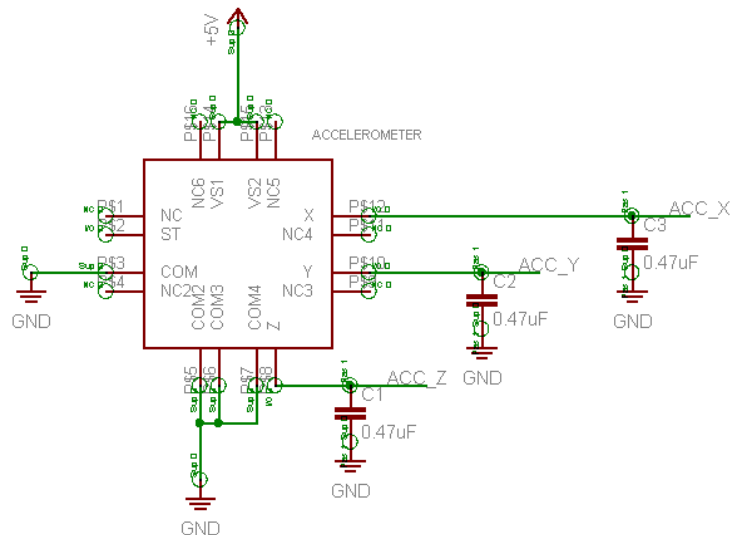

Figure 3-3 The accelerometer module schematic

3.1.2.2 Light Sensor

There are two main reasons for employing light sensing into a PAM system. Firstly, there are indications that there is a correlation between reduced hours of sunlight and the current mood of some BD patients [88], although the connection is not that apparent as in people suffering from Seasonal Affective Disorder (SAD) [89]. Secondly, disturbances in sleep patterns as well as shifts between day and night activities are among the most common

effects of a BD episode and these are very likely to become apparent in light level patterns. For example a BD patient experiencing a manic episode will tend to visit stimulating places filled with lights (e.g. a night club) whereas during depression if suffering from insomnia such a person would turn on lighting during their usual resting time.

The above considerations led to a conclusion that monitoring the light level in the user's immediate surrounding alone might not be informative enough and an improvement could be achieved by discriminating whether the source of the light detected is natural or artificial so giving a better understanding of the observed environment. Therefore the final circuit was designed to provide two output analogue channels.

The first output is directly related to the current generated by a photodiode which is proportional to the amount of visible light shining on the surface of the component. The conversion to a voltage output signal was achieved using an amplifier configured as the current to voltage converter (transimpedance amplifier) with a high gain ratio (Figure 3-4).

The second output is generated by processing the latter signal to extract the AC component. The premise is that light coming from an artificial source carries such a component due to its mains power source. Mains power alternating with a 50Hz frequency will rapidly switch the light on and off whether it is an incandescent light bulb or a fluorescent lamp. It is worth noting that the alternating light component arising from the 50Hz power source will have a 100 Hz frequency as the polarity of the supply is irrelevant to the light generated by an artificial source. The above does not apply to any battery operated light or modern LED lighting systems, however, such lighting is still marginal in exploitation, and so it is a valid assumption that most current artificial sources will be distinguished by the proposed solution.

In the final design, the general light signal is fed to an active selective filter with parameters chosen to filter and amplify the 100 Hz component. The output of such a filter is

a sine wave whose amplitude is proportional to the artificial light component. It was decided to perform the process of integration and rectification of this signal digitally in the main processing unit of the wearable box. The schematic of the light sensor can be found in Figure 3-4.

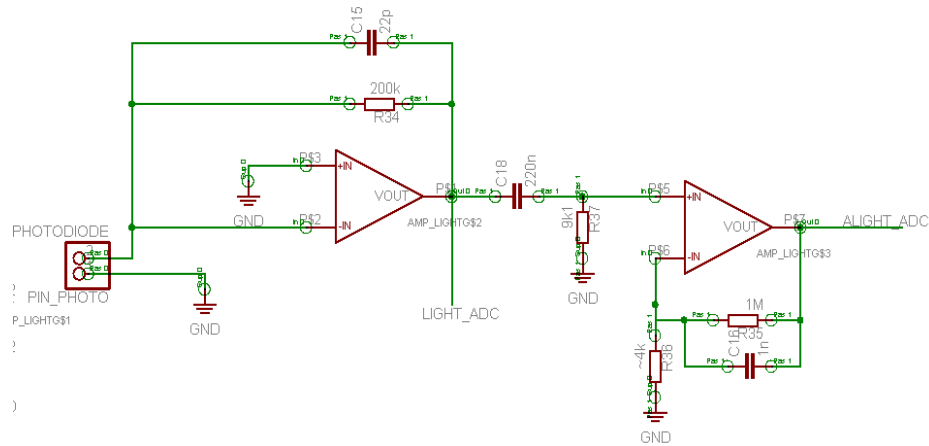

Figure 3-4 The light detector schematic

The microcurrent originating from the photodiode is transformed into a voltage signal using the operation amplifier in a transimpedance setup with a high gain. The output is fed to the analogue to digital converter of the CPU as a general light level. The second stage uses an active selective filter to extract the artificial light component (as described above) and amplify this signal. The selective band of 100Hz is set using a low pass input filter at the input and a high-pass feedback loop. The values of resistors and capacitors are selected to achieve a gain of approximately 250 according to the formula:

$$A_G \cong 1 + \frac{R35}{R36} = 1 + \frac{1M\Omega}{4k\Omega} = 251$$

3.1.2.3 Sensing of auditory environment

The analysis of ambient sound can carry numerous types of information relevant to monitoring the current state of a bipolar patient. Firstly, louder and faster speech is one of

the main syndromes of a manic episode whereas quiet and slowed pronunciation may be indicative of depression [70]. Secondly, it is known that loud noises can cause overstimulation and trigger a bipolar episode and finally during an ongoing manic episode some patients prefer being in noisy lively environments. Recording microphone data, more directly than the sensors discussed above, poses a serious privacy problem. Therefore it was decided that the functionality of the microphone used in the implementation of the wearable box would be constrained by the design itself thus reducing to a minimum of any threat of malicious use against prospective users. An added advantage of such an approach was that the design could be simplified and development time reduced as features likely to be rejected for privacy reasons (e.g. recording and storing high quality audio signal) were omitted.

The electronic circuit used consists of an active band pass filter set to filter the signal emerging from a miniature microphone (Projects Unlimited - POM-1644P-NF-R). The cut-off frequencies were set between 20Hz and 10 kHz matching most man-made audible sounds (e.g. speech or music) whilst filtering out irrelevant noise. The full schematic is presented in the Figure 3-5.

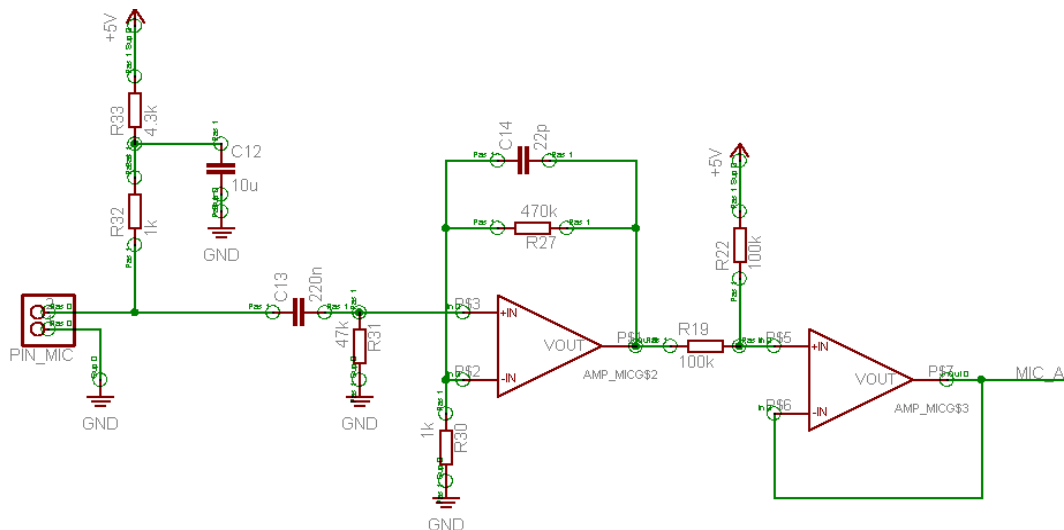

Figure 3-5 Microphone module schematic

As the recording and storage of actual audio is problematic due to privacy issues and technical limitations, the sound has to be processed within the wearable unit to extract the audio features that may be useful for deriving information about the ambient environment. This problem has already been tackled by various fields of research including intelligent hearing aids where the device is able to select an appropriate software-profile based on the type of the auditory environment. Features used in these algorithms include temporal measurements such as Zero Crossing Rate (ZCR) or Short-Time Energy (STE) as well as frequency domain features such as spectral flux, spectral centroid or voice to white ratio (v2w) [90,91]. Extracting frequency domain features poses a higher demand on processing powers which in practice would mean incorporating a separate Digital Signal Processor (DSP) solely for the microphone. Therefore it was decided that the main CPU of the wearable box would handle only basic sound processing by extracting temporal features of the auditory surroundings (i.e. STE and ZCR).

3.1.2.4 CPU and firmware

All of the described sub-modules of the Custom Wearable Box (CWB) output an analogue signal. Digitisation requires an analogue-to-digital (A/D) converter as well as a processing unit which can then feed the collected and processed data through a Bluetooth radio module. In order to minimize development time of the CWB, a solution integrating all those components was found. The module (RF Solutions Toothpick v. 2.0) integrates a PIC microcontroller serving as a A/D converter as well as a processing unit. The module also includes a serial Bluetooth module (Linkmatik LMT) capable of transmitting serial data over this radio interface. The unit also provides other interfaces like simple digital inputs, UART and I²C communication protocols not utilised in this implementation. The main parameters

relevant to the implementation of the CWB are presented in the Table 3-3 and are sufficient to perform key required operations.

Table 3-3 Selected parameters of the CPU [92]

Parameter	Value
Flash memory	128Kbyte
RAM memory	3.5Kbyte
Clock frequency	24MHz
A/D channels	12
A/D resolution	10 bit

Custom firmware was developed for the CWB which maintains two-way communication with the target host device (e.g. mobile phone), monitors battery voltage and continuously acquires data in one of the following three modes:

Mode 0 – default mode where the device does not acquire nor output any sensor data but the connection between the CWB and the host is kept alive and maintained to receive commands from the host (e.g. the mobile phone).

Mode 1 – activated by a host command. The device acquires acceleration data with a frequency of 20Hz and feeds it directly through the serial link. Natural and artificial light levels are acquired with the latter being rectified and integrated. A reading of both levels is acquired and fed every second.

Mode 2 – activated by a host command. The device acquires microphone data with the highest available frequency (i.e. 16 kHz) and creates temporary sound frames containing 1024 samples. Temporal features of Mean Energy and Zero Crossing Rate within such

frames are then calculated and sent through the radio link. This mode needs to be separate from the acceleration and light level acquisition due to high demand on processing power.

The data is sent in binary format according to a framing protocol. The decoding of frames needs to be implemented on the receiving device in order to extract the sensor readings. The status of the device is communicated to the user via two LED's connected to digital outputs. Although the hardware links to interface a memory card were included into the design, the final firmware did not implement this functionality due to high memory demand of buffers necessary to operate with a memory card.

3.1.2.5 Battery and packaging

The CWB is powered through a high-performance lithium-ion battery with a nominal capacity of 1080mAh ensuring up to 7 days of charge free usage period. The charging circuit for the device is contained in a designated charger thus saving space inside the box.

The circuit board was designed to fit two types of wearable casings: OKW Ergo S and OKW Soft-case S. The smaller of the two (54mm width, 83mm length, 14mm depth) is the Soft-case S. This rounded rectangular-shaped box is equipped with a belt clip for wearing close to the body's centre of gravity (Figure 3-6 left). The second box (Ergo S) is profiled and fitted with a special strap to be worn on a limb (Figure 3-6 right). Figure 3-7 illustrates the placement of elements inside the belt-worn box.



Figure 3-6 The two options of CWB belt-worn (left) and on the arm (right)

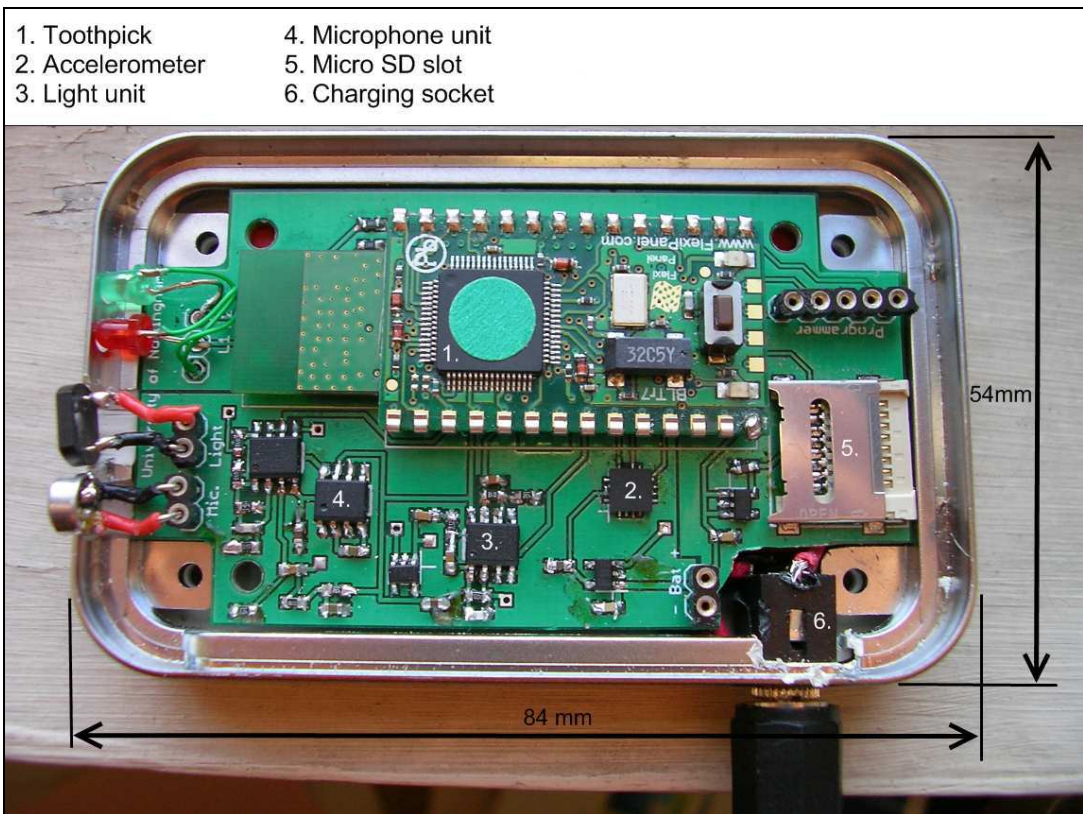

Figure 3-7 The inside of a CWB

3.1.3 Mobile phone

Mobile phones have evolved to offer capabilities exceeding well beyond the provision of voice communication and text messaging. The emergence of high speed packet transmission technology (i.e. 3rd generation or 3G telephony) accelerated the growth of the functionalities available. For many users the phone has become a personal hub providing web browsing, scheduling, e-mail communication, music and video entertainment and more. Recent years have seen the emergence of mobile operating systems (e.g. Android), making it possible for developers to create universal (to some extent) software, independent of the hardware implementation or phone make. The specifics of programming for particular operating systems are described in the software section of this chapter.

The phone is the most crucial element of the wearable part of the PAM. Not only does it serve as a hub and storage facility for other sensors but it provides a link between the system and the outside world through the use of mobile packet transmission protocols such as GPRS or HSDPA. More significantly as a device that is widely available and utilised, it provides a means of interacting with the prospective user through a well accustomed interface. It is proposed that such familiarity will also work in favour of the acceptability of the system as a whole. Moreover some phones have sensors relevant to the PAM integrated in their circuitry.

The base requirements for a particular mobile phone capable of serving as a gateway for the sensor were itemised in Chapter 2. Those are programmability, connectivity, sufficient storage and adequate processing power. The market offers a wide range of such devices. Table 3-4 presents the devices selected for initial experimentation provided by two leading manufacturers (Nokia and Sony Ericsson). The main reasons behind such selection were: similarity of platforms allowing the development applications that would be interoperable

between all the devices, good developer support from the manufacturers and their relatively low cost.

Table 3-4 Phones selected for PAM

Device	Software platform	Programming languages	Connectivity	Integrated GPS	Integrated Accelerometer
Nokia 6120 Navigator	Symbian OS	Java, C++	Bluetooth, 3G	Yes	Yes
Sony Ericsson K550	Java Platform 7	Java	Bluetooth, 3G	No	No
Sony Ericsson C510	Java Platform 8	Java	Bluetooth, 3G	No	Yes
Sony Ericsson W715	Java Platform 8	Java	Bluetooth, WLAN, 3G	Yes	Yes

The process of customizing the phone’s software to suit the PAM system is described in the software section of this chapter.

3.2 Environmental sensors

The environmental sensors are designed to sense the ambience of the user’s home setting. The premise is that the properties of the patients’ surroundings can influence their behaviour and vice versa; a change in behaviour could become apparent in environmental monitoring data. The group includes a range of stationary devices set in the patient’s home. The sensors scattered in key areas related with behaviour patterns (as outlined in Chapter 2) include: light detector, microphone, a remote control monitor, door and appliance monitoring, motion detectors, wide angle cameras and bed sensors.

Although there is a potential gain in collecting environmental in-home data, implementation of such sensors in a multi-person home is likely to obtain ambiguous information. The problem of pervasive monitoring with multiple inhabitants is a complex

research issue of its own with many factors to be considered [93]. Attempts to tackle the problem include probabilistic modelling [94] to hardware solutions [95]. However, most currently researched pervasive implementations assume a single-user occupancy [94]. Such an approach was taken in the design process of the PAM prototype. Therefore the trials described in further chapters were conducted, where possible, in such conditions.

3.2.1 PC computer and its role

The implementation of a computer software monitor was abandoned due to privacy concerns and a high likelihood of unacceptability. In the PAM prototype, however, a stationary PC is present to act as a sensor gateway for the environmental part of the setup, separating it from the wearable part. Moreover, the computer also operates as an end storage and transfer facility for the data gathered by the wearable kit and temporarily stored on the mobile phone serving as a wearable sensor gateway. This solution was chosen due to the fact that a PC poses a lesser risk exceeding storage, processing power and other resources that are limited on a mobile phone. The computer can also be connected to the global network via a reliable broadband link providing a means of backing up the prototype trial data to a secure off-site server.

Furthermore, the PC ensured synchronisation between data inputs as environmental information was collected and stored real-time whereas the wearable sensor data was time-stamped by the mobile phone according to the clock synchronised with the PC.

3.2.2 Camera

The main advantage of utilising a camera for monitoring behavioural patterns is the fact that a single device can observe simultaneously a number of areas of interest (AOI) that fall within its field of view. An example is a camera observing the kitchen area considering the

refrigerator, stove, oven etc. as separate AOIs [96]. The main disadvantage, however, is that a camera-based monitoring carries significant negative connotations for any prospective user. The notion of being observed in a direct way might cause compliance issues as well as make it less likely for the system to be accepted as a whole.

Considering those factors, a processing scheme for detecting activity in predefined AOIs based on a wireless WLAN-enabled camera compatible with the system described in this thesis, was developed in the University of Southampton as part of the PAM project. The hardware consists of a wireless camera (Edimax IC-1520DPg) with a 179° horizontal and 129° vertical field of view. The camera is to be mounted as high in the room as possible to get a bird's-eye view as this minimises the problems of objects passing too close in front of the camera, which could result in obstruction of all AOIs.

The processing algorithm used to detect activity aims to subtract movement from the background of the scene by differentiating consecutive frames resulting (ideally) in black images with white blobs where movement was detected. Such an image is then correlated with pre-marked areas of interest. If enough movement is detected (i.e. if a sufficient number of pixels in an AOI are white) then it is assumed that activity was performed in this area.

Figure 3-8 left presents an example of a camera image before processing with AOIs marked and Figure 3-8 right shows blobs of activity detected in consecutive frames over the time of 5 minutes [96]. In this example activity was detected only in one of the three selected AOIs. At this stage, any movement (i.e. white blob), within the AOI was considered to be an activity event. However, further studies on the topic of processing blobs was conducted in the University of Southampton.

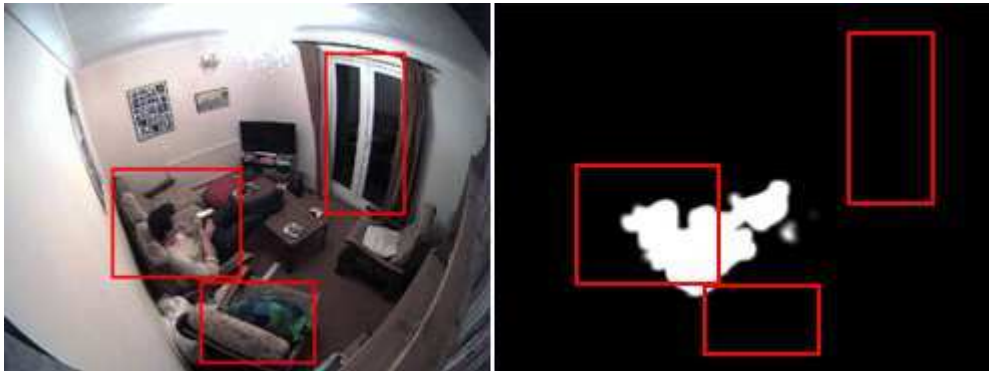

Figure 3-8 An unprocessed camera image with AOI marked (left) and processed blobs (right)

The camera interface consists of two major elements. The first is a standard File Transfer Protocol (FTP) server set to receive raw images from the wireless camera with the desired frequency. The other is a custom written script created in the MATLAB programming environment designed in the University of Southampton to mark the AOIs within the view of the camera and then process the subsequent frames received from the sensor to detect changes according to the algorithm described. The system stores a simplified set of records consisting of a timestamp and AOI identifier where activity was detected rather than raw images that might pose privacy concerns for any future user [96].

3.2.3 Motion detectors

Motion detectors are a simple and widely practiced way of detecting a user's presence in a particular area inside the house. Depending on their location, logging such events can be indicative of many behavioural patterns such as the time spent at home or eating habits in case of a detector placed in the food preparation area. As stated in chapter 2 all those patterns are likely to be affected by the course of BD.

There are many off-the-shelf systems incorporating passive infra-red (PIR) motion detectors, as such sensors are widely used in burglar alarms and intelligent home systems. The latter group includes systems based on a wireless X10 radio protocol using 433 MHz

(310MHz in the United States) radio frequency as a communication channel between sensors and a central station which can be interfaced with a computer. Such a solution was adapted to the PAM system by the researchers in the University of Southampton. The implementation consisted of a set Marmitek MS13E2 indoor wireless PIR sensors paired with a base station CM15Pro X10. The station was connected to the computer station, equipped with Active Home software, via the universal serial bus (USB).

The Active Home is a commercial suite designed to maintain and control devices compatible with the X10 protocol as the motion detectors (PIR sensors) used in this prototype of PAM. Among its features, the software allows the creation of scripts that execute when the events originating from X10 devices occur. Such functionality was used to customize this suite to process PIR events. This customisation was also performed by the researchers in the University of Southampton.

When a sensor detects motion in its range, it sends an event signal to the X10 interface linked to the stationary computer equipped with the software. The Active Home then triggers a custom script designed to log the event in the same manner and in conjunction with other sensor data.

3.2.4 Custom environmental box (CEB) and system

Similarly to some wearable sensors some of the desired sensory inputs are impracticable in implementation using market solutions. Therefore custom devices realising those inputs were designed and developed. The main aim was to create a unit able to collect data from sensors such as: light detector, microphone, a remote control monitor, door switches and bed presence. Since those devices are likely to be scattered within the user's home it was impossible to design a single device providing all the inputs. Instead, a system was devised which consisted of a set of nodes communicating with the Custom Environmental Box

(CEB) using a 433MHz radio link and a simplified protocol. The CEB is then able to connect (wirelessly) to the base computer serving as the main environmental gateway and storage facility. The scheme for the system is shown in Figure 3-9.

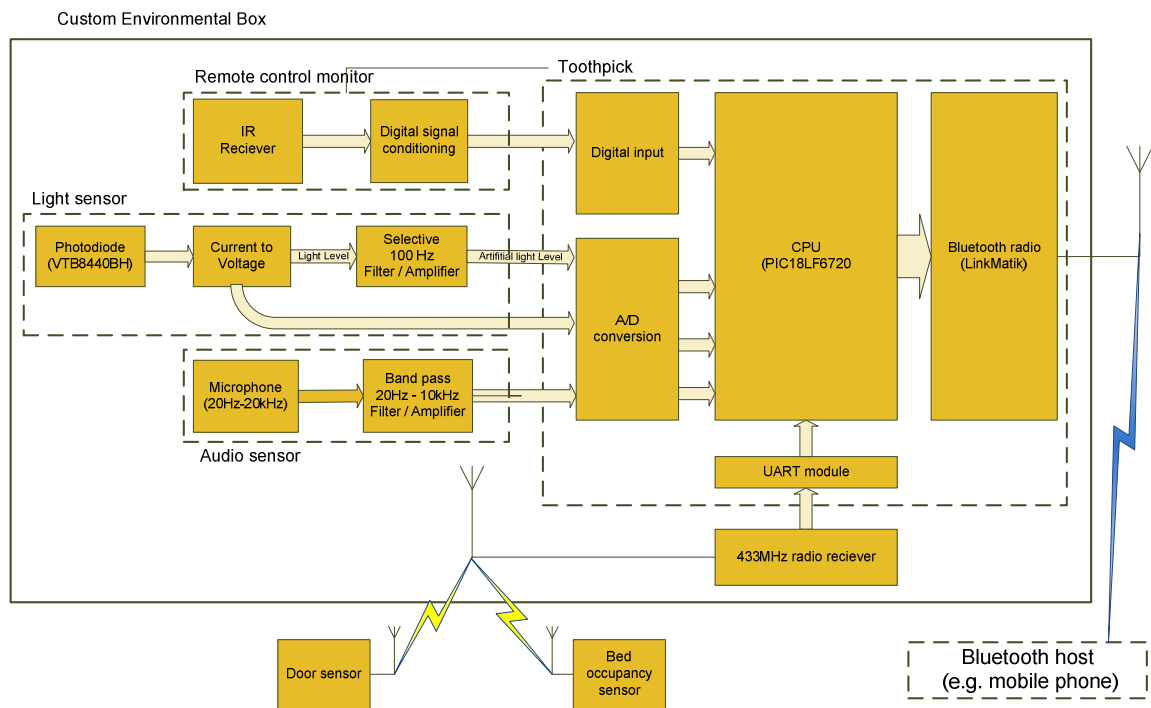

Figure 3-9 Environmental system schema

At the core of the design lies the architecture used in the wearable box. It was decided to use Bluetooth as the main connection link to the base PC. Such a solution made it possible to pair the CEB with a mobile phone thus providing more flexibility for future PAM configurations (i.e. possible to set up without the use of a stationary PC).

3.2.4.1 Door switches

Monitoring door opening times within a household can be indicative of personal behavioural patterns and activities. For this purpose a set of simple battery-operated door switches was devised. The design consists of a magnetic reed switch, a small microcontroller

(PIC10F) and a 433MHz transmitter (MK Consultants MKT1). When a door opens, the static magnet located on it, parts with the main casing of the sensor causing the reed switch to short the digital input of the microcontroller to ground. The microcontroller is then woken up to transmit a set of characters to the CEB indicating the current state of the door. In order to simplify the design, the radio link is solely one-way with no acknowledgements of reception nor the option to send commands to the sensor.

3.2.4.2 Bed usage sensor

Monitoring sleep patterns is of particular importance in managing the course of BD. Firstly, disturbed sleep can trigger an onset of an episode [75,97]. Secondly it is an important diagnostic indicator that an episode of either kind is occurring [53]. However, inserting sensing technology into such a setting may pose acceptability issues as prospective users are likely to be uncomfortable with direct sensing of presence in their own bed.

The solution utilised in this study incorporated a single pressure mat. Applying pressure causes the two conductive foil membranes to meet and cause a short-circuit. The two membranes are connected to a similar microcontroller/transmitter device as used in the case of door switches. Therefore, any pressure event is transmitted to the CEB. If the mat can be placed under the top mattress – the pressing event will directly relate to the user’s presence in the bed. Alternatively the mat can be placed next to the bed where there is a high possibility of the user stepping onto it when both, going to and leaving their bed. Although such a solution is not ideal for the purpose, it was considered to be a more acceptable placement for the experimental subjects.

3.2.4.3 Remote control monitor

Leisure time is a significant part of peoples' everyday schedule. The vast majority of households are equipped with entertainment technology. This includes television sets, DVD players, high fidelity audio sets etc. Most of those can be controlled via the use of infra red remote control devices. As indecisiveness, flight of ideas and problems with concentration are among the main indicators of a BD episode, patterns of using entertainment devices can change significantly [70]. What is more, prolonged periods of inactivity in front of the TV are common during major depression [55]. Monitoring the use of remote control devices can give an insight into patterns of using entertainment equipment as well as the way it is being used. For example the indecisiveness of the user will manifest itself by changing the channels in a more chaotic and faster manner than usual. Such premises led to the inclusion of a means of monitoring remote controls in the environmental sensor set.

Remote controls typically use modulated infra-red (IR) light to transmit a set of binary encoded commands to the host equipment which is equipped with a receiver and a decoding circuit. The transmission is one-way and no feedback is sent back to the control device. The command code depends on the manufacturer and there are several proprietary protocols used (e.g. RC-5 or SIRCS) with no common industrial standard. Therefore, it is impracticable to decode particular commands and a more universal solution of logging general remote control activity was utilised (see Firmware section below).

The remote control IR light signal is detectable by any other receiver in the view range of the remote control as long as it is sensitive to the appropriate wavelength (typically 940 nm). Such a detector is capable of capturing the binary sequence with the encoded command.

The hardware used in the experiment consists of an IR receiver coupled with a microcontroller (PC12F) which demodulates the signal and outputs the binary signal to the

digital input port of the main CEB processing unit (i.e. Toothpick). The signal can be then interpreted within. The schema is presented in Figure 3-10.

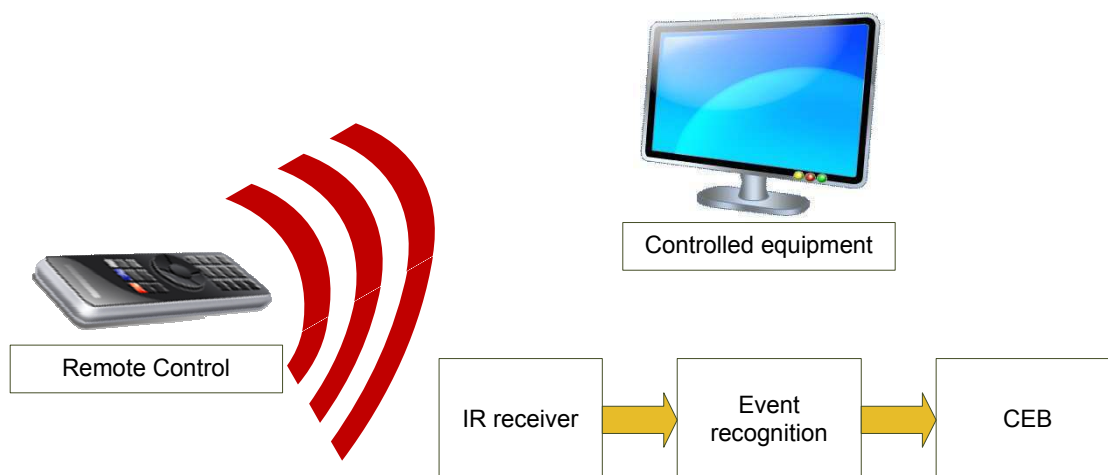

Figure 3-10 The remote control monitoring scheme. The signal from the remote control is received by both: the equipment and an IR receiver connected to the CEB. Each signal recognised as a remote control command is then stored as a binary event.

3.2.4.4 Light detector and microphone

The CEB incorporated a light sensor as well as a microphone to fulfil the same purposes as in the wearable device. This will create an alternative dataset for the user's home where the wearable device is unlikely to be carried. In particular a stationary light detector is more likely to detect the user turning on the light during usual rest time.

The hardware implementation is identical to the wearable one with the sensors placed in the main housing of the CEB and interfaced to the A/D module of the CPU directly via an internal bus.

3.2.4.5 Firmware

The firmware of the CPU is designed in a similar manner to that of the wearable box. The programme incorporates three modes, as in the CWB, although no acceleration is being

acquired in mode 1 as the necessary hardware is not included. In all modes, however, the device awaits events from either the bed sensor (mat pressed / mat released) or door switches (door opened/door closed) received via the radio interface. Once such an event is detected, a notification is transmitted straight to the host connected via Bluetooth using the same framing protocol as in the case of wearable data.

Handling of remote control events posed a different problem. As stated before, the format of binary commands sent by a remote control depends on the type of equipment, manufacturer etc. Therefore, it is impracticable for the CEB to interpret the binary sequences and distinguish between particular commands (e.g. switching channels or volume control). Instead any command (binary sequence) received is interpreted as a single “remote event” and is treated within the firmware in a similar manner as other events (i.e. doors and bed use). Such a solution allows gaining insight into entertainment equipment usage as well as speed of pressing buttons whilst remaining generic in terms of compatibility with various makes of remote controls.

3.2.4.6 Enclosure and power source

As the environmental box was designed to be stationary within a home environment, it was decided that the main power source of the device would be a standard mains supply, thus removing the need to charge and maintain a battery.

The box containing the main processing unit, light and microphone circuits and the 433MHz radio does not contain the IR receiver which is instead connected via a cable. The premise being that the smaller IR receiver can be placed in a more preferable position in terms of exposure to remote control signals.

3.2.4.7 Environmental box monitor

The environmental monitor is a desktop computer application developed in the Java programming environment to facilitate data acquisition from the custom environmental box via a serial Bluetooth link. The application ensures that all data is acquired regularly switching between the two acquisition modes (microphone or light detection) of the environmental box at a rate possible to specify in the configuration. All information is stored in the file system and also displayed on the screen for the user or system administrator to inspect (Figure 3-11).

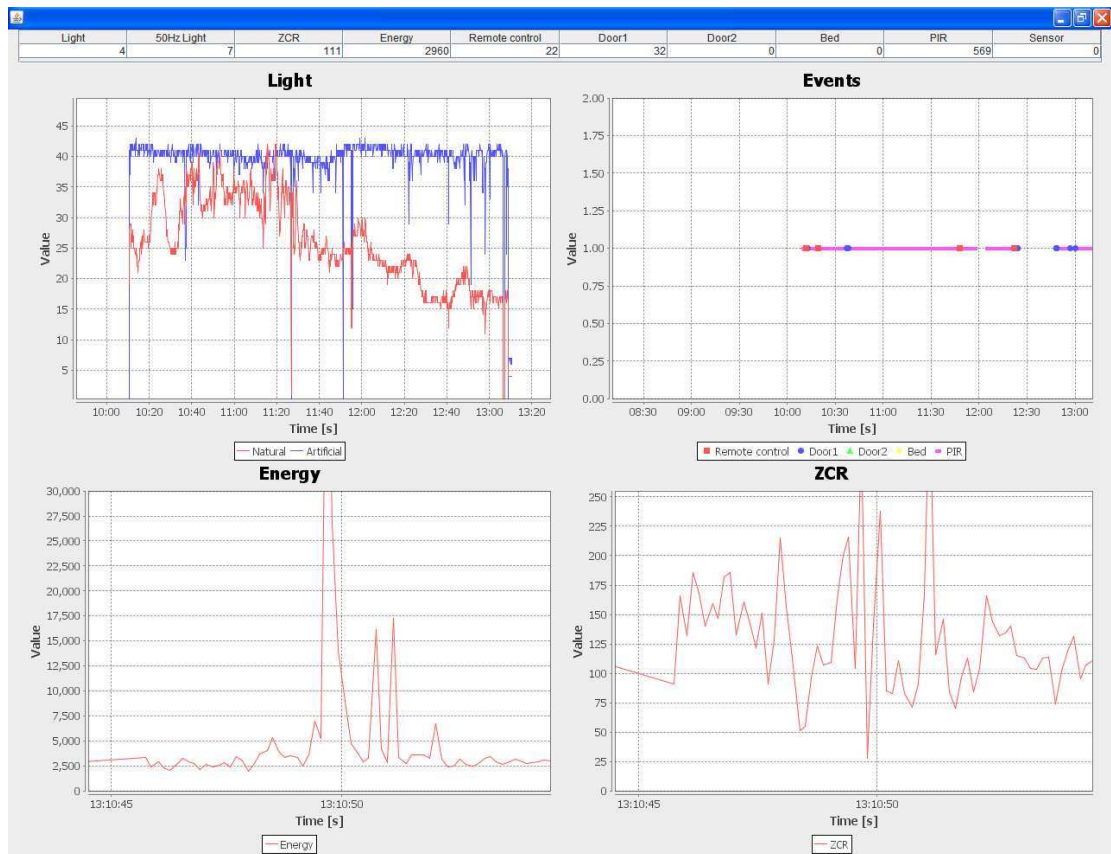

Figure 3-11 The graphical user interface of the environmental monitor

3.3 Validation procedures

The development of each sensor described above was followed by a validation procedure ensuring that the particular sensor is collecting the desired type of data. As the overall aim of the PAM platform is to appraise changes in behaviour and patterns of the user, calibration of absolute values provided by the sensors was not performed. The following paragraphs briefly describe the validation steps performed before deploying the prototype sets according to the PAM project schedule.

3.3.1 The accelerometer

The configuration of the acceleration sensor in terms of amplitude range and frequency spectrum was done in accordance with suggestions found in the literature [24]. Additionally data provided by the accelerometer integrated in the CWB was validated against an off-the-shelf wearable device with similar properties. The process was performed by the University of Southampton research team, as the initial investigation in processing accelerometric activity data was performed there using an MSR 145 datalogger.

The investigators performed several activities, classification of which was researched in their previous work [98], using both the CWB and the MSR and performing similar analysis. Since the data obtained from both devices did not exhibit any major differences, the CWB accelerometer replaced the off-the-shelf device in further research.

3.3.2 Light sensors

In order to validate the light sensors designed as part of the CWB and the CEB, the sensor was subjected to several tests. The general light sensor was carried in alternating weather conditions and sunlight exposure. The effects of these tests allowed to fine-tune the

gain ratio of the amplifying circuit preventing the saturation of the sensor under the majority of exposure conditions. The artificial light detection technique was tested by placing the sensor under different types of lighting from traditional incandescent light bulbs to modern energy efficient fluorescent lamps. In all cases the light level reading in arbitrary units ranging from 0 to 255 stood in agreement with subjective human-made appraisal of the artificial light intensity.

3.3.3 Microphones

As described earlier, the selection of temporal auditory features (i.e. ZCR and STE) collected by the CWB and CEB microphone was based on reviewing established methodologies of sound analysis [90,99]. The microphone was then tested in three general scenarios: musical, human speech and replayed recorded human speech. The values of ZCR were considerably low for human speech and higher for music. During the quiet periods (i.e. when STE values were low) ZCR oscillated around a baseline value higher than during human speech. Such behaviour of ZCR and STE values was similar to expectations based on other work [99]. However, no further deep analysis and validation of the sensor was performed.

3.3.4 Binary environmental sensors

The validation of binary environmental sensors (i.e. door switches, bed sensors and remote control monitor) was limited to testing the sensitivity of the wireless transmitters to distance from the receivers and its influence on number of missed events. The remote control monitor was tested against several brands of remote controls. As described in detail further in the results section, there was no validation of the bed usage sensor against any sleep

monitoring methods as additional sleep related features of the output were only discovered during the user trials.

3.4 Mobile phone software

In the prototype PAM scenario the sensor gateway nodes are appliances of everyday use. In the case of the wearable set it is the mobile phone, whereas the environmental sensors connect to a desktop PC. Both appliances need to be customized with appropriate software to interface the sensors and process, store and back up the data which then can be used further. The software enabling the PC to work as a node was described section 3.2 regarding the environmental sensors. The following sections will describe the bespoke software suites that enable the mobile phone to work as part of the PAM scheme.

Most current mobile phones allow developers to create custom software suites that can interact with the user, store data on the device, access internal hardware, pair connections to external devices via Bluetooth or connect to global networks via packet transmission protocols. Depending on the manufacturer, operating system and hardware capabilities developer's access to some resources is limited or denied altogether. Therefore, the first step of designing PAM mobile software was to establish the access requirements for platforms to be capable of running the suite.

The target mobile platform must allow:

- Access to the main display and to a means of interaction with the user – most mobile platforms allow developers to make applications with their own screens and capturing of user input
- Presence of, and access to, a Bluetooth radio frontend – the suite should be able to pair and capture streams from the wearable Bluetooth sensors.

- Access to storage such as allowing to write files to a memory card.
- Possibility of running the suite persistently in the background with little or no obstruction to the standard phone functions.

Any device fulfilling these conditions can then serve as gateway node in the discussed PAM scenario.

3.4.1 Platforms and APIs

There are a number of diverse mobile phone platforms available on the market. These range from simple proprietary solutions specific for one brand to more advanced universal operating systems (e.g. Android) which can be found on devices from various manufacturers. Each of these comes with a set of available application programming interfaces (API). Many of the APIs are supported by a number of platforms, a fact which allows the creation of (to some extent) generic applications able to run on a wide range of phones. The main API solutions considered for the prototype implementation are listed in the table below.

Table 3-5 Programming interfaces and devices

API	Programming language	Supported by
Java micro edition (Java ME) APIs	Java	Most proprietary platforms found on mid-range phones from major manufacturers including Nokia, Sony Ericsson, Samsung, LG and more. Devices featuring Symbian Operating System (i.e. most mid and high-range Nokia devices and a several models from Sony Ericsson)
Symbian APIs	C++	Devices featuring Symbian OS
Android API	Java	All Android OS smart-phones. Manufacturers include HTC, Samsung and Sony-Ericsson
iPhone OS API	C++, Objective C	Apple iPhone

The PAM prototype system described within this thesis was implemented using Java ME. This API is the most restrictive among all the considered solutions in terms of providing access to device resources. This is due, however, to its considerable universality which was the main reason for employing Java ME for the purpose. The premise is that solutions developed in this prototype can then be adapted by future users and trial subjects wishing to use their own phone as a base for a PAM system.

3.4.2 Java Micro Edition and its constraints

The core Java ME libraries implemented on the vast majority of phones are bundled in a profile called Mobile Information Device Profile (MIDP) which allows the developer to create applications (called MIDlets) to interact with the user and freely modify the information displayed on the screen. The basic implementation does not, however, allow access to the Bluetooth stack, storage devices or internal sensors. Those functionalities are enabled in extension libraries provided (e.g. JSR 82 enabling Bluetooth communication). Some manufacturers choose not to support these in all (or some) supplied phone models limiting developers to the basic MIDP features. This, however, applies mainly to low-end devices with limited processing capability. Due to privacy restrictions – none of the extensions provide the developer with a means of accessing the user's phone log, recording live calls, handling standard text messages or monitoring data packet traffic. However, MIDlets can (with the user's consent) initiate phone calls, send text messages and initiate data transfer of its own.

To ensure a user's safety in using MIDlets there are 3rd party certification systems which allow developers to sign their software if it fulfils safety and security requirements. Without such certifications most platforms require the user to separately authorise most actions

performed within the MIDlet. This poses a problem for applications aiming to work unobtrusively in the background (like the PAM system) as a platform's security prompts require user's interaction. Many devices, however, allow customising such measures to increase the usability. The devices selected for the prototype (named in the Mobile Phone section of this chapter) allow such customisation.

3.4.3 Software Architecture

There are three separate MIDlet suites created for PAM evaluation, each handling a different function:

- PAM Questionnaire – implementing a mood and activity questionnaire designed to get user's feedback as well as validation data to match with sensor readings.
- PAM Transfer – designed to backup and send collected sensor and questionnaire data and send it to the main storage facility (i.e. desktop computer).
- PAM Sensors – the application handling and maintaining communication, acquiring, processing and storage of the data collected.

The first two MIDlet suites were created in the Stirling University whereas the last one was developed by the author of this thesis.

The structure of the PAM Sensors application is illustrated in Figure 3-12 which shows the main classes and libraries used.

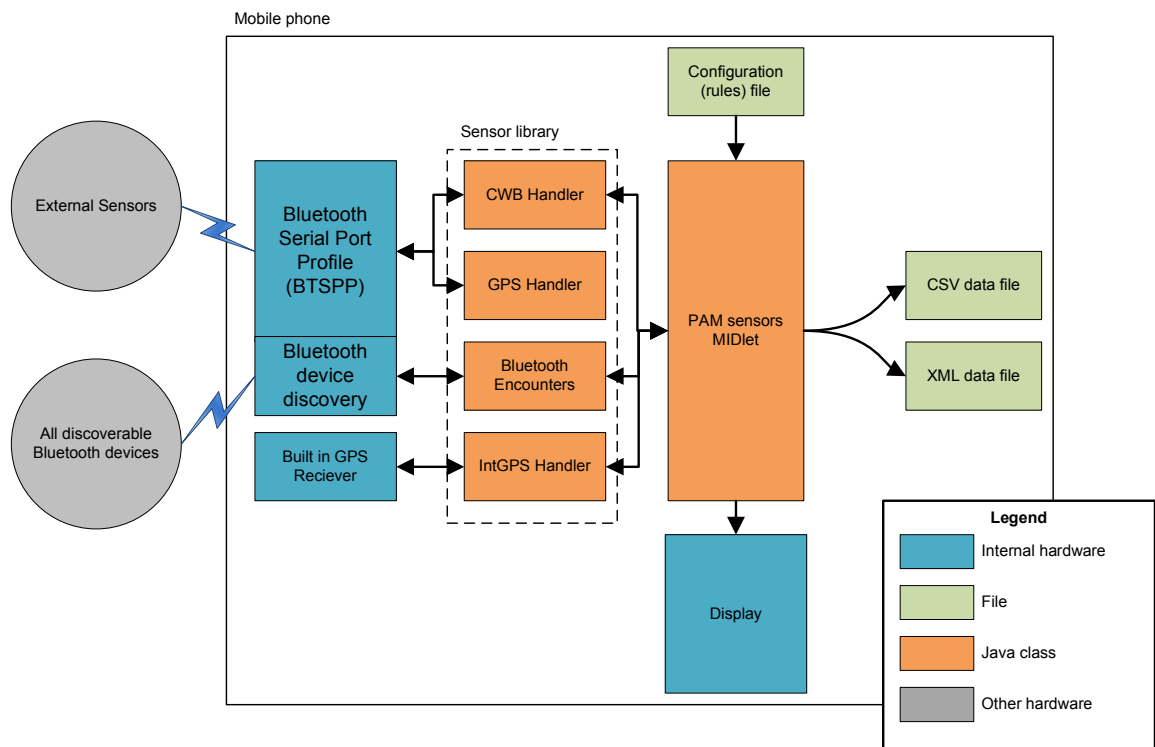

Figure 3-12 The architecture of PAM sensors application

In the scheme the MIDlet first loads a configurations file containing settings for all devices including their connection addresses, desired acquisition frequency etc. The scheme is designed so as this file can be modified according to the rules engine researched in the University of Stirling. However, in the installations described further, the file was fixed to preset values. The application then establishes the connection and sends configuration commands to the devices via device handling classes. The sensors are then activated and start acquiring data and feed it back to the phone where they are processed and passed to the main application by the handling class. The MIDlet then stores the information in one of two implemented file output formats (discussed in the File formats, Section 3.4). The status of the devices and current readings can also be displayed on the phone's screen. This way the user can intervene in case of, for example, a sensor dropping out due to a low battery. The

files with stored sensor data can then be read and processed by other MIDlets to be transferred to the main host by the PAM transfer suite).

3.4.4 Sensor library

The classes implemented as part of the device library are designed to handle the specific sensor protocols and requirements and make them work as part of a common framework. This means that even though the internal GPS receiver has a different communication routine than the Bluetooth-connected custom wearable box, they are handled in the same manner and using the same set of software methods by any client application using the library.

The library uses different resources to acquire sensor data. For Bluetooth enabled external sensors (i.e. GPS receiver and CWB) the framework utilises the Bluetooth serial port profile to stream commands and receive data in return. In the case of handling the internal GPS device, the library uses the extension to the standard Java ME API (i.e. JSR 179) which is designed to handle internal location providers. The realisation of the Bluetooth encounters monitor is achieved using the main Bluetooth stack to discover and store information on all devices in range. The purpose and specifics of the implementation is covered in the Chapter 5.

3.4.5 User interface

The user interface of the PAM sensors MIDlet is designed to give basic feedback on data currently being acquired as well as provide the user with basic control over the monitoring process. The graphical interface communicates the connection status and current sensor values acquired. The user can pause or shut down the monitoring process altogether. In order to enable the user to use the standard functionality of the phone whilst running the system, the MIDlet can be minimised to work in the background.

3.5 File formats

The proposed PAM prototype assumes the need to store large quantities of non-uniform data. Therefore there was a necessity to develop a unified standard file format which would allow the storage of data in an integrated manner whilst maintaining the differences in quantities and types of information stored. During consecutive stages of development two formats were utilized.

3.5.1 Comma Separated Values (CSV) format

This popular format for storing data was used in the initial stages of development. In this scheme data entries separated by commas are stored in a text file in rows. The consecutive columns contain in order: date and time of measurement, one letter tag describing the type of measurement (for example letter A for Acceleration readings) and finally reading values separated by commas. Example lines from such a file are as follows:

```
26.10.2010 13:23:33,L,33,12,  
26.10.2010 13:23:34,A, -0.9775,0.2737,0.1565,
```

The first line indicates a light detector reading of 33 for general light level and 12 for artificial light. The second indicates the acceleration in three separate axes. Such data organisation was used for initial data collection as it was easy to analyse and process for specific values. However, trials involving more participants and sources of data called for a more sophisticated means of data storage.

3.5.2 Extensible Mark-up Language (XML) file

A specific XML scheme for a PAM scenario was created at the University of Stirling to facilitate data collection in a trial involving multiple users as well as multiple sources of data

of similar type. The format organises data using tags with fields allowing the specification of the source user, type of device and its location for every reading set. The format can be expanded into data structures more complicated than simple sets of numbers. Below is an example of readings being encoded into a XML format:

```
<reading_set message_type="GPS" entity="ext_GPS"
entity_instance="jmb_gps" frequency="10" location="W"
id="1235470327824"/>
<reading ref="1235470327824">52.1211,-1.2133,0</reading>
<reading ref="1235470327824">52.1211,-1.2133,10</reading>
<reading ref="1235470327824">52.1211,-1.2133,20</reading>
<reading ref="1235470327824">52.1211,-1.2133,15</reading>
```

Where:

- message_type denotes the type of data (e.g. Accelerometer, GPS or other reading)
- entity denotes the type of sensor (as same message type could come from different types of sensor)
- entity_instance allows one to distinguish between multiple instances of the same sensor in the same set-up and also allows to identify the user (i.e. user jmb above)
- frequency specifies the frequency for multiple consecutive readings without a separate timestamp
- location is the information about the location of the sensor (in the example above “W” means wearable).
- id: used to reference a <reading> element and denotes a time when the reading was taken in UNIX time format.

Consecutive readings inside the `reading_set` are placed inside the `<reading>` tag with the `ref` field denoting the id of a corresponding `reading_set` header. The timeline of readings can be derived from the initial timestamp (`id`) and the frequency also specified in the header.

The detailed schema as well as references to the XSD scheme, both created in the University of Stirling, can be found in the appendix

3.6 Summary

The chapter presents a detailed description of every device and sensor included in the initial PAM prototype. The sensor types were selected so as to monitor areas likely to be influenced by the course of a mood disorder.

The sensors can be divided into two groups regarding their target location: environmental i.e. placed in the user's home and wearable i.e. worn or carried by the user during the day. The first group utilises a stationary computer equipped with commercial and custom-designed software acting as a processing node and storage facility. The latter sensor group is based around a customised mobile phone serving as a processing and storage node. Moreover, in this scheme the phone transfers collected data to the computer for backup.

The wearable sensors consist of an off-the-shelf GPS receiver and a custom-made wearable box (CWB) containing a 3-axis accelerometer with parameters adjusted to observe body movements, light detector capable of distinguishing artificial light and a microphone. Both the GPS receiver and the CWB are Bluetooth enabled to stream data to the hub mobile phone. The phone's software was modified in order to acquire, process and store data from the described devices achieved via a custom-made Java ME applet designed for Java-capable phones.

The environmental set contains several separable subsystems: Wi-Fi Camera processing for activity in pre-selected AOIs, PIR motion detectors interfaced via X10 protocol and Bluetooth enabled CEB containing light detector, microphones as well as door switch sensors and remote control monitor connected to it.

The prototype described in detail within this chapter was afterwards put to a series of trials designed to determine the usability of such a system in a pervasive monitoring scenario. The outcomes of these trials are described in the following Chapter.

4 Technology trials

This chapter describes the trials and testing procedures of the PAM prototype whose development was described in the previous chapters. First, the methodology was put to the test in a technical trial involving healthy volunteers in order to establish the usability and identify any fundamental design flaws that may occur. The following phase was to interview and recruit potential bipolar patients who were willing to test the proposed solutions. The general results of the tests as well as the performance of sensors created as part of the presented PhD project are discussed within.

4.1 Ethical procedures

Both trials were reviewed by an ethical committee. The first technical trial that did not involve patients suffering from the condition was granted ethical approval by the Faculty of Engineering Ethics Committee at the University of Nottingham. An information sheet and consent form were provided to all participants of the trial.

The next stage of the trial, which involved BD patients, required approval by a central ethical body: the UK Research Ethics Committee and NHS Research and Development office. The process of seeking such approval was led and carried out by Prof. Sally Brailsford from the University of Southampton on behalf of all researchers participating in the PAM project.

Both of the applications included the proposed use of all the sensors described in the previous chapter enabling the entire system to be tested. Both proposals were positively appraised and permission to go ahead with the trials was granted in March 2009 for the technical non-patient trial and March 2010 for the trial involving patients.

4.1.1 Recruitment constraints

Both ethical approval applications outlined constraints regarding who could participate and so be subjected to monitoring using the devised techniques. The first trial as described below focused on evaluating the system from a technical point of view. Therefore, ethical approval was sought for testing it on the investigators themselves and carefully selected individuals who could provide a useful insight in terms of its usability and technical issues.

The patient trial, where the ethical approval was granted by the Research Ethics Committee, listed specific exclusion criterion. To ensure that the consent given by potential participants was fully informed, they had to be in neither the manic nor depressive stage of their bipolar cycle. This was to be confirmed by their lead care giving clinician. The participating patients also had to be free from other mental or serious physical conditions.

4.2 Technical trial

Before the designed and developed PAM prototype could be put to use in its envisioned application it was decided to perform a technical trial on a group of consenting non-patients . The main aims for the technical trial were iterated as follows:

- Testing the reliability of the technology: ensuring that the devised prototype is capable of long-term data acquisition and that storage and sensor drop-out due to technical malfunctions were not a major issue in the monitoring process.
- Investigate possible improvements to the integration of the technology: detecting any conflicts between devices, protocols and communication links used by multiple sensors and nodes within the system.

- Detecting user compliance issues: identifying any areas where a non-skilled user might not be able to follow usage instructions and procedures as well as finding devices that might not be used because of their obtrusiveness in daily life.
- Surveying the acceptability of the system: testing which sensors and devices might cause discomfort or privacy concerns for the user over an extended period of time.
- Acquiring initial data for further development of processing algorithms: collecting activity data and utilising it to devise a methodology of processing it to extract key features that could indicate a change in behaviour patterns. The data could then be used as a control sample in the further trials involving patients.

All trials were performed on a group of four male adults from June to November 2009 and were followed by a reassessment meeting which led to further modifications to the system.

4.2.1 Setup

The main setup of the trial consisted of the elements described in the previous chapter. The devices were designed either for installation in a home environment or to be worn comfortably by the participants. Table 4-1 shows the final configuration of each identical set of devices constituting the prototype PAM system. However, some of the custom-made devices were also tested separately in order to fine-tune their configuration and parameters. The results of those procedures were also taken into consideration in the overall trial.

Table 4-1 List of devices for the PAM technical trial

Wearable	Environmental
Nokia 6120 Navigator	MS Windows operated desktop computer
Custom Wearable Box (belt worn)	Marmitek CM15Pro X10 USB interface (for PIR sensors)
Bluenext Bluetooth GPS receiver	Two Marmitek MS13E2 PIR motion detectors
	Edimax IC-1520DPg wireless camera
	Custom Environmental Box
	IR remote control receiver
	Bed pressure mat and transmitter
	Two door switch sensors

Nokia was the only type of phone utilised in the trial in order to maintain the uniformity of setups. All of the elements of the kit are presented in Figure 4-1.

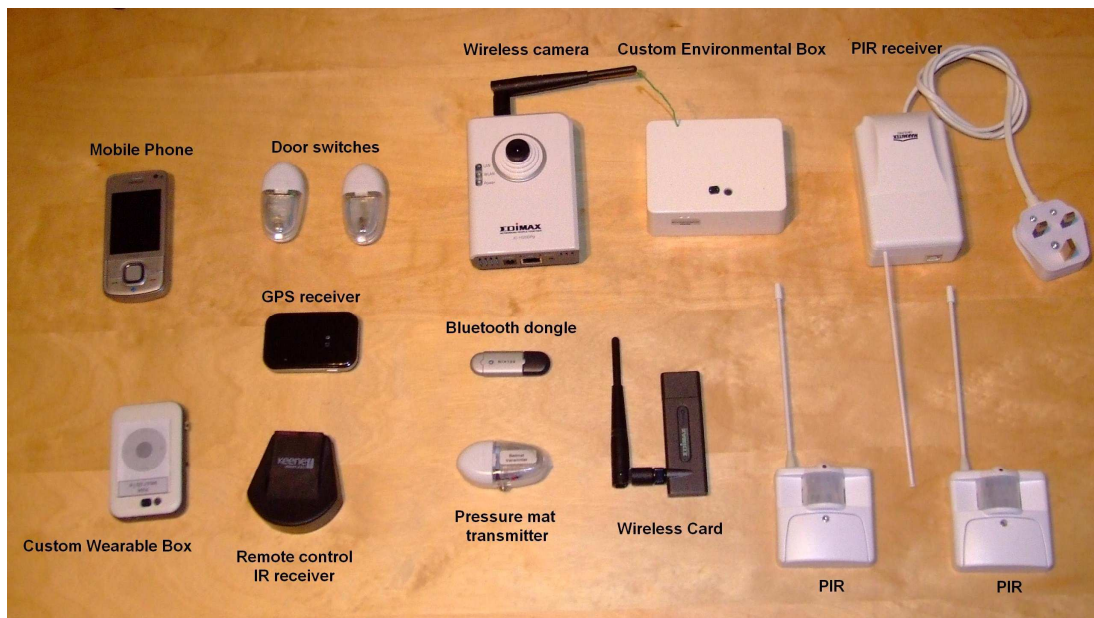

Figure 4-1 The PAM prototype kit

4.2.2 Participants

A total number of four subjects were monitored at various stages of the trial. The participants of the technical trial were recruited from among the researchers involved in the project. The reasoning for such an arrangement was that the trial objectives were mostly technical and could be addressed more efficiently if the user had an in-depth knowledge about the system. All participants were interviewed and gave consent according to the established procedures.

4.2.3 Collected data

One of the main objectives of the trial was to observe the performance of the sensors as well as to assess their potential for monitoring behavioural patterns. Therefore the collected data was pre-analysed in order to determine whether the particular sensor carried information about behaviour that may be fed further into a processing algorithm being developed by other research partners in the PAM project. Such data could also be used for developing a standard behaviour model which then could be compared to a disturbed one in case of a BD patient.

4.2.3.1 GPS tracking

The first main performance-related observation regarding the GPS tracking made throughout the trials was that the internal GPS of the Nokia is much slower in establishing satellite links compared to an external receiver. Therefore it was decided that the Bluetooth receiver would be the preferred medium for obtaining GPS readings.

As expected, all the collected GPS datasets had similar features: clusters of points around significant locations (e.g. home) with these clusters then connected by tracks where the recorded speed indicates motion. The tracks were consistent with the transport infrastructure

and travelling habits of the participant. Figure 4-2 shows an example GPS dataset coded for speed plotted on a map. An attempt at an in-depth analysis of the GPS data in conjunction with other inputs is presented in Chapter 5.

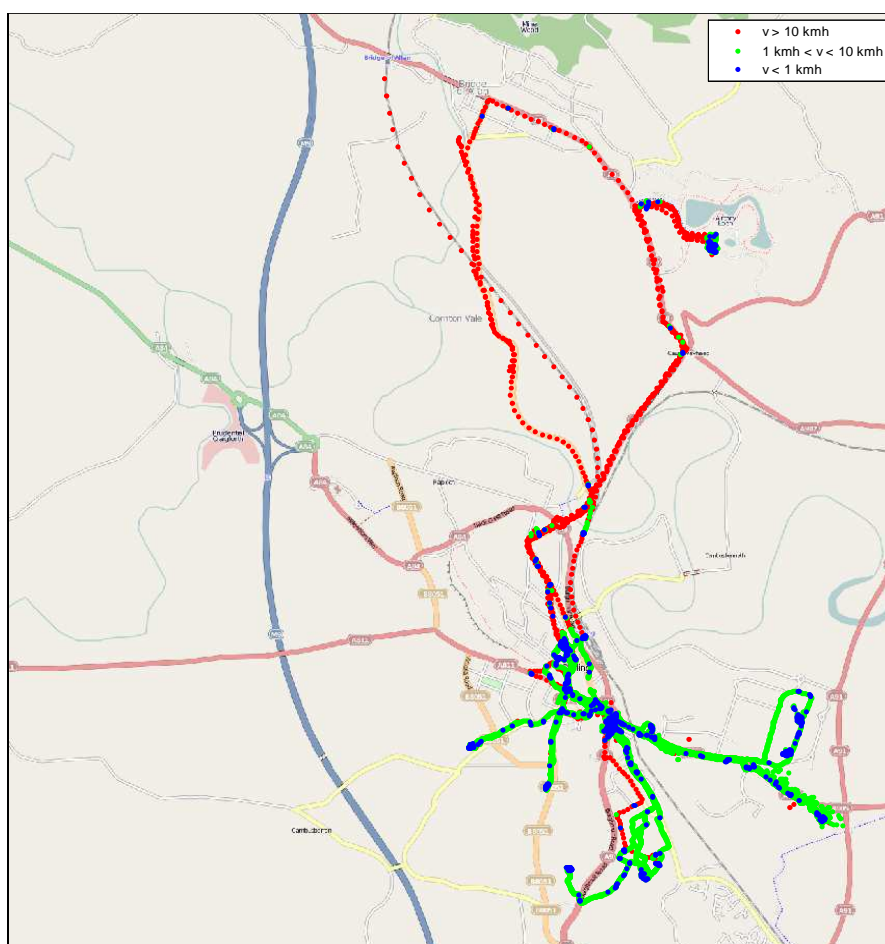

Figure 4-2 GPS tracks characterised by speed

4.2.3.2 Bluetooth encounters

During the initial stage of the trial it was discovered that due to a memory leak occurring on Nokia phones the Bluetooth encounter monitor was causing the entire node to malfunction. Therefore, it was decided that this input should be excluded from the trial procedures. The fault was then rectified and Bluetooth encounters were utilised in conjunction with GPS data in a separate trial described in Chapter 5.

4.2.3.3 Acceleration

Undoubtedly accelerometers are the most widespread and convenient way of monitoring overall physical activity [24]. The belt-worn accelerometer utilised in the technical trial, as expected, provided informative data about the subject's activity. To illustrate this, the raw data from long-term monitoring was subjected to basic processing to assess the user's activity. The methodology was similar to the established ways of appraising activity [24,100].

An example of three-stage processing is illustrated in Figure 4-3. The first stage was to combine three axis data (a) into the acceleration vector magnitude (b). Secondly, digital high-pass (with a 0.1Hz cut-off) filter was applied to remove the constant gravitational component (c). In the third stage the data can be rectified and integrated over a certain time (d). The resulting curve is then considered proportional to the user's physical activity/

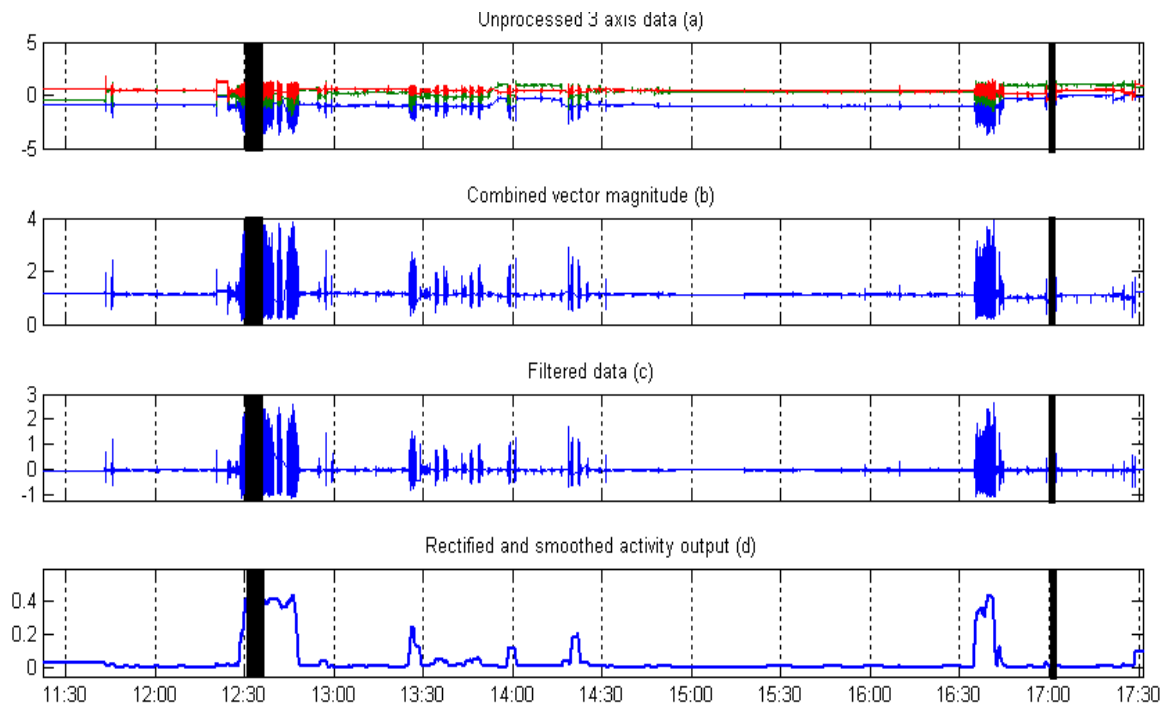

Figure 4-3 Processing steps of acceleration data. Periods of temporary sensor dropouts are blacked out.

Integrating activity over a period of an entire day provided a measure of overall activity during a day [86]. Figure 4-4 shows such aggregated activity over the course of two weeks. Missing bars represent days where the sensor was not worn (amount of data was insufficient), activity could not be appraised. Nevertheless, the differences in activity of the user can be observed. In particular the user-reported Sunday workout on 09/12 is apparent.

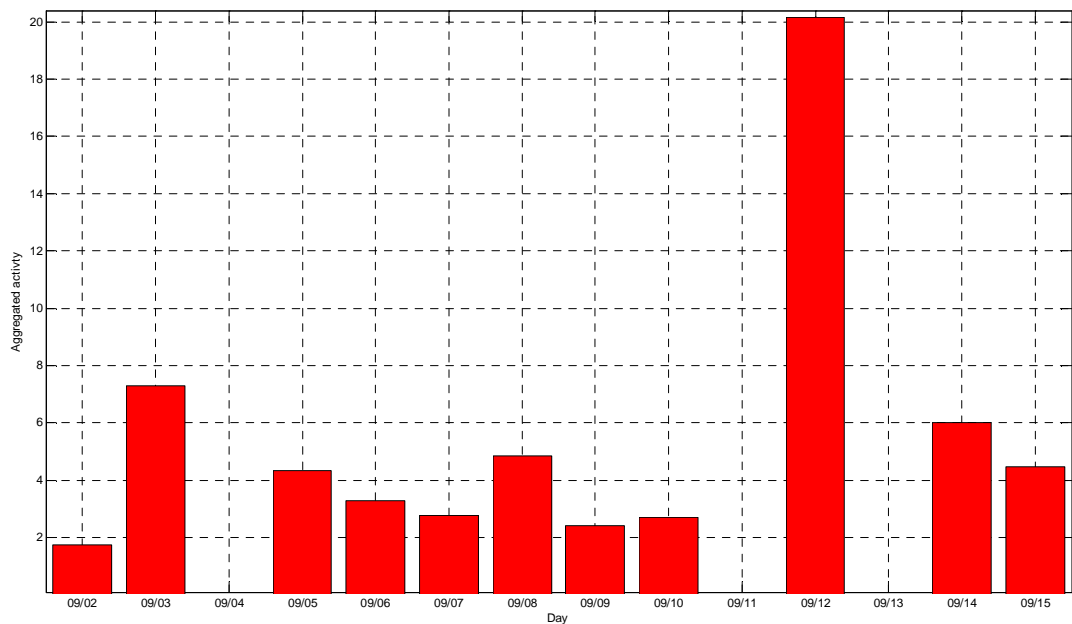

Figure 4-4 Aggregated user activity

A more in-depth analysis of acceleration along with all other inputs collected during evaluation of the PAM project was performed by researchers at the University of Southampton.

4.2.3.4 Light sensors

As previously outlined, light level sensing was performed in both of the monitored contexts: wearable and stationary in the home. The data obtained from the environmental home setting exhibited a significant amount of periodicity as shown in Figure 4-5. Considering the stationary positioning of the sensor, this is due to the day-night rhythm of

the sunlight (apparent in general light readings) as well as the user turning the lighting on during insufficient daylight (observed in the artificial light level). The former provides an insight into hours of daylight actually reaching the participant (an important factor in course of BD [88]), the latter indicates action performed by the user and provides the opportunity of detecting changes in circadian cycles – one of the key areas affected by the disorder [75]. Both readings were prone to fluctuate as the view of light could be temporarily obstructed by people moving within the sensor area or the use of curtains.

Figure 4-5 shows natural daylight cycles with apparent peaks during mid-day. The artificial light trace shows times when the participant turned on the incandescent light during periods of insufficient sunlight.

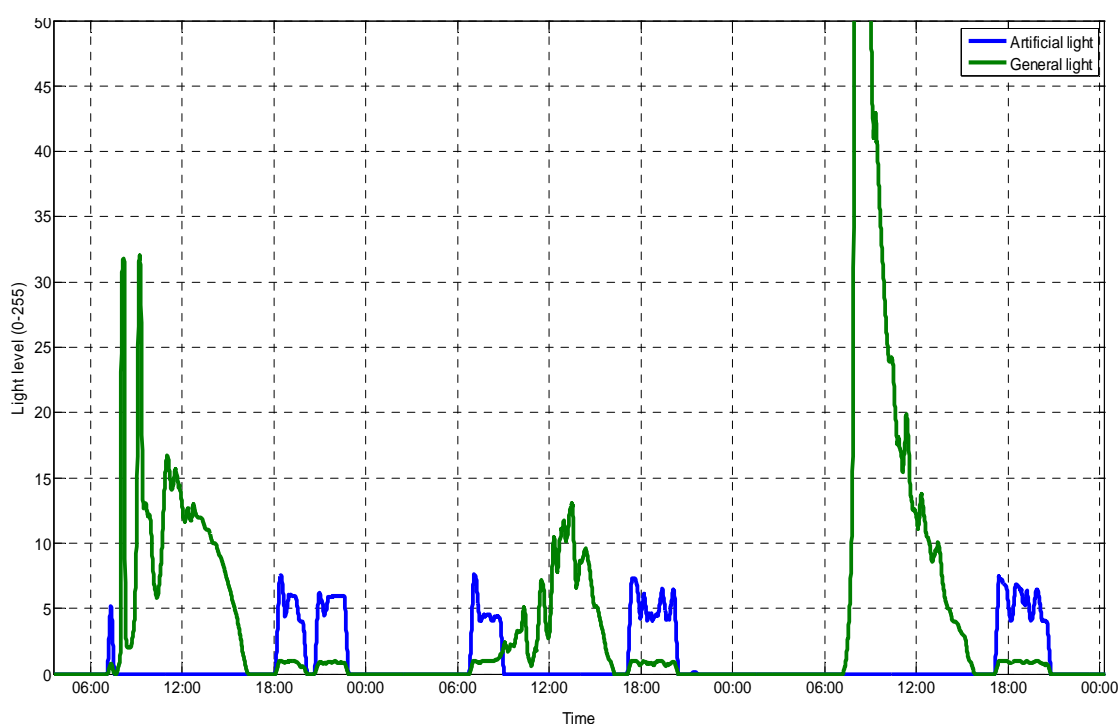

Figure 4-5 Example environmental light readings over a period of three days

The wearable light sensor readings were mainly characterised by periods of higher levels of general (natural) light levels, which can be accounted for by the user being outdoors in

direct sunlight, and periods where dominance of artificial light is apparent, which indicates the user's presence indoors. This dependence can be observed when data is presented against user self-reports. An example of such is presented in Figure 4-6.

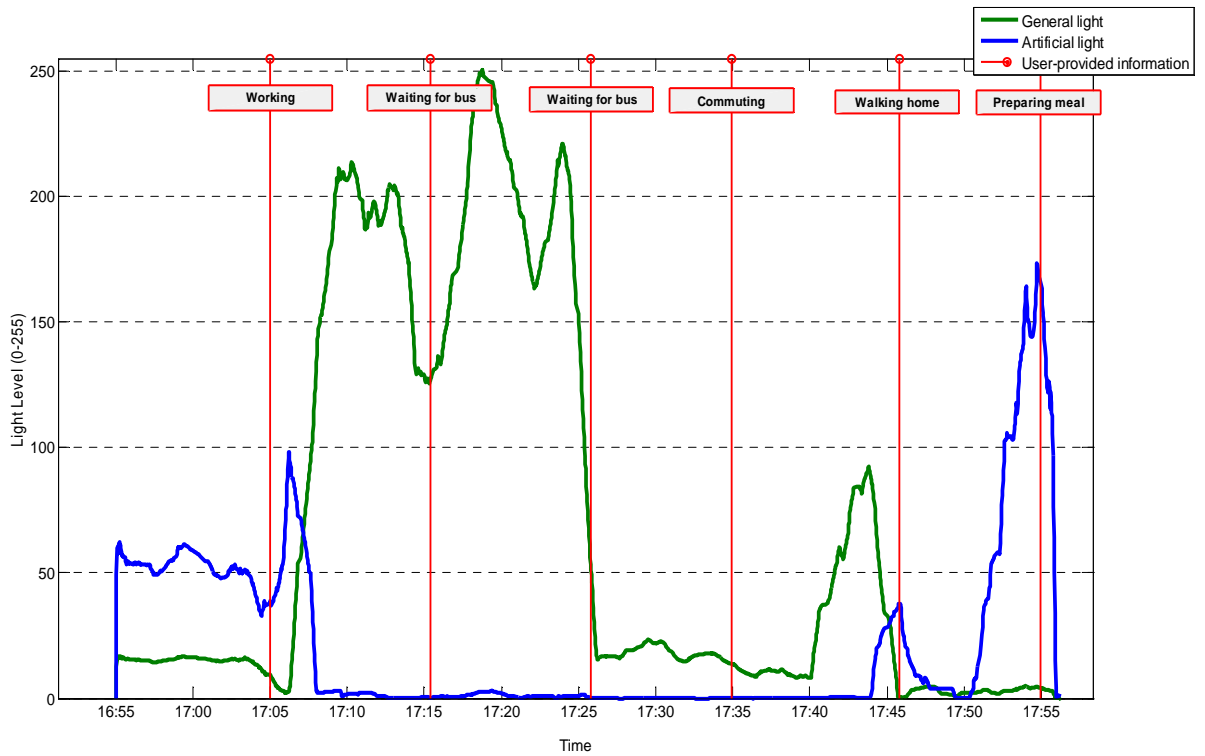

Figure 4-6 Wearable light sensing data during a day with user-given captions

The main compliance issue reported by all participants of the study was the fact that the most comfortable placing of the wearable box (usually on the belt or in the pocket) meant that the light sensor could be concealed throughout the day depending on the clothing worn. The issue was escalated when weather conditions required more clothes to be worn and obstructed the view of the sensor even more.

4.2.3.5 Microphone

As described in Chapter 3, there were two audio temporal features monitored by the microphone: the STE (Short Time Energy) and the ZCR (zero crossing rate). Similar to the

light sensors, the microphone circuit was deployed in both the wearable and environmental settings.

The ambient sound properties obtained from the environmental sensor were consistent with the overall activity in the monitored area as reported by the participants (the typical placement was the living room). The STE values show apparent peaks in the mornings and afternoons when most in-home activity occurred. Figure 4-7 shows comparison of STE readings between two participants. To increase readability of plots the values were subjected to smoothing with a moving average filter with a 15 minute wide window. In the presented day, it can be observed that the STE value for the first participant exhibits more regularity with morning and afternoon peaks of audio energy whereas readings from participant two show less structure indicating less scheduled lifestyle during this day.

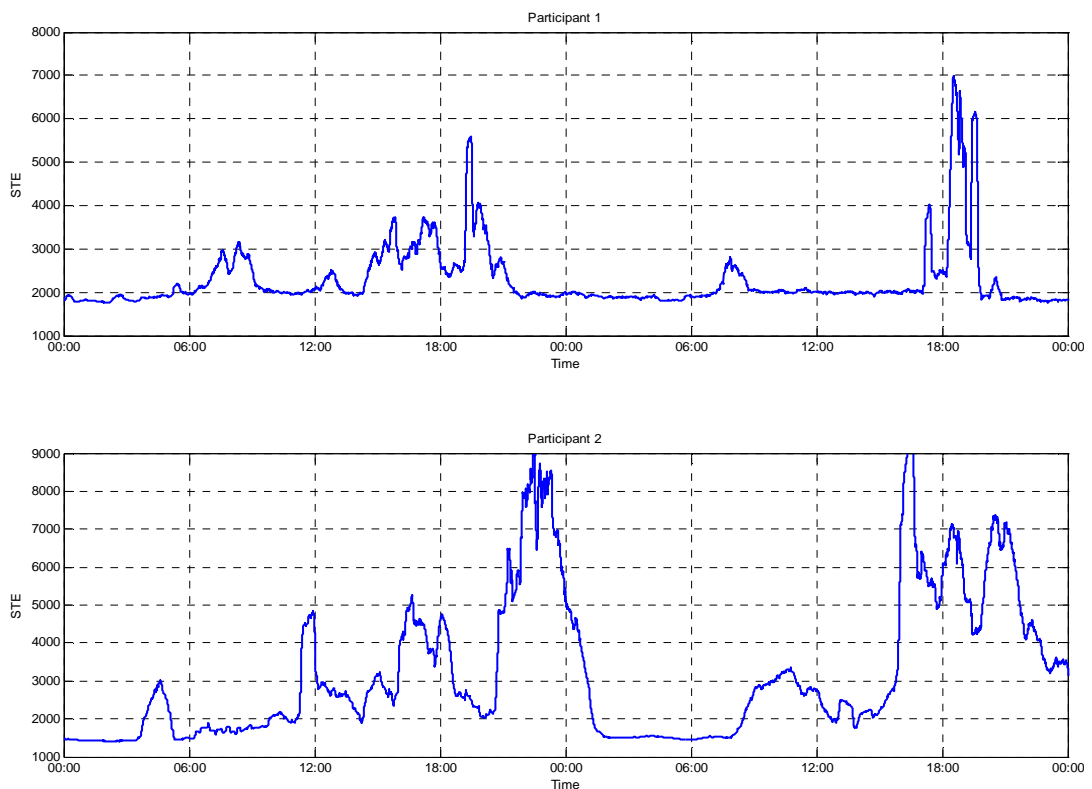

Figure 4-7 Example smoothed STE readings from two participants

The interpretation of ZCR is not as straightforward as STE. In general terms, ZCR provides a rough indication of the dominant frequency of the audio. However, most algorithms for deriving information about the detected sound use ZCR without converting it to a frequency value [99,101-104]. It has been shown that ZCR combined with STE, with appropriate processing and using no other sound features, can be used to distinguish between speech and music in a sound sample [99].

During the “silent” periods (when STE values were low) the ZCR exhibited an unstable baseline typical of white noise as there was no dominant pitch in the recorded sound (as seen in Figure 4-8). However, as energy increased, the ZCR values changed significantly in relation to the established baseline indicating a shift in the pitch (Figure 4-8). The rough interpretation of this is that high values of ZCR indicate multiple frequency components (as for example in music) whereas the human voice is characterised by lower ZCR values [90,99]. This can be observed in Figure 4-8 showing smoothed values of ZCR and the corresponding STE plot.

The wearable version of the microphone provided the similar features from the immediate surroundings of the user. As with the environmentally set sensor the features can be fed to a processing algorithm allowing the derivation about the nature of the audible environment [99]. However, the sensor was, to some extent, affected by the same problem as the light detector as constricted position of the sensor affected the quality of obtained data.

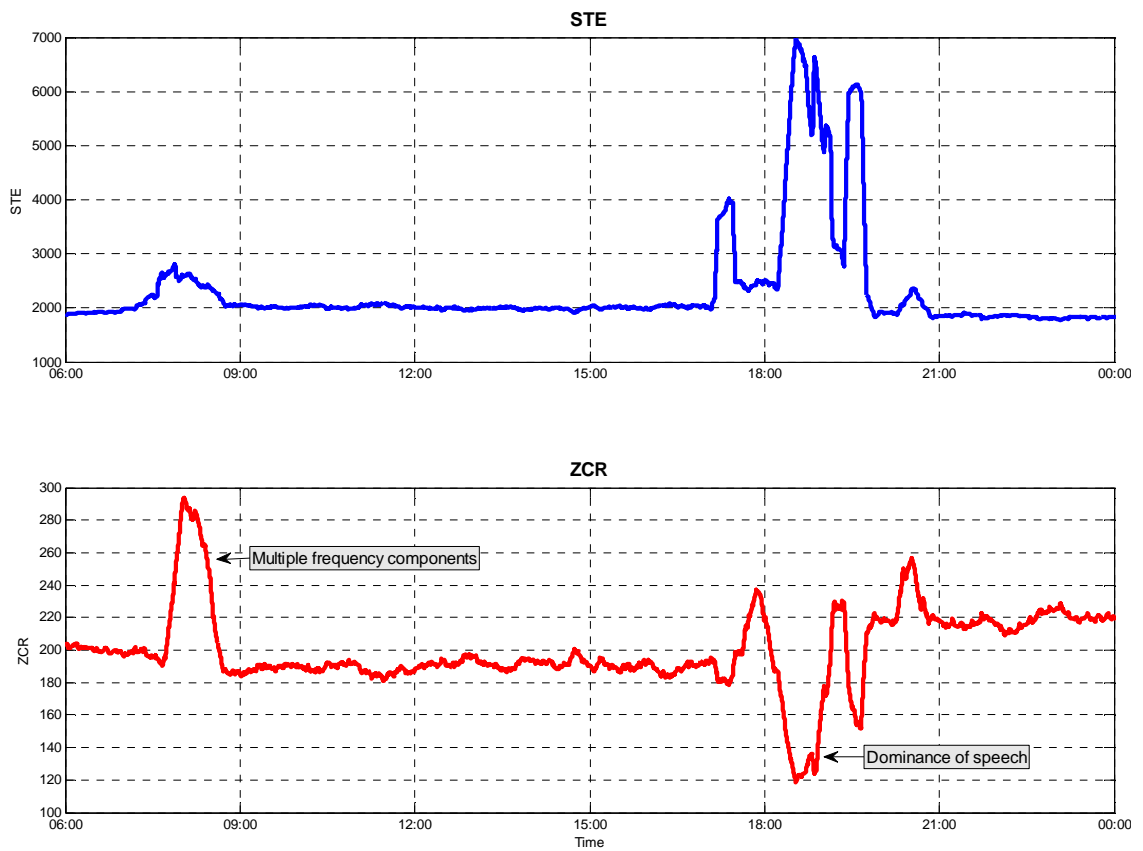

Figure 4-8 Example ZCR readings in relation to STE

4.2.3.6 Environmental sensors

The environmental sensors included in the trial consisted of PIR motion sensors, door switches and a remote control usage monitor. Each of the devices was activated by an event (e.g. pressing remote control button) with the exact time of these events then stored within the system. Figure 4-9 shows a set of readings representative of a day of monitoring for one of the participants. Each bar represents an aggregated number of events during a 15 minute interval. In all cases the results corresponded with self-reporting.

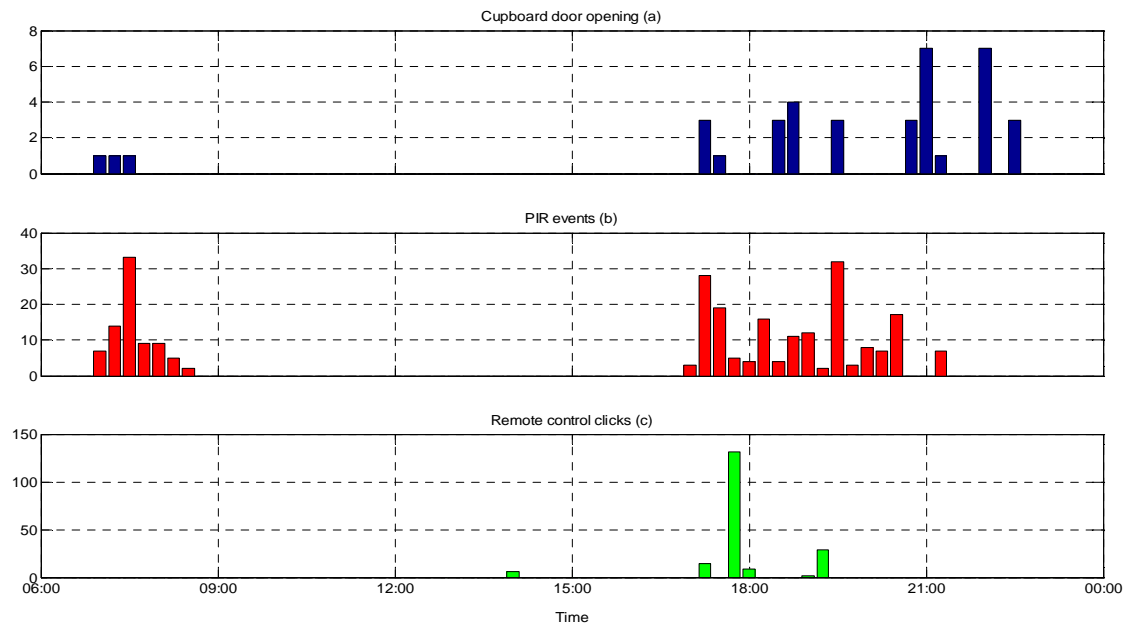

Figure 4-9 An example of aggregated environmental sensor readings over one day.

An attempt at a more in-depth analysis of environmental sensor readings was performed as part of the PAM project by researchers at the University of Southampton. It resulted in successful recognition of daily patterns of the participants.

4.2.3.7 Bed usage

The main aim of monitoring the user's presence in bed was to detect any indication of disturbed sleep. This is vital since for a BD patient the disturbances may be either caused by an episode or alternatively cause an episode itself. The pressure mat was to provide a simple measure indicating the times when the user entered or left their bed.

Due to privacy concerns, only two of the participants agreed to incorporate the sensor in their home. Moreover, one of the subjects reported suffering from stress-related insomnia during the trial, which provided examples of disturbed sleep patterns.

The placement of the sensor was typically under the mattress of the bed underneath the user's centre of mass. A less comfortable placement directly under the sheet was also tested.

All events of pressing the mat (entering the bed) and the release of pressure on the mat (leaving the bed) were logged by the Environmental Box.

One of the first findings that emerged during the evaluation of the sensor was that the output proved to be more complex than simply providing entering / leaving events. The mat used in the trial was sensitive enough to pick up involuntary muscle movements of the user during sleep, causing the mat to be pressed and un-pressed repeatedly resulting in occurrence of on/off events. Although no validation against established somnographic methods was performed, it is likely that the recorded movements can be accounted for by the participant undergoing particular sleep phases.

There are two broad types of sleep: Rapid Eye Movement (REM) and Non-Rapid Eye Movement (NREM). The latter can be then divided into three further stages N1, N2, N3 (also known as deep sleep). Each stage is characterized by different physiological, neurological, and psychological features [105]. A typical sleep cycle lasts between 90 and 110 minutes and the order of stages is usually N1 → N2 → N3 → N2 → REM. The N2, N3 and REM stages in particular are characterised by decreased muscle activity and atonia. In other phases however, some muscle activity may be observed. Excessive movement in the N3 phase may indicate night terrors which often accompany depression [106].

Figure 4-10 shows a typical output of the bed mat from one night with vertical lines indicating each on/off pressed event.

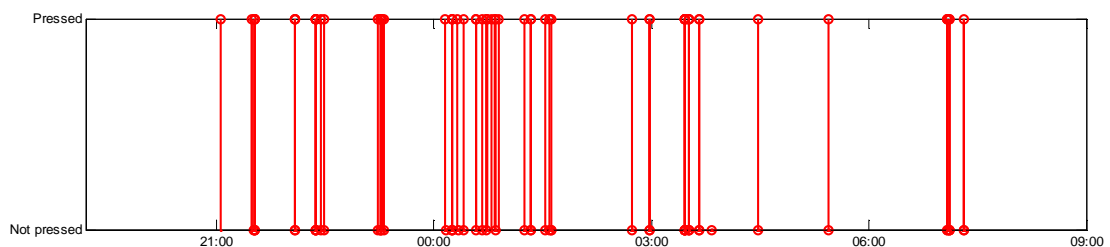

Figure 4-10 Typical bed usage sensor output

This was then processed to produce the double output shown in Figure 4-11. The top figure indicates the derived user's presence in the bed, produced by ignoring rapidly occurring on/off events and not interpreting them as the user leaving the bed. The bottom one shows the number of on/off events which are likely to be caused by the user's muscle activity during the described sleep phases. Each bar represents the number of such events during 15 minute long intervals. The inference of presence in the bed assumes that none of the on/off events would be missed by the node otherwise a missed rapid on event could falsely indicate that the user has left the bed. Therefore for further implementation an additional sensor determining presence should be in order.

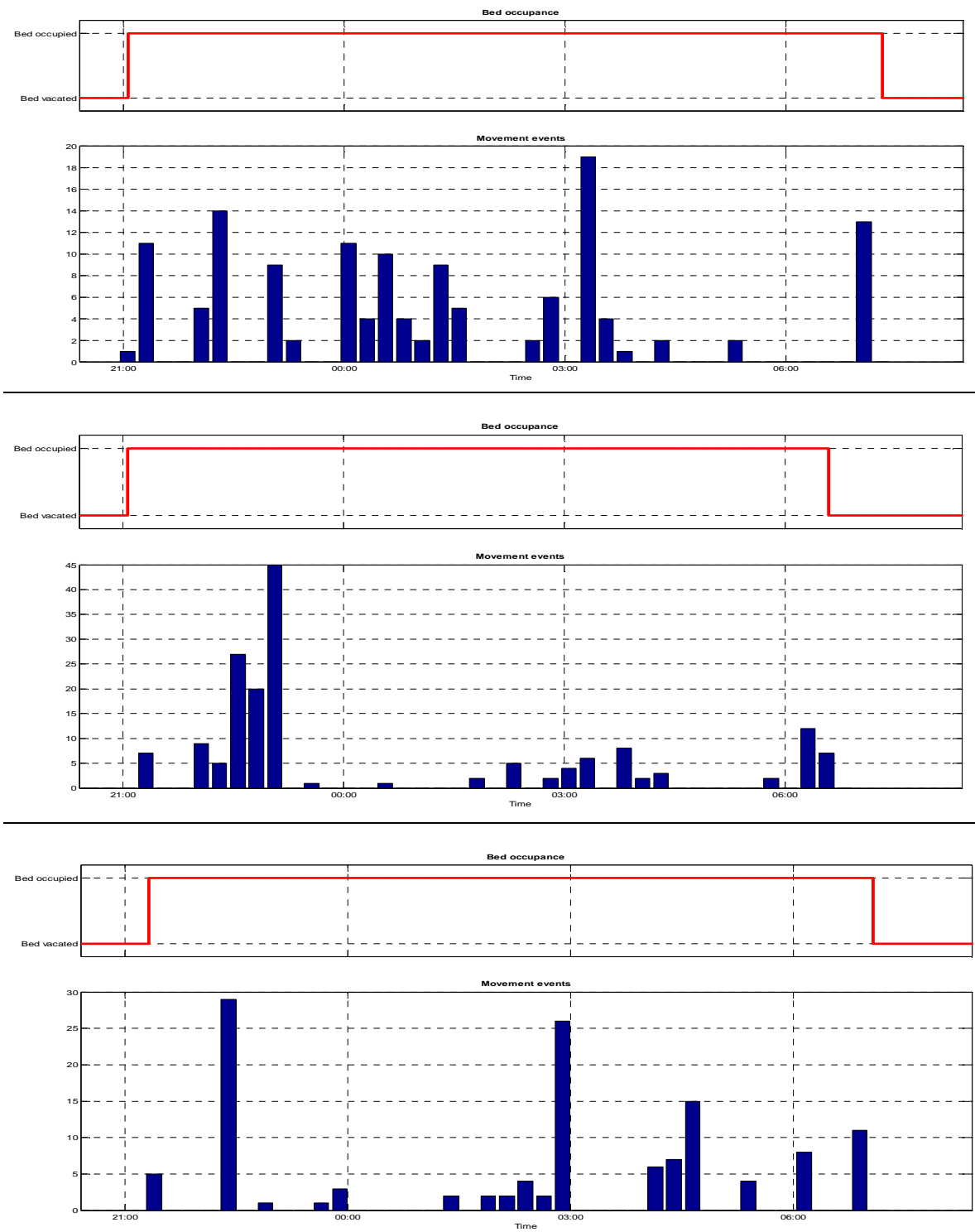

Figure 4-11 – Processed bed usage readings for three consecutive nights of undisturbed sleep. Each pair of figures represents user’s presence in the bed (top) and movement events (bottom) throughout one night.

As mentioned earlier, one of the participants reported that for several nights during the monitoring period they were affected by insomnia and restlessness. This can be observed in the data harvested during those nights. Figure 4-12 presents a disturbed sleeping cycle which shows more movement events indicating increased restlessness (compared with Figure 4-11) and periods when the bed was vacated during the night.

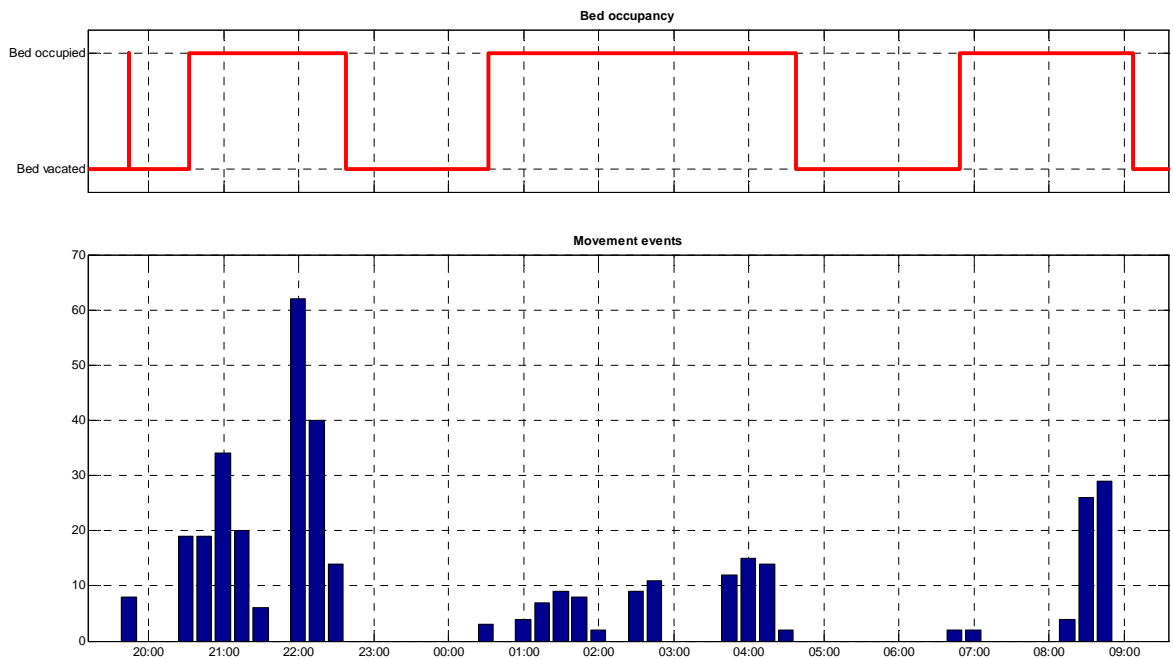

Figure 4-12 – Bed usage readings during disturbed sleep

4.2.4 Post-trial overview of the objectives

The results of the technical trial were used to reassess the proposed monitoring setup taking into account both, the trial objectives as well as the potential utility of the data collected by the sensors as discussed in the previous sections.

The reliability of the sensors in terms of battery life and unexpected drop-outs was very good throughout the trial. Figure 4-13 shows the uplink times (i.e. times when sensors were on and providing data) of particular parts of the system for one of the participants. The

environmental part of the system was functioning without major downtime aside from voluntary shutdown performed by the user.

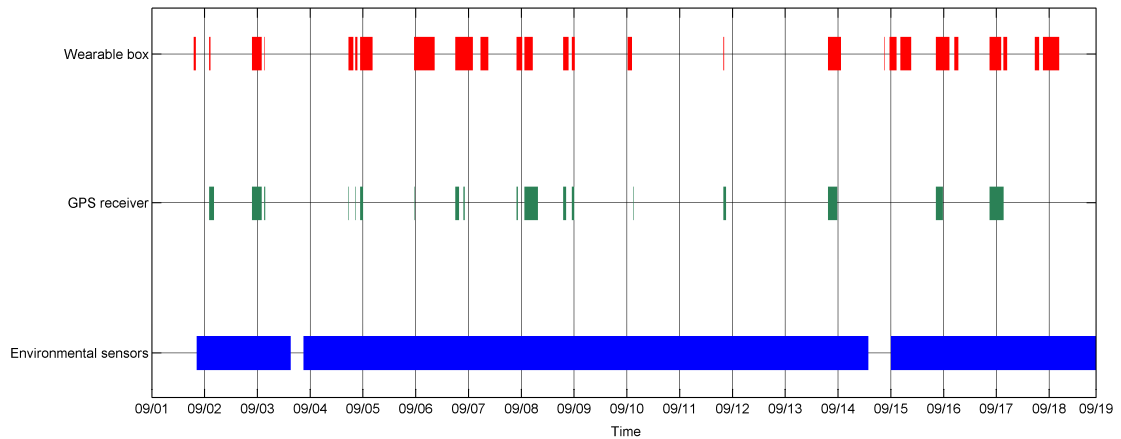

Figure 4-13 Uplink time for PAM subsystems

The wearable sensors, although providing large quantities of activity data, exhibited significant periods of inactivity. This relates to the issue of user adherence as all participating users reported a level of discomfort caused by the number of devices that needed to be carried. The fact that the preferred placement of the wearable node should provide it with exposure to the ambient light sources, only added to the problem. Lower ‘coverage’ of the GPS receiver (in relation to the wearable box) seen in Figure 4-13 is due to two factors. Firstly, the gaps in the plot not only represent times when the receiver was off but also when the satellite coverage was too poor for the positioning to work. Therefore, time spent by the user for example in large buildings appears as downtime of the sensor. Secondly, the typical battery life of the GPS receiver of approximately 6 hours was significantly lower than any other elements of the setup (Table 4-2).

Aside from the GPS receiver, battery maintenance did not cause any nuisance for the users. Recharging procedures were required for wearable sensors and some environmental ones as it was impracticable to power each one from the mains power supply despite their

stationary setting. Table 4-2 shows the typical battery life observed during the trial. The observed times were used to create usage guidelines for future participants of the trial.

Table 4-2 Typical operation time for battery-powered PAM sensors

Sensor	Battery life
Bluetooth GPS receiver	5-7 hours
Custom Wearable Box	More than 24 hours
Mobile phone running PAM	4-5 hours (when using internal GPS) 10-11 hours (otherwise)
Environmental door switches	2-3 weeks
PIR sensors	More than 1 month
Bed-mat transmitter	3-4 weeks

Another major issue discovered that affected the usability of the setup was that all users reported that the routine security questions occurring on the mobile phone were decreasing the usability and user-friendliness of the interface. These prompts are internally implemented by the phone producer (Nokia) to ensure that any user is informed about any actions attempted by the installed software that may cause security issues in the phone. Such actions include accessing files, Bluetooth connections and internal sensors which are widely used by the PAM software. For example, successfully starting the PAM sensors application required the user to confirm up to five security prompts. Selected phones from other manufactures allow customising the level of such security precautions (e.g. requiring confirmation only during the first use of a functionality). This was taken into consideration for the reassessment for later trials.

As expected, the proposed bed usage sensor was the only device that caused acceptability problems. Most participants decided against testing the sensor in order to maintain their

privacy during the trial. The proposed modified placement of the mat (on the side of the bed) proved to be more acceptable. In all cases however, a certain level of unease regarding monitoring devices in the bedroom was observed.

4.2.4.1 Reassessment of the setup

In light of the experiences gained during the technical trial it was decided to alter some protocols and elements of the PAM system for further tests. The following changes to the sensory system were made before proceeding with a trial involving patients:

- The Nokia 6120 navigator was replaced by Sony Ericsson phones (K550, C510 and W715) which allowed better customisation of security prompts so reducing the nuisance for future users
- Only external GPS would be used due to its higher reliability and lower battery usage. In addition the mobile phone is capable of storing other wearable data when the external GPS unit's battery gets discharged.
- The suggested placement of the bed usage mat would be on the side of the bed so as to reduce the discomfort for the user.

Moreover, the issue of an overwhelming number of devices being carried was addressed. To tackle this issue, a separate trial exploring the possibility of limiting the hardware part of PAM solely to a mobile phone was designed and conducted. The procedures and results are presented in Chapter 5.

4.3 Patient trial

The next stage, following the technical trial, was to test out the technology in the end user scenario. This meant inviting BD sufferers to test the technology and share their views on all aspects of the proposed system as well as to participate in a trial similar to the one

described in the previous section. To facilitate this, a recruitment process was started in the Southampton and Stirling area.

4.3.1 Recruitment and interviews

Initial contact with potential trial participants was made by advertising on a mental health charity website (Solent MIND, www.solentmind.org.uk) and by approaching local self-support groups. Volunteers were invited to email or telephone one of the members from the research team, who then provided an information pack which included an initial consent form (to a home visit by the team) and a request for a letter from the participant's GP confirming that the person's participation was acceptable. During a further period of two weeks the patient was requested to consider the participation, obtain the letter from the GP and to return the consent form. Unfortunately, it was found that most of the ten patients, originally interested in participating, withdrew at this stage of recruitment.

For those who decided to proceed, on receipt of the signed consent form and GP letter, the researchers contacted potential participants by email or telephone and made an appointment for a home visit. During this first visit, which lasted between one and two hours, at least two members of the research team gave a full verbal explanation of the nature of the involvement in PAM and demonstrated all sensors. Afterwards each volunteer was given a further week to consider their involvement, after which, potential participants were contacted again to confirm that they wished to proceed. If this was so then an appointment was made for a second home visit.

At the second home visit, made by three members of the research team the main consent form was signed (to agree to the PAM system being installed). This was followed by an entry interview performed by the researchers from the University of Southampton and evaluation of the acceptable set of PAM sensors to be used for the individual, and then their

installation commenced followed by the user training. Participants had the right to withdraw at any stage during the study and have all of their data removed and deleted.

During the recruitment process three participants agreed to the initial home visit but only one participant proceeded with the full installation as others withdrew before the second visit. The individuals did not disclose their reasons for not participating and no further contact was made following their decision in agreement with the ethical guidance obtained.

4.3.2 Deployment

The sole remaining participant of the trial was a mid-aged female living alone in a terraced house. In accordance with the ethical guidance, no detailed clinical information about the participant was made available to the author. The installation consisted of the described PAM system modified according with the discoveries arising from the technical trial. The participant decided to incorporate all of the available sensors into her environment. As in the case of some technical trial participants, the bed sensor was placed next to the bed rather than under the mattress according to the patient's wish.

Following the installation and user training, the research team performed a number of maintenance visits to troubleshoot the reoccurring drop-out problems of the environmental box (which was placed too far from the data-collecting PC) as well as to provide additional usage instructions to the user.

4.3.3 Results

The main outcomes of the trial were: surveying the acceptability of a PAM system and detecting further user compliance issues that may arise from the system being used by a patient. The high rejection rate among the interviewed patients indicates that the system may

present itself as too obtrusive thus providing justification for the modifications evaluated in the next chapter.

In terms of sensory data, the patient trial produced activity data similar to the sets obtained from the main trial. Since the patient remained euthymic (asymptomatic) throughout the monitoring period, there were no major aberrations from her usual routine. However, the data collected by the wearable node, which depends most on user compliance with a maintenance regime, was far scarcer than from any participant of the technical trial. In one of the intermediate interviews, the patient addressed the issue of not adhering to the routine citing the following reasons:

- Discomfort of carrying extra devices in addition to the mobile phone.
- Forgetfulness regarding charging the sensors, phone or manually starting the monitoring application.
- Lack of familiarity with personal technology in general (not only the PAM system) resulting in underdeveloped user habits.

Figure 4-14 presents a summary of how well the participant adhered to maintain separate elements of the wearable setup. The figure shows the uplink times for the devices during a period of most intensive usage of the wearable setup.

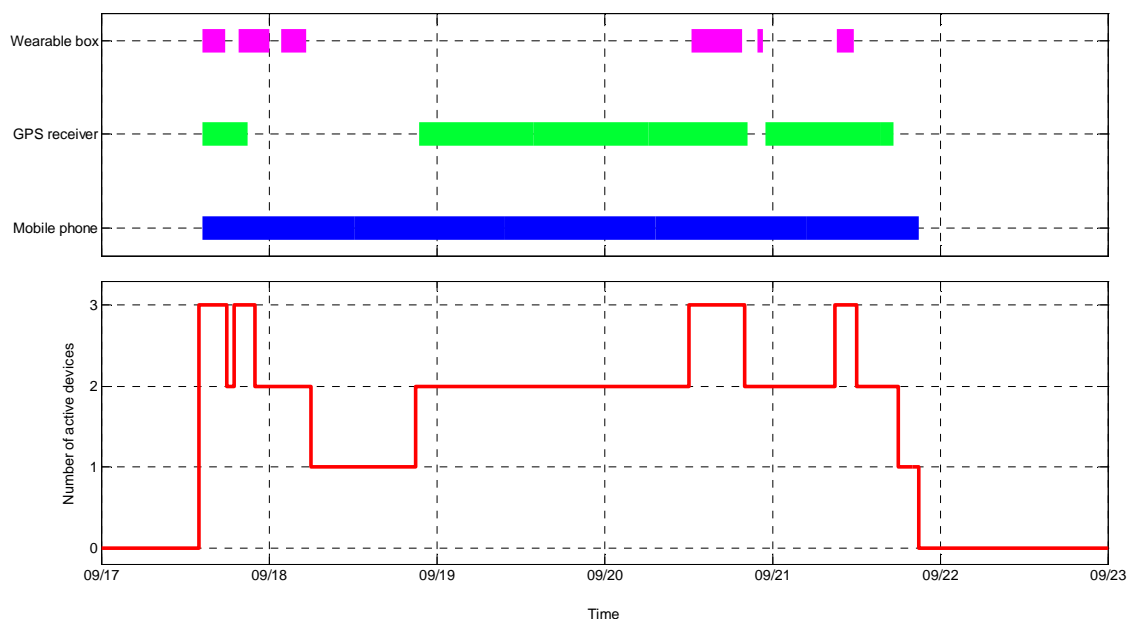

Figure 4-14 Uplink times for elements of the wearable setup

It can be observed that while the phone was on and monitoring, the remaining elements were either switched off or remained out of Bluetooth range during extended periods. This was typically due to the user carrying the phone but not the rest of the setup.

4.4 Summary

Trials of the PAM prototype system described in the previous chapter were presented in this chapter. The commenced trials included a non-patient technical trial and were followed by an attempt to include BD sufferers in assessing the technology.

The technical trial resulted in data which could be fed into a behavioural pattern detection algorithm that showed coherence with user-reported habits and activity. Concurrently, usage and adherence issues were identified mainly in the wearable part of the setup. The trial showed that additional elements that need to be carried by the user may well be not used. The problem was particularly apparent in the patient trial which resulted in similar conclusions.

The recruitment process for the patient trial required central ethical approval which was granted. The ethical procedures imposed several restrictions with regard to prospective system testers including the requirement for volunteers to be in the euthymic stage of the disorder. The recruitment process resulted in a sole participant who tested the system during three month period. As stated above, the adherence to usage guidelines in terms of wearable sensors was poor. In practice, the phone was carried and used more often than other elements of the wearable setup. This observation along with feedback from the psychiatric community was the basis for investigations described in the next chapter.

5 Phone-based PAM

This chapter describes an investigation into the concept of personalised ambient monitoring based solely on data that is possible to obtain from a mobile phone. The section discusses the premise of such a setup and presents the results of trials performed independently from the main PAM trial described in previous chapters. Methods of analysis and interpretation of the collected data are also enclosed.

5.1 Premise

The development concept and prototype of PAM was presented at several meetings and conferences [66,80,107-109]. Those presentations raised interest with the psychiatric and general scientific community and resulted in expert feedback, which, along with user experiences arising from the technical trial of the prototype, led to the reassessment of the possible PAM scheme. An investigation was conducted into researching a behaviour monitoring system basing on a mobile phone only without the use of additional devices.

5.1.1 Initial feedback on PAM

The work related to development and testing of PAM described in previous chapters was presented at various meetings including Med-e-Tel 2009 and the IEEE Engineering in Medicine and Biology Conference (EMBC) 2010 [80,108]. Some of the experts present at those events approached the author with comments, most of which included one recurring theme. The concern was that the system as proposed may be too excessive for the majority of patients to use comfortably, causing compliance problems and data loss as a result. The number of devices that must be carried and incorporated into the home requires that the user

needs to comply with a variety of basic maintenance routines (e.g. charging batteries) which may pose an issue considering the specificity of the target group of users. These comments resonated with the experiences from the attempted trials on BD patients as low adherence to guidelines for carrying wearable sensors was one of the main issues.

5.1.2 The concept of phone-based PAM

This received feedback led to a consideration as to whether the system could be reduced in size in order to improve usability without suffering a total loss of functionality. The obtrusiveness of the system could be reduced by removing unfamiliar and additional elements to the user's clothing and environment.

Revising the original setup it was assumed that a mobile phone is the element that is most likely to be kept and would not cause compliance issues with the user, since these devices are in everyday use and are commonly carried everywhere. As previously described mobile phones also provide location services using a built-in GPS receiver (although it escalates the battery usage) whilst most come equipped with a Bluetooth communications link enabling them to interact with other devices. These attributes provide a means of devising a reduced self-standing monitoring system without the need for additional sensors. Therefore an investigation into the value of acquired geospatial and social data obtained from a mobile phone carried by a participant was conducted.

5.2 Phone sensors

There are a number of data inputs, relevant from a behavioural point of view, which can be harvested from a standard mobile phone, depending on make and model of the device. Usually, the sensory inputs are provided to enhance native functions of the firmware, for example a light detector that enables the automatic control of the brightness of the display.

The investigations presented in this chapter focus on two particular types of data possible to retrieve from most devices. Those are location and Bluetooth encounters information.

5.2.1 Positioning

As described in Chapter 3, GPS technology is currently the most common way to obtain geospatial position. Many mobile phones also provide location services using a built-in GPS receiver and most come equipped with a Bluetooth communications link enabling them to connect to a range of external GPS receivers.

The main disadvantage of GPS localization is the poor visibility of satellite signals when indoors or in other locations with an obstructed view of the sky (e.g. dense forests). This can, however, be rectified by the use of GSM cell information. In order to perform its basic functionality, every phone is connected to the GSM network which is divided into cells (hence the term cellular phone) located around a base station. The size of these cells varies from a radius of tens of kilometres in non-urbanised areas to tens of meters in dense city environments [85]. If the location of the base station to which the mobile phone is currently connected is known then this information along with the signal strength can be used to obtain its approximate location. Considering the frequency of the radio signal (usually of 900MHz) combined with relative closeness of a transmitter, the penetration of buildings and structures is much deeper than GPS (whose base frequency is approx. 1.5 GHz). This can be used to obtain positional information where GPS localization is unavailable [110].

5.2.2 Bluetooth encounters

Bluetooth technology is being incorporated into an increasing number of devices. It is estimated that globally there will be more than 2.4billion Bluetooth enabled devices by the year 2013 (with at least half of such devices expected to be phones and PDA's) [111].

Mobile phones equipped with Bluetooth connectivity have mechanisms allowing them to discover all visible Bluetooth devices in range (up to 100m for Bluetooth class 1 devices). Information about the number and type of such devices provides a means of inferring much about the users' context and their surroundings. For example, discovery of another Bluetooth enabled phone indicates the presence of another individual carrying a phone who can possibly then be identified. The general scheme is illustrated in Figure 5-1.

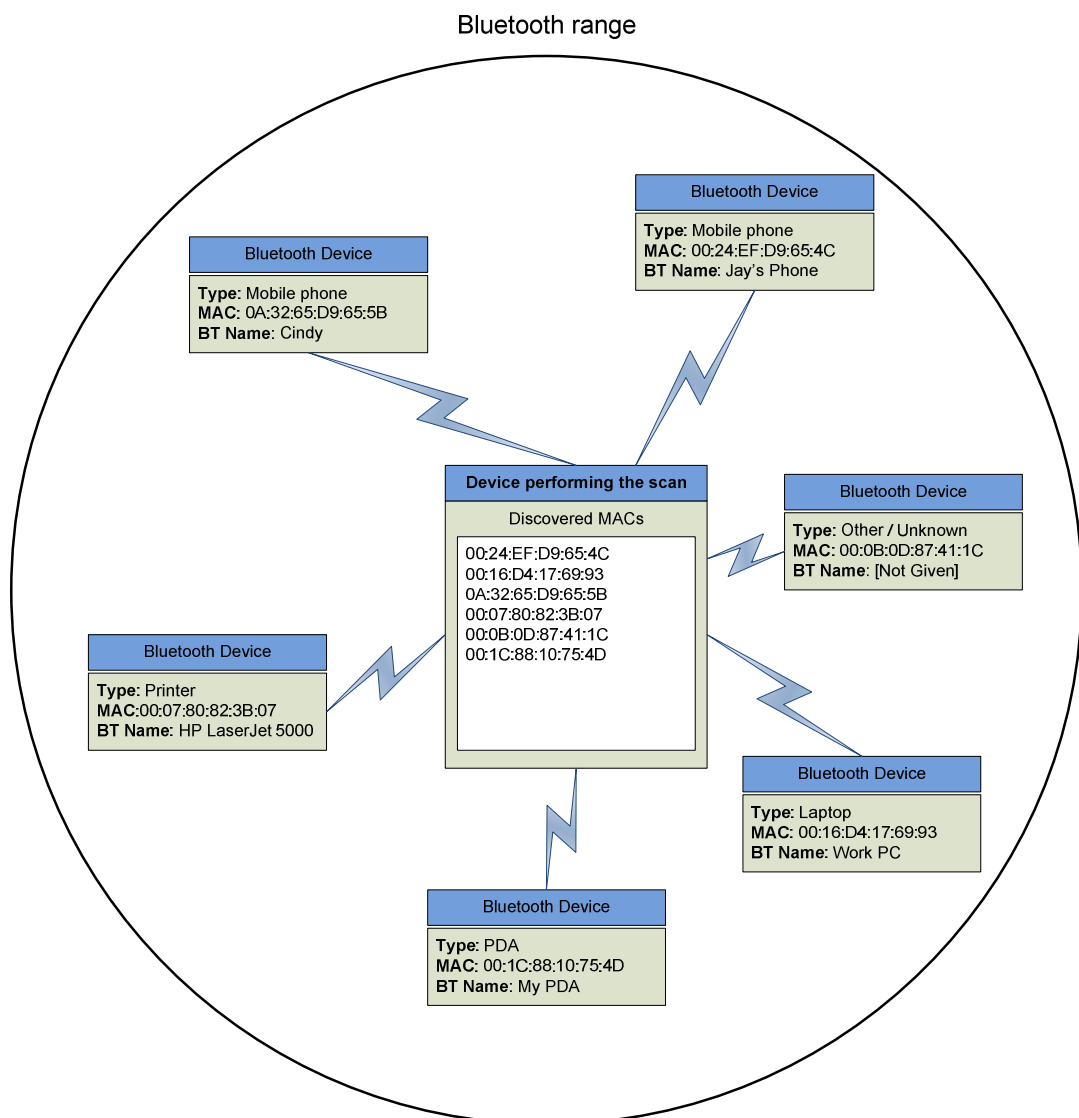

Figure 5-1 Example of a possible Bluetooth context

Techniques based on Bluetooth encounters are already utilized to infer friendship networks [112,113], provide location-related information [114] or even provide common ground for interaction between two people in Bluetooth proximity based on their pre-shared profiles [115]. The promising results of these investigations led to the idea that performing Bluetooth scans can provide valuable information about social interactions, an area strongly affected during the course of most behavioural disorders [53].

5.3 Trial

A technical trial aimed at devising a methodology of extracting information regarding social behaviour from the data that is possible to obtain from a mobile phone was designed and performed following the technical trial of the main set of sensors described in the previous chapters. The experimental hardware and software setup consisted of one (or two) wearable elements of the setup described in Chapter 3 namely the phone and optionally an external GPS receiver. Modifications, mainly in the software layer, made before the study are described in the following sections.

The main objective of the trial was to collect geospatial and Bluetooth encounter data from a number of participants. It was expected that simplification of the hardware setup would improve user compliance and data coverage as the system would be more likely to be used. The collected information was used to devise means of analysis and derive about the basic behaviour patterns of the monitored individual.

5.3.1 Setup

The main aim of the trial was to acquire and process data solely from a mobile phone. The hardware consisted of either a Sony Ericsson G502 or Nokia 6120. The latter contains a built-in GPS receiver although both of the devices could be paired with a Bluetooth enabled

GPS receiver (BlueNext BN-906GR). The advantage of such an arrangement, over the use of an in-built GPS receiver, was the higher reliability of a quality external receiver in comparison with the internal one available in the phone. Such an off-the-shelf GPS device packaged as a convenient keychain did not increase the obtrusiveness of the setup nor compromised the main requirement of the trial. What is more, it was found that the combined average battery life of a phone and an external receiver is higher than that of a phone with an internal GPS receiver.

The phone's software constituted of a single Java application based on the PAM sensors application described in Chapter 3. The modifications included:

- Removing the capability to connect to other wearable elements not applicable in this scenario.
- Enabling the collection of cell information (identification number of the currently used base station).
- The memory leak which caused the exclusion of Bluetooth encounters monitor in the trials described in the previous chapter was fixed.
- The option of utilising the phone's internal GPS receiver was reintroduced to facilitate obtaining geospatial data without additional devices.
- Simpler CSV data storage format was used for ease of further processing.

No user input questionnaires or automated data transfer applications were used in order to simplify the protocol. Data was collected off the phones after the trial with the position data recorded as sets of four values: latitude, longitude, speed and satellite count, with the data sampled and stored every four seconds. Current cell ID was stored in conjunction with every GPS reading in order to simplify the synchronisation of the two types of readings. Bluetooth encounter scans were performed every 10 minutes and stored as a set of unique

MAC addresses of the discovered devices. The frequency of the scans was selected as a compromise between minimising the battery usage necessary to perform scans whilst ensuring that a device present in the surrounding area for a significant amount of time would be detected.

5.3.2 Participants and ethical approval

Since the objective was to test the technology and devise tools for data analysis the subject group did not include patients suffering from the investigated disorder. Rather, the control experiment consisted of two male and two female subjects aged between 20 and 29, who have no history of BD, although one of the female subjects has been diagnosed with depression in the past. The experiment lasted for a period of time between three and eight weeks in different locations in the UK, Poland, Sweden and Uganda (as participants travelled between those countries). During the trial, subjects were asked to keep both the trial phone and the GPS receiver (if not using the built-in capability) with them at all times, although they could disable or terminate the monitoring application at any time.

Since there were neither significant data inputs nor devices added compared to the main PAM prototype (as the aim was to reduce the extensiveness of sensor network), the experiment was performed under the ethical approval obtained for testing the complete system. The participants were given the same information and consent forms as in the technical trial described in Chapter 4 with the description of unused devices and techniques removed.

5.4 Results and analysis

The trials performed between February and August of 2010 resulted in a database consisting of over 2 million separate GPS readings (combined with cell network

information) and the results from nearly 15 thousand scans for Bluetooth encounters. The users complied with the usage instructions, which resulted in good coverage of data in the temporal domain. This provided a solid base for investigating the extraction of patterns from the acquired data. Participants were interviewed immediately after the trial in order to provide information that could be used to validate results derived from the recorded data. To minimise the error caused by the recollection process, each user was asked before the trial to take note of the places visited when being under monitoring. However, to minimise the inconvenience, they were not asked to keep a strict diary of visited locations.

To make it easier to generalize the methodology between datasets, longer lasting trials were divided into four week segments (unless the trial was shorter than this period). The datasets are identified by two numbers: the first one indicating the participant and second indicating a particular 4-week dataset (e.g. dataset 3.2 indicates second dataset of Participant 3).

5.4.1 GPS tracks analysis

Literature shows that the most significant information that is possible to obtain from even sparse GPS tracks is the user's meaningful locations [116,117]. The key is to transform physical coordinates obtained by positioning technology into a domain where places are described in terms of their meaning for the user (for example *home*, *workplace* etc.). Such places can be then classified and their importance derived.

The data collected in the experiment was analysed in order to discover such locations. Figure 5-2 presents a map containing one of the GPS datasets for Participant 2. All figures found in this chapter are generated from the same dataset 2.1 (unless stated otherwise). Figures and analysis results of other participants' data (i.e. datasets 1.1; 1.2; 2.1; 2.2; 3.1; 3.2 and 4.1) can be found in the appendix.

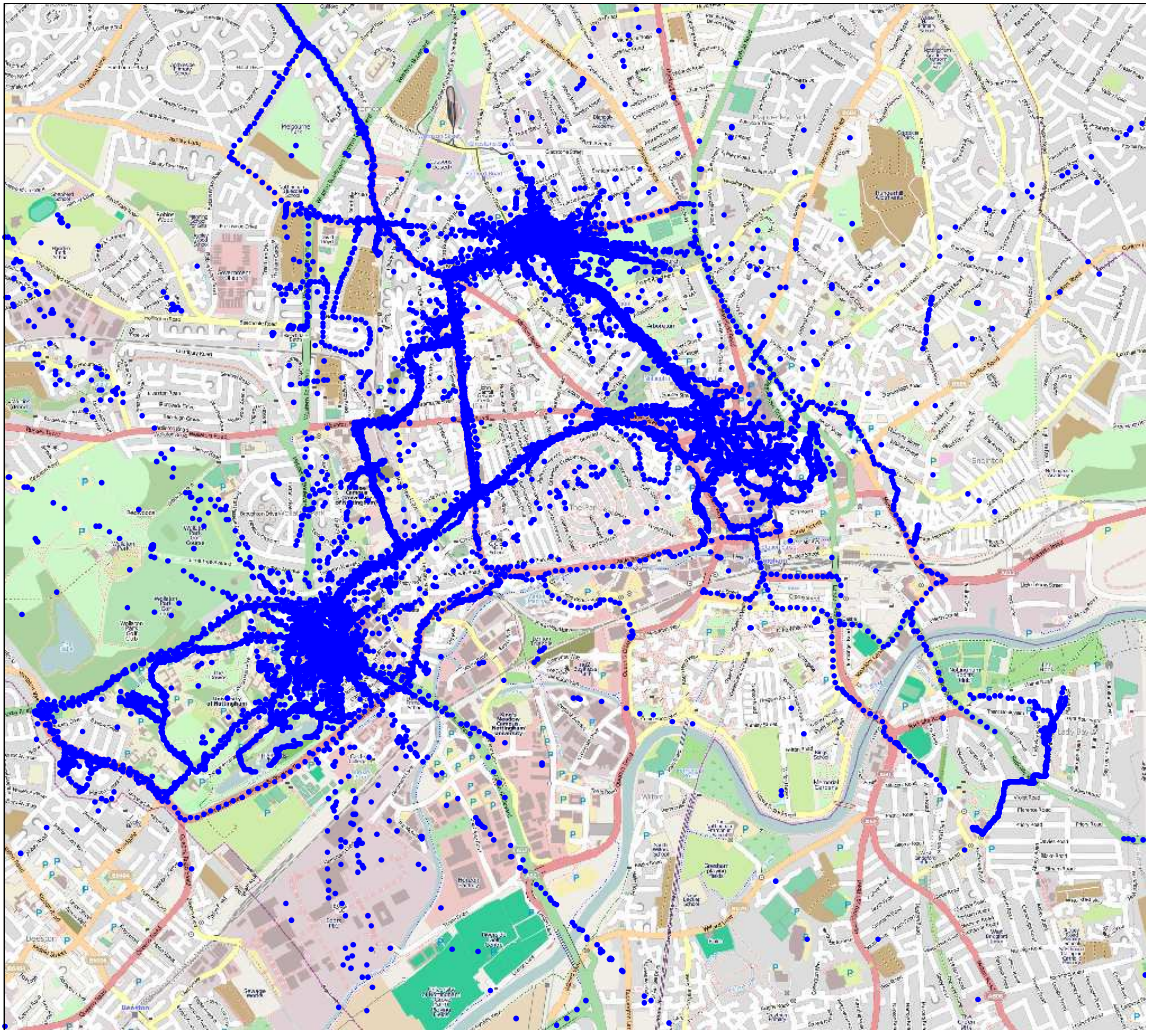

Figure 5-2 Geospatial tracks from dataset 2.1

It can be observed that the data is noisy as points are scattered uniformly throughout the plane. Moreover, linear tracks bearing no relation to actual location (most likely resulting from Kalman filtering used internally in the receiver) can also be observed. Nevertheless, clusters of points are clearly visible with narrow traces along the roads leading between them.

5.4.1.1 Pre-processing points

Before significant locations can be discovered it is necessary to process the collected geospatial points in order to reduce noise and so achieve better separation between the clusters which correspond to these locations.

Pre-clustering processing of the data consisted of removing all readings based on three or fewer satellites, which includes those producing the linear features in the bottom left quadrant of the Figure 5-2. Since the main aim of the clustering process was to detect significant locations rather than map the journeys between them, another pre-clustering step was to eliminate points where the recorded speed (provided by the GPS receiver using its internal calculations) suggested the subject was moving. Taking this into consideration a dataset was produced consisting of points gathered when the speed was less than 1km/h. Figure 5-3 shows the data from Figure 5-2 distinguishing between points with low satellite visibility and those where speed indicates movement, whereas Figure 5-4 shows the resulting dataset with these points removed, so illustrating more separate clusters of readings.

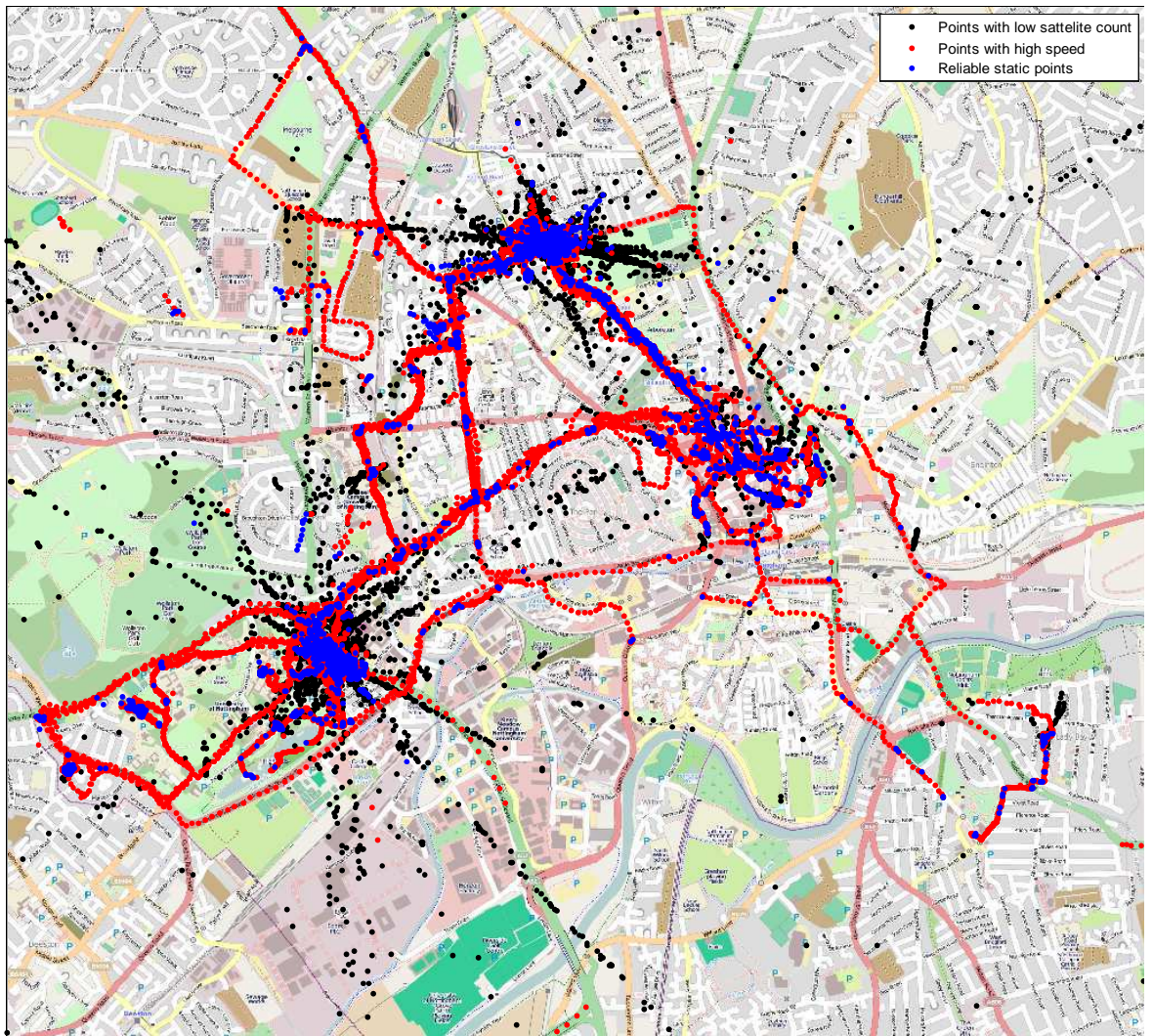

Figure 5-3 GPS tracks from dataset 2.1 segregated with regard to satellite count and speed

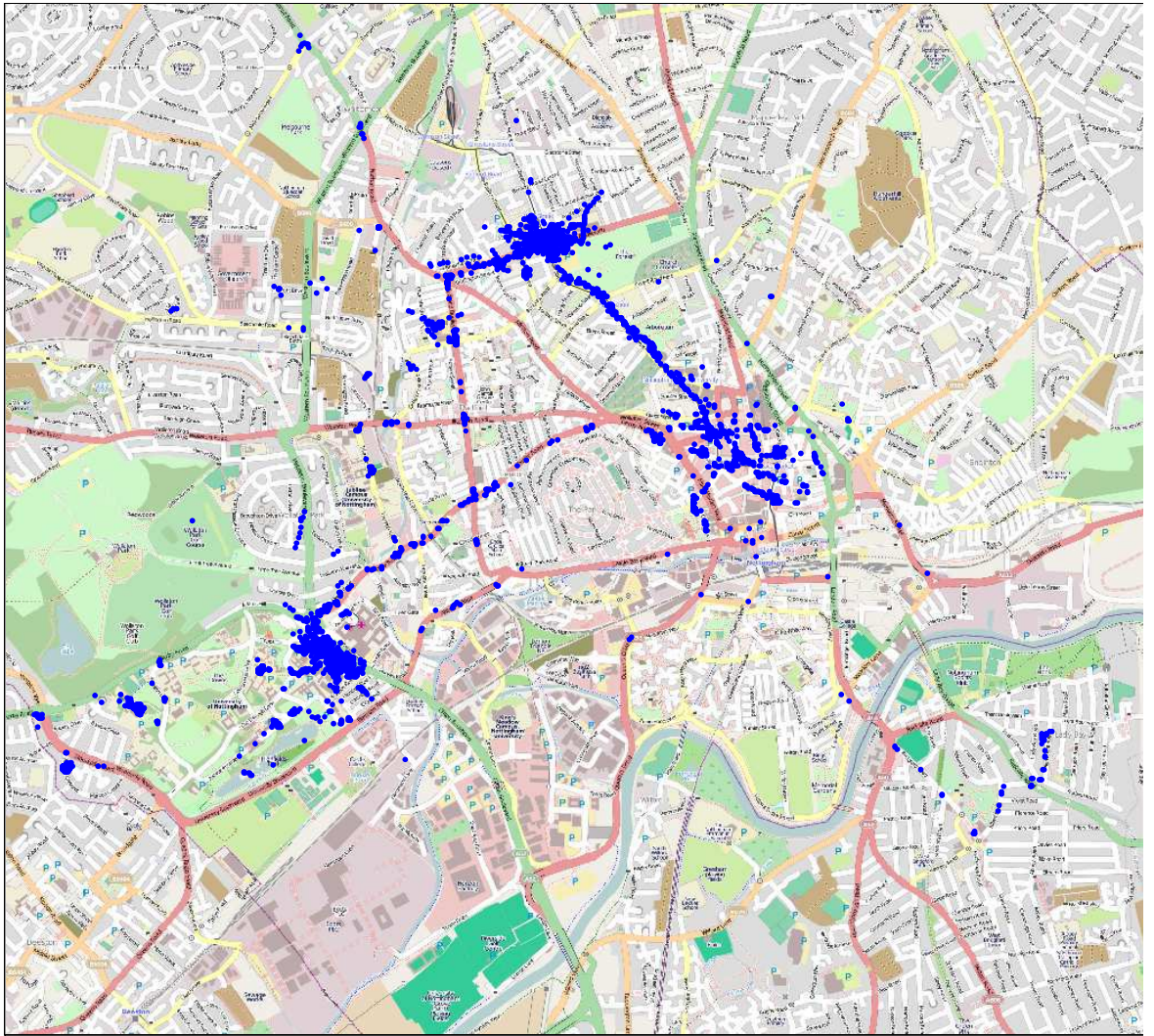

Figure 5-4 Processed dataset 2.1

5.4.1.2 Clustering

There are numerous clustering algorithms that can be utilised to solve the problem of clustering such data. These include Bayesian probabilistic algorithms and simple k-means to more complex methods [118].

However, the literature suggests that the technique that is applied the most is Density-Based Partitioning. Algorithms from this group try to discover dense connected components of data, which are flexible in terms of their shape. Density-based connectivity is used in the

algorithms DBSCAN, OPTICS, DBCLASD, while the algorithm DENCLUE exploits space density functions. These algorithms are less sensitive to outliers and can discover clusters of irregular shapes. They usually work with low-dimensional data of numerical attributes, known as spatial data [118]. Such qualities render them as a good tool to deal with the geospatial data collected here. The first of the listed algorithms: Density-Based Algorithm for Discovering Clusters in Large Spatial Databases with Noise (DBSCAN) has already demonstrated its effectiveness in clustering geospatial records [117,119,120].

DBSCAN was developed at the University of Munich in 1996 and has since become one of the most commonly used algorithms for clustering large data sets. The algorithm targets low-dimensional spatial data with only two input parameters ϵ and MinPts which are used to define the following constructs:

1. An ϵ -neighbourhood of a point $X = [x_1, \dots, x_n]$ defined as a collection of points Y for which $d(X, Y) < \epsilon$, where d is the Euclidean distance between the points.
2. A core object is a point with a ϵ neighbourhood consisting of more than MinPts points.
3. Point $Y = [y_1, \dots, y_n]$ is density-reachable from a core object X when a finite sequence of core objects between X and Y exists such that each belongs to an ϵ neighbourhood of its predecessor.
4. Two points X, Y are density-connected when the two are density-reachable from a common core object.

So defined density-connectivity is a symmetric relation and all the points reachable from core objects can be factorized into maximal connected components serving as clusters. The points that are not connected to any core point are declared to be outliers (they are not covered by any cluster). The non-core points inside a cluster represent its boundary. Finally, core objects are internal points [121].

The values of parameters ϵ and MinPts should be selected with respect to the data features. The former should relate to the data resolution (how close the points can be from each other) whereas the latter is crucial and defines how dense the sought clusters should be.

There are several reasons for favouring this method. Firstly, a small set of input parameters makes it easy to generalize the methodology. Secondly, the method does not aim to cluster all the points in the input database meaning that a substantial subset may emerge un-clustered and so can be considered as “noise”. This is a crucial feature as many recorded points will clearly not belong to a significant cluster (i.e. a meaningful location). For example, there may be readings taken during the transition between locations that are better left un-clustered.

In the processing of the trials results the ϵ value was set at a constant value of 5 times the resolution of a GPS reading which is 0.0005 degrees in coordinate space. This corresponds to an area of approximately 30 by 50 meters in Europe where the vast majority of readings were taken. Varying the value of MinPts parameter was the factor that influenced the number and significance of discovered locations. The process is described below.

5.4.1.3 Density and clusters

Considering the temporal features of GPS readings, the MinPts parameter can be related to the total time spent by the subject in a particular location. In the presented approach data was first clustered with a parameter value of 5000. Taking into account the sampling period (one point is taken every 4s.), this corresponds to approximately 5.5 hours worth of records within a cluster throughout a particular 4-week dataset, although the actual time may be greater due to the fact that points with poor satellite coverage (mostly from indoor monitoring) were disregarded (see pre-processing). Figure 5-5 shows results of such clustering performed on the data presented in the previous figures.

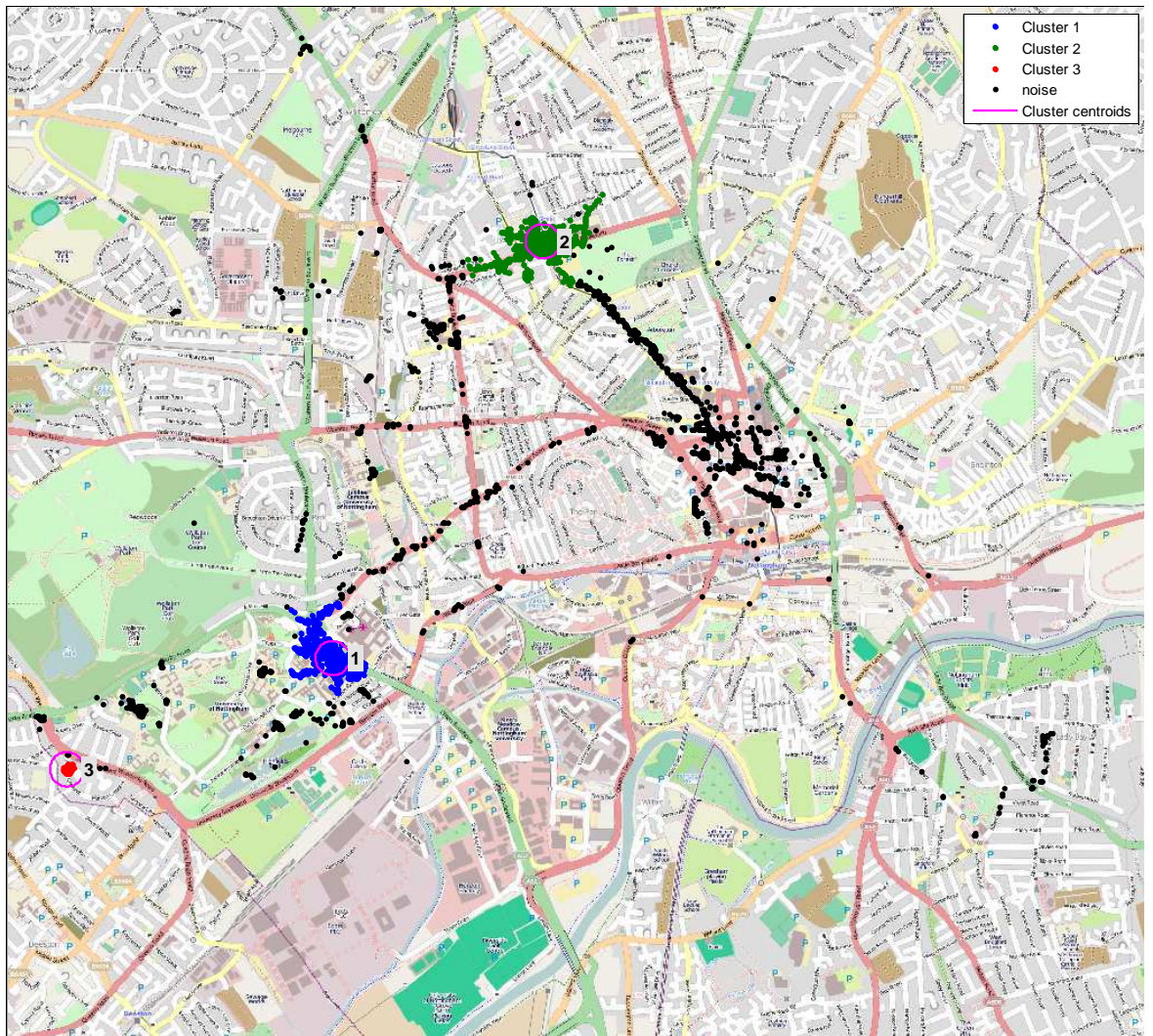

Figure 5-5 Dataset 2.1 clustered with MinPts set to 5000 (high density clustering)

Here, a significant subset of the points was classified as noise. This indicates that the spatial density is not high enough to constitute a cluster with the specified parameter. However, such noise may still carry information about less frequently visited places. Such a possibility was explored by taking points classified in the previous step as noise and applying a less rigorous clustering via use of a significantly lower MinPts value of 500 (Figure 5-6). This procedure was repeated also for a MinPts value of 150 (Figure 5-7).

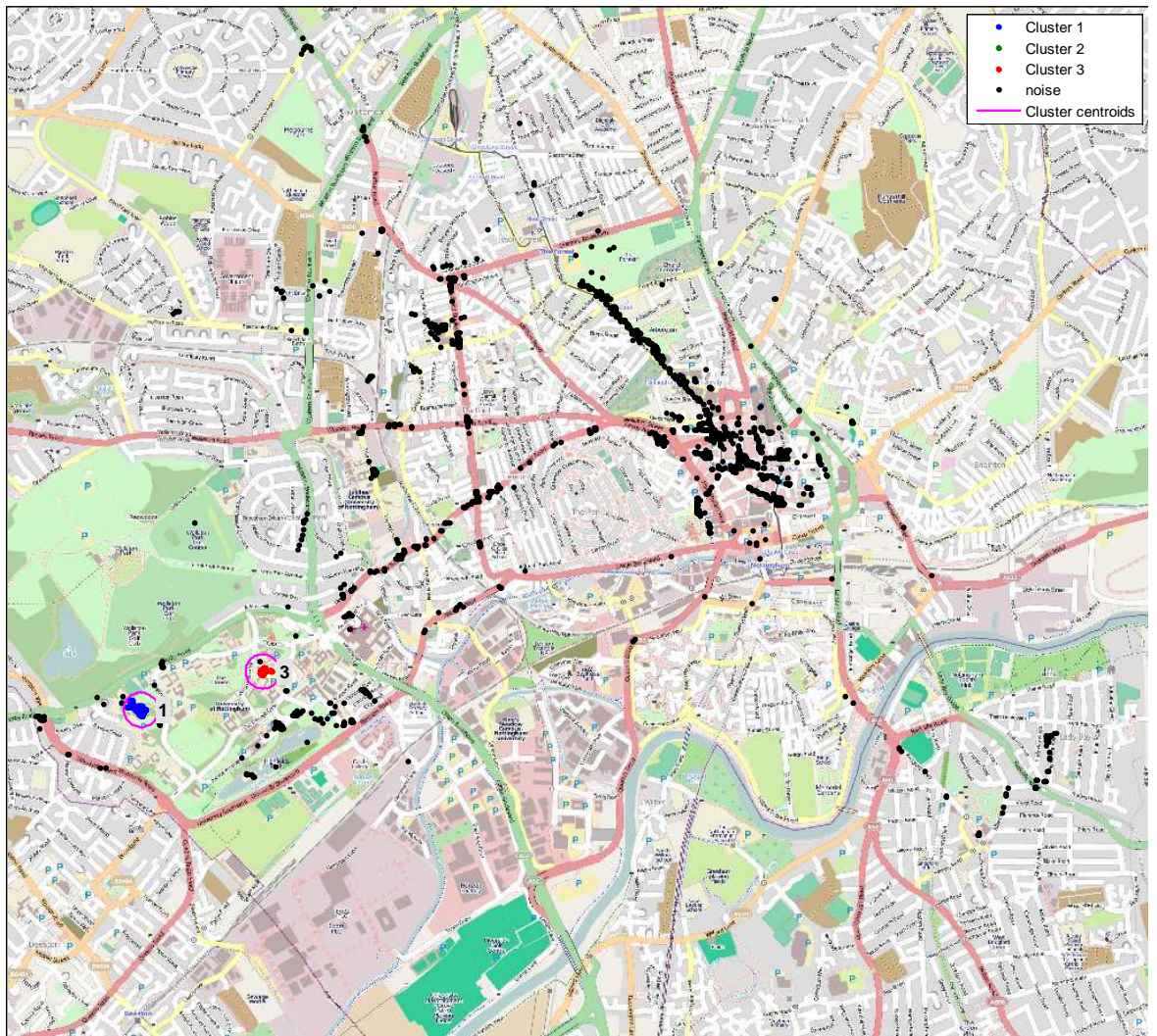

Figure 5-6 Remainder of dataset 2.1 clustered with MinPts set to 500 (medium density clustering). Note: Cluster 2 is outside the plotted area

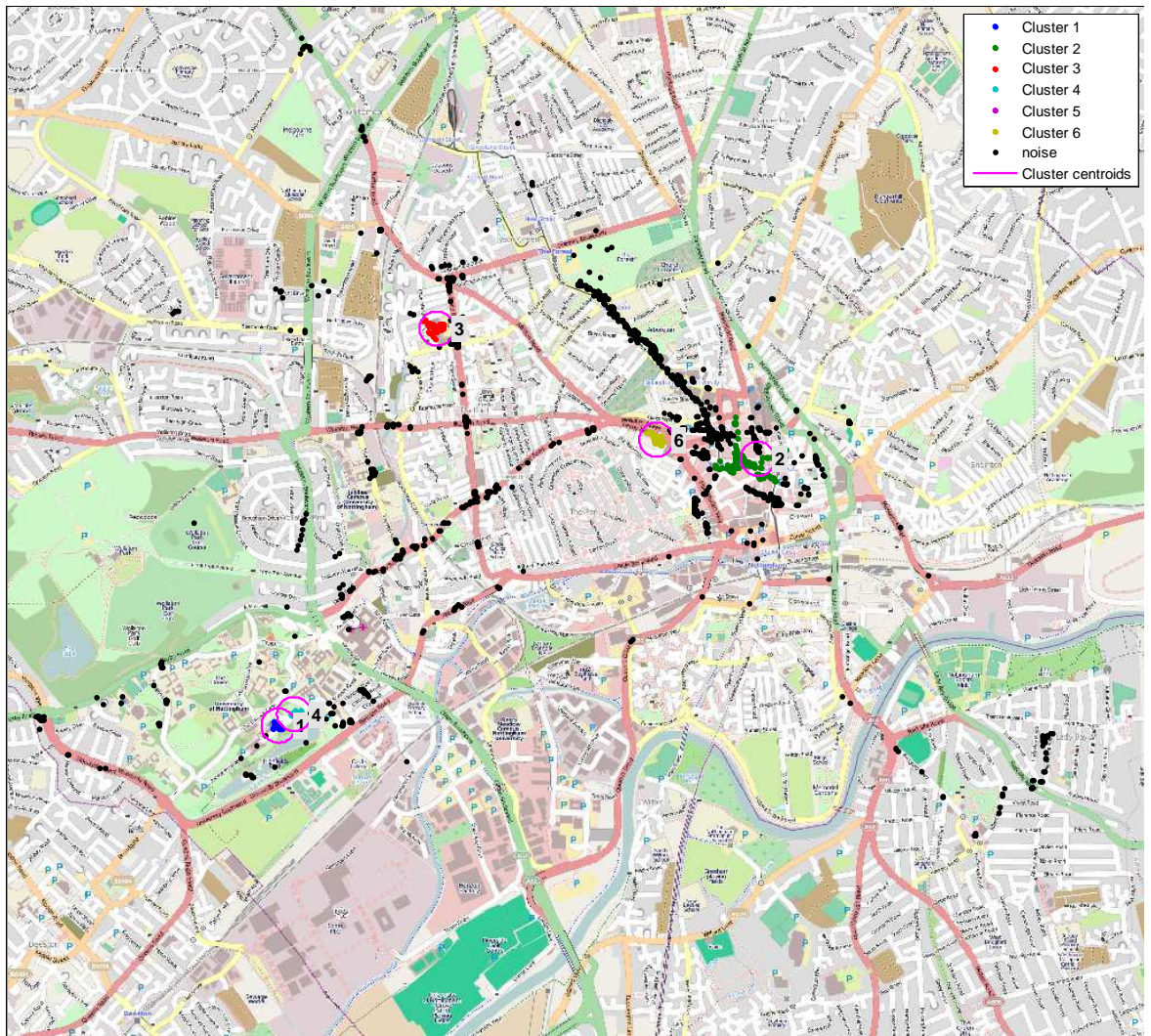

Figure 5-7 Further remainder of dataset 2.1 clustered with MinPts set to 150 (low density clustering). Note: Cluster 5 is outside of the plotted area

5.4.1.4 Significant locations

In order to verify the clusters, subjects were shown the maps as in figures 5.2-5.7 generated on their data and asked to identify places where clusters were found. In all cases, users were able to successfully identify discovered clusters as meaningful locations. Table 5-1 presents the results of cluster discovery and identification for one of the subjects. In general, clustering performed with greater values of MinPts identified frequently visited places with a large average occupation time such as home, workplace or gym. Lower values

of MinPts enabled the discovery of less frequently visited places (e.g. one-off visits) as well as places that were visited frequently but for short periods of time (e.g. regular bus stops). The reports cohere with a timeline showing the presence in each cluster generated from reading timestamps as shown in Figure 5-8. Gaps in the plot represent times when the monitoring was essentially inactive, that is, when it had been turned off or no satellites were in view.

Table 5-1 Example of cluster verification for dataset 1.1

Cluster number	MinPts parameter	Description given by participant		
		Place	Times visited	Avg. duration
1	5000 (high)	Workplace	Constantly	Hours
2	5000 (high)	Home	Constantly	Hours
3	500 (med)	Sports centre (gym)	Often	1 hour
4	500 (high)	Friend's house (1)	Several	2-3 hours
5	150 (low)	Bus stop	Several	< 15 minutes
6	150 (low)	City Centre	Several	1 hour
7	150 (low)	Sunday market	Once	1 hour
8	150 (low)	Bus stop	Once	< 15 minutes
9	500 (med)	Campus pub/ cafeteria	Several	1 hour
10	150 (low)	Bus stop	Twice	< 15 minutes
11	150 (low)	Bus stop	Once	< 15 minutes

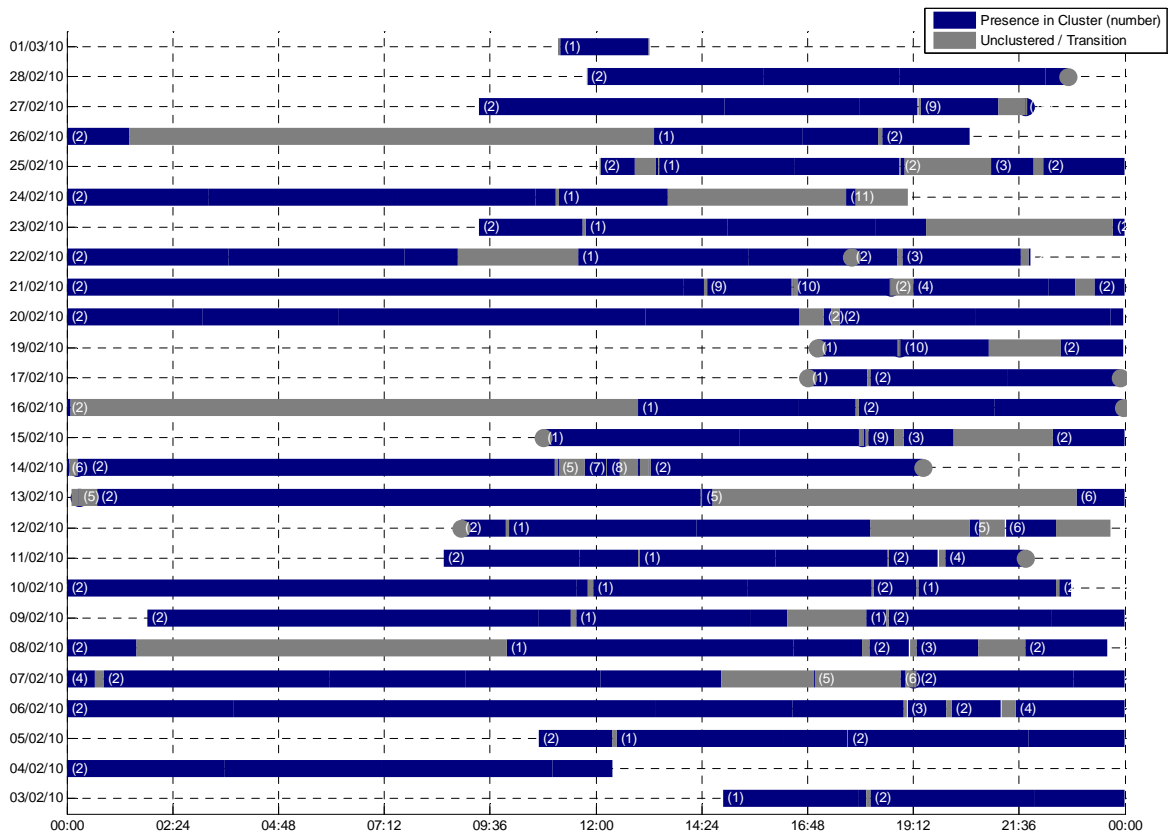

Figure 5-8 Presence in clusters over time. Each row corresponds to a day in the monitored period. Cluster numbers correspond to those presented in Table 5-1.

5.4.2 Inclusion of cell information

While performing the pre-processing it became apparent that removing unreliable points with low satellite visibility resulted in rejecting an average of 30% of readings in all datasets (up to 45% when using the less reliable Nokia phone with an internal GPS receiver). Moreover, interviews with the participants revealed that although most of the frequented locations were discovered, some visits, mostly one-off visits to indoor places, failed to be identified. Investigations have been conducted towards rectifying this loss using cell base station ID information, which was stored in conjunction with every GPS reading taken.

It is theoretically possible to resolve base cell ID to their position. However, this requires prior knowledge about the location of cells owned by the particular GSM network operator.

Although there is a database provided by Ofcom containing such information for the UK and [122], the data in the described trial covered numerous location in several countries and most open-access databases (including ofcom) containing cell locations are scarce and incomplete for these places [123].

In light of this fact the use of GSM network information was put to use not as a self-sufficient method of localisation but rather as information complementing the GPS readings where satellite visibility was particularly low (mostly indoors). The logic was then used to improve GPS information and appraise its influence on the results generated using the methodology described above.

5.4.2.1 Method

Most commonly, the loss of GPS link is the result of the user entering a large structure such as a high rise building. The thick concrete walls and other type of obstructions cause the GPS receiver to lose the line of sight and so provide unreliable data. In many cases however the mobile phone remains connected to the base station.

The main assumption of the proposed method is that if the GPS signal has lost its strength but the ID of the currently connected base station stays the same it can be assumed that the user has remained in the same area but the view of GPS satellites has been obstructed. Therefore, all subsequent readings where there is no GPS link but the same cell ID is recorded are to be treated as readings from the last reliable GPS position recorded. The proposed algorithm replaces all following readings with the last established position until a reading with a different cell ID or a re-established GPS fix is recorded. Figure 5-9 illustrates the process.

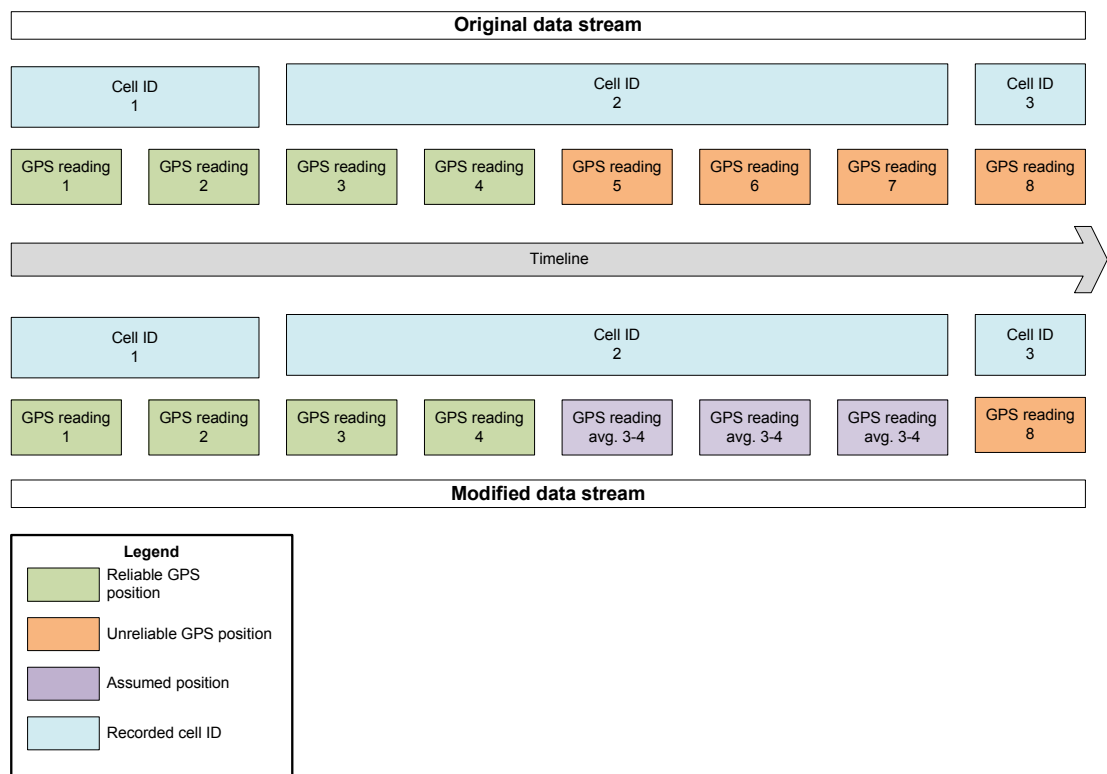

Figure 5-9 Complementing GPS readings with GSM information.

5.4.2.2 Effect on the results

The method of complementing GPS data via the use of cell information was validated by re-processing and re-clustering of the datasets amended according to the devised algorithm. To achieve the comparability of the results, the process was performed in the same manner as with unmodified GPS readings. Data was clustered on three levels of MinPts density: 5000, 500, 150 and compared with the corresponding results from original datasets.

In all cases new clusters were discovered. Moreover, some clusters identified with the standard routine exhibited a higher density in the amended method and as expected, this applied mostly to indoor locations with a low frequency of visits, where the density of reliable readings outside those places was not high enough to be detected using solely GPS information.

The application of the method using low values of MinPts, however, resulted in emergence of clusters that failed to be recognised by the participants (i.e. false positive). False positives were not observed within high and medium density clusters in all datasets. This suggests that such a methodology of enhancing GPS readings should be used only for high to medium density clustering.

The overall effect of including GSM network information in the process of clustering is illustrated in Table 5-2 created for the dataset 1.1 which is characterised by the highest difference in the number of discovered clusters detected using both approaches. Numbers in brackets show the number of clusters successfully identified by the users. Remaining dataset information can be found in the appendix.

Table 5-2 Clusters detected in dataset 1.1 with and without the use of GSM information.

	Using GPS	Using GPS and Cell ID
Number of geospatial points	457014	-
Number of points after pre-processing	98876	178222
High density clusters (successfully identified)	2(2)	2(2)
Number of med. density clusters (successfully identified)	3(3)	5(5)
Number of low density clusters (successfully identified)	6(6)	11(6)
Total clusters	11	18
Successfully identified clusters	11	13
False positives	0	5

5.4.3 Bluetooth encounters

The phones performed a total of 14500 Bluetooth scans during the trial. The datasets were divided into 4 week long parts to match the division of positional data. The number of performed scans throughout such datasets varied from 800 to more than 2000 as the implementation of the scanning facility is device-dependent. One of the devices (Nokia) continued scanning until all detectable devices were discovered resulting in long-lasting scans whereas the other (Sony Ericsson) employed a fixed time span for each single scan.

5.4.3.1 Processing

Each scan produced a timestamp and a set of hexadecimal MAC addresses of the devices discovered in range. This allowed the identification of times when the number of encountered devices was particularly high, which would indicate a crowded area, such as a bus or a busy city centre.

In order to extract more useful information from the datasets, they were transformed from a temporal organisation to a MAC-oriented one. This resulted in a table of MAC addresses (encountered Bluetooth devices) with assigned dates when such encounters took place. This gave insight into the repeatability of such encounters. The further step was to categorise those devices depending on the frequency of encounters. Those categories were: 'single' (1 encounter in a dataset), 'occasional' (between 1 and 10), 'frequent' (between 10 and 40) and regular (40 and more).

5.4.3.2 Results overview

The average number of Bluetooth encounters per each scan throughout the datasets was just below two. As stated before, the setup based around the Nokia exhibited longer scan times, resulting in more discovered encounters. This became apparent in datasets where one

of the scans performed by a Nokia revealed 169 encountered devices during a scan lasting for more than 30 minutes. The scans performed using Sony Ericson did not show such extreme values. Nevertheless, single scans with the number of discovered devices reaching 30 encounters were also observed in crowded places.

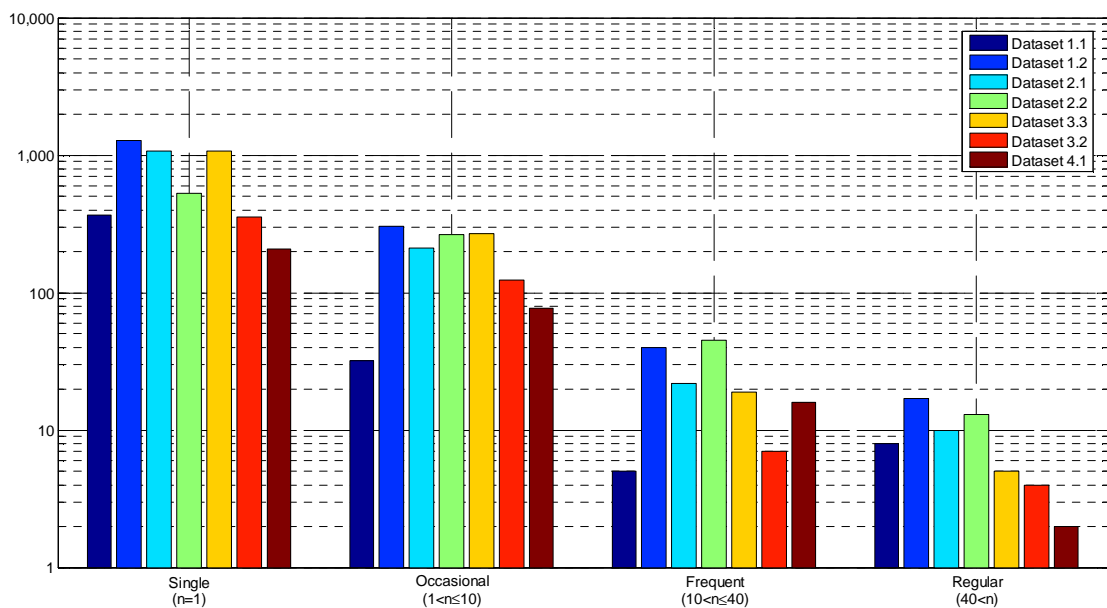

Figure 5-10 Number of discovered devices by category

In all of the datasets the majority of discovered devices were one-off encounters with a small but significant subset appearing more than once (Figure 5-10). An attempt was made to identify the most frequently occurring devices although this procedure was difficult as it required surveying frequented places and discovering the devices that the discovered MAC addresses belonged to. The example of such identification of ten most frequent encounters in one of the datasets is shown in Table 5-3.

To further the knowledge about the discovered devices the scan results were matched with meaningful locations found during the analysis of positional data. Encounter times were matched with the presence in the discovered clusters. The first discovery was that scans that

resulted in the most encounters in the vast majority of cases were usually performed either during transition times or during the participant’s presence in public areas such as city centres or restaurants. Such contexts, in fact, suggest a crowded space with numerous people equipped with Bluetooth technology.

As expected, some of the devices were encountered only in a particular location, such as a Bluetooth enabled home computer or a mobile phone of a work colleague. Others were encountered in more than one location, which was an indicator of social interaction as those devices were identified as mobile phones belonging to friends or spouses. An example of such inference is shown in Table 5-3.

Table 5-3 Identification of most frequently encountered devices for Dataset 1.2

Device MAC	Number of encounters	Locations (clusters) of the encounter	Identification
002298F62929	715	Home and other social (friend’s house, restaurants and other)	Partner’s phone
0016B8A8EBCD	566	Home	Second mobile
001E377F9510	523	Workplace, Home	Work laptop
00197EDF162D	463	Home	Unidentified
000A3A815024	392	Workplace	Laboratory PC
001A897E13E9	360	Home	Unidentified
0026CC64A65D	328	Workplace	Colleague’s phone
0022FDA6FADC	192	Friend’s house, Work, Home, City centre	Friend’s phone
0022A9365CEA	148	Home	Unidentified

In the future implementations, the process of initial identification of the devices could be facilitated by the user who could identify the custom Bluetooth names during a setup procedure of the system.

5.4.4 Change detection

As previously stated, some of the acquired datasets covered up to 8 weeks. This provided a good frame of reference for appraising whether changing patterns of behaviour are reflected in the results obtained with the devised methodology. Maintaining the division into four-week-long datasets, the participants whose data constituted of at least two datasets, were asked to point to any changes to their lifestyle, which was then used to validate the obtained analytical results for the period of monitoring.

5.4.4.1 Participants' reports

Participant 1, a single female, described the first month (dataset 1.1) as average and representative of her usual lifestyle. The second period (dataset 1.2) was characterised by a home refurbishing project, causing her to work from home. Less social interactions occurred during this period.

Participant 2, a male living with his partner, described the time covered by dataset 2.1 as a busy period spent preparing a work-related assignment. Most of his days were devoted to lab work and he did little socialising. The participant described the second month of monitoring (dataset 2.2) as a very active period with weekend escapes and social events as well as a week-long trip to the family home abroad.

Participant 3, male living with his spouse, reported a most significant change in routine between the two investigated periods compared to other participants. During the second month of surveillance (dataset 3.2), he temporarily moved abroad (to Sweden) for voluntary hospital work. The trial ended soon after his return.

5.4.4.2 Coherence with analysis results

The key features of particular datasets are shown in Table 5-4. It was observed that reported routines were also apparent in the obtained results. Dataset 1.2 is characterised by only one high density cluster which would indicate that only one location was visited constantly and for long periods of time. This agrees with the participant's claim that the second month of monitoring was spent mostly at home including remote working, which caused the workplace not to be among the high-density clusters.

Dataset 2.2 contained a significantly higher number of clusters of each density compared with dataset 2.1. The fact that the most encountered Bluetooth device in the first dataset is the workplace computer coheres with the feedback given by the participant.

Datasets 3.1 and 3.2 show the change of lifestyle reported by the participant. Encounters with their spouse's phone are dominant in first period but non-existent in the second dataset. Also the locations of detected clusters shifted reflecting the fact of moving abroad.

Table 5-4 Analysis of multiple datasets

Subject	Dataset	Total number of clusters detected (high, medium, low density)	Avg. number of encounters per scan	Most encountered Bluetooth device
1	1.1	11 (2 , 3 , 6)	2.00	Not identified – related to 'Home' cluster
	1.2	7 (1 , 3 , 3)	1.87	Not identified – related to 'Home' cluster
2	2.1	12 (3 , 3 , 6)	2.75	Lab PC
	2.2	25 (4 , 13 , 8)	3.44	Partner's mobile phone
3	3.1	35 (4 , 9 , 22)	0.82	Spouse's phone
	3.2	25 (2 , 7 , 16)	0.40	Not identified – related to 'Place of residence abroad' cluster

What is more, it can be observed that periods described by participants as more social and active are characterised by a higher number of encounters per scan. This is likely to be caused by a higher number of other Bluetooth devices in crowded places usually connected with social activity (e.g. pub).

5.5 Summary

The concept of the PAM performed solely on a mobile phone was inspired by experiences resulting from earlier trials as well as from the feedback received from the psychiatric community. The commenced trial focused on information that it is possible to obtain from a smartphone which includes GPS position and Bluetooth encounters. The possibility of enhancing GPS positioning with GSM cell information was also explored. The tests consisted of participants carrying the phone (and in some cases a GPS keyring) for a period of three to eight weeks. Afterwards the results were analysed in order to extract behaviourally relevant information about significant locations and interactions. Using the DBSCAN algorithm allowed the identification of significant locations successfully validated by the participants. The process was then improved by utilising cell information according to a devised algorithm. Table 5-5 shows an analysis overview of all datasets included in the study. Detailed results for one dataset are shown within the chapter whereas others can be found in the appendix. Including cell network information improved the process of identifying clusters. However, it was discovered that low density clustering of data augmented with the use of GSM information can lead to false positives.

Table 5-5 Overview of GPS analysis

	Dataset						
	1.1	1.2	2.1*	2.2	3.1	3.2	4.1**
Weeks covered	4	4	4	4	4	4	3
No. of GPS points	457014	402953	137410	257244	403949	309355	88516
No. of points after preprocessing	98876	65916	71752	82610	227288	219725	12529
Percentage of points rejected due to low satellite count	34.14%	48.66%	10.82%	38.23%	13.23%	6.99%	85.85%
High density clusters	2	1	3	4	4	2	1
Med. density clusters	3	3	3	13	9	7	4
Low density clusters	6	3	6	8	22	16	3
Number of points reassigned using GSM	79346	75580	*	23636	18531	4374	**
High density clusters detected with GSM	2	2	*	5	4	2	**
Med. density clusters detected with GSM	5	4	*	12	10	9	**
Low density clusters detected with GSM	11	13	*	10	26	15	**
Number of false positives with GSM***	5	4	-	2	0	0	-

* - Dataset 2.1 does not include GSM cell information

** - GSM cell information could not be obtained in Uganda for dataset 4.1

*** - False positives occurred only within low density clusters

Analysis of Bluetooth encounters showed that such information can be utilised in several ways. Identifying the most frequently encountered devices, can provide insight into the number and times of interaction with users of these devices. In particular phones belonging to friends and spouses of participants of the study were identified.

Concurrently, frequently encountered devices can be often tied to one particular location (identified in earlier steps). Therefore, such encounters can be useful in enhancing the positioning process where GPS localisation is not available. For example, recording an encounter with a Bluetooth enabled work PC can cause the system to assume the position to be 'workplace' without using other means of obtaining location.

Moreover the number of encounters in a single scan can indicate a crowded location like bus or a city centre. This kind of information can also be useful in appraising the participant's social activity.

The combined data from both analyses were then used to explore differences within data collected from one participant over the course of two separate four week periods. In all cases participant-reported changes in their usual routine and behaviour could be related to a data input. Examples of such include:

- Increased number of detected significant locations cohering with a more active social life.
- Encountering workplace computer more often during periods of intensified work.
- Significant locations shifting drastically as a result of moving to another country.
- Increased number of Bluetooth encounters per scan during more 'social' times.

Such derivations render data collected from a mobile phone as a comprehensive source of behavioural information. Adding the inputs not included in the trials (e.g. acceleration data from the internal phone's sensor) could lead to an effective monitoring system that would be possible to achieve just by installing custom phone software without having to obtain additional hardware.

6 Discussion and Conclusions

This chapter summarizes the main results and outcomes of the work. It also presents a brief discussion on the future of PAM in mental health based on the experiences arising from the work.

6.1 Summary of work

This thesis has presented the premise, implementation and testing of a prototype sensor-based system which, it has been argued, could be applied to the pervasive care of the mentally ill. Considering the background, it was established that technology-aided methods of collecting information about patients' well-being are still not part of standard clinical practice in mental health. Despite the progress in ambulatory care including development of less obtrusive body worn sensors, such technology is yet to make its way into psychiatric treatment and monitoring regimes. Nevertheless, there are several examples of research on including computerised self-assessment, physiological measurements, actigraphy and other novel approaches in the field of psychiatry, which are presented in Chapter 1. These approaches constitute the research context for the PAM for the mentally ill, a sensor based support network for people with psychiatric conditions. For several reasons, including the occurrence of opposite behavioural extremes and its high cost to healthcare, BD was chosen as the main target for the proposed system. The primary aim was to create an "early warning" system able to detect changes of behaviour that could indicate an upcoming bipolar episode and generate alerts. Such alerts could significantly improve the patients' self-awareness which is crucial in any BD management regime.

These regimes along with the main symptoms, types and variations of the illness were presented in Chapter 2. Then, the key syndromes of manic and depressive episodes were matched with a non-invasive objective measure (e.g. psychomotor agitation in manic episodes can be observed via accelerometry). In these pairings, however, utilisation of physiological measurements was rejected due to their impracticability in a longitudinal monitoring scheme. Possible sensor configurations were discussed in terms of their intended placement (wearable and environmental) as well their possible architecture.

Chapter 3 presented the initial implementation of a first PAM prototype consisting of a wearable part with a mobile phone used as a hub and an environmental set of sensors to be set in the user's home. Both subsets contain off-the-shelf sensing solutions as well as custom devices designed and developed for this particular purpose. The technical trial that followed the development of the prototype was covered in Chapter 4, which also included an attempt to include bipolar patients in assessing the devised system. The sensor data collected in the technical trial was processed in order to extract basic behaviour patterns for particular sensors. The experiences from the technical trial were then used to reassess the setup and approach bipolar patients. However, due to potential participants withdrawing at various stages of the recruitment process, only one installation was performed.

During the trials, several compliance and acceptability issues were identified, which were mostly related to the wearable part of the system. It was discovered that participants were not likely to incorporate additional elements in their clothing, which was exhibited in low usage of the wearable sensors. This applied to the healthy volunteers as well as the sole BD patient participating in the trial.

The PAM trial along with initial feedback from the psychiatric community led to the conclusions that any additional device to be carried may cause compliance issues with prospective users. Therefore, the possibility of utilising a smartphone as the only means of

ambulatory monitoring was explored. During the investigation, involving four participants monitored over a period of up to eight weeks, location information along with Bluetooth encounters data was collected and then analysed. Positional data was subjected to clustering using a well established algorithm which led to identification of places meaningful to the participants, who validated the results. The methodology showed correlation between density of clusters and their significance for the subject. Attempts to improve the clustering process via utilising the cellular network information led to some improvements but also to false positives.

Bluetooth encounters provided information possible to utilise in three ways. Firstly, matching a discovered Bluetooth-enabled device with its user yielded, to some extent, insight into social activity of the participant. Secondly, frequently encountered devices that occurred in a single location identified in positional analysis may enhance the positioning process. Finally, high number of encountered devices in a single scan usually indicated presence in a crowded location, which information may also be of relevance for a monitoring system. Overall, the devised analysis methods revealed the possibilities of deriving information about a person's activity and social context based on inputs collectable from a mobile phone.

6.2 Key conclusions and discussion

Each stage of the work presented within this thesis resulted in key conclusions that were used to determine further steps. Reviewing current health service reports and academic publications revealed the growing problem of mental health and the existence of unmet needs within current healthcare systems. Moreover, it is apparent that the marginalised problems of people with mental illnesses will become an even greater burden in the near

future as their prevalence is expected to grow. BD sufferers were identified as a group which could potentially gain the most from an effective means of monitoring their current mental state. This is mostly due to the fact that an early recognition of bipolar episodes may result in a more successful intervention, but current clinical practice relies mostly on self-assessment in dealing with the disorder. Only a few research centres have attempted to implement a technology-led ambulatory monitoring system for people affected by the condition [54,59,62,64].

The premises described above drove the development and evaluation of a PAM prototype that included several sensory devices either worn by the users or placed in their home environment. Every evaluated element provided potentially useful data about the users' activity and patterns. However, many issues with the tested sensors and their implementations also became apparent, one of the main and most persistent being the impracticality of maintaining and "wearing" that many devices on a day to day basis. The sensor-specific gains and main problems that arose during the evaluation of the system are outlined in the table below (Table 6-1). It is worth noting that the concerns regarding the obtrusiveness do not apply to environmental sensors as they require minimal maintenance and, aside from the bed usage sensor, caused neither discomfort nor unease.

Table 6-1 The main gains and issues of individual PAM sensors

Sensor	Ambulatory relevant information	Main issues
Accelerometer	Viable physical activity measure	May not be worn in fixed position in relation to the body.
Wearable light sensor	Nature of the surroundings. Amount of daylight exposure (has clinical value)	Easily obscured by layers of clothing. Impracticable to wear on the outer garment on a day by day basis
Wearable microphone	Nature of the audible environment and detecting possible noise irritants Potential of sensing emotions	Obscured by clothing
GPS receiver	Shows daily routines and rhythms Out of ordinary behaviour and visits at unusual places	Ongoing surveillance may be deemed invasive
Environmental light sensor	Amount of daylight at home Detecting using the home lighting at unusual times	-
Environmental microphone	Nature of the audible environment at home	-
Motion sensors	At-home activity patterns Detects symptoms like unrestfulness	-
Bed usage sensor	Sleep patterns	Occurring privacy concerns Causing physical discomfort when placed on the bed

Some of the issues described above can possibly be rectified by changes in implementation. For example smart sensorised outer garments could facilitate collecting light and microphone readings along with other clinically relevant data [62]. Nevertheless, many of the inputs considered in the work, much as physiological measurements, might be not practicable to implement, despite the usefulness of provided data. Further insight into this aspect could be obtained by establishing user focus groups which were not employed in the described study. However, as stated earlier, the PAM project was supported by an advisory group consisting of clinicians and patients who provided initial user input.

Another factor that can contribute to the reduction of desired sensors is the interchangeability of the data they provide. Although no dedicated investigation was conducted, such links between data types could be observed. An example of such is that whilst the participant's presence indoors could be derived from decreased natural light and/or increased artificial light sensor readings, it was also characterised by the GPS sensor losing satellite link.

The combined experience of all implemented trials and tests led to the conclusion that a successful wearable monitoring system should not interfere with the user's routine and habits. Therefore pursuing monitoring via only a mobile phone was a logical choice for further investigations. This approach proved to show true potential in providing insight into a user's life to an extent unavailable by other means of sensor-based monitoring. Whilst BAN's aim to collect physiological measures, posture data and biological markers, the phone provides a means of observing the effects of behavioural routines in daily life. Information gained from GPS surveillance combined with Bluetooth interactions provided information about visited places, interacted individuals, daily routines, work schedule among other equally meaningful data. There is a definite potential of monitoring social and lifestyle patterns which is yet to be researched.

From the medical technology point of view, developing such a methodology can add a new dimension in tackling conditions known to affect the social and lifestyle patterns with psychiatric disorders being a flagship example.

6.3 Barriers

One of the main conclusions of the work presented in this thesis is that even relatively simple sensor inputs can provide useful information about a person's life and their patterns,

which may carry significant clinical information. However, the main obstructions for further development of novel management and diagnostic tools in psychiatry lie not in technology, but rather in addressing two main barriers:

- Clinical policies and practice – up to date, the technology-based approaches did not raise enough interest from the psychiatric community. Solutions ranging from non-complex electronically implemented assessment scales and text messaging prompts [54,58] to physiological measurements [44] have not yet made their way into the general practice.
- User compliance and acceptability – it was shown that adding even relatively small additional elements to clothing is likely to result in non-compliance and loss of data coverage. Moreover, some sensors despite their unobtrusiveness may be deemed unacceptable due to the nature of data stored.

The latter issue can to some extent be addressed during the system design process as sensors can and should be incorporated into everyday use devices and require minimal maintenance regimes. In this work it was shown that much can be achieved solely with a mobile phone, due to the fact that it is an appliance used and carried by users. As for acceptability of any sensor, it can be improved by applying on-sensor data processing which would extract only relevant information. This prevents any other sensitive data to be intercepted or maliciously used. In any case, dealing with the psychological and ethical impact of ongoing surveillance, regardless of the amount and nature of collected information, is a complex topic and a research field on its own [124,125].

Overcoming the first barrier described above requires deep policy changes and cooperation between researchers, clinicians and policymakers. Research needs to involve and inform the psychiatric community of positive outcomes of implemented studies. Only

then, modern technology-based approaches to mental care can be successfully rolled out and their true value appraised.

6.4 The future

The investigations conducted within this thesis show that developing an effective tool for managing and observing the course of psychiatric conditions is within reach but requires further effort especially in assessing user requirements and expectations among both clinicians and the patients. Some key issues and problems were identified on every level of the implementation process. Nevertheless, a clearer concept of a future PAM system emerges.

6.4.1 Elements

The following subsections briefly discuss the key elements of the envisioned system taking into consideration the experiences arising from the work conducted within this thesis. These elements would be the foundation of the proposed PAM scheme for patients with mental conditions outlined further in the text.

6.4.1.1 Mobile phone

The mobile phone should be the main hub and processing platform of the system. It is also justified that it is the only potentially viable “wearable” sensor. Moreover, smart-phones are capable of performing complex communication and processing tasks. This renders it as an ideal hub for any user-centred monitoring system.

As functionalities of modern phones grow, the amount of significant patient information possible to collect will increase. The inputs researched in-depth in this thesis: location services (GPS and GSM based) and Bluetooth encounters monitoring could be expanded

with data collected from the phone's internal accelerometers, light detectors etc. On top of that, the way the phone itself is used could provide information which might prove useful. Speed of typing, amount of text communication are just as representative of one's lifestyle as the measures utilised in the studies conducted here. It is likely that continuous advancements in sophistication and complexity of phone operating systems will facilitate the customisation of the smart-phone software to serve as a PAM tool.

6.4.1.2 The environmental sensors

The environmental part of the system should consist of a set of simple and unobtrusive sensors spread within the home environment. The sensors as researched within this thesis were able to acquire potentially useful information and required little maintenance from the user. To simplify the setup, those sensors could communicate with the hub (phone) directly, using Bluetooth as a communication system. They could be provided as an addition to the phone based system, enhancing its functionality and providing more data. However, the cost for the user, aside from the price of hardware itself, would be the need to install and maintain additional devices in home.

6.4.1.3 Processing and feedback

As shown in this work, applying simple processing to the sensor data can provide behavioural information. It can be either processed further to extract more complex life patterns or fed back to the user or their clinician to allow them to derive information about the significance of the data. The latter option is more likely to be accepted by clinicians and patients as it provides more control and an overview on the type of information collected and removes the notion of a computer "making decisions".

6.4.1.4 Deployment

Provided that the envisioned phone-based system could be functional without any additional devices and sensors, it is possible that a PAM-specific application could be distributed and deployed via means available to any other mobile software. Most current mobile platforms offer custom software available via open market places where such an application could be distributed. Users could then use the system and observe the outcomes (i.e. the processed data patterns). This can be used to enhance self-reported information and improve the treatment process. The route described here may be the most promising way of reaching users that could benefit from using a non-traditional approach to their treatment.

6.4.2 The general scheme

The way the PAM system might work could be described by the following sequence:

1. Patients either wishing to gain better understanding of their condition or following advice from their clinician register to a PAM service.
2. The service provides patients with a software suite realising PAM on the user's own phone. In case of the device not being advanced enough to effectively run the suite, guidelines would be provided to purchase a suitable device on the market.
3. The user equipped with the software uses it to collect data which is then processed on the phone. For complex processing the user may be asked to send the data to a more powerful server provided by the PAM service.
4. The data is then presented to the user in an understandable manner highlighting changes to behaviour that occurred during the monitored period. The patients could then decide to act on the received information according to their judgment.

Alternatively the information can be shown to the clinician to enhance their assessment of the patient's current state.

5. Patients and clinicians could be asked to provide feedback on accuracy and correctness of the analysis which could be then used to improve the service.
6. Additionally, as an option, the PAM service could suggest additional devices to be installed in the users' home (i.e. environmental sensors). These could be third party off-the-shelf devices possible to pair with the PAM system via Bluetooth.

The scheme provides a viable and easily implementable way of taking advantage of modern technology to provide help for mental care patients. It is worth noting that the system, as proposed, would play only a supporting role in the process of facilitating mental care rather than aim to replace the established practice. With the cooperation from the psychiatric community, PAM could become a very useful tool improving the outcome of treatment of BD as well as other psychiatric conditions.

Appendix A. Trial results of PAM on phone

This appendix presents data and analysis results of the trial described in Chapter 5. The following figures and tables are generated from remaining datasets collected during the trial and not presented in the chapter itself. The pre-processing steps as well as methodology of extracting significant places is also described in-depth in Chapter 5.

Table 1. Overview of the datasets

	Dataset						
	1.1	1.2	2.1*	2.2	3.1	3.2	4.1**
Weeks covered	4	4	4	4	4	4	3
No. of GPS points	457014	402953	137410	257244	403949	309355	88516
No. of points after preprocessing	98876	65916	71752	82610	227288	219725	12529
Percentage of points rejected due to low satellite count	34.14%	48.66%	10.82%	38.23%	13.23%	6.99%	85.85%
High density clusters	2	1	3	4	4	2	1
Med. density clusters	3	3	3	13	9	7	4
Low density clusters	6	3	6	8	22	16	3
Number of points reassigned using GSM	79346	75580	*	23636	18531	4374	**
High density clusters detected with GSM	2	2	*	5	4	2	**
Med. density clusters detected with GSM	5	4	*	12	10	9	**
Low density clusters detected with GSM	11	13	*	10	26	15	**

* - Dataset 2.1 does not include GSM cell information

** - GSM cell information could not be obtained in Uganda for dataset 4.1

A.1 Participant 1

The trial for the Participant 2 lasted for eight weeks. The results consist of two datasets 1.1 and 1.2 each consisting four weeks of data.

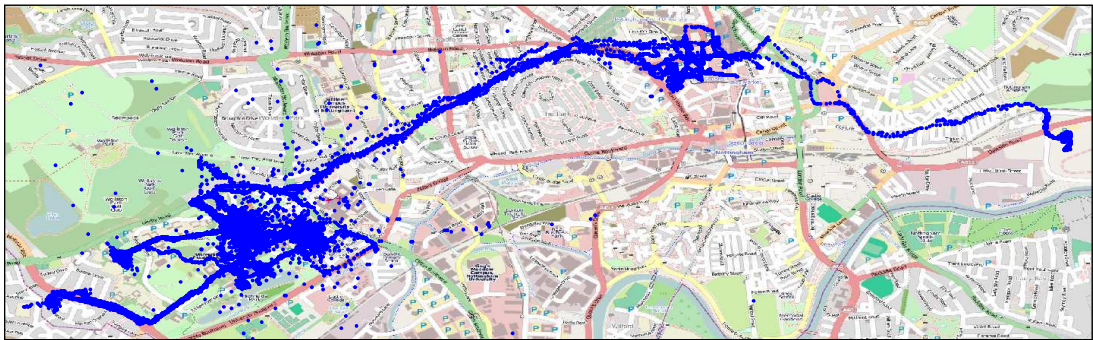

Figure 1. GPS tracks in dataset 1.1

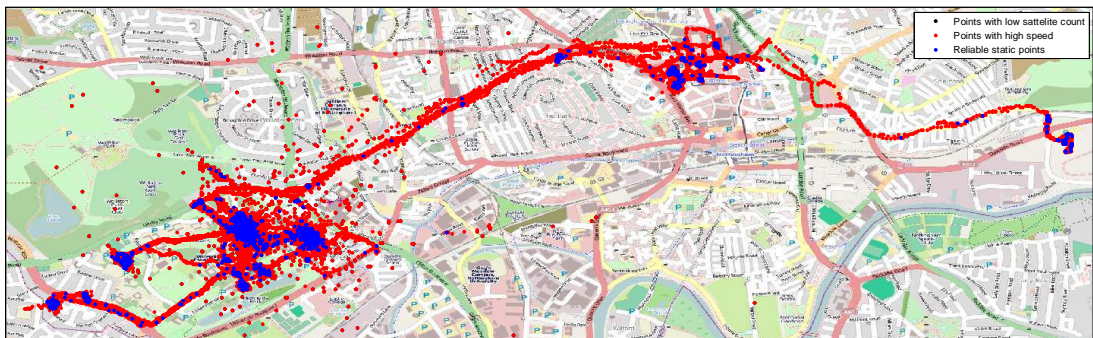

Figure 2. Pre-processing of dataset 1.1

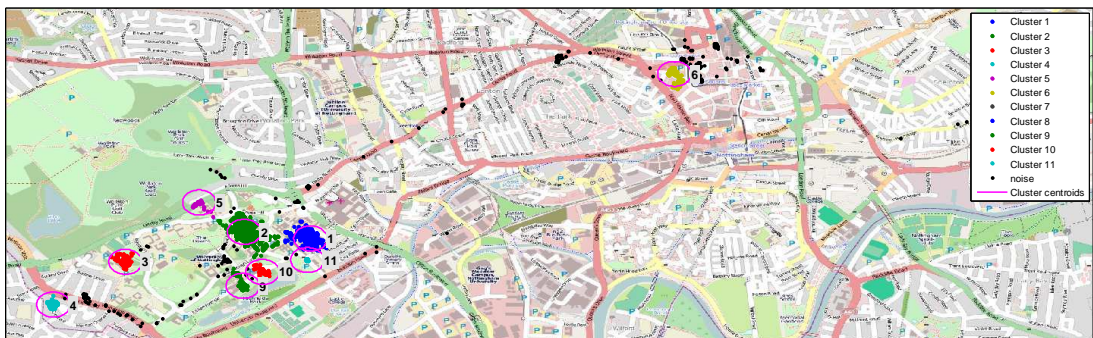

Figure 3. Clustering of dataset 1.1

Table 2. Cluster verification in dataset 1.1

Cluster number	MinPts parameter	Description given by participant		
		Place	Times visited	Avg. duration
1	5000 (high)	Workplace	Constantly	Hours
2	5000 (high)	Home	Constantly	Hours
3	500 (med)	Sports centre (gym)	Often	1 hour
4	500 (high)	Friend's house (1)	Several	2-3 hours
5	150 (low)	Bus stop	Several	< 15 minutes
6	150 (low)	City Centre	Several	1 hour
7	150 (low)	Sunday market	Once	1 hour
8	150 (low)	Bus stop	Once	< 15 minutes
9	500 (med)	Campus pub/cafeteria	Several	1 hour
10	150 (low)	Bus stop	Twice	< 15 minutes
11	150 (low)	Bus stop	Once	< 15 minutes

Table 3. Including GSM information for dataset 1.1

	Using GPS	Using GPS and Cell ID
Number of geospatial points		457014
Number of points after pre-processing	98876	178222
High density clusters (successfully identified)	2(2)	2(2)
Number of med. density clusters (successfully identified)	3(3)	5(5)
Number of low density clusters (successfully identified)	6(6)	11(6)
Total clusters	11	18
Successfully identified clusters	11	13
False positives	0	5

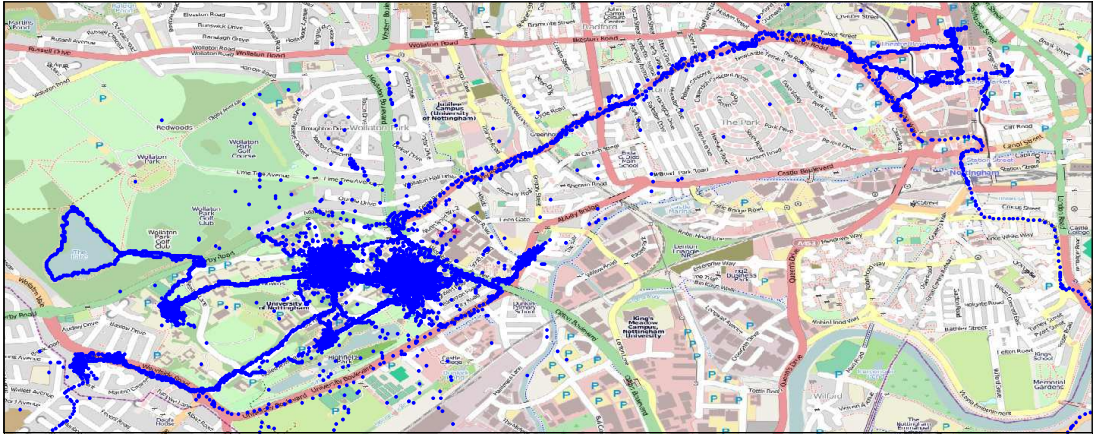

Figure 4. GPS tracks in dataset 1.2

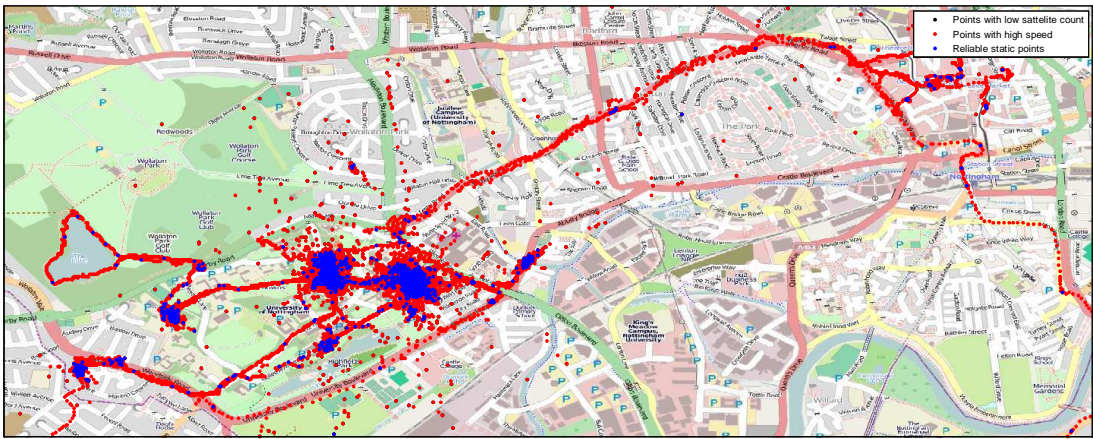

Figure 5. Pre-processing of dataset 1.2

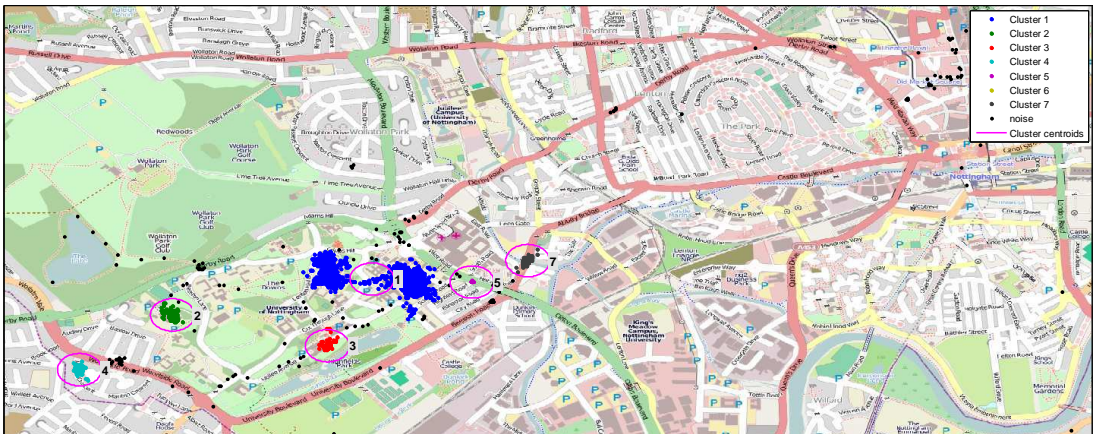

Figure 6. Clustering of dataset 1.2

Table 4. Cluster verification in dataset 1.2

Cluster number	MinPts parameter	Description given by participant		
		Place	Times visited	Avg. duration
1	5000 (high)	Home / Workplace	Constantly	Hours
2	500 (med)	Sports centre (gym)	Often	1 hour
3	150 (low)	Bus stop	Several	< 15 minutes
4	500 (med)	Friend's house (1)	Several	2-3 hours
5	150 (low)	Bus stop	Several	< 15 minutes
6	500 (med)	Family home	Once	Hours
7	150 (low)	Pub	Once	1 hour

Table 5. Including GSM information for dataset 1.2

	Using GPS	Using GPS and Cell ID
Number of geospatial points		402953
Number of points after pre-processing	65916	141496
High density clusters (successfully identified)	1 (1)	2 (2)
Number of med. density clusters (successfully identified)	3 (3)	4 (4)
Number of low density clusters (successfully identified)	3 (3)	13 (9)
Total clusters	7	19
Successfully identified clusters	7	15
False positives	0	4

A.2 Participant 2

The trial for the Participant 2 lasted for eight weeks. The results consist of two datasets 2.1 and 2.2 each consisting four weeks of data.

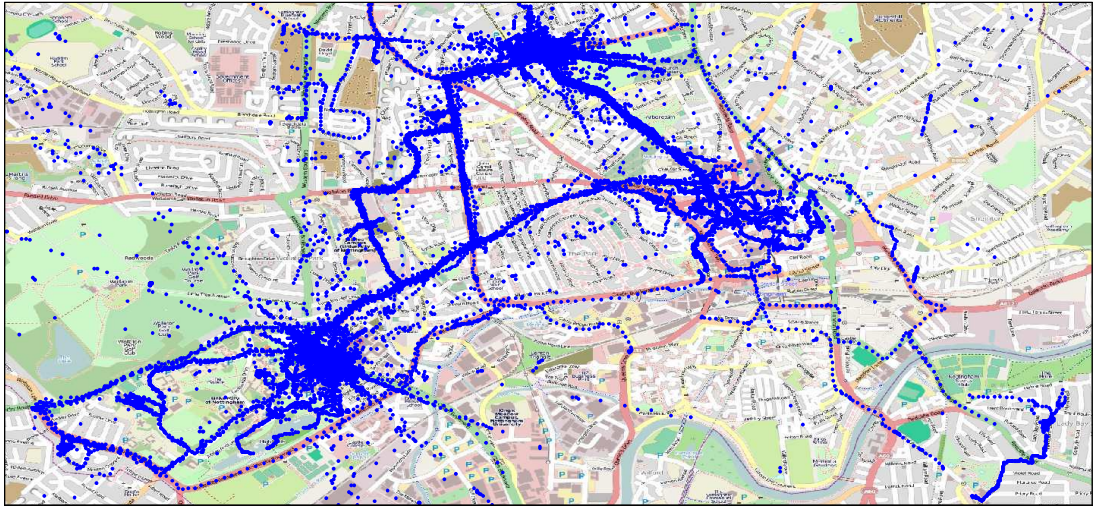

Figure 7. The majority of GPS tracks in dataset 2.1

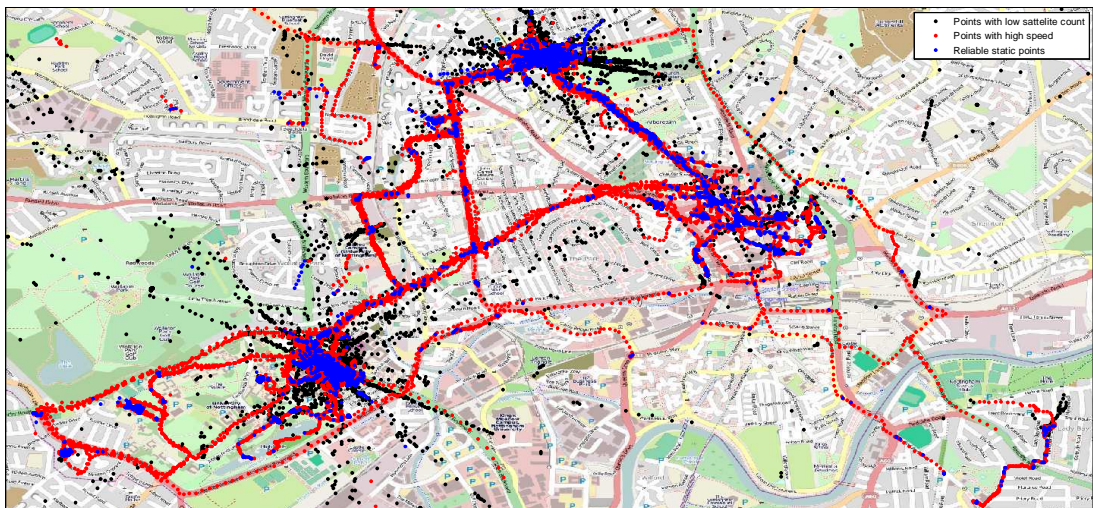

Figure 8. Pre-processing of dataset 2.1

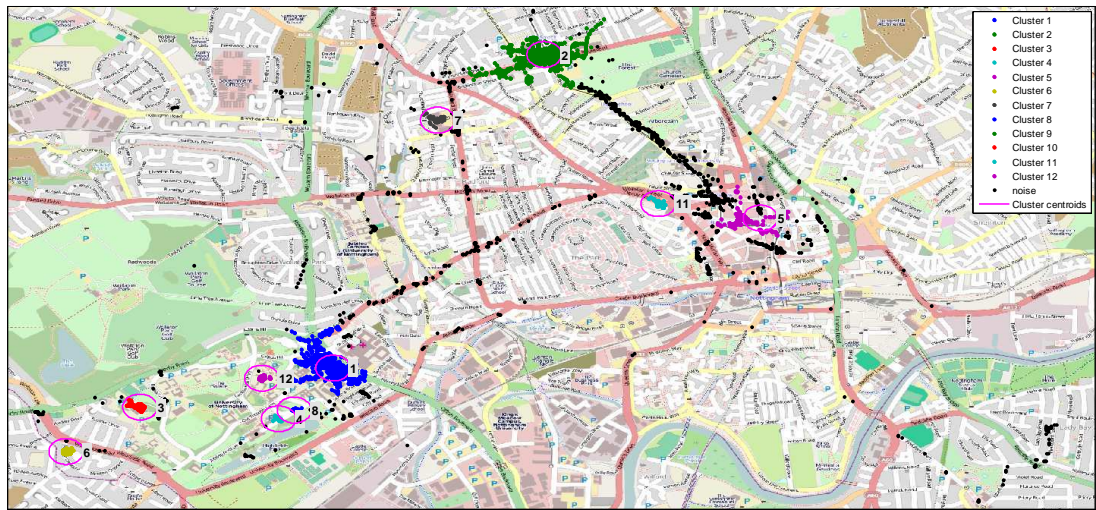

Figure 9. The majority of clusters identified in dataset 2.1

Table 6. Cluster verification in dataset 2.1

Cluster number	MinPts parameter	Description given by participant		
		Place	Times visited	Avg. duration
1	5000 (high)	Workplace	Constantly	Hours
2	5000 (high)	Home	Constantly	Hours
3	500 (med)	Sports centre (gym)	Often	1 hour
4	150 (low)	Bus stop	Several	< 15 minutes
5	500 (med)	City centre	Several	1-2 hours
6	5000 (high)	Friend's house (1)	Several	2-3 hours
7	150 (low)	Shopping centre	Once	1 hour
8	150 (low)	Bus stop	Several	< 15 minutes
9	150 (low)	Castle	Once	1-2 hours
10	500 (med)	Pub	Once	3 hours
11	150 (low)	Church	Once	Hour
12	500 (med)	Friend's house (2)	Once	Hours

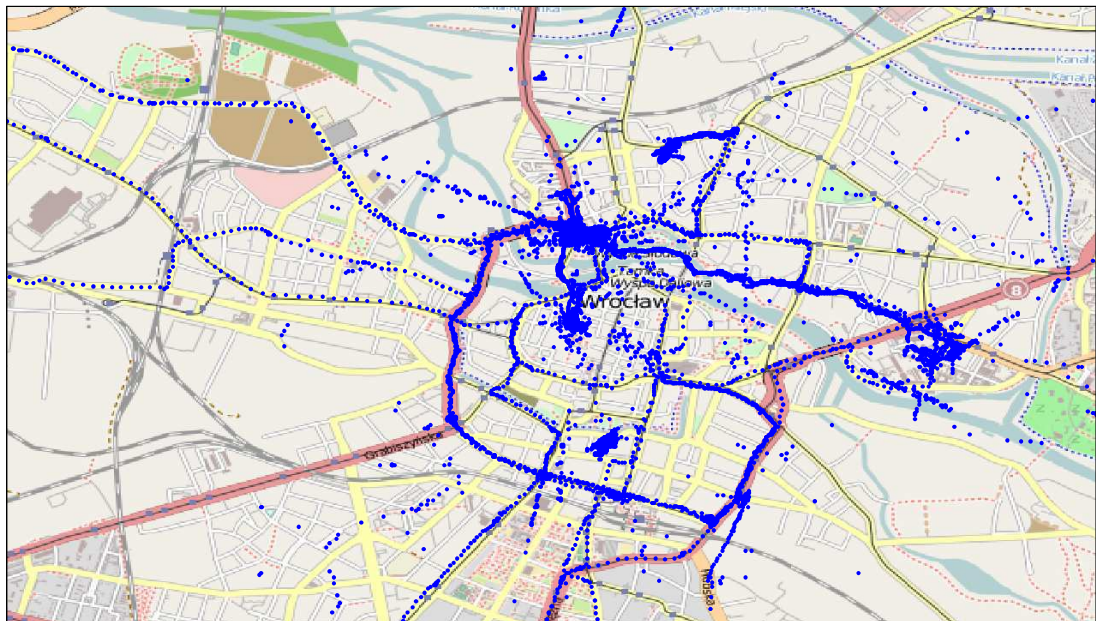
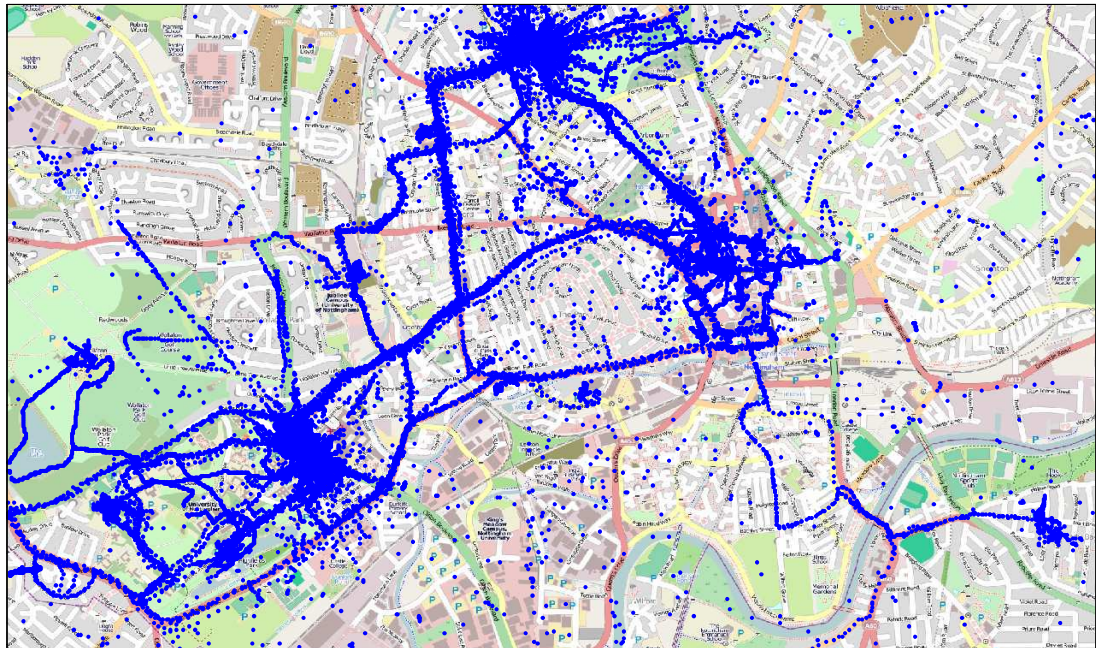

Figure 10. The majority of GPS tracks in dataset 2.2 from Nottingham, UK (top) and Wrocław, Poland (bottom)

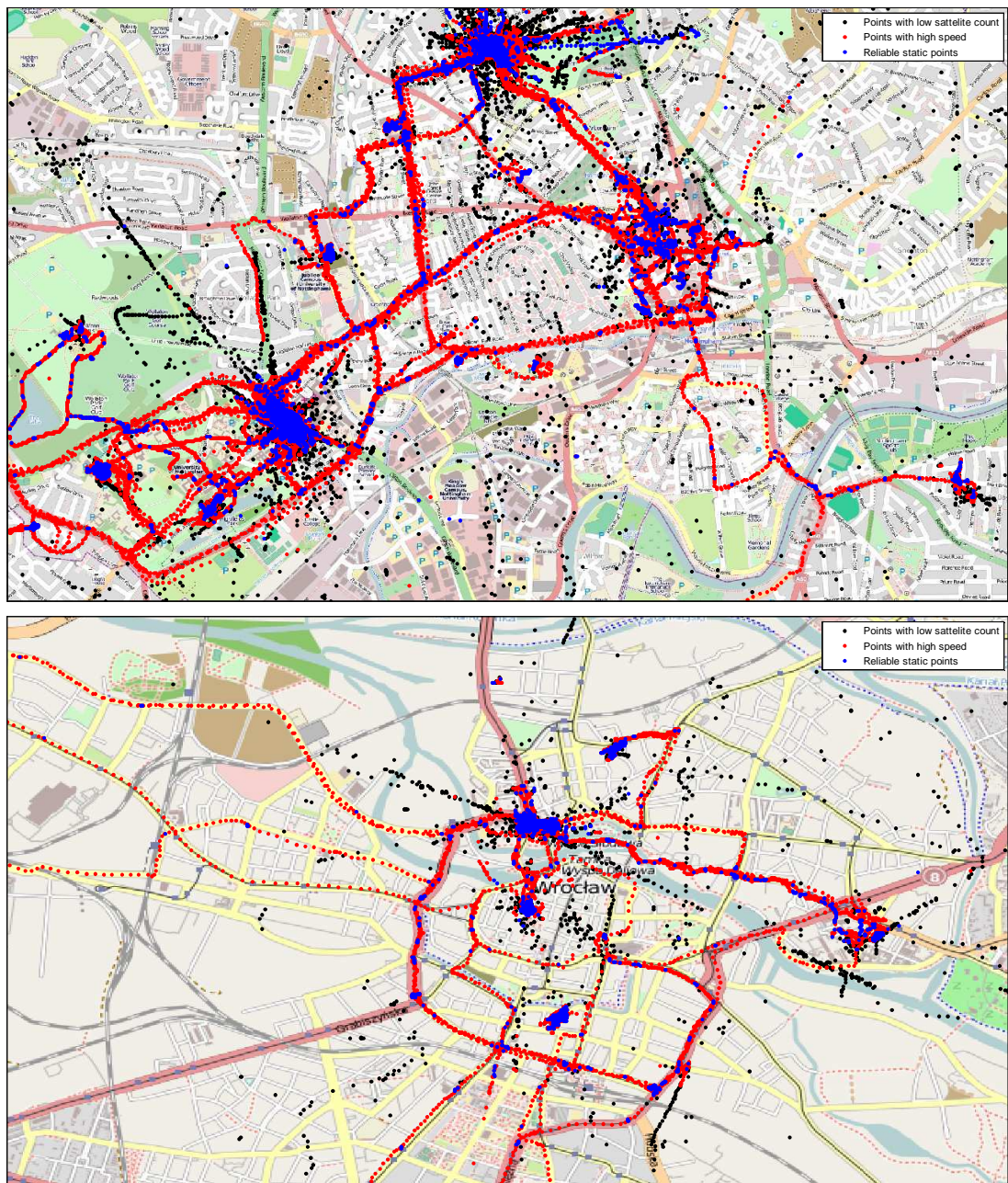

Figure 11. Pre-processing of dataset 2.2

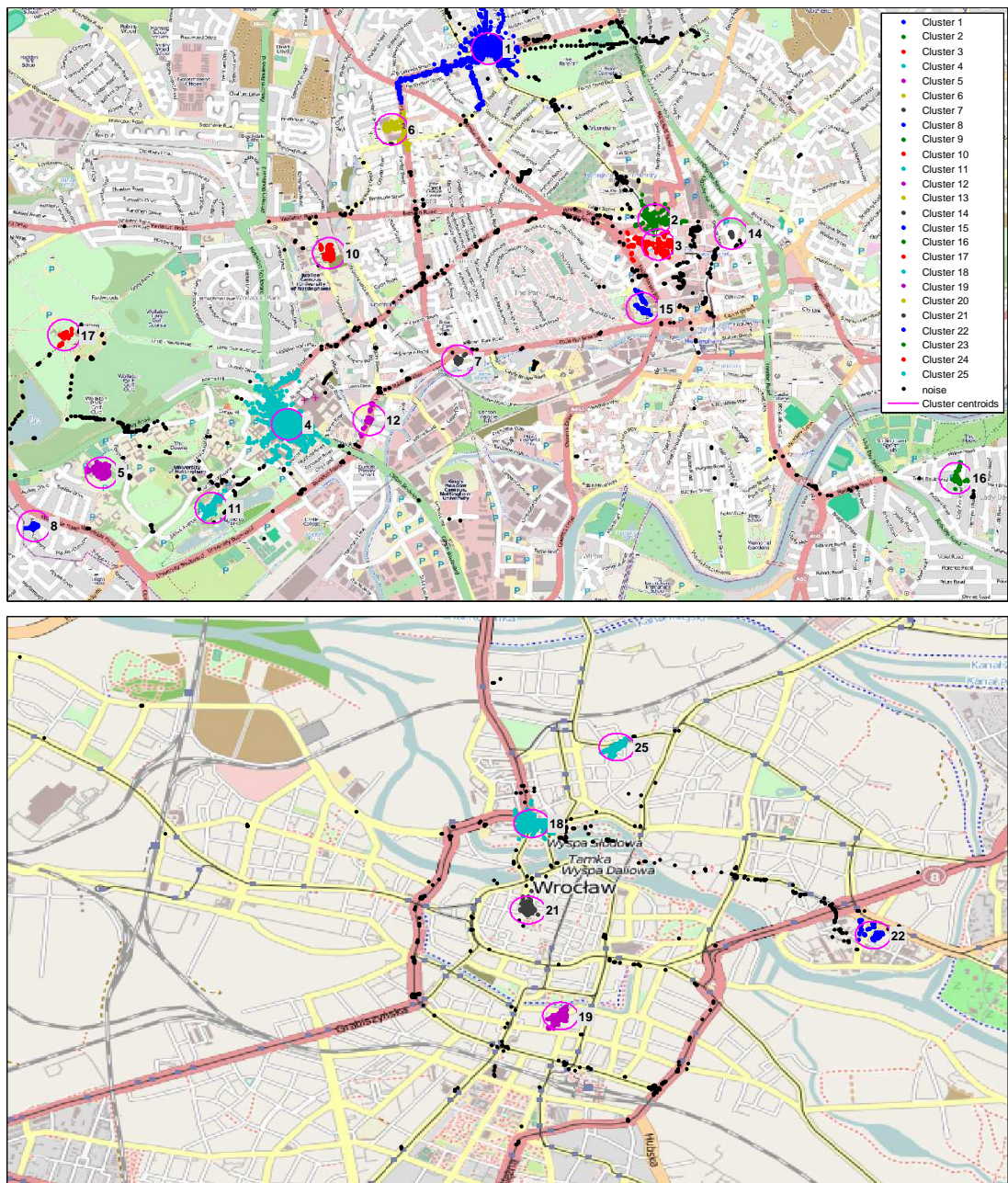

Figure 12. The majority of clusters identified in dataset 2.2

Table 7. Cluster verification in dataset 2.2

Cluster number	MinPts parameter	Description given by participant		
		Place	Times visited	Avg. duration
1	5000 (high)	Home	Constantly	Hours
2	150 (low)	Bus stop	Several	< 15 minutes
3	150 (low)	City centre	Several	1-2 hours
4	5000 (high)	Workplace	Constantly	Hours
5	500 (med)	Sports centre	Often	1 hour
6	500 (med)	Shopping centre	Once	1 hour
7	500 (med)	Friend's house (1)	Once	Hours
8	5000 (high)	Friend's house (2)	Several	Hours
9	150 (low)	Friend's house (3)	Once	2 Hours
10	500 (med)	Conference centre	Once	4 hours
11	500 (med)	Café	Several	Hour
12	500 (med)	Pub	Once	3 Hours
13	5000 (high)	Friend's house (4)	Once	2 days
14	150 (low)	Cinema	Once	2 Hours
15	150 (low)	Castle	Once	1-2 hours
16	500 (med)	Friend's house (5)	Once	Hours
17	150 (low)	Bus stop	Several	< 15 minutes
18	500 (med)	Family home	Several	Hours
19	500 (med)	Friend's house (6)	Several	2-3 hours
20	500 (med)	Shopping centre	Once	3 hours
21	500 (med)	Sister's house	Several	1-2 Hours
22	150 (low)	Friend's house (7)	Once	1 hour
23	500 (med)	Friend's house (8)	Once	2-3 hours
24	150 (low)	In-laws' house	Once	1 hours
25	500 (med)	Friend's house (9)	Once	2-3 hours

Table 8. Including GSM information for dataset 2.2

	Using GPS	Using GPS and Cell ID
Number of geospatial points		257244
Number of points after pre-processing	82610	106246
High density clusters (successfully identified)	4 (4)	5 (5)
Number of med. density clusters (successfully identified)	8 (8)	12 (12)
Number of low density clusters (successfully identified)	13 (13)	10 (8)
Total clusters	25	25
Successfully identified clusters	25	27
False positives	0	2

A.3 Participant 3

The trial for the Participant 3 lasted for eight weeks. The results consist of two datasets 3.1 and 3.2 each consisting four weeks of data.

The GPS tracks of the Participant 3 during the monitored period were spread around numerous regions of three countries (UK, Sweden and Poland). Therefore, it is impracticable to present those tracks as a set of figures as for the other participants. Therefore tables regarding the improvement of clustering with GSM cell information are enclosed.

Table 9. Including GSM information for dataset 3.1

	Using GPS	Using GPS and Cell ID
Number of geospatial points		403949
Number of points after pre-processing	227288	245819
High density clusters (successfully identified)	4 (4)	4 (4)
Number of med. density clusters (successfully identified)	9 (9)	10 (10)
Number of low density clusters (successfully identified)	22(22)	26(26)
Total clusters	35	40
Successfully identified clusters	35	40
False positives	0	0

Table 10. Including GSM information for dataset 3.2

	Using GPS	Using GPS and Cell ID
Number of geospatial points		309355
Number of points after pre-processing	219725	224099
High density clusters (successfully identified)	2 (2)	2 (2)
Number of med. density clusters (successfully identified)	7 (7)	9 (9)
Number of low density clusters (successfully identified)	16 (16)	15 (15)
Total clusters	25	26
Successfully identified clusters	25	26
False positives	0	0

A.4 Participant 4

The trial for the Participant 4 lasted for three weeks. The results consist of one dataset 4.1 consisting of three weeks of data.

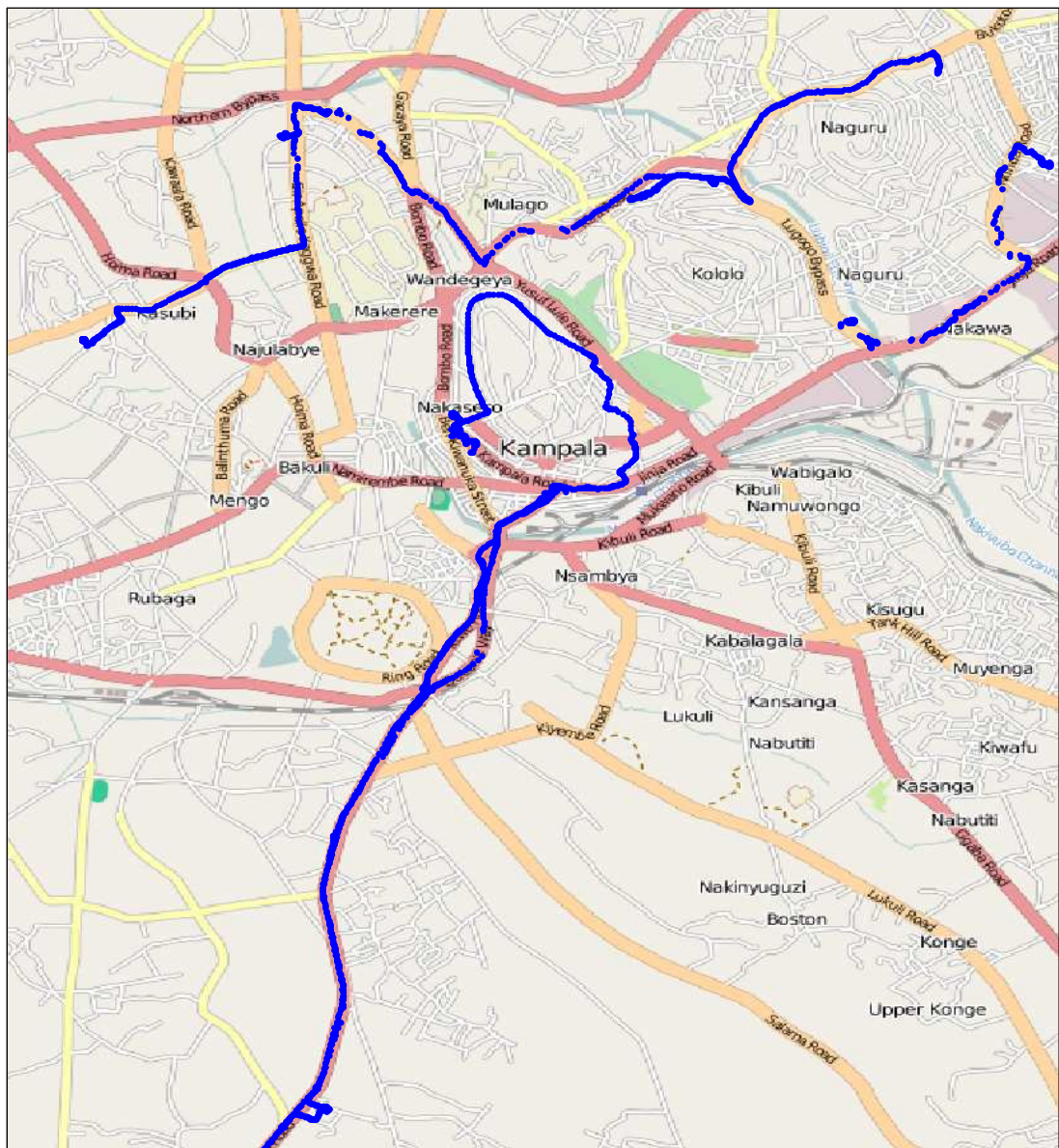

Figure 13. The majority of GPS tracks in dataset 4.1

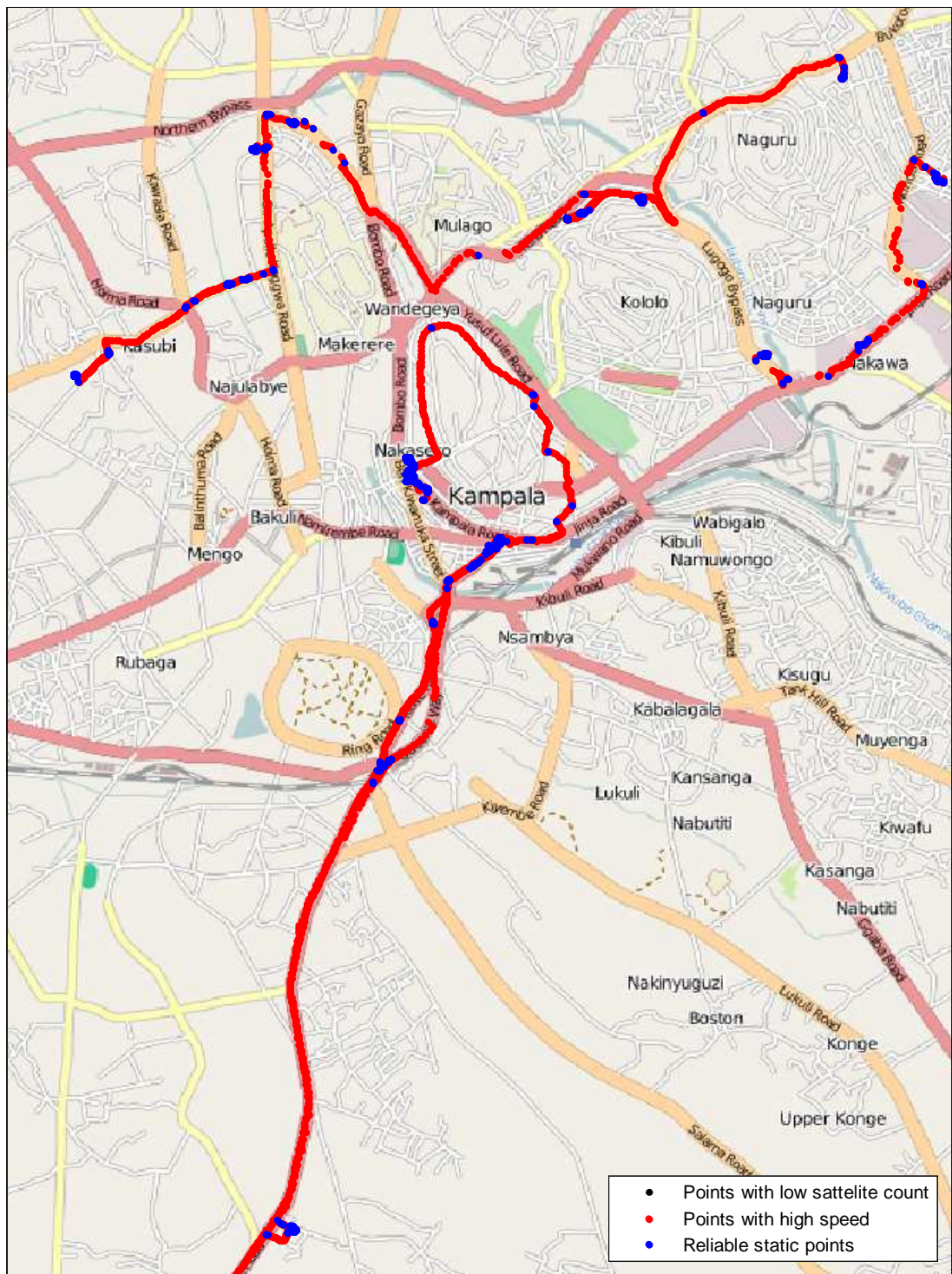

Figure 14. Pre-processing of dataset 4.1

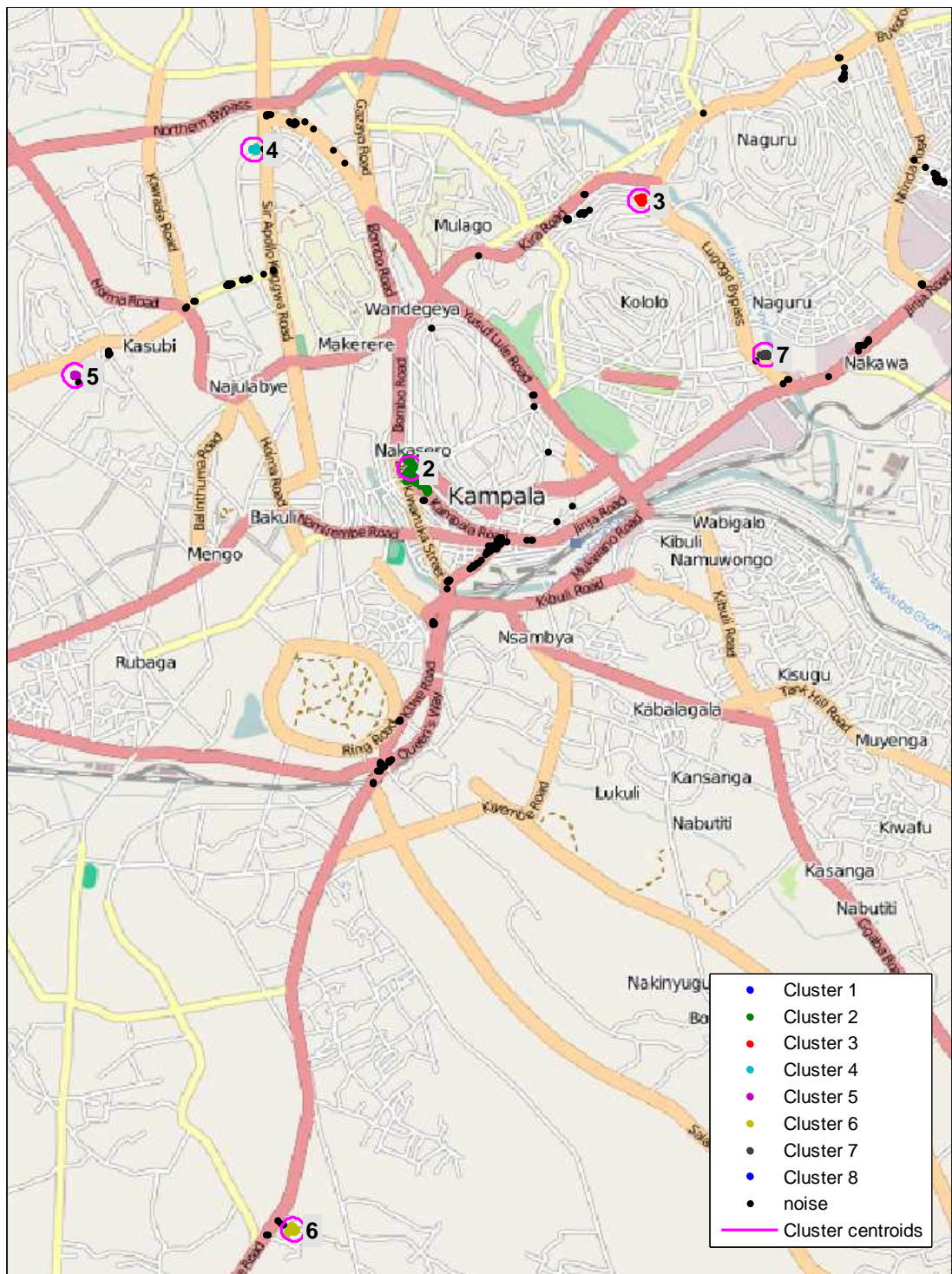

Figure 15. The majority of clusters identified in dataset 4.1

Table 11. Cluster verification in dataset 4.1

Cluster number	MinPts parameter	Description given by participant		
		Place	Times visited	Avg. duration
1	500 (med)	Airport	Twice	3 hours
2	500 (med)	City centre	Several	1 hour
3	500 (med)	Friend's house	Once	3 Hours
4	150 (low)	Shop	Once	< 15 minutes
5	500 (med)	Friend's house	Twice	1-2 hours
6	150 (low)	Petrol station	Twice	20 minutes
7	5000 (high)	Family home	Many	Hours
8	150 (low)	Airport parking	Twice	15 minutes

Appendix B. The PAM reading's file

Introduction

This non-normative document discusses an XML file format for the storage of sensor network readings from heterogeneous devices in a single file. The format is intended to allow readings from different devices to be interlaced throughout the file, be able to group readings into sets of readings (`reading_set`), and keep verbosity to a minimum in order to maximise battery-powered device lifetimes. The intended audience of this document includes application developers whose programs read and write sensor network readings.

XML files are plain text. They are human-readable and understandable. On the downside, XML files can be overly verbose or complex, but that can be managed. The file format has been chosen to distinguish readings from multiple sensors in the same file in order to keep the file count low.

The normative XML schema describing the format and sample XML instance files can be found at: <http://www.cs.stir.ac.uk/~jmb/pam/readingXml/> . The schema may be used to validate readings files.

Readings file description

Readings files are composed of XML elements. The main elements of readings files are:

- Reading file
- Readings
- Reading set
- Simple reading
- Complex reading
- Reading part

Reading file (<readingFile>)

The reading file element is the root element of each file. It may contain a comment followed by a single readings element (<readings>), which contains a sequence of reading sets optionally followed by simple readings or complex readings.

Reading set (<readingSet>)

Reading set elements either contain simple readings or complex readings, or are self closing elements that are subsequently referenced by simple readings or complex readings. Reading set elements have id attributes that serve two purposes. The id is required and should contain a timestamp of when the reading set was created. The value should be represented as a long integer corresponding to the the number of milliseconds since January 1, 1970, 00:00:00 GMT.

Simple reading (<sr>)

The simple reading element describes a reading taken by a device. A device reading may contain different parts (such as X, Y and Z coordinates) but the simple reading element does not distinguish these parts and the XML file author will need to adopt a convention (such as comma separation) for distinguishing the parts.

Complex reading (<cr>)

The complex reading element also describes a reading taken by a device. It contains reading parts (<rp>) elements to distinguish the different parts of a reading.

Referencing reading sets

Simple reading and complex reading elements may be added to readingSet or readings. If added to <readings> then they should include a "ref" attribute with the value of the reading set id attribute value that they belong to.

References

- [1] H.-U. Wittchen and F. Jacobi, "Size and burden of mental disorders in Europe--a critical review and appraisal of 27 studies.," *European neuropsychopharmacology : the journal of the European College of Neuropsychopharmacology*, vol. 15, Aug. 2005, pp. 357-76.
- [2] C.J.L. Murray and A.D. Lopez, *The global burden of disease 2004*, Harvard University Press, 2004.
- [3] W.W. Eaton, S.S. Martins, G. Nestadt, O.J. Bienvenu, D. Clarke, and P. Alexandre, "The burden of mental disorders.," *Epidemiologic Reviews*, vol. 30, 2008, pp. 1-14.
- [4] A.D. Lopez, C.D. Mathers, M. Ezzati, D.T. Jamison, and C.J.L. Murray, *Global Burden of Disease and Risk Factors*, World Bank Publications, 2006.
- [5] T.B. Ustün, "The global burden of mental disorders," *American Journal of Public Health*, vol. 89, 1999, pp. 1315-1318.
- [6] C.D. Mathers and D. Loncar, "Projections of Global Mortality and Burden of Disease from 2002 to 2030," *PLoS Medicine*, vol. 3, 2006, p. 20.
- [7] U.W. Ebner-Priemer and T.J. Trull, "Ambulatory Assessment: An Innovative and Promising Approach for Clinical Psychology," *European Psychologist*, vol. 14, Jan. 2009, pp. 109-119.
- [8] J. Fahrenberg, M. Myrtek, K. Pawlik, and M. Perrez, "Ambulatory Assessment - Monitoring Behavior in Daily Life Settings," *European Journal of Psychological Assessment*, vol. 23, Jan. 2007, pp. 206-213.
- [9] B.A. Tobias, J.F. Kihlstrom, D.L. Schacter, and S.-A. Christianson, "Emotion and implicit memory," Lawrence Erlbaum Associates, 1992, pp. 67-92.
- [10] S.N. Haynes and D.T. Yoshioka, "Clinical assessment applications of ambulatory biosensors.," *Psychological assessment*, vol. 19, Mar. 2007, pp. 44-57.
- [11] T.R.H. Cutmore and D.A. James, "Sensors and Sensor Systems for Psychophysiological Monitoring," *Journal of Psychophysiology*, vol. 21, Jan. 2007, pp. 51-71.
- [12] E. Coiera, "Essentials of Telemedicine and Telecare," *BMJ British Medical Journal*, vol. 324, 2002, p. 1104.

- [13] C.S. Pattichis, E. Kyriacou, and S. Voskarides, "Wireless Telemedicine Systems : An Overview," *IEEE Antennas and Propagation Magazine*, vol. 44, 2002, pp. 143-153.
- [14] J. Crowe, B. Hayes-Gill, B. Francon, L. Hardebecke, D. Rogers, Y. Thong, P. Dimmock, K. Wyatt, and P. O'Brien, "Customisation of a personal digital assistant for logging premenstrual syndrome symptoms," *British Journal of Healthcare Computing & Information Management*, vol. 17, 2000, pp. 33-35.
- [15] S. Krishna, S.A. Boren, and E.A. Balas, "Healthcare via cell phones: a systematic review.," *Telemedicine journal and e-health : the official journal of the American Telemedicine Association*, vol. 15, Apr. 2009, pp. 231-40.
- [16] S.J. Lane, N.M. Heddle, E. Arnold, and I. Walker, "A review of randomized controlled trials comparing the effectiveness of hand held computers with paper methods for data collection.," *BMC medical informatics and decision making*, vol. 6, Jan. 2006, pp. 23-26.
- [17] R. Van Emmerik and R. Wagenaar, "Dynamics of movement coordination and tremor during gait in Parkinson's disease," *Human Movement Science*, vol. 15, Apr. 1996, pp. 203-235.
- [18] B. Dijkstra, Y.P. Kamsma, and W. Zijlstra, "Detection of gait and postures using a miniaturized triaxial accelerometer-based system: accuracy in patients with mild to moderate Parkinson's disease.," *Archives of physical medicine and rehabilitation*, vol. 91, Aug. 2010, pp. 1272-7.
- [19] A.V. Ng and J.A. Kent-Braun, "Quantitation of lower physical activity in persons with multiple sclerosis.," *Medicine and science in sports and exercise*, vol. 29, Apr. 1997, pp. 517-23.
- [20] E.M. Snook, R.W. Motl, and R.C. Gliottoni, "The effect of walking mobility on the measurement of physical activity using accelerometry in multiple sclerosis.," *Clinical rehabilitation*, vol. 23, Mar. 2009, pp. 248-58.
- [21] J. Chen, K. Kwong, D. Chang, J. Luk, and R. Bajcsy, "Wearable sensors for reliable fall detection.," *Conference proceedings : ... Annual International Conference of the IEEE Engineering in Medicine and Biology Society. IEEE Engineering in Medicine and Biology Society. Conference*, vol. 4, Jan. 2005, pp. 3551-4.
- [22] Q. Li, J.A. Stankovic, M.A. Hanson, A.T. Barth, J. Lach, and G. Zhou, "Accurate, Fast Fall Detection Using Gyroscopes and Accelerometer-Derived Posture Information," *2009 Sixth International Workshop on Wearable and Implantable Body Sensor Networks*, IEEE, 2009, pp. 138-143.
- [23] M. Fukakusa, T. Sato, and H. Furuhashi, "[Use of an accelerometer to measure coughing].," *Nihon Kokyūki Gakkai zasshi = the journal of the Japanese Respiratory Society*, vol. 36, Apr. 1998, pp. 343-6.

- [24] M.J. Mathie, A.C.F. Coster, N.H. Lovell, and B.G. Celler, "Accelerometry: providing an integrated, practical method for long-term, ambulatory monitoring of human movement," *Physiological Measurement*, vol. 25, Apr. 2004, p. R1-R20.
- [25] A. Pantelopoulos and N.G. Bourbakis, "A Survey on Wearable Sensor-Based Systems for Health Monitoring and Prognosis," *IEEE Transactions on Systems Man and Cybernetics Part C Applications and Reviews*, vol. 40, 2010, pp. 1-12.
- [26] X. Hong, C. Nugent, M. Mulvenna, S. McClean, B. Scotney, and S. Devlin, "Evidential fusion of sensor data for activity recognition in smart homes," *Pervasive and Mobile Computing*, vol. 5, Jun. 2009, pp. 236-252.
- [27] J. Pansiot, D. Stoyanov, D. McIlwraith, B. Lo, and G.-Z. Yang, "Ambient and Wearable Sensor Fusion for Activity Recognition in Healthcare Monitoring Systems," *IFMBE proc of the 4rd International Workshop on Wearable and Implantable Body Sensor Networks 2007 BSN07*, S. Leonhardt, T. Falck, and P. Mähönen, eds., Springer Berlin Heidelberg, 2007, pp. 208-212.
- [28] L. Weyandt, *The physiological bases of cognitive and behavioral disorders*, Lawrence Erlbaum Associates, 2006.
- [29] M.H. Teicher, "Actigraphy and motion analysis: new tools for psychiatry.," *Harvard review of psychiatry*, vol. 3, 1995, pp. 18-35.
- [30] J.B.J. Bussmann, U.W. Ebner-Priemer, and J. Fahrenberg, "Ambulatory Activity Monitoring," *European Psychologist*, vol. 14, Jan. 2009, pp. 142-152.
- [31] F. Wilhelm and W.T. Roth, "The somatic symptom paradox in DSM-IV anxiety disorders: suggestions for a clinical focus in psychophysiology," *Biological Psychology*, vol. 57, Aug. 2001, pp. 105-140.
- [32] J. Fahrenberg, "Assessment in daily life. A review of computer-assisted methodologies and applications in psychology and psychophysiology, years 2000–2005," *Psychological Assessment*, vol. 29, 2006, p. 2008.
- [33] L. Fratiglioni, L.J. Launer, K. Andersen, M.M. Breteler, J.R. Copeland, J.F. Dartigues, A. Lobo, J. Martinez-Lage, H. Soininen, and A. Hofman, "Incidence of dementia and major subtypes in Europe: A collaborative study of population-based cohorts. Neurologic Diseases in the Elderly Research Group.," *Neurology*, vol. 54, Jan. 2000, pp. S10-5.
- [34] F. Miskelly, "Electronic tracking of patients with dementia and wandering using mobile phone technology," *Age and ageing*, vol. 34, 2005, pp. 497-499.
- [35] A. Marco, R. Casas, J. Falco, H. Gracia, J. Artigas, and A. Roy, "Location-based services for elderly and disabled people," *Computer Communications*, vol. 31, 2008, pp. 1055-1066.

- [36] C.-C. Lin, M.-J. Chiu, C.-C. Hsiao, R.-G. Lee, and Y.-S. Tsai, "Wireless Health Care Service System for Elderly With Dementia," *IEEE Transactions on Information Technology in Biomedicine*, vol. 10, Oct. 2006, pp. 696-704.
- [37] J. Loh, T. Schietecat, T.F. Kwok, L. Lindeboom, and P. Joore, *Technology applied to address difficulties of Alzheimer patients and their partners*, New York, New York, USA: ACM Press, 2004.
- [38] A. Sixsmith, N. Hine, I. Neild, N. Clarke, S. Brown, and P. Garner, "Monitoring the Well-being of Older People," *Topics in Geriatric Rehabilitation*, vol. 23, 2007.
- [39] M.D. Mulvenna, C.D. Nugent, F. Moelaert, D. Craig, R.-M. Dröes, and J.E. Bengtsson, *Supporting People with Dementia Using Pervasive Health Technologies*, London: Springer London, 2010.
- [40] C. Nugent, M. Mulvenna, F. Moelaert, B. Bergvall-Kåreborn, F. Meiland, D. Craig, R. Davies, A. Reinersmann, M. Hettinga, A.-L. Andersson, R.-M. Dröes, and J.E. Bengtsson, "Home based assistive technologies for people with mild dementia," *Pervasive Computing for Quality of Life Enhancement*, vol. 45, Jun. 2007, pp. 63-69.
- [41] W.-Y. Chung, S. Bhardwaj, A. Punvar, D.-S. Lee, and R. Myllyläe, "A fusion health monitoring using ECG and accelerometer sensors for elderly persons at home.," *Conference proceedings : ... Annual International Conference of the IEEE Engineering in Medicine and Biology Society. IEEE Engineering in Medicine and Biology Society. Conference*, vol. 2007, Jan. 2007, pp. 3818-21.
- [42] S. Herman and L.M. Koran, "In vivo measurement of obsessive-compulsive disorder symptoms using palmtop computers," *Computers in Human Behavior*, vol. 14, 1998, pp. 449-462.
- [43] M.G. Newman, J. Kenardy, S. Herman, and C.B. Taylor, "Comparison of palmtop-computer-assisted brief cognitive-behavioral treatment to cognitive-behavioral treatment for panic disorder.," *Journal of consulting and clinical psychology*, vol. 65, Feb. 1997, pp. 178-83.
- [44] W.T. Roth, "Physiological markers for anxiety: panic disorder and phobias.," *International journal of psychophysiology : official journal of the International Organization of Psychophysiology*, vol. 58, 2005, pp. 190-8.
- [45] K.M. Putnam and L.B. McSweeney, "Depressive symptoms and baseline prefrontal EEG alpha activity: a study utilizing Ecological Momentary Assessment.," *Biological psychology*, vol. 77, Feb. 2008, pp. 237-40.
- [46] E. Henje Blom, E. Olsson, E. Serlachius, M. Ericson, and M. Ingvar, "Heart rate variability (HRV) in adolescent females with anxiety disorders and major depressive disorder," *Acta paediatrica*, vol. 99, 2010, pp. 604-611.

- [47] T. Shinba, N. Kariya, Y. Matsui, N. Ozawa, Y. Matsuda, and K.-I. Yamamoto, "Decrease in heart rate variability response to task is related to anxiety and depressiveness in normal subjects.," *Psychiatry and clinical neurosciences*, vol. 62, Oct. 2008, pp. 603-9.
- [48] J.M. Gorman and R.P. Sloan, "Heart rate variability in depressive and anxiety disorders.," *American Heart Journal*, vol. 140, 2000, pp. 77-83.
- [49] A. Schwerdtfeger and P. Friedrich-Mai, "Social interaction moderates the relationship between depressive mood and heart rate variability: evidence from an ambulatory monitoring study," *Health psychology : official journal of the Division of Health Psychology, American Psychological Association*, vol. 28, Jul. 2009, pp. 501-9.
- [50] A.M. Boonstra, J.J.S. Kooij, J. Oosterlaan, J.A. Sergeant, J.K. Buitelaar, and E.J.W. Van Someren, "Hyperactive night and day? Actigraphy studies in adult ADHD: a baseline comparison and the effect of methylphenidate.," *Sleep*, vol. 30, Apr. 2007, pp. 433-42.
- [51] U.W. Ebner-Priemer, S.S. Welch, P. Grossman, T. Reisch, M.M. Linehan, and M. Bohus, "Psychophysiological ambulatory assessment of affective dysregulation in borderline personality disorder.," *Psychiatry research*, vol. 150, Apr. 2007, pp. 265-75.
- [52] V. Rapcan, S. D'Arcy, S. Yeap, N. Afzal, J. Thakore, and R.B. Reilly, "Acoustic and temporal analysis of speech: A potential biomarker for schizophrenia.," *Medical engineering & physics*, vol. 32, Nov. 2010, pp. 1074-9.
- [53] S.N. Ghaemi, *Mood disorders : a practical guide / S. Nassir Ghaemi.*, Lippincott Williams & Wilkins., 2008.
- [54] R. Morriss, "The early warning symptom intervention for patients with bipolar affective disorder," *Advances in Psychiatric Treatment*, vol. 10, 2004, pp. 18-26.
- [55] M.R. Basco, *The bipolar workbook : tools for controlling your mood swings / Monica Ramirez Basco.*, Guilford Press., 2006.
- [56] N. Andreasen, "Bipolar affective disorder and creativity: Implications and clinical management," *Comprehensive Psychiatry*, vol. 29, Jun. 1988, pp. 207-217.
- [57] C.M. Santosa, C.M. Strong, C. Nowakowska, P.W. Wang, C.M. Rennie, and T.A. Ketter, "Enhanced creativity in bipolar disorder patients: a controlled study.," *Journal of affective disorders*, vol. 100, Jun. 2007, pp. 31-9.
- [58] P.C. Whybrow, P. Grof, L. Gyulai, N. Rasgon, T. Glenn, and M. Bauer, "The electronic assessment of the longitudinal course of bipolar disorder: the ChronoRecord software.," *Pharmacopsychiatry*, vol. 36 Suppl 3, Nov. 2003, pp. S244-9.

- [59] M. Bauer, T. Wilson, K. Neuhaus, J. Sasse, A. Pfennig, U. Lewitzka, P. Grof, T. Glenn, N. Rasgon, T. Bschor, and P.C. Whybrow, "Self-reporting software for bipolar disorder: Validation of ChronoRecord by patients with mania," *Psychiatry Research*, vol. 159, 2008, pp. 359-366.
- [60] J.M. Bopp, D.J. Miklowitz, G.M. Goodwin, W. Stevens, J.M. Rendell, and J.R. Geddes, "The longitudinal course of bipolar disorder as revealed through weekly text messaging: a feasibility study.," *Bipolar disorders*, vol. 12, May. 2010, pp. 327-34.
- [61] "PSYCHE project," <http://www.psyche-project.org/>, 2009.
- [62] R. Paradiso, A.M. Bianchi, K. Lau, and E.P. Scilingo, "PSYCHE: Personalised monitoring systems for care in mental health.," *Conference proceedings : ... Annual International Conference of the IEEE Engineering in Medicine and Biology Society. IEEE Engineering in Medicine and Biology Society. Conference*, vol. 1, Jan. 2010, pp. 3602-5.
- [63] O.M. Ibarra, "MONitoring, treAtment and pRediCtion of bipolar Disorder Episodes," <http://www.monarca-project.eu/>, 2010.
- [64] D. Tacconi, O. Mayora, P. Lukowicz, B. Arnrich, C. Setz, G. Troster, and C. Haring, "Activity and emotion recognition to support early diagnosis of psychiatric diseases," *2008 Second International Conference on Pervasive Computing Technologies for Healthcare*, IEEE, 2008, pp. 100-102.
- [65] A. Matic, A. Papliatseyeu, and S. Gabrielli, "Happy or Moody? Why so?," create-net.org, 2010.
- [66] C.J. James, J. Crowe, E. Magill, S.C. Brailsford, J. Amor, P. Prociow, J. Blum, and S. Mohiuddin, "Personalised Ambient Monitoring (PAM) of the mentally ill," *4th European Conference of the International Federation for Medical and Biological Engineering*, J. Sloten, P. Verdonck, M. Nyssen, and J. Hauelsen, eds., Berlin, Heidelberg: Springer Berlin Heidelberg, 2009, pp. 1010-1013.
- [67] C. Perris, "A study of bipolar (manic-depressive) and unipolar recurrent depressive psychoses. IV. A multidimensional study of personality traits.," *Acta psychiatrica Scandinavica. Supplementum*, vol. 194, Jan. 1966, pp. 68-82.
- [68] J. Angst, "The emerging epidemiology of hypomania and bipolar II disorder.," *Journal of affective disorders*, vol. 50, Sep. 1998, pp. 143-51.
- [69] S. Pini, V. de Queiroz, D. Pagnin, L. Pezawas, J. Angst, G.B. Cassano, and H.U. Wittchen, "Prevalence and burden of bipolar disorders in European countries," *European Neuropsychopharmacology*, vol. 15, 2005, pp. 425-434.
- [70] American Psychiatric Association, *DSM-IV: diagnostic and statistical manual of mental disorders*, American Psychiatric Association, 1994.

- [71] S.N. Ghaemi, G.S. Sachs, A. M. Chiou, A.K. Pandurangi, and F.K. Goodwin, "Is bipolar disorder still underdiagnosed? Are antidepressants overutilized?," *Journal of affective disorders*, vol. 52, 1999, pp. 135-144.
- [72] J. Cavanagh, A. Jackson, and J. Scott, "A systematic review of manic and depressive prodromes.," *Journal of Affective Disorders*, vol. 74, 2003, pp. 209-217.
- [73] P. Mackin and A.H. Young, "Rapid cycling bipolar disorder: historical overview and focus on emerging treatments.," *Bipolar disorders*, vol. 6, Dec. 2004, pp. 523-9.
- [74] K.G. Kramlinger and R.M. Post, "Ultra-rapid and ultradian cycling in bipolar affective illness.," *The British journal of psychiatry : the journal of mental science*, vol. 168, Mar. 1996, pp. 314-23.
- [75] G. Murray and A. Harvey, "Circadian rhythms and sleep in bipolar disorder.," *Bipolar Disorders*, vol. 12, 2010, pp. 459-472.
- [76] S.L. Johnson, "Life events in bipolar disorder: towards more specific models.," *Clinical psychology review*, vol. 25, Dec. 2005, pp. 1008-27.
- [77] S. Malkoff-Schwartz, E. Frank, B.P. Anderson, S.A. Hlastala, J.F. Luther, J.T. Sherrill, P.R. Houck, and D.J. Kupfer, "Social rhythm disruption and stressful life events in the onset of bipolar and unipolar episodes.," *Psychological medicine*, vol. 30, Sep. 2000, pp. 1005-16.
- [78] R.W. Lam, E.E. Michalak, and R.P. Swinson, *Assessment scales in depression, mania and anxiety / Raymond W. Lam, Erin E. Michalak, Richard P. Swinson.*, Taylor & Francis., 2005.
- [79] P.B. Mitchell, J.R. Ball, J.A. Best, B.M. Gould, G.S. Malhi, G.J. Riley, and I.G. Wilson, "The management of bipolar disorder in general practice," *Medical journal of Australia*, vol. 184, 2006, p. 566.
- [80] P.A. Prociow and J.A. Crowe, "Development of mobile psychiatry for bipolar disorder patients.," *Conference proceedings : Annual International Conference of the IEEE Engineering in Medicine and Biology Society. IEEE Engineering in Medicine and Biology Society. Conference*, vol. 1, Jan. 2010, pp. 5484-7.
- [81] A. Hac, *Wireless sensor network designs*, Chichester, West Sussex, England; Hoboken, NJ: J. Wiley, 2003.
- [82] B. Hofmann-Wellenhof, H. Lichtenegger, and J. Collins, *Global positioning system : theory and practice / B. Hofmann-Wellenhof, H. Lichtenegger, J. Collins.*, Springer., 2001.
- [83] J.H. Schiller and A. Voisard, *Location-based services*, San Francisco, CA: Morgan Kaufmann Publishers, 2004.

- [84] J. Rekimoto, T. Miyaki, and T. Ishizawa, "LifeTag: WiFi-based continuous location logging for life pattern analysis," *Lecture Notes in Computer Science*, vol. 4718, 2007, p. 35.
- [85] V. Otsason, A. Varshavsky, A. LaMarca, and E. De Lara, "Accurate gsm indoor localization," *UbiComp 2005*, vol. 3660, 2005, pp. 141-158.
- [86] C.V. Bouten, K.T. Koekkoek, M. Verduin, R. Kodde, and J.D. Janssen, "A triaxial accelerometer and portable data processing unit for the assessment of daily physical activity.," *IEEE transactions on bio-medical engineering*, vol. 44, Mar. 1997, pp. 136-47.
- [87] Analog Devices, "ADXL 330 Small Low Power 3-Axis iMEMS Accelerometer," <http://www.analog.com/>, 2006.
- [88] J.M. Eagles, "The relationship between mood and daily hours of sunlight in rapid cycling bipolar illness.," *Biological Psychiatry*, vol. 36, 1994, pp. 422-424.
- [89] R.N. Golden, B.N. Gaynes, R.D. Ekstrom, R.M. Hamer, F.M. Jacobsen, T. Suppes, K.L. Wisner, and C.B. Nemeroff, "The efficacy of light therapy in the treatment of mood disorders: a review and meta-analysis of the evidence.," *The American Journal of Psychiatry*, vol. 162, 2005, pp. 656-662.
- [90] E. Alexandre, L. Cuadra, L. Alvarez, and M. Rosa-Zurera, "NN-based automatic sound classifier for digital hearing aids," *2007 IEEE International Symposium on Intelligent Signal Processing*, IEEE, 2007, pp. 1-6.
- [91] L. Lie, Z. Hong-Jiang, and J. Hao, "Content analysis for audio classification and segmentation," *IEEE Transactions on Speech and Audio Processing*, vol. 10, Oct. 2002, pp. 504-516.
- [92] Flexipanel, "Toothpick PIC with integral Bluetooth," <http://www.flexipanel.com/>, 2006.
- [93] D.J. Cook and S.K. Das, "S.: How smart are our environments? An updated look at the state of the art," *Pervasive and Mobile Computing*, vol. 3, 2007, pp. 53-73.
- [94] A.S. Crandall and D. Cook, "Attributing events to individuals in multi-inhabitant environments," *IET 4th International Conference on Intelligent Environments*, 2008, pp. 1-8.
- [95] R.J. Orr and G.D. Abowd, "The smart floor," *CHI '00 extended abstracts on Human factors in computing systems - CHI '00*, New York, New York, USA: ACM Press, 2000, p. 275.

- [96] J. Amor and C.J. James, "Personalised ambient monitoring: wireless cameras for activity detection," *5th IEEE EMBS UK & Republic of Ireland Postgraduate Conference on Biomedical Engineering and Medical Physics*, vol. 1, 2009, pp. 14-16.
- [97] A.G. Harvey, "Reviews and Overviews Sleep and Circadian Rhythms in Bipolar Disorder," *American Journal of Psychiatry*, vol. 165, 2008, pp. 820-829.
- [98] J.D. Amor and C.J. James, "Personalized Ambient Monitoring: Accelerometry for Activity Level Classification," *4th European Conference of the International Federation for Medical and Biological Engineering*, J. Sloten, P. Verdonck, M. Nyssen, and J. Haueisen, eds., Berlin, Heidelberg: Springer Berlin Heidelberg, 2009, pp. 866-870.
- [99] A. Ghosal, R. Chakraborty, R. Chakraborty, S. Haty, B.C. Dhara, and S.K. Saha, "Speech/Music Classification Using Occurrence Pattern of ZCR and STE," *2009 Third International Symposium on Intelligent Information Technology Application*, Nov. 2009, pp. 435-438.
- [100] W.W. Tryon and R. Williams, "Fully Proportional Actigraphy: A New Instrument," *Behavior Research Methods*, vol. 28, Jan. 2003, pp. 392-403.
- [101] Z. Liu, Y. Wang, and T. Chen, "Audio feature extraction and analysis for scene segmentation and classification," *Journal of VLSI Signal Processing Systems for Signal Image and Video Technology*, vol. 20, 1998, pp. 61-79.
- [102] E. Guaus and E. Batlle, "A non-linear rhythm-based style classification for Broadcast Speech-Music Discrimination," *116th. AES Convention*, Berlin, Germany: 2004, pp. 1-8.
- [103] L.G.-P.R.R.-Z.M. Alexandre Enrique; Cuadra-Rodríguez, "Application of Fisher Linear Discriminant Analysis to Speech/Music Classification," *Audio Engineering Society Convention 120*, 2006.
- [104] J. Saunders, "Real-time discrimination of broadcast speech/music," *1996 IEEE International Conference on Acoustics, Speech, and Signal Processing Conference Proceedings*, IEEE, 1996, pp. 993-996.
- [105] American Academy of Sleep Medicine., *The AASM manual for the scoring of sleep and associated events : rules, terminology and technical specifications*, Westchester, IL: American Academy of Sleep Medicine, 2007.
- [106] J.D. Kales, A. Kales, C.R. Soldatos, A.B. Caldwell, D.S. Charney, and E.D. Martin, "Night terrors. Clinical characteristics and personality patterns.," *Archives of general psychiatry*, vol. 37, Dec. 1980, pp. 1413-7.

- [107] P. Prociow and J.A. Crowe, "Sensors enhancing self-monitoring for people with bipolar disorder," *5th IEEE EMBS UK & Republic of Ireland Postgraduate Conference on Biomedical Engineering and Medical Physics*, vol. 1, 2009, pp. 50-52.
- [108] P.A. Prociow, J.A. Crowe, C.J. James, E. Magill, S.C. Brailsford, J. Amor, J. Blum, and S. Mohiuddin, "Personalised Ambient Monitoring (PAM) for People with Bipolar Disorder," *Global Telemedicine and eHealth Updates: Knowledge Resources*, vol. 2, 2009, pp. 532-534.
- [109] P.A. Prociow, K. Wac, and J.A. Crowe, "Design of a Wearable System for Personalized Monitoring and Therapeutic Interventions in Bipolar Disorder," *Therapeutic Strategies A Challenge for User Involvement in Design Workshop in conjunction with NORDICHI 2010*, 2010, pp. 46-50.
- [110] A. Varshavsky, "Are GSM Phones THE Solution for Localization?," *Seventh IEEE Workshop on Mobile Computing Systems Applications WMCSA06*, IEEE, 2006, pp. 34-42.
- [111] ABI Research, "Nearly 2.4 Billion Units of Bluetooth-Enabled Equipment to Ship in 2013," <http://www.abiresearch.com>, 2008.
- [112] N. Eagle, A.S. Pentland, and D. Lazer, "Inferring friendship network structure by using mobile phone data.," *Proceedings of the National Academy of Sciences of the United States of America*, vol. 106, Sep. 2009, pp. 15274-8.
- [113] V. Kostakos, "An empirical study of spatial and transpatial social networks using Bluetooth and Facebook," <http://arxiv.org/>, 2009.
- [114] R. José, N. Otero, S. Izadi, and R. Harper, "Instant Places: Using Bluetooth for Situated Interaction in Public Displays," *IEEE Pervasive Computing*, vol. 7, 2008, pp. 52-57.
- [115] V. Kostakos, E. O'Neill, and A. Shahi, "Building common ground for face to face interactions by sharing mobile device context," *LOCA 2006 LNCS*, 2010, pp. 222 - 238.
- [116] C. Zhou, N. Bhatnagar, S. Shekhar, and L. Terveen, "Mining Personally Important Places from GPS Tracks," *23rd IEEE International Conference on Data Engineering, 2007*, IEEE Computer Society, 2007, pp. 517-526.
- [117] P. Nurmi and J. Koolwaaij, "Identifying meaningful locations," *Third Annual International Conference on Mobile and Ubiquitous Systems Networking Services*, Ieee, 2006, pp. 1-8.
- [118] P. Berkhin, "A survey of clustering data mining techniques," *Grouping Multidimensional Data: Recent Advances in Clustering*, 2006, pp. 25-71.

- [119] C. Zhou, S. Shekhar, and L. Terveen, "Discovering personal paths from sparse GPS traces," *1st International Workshop on Data Mining in conjunction with 8th Joint Conference on Information Sciences July*, Citeseer, 2005, pp. 3-6.
- [120] G. Agamennoni, J. Nieto, and E. Nebot, "Mining GPS Data for Extracting Significant Places," *Proceedings of the IEEE International Conference on Robotics and Automation (2009)*, 2009, pp. 855-862.
- [121] M. Ester, H.P. Kriegel, J. Sander, and X. Xu, "A density-based algorithm for discovering clusters in large spatial databases with noise," *Proceedings of the 2nd International Conference on Knowledge Discovery and Data mining*, Portland: AAAI Press, 1996, p. 226–231.
- [122] Ofcom, "Mobile phone base station database," <http://www.sitefinder.ofcom.org.uk/search>, 2010.
- [123] J. Koolwaaij, "Mapping the GSM landscape," *Annual Conference on Scalable Vector Graphics (SVG)*, Enschede: 2005, pp. 1-8.
- [124] K. Michael, A. McNamee, and M. Michael, "The Emerging Ethics of Humancentric GPS Tracking and Monitoring," *ICMB '06. International Conference on Mobile Business*, 2006, pp. 34-34.
- [125] A.A. Adams and I. Brown, "The ethical challenges of ubiquitous healthcare," *International Review of Information Ethics*, vol. 8, 2007, pp. 53-60.