

Awad, Sherif (2010) Metabolic and cellular effects of carbohydrate-based preconditioning drinks. PhD thesis, University of Nottingham.

Access from the University of Nottingham repository:

http://eprints.nottingham.ac.uk/11572/2/Sherif_Awad_no_sig.pdf

Copyright and reuse:

The Nottingham ePrints service makes this work by researchers of the University of Nottingham available open access under the following conditions.

- Copyright and all moral rights to the version of the paper presented here belong to the individual author(s) and/or other copyright owners.
- To the extent reasonable and practicable the material made available in Nottingham ePrints has been checked for eligibility before being made available.
- Copies of full items can be used for personal research or study, educational, or not-for-profit purposes without prior permission or charge provided that the authors, title and full bibliographic details are credited, a hyperlink and/or URL is given for the original metadata page and the content is not changed in any way.
- Quotations or similar reproductions must be sufficiently acknowledged.

Please see our full end user licence at:

http://eprints.nottingham.ac.uk/end_user_agreement.pdf

A note on versions:

The version presented here may differ from the published version or from the version of record. If you wish to cite this item you are advised to consult the publisher's version. Please see the repository url above for details on accessing the published version and note that access may require a subscription.

For more information, please contact eprints@nottingham.ac.uk

**Metabolic and cellular effects of carbohydrate-based
preconditioning drinks**

Sherif Awad, BSc, MBChB (Hons), MRCS

Thesis submitted to the University of Nottingham

for the degree of Doctor of Philosophy

DECEMBER 2010

Abstract

This thesis investigates the metabolic and cellular effects of carbohydrate-based preconditioning drinks in humans. Previous studies have demonstrated that preoperative carbohydrate loading, as opposed to overnight fasting, attenuated the development of postoperative insulin resistance by up to 50% and led to clinical benefits. Preconditioning with carbohydrate-based drinks was incorporated into enhanced recovery after surgery programs. The latter included interventions that aimed to minimise 'metabolic-stress' and hasten recovery after major surgery. However, the cellular mechanisms underlying the adverse effects of preoperative fasting and the beneficial effects of preconditioning with carbohydrate-based drinks were hitherto unknown. In healthy volunteers, short-term fasting (up to 24 hours) reduced liver volume, depleted liver glycogen (-50%) and lipid reserves, and increased intramyocellular lipid concentrations (+23%), as measured by magnetic resonance spectroscopy. Changes in liver glycogen were partially reversed following ingestion of a carbohydrate-based drink that also contained glutamine and antioxidants (ONS, Fresenius Kabi, Germany). Fasting also led to significantly decreased blood mononuclear cell mitochondrial complex activity. In patients undergoing laparoscopic cholecystectomy, preoperative conditioning with ONS, compared to ingestion of a placebo-drink, significantly increased intraoperative liver glycogen by 50%, increased intraoperative plasma glutamine and antioxidant concentrations, led to lower expression of skeletal muscle pyruvate dehydrogenase kinase 4 mRNA and protein expression, and finally, reduced cellular oxidative stress, as indicated by a 1.5-fold lower expression of metallothionein-1A in the ONS group. Ingestion

of ONS led to markedly differing hormonal and metabolic responses compared to those following a clear carbohydrate drink (preOp[®], Nutricia Clinical Care, UK), with 'blunted' postprandial glucose and insulin responses following ONS. Supplementing preOp[®] with glutamine 'blunted' postprandial insulin and glucose responses but this was not due to differences in glucagon-like peptide-1 concentrations. Finally, the gastric emptying of these drinks was more dependent on carbohydrate content than macronutrient composition or osmolality.

Acknowledgements

بِسْمِ اللَّهِ الرَّحْمَنِ الرَّحِيمِ

The work undertaken in this thesis would not have been possible without the collaborative and supportive effort of a number of individuals to whom I am deeply indebted:

- I had the privilege of being guided, mentored, encouraged and always supported by my supervisor Mr Dileep N Lobo whose drive for success and innovative thinking has been a great inspiration for me.
- To Professor Ian A Macdonald, for allowing me access to his expertise, first-class research team and providing invaluable critical appraisal of my studies and manuscripts.
- To Professor Brian J Rowlands, for having the belief in me and providing me with the opportunity and unwavering support to fulfil my research aspirations.
- To Tim and Despina Constantin, for taking the time to train, guide and assist me through the metabolic and molecular assays.
- To Liz Simpson, Elaine, Julie Littlewood and Jane Krause, whose company and help was invaluable during studies undertaken in the Sir David Greenfield Human Physiology Laboratory.

- To Ben Wall, Craig Porter, Ryan Atkins, Francis Stephens, Sally Cordon and Karen Swift, for their assistance and training in performing the metabolic assays.
- To Luca Marciani and Mary Stephenson, for dedicating their weekends and free time to help me develop and complete the magnetic resonance spectroscopy study on schedule.
- To Professors Robin C Spiller, Penny A Gowland, Peter G Morris, Kenneth CH Fearon and Alan C Perkins for their help in designing and supporting my studies.
- To Elaine Blackshaw, for her guidance, support and expertise.
- To Kate Shepherd, Chandan Verma and Debbie Bush, for their help in guiding me through the systems and processes behind research.
- To all the volunteers and patients who have donated their effort, time and tissue in the hope of furthering science.
- To the funders of these studies, without the support of whom none of this work would have been possible: The Royal College of Surgeons of England Research Fellowship Scheme, the Doris Mary Sheppard Legacy, the Rosetrees Trust, the Mason Medical Research Foundation, the

Enhanced Recovery After Surgery Group and Fresenius Kabi.

- To my sisters (Dina and Rania) and extended family members, for putting up with my antisocial hours and for all your encouraging and supportive words.
- To my parents Dr Mohamed Abdel-All and Dr Shamah Elsaidy, thank you for your love, effort and personal sacrifice; without which I would not be where I am today.

Finally, to my beloved wife Mona...thank you for your endless encouragement, patience, support, tolerance and sacrifice. Your love has kept me going.

Table of contents

Abstract	ii
Acknowledgements	v
Table of contents	ix
Declaration	xvi
Presentations arising from this thesis	xviii
Publications arising from this thesis	xxii
Prizes awarded to work originating from this thesis	xxvi
List of abbreviations	xxviii
Chapter 1: Introduction	1
1.1 Search strategy	2
1.2 Metabolic regulation and the development of insulin resistance	
during fasting and surgery	3
<i>1.2.1 Body fuel reserves</i>	6
<i>1.2.2 Energy metabolism interactions</i>	7
<i>1.2.3 Metabolic effects of short-term fasting</i>	8
<i>1.2.4 Perioperative reduction in insulin sensitivity</i>	9
<i>1.2.5 Cellular pathways involved in the development of perioperative insulin resistance</i>	15
1.3 Preoperative fasting and carbohydrate loading	19
<i>1.3.1 Preoperative fasting: History and current guidelines</i>	19
<i>1.3.2 Animal studies on the metabolic effects of preoperative fasting</i>	21
<i>1.3.3 Human studies on the metabolic effects of preoperative fasting</i>	26

1.3.4 Preoperative carbohydrate loading versus fasting	27
1.3.5 Perioperative glutamine and antioxidant supplementation	44
1.4 Mitochondrial function	46
1.4.1 Mitochondrial function in health	47
1.4.2 Oxidative stress	48
1.4.3 Mitochondrial dysfunction and insulin resistance	49
1.4.4 Mitochondrial function in fasting	52
1.4.5 Perioperative mitochondrial dysfunction	58
1.4.6 Effects of carbohydrate loading on mitochondrial function	58
1.5 Conclusions	59
Chapter 2: Hypotheses	61
Chapter 3: Common methods	65
3.1 Approvals from regulatory bodies	66
3.2 Eligibility and exclusion criteria for healthy volunteer studies	66
3.3 Randomisation and blinding	67
3.4 Collection of blood samples	67
3.5 Analysis of blood samples	68
3.5.1 Insulin assays	69
3.5.2 Glucagon assays	69
3.5.3 Non-esterified fatty acid assays	69
3.5.4 β -hydroxybutyrate assays	70
3.5.5 Glucagon-like peptide 1 assay	70

3.5.6 <i>Vitamin assays</i>	70
3.5.7 <i>Trace element assays</i>	71
3.5.8 <i>Amino acid assays</i>	71
3.6 Protein concentrations	71
3.7 Composition of study drinks	72
3.8 Statistical analyses	74
3.9 Funding for studies	75
Chapter 4: The effects of fasting and refeeding with a ‘metabolic preconditioning’ drink on substrate reserves and mononuclear cell mitochondrial function	76
4.1 Aims	77
4.2 Methods	77
4.2.1 <i>Interventions</i>	77
4.2.2 <i>Standardised meal and ONS</i>	78
4.2.3 <i>Study protocol</i>	78
4.2.4 <i>Magnetic resonance techniques</i>	80
4.2.5 <i>Sampling of blood samples</i>	85
4.2.6 <i>Preparation of mononuclear cells</i>	85
4.2.7 <i>Enzyme assays</i>	89
4.2.7.1 <i>Protein concentrations</i>	89
4.2.7.2 <i>Mitochondrial membrane complex activities</i>	89
4.2.8 <i>Statistical analyses</i>	93
4.3 Results	94
4.3.1 <i>Standardised meal</i>	94
4.3.2 <i>Blood assays</i>	94
4.3.3 <i>Liver volume, glycogen and lipid</i>	97

4.3.4 <i>Muscle glycogen and lipid</i>	100
4.3.5 <i>Mononuclear cell mitochondrial membrane complex activity</i>	101
4.4 Discussion	102
Chapter 5: Cellular mechanisms underlying the protective effects of preoperative feeding: a randomised study investigating muscle and liver glycogen concentrations mitochondrial function, gene and protein expression	106
5.1 Aims	107
5.2 Methods	107
5.2.1 <i>Study design</i>	107
5.2.2 <i>Interventions</i>	108
5.2.3 <i>Randomisation</i>	110
5.2.4 <i>Blood samples</i>	111
5.2.5 <i>Mitochondrial function</i>	111
5.2.6 <i>ATP, phosphocreatine and glycogen measurements</i>	112
5.2.7 <i>Muscle glutamine concentrations</i>	112
5.2.8 <i>Quantitative RT-PCR</i>	112
5.2.9 <i>Western blotting</i>	113
5.2.10 <i>Study outcomes</i>	114
5.3 Results	116
5.3.1 <i>Metabolic assays</i>	117
5.3.2 <i>Glycogen and muscle glutamine concentrations</i>	120
5.3.3 <i>Mitochondrial function</i>	121
5.3.4 <i>Gene and protein expression</i>	122
5.4 Discussion	125

Chapter 6: A randomised crossover study of the metabolic and hormonal responses following ingestion of two ‘preoperative’ conditioning drinks	130
6.1 Aims	131
6.2 Methods	131
<i>6.2.1 Interventions</i>	131
<i>6.2.2 Blood samples</i>	132
<i>6.2.3 Study outcomes and statistics</i>	133
6.3 Results	134
<i>6.3.1 Glucose, insulin and glucagon concentrations</i>	134
<i>6.3.2 NEFA and OHB concentrations</i>	138
<i>6.3.3 Glutamine concentrations</i>	141
6.4 Discussion	142
Chapter 7: A randomised crossover study on the effects of glutamine and lipid on the gastric emptying time of a preoperative carbohydrate drink	145
7.1 Aims	146
7.2 Methods	147
<i>7.2.1 Interventions</i>	147
<i>7.2.2 Randomisation</i>	147
<i>7.2.3 Study drinks</i>	148
<i>7.2.4 Blood samples and metabolic assays</i>	153
<i>7.2.5 Scintigraphic acquisitions and analyses</i>	154
<i>7.2.6 Study outcomes and statistical analyses</i>	154
7.3 Results	156
<i>7.3.1 Gastric emptying times</i>	156

7.3.2 <i>Glucose, insulin and GLP-1 concentrations</i>	158
7.4 Discussion	162
Chapter 8: Critique of thesis	167
Chapter 9: Future directions	176
Bibliography	179
Appendix A	209

Declaration

Except where acknowledged in the acknowledgements and text, I declare that this dissertation is my own work and is based on research that was undertaken by me in the Division of Gastrointestinal Surgery and the School of Biomedical Sciences, University of Nottingham from 3 October 2007 to 2 October 2009.

Sherif Awad

Date: 8th October 2010

Presentations arising from this thesis

Platform presentations

1) Awad S, Stephenson MC, Marciani L, Placidi E, Constantin-Teodosiu D, Gowland PA, Spiller RC, Fearon KCH, Morris PG, Macdonald IA, Lobo DN. The effects of short-term starvation and refeeding with a metabolic preconditioning oral nutritional supplement on substrate reserves and mitochondrial function: potential mechanisms by which preoperative feeding improves insulin sensitivity. Presented at the Moynihan Prize session of the International Congress of the Association of Surgeons of Great Britain and Ireland – Glasgow, May 09.

2) Awad S, Constantin-Teodosiu D, Rowlands BJ, Fearon KCH, Macdonald IA, Lobo DN. Investigating the safety and metabolic effects of a new 'metabolic preoperative preconditioning' drink in patients undergoing gastrointestinal surgery: a randomised placebo controlled double-blind study (NCT00662376). Presented at the Annual Congress of the European Society of Clinical Nutrition and Metabolism (ESPEN) – Vienna, August 2009.

3) Awad S, Constantin-Teodosiu D, Fearon KCH, Macdonald IA, Lobo DN. Cellular mechanisms underlying the protective effects of preoperative feeding: a randomised study investigating muscle and liver glycogen content, mitochondrial function and gene expression. Presented at the Moynihan Prize session of the International Congress of the Association of Surgeons of Great Britain and Ireland – Liverpool, April 2010.

4) Awad S, Fearon KCH, Macdonald IA, Lobo DN. Investigating the dynamic metabolic and hormonal responses following ingestion of two 'preoperative' conditioning drinks: a randomised double-blind crossover study. Presented at the International Congress of the Association of Surgeons of Great Britain and Ireland – Liverpool, April 2010.

Poster presentations

1) Awad S, Stephenson MC, Marciani L, Placidi E, Constantin-Teodosiu D, Gowland PA, Spiller RC, Fearon KCH, Morris PG, Macdonald IA, Lobo DN. The effects of fasting and refeeding with a 'metabolic preconditioning' drink on substrate reserves and mitochondrial function: potential mechanisms by which preoperative feeding improves insulin sensitivity. Presented at the Annual Congress of the European Society of Clinical Nutrition and Metabolism (ESPEN) – Vienna, August 2009.

2) Awad S, Constantin-Teodosiu D, Teodosiu D, Fearon KCH, Rowlands BJ, Macdonald IA, Lobo DN. Cellular mechanisms underlying the protective effects of preoperative carbohydrate loading: a randomised study investigating mitochondrial function, gene and protein expression (NCT00662376). Presented at the Annual Congress of the European Society of Clinical Nutrition and Metabolism (ESPEN) – Nice, September 2010.

3) Awad S, Fearon KCH, Macdonald IA, Lobo DN. A randomised study of the metabolic and hormonal responses following two preoperative conditioning drinks (NCT00909701). Presented at the Annual Congress of the European Society of Clinical Nutrition and Metabolism (ESPEN) – Nice, September 2010.

4) Awad S, Blackshaw PE, Wright JW, Macdonald IA, Perkins AC, Lobo DN. The effects of glutamine and lipid on the gastric emptying times and metabolic responses of a preoperative carbohydrate drink: a randomised crossover study (NCT00943020). Presented at the Annual Congress of the European Society of Clinical Nutrition and Metabolism (ESPEN) – Nice, September 2010.

Publications arising from this thesis

Published papers

- 1) Awad S, Constantin-Teodosiu D, Macdonald IA, Lobo DN. Short-term starvation and mitochondrial dysfunction - a possible mechanism leading to postoperative insulin resistance. *Clinical Nutrition* 2009; 28: 497-509.
- 2) Awad S, Stephenson MC, Placidi E, Marciani L, Constantin-Teodosiu D, Gowland PA, Spiller RC, Fearon KCH, Morris PG, Macdonald IA, Lobo DN. The effects of fasting and refeeding with a 'metabolic preconditioning' drink on substrate reserves and mononuclear cell mitochondrial function. *Clinical Nutrition* 2010; 29(4): 538-544.
- 3) Awad S, Constantin-Teodosiu D, Constantin D, Rowlands BJ, Fearon KCH, Macdonald IA, Lobo DN. Cellular mechanisms underlying the protective effects of preoperative feeding: a randomized study investigating muscle and liver glycogen content, mitochondrial function, gene and protein expression. *Annals of Surgery* 2010; 252(2):247-253.
- 4) Awad S, Fearon KCH, Macdonald IA, Lobo DN. A randomized crossover study of the metabolic and hormonal responses following two preoperative conditioning drinks. *Nutrition*. *In press* DOI:10.1016/j.nut.2010.08.025.
- 5) Awad S, Blackshaw PE, Wright JW, Macdonald IA, Perkins AC, Lobo DN. A randomized crossover study on the effects of glutamine and lipid on gastric

emptying time of a preoperative carbohydrate drink. *Clinical Nutrition*. *In press*
DOI: 10.1016/j.clnu.2010.09.008

Published abstracts

1a) Awad S, Stephenson MC, Marciani L, Placidi E, Constantin-Teodosiu D, Gowland PA, Spiller RC, Fearon KCH, Morris PG, Macdonald IA, Lobo DN. The effects of starvation and refeeding using a metabolic preconditioning drink on substrate reserves and mitochondrial function. *British Journal of Surgery* 2009; 96 (S4): 2

1b) Awad S, Stephenson MC, Marciani L, Placidi E, Constantin-Teodosiu D, Gowland PA, Spiller RC, Fearon KCH, Morris PG, Macdonald IA, Lobo DN. The effects of fasting and refeeding using a 'metabolic preconditioning' drink on substrate reserves and mitochondrial function: potential mechanisms by which preoperative feeding improves insulin sensitivity. *Clinical Nutrition Supplements* 2009; 4(S2): 69

2) Awad S, Constantin-Teodosiu D, Rowlands BJ, Fearon KCH, Macdonald IA, Lobo DN. Investigating the safety and metabolic effects of a new 'metabolic preconditioning' drink in patients undergoing gastrointestinal surgery: A randomised placebo controlled double-blind study (NCT00662376). *Clinical Nutrition Supplements* 2009; 4(S2): 19-20

3a) Awad S, Constantin-Teodosiu D, Fearon KCH, Macdonald IA, Lobo DN. Cellular mechanisms underlying the protective effects of preoperative feeding: a randomized study investigating muscle and liver glycogen content, mitochondrial function and gene expression. *British Journal of Surgery* 2010; 97(S2): 2

3b) Awad S, Constantin-Teodosiu D, Teodosiu D, Fearon KCH, Rowlands BJ, Macdonald IA, Lobo DN. Cellular mechanisms underlying the protective effects of preoperative carbohydrate loading: a randomised study investigating mitochondrial function, gene and protein expression (NCT00662376). *Clinical Nutrition Supplements* 2010; 5(S2): 113-114

4a) Awad S, Fearon KCH, Macdonald IA, Lobo DN. Investigating the dynamic metabolic and hormonal responses following ingestion of two 'preoperative' conditioning drinks: a randomized double-blind crossover study. *British Journal of Surgery* 2010; 97(S2): 31

4b) Awad S, Fearon KCH, Macdonald IA, Lobo DN. A randomised study of the metabolic and hormonal responses following two preoperative conditioning drinks (NCT00909701). *Clinical Nutrition Supplements* 2010; 5(S2): 126

5) Awad S, Blackshaw PE, Wright JW, Macdonald IA, Perkins AC, Lobo DN. The effects of glutamine and lipid on the gastric emptying times and metabolic responses of a preoperative carbohydrate drink: a randomised crossover study (NCT00943020). *Clinical Nutrition Supplements* 2010; 5(S2): 126

Prizes awarded for work originating from this thesis

Short-listed for the Moynihan prize of the Association of Surgeons of Great Britain and Ireland International Congress 2009.

Winner of the European Society of Clinical Nutrition and Metabolism Young Investigator Travelling Fellowship 2009.

Winner of the Royal College of Surgeons of England Rosetrees Prize 2009.

Winner of the Moynihan prize of the Association of Surgeons of Great Britain and Ireland International Congress 2010.

Winner of Best Registrar Research Paper Prize by the Travelling Surgical Society UK Meeting – Nottingham 2010.

List of abbreviations

β -HAD - β -hydroxyacyl CoA dehydrogenase
BMI – body mass index
COX – carbohydrate oxidation
CRP – C-reactive protein
EMCL – extramyocellular lipid
ETC – electron transport chain
FOXO1 – forkhead transcription factor 1
FFA – free fatty acids
FBC – full blood count
GLP-1 – glucagon-like peptide 1
HPLC – high performance liquid chromatography
IMCL – intramyocellular lipid
IRS – insulin receptor substrate
KCN – potassium cyanide
MMC – mitochondrial membrane complex
MNC – mononuclear cell
MRS – magnetic resonance spectroscopy
Mt-1A – metallothionein-1A
NEFA – non-esterified fatty acids
OHB – β -hydroxybutyrate
PCr – phosphocreatine
PBMC – peripheral blood mononuclear cells
PDC – pyruvate dehydrogenase complex
PDK4 – pyruvate dehydrogenase kinase 4
PPAR α – peroxisome proliferator-activated receptors α
PPAR δ – peroxisome proliferator-activated receptors δ
TCA – tricarboxylic acid cycle
ROS – reactive oxygen species
U&E – Urea and electrolytes

Chapter 1

Introduction

Recent studies have demonstrated that preoperative fasting induces metabolic stress and leads to postoperative insulin resistance which results in hyperglycaemia. The latter may cause increased infective complications, morbidity and mortality. Measures aimed at decreasing perioperative insulin resistance, such as the avoidance of preoperative fasting by giving patients carbohydrate-based drinks up to 2 hours preoperatively, may lead to clinical benefits. However, the mechanisms that underlie the development of perioperative insulin resistance during fasting and its attenuation by preoperative conditioning with carbohydrate-based drinks are yet to be defined. Understanding these mechanisms would allow the optimisation and improvement of interventions designed to reduce insulin resistance. This Chapter reviews and discusses the adverse effects of short-term (up to 36 hours) fasting, the development of insulin resistance and its clinical significance, the evidence base that relates to preoperative carbohydrate loading and the mechanisms that may link mitochondrial dysfunction to the development of insulin resistance.

1.1 Search strategy

Searches of the Medline (Ovid, PubMed, Embase) and Science Citation Index databases, and the Google™ search engine were performed using the key words metabolic, stress, metabolism, hormones, insulin, insulin resistance, insulin sensitivity, starvation, fast, preoperative, postoperative, surgery, anaesthesia,

outcome, complication, carbohydrate, feed, load, mitochondria, oxidative stress and reactive oxygen species in various combinations with the Boolean operators AND, OR and NOT. Animal and human studies published in the last 30 years and key earlier articles were included. Articles published in languages other than English, those published only in abstract form and case reports were excluded. Key journals, textbooks on nutrition and metabolism, and the reference lists of key articles were also hand searched.

1.2 Metabolic regulation and the development of insulin resistance during fasting and surgery

The regulation of the body's energy reserves is crucial to survival and is brought about by metabolic pathways controlled by a number of hormones, the most important being insulin and glucagon (Table 1.1).

Table 1.1: Hormones involved in the metabolic regulation of the body's energy reserves (Frayn, 1999; Allison and Go, 2004).

Hormone	Metabolic effects
Insulin	<p>Carbohydrate metabolism: inhibits glycogenolysis, stimulates glycogenesis, inhibits gluconeogenesis, stimulates glycolysis, stimulates muscle and fat cellular glucose uptake</p> <p>Protein metabolism: decreases protein catabolism, increases amino acid uptake</p>

	<p>Fat metabolism: stimulates lipogenesis, stimulates uptake of fatty acids from plasma triacylglycerol into adipose tissue (via lipoprotein lipase), inhibits lipolysis (inhibition of hormone-sensitive lipase), inhibits fatty acid oxidation, inhibits ketogenesis</p> <p>Gene expression: control of genes involved in glucose metabolism and <i>de novo</i> lipogenesis</p>
Glucagon	<p>Carbohydrate metabolism: stimulates glycogenolysis, stimulates gluconeogenesis, inhibits glycolysis</p> <p>Protein metabolism: stimulates amino acid catabolism</p> <p>Fat metabolism: stimulates fatty acid oxidation, stimulates ketogenesis</p>
Glucocorticoids	<p>Carbohydrate metabolism: stimulate gluconeogenesis, inhibit muscle glucose uptake</p> <p>Protein metabolism: stimulate protein catabolism</p> <p>Fat metabolism: stimulate lipolysis</p>
Noradrenaline/ Adrenaline	<p>Carbohydrate metabolism: stimulate glycogenolysis</p> <p>Protein metabolism: stimulate amino acid catabolism</p> <p>Fat metabolism: stimulate lipolysis (via hormone-sensitive lipase)</p>
Thyroid hormones	<p>Modulate level of response of body to other hormones, in particular, regulate sensitivity of metabolic processes to catecholamines</p> <p>Protein metabolism: stimulate protein catabolism</p>
Growth hormone	<p>Carbohydrate metabolism: stimulates hepatic gluconeogenesis and glycogenolysis</p> <p>Protein metabolism: stimulates protein synthesis</p> <p>Fat metabolism: stimulates lipolysis</p>

Plasma glucose concentrations are primarily controlled by insulin and glucagon. On binding to its cell membrane receptor (Figure 1.1), insulin initiates a signal that permits the storage of energy within liver, muscle and adipose tissue (Krentz, 2002; Allison and Go, 2004). The facilitative glucose transporter (GLUT-4) is of importance in the regulation of the body's energy reserves by permitting the movement of glucose down a concentration gradient across cell membranes.

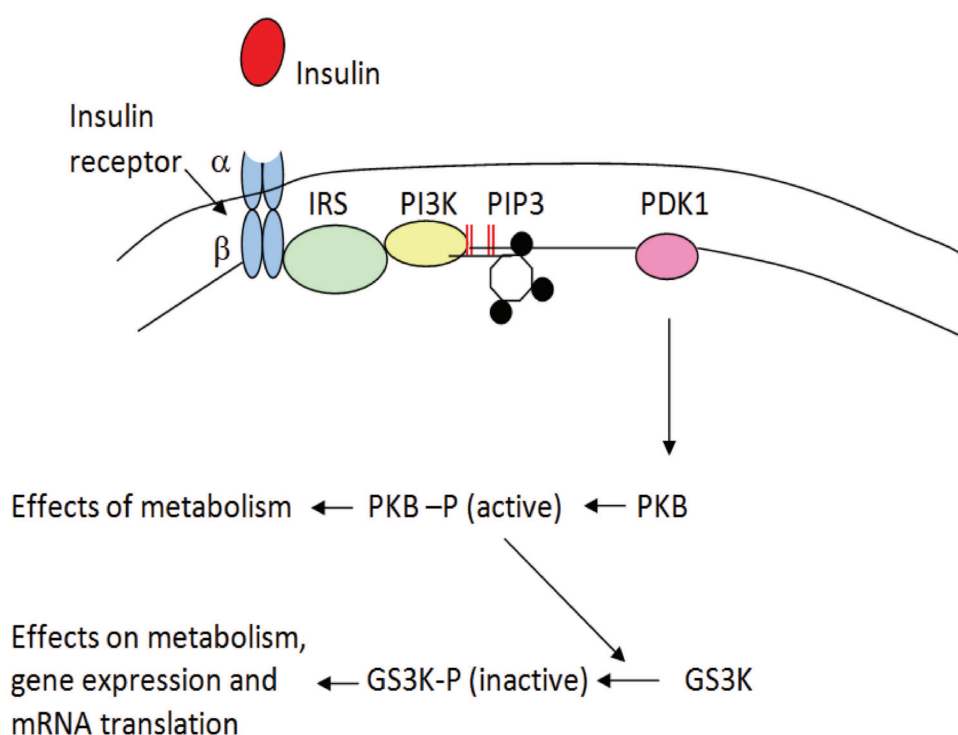

Figure 1.1: Signal transduction chain for the metabolic regulation by insulin. The insulin-receptor signalling involves two major pathways: the mitogen activated protein kinase (MAPK) pathway, which is mainly responsible for mitogenesis and cell growth and will not be considered further. The second is the phosphatidylinositol-3-kinase (PI3K) pathway which accounts for metabolic responses. Insulin binds to its receptor leading to autophosphorylation of tyrosine residues in the receptor protein. This leads to interaction with a family of proteins known as insulin receptor substrates (IRS), which themselves become phosphorylated and then interact with the enzyme PI3K. PI3K

generates phosphatidylinositol (3',4',5')-trisphosphate (PIP3) in the inner surface of the membrane, which acts through the enzyme 3'-phosphatidylinositol dependent kinase-1 (PDK1) to phosphorylate (and activate) protein kinase B (PKB, also known as Akt). Activated PKB leads to several cellular responses to insulin including inhibition of lipolysis, increased glucose transport, effects on DNA transcription, and phosphorylation and inactivation of glycogen synthase kinase 3 (GSK3). Inactivation of GSK3 also leads to multiple cellular effects including stimulation of glycogen synthesis, effects on gene expression and protein chain initiation (i.e. mRNA translation). Copyright © 2003 Blackwell. From *Metabolic Regulation A Human Perspective*, Frayn KN, 2nd Edition, 2003. Modified with permission from *Blackwell publishing*.

Following the binding of insulin to its receptor, the subsequent intracellular signal leads to the translocation of intracellular GLUT-4-rich vesicles to the cell membrane (Krentz, 2002). This increases the amount of GLUT-4 transporters available for glucose transport into the cell. By contrast, glucagon acts mainly on the liver to increase plasma glucose concentration. A fall in plasma glucose concentration will, therefore, lead to a decreased ratio of plasma insulin to glucagon, the net effect being elevation of blood glucose concentration.

1.2.1 Body fuel reserves

Carbohydrate is stored as glycogen with only skeletal muscle and the liver having sufficient glycogen reserves to fulfil bodily needs. Skeletal muscle comprises 40% of body weight and contains around 350-400 g of glycogen (15 g/kg muscle)

(Frayn, 1999). As muscle lacks the enzyme glucose-6-phosphatase, this store of glycogen cannot be released into the circulation as glucose. Instead, muscle utilises glycogen to release glucose precursors (lactate, pyruvate and/or alanine) that are used by the liver for gluconeogenesis (Frayn, 1999). The cycle whereby lactate, produced by anaerobic glycolysis in muscle, moves to the liver where it is converted to glucose, which returns to muscles and is converted back to lactate, is termed the Cori cycle. Liver glycogen reserves are more readily available in the form of glucose and play the major role of 'buffering' glucose concentrations. The liver glycogen content varies and is dependent on factors such as diet and exercise, but is typically around 50-120 g (50-80 g/kg liver).

1.2.2 Energy metabolism interactions

The post-absorptive state is typically represented by the situation after an overnight fast. Plasma glucose concentration is just under 5 mmol/L and the concentration of insulin is typically around 9 mIU/L. At this time, plasma concentrations of glucose and insulin are at the nadir of the 24-hour cycle and glucose enters the blood almost exclusively from the liver following both glycogenolysis and gluconeogenesis. Gluconeogenic substrates consist of lactate (from sources including muscle, erythrocytes and the renal medulla), alanine (from muscle) and glycerol (from adipose tissue). Much of the glucose thus produced is taken up by the brain. The low concentrations of glucose and insulin result in little uptake of glucose by non-neuronal tissue, net breakdown of

protein by skeletal muscle, liberation of fatty acids from adipose tissue (lack of restraint of the insulin-sensitive hormone lipase) and ketone body formation (provides fuel for muscle, brain and adipose tissue). The liberated fatty acids become the preferred fuel for muscle, thus sparing any plasma glucose for use by brain, erythrocytes and the renal medulla i.e. obligatory glucose-utilising tissues (Frayn, 1999; Allison and Go, 2004).

Food intake, digestion and absorption stimulate pancreatic release of insulin. The resultant increase in the insulin:glucagon ratio switches hepatic glycogen metabolism from breakdown to synthesis, reduces the release of fatty acids from adipose tissue and increases glucose uptake by skeletal muscle. The decrease in plasma fatty acid concentration and increase in glucose uptake reduces the drive for muscle to oxidise fatty acids. There follows an increase in glucose oxidation with increased production of lactate and pyruvate (due to increased glycolysis), increase in muscle glycogenesis and net protein synthesis (Frayn, 1999; Allison and Go, 2004). The increased substrate supply also stimulates hepatic gluconeogenesis and glycogenesis. The increase in insulin concentration also drives esterification and storage of fatty acids as triacylglycerol in adipocytes.

1.2.3 Metabolic effects of short-term fasting

As liver glycogen stores are virtually depleted within 24 hours (Rothman *et al.*, 1991), gluconeogenesis supplies the requirements of the brain and other

glucose-requiring tissues. The low insulin:glucagon ratio and the increased supply of gluconeogenic substrates stimulates gluconeogenesis. Falling insulin concentrations lead to both net proteolysis in muscle, with release of alanine and glutamine, and lipolysis in adipose tissue, with release of glycerol and non-esterified fatty acids (NEFA). The increased availability of NEFA directly stimulates muscle oxidation of fat rather than glucose. Gluconeogenesis at this stage proceeds at the expense of muscle protein but given that the brain requires around 100-120 g of glucose/day, the rate of muscle protein breakdown could be rapid, up to 210 g protein/day – as not all amino acids can be converted to glucose, around 1.75 g of muscle protein must be broken down to provide 1 g of glucose (Hill, 1992; Frayn, 1999; Allison and Go, 2004).

1.2.4 Perioperative reduction in insulin sensitivity

Impaired insulin sensitivity or 'insulin resistance' signifies a state of reduced peripheral and hepatic responsiveness to the biological actions of insulin (Allison and Go, 2004). Approximately 25% of normal individuals and up to 85% of type 2 diabetic populations are insulin resistant (Lebovitz, 2002). Insulin resistance is regarded as the major metabolic anomaly underlying the group of diseases that comprise the metabolic syndrome [type 2 diabetes, obesity, dyslipidaemia, hypertension, hypercoagulability and non-alcoholic steatohepatitis] (Krentz, 2002; Lebovitz, 2002) and it also occurs transiently after starvation, trauma and surgery (Wolfe *et al.*, 1979; Black *et al.*, 1982; Krentz, 2002; Nygren, 2006).

There are two main sites of insulin resistance: peripheral tissue (mainly skeletal muscle) and the liver. The former contributes to the development of early postoperative insulin resistance (*vide infra*). Hepatic insulin resistance, on the other hand, is an important underlying cause of the metabolic syndrome (Leclercq *et al.*, 2007) whereby central obesity is thought to act as a source of free fatty acids, reactive oxygen species (*vide infra*), tumour necrosis factor and other adipokines that impair insulin action in the liver (Leclercq *et al.*, 2007). Furthermore, hepatic insulin resistance has been demonstrated to be present 3 days after surgery (Soop *et al.*, 2004). The mechanisms and pathways underlying the development of hepatic insulin resistance, mainly within the context of the metabolic syndrome, have been previously reviewed (Leclercq *et al.*, 2007) and will not be considered further.

Studies in patients with insulin resistant states such as type 2 diabetes have demonstrated the development of insulin resistance in muscle to be attributed to decreased insulin-stimulated muscle glycogen synthesis, which appears to be at least partly due to defects in glucose uptake via GLUT-4 transporters (Shulman, 1999). Both raised plasma fatty acid concentrations and defects in mitochondrial function (*vide infra*) are associated with intramyocellular accumulation of lipid metabolites. These lead to defective GLUT-4 activity by abolishing insulin activation of IRS-1-associated phosphatidylinositol 3-kinase activity (Figure 1.1), thus interfering with insulin-mediated activation of GLUT-4 (Petersen and Shulman, 2006). In healthy volunteers a marked reduction in insulin sensitivity occurs after short-term (1-3 days) fasting (Newman and

Brodows, 1983; Nygren *et al.*, 1997a; Svanfeldt *et al.*, 2003). Although the cellular mechanisms underlying the development of postoperative insulin resistance following short-term fasting remain to be elucidated (*vide infra*), the increased levels of plasma fatty acids (Nygren *et al.*, 1997a) and reduction in insulin-stimulated glucose uptake (Mansell and Macdonald, 1990; Nygren *et al.*, 1997b) suggest that such impairment in glucose metabolism may also result from defective GLUT-4 activity.

A reduction in insulin sensitivity also occurs as part of the metabolic response to stress such as trauma (Black *et al.*, 1982), burn injury (Wolfe *et al.*, 1979) and sepsis (Little *et al.*, 1987; Carlson, 2004). More recently, a number of studies have demonstrated a reduction of up to 50% in insulin sensitivity (Nordenstrom *et al.*, 1989; Brandi *et al.*, 1990; Ljungqvist *et al.*, 1994; Thorell *et al.*, 1994; Nygren *et al.*, 1998a; Nygren *et al.*, 1998b; Soop *et al.*, 2001) following uncomplicated elective surgery in healthy non-diabetic patients. Seven healthy patients were studied before and 24 hours after elective open cholecystectomy (Nordenstrom *et al.*, 1989). Compared with a control group of 5 patients undergoing elective inguinal hernia repair, but subjected to an otherwise almost identical perioperative care protocol, the cholecystectomy group had significantly increased postoperative plasma concentrations of glucose (15%) and insulin (50%). These were associated with significant reductions in glucose transport (35%) and insulin-stimulated lipogenesis (50%) in isolated fat cells (Nordenstrom *et al.*, 1989). Another study of 7 patients (Brandi *et al.*, 1990) with a normal glucose-tolerance test before and after uncomplicated elective left

colonic resection demonstrated postoperatively the hallmarks of surgery-induced hypercatabolism (increased protein oxidation and energy expenditure), associated with increased plasma concentrations of counter-regulatory hormones (cortisol, glucagon, prolactin and growth hormones) and urinary output of catecholamines. These changes were associated with an eight-fold increase in insulin needed to maintain euglycaemia during 24 hours of parenteral nutrition compared to preoperative requirements. Furthermore, 24 hours of insulin supplementation during parenteral nutrition normalised glucose oxidation, restrained lipolysis and preserved protein stores. However, in a study of 10 patients undergoing elective open cholecystectomy (a moderate surgical stress), there was a 54% reduction in insulin sensitivity on the first postoperative day, as determined by hyperinsulinaemic-euglycaemic clamps (Thorell *et al.*, 1994). A further study of 16 patients undergoing elective open cholecystectomy (Thorell *et al.*, 1996b), using the same anaesthetic and surgical protocol as the aforementioned study (Thorell *et al.*, 1994), reported a slight but significant increase in plasma concentrations of noradrenaline and glucagon, but no increase in the concentrations of other counter-regulatory hormones (adrenaline, growth hormone and cortisol) on the first postoperative day. However, it is possible that the sampling time points (basal, postoperative day 1, day 5 day 9 and day 20) in the aforementioned study (Thorell *et al.*, 1994) may have missed earlier peaks in the concentrations of these hormones. Thus the role played by these hormones in the aetiology of postoperative insulin resistance remains unclear.

Hepatic and muscle insulin resistance and increased reliance on fat oxidation have been observed in burn (Wolfe et al., 1979) and septic (Little *et al.*, 1987; Agwunobi *et al.*, 2000; Carlson, 2003; Carlson, 2004) patients. A study that examined the impact of surgical stress on intermediary metabolism in 9 patients undergoing major abdominal surgery (Brandi *et al.*, 1993) found similar changes following uncomplicated elective surgery. This insulin resistance was associated with both a reduction in peripheral glucose uptake (Thorell *et al.*, 1999a) and non-oxidative glucose disposal (mainly glycogen synthesis) (Brandi et al., 1993; Thorell et al., 1999a). The contribution of reduced energy intake and bed rest to the development of perioperative insulin resistance was examined in another study that compared 7 patients undergoing moderate to major abdominal surgery with 6 healthy volunteers who had a similar period (24 hours) of rest and reduced energy intake (Nygren et al., 1997b). During insulin infusion, 20-30% reductions in insulin-stimulated glucose uptake were found as a response to 24 hours of bed-rest and reduced energy intake in healthy controls. Another study later reported that it was reduced energy intake but not bed-rest that resulted in a decline in peripheral insulin sensitivity (Nygren et al., 1997a). Reduced insulin sensitivity was related to the magnitude of the operation performed (Thorell *et al.*, 1993) and persisted for up to 3 weeks postoperatively in another study of 10 patients undergoing elective open cholecystectomy (Thorell et al., 1994). The degree of postoperative insulin resistance was shown to correlate with length of postoperative hospital stay in a retrospective analysis of data pooled from a number of Swedish studies over a period of 6 years ($r^2=0.28$, $P=0.0001$, $N=60$)

(Thorell *et al.*, 1999b). Multiple regression analysis of these data found that type of surgery (major or minor operation), perioperative blood loss and postoperative insulin resistance were independent predictors of length of hospital stay. The overall predictive value of this regression model was 71%. Furthermore, the presence of postoperative hyperglycaemia, a consequence of insulin resistance, has been found to increase postoperative mortality and morbidity significantly (van den Berghe *et al.*, 2001; Van den Berghe *et al.*, 2003). In a study of intensive insulin therapy in 1548 patients (87% of whom did not have a history of diabetes) admitted to a Belgian ICU (63% of the admissions followed cardiac surgery), the presence of hyperglycaemia (mean morning blood glucose level of 8.5 mmol/L in patients treated in the conventional therapy group) was associated with significantly increased ICU mortality (8% *versus* 4.6%), increased in-hospital mortality (10.9% *versus* 7.2%), increased septic complications (7.8% *versus* 4.2%) and prolonged mechanical ventilation (median 12 *versus* 10 days), when compared to patients who were randomised to an intensive insulin regimen to maintain normoglycaemia [mean morning blood glucose level of 5.7 mmol/L] (van den Berghe *et al.*, 2001). The improvement associated with intensive insulin therapy is thought (Vanhorebeek *et al.*, 2007) to result from the prevention of glucose-induced toxicity to the mitochondria (Vanhorebeek *et al.*, 2005), endothelium (Langouche *et al.*, 2005) and immune cells (Weekers *et al.*, 2003) and not the insulin dose *per se* (Vanhorebeek *et al.*, 2007).

1.2.5 Cellular pathways involved in the development of perioperative insulin resistance

To date no studies have examined the cellular and molecular pathways leading to the development of perioperative insulin resistance. However, valuable insights may be gained from studies of the effects of fasting and refeeding on carbohydrate and fat oxidation; and those of other physiological states associated with insulin resistance, such as type 2 diabetes, obesity and the metabolic syndrome.

The adaptive changes in skeletal muscle metabolism following fasting increase fat oxidation and decrease carbohydrate oxidation (COX), thus conserving glucose in times of limited supply (Mansell and Macdonald, 1990; Webber *et al.*, 1994). The decrease in COX is mediated by a decrease in the activity of the mitochondrial enzyme pyruvate dehydrogenase complex [PDC] (Sugden *et al.*, 1993). PDC has a key role in muscle metabolism as it controls the entry of carbohydrate-derived pyruvate into the tricarboxylic acid cycle (Figure 1.2). Regulation of the activity of PDC is therefore an important component of glucose homeostasis, whereby activation of PDC promotes glucose disposal and suppression conserves glucose (Sugden *et al.*, 2001).

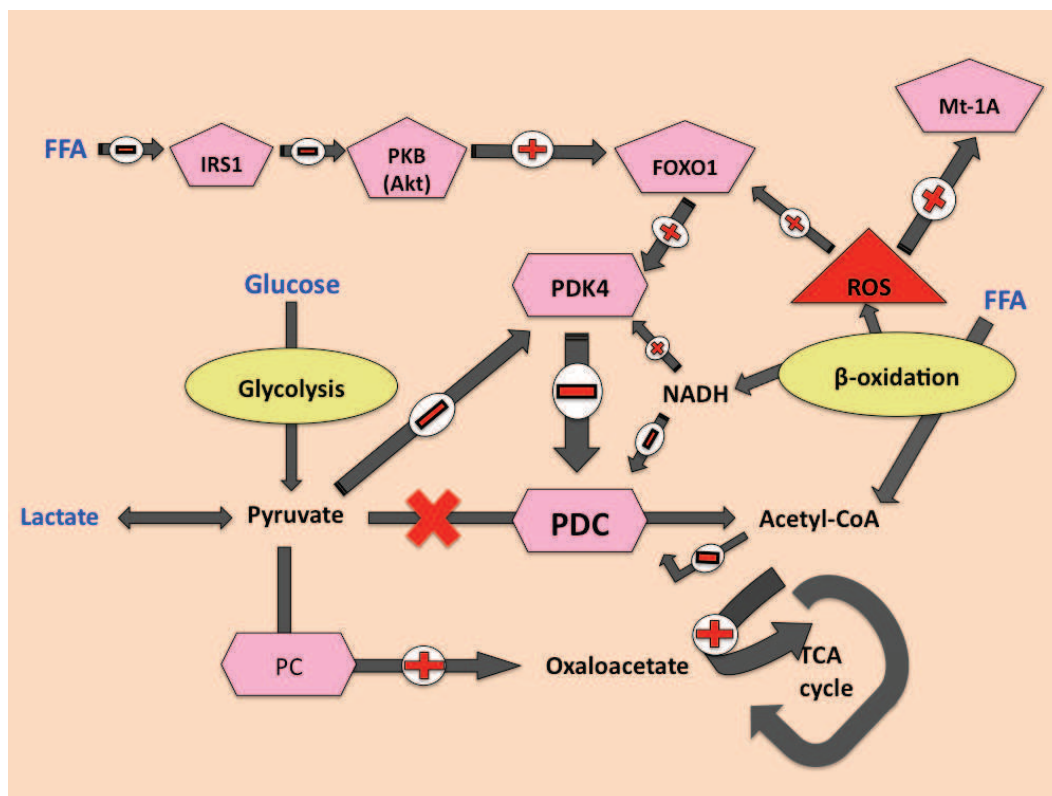

Figure 1.2: Regulation of pyruvate dehydrogenase complex (PDC) activity. PDC controls the entry of carbohydrate-derived pyruvate into the tricarboxylic acid (TCA) cycle. It is regulated by pyruvate dehydrogenase kinase 4 (PDK4) and increased concentrations of NADH and acetyl-CoA, which inactivate PDC, thereby inhibiting carbohydrate oxidation. Increased oxidation of free fatty acids (FFA) induces the nuclear translocation of forkhead transcription factor (FOXO1) and increases the generation of NADH, both of which act to upregulate PDK4 expression and inhibit PDC, thereby linking the processes of carbohydrate and fat oxidation. Increased FFA oxidation also increases generation of reactive oxygen species (ROS) which induce the activation of FOXO1 and upregulate the expression of metallothionein-1A (Mt-1A). Increased concentrations of FFA also act to interfere with insulin signalling pathways, via effects on IRS-1 and protein kinase B (PKB), see Figure 1.1, leading to decreased PDC activity. Finally inhibition of PDC activity increases the diversion of pyruvate to oxaloacetate (via the enzyme pyruvate carboxylase, PC) leading to increased citrate formation, the latter suppressing glucose uptake and glycolysis.

PDC is regulated by pyruvate dehydrogenase kinase (PDK) which phosphorylates and inactivates PDC thereby inhibiting COX. Of the four isoforms of PDK, PDK4 is the one predominantly expressed in human skeletal muscle (Spriet *et al.*, 2004). PDK4 is thought to be a 'lipid-status'-responsive PDK isoform facilitating fatty acid oxidation by 'sparing' pyruvate for oxaloacetate formation (Sugden *et al.*, 2001). In skeletal muscle, increased diversion of pyruvate to oxaloacetate facilitates the entry of acetyl-CoA derived from fatty acid β -oxidation into the TCA cycle leading to citrate formation. The latter acts as a signal of fatty acid abundance that suppresses glucose uptake and glycolysis (Sugden *et al.*, 2001). The activity of the PDKs is regulated by both end-product inhibition by the common products of glucose and fatty acid metabolism (acetyl-CoA and NADH), and the opposing effects of intermediates of metabolism (Sugden and Holness, 1994; Sugden *et al.*, 2001). Examples of the latter include the acute suppression of PDK activity by pyruvate and conversely the acute activation of PDK by the high concentration ratios of acetyl-CoA to CoA and of NADH to NAD⁺ in the mitochondria following increased rates of β -oxidation (Sugden and Holness, 1994; Sugden *et al.*, 2001). PDK4 expression is also regulated by forkhead transcription factor-1, FOXO1, (Furuyama *et al.*, 2003) which acts to mediate the effects of insulin action on gene expression (Accili and Arden, 2004). In the liver, FOXO1 also promotes the transcription of genes that increase glucose production (Accili and Arden, 2004).

Previous studies (Sugden *et al.*, 1993; Wu *et al.*, 1999; Pilegaard *et al.*, 2003; Spriet *et al.*, 2004; Tsintzas *et al.*, 2006) have demonstrated that 15-48 hour periods of fasting resulted in increased expression of PDK4, increased PDK activity and decreased PDC activity. The aforementioned changes may have resulted from increased availability of circulating free fatty acids (FFA), which induce the nuclear translocation of the FOXO1 (via the IRS-1/PKB pathway, Figure 1.2). FOXO1 can bind directly to the promoter region of the PDK4 gene thereby mediating the upregulation of PDK4 mRNA (Furuyama *et al.*, 2003). In support of this hypothesis, animal studies have demonstrated the fasting-induced upregulation of FOXO1 mRNA and protein expression (Furuyama *et al.*, 2003), although human studies have failed to demonstrate this (Tsintzas *et al.*, 2006). Similarly, studies have demonstrated conflicting findings regarding the role played by Akt in insulin resistance pathways (Kim *et al.*, 1999; Kruszynska *et al.*, 2002; Brozinick *et al.*, 2003). The increased cellular availability of FFA also augments the rate of FFA oxidation thereby leading to increased mitochondrial long-chain acyl-CoA oxidation and increased ROS generation. Given that ROS can induce the activation of FOXO in cell lines (Nakamura and Sakamoto, 2008) and have been implicated in the development of insulin resistance (Evans *et al.*, 2002; Houstis *et al.*, 2006), the measurement of indicators of oxidative stress, such as metallothionein-1A (Mt-1A) (Nath *et al.*, 2000), pentanes (Aghdassi and Allard, 2000) or products of lipid peroxidation (Niki, 2008), could offer further insights into the mechanisms that induce perioperative insulin resistance.

1.3 Preoperative fasting and carbohydrate loading

Current elective surgical practice is to fast patients for 6 hours for solids and 2 hours for clear liquids preoperatively, which is based on historical concerns of increased risks of aspiration of stomach contents during anaesthesia (Maltby, 2006). However, delays and changes in operating schedules result in patients being fasted for longer periods – even up to 18 hours (Diks *et al.*, 2005). The dogma of preoperative fasting has been challenged recently and both animal (Ljungqvist *et al.*, 1986; Ljungqvist *et al.*, 1987; Ljungqvist *et al.*, 1990; Esahili *et al.*, 1991; Alibegovic and Ljungqvist, 1993; Friberg *et al.*, 1994; Bark *et al.*, 1995; Nettelbladt *et al.*, 1997; van Hoorn *et al.*, 2005a; van Hoorn *et al.*, 2005b) and human (Newman and Brodows, 1983; Jensen *et al.*, 1987; Fryburg *et al.*, 1990; Gallen *et al.*, 1990; Rothman *et al.*, 1991; Webber and Macdonald, 1994; Webber *et al.*, 1994; Samra *et al.*, 1996; Nygren *et al.*, 1997a; Nygren *et al.*, 1997b; Nygren *et al.*, 1998b; Tsintzas *et al.*, 2006) studies have demonstrated adverse metabolic effects caused by preoperative fasting.

1.3.1 Preoperative fasting: History and current guidelines

The history behind the dogma of preoperative fasting has been reviewed comprehensively (Maltby, 2006). It appears that the adoption and blanket imposition of the '*nil per os* (NPO) from midnight' guideline for healthy patients undergoing elective surgery, without due distinction between solids and liquids,

arose following transfer of principles of emergency anaesthesia to elective practice, incorrect deductions from the results of animal experiments and the perceived ease (Maltby, 2006) with which such guidelines could be followed in clinical practice.

In the last two decades a number of clinical studies have challenged the traditional belief that *all* healthy patients undergoing elective surgery should be NPO from midnight. A meta-analysis of these studies concluded that intake of oral liquids was safe until 2 hours before general anaesthesia (Soreide *et al.*, 1997). A Cochrane review of 22 trials with 2270 participants similarly found that amongst healthy, non-pregnant, adult patients undergoing elective surgery, there were no reported cases of aspiration/regurgitation and no evidence of a difference in residual gastric volume or pH of gastric contents when a shortened fluid fast (90-180 min preoperatively) was compared with a standard fast (NPO from midnight) (Brady *et al.*, 2003). Furthermore, the volume of fluid intake did not have an impact on participants' gastric volume or pH when compared to a standard fast. Even in patients with co-morbid conditions (American Society of Anaesthesiologists grade IV/V) undergoing emergency surgery, aspiration occurred infrequently and mortality was low (1:71,829) (Warner *et al.*, 1993).

Current guidelines from various national anaesthetic societies permit a light meal (dry toast and clear liquid) not less than 6 hours before surgery and unrestricted clear liquids (water, fruit juice without pulp, carbonated drinks, clear tea and black coffee) until 2 hours before surgery (Soreide *et al.*, 1997; Smith, 2006). The

intake of these fluids is, however, unlikely to have a major effect on the metabolic state of the body which remains in the fasted state. Recently, several authors (Ljungqvist, 2004; Nygren, 2006) have raised concerns about performing surgery in the 'metabolically-stressed' state after overnight fasting, especially as surgery itself causes severe catabolic stress (Moore, 1959; Cuthbertson, 1980b; Cuthbertson, 1980a). Thence followed a number of experiments that compared the effects and outcomes of undergoing surgery in the fasted and 'fed' states.

1.3.2 Animal studies on the metabolic effects of preoperative fasting

Evidence that short-term fasting has adverse effects on the metabolic and haemodynamic responses to stress was clear from rat experiments dating back to 1945 (Diks et al., 2005). Compared to fasted rats, fed rats were found to lose less nitrogen and have a better haemodynamic response following experimental haemorrhage. Numerous investigators (Table 1.2) further studied the effects of fasting and feeding prior to exposure to various stresses on mortality (Ljungqvist *et al.*, 1987; Esahili *et al.*, 1991; Alibegovic and Ljungqvist, 1993), liver glycogen metabolism (Ljungqvist *et al.*, 1990; Alibegovic and Ljungqvist, 1993), endocrine responses (Ljungqvist et al., 1990), skeletal muscle function (Friberg *et al.*, 1994) and enteric bacterial translocation (Bark *et al.*, 1995; Nettelbladt *et al.*, 1997).

Table 1.2: Animal studies investigating the effects of fasting prior to surgical stress. Adapted and updated with permission from Diks *et al* (Diks et al., 2005). Abbreviations: **ADMA**, asymmetrical dimethylarginine; **GSH**, glutathione; **IL-6**, interleukin-6; **IR**, ischaemia-reperfusion; **MDA**, malondialdehyde; **MPO**, myeloperoxidase.

Study	Study groups	Stress	Variable(s) examined	Results
(Ljungqvist et al., 1987)	Fed <i>versus</i> 24-hour fast, then stress	Haemorrhage	Glucose concentrations, 7-day survival	Hyperglycaemia developed in fed but not in fasted rats. All fed rats survived, whereas all fasted rats died.
(Esahili et al., 1991)	Fed <i>versus</i> 24-hour fast, then stress	Endotoxin challenge (intravenous or intraperitoneal)	7-day survival	Fasting associated with 210 - 240% higher mortality in intravenously-treated group and 190 - 200% higher mortality in intraperitoneally-treated group.
(Alibegovic and Ljungqvist, 1993)	24-hour fast followed by either 30% glucose <i>or</i> 0.9% saline	Haemorrhage	7-day survival, liver glycogen concentrations	All fasted animals died within 3 hours post-haemorrhage, but all fed animals (given glucose infusion pre-haemorrhage) recovered. Liver glycogen concentrations were 600%

	infusion, then stress			higher in the fed group.
(Friberg et al., 1994)	Fed <i>versus</i> 24-hour fast, then stress	Haemorrhage	Muscle function	After 24-hour fast there was loss of muscle strength, even before exposure to haemorrhagic shock. After haemorrhage muscle strength lower in fasted group.
(Bark et al., 1995)	Fed <i>versus</i> 24-hour fast, then stress	Haemorrhage	Presence of enteric bacteria in mesenteric lymph nodes	Incidence of mesenteric lymph nodes with enteric bacteria was higher in fasted rats ($P<0.05$) and the numbers of bacteria was greater ($P<0.01$).
(Nettelbladt et al., 1997)	Fed <i>versus</i> 24 and 48-hour fast	1. Fasting only 2. Haemorrhage	Number of coliform bacteria in caecum, bacterial adherence to epithelium	24 and 48-hour fasts increased number of coliform bacteria in caecum by a factor of 25 and 100, respectively. Increase in bacterial adherence to intestinal epithelium by factor of 3000.

(van Hoorn et al., 2005b)	Fed <i>versus</i> 16-hour fast	Intestinal ischaemia-reperfusion model	Liver glycogen concentration, myeloperoxidase activity, reduced & oxidised tissue glutathione, ADMA concentration, IL-6 concentration	Liver glycogen concentration significantly lower (48.2%) in fasted rats than in fed rats. Lung myeloperoxidase activity significantly lower in fed group than fasted group. Lung GSH concentration significantly higher in fed group. Fed GSH concentration almost retained at level of sham fasted animals. Fed group had significantly lower ADMA and IL-6 concentrations compared to fasted animals.
(van Hoorn et al., 2005a)	Fed <i>versus</i> 13-hour fast	Intestinal ischaemia-reperfusion model	Organ function & vitality, severity of oxidative stress, energy status of liver & intestine	Heart performance after intestinal IR worse in fasted group than in fed group who maintained normal values. Markers of oxidative stress (MDA concentration) higher in intestine & lungs of fasted animals. Lower ATP/ADP in liver & intestine of fasted animals.

These studies proved that the metabolic state (fed *versus* fasted) of animals prior to exposure to stress was related to mortality and other outcomes following the stress. Although the underlying mechanisms are yet to be elucidated, a number of theories have been proposed. The preservation of liver glycogen stores (Ljungqvist et al., 1990; Alibegovic and Ljungqvist, 1993) in fed animals permits the rapid release of glucose into the bloodstream (Ljungqvist et al., 1987; Alibegovic and Ljungqvist, 1993; Bark et al., 1995) following stresses such as experimental haemorrhage. The resultant hyperosmolar state leads to beneficial effects on fluid homeostasis by increasing plasma refill, improving heart function and increasing peripheral blood flow (Ljungqvist *et al.*, 1986; Ljungqvist et al., 1990). Furthermore, preservation of liver glycogen is thought to reduce the need for mobilisation of muscle glycogen stores (Diks et al., 2005), to enable gluconeogenesis, which in turn preserves muscle strength both before and after exposure to stress (Friberg et al., 1994; Diks et al., 2005). Recent data also suggest that liver glycogen may be of importance in maintaining normal levels of antioxidant enzymes (van Hoorn et al., 2005a; van Hoorn et al., 2005b). An attenuated endocrine stress response in fed animals (Ljungqvist et al., 1986) reduced the ensuing catabolic response (Ljungqvist et al., 1990). Finally, the preservation of intestinal energy stores (van Hoorn et al., 2005a) and, therefore, integrity of the mucosal barrier, may protect against enteric bacterial translocation under conditions of stress (Diks et al., 2005; van Hoorn et al., 2005a; van Hoorn et al., 2005b).

1.3.3 Human studies on the metabolic effects of preoperative fasting

Few human studies have examined the effects of preoperative fasting on morbidity and mortality (Diks et al., 2005). However, the metabolic effects of short-term fasting in healthy humans have been well characterised. A decrease in insulin sensitivity of peripheral tissues (Newman and Brodows, 1983; Nygren et al., 1997a; Tsintzas et al., 2006), regarded as a marker of perioperative metabolic-stress (Thorell et al., 1999b), leads to a decrease in muscle glucose uptake (Gallen et al., 1990; Mansell and Macdonald, 1990; Webber et al., 1994; Tsintzas et al., 2006) which is accompanied by a reduction in oxidative glucose disposal (Mansell and Macdonald, 1990; Webber and Macdonald, 1994; Nygren et al., 1997b) and either a decrease (Nygren et al., 1997b; Nygren et al., 1998b) or no change (Mansell and Macdonald, 1990; Webber et al., 1994) in non-oxidative glucose disposal. An increase in resting energy expenditure occurs due to the metabolically more expensive processes of gluconeogenesis and ketogenesis (Webber and Macdonald, 1994). Elevations in plasma fatty acid concentrations (Samra et al., 1996; Nygren et al., 1997a; Tsintzas et al., 2006) are accompanied by decreases in the antilipolytic effects of insulin (Jensen et al., 1987), although this latter finding has not been reproduced in other studies (Newman and Brodows, 1983; Webber et al., 1994). Whole body protein catabolism is increased (Fryburg et al., 1990), but in contrast to perturbations in fat metabolism, muscle remains sensitive to the antiproteolytic effect of insulin (Fryburg et al., 1990). Finally, depletion of liver glycogen stores occurs after as little as 24 hours of fasting (Rothman et al., 1991; Thorell *et al.*, 1996; Frayn,

1999). The resulting metabolic state where easily utilisable energy is unavailable, especially during times of increased metabolic demand, is thought to have a detrimental effect on clinical outcome (Soop et al., 2001; Yuill *et al.*, 2005).

1.3.4 Preoperative carbohydrate loading *versus* fasting

The aforementioned studies demonstrated that an insulin resistant, 'metabolically-stressed' state can result from even short periods of fasting. Furthermore, animal studies showed a clear benefit from being in a fed as opposed to a fasted state at the onset of stress (Nygren *et al.*, 2001). Therefore, a number of human studies (Ljungqvist et al., 1994; Nygren *et al.*, 1995; Nygren et al., 1998a; Nygren *et al.*, 1999; Hausel *et al.*, 2001; Soop et al., 2001; Henriksen *et al.*, 2003; Bisgaard *et al.*, 2004; Soop et al., 2004; Svanfeldt *et al.*, 2005; Yuill et al., 2005; Breuer *et al.*, 2006; Melis *et al.*, 2006; Svanfeldt *et al.*, 2007) explored the possibility that preoperative feeding, instead of fasting, enabled a more favourable metabolic response to stress such as surgery (Table 1.3).

Table 1.3: Studies investigating the effects of carbohydrate loading *versus* fasting prior to surgery. Abbreviations: **CHO**, carbohydrate; **EGP**, endogenous glucose production; **FFA**, free fatty acids; **GIR**, glucose infusion rate; **ICU**, intensive care unit; **IR**, insulin resistance; **LOS**, length of stay; **NEFA**, non-esterified fatty acids; **Preop**, preoperative; **Postop**, postoperative; **WGD**, whole-body glucose disposal.

Study	Study groups	Variable(s) examined	Results	Limitations of studies
(Ljungqvist et al., 1994)	Patients undergoing elective open cholecystectomy receive either glucose infusion [Glucose 200 mg/ml, 5 mg/kg/min] (N=6) <i>or</i> no infusion (N=6) during preoperative fasting. Insulin sensitivity measured before surgery and on first postop day.	Glucose, insulin & stress hormone concentrations, insulin sensitivity	Postop glucose concentrations elevated in both groups but insulin concentrations elevated only in control group. No differences on postop stress hormone concentrations between two groups. Postop insulin sensitivity reduced by 55% in control group <i>versus</i> 32% in glucose group ($P<0.01$).	Small number of patients studied. Allocation by date of birth (not computer generated randomisation codes). No information on whether preoperative carbohydrate ingestion was controlled prior to measuring insulin sensitivity. Insulin sensitivity measured on day 1 postop. thereby potential confounding by effects of

				postoperative fasting and bed rest. Sampling time point of hormone measurements (day 1 postop) may have missed an earlier peak in concentrations on operative day.
(Nygren <i>et al.</i> , 1995)	Patients undergoing elective laparoscopic cholecystectomy (N=11) and parathyroid surgery (N=1). Randomised to 400 ml CHO rich drink [285 mOsm/kg, 12% CHO] (N=6) <i>or</i> 400 ml water (N=6) 4 hours before induction of anaesthesia.	Gastric emptying rate, insulin & glucose concentrations	Despite presence of anxiety and hunger on morning of surgery, oral CHO drink leaves stomach within 90 min of ingestion. In CHO-drink group elevated insulin concentrations 40 min after ingestion mimicked those produced by intravenous administered glucose infusions (Ljungqvist <i>et al.</i> , 1994).	Only ASA grade I/II patients studied and these are not representative of everyday patients. Method of allocation of patients to study groups not stated.

(Thorell <i>et al.</i> , 1996a)	Patients undergoing elective open cholecystectomy receive either glucose infusion [Glucose 200 mg/ml, 5 mg/kg/min] (N=8) <i>or</i> no infusion (N=8) preoperatively.	Hormonal and FFA responses to surgery, liver glycogen concentrations	Preoperative FAA concentrations lower in glucose group. CHO loading had little effect on stress hormone response to surgery but maintained liver glycogen concentrations (65% higher than in control group).	Allocation to study group by date of birth.
(Nygren <i>et al.</i> , 1998b)	Patients undergoing elective hip surgery. Randomised to undergo surgery with (N=7) <i>or</i> without (N=6) hyperinsulinaemic, euglycaemic clamp. Insulin sensitivity assessed before, during and	Body metabolism, insulin sensitivity & endocrine responses	Plasma FAA higher in control group during surgery and postop. Cortisol concentrations decreased by 65% in insulin group postop but not in control group. Comparing preop and postop concentrations, no change seen in GIR or WGD in insulin group compared to decreases in GIR and WGD in control group. Glucose oxidation lower and fat oxidation higher during and after surgery in control	Method of allocation of the small number of patients to study groups not stated. Uneven gender distribution in study groups. No information on whether preoperative carbohydrate ingestion was controlled prior to measuring insulin

	immediately after surgery.		group.	sensitivity. Insulin clamps performed at different time points in study and control groups. EGP not measured.
(Nygren et al., 1999)	Patients undergoing elective colorectal (N=14) and hip surgery (N=16). Patients were randomised to receive CHO (800 ml of 12.5% iso-osmolar drink on evening before operation and 400 ml 2 hours before anaesthesia) or placebo drink preoperatively. In hip group insulin sensitivity measured 1 week preop	Insulin sensitivity, glucose kinetics	In patients undergoing hip surgery, 37% reduction ($P<0.05$) in insulin sensitivity postoperatively in fasted group whereas no reduction seen in CHO group. In patients undergoing colorectal surgery, 24.3% greater reduction in insulin sensitivity postoperatively in fasted group compared to CHO group (adjusted for confounding variables). Relative reduction in WGD after colorectal surgery greater in fasted compared to CHO group (-49% versus -26%, $P<0.05$).	No information on whether preoperative carbohydrate ingestion was controlled prior to measuring insulin sensitivity. Confounding of measurements of postop day 1 insulin sensitivity in colorectal group due to hypocaloric nutrition and bed rest. Study did not examine clinical outcomes such as length of hospital stay.

	and immediately postop. In colorectal group insulin sensitivity measured the day before surgery and 24 hours postop.			
(Soop et al., 2001)	Patients undergoing elective hip surgery (N=15). Randomisation (double-blinded) to preop CHO drink [800 ml of 12.5% iso-osmolar drink on evening before operation and 400 ml 2 hours before anaesthesia] (N=8) <i>or</i> placebo drink (N=7). Insulin sensitivity measured 1 week preop	Glucose kinetics & substrate utilization, insulin sensitivity	CHO group had lower concentrations of glycerol and NEFA preoperatively after ingestion of drink. Postop decreases in GIR and WGD less in CHO group than placebo group (-18% <i>versus</i> -43%, $P<0.05$) and (-19% <i>versus</i> -37%, $P<0.05$), respectively. CHO group had significantly increased glucose oxidation rates that persisted into postop period. Non-oxidative glucose disposal failed to increase postop in both groups in response to insulin infusion.	Method of allocation not stated. Small number of patients studied. Differences in EGP not determined.

	and immediately after surgery to avoid confounding effects of reduced calorie nutrition and bed rest.			
(Hausel <i>et al.</i> , 2001)	Consecutive patients undergoing elective laparoscopic cholecystectomy (N=174) and major colorectal surgery (N=78). Randomised to 3 groups: Preop CHO drink, preop placebo drink and fasted from midnight. CHO and placebo groups were double-blinded. CHO	CHO-drink related complications, residual gastric volume, gastric acidity, preop discomfort	No cases of pulmonary aspiration or drink-related complications. Median residual gastric fluid volumes similar in all 3 groups (CHO 20ml, placebo 20 ml and fasted 22 ml). Gastric pH similar in all 3 groups. CHO group had increased preop well-being compared to placebo and fasted groups. CHO drink relieved preop thirst, hunger, anxiety and malaise.	Method of allocation to study groups not stated. Only ASA I/II patients studied. RGV measured by double lumen NG tube. No data on outcomes such as length of hospital stay – despite large number of participants studied.

	group received 800 ml of 12.5% iso-osmolar drink on evening before operation and 400 ml 2 hours before anaesthesia.			
(Henriksen et al., 2003)	<p>Patients undergoing elective colorectal surgery (n=48) were randomised to 3 groups: preop CHO drink, preop CHO-peptide drink and preop fasting (allowed to drink water). Patients in intervention groups given 800 ml of the intervention drink the evening before and 400 ml 3 hours before</p>	<p>Residual gastric volumes (N=29), muscle glycogen concentrations and glycogen synthase activity, voluntary</p>	<p>No differences in residual gastric volume between groups. Although no differences were detectable in muscle glycogen concentrations between the groups, postop glycogen synthase activity was significantly decreased in the control compared to the intervention groups. Voluntary quadriceps muscle strength did not differ between the groups when analysed <i>per se</i> but pooled analysis of results from the 2 intervention groups showed significantly better muscle strength one month postop compared to control group. No changes in</p>	<p>Only ASA I/II patients studied. RGV measured using dye dilution technique. Analysis was not intention to treat. Data on length of hospital stay not given.</p>

	anaesthesia. CHO drink contained 12.5 g CHO/100 ml. CHO-peptide drink contained 12.5 g CHO/100 ml and 3.5 g hydrolyzed soy protein/100 ml.	strength, nutritional intake, ambulation, fatigue, anxiety, discomfort, endocrine response	thirst, hunger, anxiety and overall well-being.	
<i>(Soop et al., 2004)</i>	Patients undergoing elective hip surgery. Randomisation (double-blinded) to preop CHO drink (800 ml of 12.5% iso-osmolar drink on evening before operation and 400 ml 3 hours before surgery)	Insulin sensitivity 3 days postop, nitrogen balance in first 3 days postop, ambulation	EGP significantly lower and attenuated after surgery in CHO group compared to placebo group. Relative reduction in GIR on day 3 did not differ between groups. Nitrogen losses lower in CHO group than placebo group (difference of 25 mg/kg/day) but overall no difference in nitrogen balance. No differences in postop ambulation.	Only studied small number ASA I/II patients. No information on whether preoperative carbohydrate ingestion was controlled prior to measuring insulin sensitivity.

	(N=8) or placebo drink (N=6). Insulin sensitivity assessed 1 week preop and day 3 postop. Cumulative nitrogen balance calculated from end of surgery to day 3 postop.			
(Bisgaard <i>et al.</i> , 2004)	Patients undergoing elective laparoscopic cholecystectomy. Randomisation (double-blinded) to preop CHO drink [800 ml of 12.5% iso-osmolar drink on evening before operation and 400 ml 2 hours before surgery]	Well-being, appetite, fatigue, pain, nausea & vomiting on day 1 postop, sleep quality and physical activity	No cases of apparent or suspected pulmonary aspiration or other drink-related complications. No inter-group differences in scores of well-being, fatigue, appetite, nausea, vomiting, analgesic and antiemetic requirements, sleep quality or activity levels. Pain scores remained significantly raised for 4 days postop in CHO group.	Only ASA I/II patients studied. Excluded patients if more than 5 h elapsed between intake of beverage and initiation of anaesthesia. Excluded patients who developed postoperative complications. Study sample size calculated for a

	(N=43) <i>or</i> placebo drink (N=43).			secondary (not primary) endpoint. No intention to treat analysis.
(Yuill <i>et al.</i> , 2005)	Patients undergoing elective major upper gastrointestinal surgery. Randomisation (double-blinded) to preop CHO drink [800 ml of 12.6% iso-osmolar drink on evening before operation and 400 ml 2-3 hours before anaesthesia] (N=31) <i>or</i> placebo drink (N=34).	Tolerance and effects of preop CHO loading, effects on body composition, length of hospital stay	No instances of perioperative aspiration. At hospital discharge no differences in changes in endogenous fat reserves but loss of muscle mass significantly greater in control group. Trend towards reduced LOS in CHO group.	Anthropometry measurements used to determine body composition, no coefficient of variation given for these measurements. Analysis not intention to treat. No data on postoperative ambulation or nutrition provided. Postoperative glucose sensitivity not measured.
(Svanfeldt <i>et al.</i> , 2005)	Healthy volunteers (N=6) underwent 4 protocols in a randomised (unblinded)	Insulin sensitivity following	GIR significantly higher when CHO drink was given in morning compared to protocols without a morning dose. GIR not affected by	Preoperative carbohydrate ingestion was not controlled prior to measuring insulin

	<p>crossover manner. Protocols designed to mimic perioperative situation: Control group was fasted, one CHO group given 800 ml of 12.6% iso-osmolar CHO drink on the evening before the day of the clamp study, second CHO group given 400 ml of 12.6% iso-osmolar CHO drink on the morning of the clamp study, last CHO group given 800 ml of 12.6% iso-osmolar CHO drink on the evening before and another 400</p>	<p>different CHO regimens</p>	<p>the drink being given in the evening prior to the clamp study. Non-oxidative glucose disposal higher when drink had been ingested in morning. Insulin action enhanced by 50% three hours after ingestion of a morning dose of the CHO drink.</p>	<p>sensitivity. Unblinded study. No reference for sample size estimate calculation. EGP not measured.</p>
--	--	-------------------------------	---	---

	ml on the morning of the clamp study.			
(Melis <i>et al.</i> , 2006)	Patients undergoing elective orthopaedic surgery. Randomisation (blinded) to 3 groups: Control group (N=10) was fasted from midnight and 2 groups (N=10 in each) were given 2 different CHO beverages consumed 4 hours before surgery.	Cellular immune function, fluid homeostasis, thirst, hunger, nausea, anxiety & weakness	No incidents of pulmonary aspiration occurred. HLA-DR expression decreased significantly after surgery in control group where as no change was observed in CHO groups. Fasted patients experienced more thirst preop than CHO groups. No difference in other measures of well-being.	No information on allocation concealment. Study drinks served in glasses (not opaque bottles). Primary versus secondary outcomes not stated. Groups not comparable for age and gender (confounding variable for one of study outcomes).
(Breuer <i>et al.</i> , 2006)	ASA III-IV patients undergoing elective cardiac surgery (including type 2 diabetic patients). Randomized to 3 groups:	Postop insulin requirement, residual gastric	No differences in insulin requirements or residual gastric volumes between the different groups. No drink-related complications. CHO group experienced less thirst than control group but no differences in hunger, nausea,	Primary endpoint of study was a surrogate marker (insulin requirement) of postop insulin resistance. RGV estimated by passive

	<p>preop CHO drink (N=56) <i>versus</i> placebo drink (N=60) [double-blind] <i>versus</i> open-labelled control group (N=44) fasted from midnight. 800ml of CHO drink (12.5% CHO, isoosmolar) <i>or</i> placebo taken evening before surgery and 400 ml taken 2 hours before surgery. Morbidity was measured by organ dysfunction.</p>	<p>volume, preop discomfort, drink-related complications, morbidity</p>	<p>anxiety and dryness of mouth. CHO and placebo groups did not differ in thirst. CHO group required less intraoperative inotropes after initiation of CPB weaning. No differences in severity of illness scores, incidence of postop complications and durations of hospital/intensive care stay.</p>	<p>gastric reflux so possibility of underestimating GRV. Some of outcome variables not diagnosed according to accepted standards.</p>
<p>(Svanfeldt <i>et al.</i>, 2007)</p>	<p>Patients undergoing elective colorectal surgery. Randomisation</p>	<p>Postop whole-body protein &</p>	<p>Postop whole-body protein breakdown higher at baseline and during insulin stimulation in low CHO group. Surgery evoked more negative</p>	<p>Small number of patients studied. Per protocol (not intention to treat) analysis.</p>

	<p>to receive a preop drink with either high (125mg/ml, N=6) or low (25mg/ml, N=6) CHO load. 800 ml were ingested evening before surgery and 600-800 ml were taken until 2 hours before the estimated time for pre-medication. Insulin sensitivity assessed 5 days preop and on day 1 postop.</p>	<p>glucose kinetics</p>	<p>protein balance in low CHO group at baseline and during insulin stimulation. No effect of CHO on postop insulin sensitivity seen. Postop suppression of EGR less effective in low CHO group. Positive correlation between EGR and whole-body protein breakdown seen after surgery ($r^2=0.432$, $P=0.02$).</p>	<p>No reference given for sample size estimate calculation. Long fasting durations between preoperative serving of study drinks and initiation of anaesthesia. Carbohydrate intakes not standardised in 3 days prior to insulin-clamp measurements. Insulin clamps performed on day 1 post op thus possible confounding by postop hypocaloric nutrition and ambulation.</p>
--	---	-------------------------	---	---

The main objective of these studies on preoperative carbohydrate loading was to produce a change in metabolism similar to that occurring after breakfast, whereby the endogenous release of insulin 'turns-off' the overnight fasted state of metabolism (Ljungqvist and Soreide, 2003). Early studies achieved this through the use of intravenous glucose infusions (5 mg/kg/min) and demonstrated a 50% reduction in the development of postoperative insulin resistance in the carbohydrate-treated groups (Ljungqvist et al., 1994). The high dose of glucose in these infusions was necessary to induce a sufficiently high endogenous insulin response to change metabolism in the desired way (Ljungqvist *et al.*, 2002) but such a dose carried the risk of causing thrombophlebitis (Diks et al., 2005). An iso-osmolar drink was developed with sufficient carbohydrate to induce an insulin response similar to that after a meal (Ljungqvist et al., 2002) and an osmolality that permitted rapid emptying from the stomach (Nygren et al., 1995). These drinks were shown to empty from the stomach within 2 hours (Nygren et al., 1995), with no instances of pulmonary aspiration or other drink-related complications (Nygren et al., 1995; Nygren et al., 1999; Hausel et al., 2001; Soop et al., 2001; Henriksen et al., 2003; Bisgaard et al., 2004; Soop et al., 2004b; Yuill et al., 2005; Breuer et al., 2006; Melis et al., 2006) reported following over 6000 patient episodes (Ljungqvist et al., 2002). Furthermore, preoperative carbohydrate loading was shown to attenuate the postoperative decrease in peripheral (Nygren et al., 1998b; Nygren et al., 1999; Soop et al., 2001) and hepatic (Soop et al., 2004b; Svanfeldt et al., 2007) sensitivity to insulin, maintain hepatic glycogen reserves (Thorell et al., 1996), maintain muscle

glycogen synthesis (Henriksen et al., 2003; Svanfeldt et al., 2007), blunt the endocrine response to surgery (Nygren et al., 1998b; Nygren et al., 1999), attenuate the deterioration in postoperative whole-body protein balance (Yuill et al., 2005; Svanfeldt et al., 2007) and muscle function (Henriksen et al., 2003), and prevent surgery-induced immunosuppression (Melis et al., 2006). Finally, some studies have shown that preoperative carbohydrate loading was associated with improved patient well-being with decreased preoperative thirst (Hausel et al., 2001; Breuer et al., 2006; Melis et al., 2006), hunger and anxiety (Hausel et al., 2001), decreased postoperative nausea and vomiting (Hausel *et al.*, 2005) and a 20% reduction in length of hospital stay (Thorell et al., 1999; Ljungqvist et al., 2002), although other studies have failed to demonstrate similar effects (Henriksen et al., 2003; Bisgaard et al., 2004; Soop *et al.*, 2004a; Yuill et al., 2005; Breuer et al., 2006; Melis et al., 2006).

The majority of the aforementioned studies were undertaken on small numbers of patients and although preoperative feeding was associated with beneficial physiological effects, such as reduction in perioperative insulin resistance, it is yet to be proved conclusively that preoperative carbohydrate loading is associated with improved clinical outcomes such as reduction in mortality and morbidity. Nonetheless, preoperative carbohydrate feeding is now an accepted part of the evidence-based Enhanced Recovery After Surgery (ERAS) program which aims to allow patients to recover more quickly from major surgery, avoid the sequelae of traditional postoperative care (e.g. decline in nutritional status

and fatigue) and reduce healthcare costs by reducing hospital stay (Fearon *et al.*, 2005).

Although studies on carbohydrate loading have demonstrated beneficial physiological effects, the precise mechanism of action of these drinks is unclear (Ljungqvist *et al.*, 2002; Diks *et al.*, 2005). The effects on depleted glycogen stores, insulin sensitivity and oxidative stress have already been described but the cellular mechanisms that link these processes remain to be elucidated. The reduction in perioperative insulin sensitivity in non-diabetic subjects is similar to that seen in patients with type 2 diabetes (Ljungqvist *et al.*, 2002). Numerous studies on patients with type 2 diabetes have suggested a link between impaired mitochondrial function and the development of insulin resistance (Petersen *et al.*, 2003; Petersen *et al.*, 2004; Petersen and Shulman, 2006). Thus, it may be possible that preoperative carbohydrate loading attenuates the decrease in insulin sensitivity by preventing mitochondrial dysfunction (*vide infra*).

1.3.5 Perioperative glutamine and antioxidant supplementation

Perioperative glutamine and antioxidant supplementation have been shown to improve gastrointestinal perfusion, immune function and morbidity in critically ill patients (Houdijk *et al.*, 1998; Jones *et al.*, 1999; Roth, 2001; Bakalar *et al.*, 2006; Dechelotte *et al.*, 2006; Berger and Chioloro, 2007). Glutamine is a non-essential amino acid that possesses numerous biochemical, metabolic and physiological

functions and is required for health. It is a precursor that donates nitrogen for the synthesis of purines, pyrimidines, nucleotides and glutathione and is the most important substrate for renal ammoniogenesis. Glutamine also serves as a nitrogen transporter between various tissues. Finally, it represents the major metabolic fuel for enterocytes and many rapidly proliferating cells, including those of the immune system. Glutamine is thought to become a conditionally essential amino acid during episodes of catabolic stress such as in injury and sepsis (Roth, 2001). The effects of enterally administered glutamine were studied in a randomised study of 60 patients with multiple trauma [injury severity score (Baker *et al.*, 1974) of 20 or more]. Enteral feeds with and without glutamine were commenced within 48 hours of hospital admission. There was a significant 50% reduction in the incidence of pneumonia, bacteraemia and sepsis in the glutamine group (Houdijk *et al.*, 1998). In another randomised study of 78 critically ill intensive care patients, glutamine supplementation of enteral feeds led to a significant 30% reduction in hospital patient costs (Jones *et al.*, 1999). Parenteral alanyl-glutamine administration resulted in better-maintained glucose homeostasis (reduced insulin resistance) following multiple trauma in a randomised study of 40 patients (Bakalar *et al.*, 2006). Another randomised placebo-controlled study of 114 intensive care patients receiving glutamine-supplemented parenteral nutrition demonstrated reduced infectious complications, hyperglycaemia and insulin requirements in the glutamine-supplemented group (Dechelotte *et al.*, 2006). Finally, there is evidence that preoperative supplementation with immunomodulating nutrients results in

significant reductions in postoperative infectious complications (Braga *et al.*, 1999; Senkal *et al.*, 1999; Snyderman *et al.*, 1999; Tepaske *et al.*, 2001). However, the regimens used in the aforementioned studies required preoperative supplementation with immunomodulating nutrients 5 to 7 days prior to elective surgery which may not be practical in the clinical setting. Other groups have suggested that preconditioning with free radical scavengers such as ascorbate and vitamins E and A may provide an integrated approach to minimizing free radical-induced surgical complications (Baines and Shenkin, 2002; Orzechowski, 2003; Berger and Chioloro, 2007).

1.4 Mitochondrial function

Mitochondria produce ATP, serve as biosensors for oxidative stress, and through apoptosis, are effector organelles for cell death (Muravchick and Levy, 2006). Approximately 98% of inhaled oxygen is consumed by mitochondria (Duchen, 2004) and the supply of substrates for mitochondrial oxidation is the primary aim of ordered food intake, digestion and processing (Duchen, 2004). Disorders in mitochondrial function have been implicated in the pathogenesis of a number of disease states such as insulin resistance which in turn leads to a number of cardiovascular diseases (Petersen *et al.*, 2003). Furthermore, mitochondrial dysfunction may lead to increased oxidative stress thus placing many surgical patients at increased perioperative risk (Delogu *et al.*, 2001b; Muravchick and Levy, 2006).

1.4.1 Mitochondrial function in health

Mitochondria produce the ATP needed for normal cellular function and metabolic homeostasis by oxidative phosphorylation (Nelson *et al.*, 2008). This process is conducted by a series of five enzyme complexes located on the inner mitochondrial membrane (Figure 1.3).

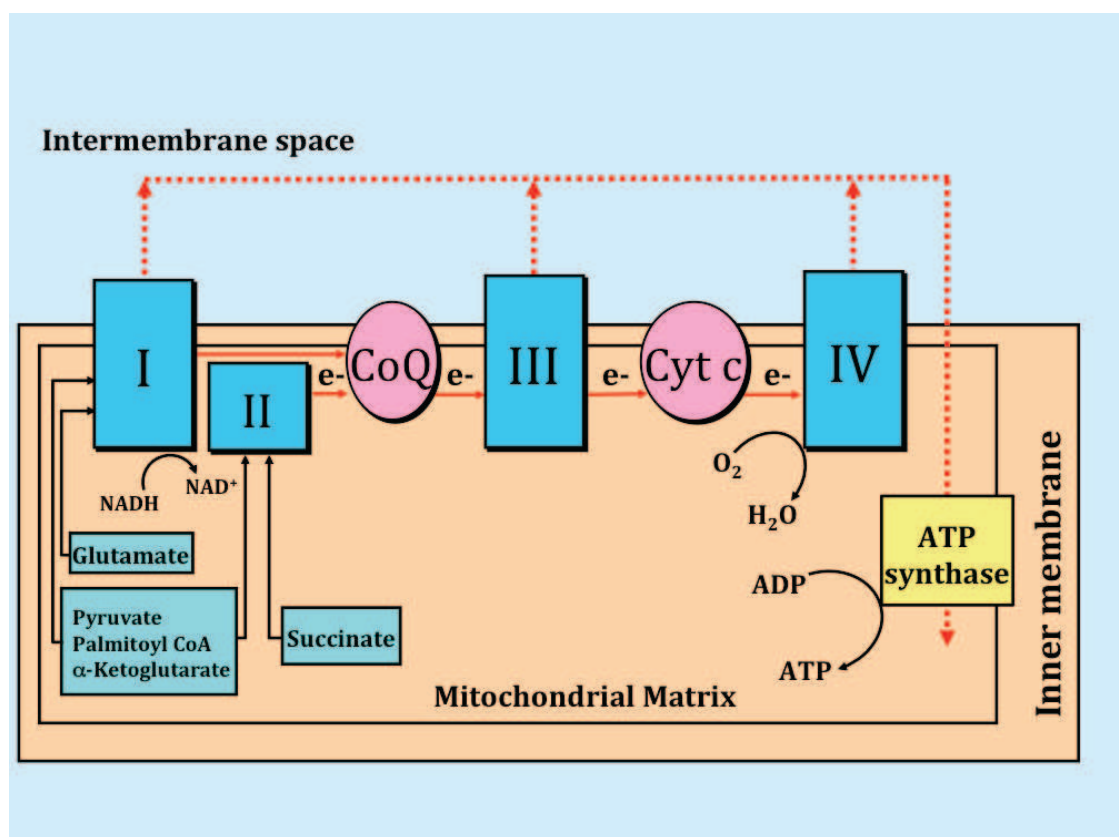

Figure 1.3: Schematic representation of the components needed for mitochondrial oxidative phosphorylation. The electron transport chain is located within the inner mitochondrial membrane and is comprised of the oxidase complexes I-IV, coenzyme Q (Co Q) and cytochrome c (Cyt C). Red arrows are indicative of the pathway of electron flow. Complexes I, III and IV pump hydrogen ions (dotted red arrows) into the intermembrane space and generate the electrochemical gradient that powers the phosphorylation of adenosine diphosphate (ADP) to adenosine triphosphate

(ATP) by ATP synthase. H₂O, water; NAD, nicotinamide adenine dinucleotide; NADH, reduced nicotinamide adenine dinucleotide; O₂, oxygen.

Four of these complexes comprise the mitochondrial electron transport chain (ETC) and function as a biochemical “conveyor belt” for electrons. These electrons are derived from oxidation of glucose or fatty acids and are transferred through mitochondrial membrane complexes (MMCs) I to IV via mobile electron carriers. At complexes I, III and IV protons are pumped out of the mitochondrial matrix into the intermembrane space. This action results in the generation of an electrochemical proton gradient which is used by the fifth enzyme complex (ATP synthase) to drive ATP synthesis. The ATP produced serves as the “currency” needed for most energy-requiring biological transactions.

1.4.2 Oxidative Stress

Mitochondrial oxidative phosphorylation is the major intracellular source of reactive oxygen species (ROS) or ‘free radicals’ such as superoxide, peroxide or hydroxyl radicals. These ROS are generated as by-products of the interaction between free electrons and oxygen (Muravchick and Levy, 2006) and are an unavoidable consequence of aerobic metabolism. Free radicals are highly reactive molecules that can degrade or destroy mitochondrial enzyme complexes, membranes and structural components of cellular microarchitecture,

either by direct contact or through lipid peroxidation (Muravchick and Levy, 2006). Intrinsic defence systems that include superoxide dismutase, catalase, glutathione peroxidase, copper, zinc superoxide dismutase and manganese superoxide dismutase protect against ROS-induced damage by converting free radicals into oxygen and water (Jackson *et al.*, 2002; Muravchick and Levy, 2006). Although these endogenous antioxidant defence systems effectively suppress ROS concentrations within the cell and mitochondria in health, these mechanisms become inadequate in many disease states. Rapid or overwhelming increases in ROS produce oxidative stress which can be cytotoxic via initiation of apoptosis or disruption of intracellular calcium regulation (Muravchick and Levy, 2006).

1.4.3 Mitochondrial dysfunction and insulin resistance

The cellular and molecular mechanisms of insulin resistance have been studied extensively with the aim of providing new therapeutic targets for the treatment and prevention of type 2 diabetes (Morino *et al.*, 2006). Studies on patients with type 2 diabetes have demonstrated glucose transport as the rate-limiting step for insulin-stimulated muscle glycogen synthesis. A reduction in the latter was the major factor responsible for insulin resistance in these patients (Morino *et al.*, 2006). These findings were also demonstrated in healthy insulin-resistant offspring of parents with type 2 diabetes suggesting that reduced insulin-stimulated glucose transport was an early event in the pathogenesis of the

disease (Morino et al., 2006). Subsequently, intramyocellular lipid concentrations, assessed by ^1H magnetic resonance spectroscopy (MRS), were found to correlate inversely with muscle insulin sensitivity (Krssak et al., 1999). Accumulation of intramyocellular lipid metabolites such as fatty acyl CoAs and diacylglycerol resulted from increased delivery of fatty acids from plasma and/or reduced mitochondrial β -oxidation. These metabolites activated serine/threonine kinases such as protein kinase C which phosphorylated the serine residues of IRS-1 leading to defects in insulin signalling, failure of GLUT-4 translocation and reduced insulin-stimulated glucose uptake (Morino et al., 2006). Activation of protein kinase C in hepatocytes similarly gave rise to fat-induced defects in insulin signalling which resulted in reduced insulin stimulation of glycogen synthesis and increased hepatic gluconeogenesis (Morino et al., 2006).

Further studies have linked defective mitochondrial function with intramyocellular accumulation of lipid metabolites and subsequent insulin resistance. Petersen et al. (Petersen et al., 2003) matched healthy lean elderly volunteers for body mass index and activity with younger subjects. Compared to younger controls, elderly subjects had higher concentrations of plasma glucose and insulin, a trend towards increased plasma fatty acid concentrations and a 40% lower rate of insulin-stimulated peripheral glucose uptake. This was associated with a 45% and 225% increase in triglyceride concentrations of muscle and liver, respectively, as assessed by ^1H MRS. In addition, elderly subjects had a 40% reduction in the rates of muscle mitochondrial oxidative and

phosphorylation activity, assessed by ^{13}C and ^{31}P MRS, respectively. These findings suggest that acquired loss of mitochondrial function, associated with ageing, may predispose to intramyocellular lipid accumulation, which results in insulin resistance through the mechanisms described earlier (Morino et al., 2006). Similar findings were noted in young lean insulin-resistant offspring of parents with type 2 diabetes where severe defects in insulin-stimulated muscle glucose metabolism were associated with an 80% increase in intramyocellular lipid concentrations and a 30% reduction in rates of mitochondrial ATP production (Petersen et al., 2004).

However, other investigators have suggested that mitochondrial abnormalities represent the end result of insulin resistance rather than its cause (Stump *et al.*, 2003). In this context, reduced insulin action in states of insulin resistance was associated with impaired mitochondrial enzyme synthesis and reduced mitochondrial oxidative phosphorylation in skeletal muscle (Stump et al., 2003). Inducing an insulin deficient state in seven type 1 diabetic patients resulted in significantly reduced muscle mitochondrial ATP production capacity which was accompanied by an increase in whole body oxygen consumption and alterations in transcript levels of genes involved in oxidative phosphorylation (Karakelides *et al.*, 2007). Thus reduced insulin action and the associated metabolic changes can downregulate muscle oxidative phosphorylation. Another theory is that mitochondrial dysfunction in insulin resistance, ageing and type 2 diabetes is a reflection of cumulative oxidative stress that involves damage to mitochondrial DNA (Ritz and Berrut, 2005). Finally, a study on the effects of intensive insulin

therapy on mitochondrial integrity and function in critically ill surgical patients demonstrated that hyperglycaemia had a toxic effect on liver, but not muscle, mitochondria (Vanhorebeek *et al.*, 2005). Although a limitation of the study was that these analyses were performed only in mitochondria of non-survivors, abnormalities in mitochondrial ultrastructure were seen in 9% of patients that received intensive insulin therapy *versus* 78% of patients that received conventional therapy. Furthermore, the intensive insulin therapy group had 89% and 40% higher median activities of MMCs I and IV, respectively. The discrepancy in effects on liver and muscle mitochondria was hypothesised to be due to different mechanisms of glucose uptake in these organs and suggested that it was hyperglycaemia, rather than a direct effect of insulin, that led to the aforementioned effects (Vanhorebeek *et al.*, 2005).

1.4.4 Mitochondrial function in fasting

Although a number of investigators have examined the effects of fasting on animal mitochondrial function, this has been within the context of organ transplantation and the associated ischaemia-reperfusion injury. Using a murine model, Jung and Henke (Jung and Henke, 1993) demonstrated impaired liver mitochondrial respiration following 4 days of fasting although this was not associated with decreased energy production (quantified by mitochondrial concentrations of adenine nucleotide).

A study of the effects of nutritional status on rat liver mitochondria demonstrated interesting findings in the control group (Vendemiale *et al.*, 2001). Mitochondria isolated from rats with normal livers that were fasted for 18 hours had greater levels of oxidised lipids and lower concentrations of the ATP synthase complex than their fed counterparts. These changes suggested that fasting directly caused oxidative injury and decreased mitochondrial ATP synthetic capacity. A decrease in mitochondrial ATPase activity, associated with a trend towards lower ATP concentrations, was noted in another study of orthotopic pig liver transplants following 5 days of fasting (Fukumori *et al.*, 1997). However, in this small study (N=5 in each group) the control group was fasted for 24 hours thus the effects of feeding, as opposed to fasting, on mitochondrial function remain unclear.

A previous group studied the effects of fasting on oxidative balance in mitochondria isolated from rat livers in a model of partial hepatic ischaemia-reperfusion injury (Domenicali *et al.*, 2001). Under baseline conditions, 18 and 36-hour periods of fasting progressively depleted mitochondrial antioxidant stores (glutathione) leading to increased lipid peroxidation. As glutathione stores function as cysteine reservoirs, the former are depleted during food deprivation (Cho *et al.*, 1981). Fasting also exacerbated mitochondrial oxidative damage associated with warm ischaemia-reperfusion injury and this effect was dependent on the duration of food deprivation (Domenicali *et al.*, 2001). Finally, transmission electron microscopy demonstrated mitochondrial swelling and ultrastructural abnormalities during post-ischaemic reperfusion in fasted rats

thus providing indirect evidence of membrane injury and mitochondrial dysfunction (Domenicali et al., 2001). A study designed to examine the effects of fasting on oxidative stress in rat liver mitochondria reported similar findings (Sorensen *et al.*, 2006). Compared with overnight fasting in the control group, mitochondria of rats fasted for 72 hours showed significantly increased oxidative and lipoxidative protein damage (levels of N-malondialdehyde lysine, amino adipic semialdehyde and glutamic semialdehyde in mitochondrial proteins of rat liver). Fasting also modified the fatty acid composition of mitochondrial membranes. The aforementioned findings suggest that fasting *per se* adversely affects mitochondrial function through increased oxidative stress and generation of ROS. These in turn alter the lipid and protein composition of mitochondria leading to structural (Domenicali et al., 2001) and functional abnormalities (Sorensen et al., 2006).

A previous study investigated the effects of reduced energy intake on the activities of muscle MMCs I to IV and peripheral blood mononuclear cells (PBMC) MMC I in rats fed enterally (Briet and Jeejeebhoy, 2001). Compared with normally fed rats, one week of protein-energy deprivation significantly reduced the activities of complexes I (-73%), II (-68%) and III (-92%) in the mitochondria of soleus muscle and complex I (-74%) in the mitochondria of PBMC. An important finding in this study was that the activity of MMC I in PBMC was found to correlate with the activity of MMC I in muscle ($r^2=0.66$). The reduction in mitochondrial enzyme activities during protein-energy restriction was hypothesised (Briet and Jeejeebhoy, 2001) to explain findings of decreased

oxygen uptake, substrate oxidation and ADP phosphorylation noted in previous studies of the effects of reduced energy intake on oxidative phosphorylation by liver and muscle mitochondria (Ferreira and Gil, 1984; Ardawi *et al.*, 1989). This hypothesis was subsequently proven in a study of the effects of reduced energy intake on mitochondrial function, where decreased activity of complexes I (approximately -57%) and III (approximately -51%) correlated with a reduction (approximately -57%) in oxidative phosphorylation rate in rat muscle mitochondria (Madapallimattam *et al.*, 2002). Studies of human PBMC MMC activity similarly demonstrated reduced complex I activity in malnourished patients compared to controls (Briet *et al.*, 2003a; Briet *et al.*, 2004). However, the effects of fasting on mitochondrial oxidative phosphorylation remain unclear as the aforementioned studies were performed in animals and malnourished patients who were receiving some energy, albeit not enough to meet daily requirements.

There are no reported human studies on the effects of preoperative fasting on perioperative mitochondrial function, the majority being studies on mitochondrial function within the context of insulin resistant states such as type 2 diabetes and obesity. However, given that fasting induces a state of insulin resistance, valuable insights into the effects of fasting may be gained from these studies. Fasting (Frayn, 1999; Tsintzas *et al.*, 2006) and other states of insulin resistance (McGarry, 2002) are associated with elevation in the plasma concentration of NEFA. Elevated NEFA concentrations result in increased fatty acid flux through skeletal muscle mitochondria which results in reduced

mitochondrial oxidative phosphorylation (Sparks *et al.*, 2005), increased ROS generation (Jackson *et al.*, 2002) and subsequent mitochondrial dysfunction (Sparks *et al.*, 2005). In a study that examined the effects of eating a high fat diet in humans and mice, the increased flux of fatty acids through muscle was found to down regulate genes that encoded mitochondrial proteins and transcription factors involved in mitochondrial biogenesis [the process by which mitochondria increase their ability to make ATP by synthesizing additional enzyme complexes] (Sparks *et al.*, 2005). Interestingly, a similar pattern of gene expression to that seen after intake of a high fat diet was induced by short-term fasting in other studies (Jagoe *et al.*, 2002; Sparks *et al.*, 2005). Furthermore, these changes became more pronounced with increasing length of food deprivation. These results may explain the significant fasting-induced decrease in mitochondrial protein content noted in earlier studies (Brady and Hoppel, 1983).

Recent studies have also characterised the effects of insulin on skeletal muscle mitochondrial function (Boirie, 2003). Insulin was found to stimulate mitochondrial protein synthesis (Boirie *et al.*, 2001), activate mitochondrial enzyme activity (Boirie *et al.*, 2001) and stimulate oxidative phosphorylation by increasing mitochondrial mRNA transcript expression, protein synthesis, activities of cytochrome C oxidase and citrate synthase, and ATP production (Stump *et al.*, 2003). Given these findings, it may be hypothesised that a reduction in insulin concentration and an increase in NEFA concentration, as seen in fasting (Tsintzas *et al.*, 2006), leads to reduced mitochondrial function and oxidative capacity (Figure 1.4).

1.4.5 Perioperative mitochondrial dysfunction

A study that examined the effects of surgery and anaesthesia on mitochondrial function in lymphocytes from 16 patients undergoing major abdominal surgery (Delogu et al., 2001b), demonstrated a significant increase in mitochondrial ROS production coupled with a significant depletion (-24%) of mitochondrial antioxidant (glutathione) stores. These changes in mitochondrial function, although transient, were associated with a significant increase in the rate of apoptosis amongst CD4⁺ and CD8⁺ lymphocytes. Similar findings were noted by the same group in a study on perioperative polymorphonuclear neutrophil mitochondrial function (Delogu *et al.*, 2001a). These studies suggest that an increase in mitochondrial oxidative stress during the perioperative period may play a role in mediating the immune suppression that is seen after surgery (Delogu et al., 2001b). Although mitochondrial dysfunction in this setting may increase the risks of infective complications (Delogu et al., 2001b), the contribution of various confounding factors such as fasting, insulin resistance (Ritz and Berrut, 2005) and anaesthesia (Miro *et al.*, 1999) to this impairment in function was, unfortunately, not studied.

1.4.6 Effects of carbohydrate loading on mitochondrial function

The effects of preoperative conditioning using carbohydrate-based drinks on mitochondrial function have not been studied. Hayakawa *et al.* (Hayakawa *et al.*,

2000) examined the effects of intraoperative glucose infusions on hepatic mitochondrial energy status (redox state) in 26 patients undergoing elective total gastrectomy for cancer. Although their study was weakened because the control group also received intraoperative glucose infusion and the authors used an indirect measure of hepatic mitochondrial energy status (the arterial ketone body ratio), they appeared to show that low mitochondrial energy status accompanied preoperative fasting and that this may be improved with intraoperative glucose infusion. Animal (Briet and Jeejeebhoy, 2001) and human (Briet et al., 2003; Briet et al., 2004) studies on the effects of energy deprivation and malnutrition on MMC activity have demonstrated that short-term refeeding (1 day in rats, 7 days in humans) restored mitochondrial activity. Although a 7-day period of refeeding increased human PBMC MMC I activity (Briet *et al.*, 2003a), normal levels were only attained after one month of refeeding (Briet et al., 2004). The heterogeneity of conditions causing malnutrition in these studies make it difficult, however, to derive any conclusions regarding the possible protective effects of preoperative carbohydrate loading in healthy patients undergoing elective surgery.

1.5 Conclusions

The mechanisms that underlie the development of perioperative insulin resistance during fasting and its attenuation by preoperative carbohydrate drinks are yet to be defined. Animal studies have shown that energy deprivation has

adverse effects on mitochondrial function by decreasing mitochondrial ATP synthesis capacity and complex activity, and increasing oxidative injury. Furthermore, evidence from human studies suggests that the development of insulin resistance during fasting may be linked to impaired mitochondrial function. Future studies should investigate whether mitochondrial dysfunction underlies the development of insulin resistance in healthy patients undergoing elective surgery.

Chapter 2
Hypotheses

As previously discussed, the cellular mechanisms underlying the development and attenuation of insulin resistance following short-term fasting and preoperative conditioning with carbohydrate-based drinks, respectively, are yet to be defined. The forthcoming studies hypothesised that:

- A) Short-term fasting (up to 24 hours) fasting would deplete glycogen reserves, impair mitochondrial function and alter the expression of key metabolic genes and proteins (PDK4, FOXO1, Mt-1A) involved in the pathways leading to the development of insulin resistance;
- B) 'Preoperative' ingestion of a carbohydrate-based drink [Oral Nutritional Supplement (ONS), Fresenius Kabi, Germany), that also contained glutamine and antioxidants, designed to improve perioperative metabolic function, would reverse the aforementioned deleterious effects of short-term fasting.

The rationale underlying the drink (ONS) containing glutamine and antioxidants, in addition to carbohydrate, was that these ingredients may provide benefits in addition to those provided by carbohydrate loading alone (Houdijk et al., 1998; Jones et al., 1999; Baines and Shenkin, 2002; Henriksen et al., 2003; Bakalar et al., 2006; Dechelotte et al., 2006). It was hypothesised that:

- C) Preoperative ingestion of ONS would be safe and well tolerated in patients undergoing laparoscopic cholecystectomy;
- D) The additional constituents (glutamine and antioxidants) would be absorbed and lead to increased perioperative plasma concentrations.

A previous study of healthy volunteers (Lobo *et al.*, 2009, *vide infra*) has demonstrated markedly differing gastric emptying times following ingestion of ONS and a preoperative clear carbohydrate drink (preOp®, Nutricia Clinical Care, UK). Whilst the mean (95% CI) T_{100} of 400 ml of preOp® was 94 (79-110) min, that of the same volume of ONS was 156 (138-173) min. It was hypothesised that:

- E) Ingestion of preOp® and ONS would lead to differing postprandial metabolic (glucose, NEFA, OHB and glutamine) and hormonal (insulin and glucagon) responses.

Finally, glutamine supplementation of preoperative carbohydrate-based drinks is thought to delay gastric emptying, as a result of increased glucagon-like peptide 1 (GLP-1) release, the latter an incretin previously shown to delay gastric emptying (Reimann *et al.*, 2004; Karamanlis *et al.*, 2007; Greenfield *et al.*, 2009). Furthermore, the addition of lipid to liquid carbohydrate meals is thought to result in delayed gastric emptying (Houghton *et al.*, 1990) and blunted postprandial glucose and insulin responses (Welch *et al.*, 1987). It was hypothesised that:

- F) The gastric emptying times of the preoperative carbohydrate drink (preOp®) would be increased by the addition of either glutamine or lipid, the lipid based drink being utilised as a 'positive' control for a drink that

results in delayed gastric emptying, these effects a consequence of differing GLP-1 responses.

Chapter 3

Common methods

3.1 Approvals from regulatory bodies

Ethical approval for these studies was obtained from the University of Nottingham Medical School Research Ethics Committee (studies in Chapters 4 and 6), the Nottingham Research Ethics Committee 1 (study in Chapter 5) and the Leicestershire, Northamptonshire and Rutland Research Ethics Committee 2 (study in Chapter 7). The respective approval numbers for these studies were as follows: Chapter 4 (C/12/2007), Chapter 5 (08/H0403/18), Chapter 6 (B/12/2008) and Chapter 7 (09/H0402/73). Additional approval for the administration of radioactive substances was obtained from the Administration of Radioactive Substances Advisory Committee of the UK Department of Health (253/2416/24 345) for the study in Chapter 7. The respective Research and Development approval numbers for the studies in Chapters 4, 5, 6 and 7 were 07GA011, 07GA010, 09GA001 and 09GA002. The studies in Chapters 5, 6 and 7 were registered at clinicaltrials.gov (NCT00662376, NCT00909701, NCT00943020). All studies were performed in accordance with the Declaration of Helsinki of the World Medical Association.

3.2 Eligibility and exclusion criteria for healthy volunteer studies (Chapters 4, 6 and 7)

In the studies detailed in Chapters 4, 6 and 7 healthy male Caucasian volunteers (aged 18-45 yrs) with a BMI of 20-25 kg/m² and no history of abdominal surgery

or gastrointestinal disorders were studied. Subjects were excluded if they smoked or had a family/personal history of diabetes mellitus or other metabolic disorders.

3.3 Randomisation and blinding

In these studies the computer-generated randomisation codes were performed. Allocations were concealed in sequentially numbered sealed opaque envelopes and were opened before each arm of the study by a person not involved with the study. All study personnel and participants were blinded to treatment assignments. The randomisation codes were revealed once data collection, laboratory and statistical analyses were complete.

3.4 Collection of blood samples

Blood was sampled either by venepuncture or via a 19 G venous cannula (Venflon®, Ohmeda, Sweden) into the appropriate Vacutainer® blood collection tube (Becton Dickinson & Co, UK). In the studies detailed in Chapters 6 and 7, arterialised venous blood was sampled by the heated-hand technique as previously described (Brooks *et al.*, 1989). In brief, a retrograde venous cannula was sited into the dorsum of the hand which was placed into a hand warmer (55°C) for at least 15 min prior to each blood sampling time point. As was

standard practice in our laboratory, we did not measure the temperature of the heated hand placed inside the 'hot-box'.

3.5 Analysis of blood samples

All assays were performed by trained laboratory staff using standard operating procedures and calibrated equipment. The following assays were performed by staff at the HPLC laboratory of the Metabolic Physiology Group, School of Biomedical Sciences, University of Nottingham: insulin, glucagon, NEFA (Chapters 5 & 6), β -hydroxybutyrate (OHB, Chapter 6) and glucagon-like peptide 1 (GLP-1).

The following assays were performed by laboratory staff at the Department of Pathology, Nottingham University Hospitals NHS Trust: full blood count (FBC), clotting profile, urea and electrolytes (U&E), C-reactive protein (CRP), liver enzymes, lipid profile, NEFA (Chapter 4), OHB (Chapter 4) and glucose (Chapters 4 and 5).

Measurements of plasma concentrations of vitamin A, C, E, selenium, zinc and plasma amino acids were performed by laboratory staff at the Institut für Ernährungs- und Lebensmittelwissenschaften, University of Bonn, Germany.

In the studies described in Chapters 6 and 7 blood glucose was measured using the HemoCue® glucose analyzer (HemoCue Ltd., Ängelholm, Sweden).

3.5.1 Insulin assays

Serum insulin was measured using a solid-phase ^{125}I radioimmunoassay (Coat-a-count insulin kit, Siemens Medical Solutions Diagnostics, Camberley, UK). The interassay coefficient of variation for this assay was 6.3%.

3.5.2 Glucagon assays

Blood samples for glucagon were treated with aprotinin (500 KIU/ml blood, Bayer HealthCare, Morristown, NJ, USA) and stored in glass tubes at -80°C until analysis. Total pancreatic glucagon concentrations were determined using solid-phase ^{125}I radioimmunoassays (Double Antibody Glucagon kit, Siemens Medical Solutions Diagnostics, Camberley, UK). The interassay coefficient of variation for this assay was 4.4%.

3.5.3 Nonesterified/free fatty acid assays

Serum NEFA/FFA were measured using an automated immunoassay analyser (Olympus AU5400) and a commercially available kit (Randox® kit NEFA RB1007, County Antrim, UK). The interassay coefficient of variation for this assay was 3.5%.

3.5.4 β -hydroxybutyrate assays

Serum OHB were measured using an automated immunoassay analyser (Olympus AU5400) and a commercially available kit (Randox® kit OHBUT FA115, County Antrim, UK). The interassay coefficient of variation for this assay was 3.5%.

3.5.5 Glucagon-like peptide 1 assay

Blood (2 ml) for GLP-1 was collected into ice-cooled EDTA tubes and immediately treated with 20 μ l dipeptidyl peptidase IV inhibitor (Millipore, Watford, London, UK). After centrifuging at 2000 x *g* for 10 min (4°C) plasma was collected and frozen at -80°C until analysis. GLP-1 concentrations were determined using a commercially available kit (GLP-1 [Active] RIA Kit, Linco Research, St. Charles, Missouri, USA). The interassay coefficient of variation for this assay was 4.5%.

3.5.6 Vitamin assays

Plasma vitamin concentrations were determined by high performance liquid chromatography (HPLC) as previously described {Erhardt, 1999 #572;Furst, 1990 #463}.

3.5.7 Trace element assays

Trace element concentrations were determined by atomic absorption spectroscopy.

3.5.8 Amino acid assays

Plasma amino acid concentrations were determined by reversed phase HPLC as previously described (Furst et al., 1990). The interassay coefficient of variation for the glutamine assay was 3.7%.

3.6 Protein concentrations

Protein concentrations were determined in the mitochondrial and enzyme suspensions using the Bradford dye-binding (Bio-Rad) protein assay (Bradford, 1976). This colorimetric assay involves the addition of an acidic dye (Coomassie® Brilliant Blue G-250) to protein solution and subsequent measurement at 595 nm with a plate reader (Molecular Devices SpectraMaxi 190). Ten dilutions (1 to 10 µg/ml) of Bovine Serum Albumin (0.01% BSA) protein standards were prepared in Eppendorf microtubes. Samples for protein measurement were diluted x 10 with distilled water. 400 µl of each standard and sample solution (the latter in duplicate) were pipetted into a microtube to which was added 100 µl of dye reagent concentrate followed by a brief vortex. Samples were incubated at room

temperature for at least 5 min, followed by transfer of 200 μ l from each microtube mix to a microtitre plate for measuring absorbance.

3.7 Composition of study drinks

The constituents and physical properties of the study drinks [Nutricia preOp® (Nutricia Clinical Care, UK) and Oral Nutritional Supplement (ONS, Fresenius Kabi, Germany)] investigated in studies outlined in Chapters 5, 6 and 7 are listed in Table 3.1 below:

Table 3.1: Constituents and physical properties of the study drinks used in studies outlined in Chapters 4 and 6.

	Nutricia preOp®	ONS (70 g powder reconstituted with water to a total volume of 400 ml)
Volume	400 ml	400 ml
Carbohydrate	50.4 g Maltodextrin + fructose	50 g Maltodextrin + saccharose + modified starch + gum arabic
Glutamine	-	15 g
Vitamin C	-	750 mg
Vitamin E	-	250 mg
Green tea extract	-	1 g
β-carotene	-	5 mg
Zinc	-	10 mg
Selenium	-	150 µg
Fat	-	0.218 g
Energy	200 kcal (836 kJ)	234 kcal (978 kJ)
Dry matter content	11.3%	16.3%
pH	4.9	3.9
Density	1.05 g/l	1.06 g/l
Osmolarity	228 mOsm/kg	508 mOsm/kg

In the randomised double-blind studies described in this thesis, the study drinks were reconstituted (ONS) or prepared (preOp®) by a person not involved in the studies and served to the study subjects in identical opaque bottles.

3.8 Statistical analyses

Statistical analysis was performed with SPSS® for Windows™ v16 software (SPSS Inc, Chicago, IL, USA). The Shapiro-Wilkes test was used to determine normality of distribution. Data are presented as mean (SE or 95% CI) or median (IQR) as appropriate. The paired and independent samples t-tests were used for parametric paired and unpaired data, respectively. The Wilcoxon signed rank and Mann-Whitney U tests were used for non-parametrically distributed paired and unpaired data, respectively. The Chi square test was used for categorical data. Comparisons between the study time points for parametric and non-parametric data were made using the repeated measures (one-way, two-way or three-way as appropriate) ANOVA or the Kruskal Wallis tests, respectively. The appropriate post-hoc test (paired t-test or Wilcoxon signed rank test) was used to locate any differences. Two-tailed *P*-values, unadjusted for multiple testing, are reported and differences were considered significant at $P < 0.050$.

3.9 Funding for studies

The studies in this thesis were supported by the following grants:

The Royal College of Surgeons of England one-year research fellowship (supported by the Doris Mary Sheppard Legacy and Rosetrees Trust), the Mason Medical Research Foundation and the Enhanced Recovery After Surgery Group (via an unrestricted educational grant from Fresenius Kabi). The funders of these studies had no role in the design and execution of the studies, data analysis, writing or decision to submit the manuscripts for publication.

Chapter 4

The effects of fasting and refeeding with a 'metabolic preconditioning' drink on substrate reserves and mononuclear cell mitochondrial function

Magnetic resonance spectroscopy (MRS) allows the *in vivo* assessment of glycogen and lipid levels using naturally abundant ^{13}C and ^1H nuclei, thereby enabling studies of energy metabolism (Morris *et al.*, 1994; Krssak *et al.*, 2000).

4.1 Aims

The aims of this study were two-fold:

- A) To study the dynamic changes in substrate metabolism and reserves following short-term fasting (24 hours) and refeeding with ONS, and
- B) To determine whether mononuclear cell mitochondrial function is altered by this period of fasting/refeeding.

4.2 Methods

4.2.1 Interventions

After recruitment volunteers completed a 3-day food diary which was used to standardise the meal given at the commencement of the study. Volunteers abstained from alcohol and caffeine for 24 hours, and from strenuous exercise for 3 days prior to the study. Throughout the study the volunteers were asked to rest, drink water *ad libitum*, and were transported to the study sites by taxi to eliminate the possible confounding effect of exercise.

4.2.2 Standardised meal and ONS

The aim of the standardised mixed-meal was to load liver and muscle glycogen reserves thus representing the baseline 'fed' state. Microdiet® (Downlee Systems Ltd., Highpeak, UK) software was used to alter the quantities of the meal constituents to provide 40% of the volunteers' daily energy intake with a macronutrient energy contribution of 50% from carbohydrate, 35% from fat and 15% from protein. Volunteers consumed the meal within 15 min and time 0 was defined as the end of the meal. Two servings of the study drink (ONS) were reconstituted from powdered form into a suspension (400 ml) using bottled water.

4.2.3 Study protocol

Volunteers reported for the study at 0745 hours after a 12-hour fast. Height, weight and body mass index (BMI) were recorded and the fast commenced after ingestion of the standard meal (Figure 4.1).

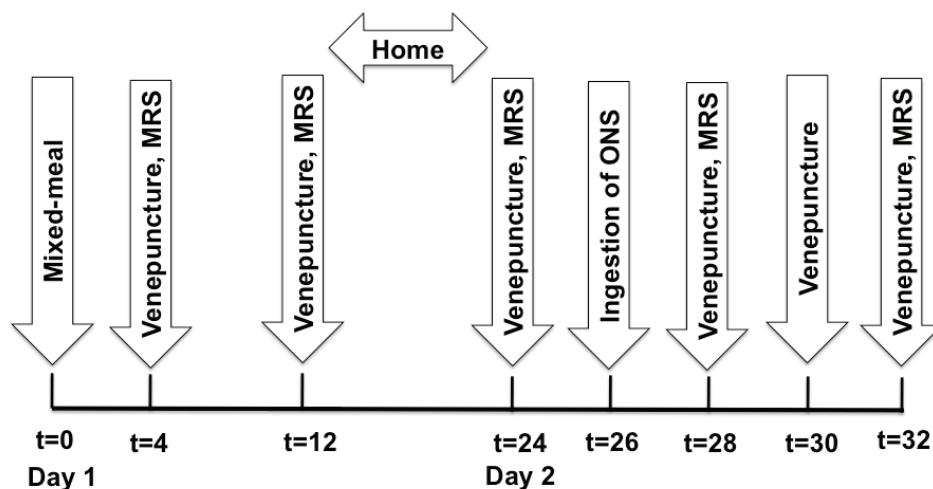

Figure 4.1: Experimental protocol. The baseline ‘fed’ state was studied 4 hours after ingestion of a standardized mixed-meal. At 4, 12, and 24 hours venepuncture was performed and magnetic resonance spectroscopy (MRS) performed. Subjects ingested the study drink (ONS) at 26 hours following which venepuncture and MRS were repeated at 2 and 6 hours postprandially.

After 4 hours blood was sampled by venepuncture and MRS scans were performed to study the subjects in the baseline ‘fed’ state. The 4-hour time point was chosen given that the mean (95% CI) T_{100} gastric emptying time of ONS was 156 (138-174) min (Lobo et al., 2009) and that previous studies have demonstrated maximal postprandial increases in liver glycogen within 4-6 hours of ingestion of a mixed-meal (Taylor *et al.*, 1996; Carey *et al.*, 2003). Blood sampling and MRS scanning were repeated after 12 hours of fasting following

which the volunteers were allowed home with instructions to remain fasted. Blood sampling and MRS scanning were repeated after 24 hours of fasting had elapsed. Volunteers then ingested ONS (within 5 min) following which blood samples were obtained and MRS scans performed at 2 and 6 hours postprandially. The aforementioned measurements were selected to allow a fuller study of the *in vivo* metabolic changes following fasting and refeeding.

4.2.4 Magnetic resonance techniques

Nuclear magnetic resonance (NMR) has been widely applied to metabolic studies *in vivo*. It relies on the magnetic properties of nuclei which have a net spin by virtue of the spins of their constituent protons and neutrons (Morris et al., 1994). NMR involves the interaction of nuclear spins with a static magnetic field and has the unique ability to differentiate between different metabolites due to 'chemical shift'. The resonance frequency of the signal produced is distinct for nuclei in different chemical environments, enabling individual structures to be distinguished. The strength of the NMR signal (the area under a peak in the NMR spectrum) is proportional to the number of spins contributing to it (Morris et al., 1994). The wide chemical shift range (>200 ppm) of the ^{13}C nucleus permits metabolites to be identified directly and unambiguously from their ^{13}C NMR spectra (Morris et al., 1994). The low natural abundance (1.1%) of the stable isotope ^{13}C means that only metabolites such as glycogen, that is highly concentrated in tissues such as liver and muscle, can be directly observed at

natural abundance in vivo (Alger *et al.*, 1981). Despite the ubiquitous presence of the proton, the development of high-field instrumentation and water suppression techniques has permitted the widespread use of ^1H NMR in the study of lipid metabolism (Morris *et al.*, 1994).

MRS was performed on a Philips 3T system at the Sir Peter Mansfield Magnetic Resonance Centre, School of Physics and Astronomy, University Campus. The MRS scans were performed by the following collaborators: Miss Mary Stephenson (PhD student, School of Physics and Astronomy), Miss Elisa Placidi (PhD student, School of Physics and Astronomy) and Dr. Luca Marciani (Senior RCUK Academic Fellow, Nottingham Digestive Diseases Centre NIHR Biomedical Research Unit). A transmit/receive body coil was used for ^1H imaging and MRS for measurements of liver volume and hepatic and skeletal muscle (soleus) lipid concentrations, respectively. A 14 cm ^{13}C surface probe with quadrature proton decouple coils was used for measurement of hepatic and calf (gastrocnemius) muscle glycogen. We studied the gastrocnemius muscle, in line with previous investigators (Carey *et al.*, 2003), as the positioning and aligning of the lower leg and calf on the ^{13}C coil was easier and more reproducible than placing the coil on top of the thigh quadriceps muscle. Liver volumes were measured using T1-weighted, breath-hold turbo field echo scan with resolution $2\times 2\times 7\text{ mm}^3$, 36 slices, matrix 180×182 , TR = 3.11ms, total scan time 14.4s. The images were analysed by drawing regions of interest in Analyze6 (Biomedical Imaging Resources, Rochester, MN) and values are reported as volume (litres) and % change from baseline. The coefficient of variation (CV) for repeated

measurement of liver volume was 0.8%. Hepatic ^1H spectra were acquired from a $30\times 30\times 30$ mm voxel positioned in the right lobe using a respiratory triggered PRESS sequence and the following parameters: echo/repetition time 40/5000 ms, 16 averages, bandwidth 2000 Hz, 1024 samples. Two ^1H spectra were acquired in muscle: water-suppressed for intramyocellular lipid (IMCL, 32 averages) and non water-suppressed for total calf lipid (16 averages). PRESS localization was used with echo/repetition time 40/7000 ms, voxel $30\times 30\times 50$ mm, bandwidth 2000 Hz, 1024 samples. ^1H non water-suppressed spectra were post-processed using jMRUI and peak areas were calculated using in-house software built in Matlab®. Water suppressed spectra were analysed using the AMARES algorithm (Vanhamme *et al.*, 1997) in jMRUI, fitting to Gaussian lineshapes. Lipid values are reported as % change from baseline. The CV for repeated measurements of liver lipid, IMCL and extramyocellular lipid (EMCL) concentrations were 4%, 6% and 21%, respectively. The EMCL CV was higher than that for IMCL as the content of extramyocellular lipid is more variable and more dependent on the positioning of the voxel. ^{13}C spectra (Figure 4.2) were acquired using a proton-decoupled pulse acquire sequence with bandwidth 7000Hz, 512 samples, ^{13}C adiabatic pulses and narrowband decoupling (3 spectra with repetition time 2150 ms, 288 averages, total duration 30 min for the liver and 2 spectra with repetition time 1300 ms, 336 averages, duration 15 min for the calf). jMRUI was used for post-processing and peak areas were determined using in-house software built in Matlab®. Spectral peaks were selected using the AMARES algorithm and were fitted to Lorentzian lineshapes. The integral of the

glycogen peak was expressed as a fraction of the formate peak derived from a phantom containing formate placed at the centre of the ^{13}C coil. Quantification of glycogen concentrations was performed using a phantom replacement method (Leverton, 2009). In brief, a cylindrical phantom containing a known glycogen concentration was placed at various distances from the coil and images and spectra were acquired for each position. The images were used to identify pixels corresponding to the phantom and those corresponding to the marker at the centre of the coil. These were then used to find a relationship between the distance between glycogen containing pixels, the coil and the size of the resulting glycogen signal. The same was performed for the *in vivo* images thus producing scaling factors for the subjects and phantoms which were used for quantification. The subject glycogen concentrations were calculated using the following equation:

$$[\text{Subject}] = \frac{S_{\text{glycogen}}/S_{\text{formate}}}{\left[\frac{P_{\text{glycogen}}/P_{\text{formate}}}{[\text{Phantom}] \text{ scale}_{\text{phantom}}} \right] \text{ scale}_{\text{subject}}}$$

Where

[Subject] = the glycogen concentration in the subject,

[Phantom] = the glycogen concentration in the phantom,

S_{glycogen} = the integral of the NMR peak from the subject due to glycogen,

S_{formate} = the integral of the NMR peak from the subject due to formate marker,

P_{glycogen} = the integral of the NMR peak from the phantom due to glycogen,

P_{formate} = the integral of the NMR peak from the phantom due to formate marker,

$\text{Scale}_{\text{subject}}$ = scaling factor for the subject,

$\text{Scale}_{\text{phantom}}$ = scaling factor for the phantom.

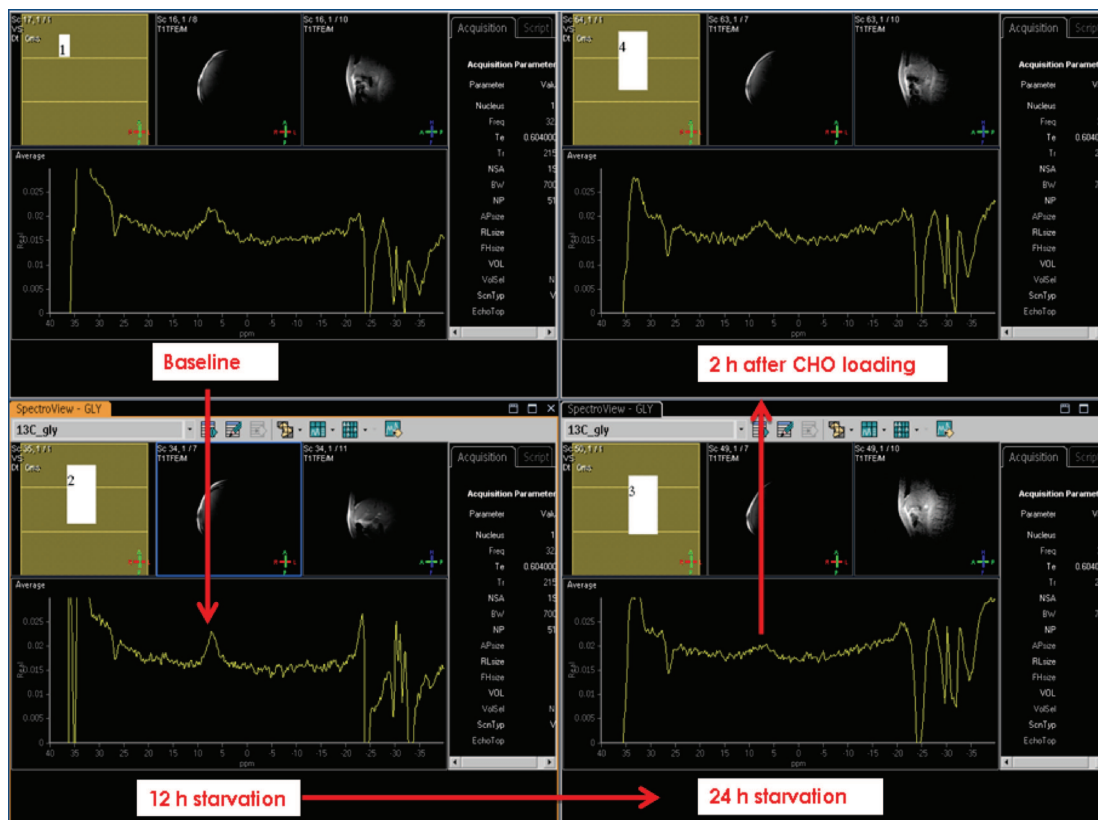

Figure 4.2: Example of the dynamic changes in ^{13}C (used to calculate glycogen concentrations), during the course of the study, as determined by magnetic resonance spectroscopy. ‘Baseline’ scan was performed 4 hours after the standardised mixed-meal. The subsequent scans were performed after 12 and 24 hours of fasting (decreased area under ^{13}C peak) and 2 hours following ingestion of the carbohydrate-based study drink (ONS).

Liver glycogen is reported in mmol and as % change from baseline. Muscle glycogen is reported as % change from baseline. The CV for repeated measurements of liver and muscle glycogen were 14% and 11% respectively. Magnetic resonance spectra were blinded prior to analysis to avoid operator bias.

4.1.5 Sampling of blood samples

The following analyses were performed on blood sampled at the baseline 'fed' state, following 12 and 24 hours of fasting and 4 hours after ONS ingestion: FBC, U&E, liver enzymes, glucose, insulin, NEFA, OHB, CRP, clotting and lipid profiles. Additional blood samples were taken at 2 and 6 hours following ONS intake for analysis of blood glucose, insulin, NEFA and OHB concentrations to allow more detailed study of changes in intermediary metabolism.

4.2.6 Preparation of mononuclear cells

Mononuclear cells (MNC) were isolated from 20 ml of venous blood by density gradient centrifugation (Boyum, 1968) and following the Histopaque®-1077 (Sigma-Aldrich, Dorset, UK) manufacturer's guidelines (Procedure No. 1077). Blood was collected into BD® heparin vacutainers following which it was diluted volume for volume with pre-prepared phosphate buffered saline (PBS) solution [1 PBS tablet dissolved in 100 ml distilled water, then sterilised and filtered using a

vacuum driven disposable filtration system (Stericup®, Millipore Ltd., Watford, UK) into a 50 ml centrifuge tube (Greiner Bio-One GmbH, Frickenhausen, Germany)] and mixed by gentle agitation. Seven ml of Histopaque®-1077 (Sigma-Aldrich, Dorset, UK) were aliquoted into 15 ml centrifuge tubes. An equivalent volume of diluted blood (7 ml) was gently layered onto the Histopaque® by tilting the 15 ml centrifuge tube to 45° (Figure 4.3).

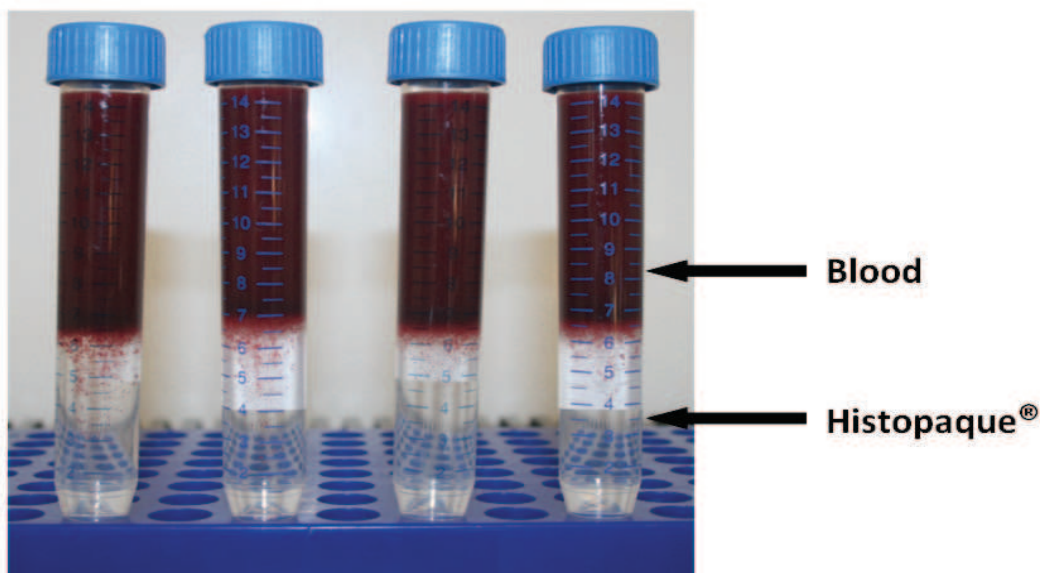

Figure 4.3: Appearance of peripheral blood layered onto Histopaque® in 5 ml centrifuge tubes.

The centrifuge tubes containing the blood/Histopaque® mixture were centrifuged (MSE Harrier 15/80) at 400 x *g* for 30 min at room temperature. The centrifuge tubes were carefully removed taking care not to agitate the buffy coat (Figure 4.4).

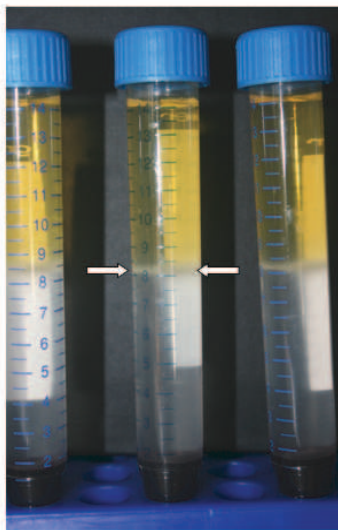

Figure 4.4: Appearance of the buffy coat (arrows) following centrifugation of blood layered onto Histopaque® at 400 x *g* for 30 min at room temperature.

The excess plasma was removed from each centrifuge tube to within 5 mm above the buffy coat and discarded. A 10 ml serological pipette (Greiner Bio-One, GmbH, Frickenhausen, Germany) was used to aspirate the buffy coat of mononuclear cells (MNC) and decant into a new 50 ml centrifuge tube. RPMI-1640 (Sigma, Dorset, UK) was added to the MNC to make up to a total volume of 50 ml and mixed by gentle agitation. The 50 ml centrifuge tube was centrifuged (Eppendorf 5702R) at 250 x *g* for 10 min at room temperature. The centrifuge tube was carefully removed ensuring that the resultant pellet of MNC is not agitated. The supernatant was discarded leaving the MNC pellet at the base of the centrifuge tube (Figure 4.5).

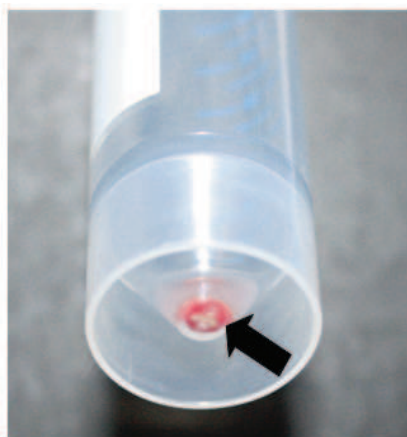

Figure 4.5: Appearance of the MNC pellet (arrow) following centrifugation at 250 x *g* for 10 min at room temperature and removal of the supernatant.

The pellet was washed 3 times with RPMI then added to cryovials (Alpha Laboratories, Hampshire, UK) containing a cryoprotectant mix (20% fetal bovine serum (Sigma, Dorset, UK), 10% dimethyl sulphoxide hybri-max (Sigma, Dorset, UK) and RPMI-1640 (Sigma, Dorset, UK) and placed in a cryogenic freezing container (Nalgene, Hereford, UK). The inner chamber of the latter was filled with HPLC grade Propanol-2 (Fisher Scientific, Loughborough, UK) and placed in a -80°C freezer for at least 24 hours to ensure gentle freezing of the MNC. The cryovials were then transferred from the cryogenic freezing container into standard cryovial storage containers and frozen at -80°C for future analyses. As we planned to lyse the MNC pellets, thereby extracting the mitochondrial fraction, we did not seek to assess the 'purity' of the isolated MNC.

The MNC were later defrosted by agitating in a water bath at 37°C. Twenty ml of RPMI-1640 (Sigma, Dorset, UK) were added and the suspension centrifuged at $1000 \times g$ for 10 min at room temperature. The resultant pellet was resuspended in RPMI and washed 2 further times. The MNC pellet was resuspended in 1 ml of phosphate buffered saline (PBS, 20 mmol/L, pH 7.2) and sonicated for 20 s (4 bursts of 5 s each, with a 30 s break between each burst) on ice to isolate the mitochondrial fraction (Martin *et al.*, 1996). Homogenates were centrifuged at $10\ 000 \times g$ for 3 min at 4°C, the supernatant discarded and the resultant mitochondrial pellet resuspended in 100 µl of PBS and placed on ice.

4.2.7 Enzyme assays

4.2.7.1 Protein concentrations

Protein concentrations of the MNC mitochondrial fraction were determined by the Bradford dye-binding (Bio-Rad) assay (section 3.6).

4.2.7.2 Mitochondrial membrane complex activities

In a previous study (Briet and Jeejeebhoy, 2001), MNC mitochondrial complex activity was found to correlate with mitochondrial complex activity in muscle. As such, MNC mitochondrial membrane complex (MMC) activities were used as a surrogate marker of muscle mitochondrial function. Mononuclear cell MMC

activities were measured spectrophotometrically in a plate reader (Molecular Devices SpectraMaxi 190) and the kinetic assays performed in duplicate under conditions of maximal reaction velocity at an optimal pH and at room temperature, as previously described (Wibom *et al.*, 2002). In brief, reagent stock solutions were prepared at the appropriate concentrations and frozen in batches for future use: KH_2PO_4 100mM, MgCl_2 0.5M, oxidized cytochrome C 1.38M, reduced cytochrome C 2mM, Rotenone (saturated in ETOH), Coenzyme Q_1 6mM and 1mM, Succinate 0.5M and DCIP 0.6M. The following reagents were freshly prepared on the day of the experiment: potassium cyanide (KCN) 20mM, Antimycin A 0.6mg/ml and NADH 7.35mM. All reagents were obtained from Sigma (Dorset, UK), Fischer Scientific (Loughborough, UK), Merck (Darmstadt, Germany) and Roche Applied Science (Burgess Hill, UK).

NADH:coenzyme Q reductase (complex I) and NADH:cytochrome C reductase (complex I + III) activities

10 μL frozen mitochondrial suspension were added to 590 μL of a probe solution (pH 7.2) consisting of KH_2PO_4 (5mM), MgCl_2 (5mM) and bovine serum albumin (0.5 g/L) and kept on ice. Within 1 min this was mixed with another 50 μL of the same solution supplemented with saponin (7.15 g/L).

Complex I: 72 μL of probe solution containing mitochondria were incubated for 7 min in a reaction mixture (pH 7.5) with the following final composition: KH_2PO_4

(50mM), $MgCl_2$ (5mM), bovine serum albumin (5 g/L), KCN (0.20mM), antimycin A (1.2 mg/L) and coenzyme Q_1 (0.12mM). NADH was added to a final concentration of 0.15mM and the decrease in absorbance was monitored at 340nm for 1 min before and after the addition of rotenone (2 mg/L). The final volume was 150 μ L. The rotenone-sensitive activity was calculated with the use of an extinction coefficient of 6.81 L/mmol/cm.

Complex I + III: 6 μ L of probe solution containing mitochondria were incubated for 7 min in a reaction mixture (pH 7.5) with the following final composition: KH_2PO_4 (50mM), $MgCl_2$ (5mM), bovine serum albumin (5 g/L), KCN (0.20mM) and oxidized cytochrome C (0.12mM). NADH was added to a final concentration of 0.15 mM and the increase in absorbance was monitored at 550nm for 1 min before and after the addition of rotenone (2 mg/L). The final volume was 125 μ L. The rotenone-sensitive activity was calculated.

Succinate:cytochrome C reductase (Complex II + III) activities:

10 μ L frozen mitochondrial suspension were incubated at 37°C for 30 min in 100 μ L of a solution (pH 7.2) consisting of KH_2PO_4 (50mM), succinate (30mM), $MgCl_2$ (7.5mM) and saponin (0.45 g/L). The blank rate was measured in the reagent (pH 7.5) consisting of KH_2PO_4 (50mM), $MgCl_2$ (5mM), bovine serum albumin (5 g/L), KCN (0.20mM), succinate (30mM), rotenone (2 mg/L) and oxidized cytochrome C (0.12mM). 5 μ L of probe solution containing mitochondria were added and the

enzyme-catalyzed reduction of cytochrome C was monitored at 550nm for 2 min. The final volume was 150 μ L.

Cytochrome C oxidase (complex IV) activity:

10 μ L frozen mitochondrial suspension was diluted to a final volume of 100–300 μ L (i.e. 100 U/L of citrate synthase) in a probe solution (pH 7.5) containing digitonin (1 g/L) and KH_2PO_4 (50mM). The blank rate was recorded in the reagent (pH 7.5) consisting of KH_2PO_4 (50mM), rotenone (2 mg/L) and reduced cytochrome C (0.03mM). 10 μ L of the probe solution containing mitochondria were added and the enzyme-catalyzed oxidation of cytochrome C was followed at 550 nm for 1 min. The final volume was 250 μ L. Reduced cytochrome C was prepared using ascorbate as previously described (Birch-Machin *et al.*, 1994). Citrate synthase (CS) was used as a mitochondrial marker and determined both in muscle tissue and in the mitochondrial suspension according to the principles previously described (Wibom and Hultman, 1990).

In view of the limited quantity of MNC mitochondria isolated, it was only possible to measure the activities of MMC I, II and IV in $N = 7, 12$ and 11 volunteers, respectively. The results were expressed as $\mu\text{mol}/\text{min}/\text{g}$ protein. The CV for the activities of complex I, II and IV assays were 10%, 15% and 12%,

respectively, similar to those reported by other groups (Martin et al., 1996; Briet *et al.*, 2003b).

4.2.8 Statistical analyses

The required sample size to detect a change of 40% in liver glycogen (the primary endpoint) with a power of 90% at the 95% significance level was 12 subjects and was estimated based on the results of a previous study (Casey *et al.*, 2000). Secondary endpoints included muscle glycogen concentrations, liver and muscle lipid concentrations, blood insulin, glucose, NEFA and OHB, and mononuclear cell MMC activity. Statistical analyses aimed to examine the effects on substrate reserves, substrate concentrations and mitochondrial function of: 1) 12 and 24 hour periods of fasting; 2) intake of ONS following a 24 hour fast; and 3) time-related changes following ingestion of ONS. Two-tailed P-values, unadjusted for multiple testing, are reported and differences were considered significant at $P < 0.050$.

4.3 Results

The median (IQR) age and mean (SE) baseline weight, height and BMI of the 12 volunteers were 21 (19-28) yrs, 74 (2.8) kg, 1.79 (0.02) m and 23 (0.62) kg/m² respectively. All subjects completed the study with no reported side effects.

4.3.1 Standardised meal

The mean (SE) reported daily energy intake, calculated from the 3-day food diaries (Appendix A), was 9.5 (0.5) MJ/day and the energy, carbohydrate, fat and protein contents of the standardized meal were 3.8 (0.2) MJ, 119 (6.4) g, 35 (1.9) g and 34 (1.8) g, respectively. The mean (95% CI) energy requirement calculated from the resting metabolic rate (RMR) assuming a light level of activity (1.5 x RMR) was 11305 (10700-11911) kJ/day (Schofield, 1985). The food diaries therefore underestimated daily energy requirements by 16% (Appendix A).

4.3.2 Blood assays

Over the course of the study, the FBC, U&E, liver enzymes, CRP, clotting profile and plasma cholesterol concentration were within the laboratory normal range (data not shown). Changes in insulin, glucose, triglycerides, NEFA and OHB concentrations are shown in Table 4.1.

Table 4.1: The effects of fasting and refeeding with the study drink (ONS) on substrate metabolism. *Serum insulin* – Data are expressed in mIU/L [mean (SE)]. Laboratory normal non-fasting range: 6-25. *Plasma glucose, triglycerides and serum NEFA and OHB concentrations* – Data are expressed in mmol/L [mean (SE)]. Laboratory normal ranges: glucose (fasting): 3.0-6.1; triglycerides (fasting) 0.45-1.81; NEFA (fasting): 0.1-0.9; OHB (fasting): 30-300. ^{†††} $P < 0.001$ indicate significant differences between values after 12 hour fast and those at the baseline 'fed' state. ^{***} $P < 0.001$ indicates significant difference between values after 24 hour fast and those at baseline. [†] $P < 0.05$, ^{††} $P < 0.01$, ^{†††} $P < 0.001$ indicate significant differences in values after 24 hour fast and those after 12 hour fast. ^{§§§} $P < 0.001$ indicates significant difference between values 2 hour after ONS and those after 24 hour fast. [§] $P < 0.05$, ^{§§} $P < 0.01$, ^{§§§} $P < 0.001$ indicate significant difference between values 4 hours after ONS and those after 24 hour fast. [#] $P < 0.05$, ^{##} $P < 0.01$ indicate significant differences between values 6 hours after ONS and those after 24 hour fast.

	Baseline 'fed' state (4 hours after standard meal)	After 12 hour fast	After 24 hour fast	2 hours after study drink	4 hours after study drink	6 hours after study drink
Serum insulin, N = 12	16.0 (2.3)	1.9 (0.4) ⁺⁺⁺	1.3 (0.1) ^{***,†}	32.0 (3.9) ^{§§§}	4.5 (1.1) [§]	1.6 (0.5)
Plasma glucose, N = 12	4.3 (0.16)	4.5 (0.08)	4.2 (0.09) ⁺⁺⁺	6.6 (0.32) ^{§§§}	4.3 (0.21)	4.1 (0.12)
Plasma triglycerides, N = 12	2.03 (0.26)	0.96 (0.10) ⁺⁺⁺	1.17 (0.11) ^{***,††}	0.79 (0.09) ^{§§§}	0.69 (0.07) ^{§§§}	0.94 (0.09) [#]
Serum NEFA, N = 12	0.09 (0.01)	0.67 (0.09) ⁺⁺⁺	0.62 (0.09) ^{***}	0.08 (0.02) ^{§§§}	0.34 (0.08) [§]	0.92 (0.07) ^{##}
Serum OHB, N = 12	35.1 (2.4)	154.4 (26.3) ⁺⁺⁺	247.7 (43.3) ^{***,†}	31.5 (3.3) ^{§§§}	59.4 (19.9) ^{§§}	414.8 (58.5) [#]

4.3.3 Liver volume, glycogen and lipid

Compared with the baseline 'fed-state', liver volume decreased following 12 (-6%) and 24 hours (-11%) of fasting (Table 4.2, Figure 4.6). Refeeding with the study drink attenuated any further decline in liver volume. Fasting for 12 and 24 hours led to a 29% and a 57% decrease in liver glycogen reserves, respectively. By 2 hours following ingestion of ONS, liver glycogen reserves had increased by 47%. Twenty-four hours of fasting also led to a 34% decrease in liver lipid concentrations (Figure 4.6), the latter being unaffected by intake of the study drink.

Table 4.2: The effects of fasting and refeeding with the study drink (ONS) on liver volume and glycogen concentrations. *Liver volume* – Data are expressed in litres [mean (SE)]. *Liver glycogen* – Data are expressed in mmol [mean (SE)]. [†]*P*<0.05, ^{†††}*P*<0.001 indicate significant differences between values after 12 hour fast and those at the baseline ‘fed’ state. ^{***}*P*<0.001 indicates significant difference between values after 24 hour fast and those at baseline. ^{†††}*P*<0.001 indicate significant differences in values after 24 hour fast and those after 12 hour fast. ^{§§}*P*<0.01 indicates significant difference between values 2 hours after ONS and those after 24 hour fast. [§]*P*<0.05 indicates significant difference between values 6 hours after ONS and those after 24 hour fast.

	Baseline ‘fed’ state (4 hours after standard meal)	After 12 hour fast	After 24 hour fast	2 hours after study drink	6 hours after study drink
Liver volume, N = 12	1.8 (0.09)	1.7 (0.10) [†]	1.6 (0.09) ^{***, †††}	1.6 (0.09)	1.5 (0.08)
Liver glycogen, N = 12	590.1 (60.1)	421.3 (40.4) ^{†††}	255.9 (27.4) ^{***, †††}	377.2 (49.8) ^{§§}	370.0 (41.6) [§]

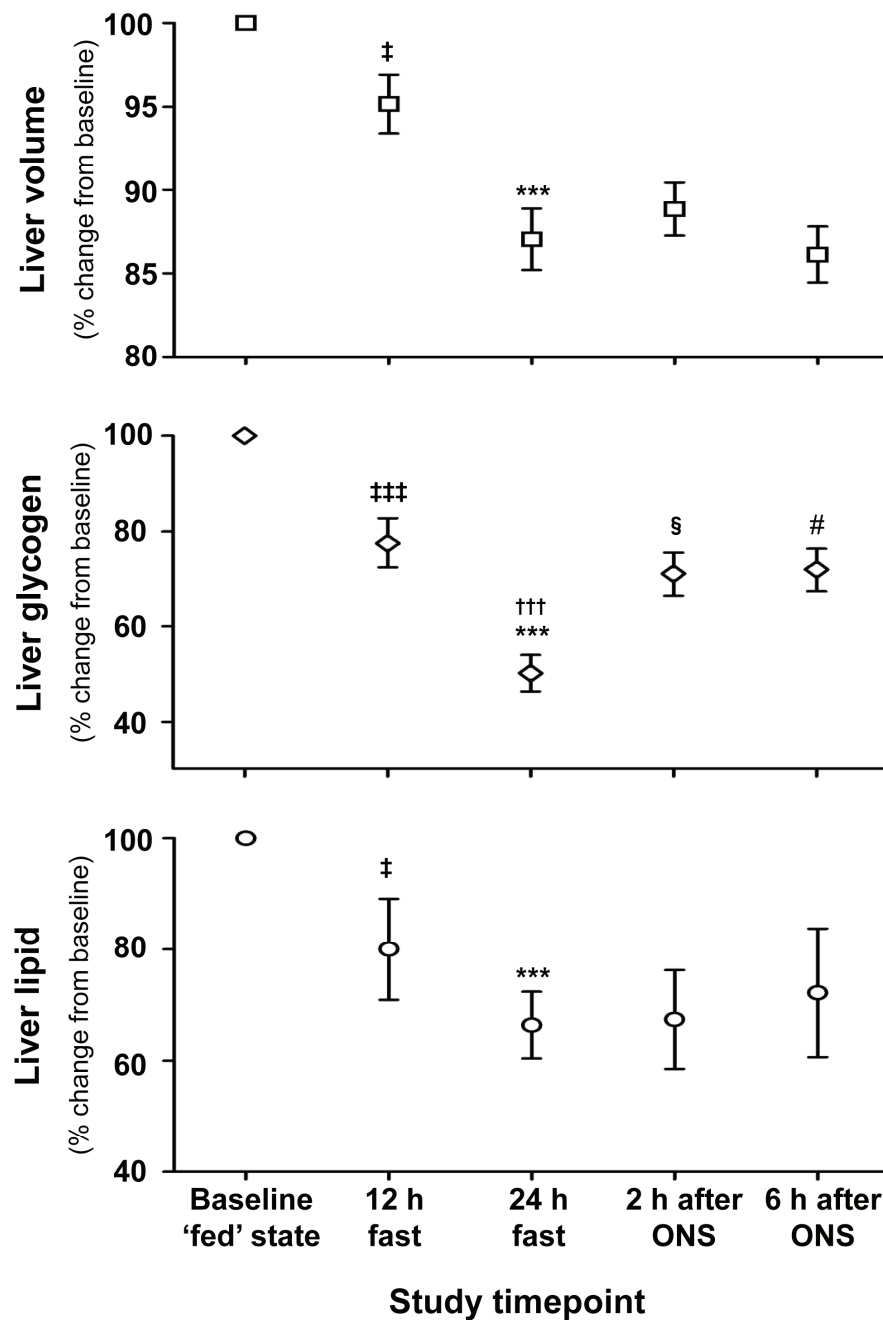

Figure 4.6: The effects of fasting and refeeding with the study drink (ONS) on liver volume, glycogen and lipid concentrations (N = 12). *Liver volume, glycogen and lipid concentrations* – Data are expressed as % change from baseline [mean (SE)]. † $P < 0.05$, ††† $P < 0.001$ indicate significant differences between values after 12 hour fast and those at the baseline 'fed' state. *** $P < 0.001$ indicates significant difference between values after 24 hour fast and those at baseline. ††† $P < 0.001$ indicate significant

differences in values after 24 hour fast and those after 12 hour fast. [§] $P < 0.05$ indicates significant differences between values 2 hours after ONS and those after 24 hour fast. [#] $P < 0.05$ indicates significant differences between values 6 hours after ONS and those after 24 hour fast.

4.3.4 Muscle glycogen and lipid

There were no differences in calf muscle glycogen or EMCL concentrations over the course of the study (data not shown). Compared to baseline, IMCL concentrations increased (23%) following 24 hours of fasting (Figure 4.7).

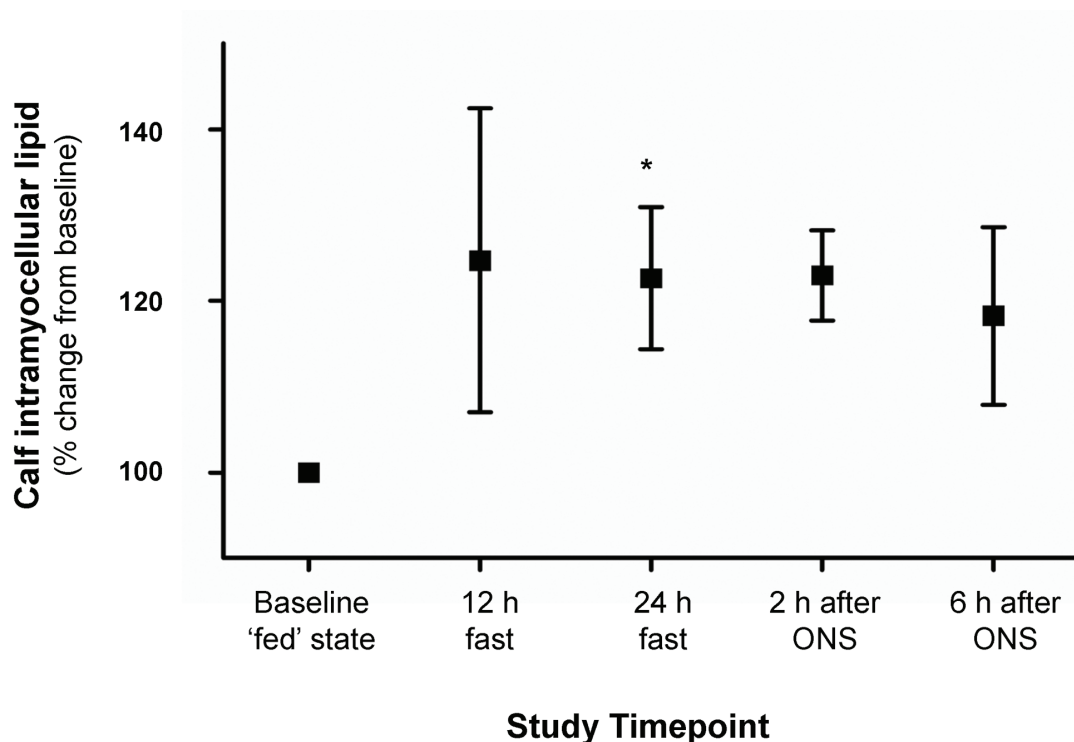

Figure 4.7: The effects of fasting and refeeding with the study drink (ONS) on calf intramyocellular lipid concentrations (N = 12). Data are expressed as % change from baseline [mean (SE)]. * $P < 0.05$ indicates significant differences in IMCL concentrations after 24 hour fast compared to concentrations at baseline.

4.3.5 Mononuclear cell mitochondrial membrane complex activity

Compared with the baseline 'fed' state, a 24 hour fast decreased MMC I and II activities (-75% and -43%, respectively, Table 4.3). Twenty-four hours of fasting also decreased MMC I, II and IV activities compared with those seen following a 12 hour fast (-72%, -49% and -41%, respectively). Mean activities of MMC I, II and IV increased 4 hours after ingestion of ONS but this did not reach statistical significance.

Table 4.3: The effects of fasting and refeeding with the study drink (ONS) on mononuclear cell mitochondrial membrane complex activity. Data are expressed as $\mu\text{mol}/\text{min}/\text{g}$ protein [mean (SE)]. * $P<0.05$, ** $P<0.01$ indicate significant difference in MMC activity after 24 hour fast from that at the baseline 'fed' state. $^{\dagger}P<0.05$, $^{\dagger\dagger}P<0.01$ indicate significant difference in MMC activity after 24 hour fast from that seen after 12 hour fast.

	Baseline 'fed' state (4 hours after standard meal)	After 12 hour fast	After 24 hour fast	4 hours after study drink
MMC I activity, N = 7	51.7 (16.3)	45.9 (14.1)	12.8 (5.0) ^{*,†}	29.6 (12.5)
MMC II activity, N = 12	29.8 (4.4)	33.2 (4.9)	17.0 (2.4) ^{**,††}	21.4 (3.3)
MMC IV activity, N = 11	30.4 (8.1)	37.6 (9.5)	22.2 (5.5) [†]	28.9 (8.0)

4.4 Discussion

This was the first investigation of simultaneous changes in liver and skeletal muscle substrate reserves, intermediary concentrations and MNC mitochondrial function in healthy humans who were fasted and then refed using a drink designed to improve metabolic function perioperatively i.e. metabolic preconditioning. A healthy volunteer model was selected and 'resembled' the perioperative scenario, when patients are fasted for prolonged periods, in order to avoid the possible confounding effects of anaesthesia and surgery.

This study demonstrated a 29% and 57% decrease in liver glycogen concentrations following 12 and 24 hours of fasting, in line with a previous MRS study (Rothman *et al.*, 1991). Fasting also led to a diminution in liver lipid reserves reflecting decreased lipogenesis. The progressive decline in liver volume following fasting was likely to have resulted from the utilisation of glycogen reserves, given that glycogen is a hydrophilic molecule that is stored in a hydrated form with three times its own weight in water (Frayn, 1999). Other reasons may include the utilisation of liver lipid reserves and a decrease in liver and portal blood flow following fasting leading to a decreased hepatic blood volume (Gaiani *et al.*, 1989). As would be expected, 24 hours of fasting did not deplete muscle glycogen reserves; the latter would require prolonged high intensity exercise given that the rate of muscle glycogen breakdown is intimately linked to the intensity of contraction (Bergstrom and Hultman, 1967). Finally, there was a 23% increase in IMCL concentrations following a 24 hour fast. This

finding has not previously been demonstrated after such a short period (24 hours) of fasting and was in accordance with findings from another group who demonstrated a 175% increase in IMCL concentrations following a 67 hour fast (Johnson et al., 2006). Interestingly, in that study (Johnson et al., 2006) the increase in IMCL concentration correlated negatively with insulin sensitivity ($r=-0.63, P<0.01$).

Thorell *et al.* (Thorell *et al.*, 1996a) previously studied patients undergoing elective open cholecystectomy and demonstrated a 65% higher liver glycogen concentrations in those allocated to an overnight preoperative glucose infusion (5 mg/kg/min) compared with traditional preoperative fasting. In the present study, refeeding with ONS led to a 47% increase in liver glycogen concentrations by 2 hours. Refeeding also increased plasma insulin concentrations which remained elevated for 4 hours after ingestion of the drink. The insulinogenic response at 4 hours differed between the standard mixed-meal and ONS and may be related to the differing carbohydrate and protein contents of the two meals {Floyd, 1966 #509; Nilsson, 1973 #593; Nilsson, 1973 #592; Shively, 1986 #508}. Refeeding also led to a decrease in NEFA and ketone body concentrations. Importantly, the latter effects persisted for only 4 hours following which substrate concentrations increased over and above those measured at the fasted state. The increases in NEFA and OHB may have occurred as a result of increasing lipolysis and ketogenesis (low insulin concentrations) associated with decreased NEFA and OHB utilisation (high carbohydrate and low fat oxidation in peripheral tissues following carbohydrate loading).

Previous studies have reported that postoperative function of MNC mitochondria, and thereby the immune responses, were impaired if preceded by fasting but these studies were confounded by the effects of anaesthesia and surgery (Delogu et al., 2001a; Delogu *et al.*, 2001b). This study has demonstrated that increasing the duration of fasting from 12 to 24 hours significantly decreased mononuclear cell MMC I (-72%), II (-49%) and IV (-41%) activities. Similar findings have been demonstrated in animal and human studies, albeit following longer periods (5 days) of low energy feeding (Madapallimattam et al., 2002; Briet et al., 2004). Generally, the decrease in MMC activity reflects a decrease in mitochondrial oxidative phosphorylation capacity, thereby decreasing ATP synthesis capacity and resulting in low energy status (Nelson et al., 2008). The findings of this study demonstrate that short-term fasting *per se* affects MNC mitochondrial activity adversely, independent of the effects of general anaesthesia and the postoperative cytokine response. Future studies should investigate whether these effects act to increase the susceptibility to postoperative infections.

Previous investigators have demonstrated a correlation between MMC activity in MNC and that in skeletal muscle (Briet and Jeejeebhoy, 2001). Although further definitive studies would be needed, the findings from the present study may raise the possibility that fasting might induce mitochondrial perturbations in muscle. The latter could lead to decreased insulin sensitivity through 'lipid-induced insulin resistance' (Roden *et al.*, 2001). Impaired muscle mitochondrial function coupled with increased delivery of fatty acids from plasma (elevated

fasting NEFA concentrations) may lead to the accumulation of IMCL metabolites such as fatty acyl CoAs and diacylglycerol (Morino *et al.*, 2006). Such findings were noted in young lean insulin-resistant offspring of parents with type 2 diabetes, where severe defects in insulin-stimulated muscle glucose metabolism were associated with an 80% increase in IMCL concentrations and a 30% reduction in rates of mitochondrial activity [ATP production] (Petersen *et al.*, 2004).

The present study could not demonstrate that refeeding with the carbohydrate-based drink reversed the decline in MMC activity seen following fasting but the time point chosen to measure mononuclear cell MMC activity following refeeding may not have been optimal. An increase in MMC activity may have occurred before or after this time point. Furthermore, this study did not seek to measure the relative changes in insulin sensitivity, given the difficulty in performing a hyperinsulinaemic-euglycaemic clamp alongside the MRS scanning and blood sampling protocols. It would have been inappropriate to use other means of determining insulin sensitivity [such as Homeostatic Model Assessment, HOMA (Matthews *et al.*, 1985)] as subjects were in a 'fed', not fasted, state for part of the protocol.

In summary, the present study has demonstrated that short-term fasting (up to 24 hours) decreased substrate reserves and affected MNC mitochondrial function adversely. Refeeding with a drink suitable for 'metabolic preconditioning' partially reversed the changes in liver glycogen.

Chapter 5

Cellular mechanisms underlying the protective effects of preoperative feeding: a randomised study investigating muscle and liver glycogen concentrations, mitochondrial function, gene and protein expression

The effects of preoperative fasting and conditioning with carbohydrate-based drinks on mitochondrial function and the expression of key metabolic genes and proteins involved in the pathways leading to the development of insulin resistance has never been studied in humans (Chapter 1).

5.1 Aims

The aims of this study were to:

- A) Investigate whether the ingestion of ONS was safe and the extent to which the additional ingredients (glutamine and antioxidants) were absorbed and resulted in altered plasma concentrations,
- B) Investigate the effects of ONS ingestion on liver and muscle glycogen reserves and mitochondrial function, and
- C) Study the effects of preoperative fasting and preoperative conditioning with carbohydrate-based drinks on the expression of PDK4, FOXO1 and Mt-1A.

5.2 Methods

5.2.1 Study design

This randomised, double-blind, placebo-controlled pilot study was set in a university hospital. Adult patients aged between 18-80 yrs with a body weight of 50-120 kg undergoing elective inpatient laparoscopic cholecystectomy for uncomplicated gallstone disease were invited to participate in the study

between April 2008 and July 2009. Exclusion criteria included: pregnancy, breastfeeding, epilepsy, diabetes, gastro-esophageal reflux disease, hiatus hernia, inherited metabolic disorders, choledocholithiasis, HIV, the presence of severe organ-specific disorders such as liver/kidney insufficiency, acute pancreatitis or psychiatric disorders, patients with known/suspected drug/alcohol abuse or those thought unlikely to cooperate with the study protocol. This was commercial study in part and was monitored by an independent monitor appointed by Fresenius Kabi, Germany.

5.2.2 Interventions

Participants reported to the laboratory at 7:30 pm on the day prior to surgery where height and weight were recorded and blood was sampled (Figure 5.2).

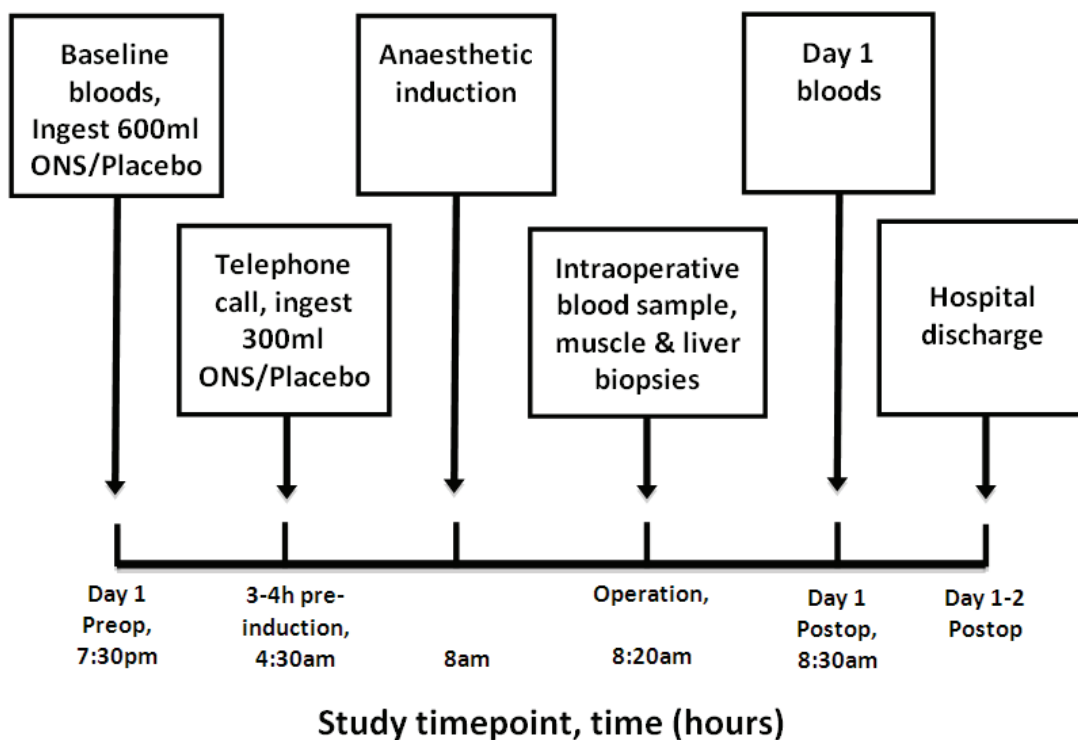

Figure 5.2: Schedule of study. Note that each serving of the powered ONS drink was reconstituted to a total volume of 300 ml.

At 8 pm patients ingested 2 servings (600 ml) of either the study drink (ONS, 50 g carbohydrate per 300 ml serving) or placebo (0 g carbohydrate per 300 ml serving) and were allowed home with instructions to fast from food and calorie-containing drinks. Each serving of ONS was delivered in powdered form and was reconstituted with bottled water to a volume of **300 ml**. The placebo drink contained only artificial colorings and flavorings. On the morning of surgery, approximately 3 to 4 hours prior to induction of anaesthesia, patients were contacted by telephone and instructed to ingest the final serving of the study drink (300 ml). This time point was chosen given that the mean (95% CI) T_{100}

gastric emptying time of ONS was 156 (138-174) min (Lobo et al., 2009). Patients were admitted to hospital at 7 am. After induction of general anaesthesia, blood was sampled prior to the commencement of surgery. Muscle biopsies were obtained immediately after making a 12 mm skin incision at the site of the infraumbilical port. Part of the rectus abdominis muscle was isolated between 2 suture ligatures and approximately 500 mg of muscle tissue were sampled using a scalpel. Muscle tissue was immediately blotted dry, dissected free of adipose and connective tissue and snap frozen in liquid nitrogen. After placement of the other laparoscopic access ports, liver biopsies (total approximately 250 mg) were obtained using a Tru-Cut® biopsy needle (Cardinal Health, Dublin, OH, USA) and immediately snap frozen in liquid nitrogen until analysis. Frozen muscle and liver samples were subsequently divided in liquid nitrogen into smaller parts for the various assays. On the first postoperative day, blood was sampled again and the patients were allowed home when deemed appropriate by the medical team.

5.2.3 Randomisation

The randomisation code was given to a person not involved in the study who prepared the study drinks. The drinks were delivered in sealed sequentially numbered identical containers according to the allocation sequence. The investigators allocated patients an ascending serial number in the order of their enrolment, which corresponded to the randomisation number and allocated the patient to one of the two treatment groups.

5.2.4 Blood samples

Blood samples included FBC, U&Es, liver enzymes, CRP, glucose, insulin, FFA and concentrations of vitamin C, vitamin E, β -carotene, selenium, zinc and free amino acids.

5.2.5 Mitochondrial function

Frozen muscle tissue (15-20 mg) was homogenised for 2 min on ice in homogenisation buffer, 50 μ l/mg muscle, (pH 7.2) consisting of KCl (100mM), KH_2PO_4 (50mM), Tris (50mM), MgCl_2 (5mM), EDTA (1mM) and ATP (1.8mM) using Duall® glass tissue grinders (Anachem Ltd., Luton, UK). Frozen liver tissue (5-15 mg) was homogenised in the aforementioned homogenisation buffer at a concentration of 150 μ l/mg liver. Muscle and liver MMC activities were measured spectrophotometrically and the kinetic assays performed in duplicate (section 4.2.7.2). Muscle mitochondrial β -hydroxyacyl CoA dehydrogenase (β -HAD) activity was measured as described previously (Chi *et al.*, 1983). Protein concentrations were determined in the mitochondrial and enzyme suspensions by the Bradford dye-binding (Bio-Rad) assay (section 3.6).

5.2.6 ATP, phosphocreatine (PCr) and glycogen measurements

After freeze-drying approximately 30 mg of liver and muscle tissue, visible blood and connective tissue were removed and the samples powdered. ATP, PCr and glycogen concentrations were determined spectrophotometrically using a modification of the method of Harris *et al* {Harris, 1974 #551}.

5.2.7 Muscle glutamine concentrations

Having arranged a Human Tissue Transfer Agreement (HTTA), muscle samples were shipped on dry ice and glutamine concentrations measured by Dr. van Eijk (NUTRIM School for Nutrition, Toxicology and Metabolism of the Maastricht University Medical Centre, the Netherlands). In brief, muscle samples were homogenized using 100 mg of glass pearls (1 mm diameter) and a micro beat beater (BioSpec Products, Bartlesville, OK, USA) for 15 s in 5% (w/v) ice-cold sulfosalicylic acid. The homogenate was centrifuged for 10 min at 50 000 *g* and glutamine concentrations were determined as previously described (van Eijk *et al.*, 1993).

5.2.8 Quantitative RT-PCR

RNA was extracted from 20-30 mg frozen muscle and 10-20 mg frozen liver tissue using TRI Reagent® (Ambion, Huntingdon, UK). First strand cDNA was

synthesized from 1 µg of total RNA using Murine Moloney Leukaemia Virus (MMLV) reverse transcriptase (Promega, Southampton, UK) and random primers (Promega). All reactions were performed in the ABI Prism 7000 Sequence Detection System (Applied Biosystems, Foster City, CA, USA). Each well contained 2 µl cDNA, 12.5 µl Taqman® Gene Expression master mix (Applied Biosystems), 1.25 µl probe and 9.25 µl RNase-free water to make a volume of 25 µl. Each sample was measured in duplicate. The housekeeping gene used was hydroxymethylbilane synthase [HMBS] (Crossland *et al.*, 2008). The thermal cycling conditions used were 2 min at 50°C, 10 min at 95°C, followed by 40 cycles at 95°C for 15 s and 60°C for 1 min. PDK4, FOXO1 and Mt-1A mRNA expression was determined. Relative quantification of the genes of interest was measured using the $2^{-\Delta\Delta C_t}$ method. The Ct values for the gene of interest were normalized with the Ct values of HMBS. The placebo group was used as calibrator with a value of 1.

5.2.9 Western blotting

Western blotting was performed by Dr Despina Constantin (Metabolic Physiology Group, School of Biomedical Sciences, University of Nottingham). An aliquot of each wet frozen muscle sample was homogenised in Tris buffer (Tris 50 mM/EDTA 1 mM pH 7.5) supplemented with protease and phosphatase inhibitors (Sigma, Dorset, UK). After homogenisation, each muscle extract was

centrifuged for 15 min at 10,000 *g*. The supernatant was collected and stored at -80°C. Protein concentrations were measured by the Bradford dye-binding (Bio-Rad) assay (section 3.6). Protein samples were run on a 4-12 % Bis-Tris acrylamide gel (Invitrogen, Paisley, UK) for 2 hours at constant 200 V and transferred on a polyvinylidene difluoride membrane (PVDF) overnight at constant 100 mA, in ice-cold buffers (4°C). The protein transfer was checked with Ponceau S red staining, before blocking the membrane in BSA and Tris buffer saline (TBS) for 1 hour at room temperature. Membranes were then probed with the primary antibody overnight at 4°C. The antibodies used in this study (phosphorylated FOXO [serine256] and total FOXO1) and PDK4 were obtained from Cell Signaling Technology (Danvers, MA, USA), and AbCam Inc (Cambridge, USA), respectively. The next day, the membranes were washed in TBS-Tween 20, incubated with an IRDye 800 labelled secondary anti-rabbit antibody and further quantified by using an Odyssey® Infrared Imaging System (LI-COR, Biosciences, NE, USA).

5.2.10 Study outcomes

This pilot study aimed at determining whether the ingestion of ONS preparation was associated with the occurrence of drink-related side effects such as pulmonary aspiration, nausea, vomiting, flatulence or diarrhoea. Additional

measures included: differences between the two groups of patients in plasma glutamine, antioxidant, glucose, insulin and FFA concentrations; liver and muscle glycogen concentrations and mitochondrial function, muscle glutamine concentrations, and finally, liver and muscle PDK4, FOXO1 and Mt-1A mRNA expression.

5.3 Results

One hundred and sixteen patients were screened for inclusion into the study of whom 40 were randomised into the two groups (Figure 5.3).

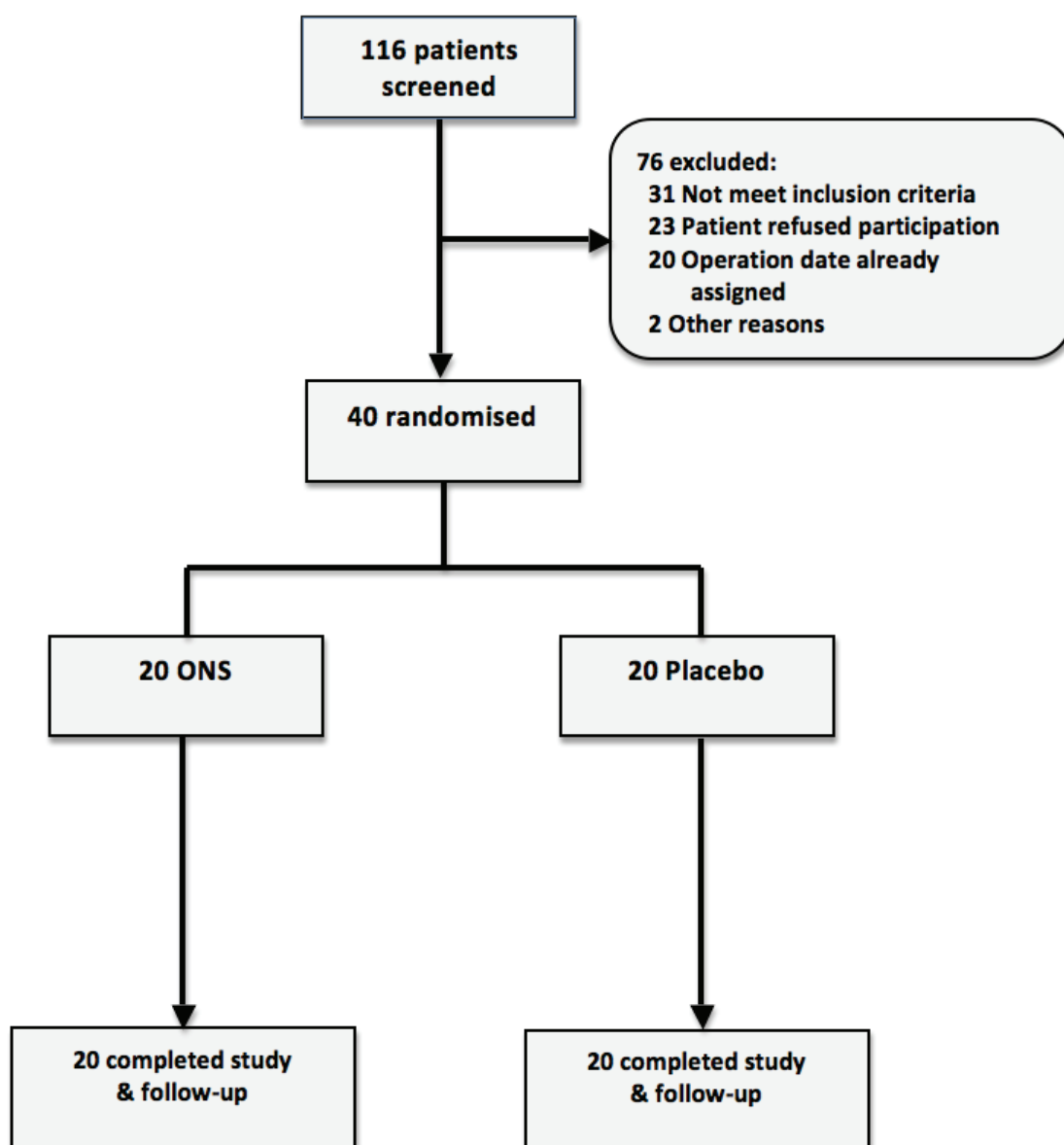

Figure 5.3: Trial flow chart.

The mean (SE) age and body mass index of the 20 patients (16 female) in the placebo group were 48.8 (2.9) years and 28.8 (1.2) kg/m² respectively. Corresponding values for the 20 patients (15 female) in the ONS group were 51.9 (3.0) years and 29.2 (1.3) kg/m². These differences were not statistically significant. Patients ingested the final serving of the drinks a mean (SE) of 234 (5.5) min prior to induction of anaesthesia with no differences between the groups. All patients ingested the study drinks at the required time and there were no drink-related complications such as nausea, vomiting, aspiration, hypersensitivity and diarrhea. Muscle and liver biopsies were obtained after a median (IQR) of 251 (235-279) and 260 (241-285) min after ingestion of the second serving of the study drinks with no differences observed between the 2 groups.

5.3.1 Metabolic assays

There were no differences in FBC, U&E, liver enzymes and CRP (data not shown). Similarly, there were no differences between intraoperative blood glucose and insulin concentrations between the 2 groups (Table 5.1).

Table 5.1: Mean (SE) blood glucose, insulin, free fatty acid, glutamine and antioxidant concentrations in the ONS and placebo groups. Independent samples t test for all comparisons. †N = 19 for placebo group FFA.

	Placebo group (N = 20)	ONS group (N = 20)	P value
Intraoperative plasma glucose concentration, mmol/L	4.86 (0.1)	4.74 (0.1)	0.465
Intraoperative serum insulin concentration, mIU/L	5.1 (0.94)	5.3 (1.2)	0.665
Intraoperative plasma FFA concentration, mmol/L	0.81 (0.06)	0.56 (0.04)	<0.01
Intraoperative plasma glutamine concentration, μmol/L	556 (12)	609 (23)	<0.05
Intraoperative plasma vitamin C concentration, μmol/L	63 (5)	125 (7)	<0.0001
Intraoperative plasma vitamin A concentration, μmol/L	1.3 (0.1)	1.7 (0.2)	0.091
Intraoperative plasma selenium concentration, μmol/L	71 (3)	83 (3)	<0.01
Day 1 postoperative plasma glucose concentration, mmol/L	5.79 (0.33)	5.77 (0.29)	0.96
Day 1 postoperative plasma glutamine concentration, μmol/L	581 (17)	665 (27)	<0.05
Day 1 postoperative plasma vitamin C concentration, μmol/L	46 (4)	66 (3)	<0.001
Day 1 postoperative plasma vitamin A concentration, μmol/L	1.1 (0.1)	1.5 (0.1)	<0.05
Day 1 postoperative plasma selenium concentration, μmol/L	67 (3)	75 (3)	<0.05

Intraoperative FFA concentrations were significantly higher in the placebo group (Table 5.1) and there was a significant negative correlation with PDK4 mRNA (Figure 5.4).

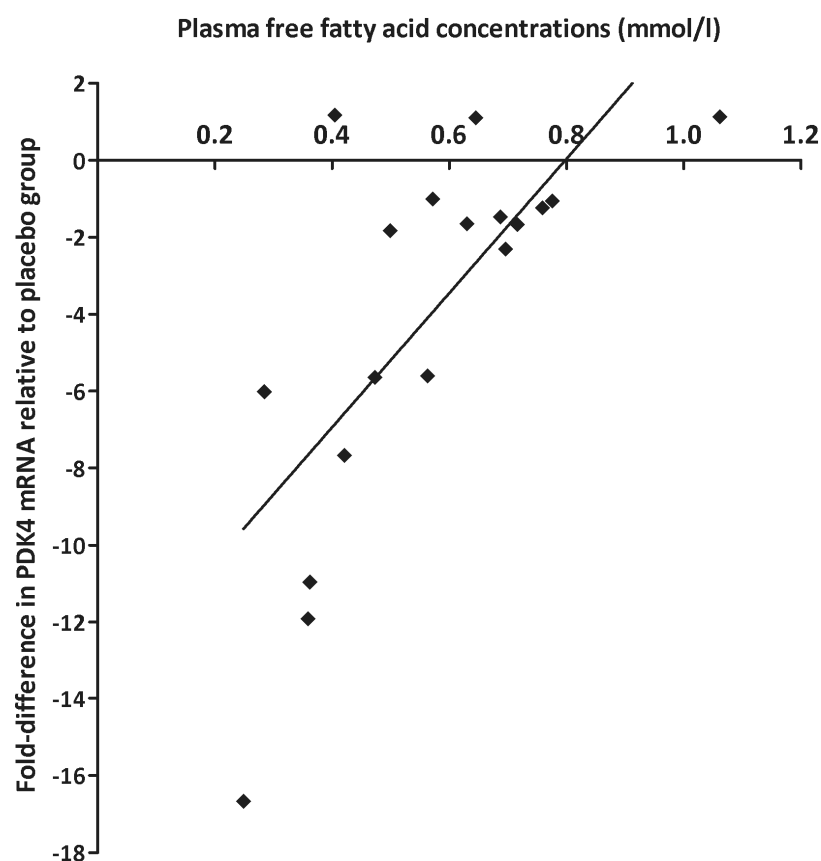

Figure 5.4: Correlation between plasma FFA concentrations and the fold-difference in PDK4 mRNA in the ONS group (relative to the placebo group).

Pearson's correlation was used. N = 18.

Ingestion of ONS led to elevated intraoperative concentrations of glutamine, vitamin C, vitamin A and selenium (Table 5.1) with elevated concentrations persisting into the first postoperative day.

4.3.2 Glycogen and muscle glutamine concentrations

Preoperative ingestion of ONS led to a highly significant 44% increase in liver but not muscle glycogen concentrations (Table 5.2). Although mean muscle glutamine concentrations tended to be higher in the ONS group, this did not reach statistical significance.

Table 5.2: Intraoperative muscle and liver glycogen and muscle glutamine concentrations in the ONS and placebo groups. †N = 16 in placebo group for glutamine concentration due to limited amount of biopsy tissue. Independent samples t-test for all comparisons.

	Placebo group (N = 20) [†]	ONS group (N = 20)	P value
Mean (SE) muscle glycogen concentration, (mmol/kg dry weight)	263 (15.0)	261 (24.4)	0.963
Mean (SE) liver glycogen concentration, (mmol/kg dry weight)	694 (47.7)	999 (49.3)	<0.001
Log_n mean (SE) muscle glutamine concentration, (mmol/kg wet weight)	2.44 (0.05)	2.61 (0.07)	0.078

5.3.3 Mitochondrial function

There were no differences in muscle or liver MMC II, II + III, IV or citrate synthase activities between the 2 study groups (Table 5.3). Similarly, there were no differences in muscle β -HAD activity, ATP and PCr concentrations (Table 5.3).

Table 5.3: Intraoperative muscle and liver MMC activity, muscle β -HAD, ATP and phosphocreatine concentrations in the ONS and placebo groups. N = 20 in each group for all muscle analyses except β -HAD where N = 20 in placebo group and 18 in ONS group. N = 19 in each group for all the liver analyses. Independent samples t-test.

		Placebo group	ONS group	P value
Muscle	Mean (SE) MMC II activity, ($\mu\text{mol}/\text{min}/\text{g}$ protein)	282.6 (26.1)	302.9 (20.9)	0.548
	Mean (SE) MMC II + III activity, ($\mu\text{mol}/\text{min}/\text{g}$ protein)	498.1 (95.3)	615.4 (90.1)	0.377
	Mean (SE) MMC IV activity, ($\mu\text{mol}/\text{min}/\text{g}$ protein)	805.5 (130.0)	1164.9 (240.6)	0.445
	Mean (SE) Citrate Synthase activity, ($\mu\text{mol}/\text{min}/\text{g}$ protein)	838.7 (101.3)	809.4 (107.5)	0.844
	Mean (SE) β -HAD activity, ($\mu\text{mol}/\text{min}/\text{g}$ protein)	22.3 (4.0)	18.3 (3.0)	0.748

	Mean (SE) ATP concentrations, (mmol/kg dry muscle)	17.2 (0.7)	16.2 (0.63)	0.304
	Mean (SE) Phosphocreatine concentrations, (mmol/kg dry muscle)	91.2 (5.1)	91.6 (4.4)	0.952
Liver	Mean (SE) MMC II activity, (mmol/min/g protein)	2.52 (0.14)	2.48 (0.12)	0.826
	Mean (SE) MMC II + III activity, (mmol/min/g protein)	1.09 (0.13)	1.02 (0.10)	0.665
	Mean (SE) MMC IV activity, (mmol/min/g protein)	0.47 (0.07)	0.41 (0.06)	0.502
	Mean (SE) Citrate Synthase activity, (mmol/min/g protein)	0.15 (0.02)	0.16 (0.02)	0.900

5.3.4 Gene and protein expression

Compared with the placebo group, there were significantly lower expressions of muscle PDK4 mRNA (4-fold) and protein (44%) in the ONS group (Table 5.4 and Figure 5.5). There were no differences in muscle FOXO1 mRNA, phosphorylated-FOXO1 (FOXO1^{Ser256}) or total FOXO1 protein expression between the study

groups (Table 5.4 and Figure 5.5). There was also a significantly lower (1.5-fold) muscle antioxidant gene Mt-1A expression in the ONS group (Table 5.4). There were no significant differences in liver PDK4, FOXO1 and Mt-1A mRNA expression (Table 5.4).

Table 5.4: Fold-differences in intraoperative muscle and liver PDK4, FOXO1 and Mt-1A mRNA expression in the ONS group relative to the placebo group. Due to limited amount of biopsy tissue N = 18, 16 and 15 in each group for muscle PDK4, FOXO1 and Mt-1A, respectively. N = 17 in each group for liver analyses. Significance determined using Mann-Whitney U-test.

	Gene	Mean (SE) fold-differences in mRNA expression in ONS group relative to the placebo group	P value
Muscle	PDK4	-4.07 (1.2)	<0.001
	FOXO1	0.26 (0.6)	0.189
	Mt-1A	-1.49 (2.1)	<0.001
Liver	PDK4	-0.57 (0.5)	0.118
	FOXO1	0.03 (0.4)	0.348
	Mt-1A	0.38 (0.4)	0.394

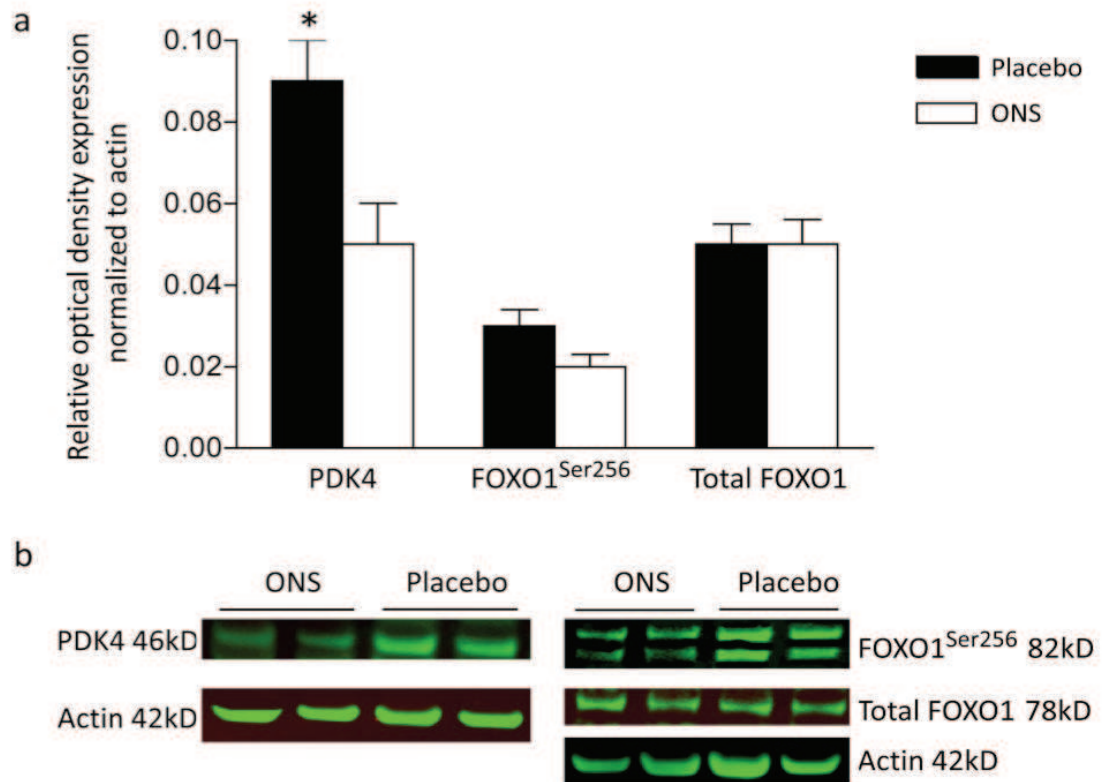

Figure 5.5a: Muscle PDK4 and Forkhead box O (FOXO) 1 (phosphorylated-FOXO1^{Ser256} and total) protein expression in the ONS and the placebo groups.

*Significantly different from placebo ($P < 0.05$).

b: Typical Western blots for PDK4, phosphorylated (FOXO1^{Ser256}) and total FOXO1 in the ONS and placebo groups.

5.4 Discussion

The results from this study have demonstrated for the first time in patients undergoing surgery that: 1) preoperative feeding with a carbohydrate drink that also contained glutamine and antioxidants (ONS) was well tolerated and led to increased plasma glutamine and antioxidant concentrations, changes that persisted into the first postoperative day, 2) preoperative ingestion of ONS resulted in lower expression of skeletal muscle PDK4 mRNA and protein, and 3) ingestion of ONS was associated with lower metallothionein-1A expression indicating decreased cellular oxidative stress.

The constituents of ONS were absorbed and led to increased plasma glutamine and antioxidant concentrations, changes which persisted up to the first postoperative day. There was also a tendency towards higher muscle glutamine concentrations in the ONS group intraoperatively. Whilst glutamine supplementation in critically ill surgical patients has been associated with reduced infectious complications, morbidity and improved metabolic control (Houdijk et al., 1998; Bakalar et al., 2006; Dechelotte et al., 2006), a recent study has suggested that in patients undergoing elective surgery for gastrointestinal cancer, glutamine supplementation did not reduce surgical morbidity (Gianotti *et al.*, 2009). There is, however, evidence that preoperative conditioning with immune enhancing supplements e.g. glutamine and antioxidants may improve the immunometabolic host response (Braga *et al.*, 1999; Tepaske *et al.*, 2001; Baines and Shenkin, 2002; Gianotti *et al.*, 2002; Henriksen *et al.*, 2003). Ingestion

of ONS also led to a 44% increase in liver glycogen concentrations, confirming the findings from the magnetic resonance spectroscopy study (Chapter 3). However, there was no difference in muscle glycogen concentrations, which was not surprising given that this period of fasting without exercise would not have depleted muscle glycogen reserves (Bergstrom and Hultman, 1967).

In the present study a surgical model that induced minimal surgical stress (laparoscopic surgery) was selected to evaluate the effects of preoperative fasting versus feeding *per se*, without the confounding effects of major surgery (Thorell et al., 1993). Although otherwise healthy patients undergoing laparoscopic cholecystectomy may not routinely need preoperative nutritional support, preoperative carbohydrate loading may reduce postoperative insulin resistance in this group of patients as well (Faria *et al.*, 2009). Muscle and liver biopsies were obtained close to the commencement of the operation. At this time the placebo group had been fasted for approximately 12-14 hours and both study groups had experienced minimal surgical stress (induction of anaesthesia and skin incisions associated with minimal access surgery). A previous healthy volunteer study demonstrated a 4-fold upregulation in skeletal muscle PDK4 mRNA expression following 48 hours of starvation, associated with a 42% reduction in whole body insulin sensitivity (Tsintzas et al., 2006). These changes were independent of the phosphorylation status of the transcription factor FOXO1 protein. Accordingly, the present study has demonstrated that even following a short period of fasting (15 hours) and minimal operative stress, there was a 4-fold lower expression of muscle PDK4 mRNA and 44% lower expression

of protein in the ONS group, compared with the placebo group, with no differences seen in FOXO1 mRNA or protein expression. These novel findings suggest a mechanism by which preoperative feeding with carbohydrate-based drinks attenuates the development of insulin resistance which otherwise would result from preoperative fasting (Essen *et al.*, 1995; Thorell *et al.*, 1996b; Thorell *et al.*, 1999b; Faria *et al.*, 2009). The protective effects of preoperative feeding, demonstrated in previous studies (Essen *et al.*, 1995; Thorell *et al.*, 1996b; Thorell *et al.*, 1999b; Faria *et al.*, 2009) may, therefore, be secondary to lower muscle PDK4 expression, thereby enabling PDC activity and carbohydrate oxidation. Although ONS contained glutamine and antioxidants in addition to carbohydrate, it is likely that these effects were related, in part, to the carbohydrate constituent of the drink given that previous studies have demonstrated reversal of starvation-induced changes in PDK4 expression and PDC activity following refeeding with a carbohydrate-rich diet (Wu *et al.*, 1999; Tsintzas *et al.*, 2006). Previous studies have also examined the roles of insulin, FFA and transcription factors such as peroxisome proliferator-activated receptors (PPAR) α and δ with a view to understanding the mechanisms involved in regulating the PDK4 gene (and therefore PDC activity) (Lee *et al.*, 2004; Kim *et al.*, 2006; Tsintzas *et al.*, 2006; Tsintzas *et al.*, 2007; Connaughton *et al.*, 2009). Insulin strongly suppressed PDK4 expression in skeletal muscle (Lee *et al.*, 2004; Connaughton *et al.*, 2009) but this effect was attenuated by elevated FFA concentrations (Kim *et al.*, 2006; Tsintzas *et al.*, 2007). On the basis of animal experiments, it has been proposed that elevated FFA mediated the starvation-

induced upregulation of PDK4 expression via a PPAR-dependent process (Wu et al., 1999), however, these findings were contrary to a previous healthy volunteer study (Tsintzas et al., 2006) from our laboratory. In the current study, there were no differences in intraoperative insulin concentrations between the two groups. The restraining effect of insulin on adipose tissue lipolysis persisted for 4 hours after ingestion of ONS as evidenced by the lower FFA concentrations in the ONS group. Elevated plasma FFA concentrations result in increased fatty acid flux through skeletal muscle, the latter a possibly resulting in elevated IMCL concentrations (Phillips *et al.*, 1996). Interestingly, PDK4 mRNA expression correlated significantly with FFA concentrations (Figure 4.4) providing further evidence that elevated FFA concentrations may indeed regulate PDK4 expression, albeit in a manner distinct from PPAR pathways. There were no differences in liver PDK4 and FOXO1 mRNA expression between the two groups, providing further evidence that the liver does not play a major role in mediating the development of fasting-induced insulin resistance.

Another novel finding in this study was the 1.5-fold lower expression of Mt-1A mRNA in muscle, indicative of a reduction in cellular oxidative stress, in the ONS 'fed' group. Increased plasma Mt-1 concentrations have been noted after elective surgery (Akintola *et al.*, 1997) and a previous study has demonstrated that metallothionein increased mitochondrial inner membrane permeability (Simpkins *et al.*, 1998). However, future studies would be needed to study the respective contributions of the ingredients of ONS to this finding and the clinical implications of lower Mt-1A mRNA expression on mitochondrial function. In this

study, no differences were detected in liver and muscle mitochondrial function between the two study groups.

A major limitation of this study was that it is not possible to attribute the aforementioned beneficial effects solely to one of the constituents of the drink (carbohydrate, glutamine and antioxidants). Further studies would need to investigate the contributions of the different constituents of the drink to any potential beneficial effects observed. Furthermore, as muscle and liver were sampled at the commencement of surgery, changes in gene and protein expression demonstrated in the present study are likely to have resulted from preoperative fasting as opposed to surgical stress *per se*.

In conclusion, the present study has demonstrated that preoperative ingestion of a carbohydrate-based drink that contained glutamine and antioxidants was associated with lower muscle PDK4 mRNA and protein expression. The differences in muscle PDK4 are a mechanism by which preoperative feeding with carbohydrate-based drinks attenuates changes in insulin sensitivity that result from preoperative fasting.

Chapter 6

A randomised crossover study of the metabolic and hormonal responses following ingestion of two 'preoperative' conditioning drinks

A previous study demonstrated, using magnetic resonance imaging, that the gastric emptying of the two drinks (preOp® and ONS) differed significantly in healthy volunteers (Lobo et al., 2009). Whilst the mean (95% CI) T_{100} of 400 ml of preOp® was 94 (79-110) min, that of the same volume of ONS was 156 (138-173) min. This difference was thought (Lobo et al., 2009) to be due to the presence of particulate matter in the ONS suspension and differing nutrient loads of the two drinks.

6.1 Aims

The aims of the present study were to study the postprandial metabolic and hormonal responses following ingestion of preOp® and ONS. Understanding these responses may help optimise the timing of administration of these drinks preoperatively, given that the optimal time of ingestion prior to surgery may not necessarily be the time at which the drinks empty from the stomach.

6.2 Methods

6.2.1 Interventions

Volunteers abstained from alcohol and caffeine for 24 hours, and from strenuous exercise for 3 days prior to the study. The study commenced at 7:30 am following an overnight fast. Height and weight were recorded and a retrograde

venous cannula sited in the dorsum of the hand to allow sampling of arterialised blood. Baseline bloods (*vide infra*) were sampled, following which the subjects were randomised to receive one of the two study drinks. The constituents and physical properties of the two study drinks are listed in section 3.7. ONS was reconstituted from powdered form (70 g) with water to a volume of 400 ml on the morning of the study. Participants ingested the drink within 1 min and time 0 was defined as the end of the drink. Blood samples were obtained at 20 min intervals for 360 min. Subjects attended for the second arm of the study after an interval of 5-7 days.

6.2.2 Blood samples

Blood was sampled for FBC, U&E, liver enzymes, CRP at baseline and for glucose, insulin, glucagon, NEFA and glutamine at baseline and every 20 min after ingestion of the drinks for 360 min. Blood samples for NEFA were collected into chilled tubes containing preservatives to prevent lipolysis elevating NEFA concentrations (200 μ l ethylene glycol tetraacetic acid and glutathione (7.5 μ l/ml blood) and 3 mg/ml tetrahydrolipstatin (5 μ l/ml blood). Blood samples for β -hydroxybutyrate (OHB) were collected into a microcentrifuge tube containing 10% perchloric acid (2 μ l/ μ l blood), mixed to allow precipitation and frozen at -20°C until analysis. Paired samples were selected from 6 volunteers at random for measurement of glutamine concentrations.

6.2.3 Study outcomes and statistics

The key outcome measure in this pilot study was differences in postprandial glucose concentrations. Other outcomes included differences in postprandial concentrations of insulin, glucagon, NEFA and OHB. As this was a pilot study it was not possible to perform a sample-size calculation. However, based on the results of a previous study (Lobo et al., 2009) N=12 volunteers were considered a sufficient number to demonstrate clinically relevant differences between the 2 drinks. Comparisons between the study time points were made using the two-way repeated measures ANOVA with the paired t post-hoc test. Two-tailed *P*-values, unadjusted for multiple testing, are reported and differences were considered significant at $P < 0.050$.

6.3 Results

The mean (SE) age, weight, height and BMI of the 12 volunteers were 21.4 (0.9) yrs, 74.4 (1.96) kg, 1.79 (0.02) m and 23.2 (0.48) kg/m² respectively. All subjects completed the study with no reported side effects. There were no differences in FBC, U&E, liver enzymes and CRP between the two study arms (data not shown).

6.3.1 Glucose, insulin and glucagon concentrations

Following ingestion of preOp[®], glucose concentrations peaked within 40 min (Figure 6.1A) before returning to baseline concentrations at 80 min. In contrast, ONS ingestion led to a smaller peak (within 40 min) in glucose concentrations, the latter remaining higher than those following preOp[®] at 100 min. Ingestion of preOp[®] led to significantly higher insulin concentrations (Figure 6.1B) than those seen following ONS, with peak concentrations occurring after 40 and 20 min, respectively. By 160 min, insulin concentrations had decreased in both groups to baseline values seen following an overnight fast. Compared to baseline, glucagon concentrations decreased (Figure 6.1C) following ingestion of preOp[®] with the lowest concentrations seen at 120 min. In contrast, this decrease in glucagon concentrations was not seen following ingestion of ONS, where concentrations remained higher than those in the preOp[®] arm.

A:

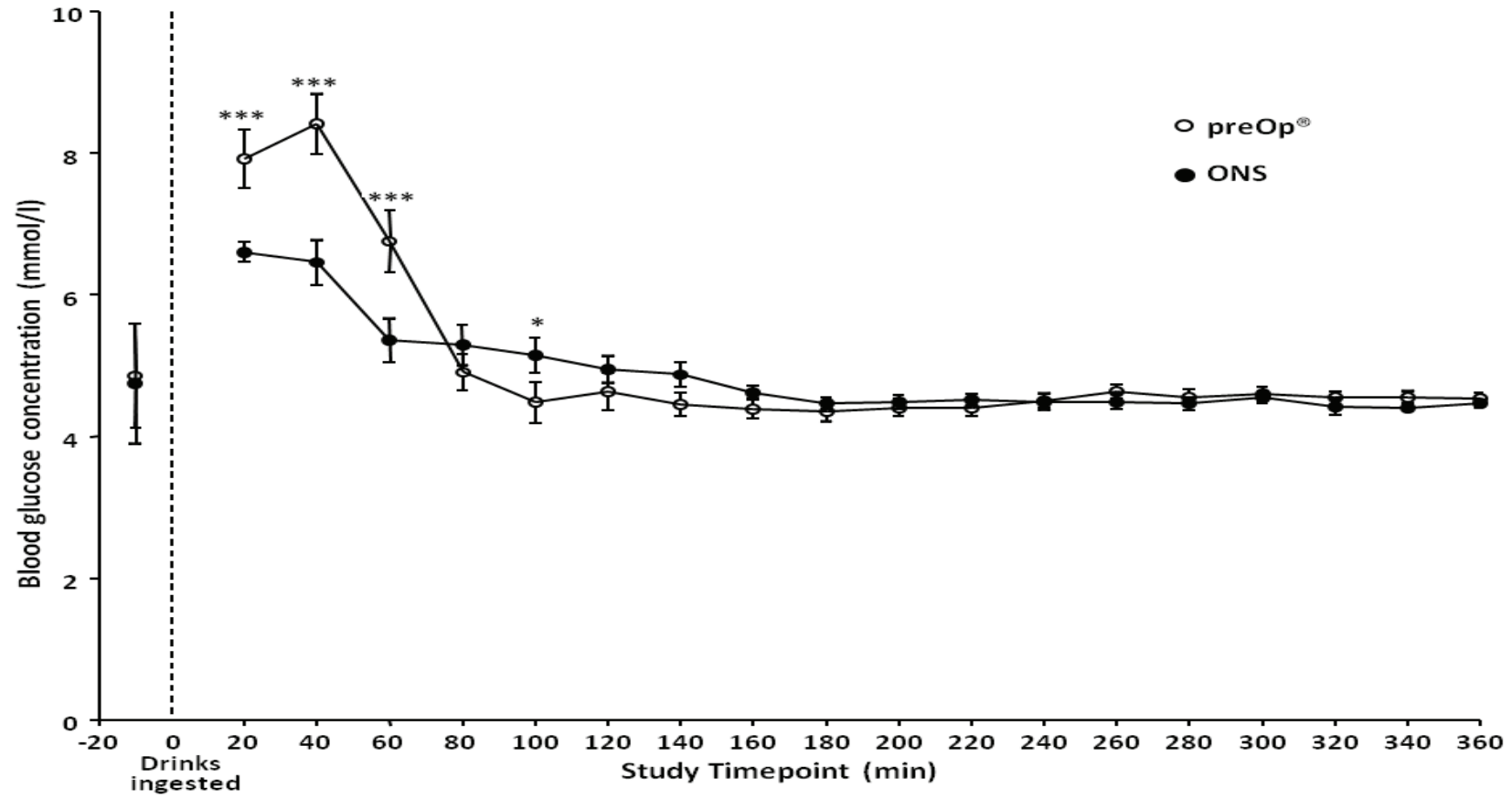

B:

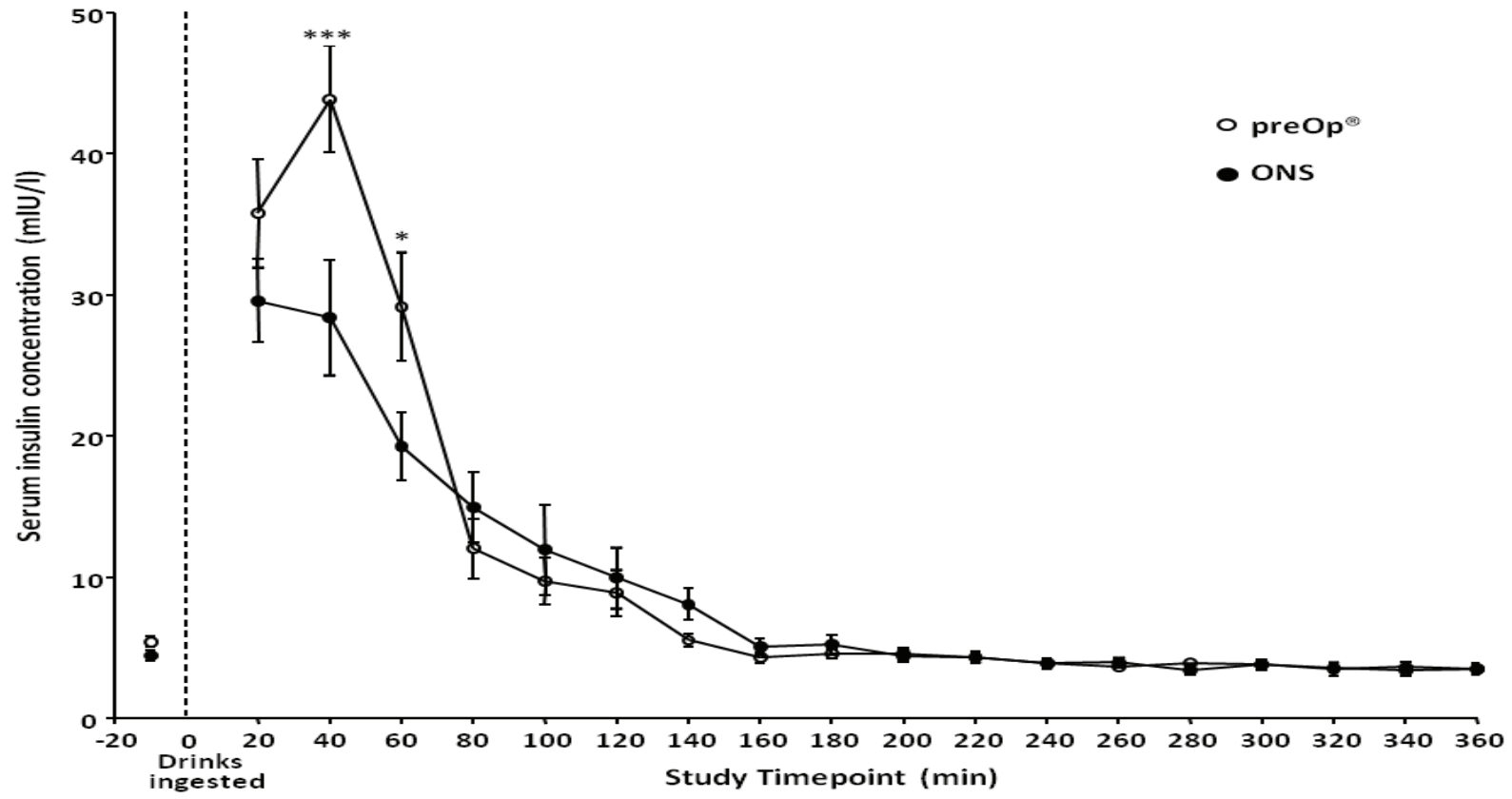

C:

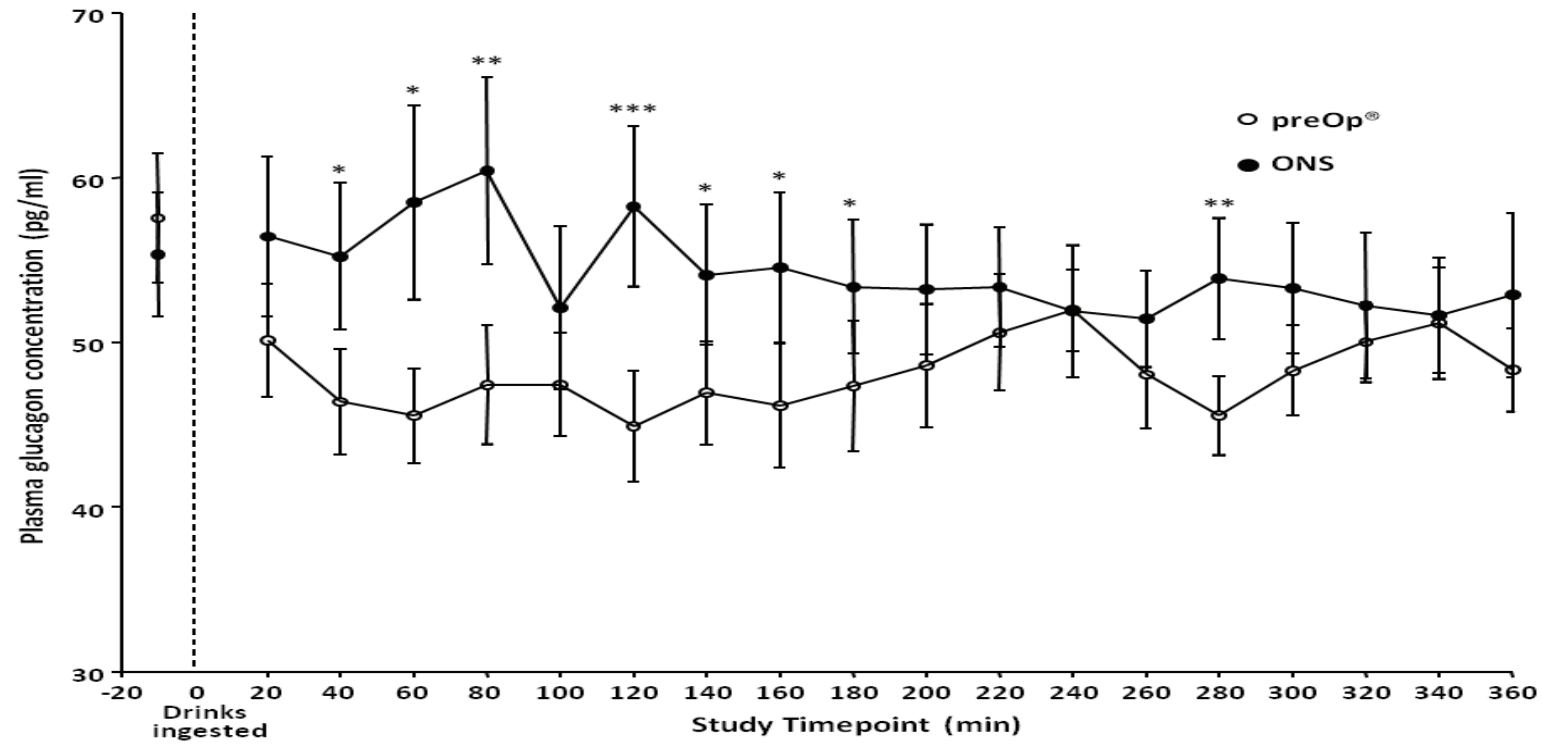
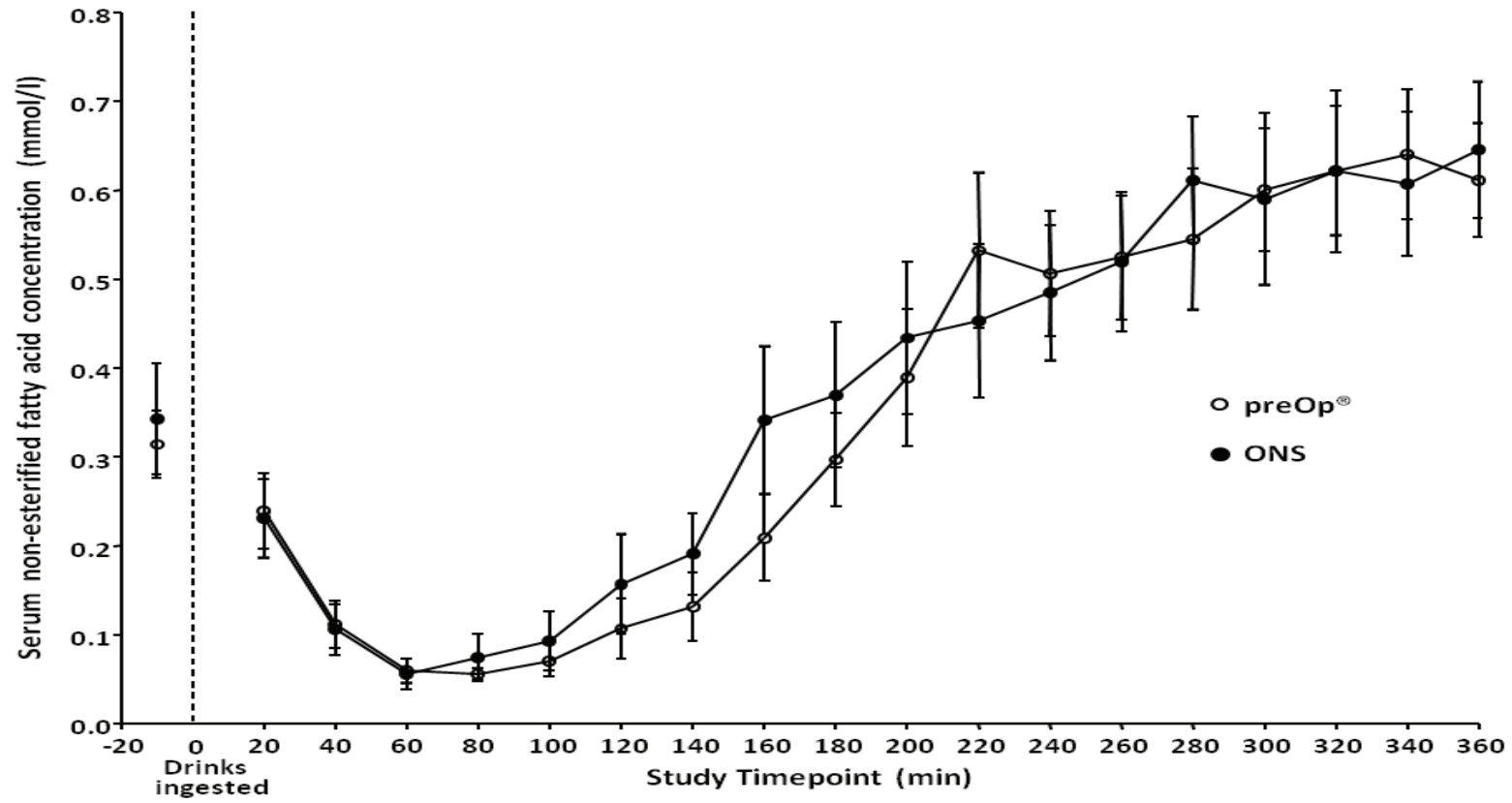

Figure 6.1: Blood glucose (A), serum insulin (B) and plasma glucagon (C) concentrations following ingestion of Nutricia preOp® (○) and ONS (●). N = 12. Statistical comparison of preOp® vs ONS: * $P < 0.05$, ** $P < 0.01$, *** $P < 0.001$.

6.3.2 NEFA and OHB concentrations

Ingestion of both study drinks led to a decrease in serum NEFA and OHB from concentrations measured following the overnight fast (Figure 6.2). There was a postprandial rebound increase in NEFA and OHB concentrations such that at 360 min, concentrations were 2- and 3-4-fold higher, respectively, than those seen following an overnight fast.

A:



B:

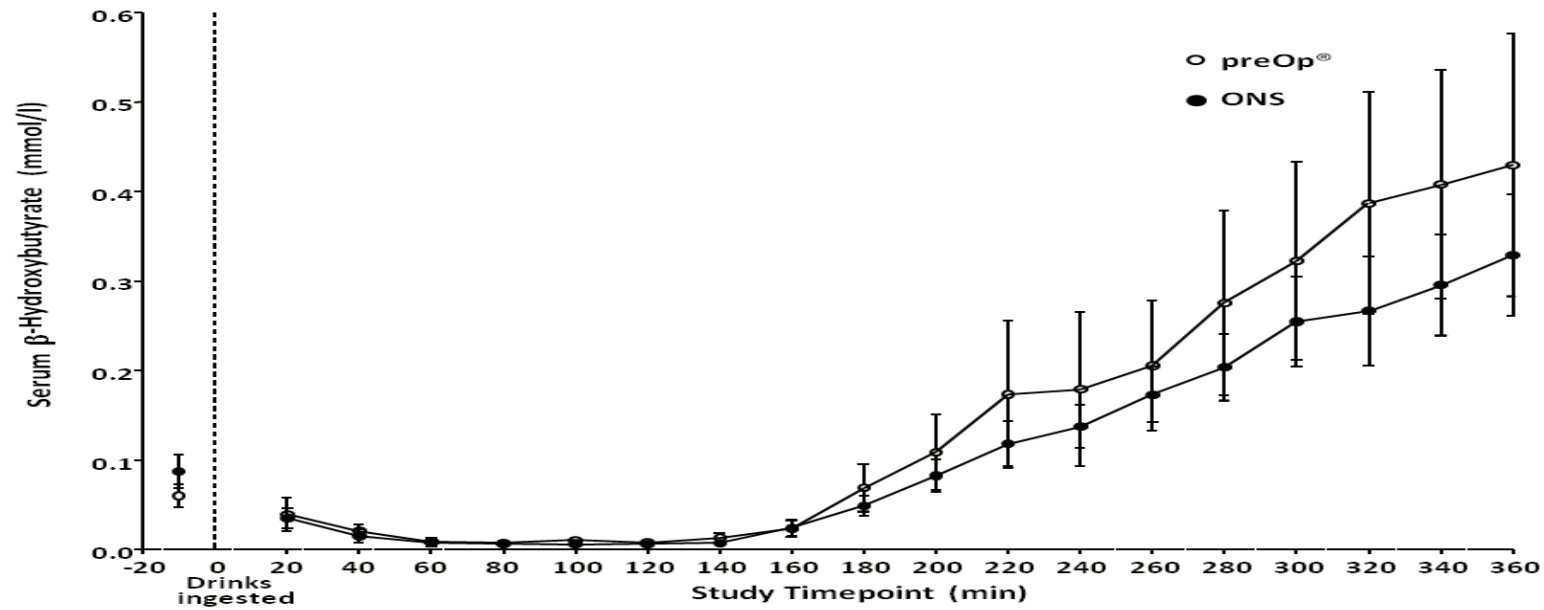

Figure 6.2: Serum non-esterified fatty acid (A, N=12) and serum β -hydroxybutyrate (B, N=11) concentrations following ingestion of Nutricia preOp® (○) and ONS (●).

6.3.3 Glutamine concentrations

As expected, ingestion of preOp® was not associated with a change in plasma glutamine concentrations (Figure 6.3). In contrast, ingestion of ONS was associated with significantly increased plasma glutamine concentrations that remained elevated for 120 min.

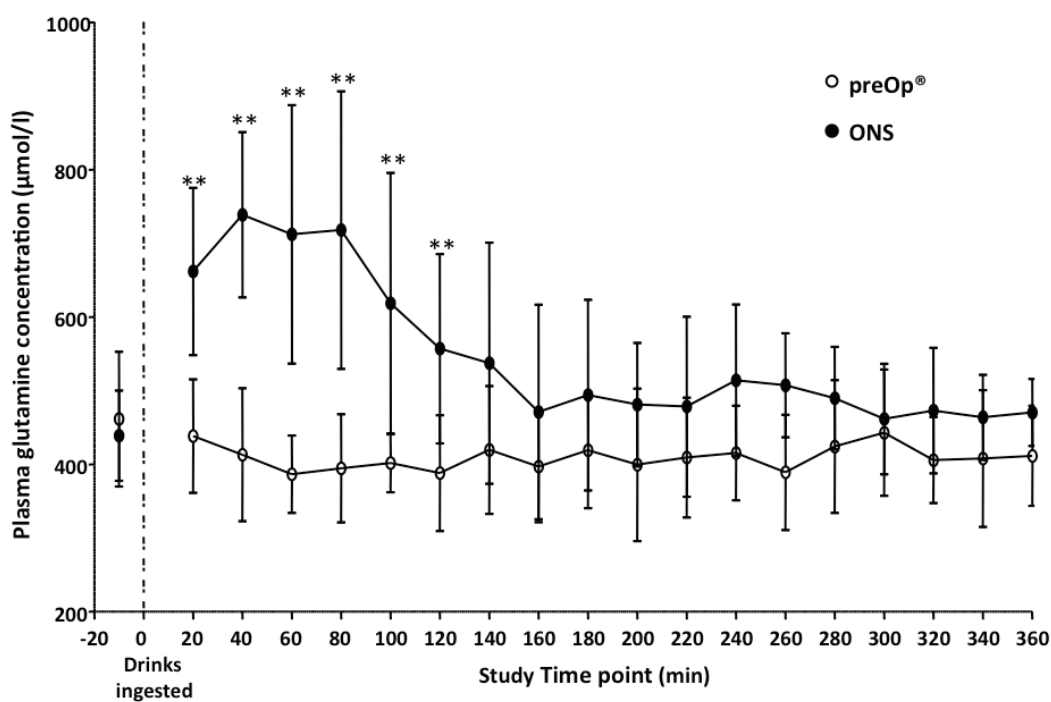

Figure 6.3: Plasma glutamine concentrations following ingestion of Nutricia preOp® (○) and ONS (●). N=6. Statistical comparison of preOp® vs ONS: ** $P < 0.01$.

6.4 Discussion

This study, in a healthy volunteer model selected to avoid possible confounding effects of anaesthesia and surgery, has demonstrated significant differences in the metabolic and hormonal responses following ingestion of two carbohydrate-based 'preoperative' drinks.

The peaks in glucose and insulin concentrations were 'blunted' after ingestion of ONS when compared with preOp®. Furthermore, ONS ingestion was associated with a slower decline in glucose and insulin from their postprandial peaks. Thus, ingestion of preOp® was associated with rapid changes, albeit higher concentrations, in glucose and insulin, while ONS led to more physiologically 'stable' responses with lower postprandial concentrations of glucose and insulin. The latter responses may be clinically advantageous in patients with type 2 diabetes and impaired glucose tolerance, especially as preoperative conditioning with carbohydrate-based drinks was shown to be well tolerated in this group (Breuer *et al.*, 2006; Gustafsson *et al.*, 2008).

The differing magnitudes of postprandial glucose and insulin responses may have occurred for a number of reasons. Firstly, the GE characteristics of the two drinks differed significantly (mean T_{100} for 400 ml of preOp® was 94 min and for ONS 156 min (Lobo *et al.*, 2009)) and the rate of GE is one of the determinants of postprandial glycaemic responses (Horowitz *et al.*, 1993). The more rapid GE of CCD could have led to greater postprandial increases in glucose concentrations thereby stimulating greater insulin release. In contrast, absorption of ONS may

have been delayed by slower GE thereby 'blunting' glucose and insulin responses. Secondly, the delay in GE following ONS ingestion may have resulted from increased glucagon-like peptide-1 (GLP-1) release from intestinal L cells. GLP-1 is an incretin known to delay GE (Greenfield et al., 2009) and a previous cell culture study has demonstrated glutamine to be a potent stimulant of GLP-1 release from GLUTag cells (murine GLP-1-secreting cell line) (Reimann et al., 2004). Finally, human studies have demonstrated that glutamine supplementation increases postprandial and post-exercise insulin-mediated glucose disposal without elevating plasma insulin (Borel *et al.*, 1998; Bowtell *et al.*, 1999; Iwashita *et al.*, 2005; Iwashita *et al.*, 2006). Increased glucose disposal following ONS ingestion could, therefore, have resulted in lower plasma glucose concentrations. However, the latter hypothesis requires further study.

In the present study the glutamine constituent of ONS was absorbed and led to increased plasma concentrations. Glutamine was shown to stimulate glucagon release (Greenfield et al., 2009), and this may have contributed to higher postprandial glucagon concentrations in the ONS arm. Although glucagon stimulates hepatic gluconeogenesis, a corresponding increase in plasma glucose concentrations was not noted following ONS.

The present study was limited in that changes in postprandial insulin sensitivity and glucose disposal were not measured. However, it was necessary to determine the metabolic response following ingestion of these study drinks to allow the appropriate timing of hyperinsulinaemic-euglycaemic clamps.

Furthermore, the study design did not permit analysis of the effects of differing carbohydrates mixtures within the drinks on postprandial glucose and insulin responses. However, previous studies have examined the effects of maltodextrins and fructose on liver lipogenesis, insulin sensitivity, hepatic insulin resistance and GE (Daly *et al.*, 1997; Soop *et al.*, 2004; Basciano *et al.*, 2005). It is also of note that the fructose constituent of preOp® may have been converted to glucose thereby further increasing postprandial plasma glucose concentrations over and above those seen in the ONS arm.

Chapter 7

**A randomised crossover study on the effects of glutamine
and lipid on the gastric emptying time of a preoperative
carbohydrate drink**

The mechanisms underlying the differing gastric emptying characteristics of the two drinks (ONS and preOp®) and the resultant metabolic effects were unclear, but may have been due to the stimulatory effect of amino acids on gastric secretion (Oberhelman *et al.*, 1952; Feldman *et al.*, 1978) or due to the increased viscosity and density caused by the addition of other nutrients to the carbohydrate constituent of the drinks (Marciani *et al.*, 2000). Furthermore, glutamine ingestion is thought to release glucagon-like peptide 1 (GLP-1), which is an incretin that delays gastric emptying (Reimann *et al.*, 2004; Karamanlis *et al.*, 2007; Greenfield *et al.*, 2009). Finally, the addition of lipid to liquid carbohydrate meals results in delayed gastric emptying (Houghton *et al.*, 1990) and blunted postprandial glucose and insulin responses (Welch *et al.*, 1987).

7.1 Aims

The aims of this study were, therefore, to investigate whether the addition of glutamine or lipid to a carbohydrate-based 'preoperative' conditioning drink, whilst maintaining isocaloricity, altered the gastric emptying characteristics and resultant postprandial glucose and insulin responses. Understanding these differences would allow the optimisation of the formulation and timing of administration of such drinks.

7.2 Methods

7.2.1 Interventions

Participants reported to the laboratory at 7:30 am following an overnight fast having abstained from alcohol and caffeine for 24 hours, and from strenuous exercise for 3 days prior to the study. Height and weight were recorded and a retrograde cannula sited in the dorsum of the hand to allow sampling of arterialised venous blood. Baseline bloods (*vide infra*) were sampled, following which radioactive markers (0.25 MBq ^{99m}Tc), were attached to the skin anteriorly and posteriorly at the lower right costal margin. Subjects were randomised to receive one of the three study drinks (Table 7.1, *vide infra*) which were ingested within 1 min, time 0 being defined as the end of the drink. Blood was sampled immediately followed by serial anterior and posterior scintigraphic images each of 30 sec duration (*vide infra*), at 20 min intervals for 240 min. Imaging was terminated prior to this if the isotope was not detectable in the stomach. Subjects attended for the subsequent two arms of the study after intervals of 5-7 days.

7.2.2 Randomisation

All study personnel were blinded to treatment assignment. It was not possible to fully blind the participants to treatment allocations as the drinks had different

textures and tastes. However, the participants were not informed of the order/which drink they had consumed.

7.2.3 Study drinks

Each of the three isocaloric-isovolumetric study drinks (carbohydrate only [CCD]; carbohydrate & glutamine [CCD/G], and carbohydrate & lipid [CCD/L], Table 7.1) was prepared at room temperature on the morning of the study using the appropriate volume of preOp[®], to which was added 2.5% weight for weight of an emulsifier (Tween 60V Pharma, Croda, Fogars de la Selva, Spain). An emulsifier was added to maintain the drinks in suspension and the lipid spatial distribution of the CCD/L drink (Marciani *et al.*, 2006).

Table 7.1: Constituents and physical properties of the three isocaloric-isovolumetric study drinks. The carbohydrate component was derived from preOp® (Nutricia Clinical Care, Trowbridge, UK), the volume of which was adjusted to ensure an equal energy load between the drinks.

	Carbohydrate only [CCD]	Carbohydrate & glutamine [CCD/G]	Carbohydrate & lipid [CCD/L]
Volume, ml	410	410	410
Approximate calories, kCal	207	207	207
Carbohydrate, g	50.4	36	36
Glutamine, g	0	15	0
Lipid, g	0	0	7
Tween 60 emulsifier, ml	10	10	10
Osmolality, mOsm/kg	297	460	207

To ensure that the three drinks were isocaloric and isovolumetric to CCD, the quantity of carbohydrate in the CCD/G and CCD/L formulations was reduced, and the overall caloric content maintained by addition of either 15 g glutamine (Adamin-G®, SHS International Ltd., Liverpool, UK) or 7 g lipid (Corn oil, Sainsbury's, London, UK). The drinks (CCD/G and CCD/L) were subsequently

brought to the required total volume (410 ml) using water. The drinks were mixed using a blender (Cookworks, Vancouver, BC, Canada) and transferred to identical opaque bottles to which was added 5MBq Tc-99m-DTPA was added as a non-absorbable tracer. The constituents and physical properties of the study drinks are given in Table 7.1. The 'stability' of the drinks, and ^{99m}Tc label contained therein, were studied *in vitro* by placing the drinks into 3 adjacent compartments of a VanKel 7000 dissolution instrument (VanKel Industries Inc, Edison, NJ, USA) maintained at 37°C by a heated water pump (VanKel VK750, Edison, NJ, USA). Static imaging (*vide infra*) of the chambers containing the drinks was performed with the gamma camera at 20 min intervals for 100 min (Figure 7.1A).

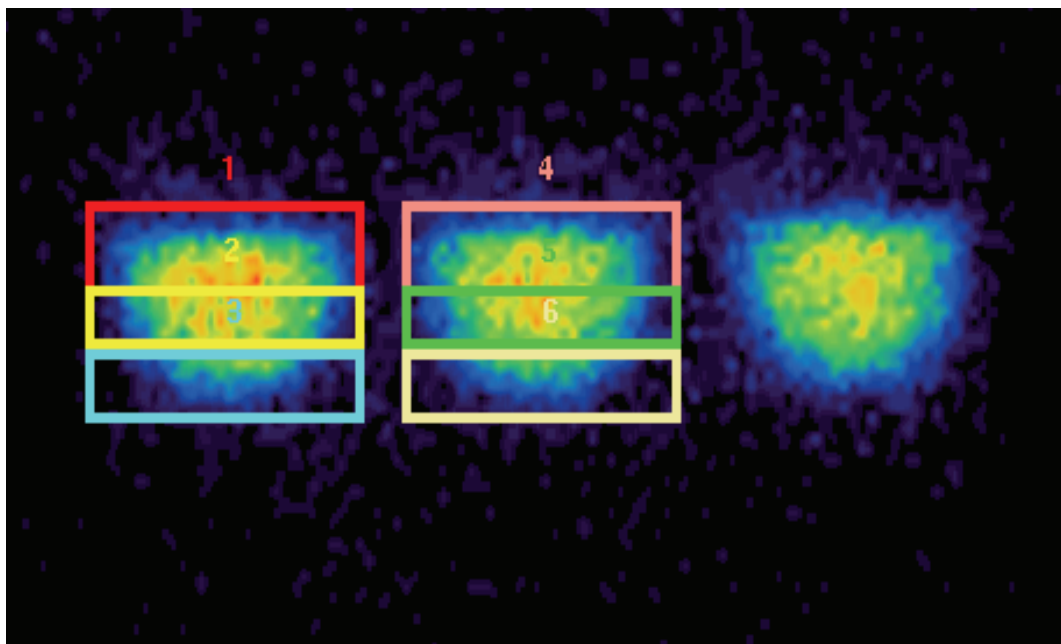

Figure 7.1A: *In vitro* dispersion and stability studies of the three study drinks (carbohydrate only drink [CCD], carbohydrate & glutamine drink [CCD/G], and carbohydrate & lipid drink [CCD/L]). The right chamber contains CCD; middle chamber CCD/G; and left chamber CCD/L. Regions of interest were drawn around the top, middle and bottom of each chamber to enable calculation of the count rates thereby indicating the distribution of the ^{99m}Tc label over time in these chambers.

Analysis of regions of interest (ROI) drawn over the top, middle and bottom of the dissolution chambers demonstrated that the drinks remained 'stable' over time with homogenous dispersion of the ^{99m}Tc label throughout (Figure 7.1B).

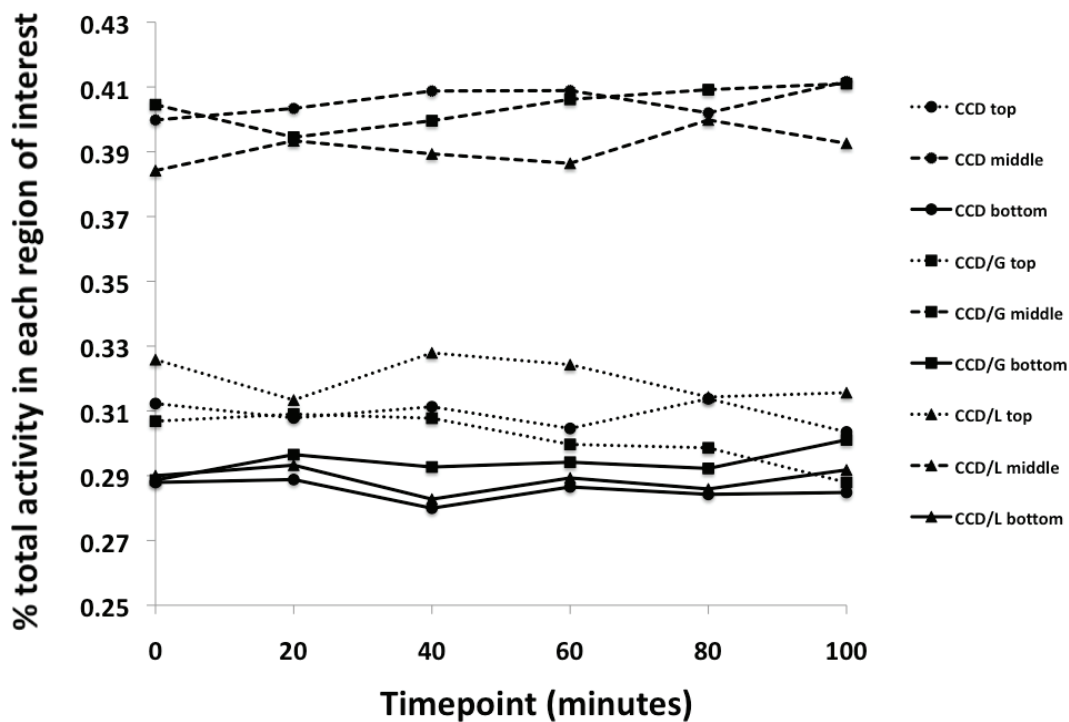

Figure 7.1B: Dispersion of the ^{99m}Tc label and stability of the drinks over a 100 min time period. No differences were found in the % change in count rates at the top, middle and bottom of the dissolution chambers with the passage of time indicating an even distribution of the ^{99m}Tc label within the study drinks.

To mimic the acidic environment of the stomach, the stability studies were repeated following the addition of 30 ml (Brady *et al.*, 2003) of simulated gastric fluid [SGF] (Test solutions) to the three drinks, the drinks again remaining stable following addition of SGF (Figure 7.1C).

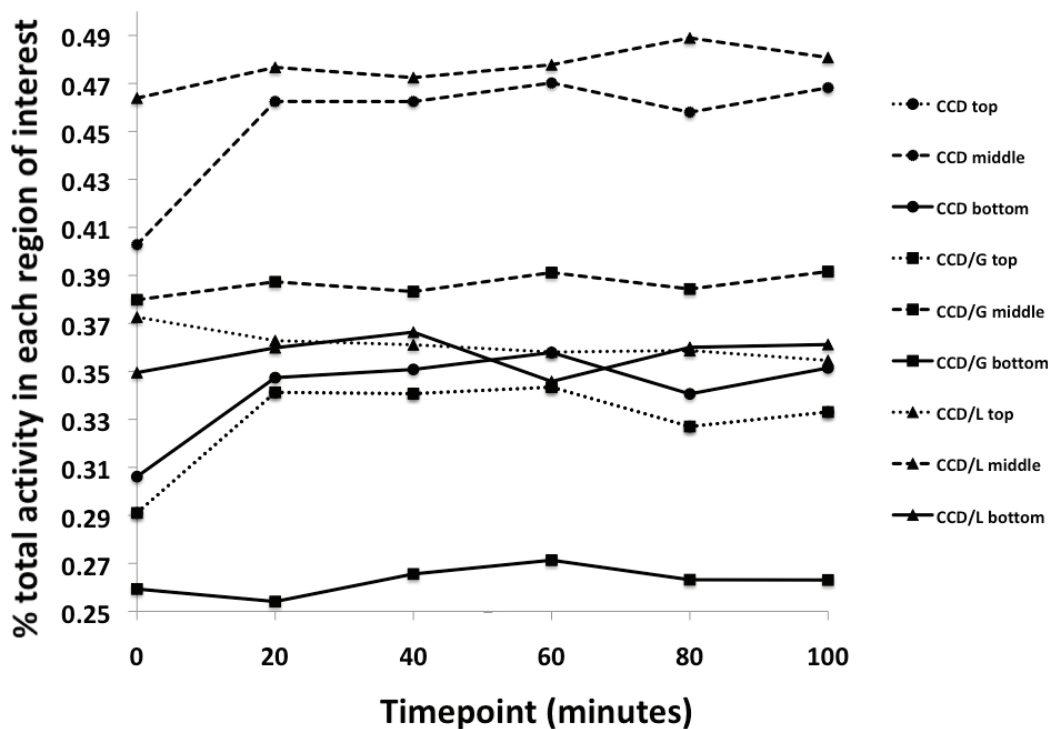

Figure 7.1C: Dispersion of the ^{99m}Tc label and stability of the drinks over a 100 min time period following addition of simulated gastric fluid to the study drinks. No differences were found in the % change in count rates at the top, middle and bottom of the dissolution chambers with the passage of time, indicating an even distribution of the ^{99m}Tc label within the study drinks.

7.2.4 Blood samples and metabolic assays

Arterialised venous blood was sampled for glucose, insulin, and GLP-1 concentrations.

7.2.5 Scintigraphic acquisitions and analyses

Scintigraphic data were acquired (by Ms. Elaine Blackshaw, Clinical Trials Manager, Department of Physics, Queen's Medical Centre, Nottingham) using a Mediso Nucline™ X-ring-R gamma camera (Mediso Medical Imaging Systems, Budapest, Hungary) fitted with a low energy collimator and peaked at 140 keV for ^{99m}Tc . The 256 x 256 pixel matrix images were transferred to a Hermes dedicated nuclear medicine computer (Nuclear Diagnostics, Gravesend, UK) for analysis. ROI were created around the computer-generated image of the stomach for both anterior and posterior images and counts were recorded. The count rates were corrected for background radiation, radionuclide decay and the geometric mean of the anterior and posterior measurements calculated. The time-activity curve was expressed as a percentage of the total meal in the stomach against time, from which the times for 50% and 90% emptying (T_{50} and T_{90}) were derived from simple interpolation of the data points on the gastric emptying curve.

7.2.6 Study outcomes and statistical analyses

The main outcome of this pilot study was the T_{90} gastric emptying time following ingestion of the study drinks. Secondary outcomes included T_{50} gastric emptying time, blood glucose, insulin and GLP-1 concentrations. As this was a pilot study it was not possible to perform a sample size calculation. However, based on the

results of a previous study (Lobo et al., 2009), we estimated that ten volunteers would be sufficient to detect clinically relevant differences between the three drinks. The three-way repeated measures ANOVA was performed with the paired t post-hoc test. Two-tailed P-values, unadjusted for multiple testing, are reported and differences were considered significant at $P < 0.050$.

7.3 Results

The mean (SE) age, weight, height and BMI of the participants were 29 (2) yrs, 69.4 (1.3) kg, 1.8 (0.01) m and 22.6 (0.3) kg/m², respectively. All ten subjects approached passed the inclusion criteria (Section 3.2) and agreed to participate in the study. All subjects completed the study with no reported side effects.

7.3.1 Gastric emptying times

There were no significant differences in the T₅₀ gastric emptying times between the three study drinks (Figure 7.2). In contrast, the T₉₀ times were shortest for the CCD/L, being significantly different from the CCD (Figure 7.2).

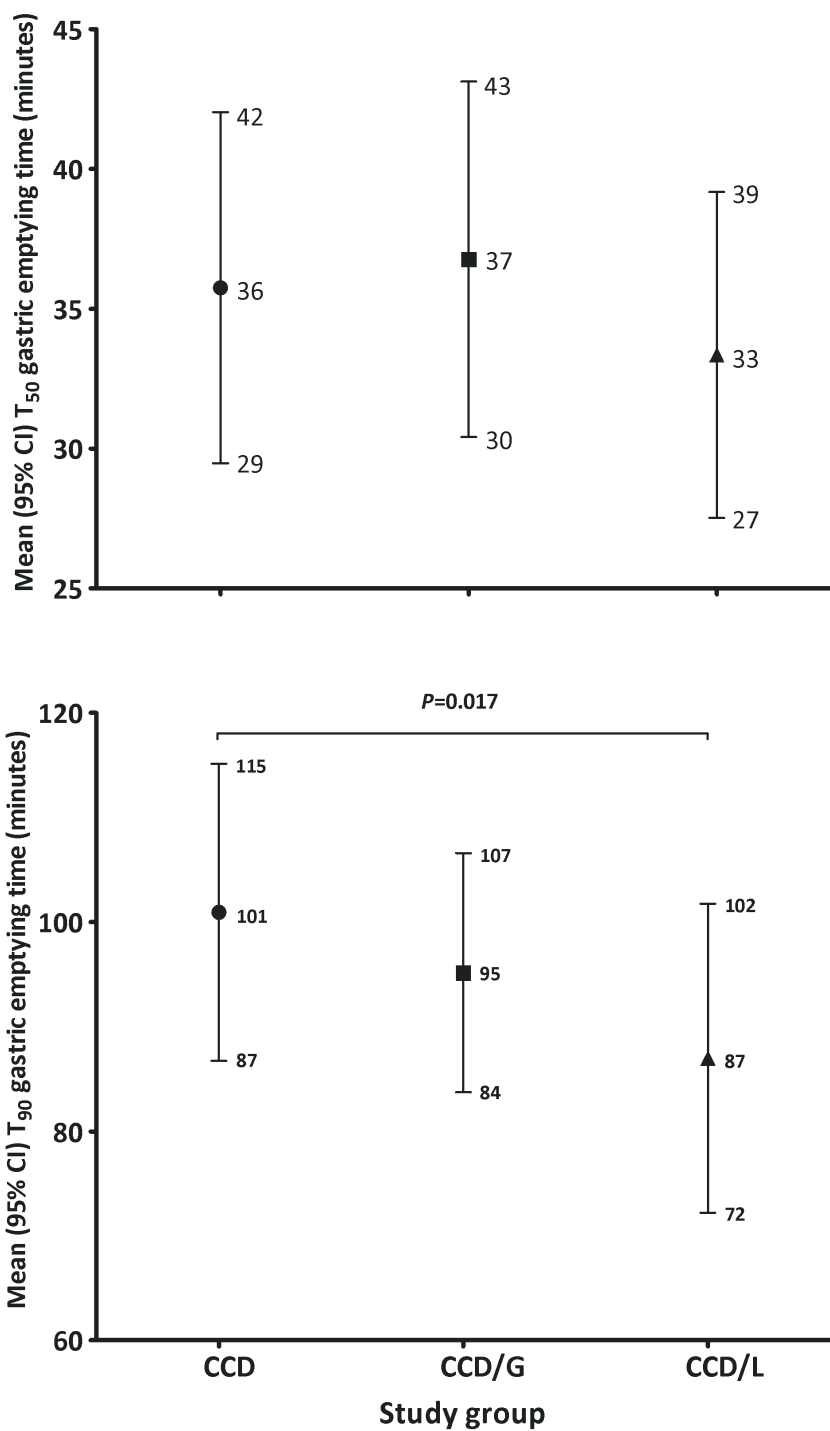
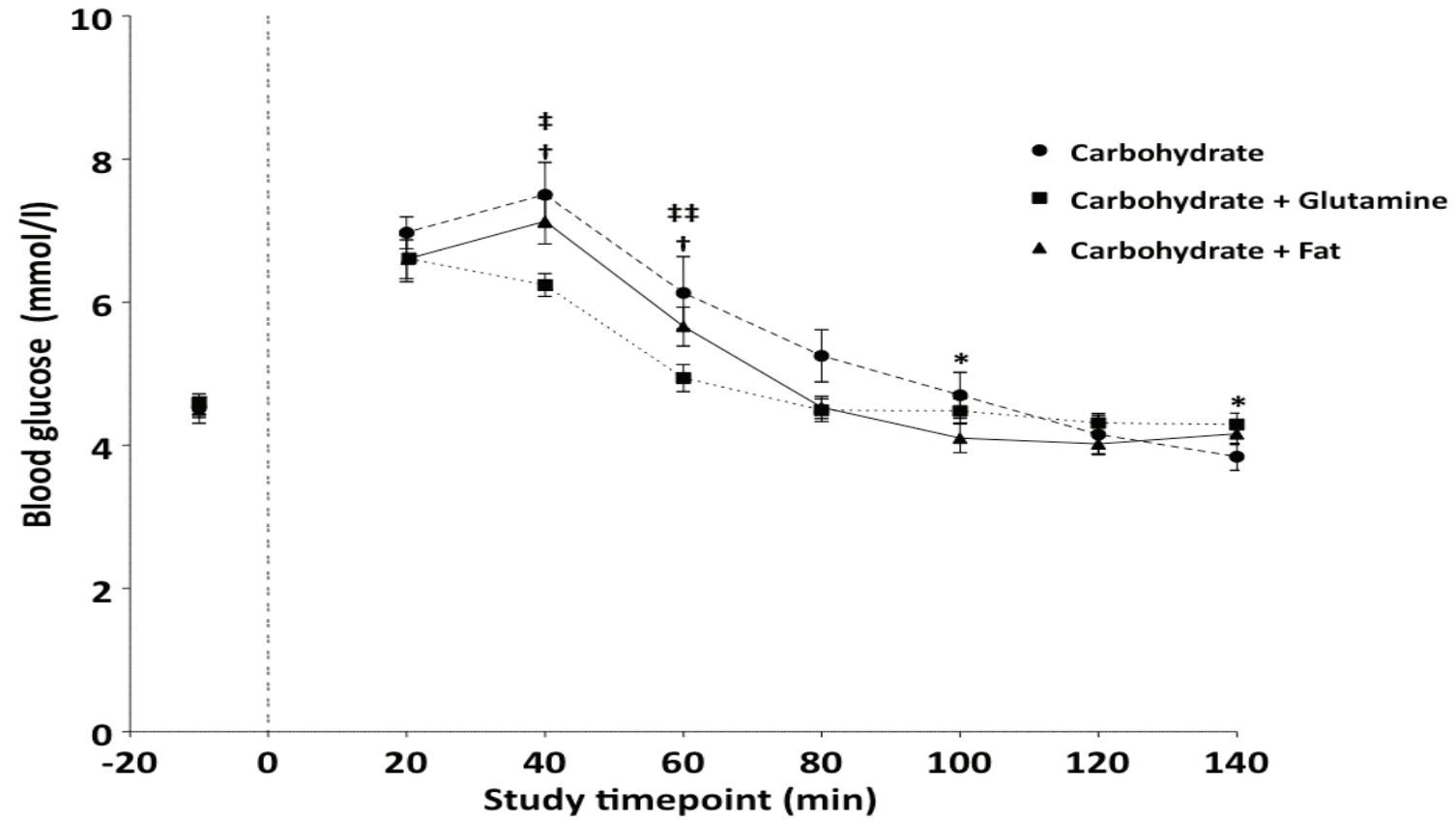

Figure 7.2: T₅₀ (top) and T₉₀ (bottom) gastric emptying times for the carbohydrate only (CCD), carbohydrate & glutamine (CCG/G), and carbohydrate & lipid drinks (CCD/L). N = 10.

7.3.2 Glucose, insulin and GLP-1 concentrations

Blood glucose concentrations peaked at 40 min for CCD and CCD/L before declining to baseline concentrations at 100 min (Figure 7.3A). Ingestion of the CCD/G drink was associated with a 'blunted' glucose response compared to the other two drinks, with a lower glucose peak at 40 min [6.2 (0.2) mmol/L]. There were no differences between the three drinks in peak insulin concentrations at 40 min, although there was a slower decline to baseline insulin concentrations following ingestion of CCD (Figure 7.3B). Finally, there were no differences in postprandial plasma GLP-1 concentrations between the three study drinks (Figure 7.3C).

A:



B:

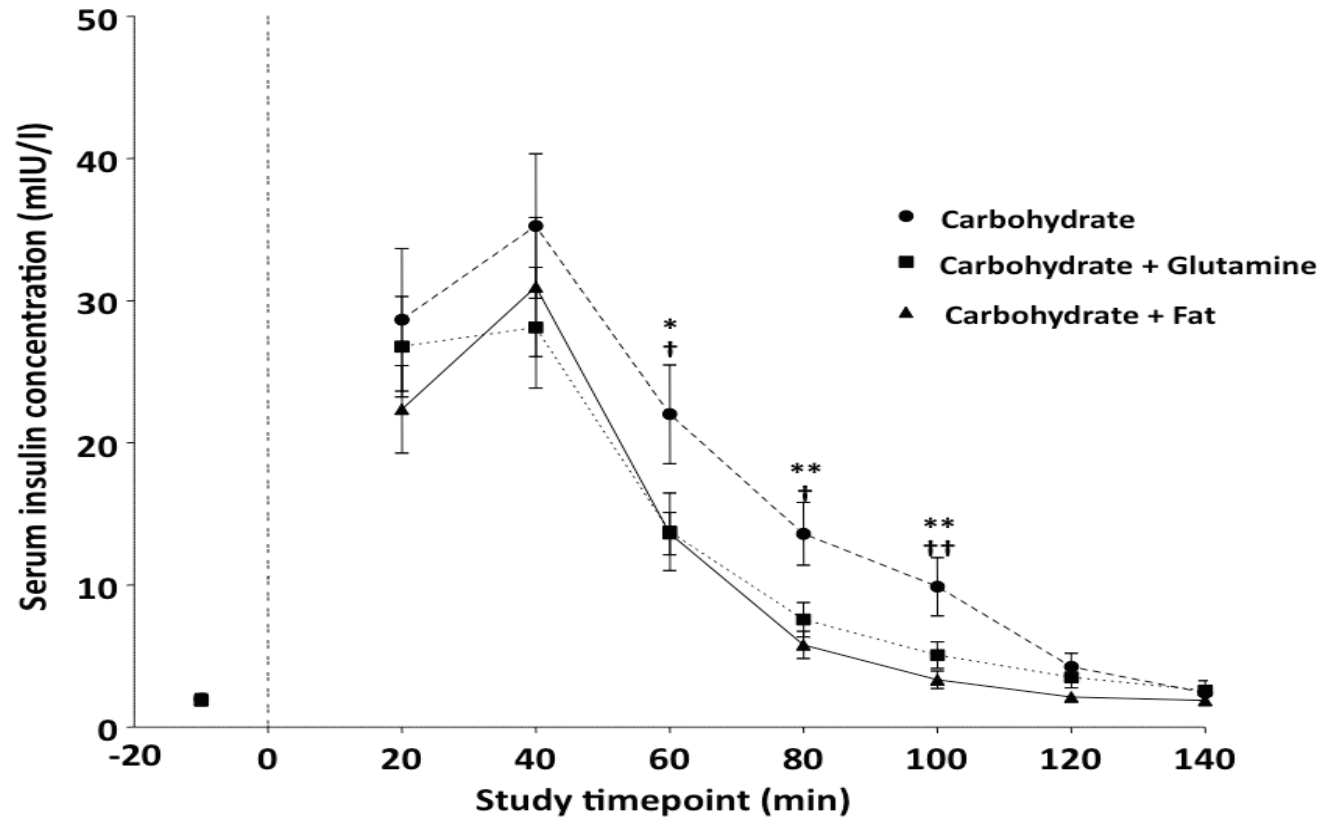

C:

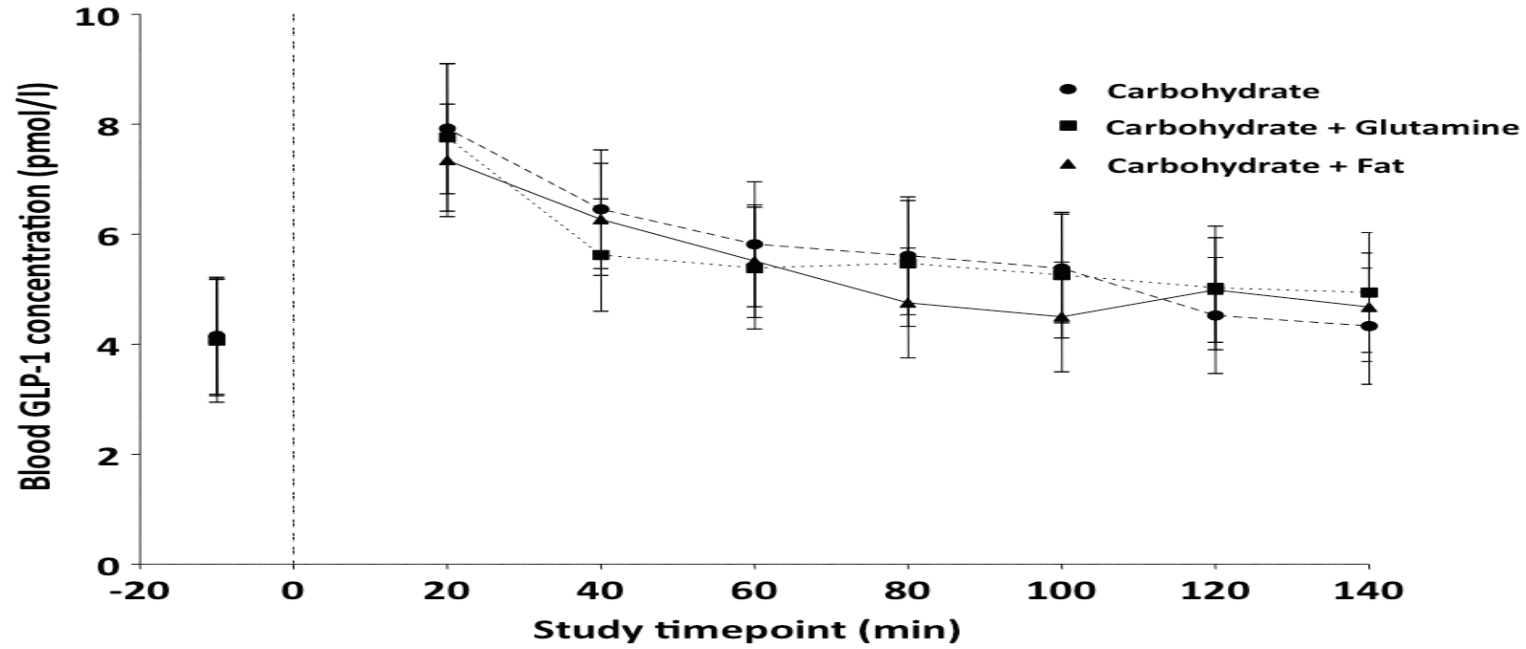

Figure 7.3: Blood glucose (A), insulin (B) and glucagon-like peptide 1 (C) concentrations following ingestion of the three study drinks (carbohydrate only [CCD], carbohydrate & glutamine [CCD/G], and carbohydrate & lipid [CCD/L]). N = 10. * $P < 0.05$ and ** $P < 0.01$ for CCD vs CCD/L; † $P < 0.05$ and †† $P < 0.01$ for CCD vs CCD/G; ‡ $P < 0.05$ and ‡‡ $P < 0.01$ for CCD/G vs CCD/L.

7.4 Discussion

This study in healthy volunteers has demonstrated that, contrary to current literature, the addition of glutamine or lipid to a 'preoperative' carbohydrate drink did not result in delayed gastric emptying. Supplementing the carbohydrate-drink with glutamine did, however, lead to 'blunted' postprandial glucose and insulin responses but these, together with the gastric emptying characteristics, did not result from differences in the magnitude of postprandial GLP-1 concentrations between the different drinks.

The methodology in the present study used drinks designed to allow the study of the effects on gastric emptying of supplementing a 'preoperative' carbohydrate-based drink with glutamine, the lipid-containing drink being utilised as a 'positive control' for delayed gastric emptying. All three drinks were isocaloric and isovolumetric thus eliminating potential confounding effects on gastric emptying from these variables (Houghton *et al.*, 1990). The distribution of the isotope within the drinks was homogenous over the period of study with no evidence of 'settling' or separation of the drinks' constituents, as indicated by the 'stability' experiments with and without simulated gastric fluid. Only males were included in order to eliminate the confounding effects of hormonal changes during the menstrual cycle (Lobo *et al.*, 2002; Brennan *et al.*, 2009). Whilst it would have been clinically advantageous to undertake the present study in patients undergoing surgery, the latter would have precluded a crossover design and could have been confounded by differing patient co-morbidities or the ingestion

of drugs that altered gastric emptying rates. The volunteers would not have experienced 'preoperative anxiety' encountered in clinical practice, however, the former was previously shown not to delay gastric emptying rates (Nygren *et al.*, 1995). Finally, although gastric scintigraphy measures the rate of emptying of the isotope from the stomach and is regarded as the gold-standard technique for measuring gastric emptying (Collins *et al.*, 1983), it provides little information on gastric secretions induced by nutrient ingestion, the latter contributing to total gastric volumes which are easier to quantify by magnetic resonance imaging (Lobo *et al.*, 2009).

The CCD had the longest gastric emptying time, the latter likely to have resulted from the high carbohydrate content of the drink of the drink (Vist and Maughan, 1995). The addition of glutamine to preOp® (CCD/G), whilst maintaining isocaloricity, markedly increased the osmolality above that of CCD, yet this did not delay gastric emptying. It is therefore likely that gastric emptying is more dependent on carbohydrate content rather than osmolality *per se* (Vist and Maughan, 1995). The isocaloric CCD/L had the lowest osmolality and, contrary to what was expected (Houghton *et al.*, 1990), emptied faster than the other two drinks. This may have occurred as a result of the CCD/L drink having a lower osmolality or there being too small a quantity of lipid to lead to significant delay in gastric emptying (Sidery *et al.*, 1994; Vist and Maughan, 1995). Although contrary to our *in vitro* 'stability' experiments, it is also possible that the CCD/L separated into lipid-depleted 'aqueous' and lipid layers thereby allowing the lipid-depleted layer to empty rapidly (Marciani *et al.*, 2006). Finally, the

behaviour of lipids ingested in the liquid phase may differ from those ingested in the solid phase (Cunningham and Read, 1989). A previous healthy volunteer study demonstrated little differences in the gastric emptying times of liquid isocaloric drinks that contained carbohydrate and those that additionally contained medium chain triglycerides (Vist and Maughan, 1995). However, the aforementioned study measured gastric emptying by the modified double sampling technique (Vist and Maughan, 1995) The novel findings from this scintigraphic study raise the possibility that the formulation and palatability of the carbohydrate-based preconditioning drinks currently administered to patients may be further improved by the addition of lipid thereby reducing osmolality and subsequent gastric emptying times whilst maintaining nutritional content.

The postprandial glucose and insulin responses of CCD were similar to those demonstrated in Chapter 6 namely, a rapid peak in glucose and insulin concentrations occurring within 40 min followed by a rapid decline back to baseline concentrations over the subsequent hour. Postprandial glucose and insulin concentrations were highest following CCD (preOp®) probably as a result of it containing the greatest quantity of carbohydrate (50.4 g) compared to the other two drinks (36 g). Ingestion of glutamine 'blunted' postprandial glucose and insulin responses, in line the study in chapter 6 where preOp® was compared to ONS. However, contrary to our previous hypotheses these blunted responses did not result from delayed gastric emptying. Furthermore, previous

human studies have demonstrated that glutamine supplementation increased postprandial and post-exercise insulin-mediated glucose disposal without elevating plasma insulin (Borel et al., 1998; Bowtell et al., 1999; Iwashita et al., 2005; Iwashita et al., 2006). Increased glucose disposal following CCD/G ingestion could, therefore, have resulted in lower plasma glucose concentrations. The latter effect may be utilized perioperatively whereby preoperative ingestion of a glutamine-containing drink may act to modulate and increase glucose disposal, over and above a carbohydrate-only drink, thereby reducing postoperative insulin resistance. However, the latter hypothesis requires further study by means of a hyperinsulinaemic-euglycaemic clamp.

Ingestion of the study drinks resulted in postprandial increases in plasma GLP-1, however, there were no differences in the magnitude of GLP-1 responses between the different drinks. A previous study that examined the effects of oral glutamine ingestion demonstrated increased postprandial GLP-1 concentrations associated with increased insulin concentrations (Greenfield et al., 2009). The aforementioned findings raised the possibility that oral glutamine may be used as a novel therapeutic approach to stimulate insulin secretion (Greenfield et al., 2009). Within the context of preoperative conditioning using carbohydrate-based drinks, the addition of glutamine would, therefore, have been expected to further augment insulin release over that achieved by carbohydrate loading alone. The results from the present study and that in Chapter 6 have failed to demonstrate this potentially beneficial metabolic effect of glutamine ingestion.

A potential limitation of this study was the use of corn oil which consisted of a mixture of polyunsaturated, monounsaturated and saturated fatty acids. The use of a purer preparation of a single chain length lipid would have improved the design of the study.

In conclusion, this study has demonstrated that the addition of glutamine or lipid to a 'preoperative' carbohydrate conditioning drink did not delay gastric emptying, but did 'blunt' postprandial glucose and insulin responses. These effects were not related to differences in postprandial GLP-1 concentrations. In addition, as all three drinks had a T_{90} of less than 2 hours, future patient studies should examine whether the addition of similar amounts of glutamine or lipid to clear carbohydrate drinks would allow for safe administration up to 2 hours preoperatively.

Chapter 8

Critique of thesis

Numerous scientific and clinical studies, undertaken in the last two decades, have demonstrated the beneficial effects of preoperative carbohydrate loading, as opposed to traditional preoperative fasting, in healthy non-diabetic patients undergoing elective surgery (Chapter 1). Ingestion of drinks containing 50 grams of carbohydrate, up to 90 min prior to induction of anaesthesia, attenuated the development of postoperative insulin resistance by up to 50% {Ljungqvist, 2004 #643}. This was associated with improved postoperative whole-body protein balance (Svanfeldt *et al.*, 2007), with better postoperative preservation of muscle mass (Yuill *et al.*, 2005) and function (Henriksen *et al.*, 2003), than in traditionally starved patients. Carbohydrate preconditioned patients also experienced less nausea, vomiting and anxiety perioperatively (Diks *et al.*, 2005; Hausel *et al.*, 2005). Furthermore, retrospective analysis of a number of studies demonstrated shortened length of hospital stay (Thorell *et al.*, 1999b) although this reduction was not statistically significant in a recent randomised controlled trial of patients undergoing elective colorectal and liver resections (Mathur *et al.*, 2010). This intervention (preoperative conditioning with carbohydrate-based drinks) has been incorporated into enhanced recovery after surgery programs that aimed to minimise metabolic stress and speed recovery after major surgery (Lassen *et al.*, 2009). However, the cellular effects that underlie the adverse effects of preoperative fasting, and conversely, the beneficial effects of preoperative conditioning with carbohydrate-based drinks remained unknown.

This thesis has demonstrated, using magnetic resonance spectroscopy, that ingestion of a 'preoperative' carbohydrate-based conditioning drink, that also

contained glutamine and antioxidants (ONS), following a 24 hour fast replenished liver glycogen reserves by 47% within 2 hours of ingestion (Chapter 4). Whilst this physiologically beneficial effect could ensure the availability of easily utilisable energy reserves in times of increased need (Chapter 1), such as metabolic-stress following surgery, it is likely that these liver reserves would be depleted within 24 hours. Therefore increased liver glycogen *per se* is unlikely to contribute mechanistically to the marked attenuation of postoperative insulin resistance seen following preconditioning with carbohydrate-based drinks. The development of insulin resistance is more likely to occur secondary to alterations in skeletal muscle metabolism, given that muscle is the main site of glucose disposal following an oral carbohydrate load. In line with previous investigators (Briet and Jeejeebhoy, 2001; Briet et al., 2003b; Briet et al., 2003a; Briet et al., 2004), we used PBMC mitochondrial membrane complex activity as a surrogate marker of what might occur in muscle following a 24-hour fast, followed by ingestion of a carbohydrate-based conditioning drink (ONS). Accordingly, we demonstrated that a 24-hour fast adversely affected PBMC MMC activity, resulting in significantly reduced MMC I (-72%), II (-49%) and IV (-41%) activities. We did not demonstrate that refeeding with the carbohydrate-based conditioning drink reversed these effects in PBMC mitochondria, however, the sampling time point chosen may not have been optimal. Similarly, the effects of this protocol on skeletal muscle MMC activity remain unknown – the latter would have required at least four sets of muscle biopsies within a period of 24-hours which may have raised ethical concerns in this healthy volunteer study

(Chapter 4). Nonetheless, the novel finding of markedly decreased PBMC MMC activity after this short period of fasting (24 hours) may be of clinical significance should it result in weakened immune responses. Finally, this study also demonstrated a 23% increase in IMCL concentrations following a 24 hour fast. Volunteers were encouraged to drink water *ad libitum* so it is unlikely that alterations in muscle water concentrations would have resulted in a spurious result. Furthermore, previous investigators demonstrated a 175% increase in IMCL concentrations (Johnson et al., 2006) following a 67 hour fast – the latter correlating negatively with insulin sensitivity (measured by the intravenous glucose tolerance test). The mechanisms underlying this effect remain unclear. Elevated plasma FFA, seen following a prolonged period of fasting (Tsintzas et al., 2007), are one of the determinants of the rate of muscle fat oxidation via the glucose-fatty acid cycle (Frayn, 1999). However, in healthy volunteers it would be expected that there would be sufficient mitochondrial capacity to oxidise increased concentrations of fatty acids, thereby limiting substantial elevations in IMCL concentrations. As previously described, the accumulation of IMCL metabolites could interfere with insulin signalling thereby inducing ‘lipid-induced insulin resistance’ (Petersen and Shulman, 2006). However, it is of note that the latter hypothesis is based on studies of long-term IMCL elevation (such as in patients with type 2 diabetes), in contrast to the reversible effects reported in healthy volunteers following short-term fasting. Further studies would therefore be needed to characterise muscle mitochondrial complex activity, carbohydrate

and fat oxidative capacity following 12 and 24-hour fasts, followed by refeeding with these preconditioning drinks.

In patients undergoing elective laparoscopic cholecystectomy, preoperative ingestion of a carbohydrate-based conditioning drink was well tolerated and resulted in increased intraoperative liver glycogen concentrations (Chapter 5). This study also demonstrated that the additional constituents (glutamine and antioxidants) were absorbed and led to increased plasma concentrations both intra- and postoperatively. Larger appropriately powered clinical studies would be needed to demonstrate whether preoperative ingestion of these additional conditioning agents (glutamine and antioxidants) resulted in clinical benefits (decreased morbidity or mortality). An improved experimental design would have investigated each component of the preconditioning drink (ONS) separately (carbohydrate *versus* glutamine *versus* antioxidants), however, the study in Chapter 5 was designed as a 'pilot study' that would power future clinical studies investigating the clinical efficacy of preconditioning with ONS. Nevertheless, this study did reveal novel changes at the level of gene and protein expression. Preoperative conditioning with the carbohydrate-based drink resulted in a 4-fold and 44% lower expression of PDK4 mRNA and protein in the intervention group. A previous healthy volunteer study from our laboratory (Tsintzas et al., 2006) reported the effects of a 48-hour fast on PDK4 mRNA expression. In the aforementioned study a 48-hour fast resulted in a 4-fold higher expression of PDK4 mRNA compared to baseline (overnight fast). The placebo group in the patient study described in Chapter 5 would have encountered a degree of

metabolic-stress following a 12-18 hour period of fasting, anaesthetic induction, the insertion of laparoscopic ports and CO₂ pneumoperitoneum. Even this magnitude of metabolic-stress resulted in significantly greater PDK4 mRNA and protein expression than that reported in the ONS-preconditioned group. PDK4 is one of the main regulators of PDC activity which plays a key role in muscle carbohydrate metabolism (Chapter 5). We demonstrated that the beneficial effects of preoperative carbohydrate loading were associated with lower PDK4 expression which may have 'permitted' PDC activity and carbohydrate oxidation. However, further studies need to examine how these intraoperative differences in the mechanisms regulating PDC activity lead to such marked reductions in postoperative insulin sensitivity. Future studies should also examine novel methods of optimising perioperative PDC activity with a view to maintaining carbohydrate oxidation in peripheral tissues. It is of note that there were no differences between the two groups (ONS and placebo) in mitochondrial function, as defined by MMC activity, β -HAD activity and ATP concentrations. However, it is possible that the intraoperative muscle sampling time point may have been too early to detect differences in mitochondrial enzyme activities (as changes were occurring at the level of gene and protein expression). Later sampling time points e.g. 12 and 24 hours postoperatively would have provided an elegant analysis of whether these changes at gene and protein expression translated to differences in enzyme activity. Finally, reduced cellular oxidative stress in the ONS-preconditioned group may have resulted from decreased FFA oxidation (reduced generation of ROS) or from the antioxidant constituents of

the drink. Future studies should determine the cellular and clinical relevance (decreased morbidity) of this finding.

The aforementioned differences in gene and protein expression were demonstrated following preconditioning with ONS. It is possible, however, that ingestion of preOp® would have resulted in a greater magnitude of effects at gene and protein expression level, as a result of higher postprandial insulin and glucose concentrations (Chapter 6). Both drinks contained 50 grams of carbohydrate yet the postprandial glucose and insulin responses differed markedly. Ingestion of preOp® was associated with higher peaks in postprandial glucose and insulin concentrations, with concentrations decreasing rapidly to baseline within 80 min. In contrast, ONS ingestion was associated with blunted postprandial responses with concentrations of insulin remaining higher than preOp® at 100 min. These ‘blunted’ postprandial responses may be clinically useful in patients with impaired glucose tolerance as the latter may not tolerate the rapid changes in glucose and insulin concentrations following preOp® (in several healthy volunteers postprandial blood glucose concentrations of 10-11 mmol/L were recorded following preOp®).

An elegant study by Svanfeldt *et al* (Svanfeldt et al., 2005) demonstrated that the ‘preoperative’ serving of the carbohydrate-based drink increased peripheral insulin sensitivity by 50%. However, it remains unknown whether the beneficial effects of preconditioning with carbohydrate-based drinks arose from elevated insulin or glucose concentrations, or both, close to the onset of surgical stress.

Similarly, it remains to be known whether a 'minimal threshold' of postprandial insulin release is required preoperatively to reduce postoperative insulin resistance. The study outlined in Chapter 6 demonstrated that 120 min after ingestion of both preconditioning drinks (ONS and preOp®), the clinical time point following which patients would undergo anaesthetic induction, postprandial insulin and glucose concentrations had returned to baseline. Thus any beneficial effects of preoperative carbohydrate loading using these drinks, demonstrated in previous studies, are unlikely to result from the presence of elevated insulin concentrations at the onset of surgical stress. It is of note, however, that the only study of preoperative carbohydrate loading *per se* to have demonstrated a near complete attenuation of the postoperative insulin resistance response (Nygren et al., 1998b) utilised a hyperinsulinaemic-euglycaemic clamp. It is likely, therefore, that the mechanism of action of these preconditioning drinks is mainly via an insulin effect at the level of peripheral tissues (skeletal muscle). Further increasing endogenous insulin release, for example by means of an intraoperative infusion of 10% dextrose may lead to further attenuation of postoperative insulin resistance. Use of the latter would reduce the risk of thrombophlebitis (Chapter 1), but lead to sufficient release of endogenous insulin to stimulate carbohydrate oxidation.

Ingestion of glutamine as part of a preconditioning regimen resulted in 'blunted' glucose and insulin responses but did not, as hypothesised, delay gastric emptying (Chapter 7). The mechanisms underlying this effect of glutamine on insulin and glucose homeostasis are worthy of further study given that glutamine

supplementation resulted in improved metabolic control and decreased insulin resistance in critically ill patients (Dechelotte et al., 2006). Our study also demonstrated that glutamine ingestion, contrary to findings from a previous study (Greenfield et al., 2009), did not augment glucose-induced insulin release. The latter would have been a physiologically beneficial effect given the aforementioned discussion of the benefits of elevated perioperative insulin concentrations. Glutamine ingestion did, however, increase intraoperative plasma glutamine concentrations and tended to increase muscle glutamine reserves (Chapter 5) but further studies would be needed to investigate whether this leads to reduced morbidity in patients undergoing elective surgery. The 'blunted' postprandial glucose responses may also have resulted from a glutamine-induced increase in glucose utilization {Iwashita, 2006 #577;Iwashita, 2005 #786}, thereby reducing plasma glucose concentrations. The latter hypothesis if true, would increase glucose sensitivity over and above that achieved by carbohydrate loading alone, and this may result in reduced postoperative morbidity {Sato, 2010 #789}.

Finally, the gastric emptying of these preconditioning drinks was more dependent on carbohydrate content than macronutrient composition (Chapter 7). Contrary to current hypotheses (Houghton et al., 1990), the addition of lipid to the formulation of these drinks did not result in delayed gastric emptying. This raises the possibility of further optimising the designs of these drinks to optimise energy content, osmolality and palatability.

Chapter 9

Future directions

The studies described in this thesis have helped define some of the mechanisms underlying the adverse effects of short-term fasting and beneficial effects of preoperative loading with carbohydrate-based drinks. However, the work undertaken thus far has also identified many new questions that we hope to address in future studies:

1. Whether the decrease in mononuclear cell mitochondrial complex activity, following short-term fasting, leads to altered mononuclear cell function (e.g. NK cell activity or altered bacterial killing).
2. Whether this decrease in mononuclear cell mitochondrial complex activity following short-term fasting also occurs in skeletal muscle mitochondria.
3. The individual components of ONS (carbohydrate, glutamine and antioxidants) should be studied separately to ascertain the beneficial effects of each constituent and therefore further optimise these drinks.
4. The effects of preoperative ingestion of carbohydrate drinks on PDC activity should be studied, along with the cellular and molecular pathways by which alterations in PDC activity leads to improved insulin sensitivity.
5. New modalities of stimulating perioperative PDC activity, and therefore carbohydrate oxidation, should be studied. An example of such a novel modality includes intraoperative electrical stimulation of large muscle

groups (known to lead to intracellular calcium release, the latter a stimulant of PDC activity).

6. Insulin clamp studies should be undertaken to determine whether there are differences in postprandial insulin sensitivity following the ingestion of preOp® and ONS and whether glutamine supplementation of these drinks increases glucose disposal over and above that by carbohydrate ingestion alone.
7. The effects on postprandial glucose and insulin concentrations of the differing carbohydrate types contained in preOp® and ONS should be studied.
8. New formulations of these preoperative drinks should utilise novel carbohydrates mixtures that are slowly broken down thereby leading to prolonged insulin release.
9. Finally, the design and ingredients of these preoperative drinks could be further improved by including nutrients to improve caloric content and palatability.

Bibliography

- Accili D and Arden KC (2004). FoxOs at the crossroads of cellular metabolism, differentiation, and transformation. *Cell* **117**:421-426.
- Aghdassi E and Allard JP (2000). Breath alkanes as a marker of oxidative stress in different clinical conditions. *Free Radic Biol Med* **28**:880-886.
- Agwunobi AO, Reid C, Maycock P, Little RA and Carlson GL (2000). Insulin resistance and substrate utilization in human endotoxemia. *J Clin Endocrinol Metab* **85**:3770-3778.
- Akintola DF, Sampson B, Burrin J, Fleck A, Price C and Hall G (1997). Changes in plasma metallothionein-1, interleukin-6, and C-reactive protein in patients after elective surgery. *Clin Chem* **43**:845-847.
- Alger JR, Sillerud LO, Behar KL, Gillies RJ, Shulman RG, Gordon RE *et al.* (1981). In vivo carbon-13 nuclear magnetic resonance studies of mammals. *Science* **214**:660-662.
- Alibegovic A and Ljungqvist O (1993). Pretreatment with glucose infusion prevents fatal outcome after hemorrhage in food deprived rats. *Circ Shock* **39**:1-6.
- Allison SP and Go VLW (2004). Metabolic issues of clinical nutrition, Karger ; Nestle Nutrition, Basel; Switzerland.
- Ardawi MS, Majzoub MF, Masoud IM and Newsholme EA (1989). Enzymic and metabolic adaptations in the gastrocnemius, plantaris and soleus muscles of hypocaloric rats. *Biochem J* **261**:219-225.

- Baines M and Shenkin A (2002). Use of antioxidants in surgery: a measure to reduce postoperative complications. *Curr Opin Clin Nutr Metab Care* **5**:665-670.
- Bakalar B, Duska F, Pacht J, Fric M, Otahal M, Pazout J *et al.* (2006). Parenterally administered dipeptide alanyl-glutamine prevents worsening of insulin sensitivity in multiple-trauma patients. *Crit Care Med* **34**:381-386.
- Baker SP, O'Neill B, Haddon W, Jr. and Long WB (1974). The injury severity score: a method for describing patients with multiple injuries and evaluating emergency care. *J Trauma* **14**:187-196.
- Bark T, Katouli M, Svenberg T and Ljungqvist O (1995). Food deprivation increases bacterial translocation after non-lethal haemorrhage in rats. *Eur J Surg* **161**:67-71.
- Basciano H, Federico L and Adeli K (2005). Fructose, insulin resistance, and metabolic dyslipidemia. *Nutr Metab (Lond)* **2**:5.
- Berger MM and Chioloro RL (2007). Antioxidant supplementation in sepsis and systemic inflammatory response syndrome. *Crit Care Med* **35**:S584-590.
- Bergstrom J and Hultman E (1967). A study of the glycogen metabolism during exercise in man. *Scand J Clin Lab Invest* **19**:218-228.
- Birch-Machin MA, Briggs HL, Saborido AA, Bindoff LA and Turnbull DM (1994). An evaluation of the measurement of the activities of complexes I-IV in the respiratory chain of human skeletal muscle mitochondria. *Biochem Med Metab Biol* **51**:35-42.

- Bisgaard T, Kristiansen VB, Hjortso NC, Jacobsen LS, Rosenberg J and Kehlet H (2004). Randomized clinical trial comparing an oral carbohydrate beverage with placebo before laparoscopic cholecystectomy. *Br J Surg* **91**:151-158.
- Blaak EE, Hul G, Verdich C, Stich V, Martinez A, Petersen M *et al.* (2006). Fat oxidation before and after a high fat load in the obese insulin-resistant state. *J Clin Endocrinol Metab* **91**:1462-1469.
- Black PR, Brooks DC, Bessey PQ, Wolfe RR and Wilmore DW (1982). Mechanisms of insulin resistance following injury. *Ann Surg* **196**:420-435.
- Boirie Y (2003). Insulin regulation of mitochondrial proteins and oxidative phosphorylation in human muscle. *Trends Endocrinol Metab* **14**:393-394.
- Boirie Y, Short KR, Ahlman B, Charlton M and Nair KS (2001). Tissue-specific regulation of mitochondrial and cytoplasmic protein synthesis rates by insulin. *Diabetes* **50**:2652-2658.
- Borel MJ, Williams PE, Jabbour K, Levenhagen D, Kaizer E and Flakoll PJ (1998). Parenteral glutamine infusion alters insulin-mediated glucose metabolism. *JPEN J Parenter Enteral Nutr* **22**:280-285.
- Bowtell JL, Gelly K, Jackman ML, Patel A, Simeoni M and Rennie MJ (1999). Effect of oral glutamine on whole body carbohydrate storage during recovery from exhaustive exercise. *J Appl Physiol* **86**:1770-1777.
- Boyum A (1968). Isolation of mononuclear cells and granulocytes from human blood. Isolation of monuclear cells by one centrifugation, and of

granulocytes by combining centrifugation and sedimentation at 1 g.

Scand J Clin Lab Invest Suppl **97**:77-89.

Bradford MM (1976). A rapid and sensitive method for the quantitation of microgram quantities of protein utilizing the principle of protein-dye binding. *Anal Biochem* **72**:248-254.

Brady LJ and Hoppel CL (1983). Effect of diet and starvation on hepatic mitochondrial function in the rat. *J Nutr* **113**:2129-2137.

Brady M, Kinn S and Stuart P (2003). Preoperative fasting for adults to prevent perioperative complications. *Cochrane Database Syst Rev*:CD004423.

Braga M, Gianotti L, Radaelli G, Vignali A, Mari G, Gentilini O *et al.* (1999). Perioperative immunonutrition in patients undergoing cancer surgery: results of a randomized double-blind phase 3 trial. *Arch Surg* **134**:428-433.

Brandi LS, Frediani M, Oleggini M, Mosca F, Cerri M, Boni C *et al.* (1990). Insulin resistance after surgery: normalization by insulin treatment. *Clin Sci (Lond)* **79**:443-450.

Brandi LS, Santoro D, Natali A, Altomonte F, Baldi S, Frascerra S *et al.* (1993). Insulin resistance of stress: sites and mechanisms. *Clin Sci (Lond)* **85**:525-535.

Brennan IM, Feltrin KL, Nair NS, Hausken T, Little TJ, Gentilcore D *et al.* (2009). Effects of the phases of the menstrual cycle on gastric emptying, glycemia, plasma GLP-1 and insulin, and energy intake in healthy lean women. *Am J Physiol Gastrointest Liver Physiol* **297**:G602-610.

- Breuer JP, von Dossow V, von Heymann C, Griesbach M, von Schickfus M, Mackh E *et al.* (2006). Preoperative oral carbohydrate administration to ASA III-IV patients undergoing elective cardiac surgery. *Anesth Analg* **103**:1099-1108.
- Briet F and Jeejeebhoy KN (2001). Effect of hypoenergetic feeding and refeeding on muscle and mononuclear cell activities of mitochondrial complexes I-IV in enterally fed rats. *Am J Clin Nutr* **73**:975-983.
- Briet F, Twomey C and Jeejeebhoy KN (2003a). Effect of malnutrition and short-term refeeding on peripheral blood mononuclear cell mitochondrial complex I activity in humans. *Am J Clin Nutr* **77**:1304-1311.
- Briet F, Twomey C and Jeejeebhoy KN (2003b). Relationship between metabolism and peripheral blood mononuclear cell mitochondrial complex I activity before and after a short-term refeeding in weight-losing cancer patients. *Clin Nutr* **22**:247-253.
- Briet F, Twomey C and Jeejeebhoy KN (2004). Effect of feeding malnourished patients for 1 mo on mitochondrial complex I activity and nutritional assessment measurements. *Am J Clin Nutr* **79**:787-794.
- Brooks DC, Black PR, Arcangeli MA, Aoki TT and Wilmore DW (1989). The heated dorsal hand vein: an alternative arterial sampling site. *JPEN J Parenter Enteral Nutr* **13**:102-105.
- Brozinick JT, Jr., Roberts BR and Dohm GL (2003). Defective signaling through Akt-2 and -3 but not Akt-1 in insulin-resistant human skeletal muscle: potential role in insulin resistance. *Diabetes* **52**:935-941.

- Carey PE, Halliday J, Snaar JE, Morris PG and Taylor R (2003). Direct assessment of muscle glycogen storage after mixed meals in normal and type 2 diabetic subjects. *Am J Physiol Endocrinol Metab* **284**:E688-694.
- Carlson GL (2003). Insulin resistance in sepsis. *Br J Surg* **90**:259-260.
- Carlson GL (2004). Hunterian Lecture: Insulin resistance in human sepsis: implications for the nutritional and metabolic care of the critically ill surgical patient. *Ann R Coll Surg Engl* **86**:75-81.
- Casey A, Mann R, Banister K, Fox J, Morris PG, Macdonald IA *et al.* (2000). Effect of carbohydrate ingestion on glycogen resynthesis in human liver and skeletal muscle, measured by (13)C MRS. *Am J Physiol Endocrinol Metab* **278**:E65-75.
- Chi MM, Hintz CS, Coyle EF, Martin WH, 3rd, Ivy JL, Nemeth PM *et al.* (1983). Effects of detraining on enzymes of energy metabolism in individual human muscle fibers. *Am J Physiol* **244**:C276-287.
- Cho ES, Sahyoun N and Stegink LD (1981). Tissue glutathione as a cyst(e)ine reservoir during fasting and refeeding of rats. *J Nutr* **111**:914-922.
- Collins PJ, Horowitz M, Cook DJ, Harding PE and Shearman DJ (1983). Gastric emptying in normal subjects--a reproducible technique using a single scintillation camera and computer system. *Gut* **24**:1117-1125.
- Connaughton S, Chowdhury F, Attia RR, Song S, Zhang Y, Elam MB *et al.* (2009). Regulation of pyruvate dehydrogenase kinase isoform 4 (PDK4) gene expression by glucocorticoids and insulin. *Mol Cell Endocrinol* **315**:159-167.

- Crossland H, Constantin-Teodosiu D, Gardiner SM, Constantin D and Greenhaff PL (2008). A potential role for Akt/FOXO signalling in both protein loss and the impairment of muscle carbohydrate oxidation during sepsis in rodent skeletal muscle. *J Physiol* **586**:5589-5600.
- Cunningham KM and Read NW (1989). The effect of incorporating fat into different components of a meal on gastric emptying and postprandial blood glucose and insulin responses. *Br J Nutr* **61**:285-290.
- Cuthbertson DP (1980a). Alterations in metabolism following injury: part I. *Injury* **11**:175-189.
- Cuthbertson DP (1980b). Alterations in metabolism following injury: part II. *Injury* **11**:286-303.
- Daly ME, Vale C, Walker M, Alberti KG and Mathers JC (1997). Dietary carbohydrates and insulin sensitivity: a review of the evidence and clinical implications. *Am J Clin Nutr* **66**:1072-1085.
- Dechelotte P, Hasselmann M, Cynober L, Allaouchiche B, Coeffier M, Heeketsweiler B *et al.* (2006). L-alanyl-L-glutamine dipeptide-supplemented total parenteral nutrition reduces infectious complications and glucose intolerance in critically ill patients: the French controlled, randomized, double-blind, multicenter study. *Crit Care Med* **34**:598-604.
- Delogu G, Moretti S, Famularo G, Antonucci A, Signore L, Marcellini S *et al.* (2001a). Circulating neutrophils exhibit enhanced apoptosis associated with mitochondrial dysfunctions after surgery under general anaesthesia. *Acta Anaesthesiol Scand* **45**:87-94.

- Delogu G, Moretti S, Famularo G, Marcellini S, Santini G, Antonucci A *et al.* (2001b). Mitochondrial perturbations and oxidant stress in lymphocytes from patients undergoing surgery and general anesthesia. *Arch Surg* **136**:1190-1196.
- Diks J, van Hoorn DE, Nijveldt RJ, Boelens PG, Hofman Z, Bouritius H *et al.* (2005). Preoperative fasting: an outdated concept? *JPEN J Parenter Enteral Nutr* **29**:298-304.
- Domenicali M, Caraceni P, Vendemiale G, Grattagliano I, Nardo B, Dall'Agata M *et al.* (2001). Food deprivation exacerbates mitochondrial oxidative stress in rat liver exposed to ischemia-reperfusion injury. *J Nutr* **131**:105-110.
- Duchen MR (2004). Roles of mitochondria in health and disease. *Diabetes* **53 Suppl 1**:S96-102.
- Esahili AH, Boija PO, Ljungqvist O, Rubio C and Ware J (1991). Twenty-four hour fasting increases endotoxin lethality in the rat. *Eur J Surg* **157**:89-95.
- Essen P, Thorell A, McNurlan MA, Anderson S, Ljungqvist O, Wernerman J *et al.* (1995). Laparoscopic cholecystectomy does not prevent the postoperative protein catabolic response in muscle. *Ann Surg* **222**:36-42.
- Evans JL, Goldfine ID, Maddux BA and Grodsky GM (2002). Oxidative stress and stress-activated signaling pathways: a unifying hypothesis of type 2 diabetes. *Endocr Rev* **23**:599-622.
- Faria MS, de Aguilar-Nascimento JE, Pimenta OS, Alvarenga LC, Jr., Dock-Nascimento DB and Shesharenko N (2009). Preoperative fasting of 2 hours minimizes insulin resistance and organic response to trauma after

video-cholecystectomy: a randomized, controlled, clinical trial. *World J Surg* **33**:1158-1164.

Fearon KC, Ljungqvist O, Von Meyenfeldt M, Revhaug A, Dejong CH, Lassen K *et al.* (2005). Enhanced recovery after surgery: a consensus review of clinical care for patients undergoing colonic resection. *Clin Nutr* **24**:466-477.

Feldman M, Walsh JH, Wong HC and Richardson CT (1978). Role of gastrin heptadecapeptide in the acid secretory response to amino acids in man. *J Clin Invest* **61**:308-313.

Ferreira J and Gil L (1984). Nutritional effects on mitochondrial bioenergetics. Alterations in oxidative phosphorylation by rat liver mitochondria. *Biochem J* **218**:61-67.

Frayn KN (1999). *Metabolic Regulation : A Human Perspective*. Portland Press, London.

Friberg B, Heilborn B, Haggmark T and Ljungqvist O (1994). Food deprivation prior to stress reduces stimulated muscle force both before and after hemorrhage in the rat. *Surgical Research Communications* **16**:131-137.

Fryburg DA, Barrett EJ, Louard RJ and Gelfand RA (1990). Effect of starvation on human muscle protein metabolism and its response to insulin. *Am J Physiol* **259**:E477-482.

Fukumori T, Ohkohchi N, Tsukamoto S, Asakura T, Oikawa K, Takayama J *et al.* (1997). Long-term fasting of donors deteriorates mitochondrial adenosine triphosphate synthesis in liver grafts during cold preservation. *Transplant Proc* **29**:3360-3361.

- Furst P, Pollack L, Graser TA, Godel H and Stehle P (1990). Appraisal of four pre-column derivatization methods for the high-performance liquid chromatographic determination of free amino acids in biological materials. *J Chromatogr* **499**:557-569.
- Furuyama T, Kitayama K, Yamashita H and Mori N (2003). Forkhead transcription factor FOXO1 (FKHR)-dependent induction of PDK4 gene expression in skeletal muscle during energy deprivation. *Biochem J* **375**:365-371.
- Gaiani S, Bolondi L, Li Bassi S, Santi V, Zironi G and Barbara L (1989). Effect of meal on portal hemodynamics in healthy humans and in patients with chronic liver disease. *Hepatology* **9**:815-819.
- Gallen IW, Macdonald IA and Mansell PI (1990). The effect of a 48 h fast on the physiological responses to food ingestion in normal-weight women. *Br J Nutr* **63**:53-64.
- Gianotti L, Braga M, Biffi R, Bozzetti F and Mariani L (2009). Perioperative intravenous glutamine supplementation in major abdominal surgery for cancer: a randomized multicenter trial. *Ann Surg* **250**:684-690.
- Gianotti L, Braga M, Nespoli L, Radaelli G, Beneduce A and Di Carlo V (2002). A randomized controlled trial of preoperative oral supplementation with a specialized diet in patients with gastrointestinal cancer. *Gastroenterology* **122**:1763-1770.
- Greenfield JR, Farooqi IS, Keogh JM, Henning E, Habib AM, Blackwood A *et al.* (2009). Oral glutamine increases circulating glucagon-like peptide 1,

glucagon, and insulin concentrations in lean, obese, and type 2 diabetic subjects. *Am J Clin Nutr* **89**:106-113.

Gustafsson UO, Nygren J, Thorell A, Soop M, Hellstrom PM, Ljungqvist O *et al.* (2008). Pre-operative carbohydrate loading may be used in type 2 diabetes patients. *Acta Anaesthesiol Scand* **52**:946-951.

Hausel J, Nygren J, Lagerkranser M, Hellstrom PM, Hammarqvist F, Almstrom C *et al.* (2001). A carbohydrate-rich drink reduces preoperative discomfort in elective surgery patients. *Anesth Analg* **93**:1344-1350.

Hausel J, Nygren J, Thorell A, Lagerkranser M and Ljungqvist O (2005). Randomized clinical trial of the effects of oral preoperative carbohydrates on postoperative nausea and vomiting after laparoscopic cholecystectomy. *Br J Surg* **92**:415-421.

Hayakawa J, Motohashi H, Sairenji M, Kobayashi O, Takahashi M and Usuda Y (2000). The effects of intraoperative glucose infusion on portal blood insulin concentration and hepatic mitochondrial redox state during surgery: comparison of short-term and continuous infusions. *Surg Today* **30**:228-234.

Henriksen MG, Hessov I, Dela F, Hansen HV, Haraldsted V and Rodt SA (2003). Effects of preoperative oral carbohydrates and peptides on postoperative endocrine response, mobilization, nutrition and muscle function in abdominal surgery. *Acta Anaesthesiol Scand* **47**:191-199.

- Hill GL (1992). *Disorders of nutrition and metabolism in clinical surgery : understanding and management*. Churchill Livingstone, Edinburgh; New York.
- Horowitz M, Edelbroek MA, Wishart JM and Straathof JW (1993). Relationship between oral glucose tolerance and gastric emptying in normal healthy subjects. *Diabetologia* **36**:857-862.
- Houdijk AP, Rijnsburger ER, Jansen J, Wesdorp RI, Weiss JK, McCamish MA *et al.* (1998). Randomised trial of glutamine-enriched enteral nutrition on infectious morbidity in patients with multiple trauma. *Lancet* **352**:772-776.
- Houghton LA, Mangnall YF and Read NW (1990). Effect of incorporating fat into a liquid test meal on the relation between intragastric distribution and gastric emptying in human volunteers. *Gut* **31**:1226-1229.
- Houstis N, Rosen ED and Lander ES (2006). Reactive oxygen species have a causal role in multiple forms of insulin resistance. *Nature* **440**:944-948.
- Iwashita S, Mikus C, Baier S and Flakoll PJ (2006). Glutamine supplementation increases postprandial energy expenditure and fat oxidation in humans. *JPEN J Parenter Enteral Nutr* **30**:76-80.
- Iwashita S, Williams P, Jabbour K, Ueda T, Kobayashi H, Baier S *et al.* (2005). Impact of glutamine supplementation on glucose homeostasis during and after exercise. *J Appl Physiol* **99**:1858-1865.

- Jackson MJ, Papa S, Bolanos J, Bruckdorfer R, Carlsen H, Elliott RM *et al.* (2002). Antioxidants, reactive oxygen and nitrogen species, gene induction and mitochondrial function. *Mol Aspects Med* **23**:209-285.
- Jagoe RT, Lecker SH, Gomes M and Goldberg AL (2002). Patterns of gene expression in atrophying skeletal muscles: response to food deprivation. *FASEB J* **16**:1697-1712.
- Jensen MD, Haymond MW, Gerich JE, Cryer PE and Miles JM (1987). Lipolysis during fasting. Decreased suppression by insulin and increased stimulation by epinephrine. *J Clin Invest* **79**:207-213.
- Johnson NA, Stannard SR, Rowlands DS, Chapman PG, Thompson CH, O'Connor H *et al.* (2006). Effect of short-term starvation versus high-fat diet on intramyocellular triglyceride accumulation and insulin resistance in physically fit men. *Exp Physiol* **91**:693-703.
- Jones C, Palmer TE and Griffiths RD (1999). Randomized clinical outcome study of critically ill patients given glutamine-supplemented enteral nutrition. *Nutrition* **15**:108-115.
- Jung K and Henke W (1993). The effect of starvation on mitochondrial functions in the rat liver and kidney. *Research in Surgery* **5**:103-105.
- Karakelides H, Asmann YW, Bigelow ML, Short KR, Dhatariya K, Coenen-Schimke J *et al.* (2007). Effect of insulin deprivation on muscle mitochondrial ATP production and gene transcript levels in type 1 diabetic subjects. *Diabetes* **56**:2683-2689.

- Karamanlis A, Chaikomin R, Doran S, Bellon M, Bartholomeusz FD, Wishart JM *et al.* (2007). Effects of protein on glycemic and incretin responses and gastric emptying after oral glucose in healthy subjects. *Am J Clin Nutr* **86**:1364-1368.
- Kim YB, Nikoulina SE, Ciaraldi TP, Henry RR and Kahn BB (1999). Normal insulin-dependent activation of Akt/protein kinase B, with diminished activation of phosphoinositide 3-kinase, in muscle in type 2 diabetes. *J Clin Invest* **104**:733-741.
- Kim YI, Lee FN, Choi WS, Lee S and Youn JH (2006). Insulin regulation of skeletal muscle PDK4 mRNA expression is impaired in acute insulin-resistant states. *Diabetes* **55**:2311-2317.
- Krentz AJ (2002). *Insulin resistance a clinical handbook*. Blackwell Science, Oxford; Malden, MA.
- Krssak M, Falk Petersen K, Dresner A, DiPietro L, Vogel SM, Rothman DL *et al.* (1999). Intramyocellular lipid concentrations are correlated with insulin sensitivity in humans: a ¹H NMR spectroscopy study. *Diabetologia* **42**:113-116.
- Krssak M, Petersen KF, Bergeron R, Price T, Laurent D, Rothman DL *et al.* (2000). Intramuscular glycogen and intramyocellular lipid utilization during prolonged exercise and recovery in man: a ¹³C and ¹H nuclear magnetic resonance spectroscopy study. *J Clin Endocrinol Metab* **85**:748-754.

- Kruszynska YT, Worrall DS, Ofrecio J, Frias JP, Macaraeg G and Olefsky JM (2002). Fatty acid-induced insulin resistance: decreased muscle PI3K activation but unchanged Akt phosphorylation. *J Clin Endocrinol Metab* **87**:226-234.
- Langouche L, Vanhorebeek I, Vlasselaers D, Vander Perre S, Wouters PJ, Skogstrand K *et al.* (2005). Intensive insulin therapy protects the endothelium of critically ill patients. *J Clin Invest* **115**:2277-2286.
- Lassen K, Soop M, Nygren J, Cox PB, Hendry PO, Spies C *et al.* (2009). Consensus review of optimal perioperative care in colorectal surgery: Enhanced Recovery After Surgery (ERAS) Group recommendations. *Arch Surg* **144**:961-969.
- Lebovitz HE (2002). *Clinician's manual on insulin resistance*. Science Press, London.
- Leclercq IA, Da Silva Morais A, Schroyen B, Van Hul N and Geerts A (2007). Insulin resistance in hepatocytes and sinusoidal liver cells: mechanisms and consequences. *J Hepatol* **47**:142-156.
- Lee FN, Zhang L, Zheng D, Choi WS and Youn JH (2004). Insulin suppresses PDK-4 expression in skeletal muscle independently of plasma FFA. *Am J Physiol Endocrinol Metab* **287**:E69-74.
- Leverton E (2009). *In Vivo Metabolic Studies using 13C Magnetic Resonance Spectroscopy*. PhD Thesis, The University of Nottingham.
- Little RA, Henderson A, Frayn KN, Galasko CS and White RH (1987). The disposal of intravenous glucose studied using glucose and insulin clamp

techniques in sepsis and trauma in man. *Acta Anaesthesiol Belg* **38**:275-279.

Ljungqvist O (2004). Preoperative carbohydrates to prepare metabolism for surgery. *Acta Anaesthesiol Belg* **55 Suppl**:61-63.

Ljungqvist O, Boija PO, Esahili H, Larsson M and Ware J (1990). Food deprivation alters liver glycogen metabolism and endocrine responses to hemorrhage. *Am J Physiol* **259**:E692-698.

Ljungqvist O, Efendic S, Eneroth P, Hamberger B, Nylander G and Ware J (1986). Nutritional status and endocrine response to hemorrhage. *Can J Physiol Pharmacol* **64**:1185-1188.

Ljungqvist O, Jansson E and Ware J (1987). Effect of food deprivation on survival after hemorrhage in the rat. *Circ Shock* **22**:251-260.

Ljungqvist O, Nygren J and Thorell A (2002). Modulation of post-operative insulin resistance by pre-operative carbohydrate loading. *Proc Nutr Soc* **61**:329-336.

Ljungqvist O and Soreide E (2003). Preoperative fasting. *Br J Surg* **90**:400-406.

Ljungqvist O, Thorell A, Gutniak M, Haggmark T and Efendic S (1994). Glucose infusion instead of preoperative fasting reduces postoperative insulin resistance. *J Am Coll Surg* **178**:329-336.

Lobo DN, Bostock KA, Bush D, Macdonald IA, Perkins AC, Neal KR *et al.* (2002). Reproducibility and normal ranges for gastric emptying in normal volunteers using a test meal designed for post-operative patients. *Nucl Med Commun* **23**:97-101.

- Lobo DN, Hendry PO, Rodrigues G, Marciani L, Totman JJ, Wright JW *et al.* (2009). Gastric emptying of three liquid oral preoperative metabolic preconditioning regimens measured by magnetic resonance imaging in healthy adult volunteers: A randomised double-blind, crossover study. *Clin Nutr* **28**:636-641.
- Madapallimattam AG, Law L and Jeejeebhoy KN (2002). Effect of hypoenergetic feeding on muscle oxidative phosphorylation and mitochondrial complex I-IV activities in rats. *Am J Clin Nutr* **76**:1031-1039.
- Maltby JR (2006). Fasting from midnight--the history behind the dogma. *Best Pract Res Clin Anaesthesiol* **20**:363-378.
- Mansell PI and Macdonald IA (1990). The effect of starvation on insulin-induced glucose disposal and thermogenesis in humans. *Metabolism* **39**:502-510.
- Marciani L, Gowland PA, Spiller RC, Manoj P, Moore RJ, Young P *et al.* (2000). Gastric response to increased meal viscosity assessed by echo-planar magnetic resonance imaging in humans. *J Nutr* **130**:122-127.
- Marciani L, Wickham MS, Bush D, Faulks R, Wright J, Fillery-Travis AJ *et al.* (2006). Magnetic resonance imaging of the behaviour of oil-in-water emulsions in the gastric lumen of man. *Br J Nutr* **95**:331-339.
- Martin MA, Molina JA, Jimenez-Jimenez FJ, Benito-Leon J, Orti-Pareja M, Campos Y *et al.* (1996). Respiratory-chain enzyme activities in isolated mitochondria of lymphocytes from untreated Parkinson's disease patients. Grupo-Centro de Trastornos del Movimiento. *Neurology* **46**:1343-1346.

- Mathur S, Plank LD, McCall JL, Shapkov P, McIlroy K, Gillanders LK *et al.* (2010). Randomized controlled trial of preoperative oral carbohydrate treatment in major abdominal surgery. *Br J Surg* **97**:485-494.
- Matthews DR, Hosker JP, Rudenski AS, Naylor BA, Treacher DF and Turner RC (1985). Homeostasis model assessment: insulin resistance and beta-cell function from fasting plasma glucose and insulin concentrations in man. *Diabetologia* **28**:412-419.
- McGarry JD (2002). Banting lecture 2001: dysregulation of fatty acid metabolism in the etiology of type 2 diabetes. *Diabetes* **51**:7-18.
- Melis GC, van Leeuwen PA, von Blomberg-van der Flier BM, Goedhart-Hiddinga AC, Uitdehaag BM, Strack van Schijndel RJ *et al.* (2006). A carbohydrate-rich beverage prior to surgery prevents surgery-induced immunodepression: a randomized, controlled, clinical trial. *JPEN J Parenter Enteral Nutr* **30**:21-26.
- Miro O, Barrientos A, Alonso JR, Casademont J, Jarreta D, Urbano-Marquez A *et al.* (1999). Effects of general anaesthetic procedures on mitochondrial function of human skeletal muscle. *Eur J Clin Pharmacol* **55**:35-41.
- Moore FD (1959). *Metabolic Care of the Surgical Patient*. W.B. Saunders Company, Philadelphia and London.
- Morino K, Petersen KF and Shulman GI (2006). Molecular mechanisms of insulin resistance in humans and their potential links with mitochondrial dysfunction. *Diabetes* **55 Suppl 2**:S9-S15.

- Morris PG, McIntyre DJ, Coxon R, Bachelard HS, Moriarty KT, Greenhaff PL *et al.* (1994). Nuclear magnetic resonance spectroscopy as a tool to study carbohydrate metabolism. *Proc Nutr Soc* **53**:335-343.
- Muravchick S and Levy RJ (2006). Clinical implications of mitochondrial dysfunction. *Anesthesiology* **105**:819-837.
- Nakamura T and Sakamoto K (2008). Forkhead transcription factor FOXO subfamily is essential for reactive oxygen species-induced apoptosis. *Mol Cell Endocrinol* **281**:47-55.
- Nath R, Kumar D, Li T and Singal PK (2000). Metallothioneins, oxidative stress and the cardiovascular system. *Toxicology* **155**:17-26.
- Nelson DL, Lehninger AL and Cox MM (2008). *Lehninger Principles Of Biochemistry*. W.H. Freeman, New York.
- Nettelbladt CG, Katouli M, Volpe A, Bark T, Muratov V, Svenberg T *et al.* (1997). Starvation increases the number of coliform bacteria in the caecum and induces bacterial adherence to caecal epithelium in rats. *Eur J Surg* **163**:135-142.
- Newman WP and Brodows RG (1983). Insulin action during acute starvation: evidence for selective insulin resistance in normal man. *Metabolism* **32**:590-596.
- Niki E (2008). Lipid peroxidation products as oxidative stress biomarkers. *Biofactors* **34**:171-180.
- Nordenstrom J, Sonnenfeld T and Arner P (1989). Characterization of insulin resistance after surgery. *Surgery* **105**:28-35.

- Nygren J (2006). The metabolic effects of fasting and surgery. *Best Pract Res Clin Anaesthesiol* **20**:429-438.
- Nygren J, Soop M, Thorell A, Efendic S, Nair KS and Ljungqvist O (1998a). Preoperative oral carbohydrate administration reduces postoperative insulin resistance. *Clin Nutr* **17**:65-71.
- Nygren J, Soop M, Thorell A, Sree Nair K and Ljungqvist O (1999). Preoperative oral carbohydrates and postoperative insulin resistance. *Clin Nutr* **18**:117-120.
- Nygren J, Thorell A, Brismar K, Karpe F and Ljungqvist O (1997a). Short-term hypocaloric nutrition but not bed rest decrease insulin sensitivity and IGF-I bioavailability in healthy subjects: the importance of glucagon. *Nutrition* **13**:945-951.
- Nygren J, Thorell A, Efendic S, Nair KS and Ljungqvist O (1997b). Site of insulin resistance after surgery: the contribution of hypocaloric nutrition and bed rest. *Clin Sci (Lond)* **93**:137-146.
- Nygren J, Thorell A, Jacobsson H, Larsson S, Schnell PO, Hysten L *et al.* (1995). Preoperative gastric emptying. Effects of anxiety and oral carbohydrate administration. *Ann Surg* **222**:728-734.
- Nygren J, Thorell A and Ljungqvist O (2001). Preoperative oral carbohydrate nutrition: an update. *Curr Opin Clin Nutr Metab Care* **4**:255-259.
- Nygren JO, Thorell A, Soop M, Efendic S, Brismar K, Karpe F *et al.* (1998b). Perioperative insulin and glucose infusion maintains normal insulin sensitivity after surgery. *Am J Physiol* **275**:E140-148.

- Oberhelman HA, Jr., Woodward ER, Zubiran JM and Dragstedt LR (1952). Physiology of the gastric antrum. *Am J Physiol* **169**:738-748.
- Orzechowski A (2003). Justification for antioxidant preconditioning (or how to protect insulin-mediated actions under oxidative stress). *J Biosci* **28**:39-49.
- Petersen KF, Befroy D, Dufour S, Dziura J, Ariyan C, Rothman DL *et al.* (2003). Mitochondrial dysfunction in the elderly: possible role in insulin resistance. *Science* **300**:1140-1142.
- Petersen KF, Dufour S, Befroy D, Garcia R and Shulman GI (2004). Impaired mitochondrial activity in the insulin-resistant offspring of patients with type 2 diabetes. *N Engl J Med* **350**:664-671.
- Petersen KF and Shulman GI (2006). Etiology of insulin resistance. *Am J Med* **119**:S10-16.
- Phillips DI, Caddy S, Ilic V, Fielding BA, Frayn KN, Borthwick AC *et al.* (1996). Intramuscular triglyceride and muscle insulin sensitivity: evidence for a relationship in nondiabetic subjects. *Metabolism* **45**:947-950.
- Pilegaard H, Saltin B and Neufer PD (2003). Effect of short-term fasting and refeeding on transcriptional regulation of metabolic genes in human skeletal muscle. *Diabetes* **52**:657-662.
- Reimann F, Williams L, da Silva Xavier G, Rutter GA and Gribble FM (2004). Glutamine potently stimulates glucagon-like peptide-1 secretion from GLUTag cells. *Diabetologia* **47**:1592-1601.

- Ritz P and Berrut G (2005). Mitochondrial function, energy expenditure, aging and insulin resistance. *Diabetes Metab* **31 Spec No 2**:5S67-65S73.
- Roden M, Petersen KF and Shulman GI (2001). Nuclear magnetic resonance studies of hepatic glucose metabolism in humans. *Recent Prog Horm Res* **56**:219-237.
- Roth E (2001). Oral glutamine: does it make sense? *Nutrition* **17**:52-53.
- Rothman DL, Magnusson I, Katz LD, Shulman RG and Shulman GI (1991). Quantitation of hepatic glycogenolysis and gluconeogenesis in fasting humans with ¹³C NMR. *Science* **254**:573-576.
- Samra JS, Clark ML, Humphreys SM, Macdonald IA and Frayn KN (1996). Regulation of lipid metabolism in adipose tissue during early starvation. *Am J Physiol* **271**:E541-546.
- Schofield WN (1985). Predicting basal metabolic rate, new standards and review of previous work. *Hum Nutr Clin Nutr* **39 Suppl 1**:5-41.
- Senkal M, Zumtobel V, Bauer KH, Marpe B, Wolfram G, Frei A *et al.* (1999). Outcome and cost-effectiveness of perioperative enteral immunonutrition in patients undergoing elective upper gastrointestinal tract surgery: a prospective randomized study. *Arch Surg* **134**:1309-1316.
- Shulman GI (1999). Cellular mechanisms of insulin resistance in humans. *Am J Cardiol* **84**:3J-10J.
- Sidery MB, Macdonald IA and Blackshaw PE (1994). Superior mesenteric artery blood flow and gastric emptying in humans and the differential effects of high fat and high carbohydrate meals. *Gut* **35**:186-190.

- Simpkins C, Lloyd T, Li S and Balderman S (1998). Metallothionein-induced increase in mitochondrial inner membrane permeability. *J Surg Res* **75**:30-34.
- Smith AF (2006). Preoperative fasting in adults, in: *In: Raising the standard. A compendium of audit recipes for continuous quality improvement in anaesthesia*, Royal College of Anaesthetists.
- Snyderman CH, Kachman K, Molseed L, Wagner R, D'Amico F, Bumpous J *et al.* (1999). Reduced postoperative infections with an immune-enhancing nutritional supplement. *Laryngoscope* **109**:915-921.
- Test solutions: Simulated Gastric Fluid. US Pharmacopeia. http://www.pharmacopeia.cn/v29240/usp29nf24s0_ris1s126.html#usp29nf24s0_ris1s237.
- Soop M, Nygren J, Myrenfors P, Thorell A and Ljungqvist O (2001). Preoperative oral carbohydrate treatment attenuates immediate postoperative insulin resistance. *Am J Physiol Endocrinol Metab* **280**:E576-583.
- Soop M, Nygren J, Thorell A, Weidenhielm L, Lundberg M, Hammarqvist F *et al.* (2004). Preoperative oral carbohydrate treatment attenuates endogenous glucose release 3 days after surgery. *Clin Nutr* **23**:733-741.
- Soreide E, Fasting S and Raeder J (1997). New preoperative fasting guidelines in Norway. *Acta Anaesthesiol Scand* **41**:799.
- Sorensen M, Sanz A, Gomez J, Pamplona R, Portero-Otin M, Gredilla R *et al.* (2006). Effects of fasting on oxidative stress in rat liver mitochondria. *Free Radic Res* **40**:339-347.

- Sparks LM, Xie H, Koza RA, Mynatt R, Hulver MW, Bray GA *et al.* (2005). A high-fat diet coordinately downregulates genes required for mitochondrial oxidative phosphorylation in skeletal muscle. *Diabetes* **54**:1926-1933.
- Spriet LL, Tunstall RJ, Watt MJ, Mehan KA, Hargreaves M and Cameron-Smith D (2004). Pyruvate dehydrogenase activation and kinase expression in human skeletal muscle during fasting. *J Appl Physiol* **96**:2082-2087.
- Stump CS, Short KR, Bigelow ML, Schimke JM and Nair KS (2003). Effect of insulin on human skeletal muscle mitochondrial ATP production, protein synthesis, and mRNA transcripts. *Proc Natl Acad Sci U S A* **100**:7996-8001.
- Sugden MC, Bulmer K and Holness MJ (2001). Fuel-sensing mechanisms integrating lipid and carbohydrate utilization. *Biochem Soc Trans* **29**:272-278.
- Sugden MC and Holness MJ (1994). Interactive regulation of the pyruvate dehydrogenase complex and the carnitine palmitoyltransferase system. *FASEB J* **8**:54-61.
- Sugden MC, Howard RM, Munday MR and Holness MJ (1993). Mechanisms involved in the coordinate regulation of strategic enzymes of glucose metabolism. *Adv Enzyme Regul* **33**:71-95.
- Svanfeldt M, Thorell A, Brismar K, Nygren J and Ljungqvist O (2003). Effects of 3 days of "postoperative" low caloric feeding with or without bed rest on insulin sensitivity in healthy subjects. *Clin Nutr* **22**:31-38.
- Svanfeldt M, Thorell A, Hausel J, Soop M, Nygren J and Ljungqvist O (2005). Effect of "preoperative" oral carbohydrate treatment on insulin action--a

randomised cross-over unblinded study in healthy subjects. *Clin Nutr* **24**:815-821.

Svanfeldt M, Thorell A, Hausel J, Soop M, Rooyackers O, Nygren J *et al.* (2007). Randomized clinical trial of the effect of preoperative oral carbohydrate treatment on postoperative whole-body protein and glucose kinetics. *Br J Surg* **94**:1342-1350.

Taylor R, Magnusson I, Rothman DL, Cline GW, Caumo A, Cobelli C *et al.* (1996). Direct assessment of liver glycogen storage by ¹³C nuclear magnetic resonance spectroscopy and regulation of glucose homeostasis after a mixed meal in normal subjects. *J Clin Invest* **97**:126-132.

Tepaske R, Velthuis H, Oudemans-van Straaten HM, Heisterkamp SH, van Deventer SJ, Ince C *et al.* (2001). Effect of preoperative oral immune-enhancing nutritional supplement on patients at high risk of infection after cardiac surgery: a randomised placebo-controlled trial. *Lancet* **358**:696-701.

Thorell A, Alston-Smith J and Ljungqvist O (1996a). The effect of preoperative carbohydrate loading on hormonal changes, hepatic glycogen, and glucoregulatory enzymes during abdominal surgery. *Nutrition* **12**:690-695.

Thorell A, Efendic S, Gutniak M, Haggmark T and Ljungqvist O (1993). Development of postoperative insulin resistance is associated with the magnitude of operation. *Eur J Surg* **159**:593-599.

- Thorell A, Efendic S, Gutniak M, Haggmark T and Ljungqvist O (1994). Insulin resistance after abdominal surgery. *Br J Surg* **81**:59-63.
- Thorell A, Nygren J, Essen P, Gutniak M, Loftenius A, Andersson B *et al.* (1996b). The metabolic response to cholecystectomy: insulin resistance after open compared with laparoscopic operation. *Eur J Surg* **162**:187-191.
- Thorell A, Nygren J, Hirshman MF, Hayashi T, Nair KS, Horton ES *et al.* (1999a). Surgery-induced insulin resistance in human patients: relation to glucose transport and utilization. *Am J Physiol* **276**:E754-761.
- Thorell A, Nygren J and Ljungqvist O (1999b). Insulin resistance: a marker of surgical stress. *Curr Opin Clin Nutr Metab Care* **2**:69-78.
- Tsintzas K, Chokkalingam K, Jewell K, Norton L, Macdonald IA and Constantin-Teodosiu D (2007). Elevated Free Fatty Acids Attenuate the Insulin-Induced Suppression of PDK4 Gene Expression in Human Skeletal Muscle: Potential Role of Intramuscular Long-Chain Acyl-Coenzyme A. *J Clin Endocrinol Metab* **92**:3967-3972.
- Tsintzas K, Jewell K, Kamran M, Laithwaite D, Boonsong T, Littlewood J *et al.* (2006). Differential regulation of metabolic genes in skeletal muscle during starvation and refeeding in humans. *J Physiol* **575**:291-303.
- van den Berghe G, Wouters P, Weekers F, Verwaest C, Bruyninckx F, Schetz M *et al.* (2001). Intensive insulin therapy in the critically ill patients. *N Engl J Med* **345**:1359-1367.

- Van den Berghe G, Wouters PJ, Bouillon R, Weekers F, Verwaest C, Schetz M *et al.* (2003). Outcome benefit of intensive insulin therapy in the critically ill: Insulin dose versus glycemic control. *Crit Care Med* **31**:359-366.
- van Eijk HM, Rooyackers DR and Deutz NE (1993). Rapid routine determination of amino acids in plasma by high-performance liquid chromatography with a 2-3 microns Spherisorb ODS II column. *J Chromatogr* **620**:143-148.
- van Hoorn DE, Boelens PG, van Middelaar-Voskuilen MC, Nijveldt RJ, Prins H, Bouritius H *et al.* (2005a). Preoperative feeding preserves heart function and decreases oxidative injury in rats. *Nutrition* **21**:859-866.
- van Hoorn EC, van Middelaar-Voskuilen MC, van Limpt CJ, Lamb KJ, Bouritius H, Vriesema AJ *et al.* (2005b). Preoperative supplementation with a carbohydrate mixture decreases organ dysfunction-associated risk factors. *Clin Nutr* **24**:114-123.
- Vanhamme L, van den Boogaart A and Van Huffel S (1997). Improved method for accurate and efficient quantification of MRS data with use of prior knowledge. *J Magn Reson* **129**:35-43.
- Vanhorebeek I, De Vos R, Mesotten D, Wouters PJ, De Wolf-Peeters C and Van den Berghe G (2005). Protection of hepatocyte mitochondrial ultrastructure and function by strict blood glucose control with insulin in critically ill patients. *Lancet* **365**:53-59.
- Vanhorebeek I, Langouche L and Van den Berghe G (2007). Tight blood glucose control: what is the evidence? *Crit Care Med* **35**:S496-502.

- Vendemiale G, Grattagliano I, Caraceni P, Caraccio G, Domenicali M, Dall'Agata M *et al.* (2001). Mitochondrial oxidative injury and energy metabolism alteration in rat fatty liver: effect of the nutritional status. *Hepatology* **33**:808-815.
- Vist GE and Maughan RJ (1995). The effect of osmolality and carbohydrate content on the rate of gastric emptying of liquids in man. *J Physiol* **486** (Pt 2):523-531.
- Warner MA, Warner ME and Weber JG (1993). Clinical significance of pulmonary aspiration during the perioperative period. *Anesthesiology* **78**:56-62.
- Webber J and Macdonald IA (1994). The cardiovascular, metabolic and hormonal changes accompanying acute starvation in men and women. *Br J Nutr* **71**:437-447.
- Webber J, Taylor J, Greathead H, Dawson J, Buttery PJ and Macdonald IA (1994). Effects of fasting on fatty acid kinetics and on the cardiovascular, thermogenic and metabolic responses to the glucose clamp. *Clin Sci (Lond)* **87**:697-706.
- Weekers F, Giulietti AP, Michalaki M, Coopmans W, Van Herck E, Mathieu C *et al.* (2003). Metabolic, endocrine, and immune effects of stress hyperglycemia in a rabbit model of prolonged critical illness. *Endocrinology* **144**:5329-5338.
- Welch IM, Bruce C, Hill SE and Read NW (1987). Duodenal and ileal lipid suppresses postprandial blood glucose and insulin responses in man:

possible implications for the dietary management of diabetes mellitus. *Clin Sci (Lond)* **72**:209-216.

Wibom R, Hagenfeldt L and von Döbeln U (2002). Measurement of ATP production and respiratory chain enzyme activities in mitochondria isolated from small muscle biopsy samples. *Anal Biochem* **311**:139-151.

Wibom R and Hultman E (1990). ATP production rate in mitochondria isolated from microsamples of human muscle. *Am J Physiol* **259**:E204-209.

Wolfe RR, Durkot MJ, Allsop JR and Burke JF (1979). Glucose metabolism in severely burned patients. *Metabolism* **28**:1031-1039.

Wu P, Inskeep K, Bowker-Kinley MM, Popov KM and Harris RA (1999). Mechanism responsible for inactivation of skeletal muscle pyruvate dehydrogenase complex in starvation and diabetes. *Diabetes* **48**:1593-1599.

Yuill KA, Richardson RA, Davidson HI, Garden OJ and Parks RW (2005). The administration of an oral carbohydrate-containing fluid prior to major elective upper-gastrointestinal surgery preserves skeletal muscle mass postoperatively--a randomised clinical trial. *Clin Nutr* **24**:32-37.

Appendix A

Analysis and composition of standard meal ingested by volunteers in the study outlined in Chapter 4. Abbreviations: **CHO** – carbohydrate, **BMR** – basal metabolic rate (calculated from the Schofield equation (Schofield, 1985): $RMR \text{ (age 18-30)} = (0.063 \times \text{weight}) + 2.896$. $RMR \text{ (age 30-60)} = (0.048 \times \text{weight}) + 3.653$), **RMR** – resting metabolic rate, **ER_{FD}** – Daily energy requirements calculated from 3-day food diary completed by the study participants the week prior to commencing the study, **ER_{CALC}** - Daily energy requirement calculated from RMR assuming light level of activity (1.5 x BMR).

Volunteer Number												
	1	2	3	4	5	6	7	8	9	10	11	12
Age (years)	29	21	21	19	19	19	20	31	20	29	23	24
Baseline weight (kg)	63.3	61.1	72.6	83.7	83.5	63.7	70.8	68.3	72.5	80.6	74.3	93.8
ER_{FD}, kJ/day	7969	9949	9365	7147	10791	7940	11417	8145	3518	13192	8192	9929
BMR, kJ/day	6883.9	6745.3	7469.8	8169.1	8156.5	6909.1	7356.4	6931.4	7463.5	7973.8	7576.9	8805.4
ER_{CALC}, kJ/day	10326	10118	11205	12254	12235	10364	11035	10397	11195	11961	11365	13208
Daily ER_{FD}/ER_{CALC}, %	78	98	84	58	89	77	103	79	78	110	76	76

Composition of the standard meal												
Porridge (g)	120	160	125	120	160	120	160	120	120	180	100	160
Sugar (g)	30	48	45	25	60	35	65	40	40	82	36	50
Cream (g)	22.5	45	30	15	52.5	22.5	54	24	26	56	26	45
Whey protein (g)	15	20	19	10	25	15	27	15	17	30	17	20
Milk (ml)	200	225	250	250	200	215	250	215	225	300	250	250
Slices of bread	2	2	2	2	2	2	2	2	2	2	2	2
Jam (g)	30	48	30	18	30	18	30	16.5	27	30	30	26
Butter	2 x thinly spread	2 x thinly spread	2 x thinly spread	2 x thinly spread	1 x thinly spread	2 x thinly spread	2 x thinly spread	2 x thinly spread	2 x thinly spread	2x thickly spread	2 x thinly spread	2 x thinly spread
Energy kJ (kCal)	3202 759	3956 939	3777 896	2858 678	4340 1030	3176 754	4548 1088	3280 778	3494 829	5277 1255	3470 823	3996 948
Total CHO (g)	102.05	125.75	102.68	91.26	137.30	99.73	144.93	103.97	111.72	166.78	109.14	126.44
Total fat (g)	29.48	36.67	34.42	26.29	40.28	29.73	41.94	30.54	31.92	50.01	32.13	37.09
Total protein (g)	28.23	34.60	33.83	25.11	38.51	28.67	42.09	28.69	30.98	46.92	31.57	35.43

