

Towle, Josie A. (1986) Increasing the precision of measurement of postures in free space. PhD thesis, University of Nottingham.

**Access from the University of Nottingham repository:**

<http://eprints.nottingham.ac.uk/11193/1/371265.pdf>

**Copyright and reuse:**

The Nottingham ePrints service makes this work by researchers of the University of Nottingham available open access under the following conditions.

- Copyright and all moral rights to the version of the paper presented here belong to the individual author(s) and/or other copyright owners.
- To the extent reasonable and practicable the material made available in Nottingham ePrints has been checked for eligibility before being made available.
- Copies of full items can be used for personal research or study, educational, or not-for-profit purposes without prior permission or charge provided that the authors, title and full bibliographic details are credited, a hyperlink and/or URL is given for the original metadata page and the content is not changed in any way.
- Quotations or similar reproductions must be sufficiently acknowledged.

Please see our full end user licence at:

[http://eprints.nottingham.ac.uk/end\\_user\\_agreement.pdf](http://eprints.nottingham.ac.uk/end_user_agreement.pdf)

**A note on versions:**

The version presented here may differ from the published version or from the version of record. If you wish to cite this item you are advised to consult the publisher's version. Please see the repository url above for details on accessing the published version and note that access may require a subscription.

For more information, please contact [eprints@nottingham.ac.uk](mailto:eprints@nottingham.ac.uk)

**BEST COPY**

**AVAILABLE**

Variable print quality

INCREASING THE PRECISION OF MEASUREMENT OF

POSTURES IN FREE SPACE

by

Josie A. Towle, B.Sc.

Thesis submitted to the University of Nottingham for  
the degree of Doctor of Philosophy, May, 1986.

## SUMMARY

We have at our disposal a piece of equipment which can accurately define body positions in free space. The question to be answered is, can we, by applying this technique in the field of clinical gait analysis, (paying particular attention to the dynamic characteristics of the knee joint), further our knowledge of the kinematic behaviour of in-vivo human joint endoprotheses and diseased natural joints.

Although I am in no way attempting to derogate the system described, it will be suggested that our justification for use of such a technique in this particular clinical application is questionable. Proposals for other clinical and some non-clinical applications will be made in the light of pilot studies conducted in our laboratory and suggestions made by fellow workers.

## TABLE OF CONTENTS

Abstract	1
Summary	2
Acknowledgements	3
Chapter I	
Introduction	4
Chapter II	
Literature Review	5
Introduction	5
Knee Joint Force Estimation	6
Knee Joint Rotations	7
Chapter III	
Formulation of the Problem	8
Chapter IV	
Equipment	9
Introduction	9
CODA-3 Scanner Unit	10
Shelton Signet Microprocessor	11
Interfacing	12
The Laboratory Computer	13
Force Platform	14
Software	15

## Chapter V

### Evaluation of Methods

#### Introduction

(1.0) Landmark Fixation Techniques

(2.0) Landmark Location and Movement

(3.0) CODA-3 Output Reliability

(3.1) Static Tests

(3.2) Dynamic Tests

(3.3) Data Capture

## Chapter VI

### Experiments

(1.0) Introduction

(2.0) Pilot Study

(3.0) Platina Method

(4.0) Software

(5.0) Reproducibility

(6.0) Abnormal Gait Patterns

(7.0) Acceleration Profiles

(8.0) Supplementary Experiments

## Chapter VII

### Discussion

## Chapter VIII

### Conclusions

## ACKNOWLEDGEMENTS

Amonast the many individuals who have helped me over the past three years I would like to say a specials thanks to the following:-

Professor Waugh who introduced me to the world of Orthopaedics,

Professor Corlett, my supervisor, for his help and advice throughout the project,

Staff in the Departments of--Orthopaedic and Accident Surgery and Production Engineering, in particular Moira Tracy and Nick Milner,

Dave Mitchelson the father of CODA-3 for his help during the project,

And most importantly, Jean, Geoff and Alan.

The author acknowledges the financial support of the Arthritis and Rheumatism Council over the last three years.

## ABSTRACT

The project set out to use a very precise three dimensional tracking system to identify changes in joint condition for use in clinical assessment. Untried and untested the CODA-3 was brought into the department and put through a six month period of validation in order to evaluate it's capabilities. These are described in detail in the text. Once satisfied that the equipment was capable of measuring minute rapidly changing position of it's prismatic markers, pilot studies were devised to assess it's ability to reproduce the results from well recognised gait analysis techniques. It gave promising results.

The next task was to determine which set of parameters we could derive using CODA-3 that would be of use in describing the kinematics of the diseased and/or prosthetic knee for use as a tool in clinical assessment.

Using FORTRAN, subroutines were written and run on a DEC LSI-11 computer, to collect, store and analyse the x, y and z coordinates of the eight CODA landmarks. It was hoped that by appropriate siting of the markers the velocities and accelerations of the segments comprising a joint could be monitored throughout the gait cycle. The resultant patterns of these parameters



were plotted out, and the actual data values stored.

It was hypothesised that weaknesses in a joint, whether or not detectable by clinical examination, would, at points in the gait cycle of maximum joint loading be seen as ectopics in the smooth waveform of the acceleration and velocity profiles expected from the normal knee.

The results the author presents would suggest that if the limitations of this particular model could be overcome (as it is reported they will be), then the technique has the capability of highlighting abnormalities in a joint. The author is doubtful however that these same weaknesses could not be detected by the clinician. The system may well have other applications related to this area of work and these are discussed.

## INTRODUCTION.

### Human Locomotion.

Homo sapiens is essentially a mobile organism provided with a musculoskeletal system allowing him to carry out a variety of activities. His various habitats require him to possess combinations of speed, endurance and accuracy of movement ideally at low energy cost. These movements range from gross body displacements to small movements of individual elements. The control mechanism for all these movements consists of a complicated network of nervous tissue which maintains the balance of activity between the muscles which produce the desired (though not necessarily voluntary) movement. Our particular interest is that of ambulation, and for the most part this thesis will use the term "movement" synonymously with gait.

We can tell both by sound and sight if a person's usually well co-ordinated sequence of movements comprising a "normal gait" has broken down. It is only when the system "breaks down" that the individual realises how automatic the act of walking is. In Grieve's 1969 paper on the assessment of gait he states "Walking like many other repetitive activities.....is

thoroughly familiar to us, yet how many of us could state what movements take place in anatomical terms or in their proper sequence ?" Any loss of mobility through accident or disease greatly affects the individuals approach to life both physically and psychologically, not least of all because of his loss of independence. These disabilities involving the musculoskeletal system by nature of their pathology, invariably result in the patient experiencing some degree of discomfort. The desire to eradicate pain (the extreme of discomfort), is the primary reason for consultation of medical help and avoidance of tasks which might irritate the condition (Wall 1979).

### Joint Conditions

This study is centred around those individuals whose main pathology lies within the knee joint and associated structures. However the interplay between all components of the skeletal system has to be borne in mind and on all possible occasions an holistic approach to the problem should be made.

Joint degeneration as seen in osteo and rheumatoid arthritis can be due either to underlying metabolic abnormalities or primarily of mechanical cause, ie. an inability of the tissues to resist stresses applied to the joint. If these stresses are high enough Ligament

rupture may occur as can long bone fracture. The wearing away of articular cartilage brought about by these mechanical forces, can be preceded by factors such as chemical, enzymic or metabolic influences which lower its yield strength. Once the tensile strength of the cartilage is exceeded "wear" results. Persistent stresses will result in failure to heal, and these are the cases which present themselves to the clinician.

Not only in the natural knee joint but also in the prosthetic knee, mechanical factors can bring about joint damage. Loosening of a prosthesis can be as a result of repetitive impacting, malpositioning of the prosthesis or prosthetic obliquity, where the prosthesis is implanted at an angle to the horizontal.

Tables 1 and 2 show the number of individuals who sought medical advice for a variety of musculoskeletal disorders. Table 3 shows for that same sample, the number of specific operations carried out. Here arthroplasty relates to all joint replacements and not only to knee joint replacements.

When conservative treatment has failed to arrest or delay the progression of an active (inflammatory) stage of a rheumatoid or osteo-arthritic attack, then, if it is felt appropriate an arthroplast may be implanted as a means of alleviating pain and restoring

CONSULTATIONS PER THOUSAND POPULATION:

SEX, AGE, DIAGNOSED CONDITION.

		ALL	0-	5-	15-	25-	45-	65-	75+
		AGES	4	14	24	44	64	74	
RA and allied conditions.	M	10.0	0.2	0.1	0.7	6.0	22.0	30.9	25.0
	F	23.1	0.3	0.9	2.5	11.9	39.4	83.3	49.8
	P	16.8	0.3	0.5	1.7	9.0	31.0	61.2	41.8
OA and allied conditions.	M	28.4	0.1	0.1	1.3	9.8	58.3	108.7	129.2
	F	55.8	-	0.3	1.1	10.4	78.7	188.7	292.3
	P	42.7	0.1	0.2	1.2	10.1	68.8	155.0	240.0

RA Rheumatoid Arthritic

OA Osteoarthritic

M Male

F Female

P Population

TABLE 1

CONSULTATIONS PER THOUSAND POPULATION:

SEX, AGE, DIAGNOSED CONDITION.

		ALL	0-	5-	15-	25-	45-	65-	75+
		AGES	4	14	24	44	64	74	
Torn meniscus of the knee.	M	3.9	-	0.7	6.7	7.5	3.2	0.5	0.3
	F	1.1	-	0.7	2.2	1.1	1.4	1.0	0.3
	P	2.5	-	0.7	4.4	4.3	2.3	0.8	0.3
Other forms of internal DOK.	M	4.3	1.0	1.5	6.3	7.1	4.7	0.7	1.2
	F	2.1	0.4	2.0	3.1	1.9	2.8	1.2	0.8
	P	3.2	0.7	1.8	4.6	4.4	3.8	1.0	1.0

DOK Derangement of the knee

M Male

F Female

P Population

TABLE 2

ESTIMATED NUMBER OF OPERATIONS PER 100,000

SEX, AGE, NATURE OF OPERATION.

	ALL	0-	5-	15-	45-	65-	75+
	AGES	4	14	44	64	74	
Arthroplasty M	41.1	2.0	2.0	7.9	71.5	170.2	192.9
(All types). F	106.1	1.4	2.7	14.9	128.5	329.5	505.4
Excision of M semi-lunar cartilage	46.7	-	4.8	92.3	28.6	3.0	-
F	9.3	0.7	2.1	17.2	8.0	3.1	1.1

TABLE 3

as much function as possible to a diseased joint. The failure rate for the total knee joint replacement operation is shown in tables 4 and 5 from a total of 365 operations carried out between 1972 and 1980 at Harlow Wood Orthopaedic Hospital. (Tew and Waugh 1982). The comparatively short life expectancy of the prosthetic knee may be attributed to the higher mechanical stresses involved compared with some of the more congruent joints such as the hip (Johnson 1982).

If failure in the form of a revision operation becomes necessary the critical mechanical factors seem to be wear and loosening, which may or may not be associated with malalignment of the prosthesis. If those patients at risk can be recognised by their pathomechanics then this will be of value in their management and in making a prognosis. Therefore if we have a method of evaluating the degree of prosthesis damage without waiting for failure i.e. in-vivo, their treatment can be organised such that they undergo minimal amounts of surgery and can maintain an independent pain-free lifestyle.

Likewise there is a group of patients who exhibit chronic instability of the knee due to ligamentous injury or meniscal damage. These two conditions have been seen to be followed by the development of osteoarthritis of the knee in later life (Fetto and



ESTIMATED ANNUAL FAILURE RATE OF KNEE REPLACEMENTS

WHERE SUCCESS IS DEFINED AS THE PROSTHESIS

REMAINING IN SITU.

Years Since Operation.      Annual Failure Rate  
(per cent).

0 - 1	0.9
>1 - 2	2.3
>2 - 3	6.5
>3 - 4	6.3
>4 - 5	8.6
>5 - 6	7.0
>6 - 7	13.3
>7 - 8	18.2
>8 - 9	66.7

Table 4

Reproduced from Tew and Waugh (1982).

ESTIMATED ANNUAL FAILURE RATE OF KNEE REPLACEMENTS  
WHERE SUCCESS IS DEFINED AS THE PROSTHESIS REMAINING  
IN SITU WITHOUT CAUSING SEVERE PAIN.

Years Since Operation.      Annual Failure Rate.  
(per cent).

0 - 1	2.3
>1 - 2	4.0
>2 - 3	11.7
>3 - 4	10.5
>4 - 5	14.8
>5 - 6	26.6
>6 - 7	28.6
>7 - 8	18.2
>8 - 9	66.7

Table 5

Reproduced from Tew and Waugh (1982).

Marshall 1981, Fairbank 1948). Recognition of those patients likely to develop subsequent joint disease will obviously aid in planning treatment regimes whether in the form of drug therapy, physiotherapy or surgery. Hence, as with the knee-replacement patients, a knowledge of the pathomechanics of the knee involved may help to highlight those factors which are related to subsequent joint degeneration.

### Biomechanics

The common element in these two groups of patients seems to be the need to quantify movement and loading leading to an improvement in our knowledge of the mechanics of the joint. This would ideally be done in-vivo, so excluding the possibility of using techniques employed in tribology, eg. wear and creep analysis. (For details of this work see Seedhom(1973)). The area of study which aims to describe these human movements is that of kinematics. The description is carried out independently of the forces that cause the movement. The field of kinetics on the other hand, attempts to describe the internal and external forces which produce those movements.

### Kinematics.

If we wish to describe the movement of one body

segment relative to another we use terms such as flexion, extension, proximal and distal borrowed from the anatomist's vocabulary, these terms completely describe a movement. They do not however locate a body in free space, for this we need to establish an absolute spatial reference system. The convention in human movement studies uses the XYZ cartesian co-ordinate system:-

X direction (anterior-posterior) is along the line of progression,

Y the vertical direction,

Z the sideways (mediolateral) direction.

See figure 1.

Likewise a convention for zero reference and positive direction have been set-up and similarly for velocity and acceleration (both angular and linear). The kinematics of a body segment can hence be described by a vast number of variables, far too many for manageable purposes, so to make an analysis more practical assumptions about planes of movement, symmetry of movement and grouping of several segments into one, are carried out. For a comprehensive description of methods of data conversion and processing see Winter (1979). Some of the various techniques available for measurement of these variables

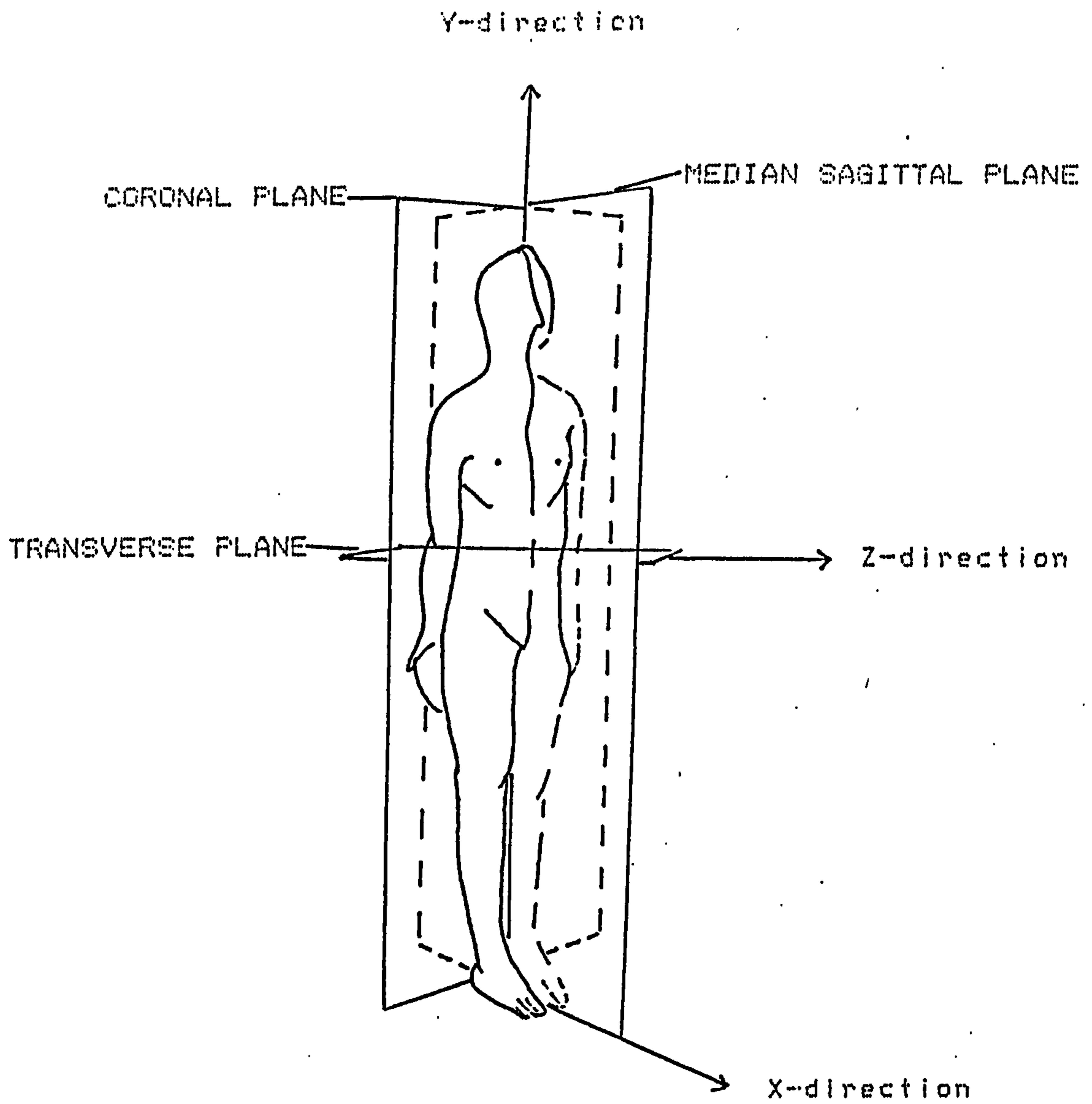

CONVENTIONAL CO-ORDINATE SYSTEM USED IN HUMAN  
MOVEMENT STUDIES.

Figure 1

are discussed in the literature review.

## Kinetics

There are very few acceptable techniques which allow the direct measurement of joint forces, hence kinetics tends to use an indirect method of calculation using kinematic, anthropometric and external force data. The essential for this type of calculation is a good model on which to work, and this is often in the form of a link segment model. Breaking this model down into its component parts yields a free body diagram of each segment. Taken into account are the gravitational, external and muscular forces along with the reaction force between segments. Again examples of this technique of free body diagrams and their associated calculations will be discussed in the literature review.

In clinical applications where the problems discussed earlier are the main areas of concern, the clinician presently relies upon clinical laxity tests which give him some measure of the degree of joint hypermobility, hence laxity.

## Laxity Tests

Translational movements of the tibia on the femur

can be detected by laxity of movement under stress. Anterior-posterior and rotational instability can be detected and conclusions drawn about ligamentous injury. The Lateral Pivot shift test and the anterior drawer sign, when positive, suggest anterior subluxation of the tibia on the femur indicative of anterior cruciate ligament pathology. The drawer sign is deemed positive when both anteriorlateral and anteriomedial rotatory instability are evident. (Combined ALRI and AMRI.) A positive drawer sign can also be elicited when posteriolateral rotatory instability is present. In this situation the posterior cruciate ligaments have impaired function, allowing the tibia to sublux posteriorly on the femur. There are many permutations on the above mentioned tests revealing combinations of ligamentous injuries of the knee

There appears to be a need for a system or systems that allow the analysis of stresses within the human joints, both natural and prosthetic. In order to quantify these loads a knowledge of the movements of the lower limb segments is required. Ideally the system would interfere minimally with gait, be quick to set-up and calibrate, give on-line data analysis and the facility for hard copy results. Primarily it should yield results which can be used to identify any changes in the condition of the joint.

As will be seen from the literature review there are on the market several biomechanics force platforms (Kistler, AMTI), used in the measurement of joint loading. However the techniques used for precisely locating limb segments in free space fall short of the ideal for one reason or another. Our aim in this project is to evaluate the use of one such technique of 3-dimensional orientation of body parts.



LITERATURE REVIEW.

## LITERATURE REVIEW

Knee Joint Force Estimation, Knee Joint Rotation,  
Indices of Function.

## INTRODUCTION

Phases of the Gait Cycle.

Many workers including Peizer and Wright (1971), Murray (1967) and Inman et al (1981) choose to divide the gait cycle into two parts, namely stance and swing phase (See figure 2). These, as the names would suggest account for the time spent by one or the other leg with the foot planted onto the ground, stance phase, or freely swinging after removal of that foot from the ground, swing phase.

There are six key events within the stance phase beginning with heel contact, followed by foot flat (the sole making contact with the ground), then mid-stance (as the body is swung over the supporting leg). After this point the foot is gradually brought off the ground, firstly in what is called the heel-off phase, then in push-off as the calf muscles increase in activity and finally in toe-off where the entire foot leaves the ground.

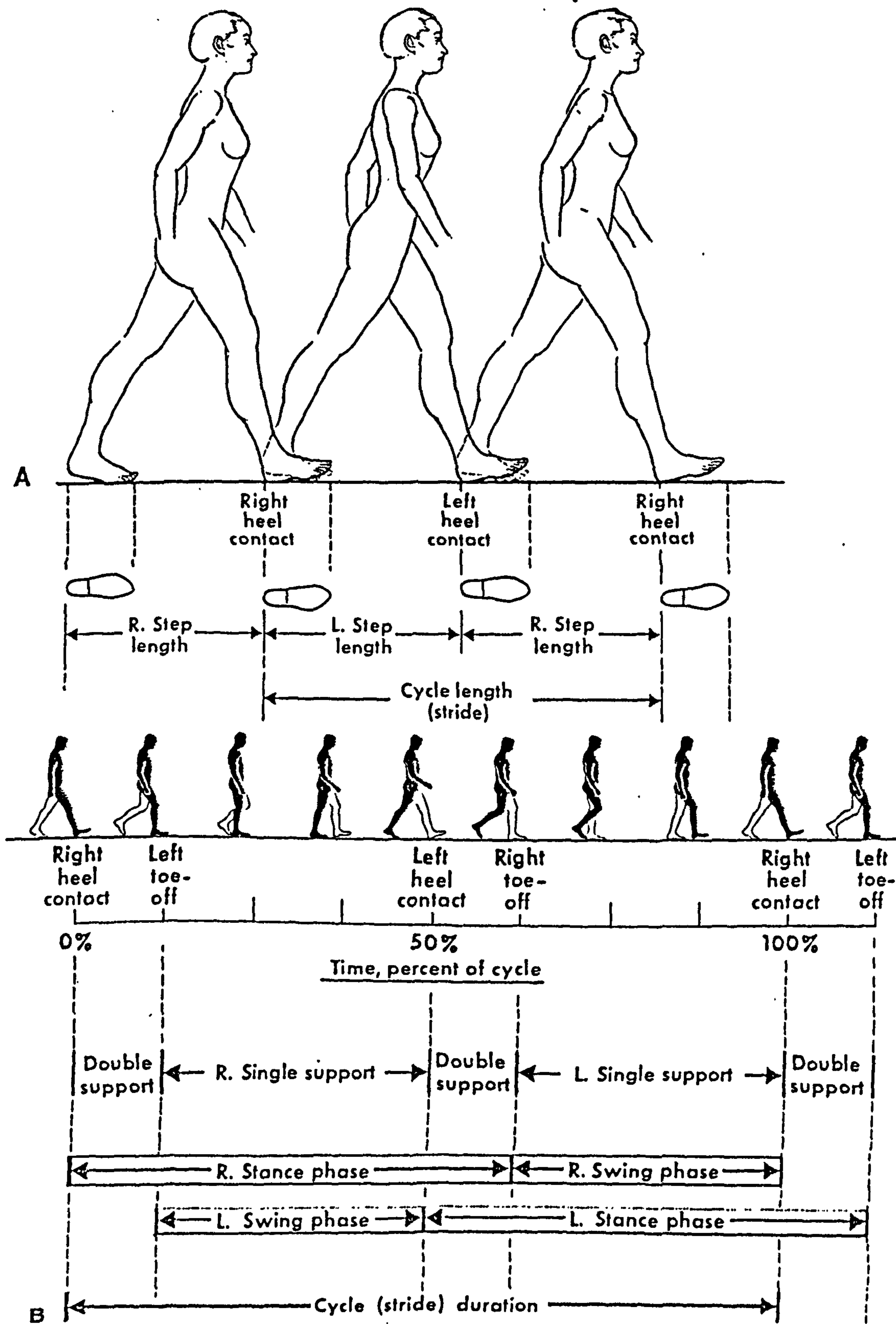

Figure 2 Phases of the gait cycle (Inman et al 1981)

The swing phase is marked by an early accelerative period immediately after toe-off allowing the leg to get ahead of the body. A final decelerative phase which controls the velocity of the limb segment is separated from the initial portion of the swing by a loosely defined mid-swing phase.

From this brief resume of the gait cycle it might appear at first sight that gait itself is a simple act, but the classification above only serves to aid our separation of the cycle into manageable parts. Added onto this are the problems we encounter when we try to analyse a cycle of gait from a patient with impaired mobility from whatever pathology.

Numerous approaches have been made in an attempt to quantify gait and hence to give it an objective treatment, some yielding kinematic and others kinetic data. A segmental approach to gait analysis i.e. movement in space of body parts, is a major area of study (Murray 1964, 1969 a post war fore-runner in this field), which when coupled with kinetic data (Elftman 1939 one of the first workers to use this methodology) or with other kinematic data (Morrison 1968) makes for a comprehensive assessment of gait.

Brand (1981) in his letter to the editor, highlighted the limitations which we must always be

aware of when evaluating gait, using biomechanical tests. The clinicians observations and other tests he has at his disposal, are used to make diagnoses and routine clinical decisions. The tests the biomechanist employs, often using very sophisticated equipment, merely aid in the evaluation of a musculoskeletal disturbance. The temptation to attribute these tests with diagnostic powers must always be resisted. They merely, "...help determine the severity of the disease or evaluate one parameter of the disease." (Brand).

He continues by pointing out several factors which those involved in developing gait analysis techniques must be aware of. They are as follows:-

1. The measured parameter(s) must correlate well with the patients functional capacity.
2. The measured parameter must not be directly observable and semiquantifiable by the physician or therapist.
3. The measured parameter must clearly distinguish between normal and abnormal.
4. The measurement technique must not significantly alter the performance of the evaluated activity.

5. The measurement must be accurate and reproducible.

6. The results must be communicated in a form which is readily identifiable in a physical or physiological analogue.

A technique cannot hope to gain widespread acceptance if it not useful, so throughout this project the above recommendations and those of Laycock (1976), below, will be referred to.

Cappozzo (1983) talks about some of the objectives of gait analysis, assuming availability of suitable data capture techniques. (Referencing Brand (1981).). He does this with particular emphasis on gait analysis in the clinical setting. He advocates a move back to a more scientific approach, with the aim of answering the 'whys' and not just 'how' man walks. Our analysis techniques should, he states be looking at the strategy of motion that the patient adopts. This strategy is dependent upon the functional and structural constraints imposed by the patients disability, secondly, and his ability to put together a locomotor act. Satisfactory performance of the locomotor act along with it's consistency can be assessed by looking at the parameters below, and this, states Cappozzo, is a measure of the quality of the gait that the patient

can produce. These terms which are a measure of function are as follows:-

1. Maintenance of balance
2. Mechanical load on tissues
3. Energy expenditure.

Comparison of patient mobility with normal gait need not always be made in the literal sense. It can be assessed in terms of the patients ability to effect a pattern of locomotion compatible with his needs. Instead of continuing to amass vast amounts of data on human locomotion, we should concentrate on attempting to explain what we observe. To do this we must start to interpret the data we collect with our sophisticated equipment, in a more scientific manner (Cappozzo 1983). We may then be in a position to answer some of the questions about why man moves as he does, and not only how he performs his locomotor act.

In the clinical setting evaluation of gait is useful in order to assess the effectiveness of surgery, the behaviour of endoprotheses and the suitability of particular physiotherapy regimes. The particular problems that were presented at the outset of this project involved developing a method or methods of

quantifying the loads and movements at the knee joint, whether in the natural or prosthetic knee. It was also a requirement that the technique developed followed the guidelines laid down by Laycock (1976) regarding the design of methods for gait analysis, namely

1. Should give a quick qualitative impression of the subject's walking style.

2. Should give accurate objective information and must not interfere with walking.

3. The record should be made within 5-10 minutes with only semi-skilled assistance.

4. The plot of the gait should be preservable so that future easy inspection can be made.

This literature review will give an overview of the "State of the Art" of knee joint force determination and measurement of joint movement about the sagittal, coronal and horizontal/transverse axes. It will discuss some of the methods used along with the assumptions made, particularly in knee joint modelling. It will also talk about the data that can be obtained using these various methods as well as their drawbacks and finally relate all this to the gait assessment



technique to be developed in this project.

A few paragraphs will be devoted to a discussion about the available methods of giving an "Index of Knee Function" to a patient and this too will be linked to our attempt at quantification of knee function.

Before embarking on this project it was necessary to become familiar with the anatomy of the Lower Limb, particularly those structures involved in providing knee joint stability. (figs 3 to 6) Several texts were found to be of particular use including Gray (XV Edition), Kaeandji (1970) and amongst the more applied books Rasch and Burke (1978).

Two classic papers, Fick (1911) and Brantigan and Voshell (1941), give us a base line from which to work, both of which, using cadaver material, highlighted the contributions made by various structures in and around the knee joint. Both studies allowed a description of structural activity when the knee is in varying degrees of flexion/extension and varus/valgus. Their work has been updated by the development of instruments designed to apply stress to and record displacement of the ligaments and menisci of the knee (Seering 1980 Pizzali 1980). Wang and Walker (1974) used cadaver material and applied torques and axial loads to the joint, producing measurable rotations and reduced rotatory

Figure 3 Right femur posterior surface

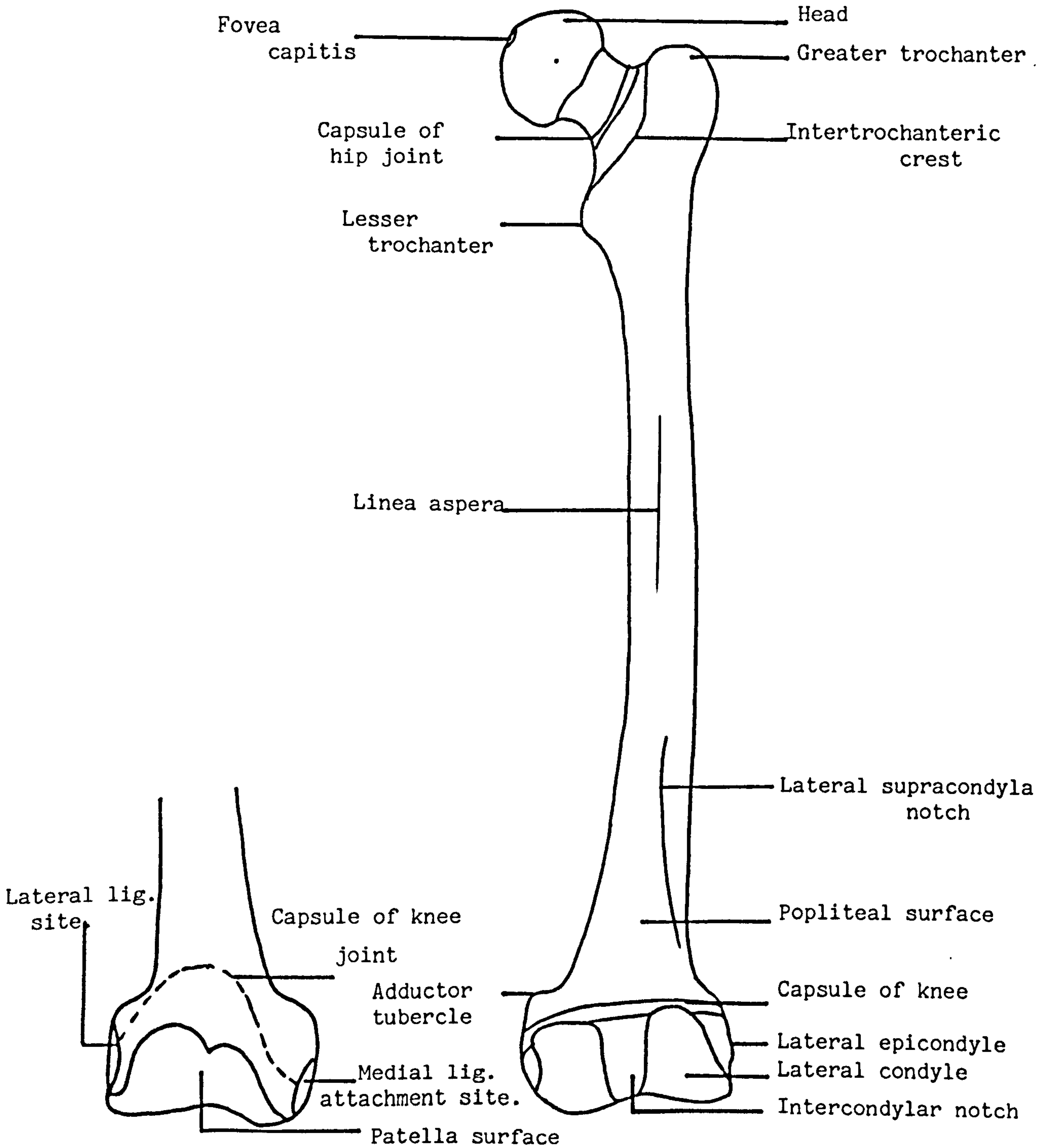

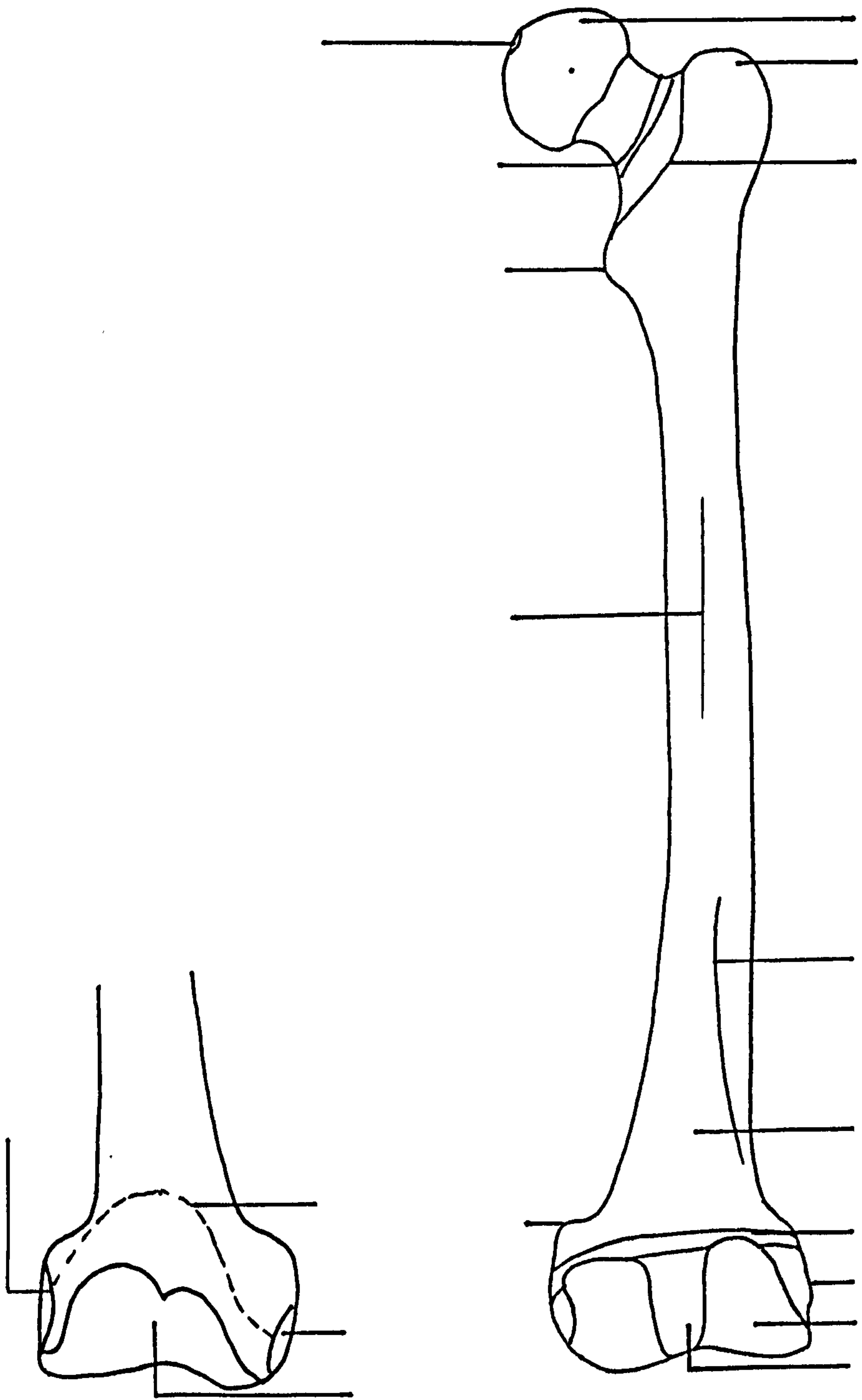
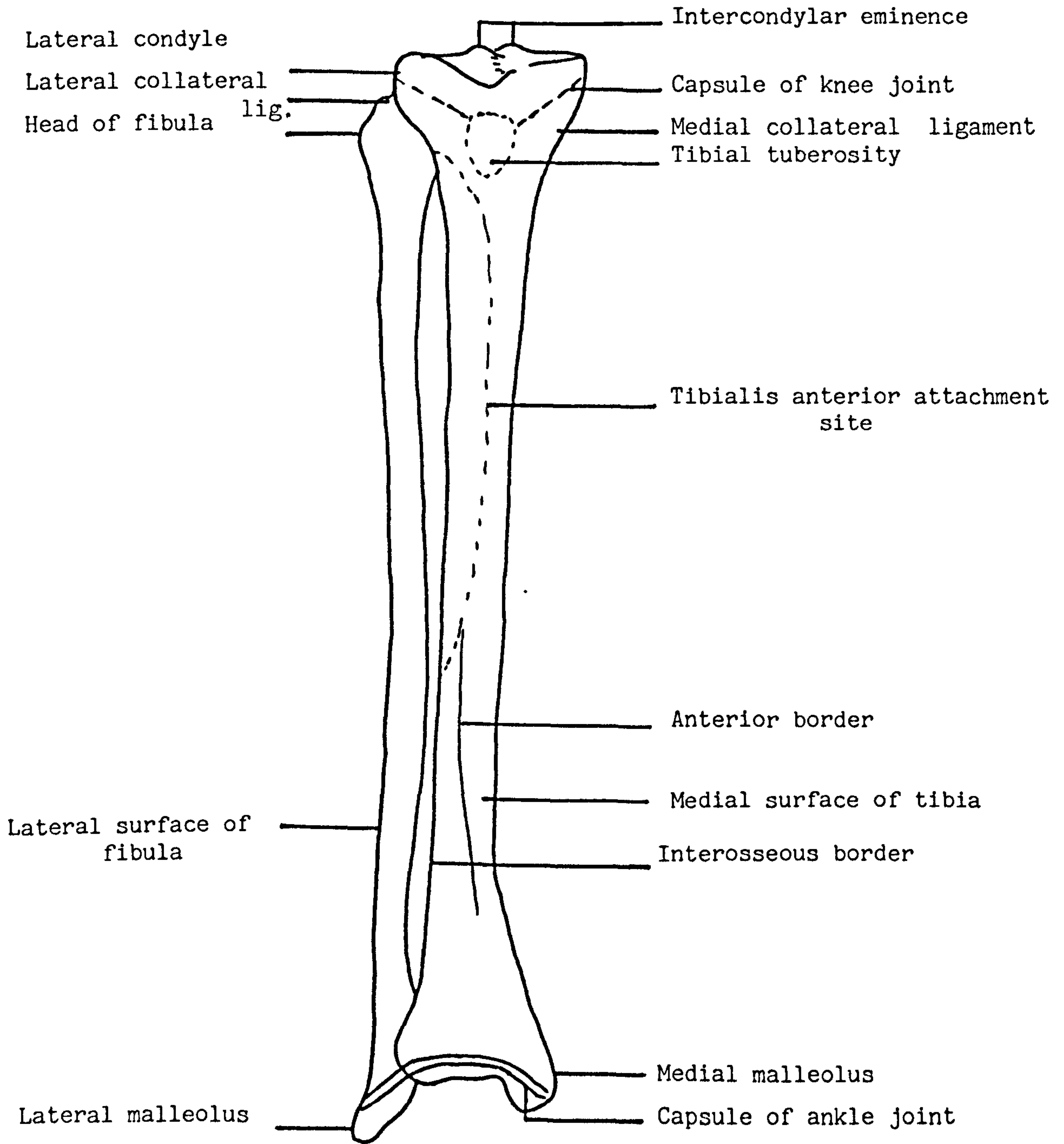
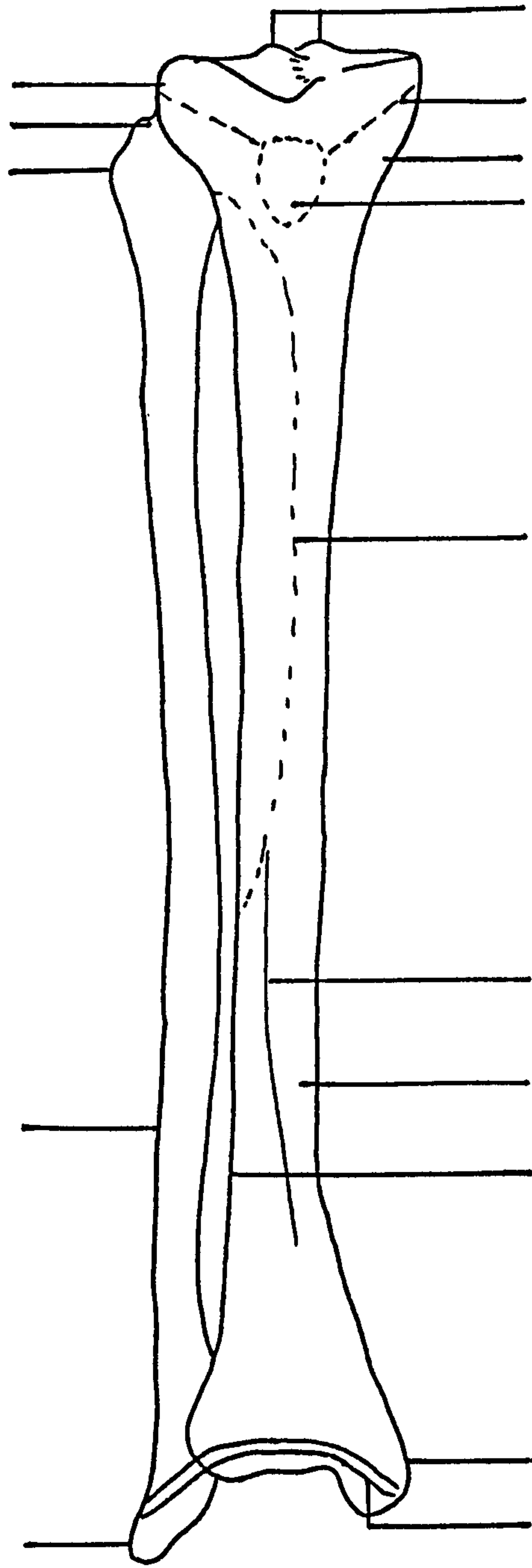

Figure 4 Right tibia and fibula anterior surfaces





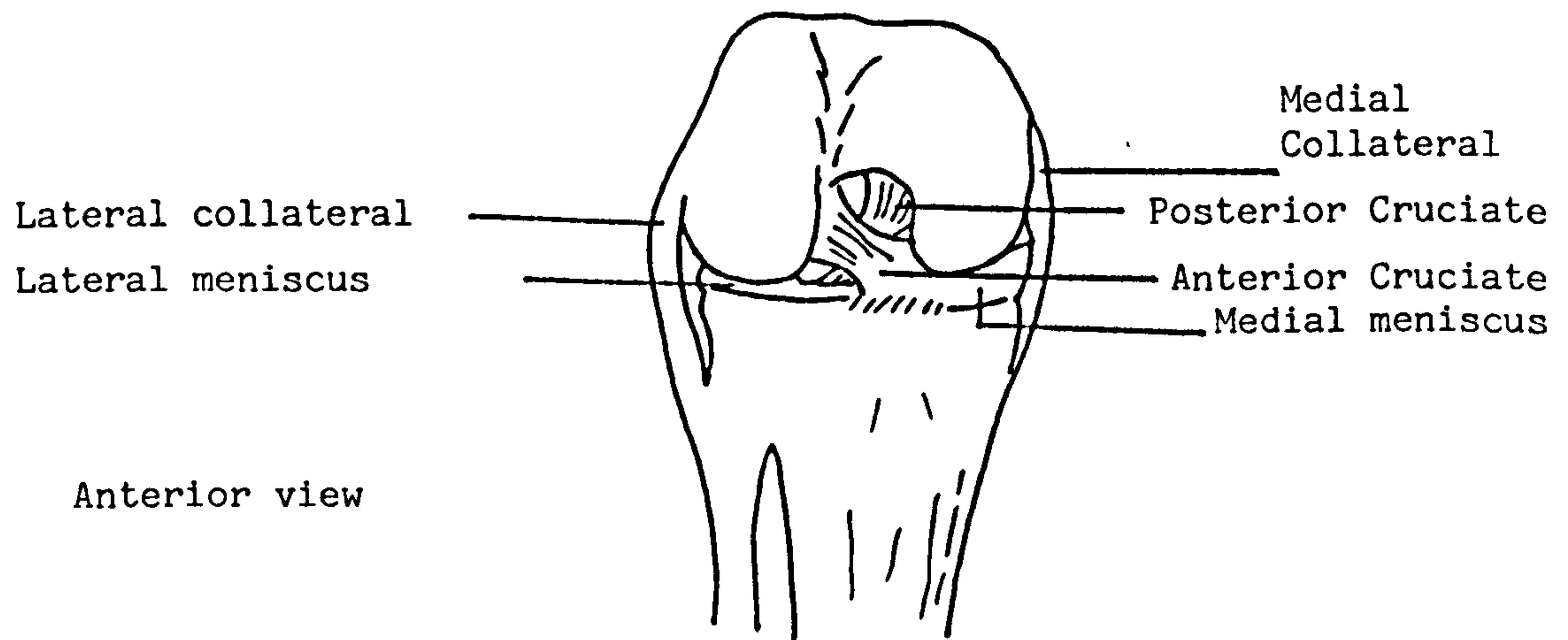
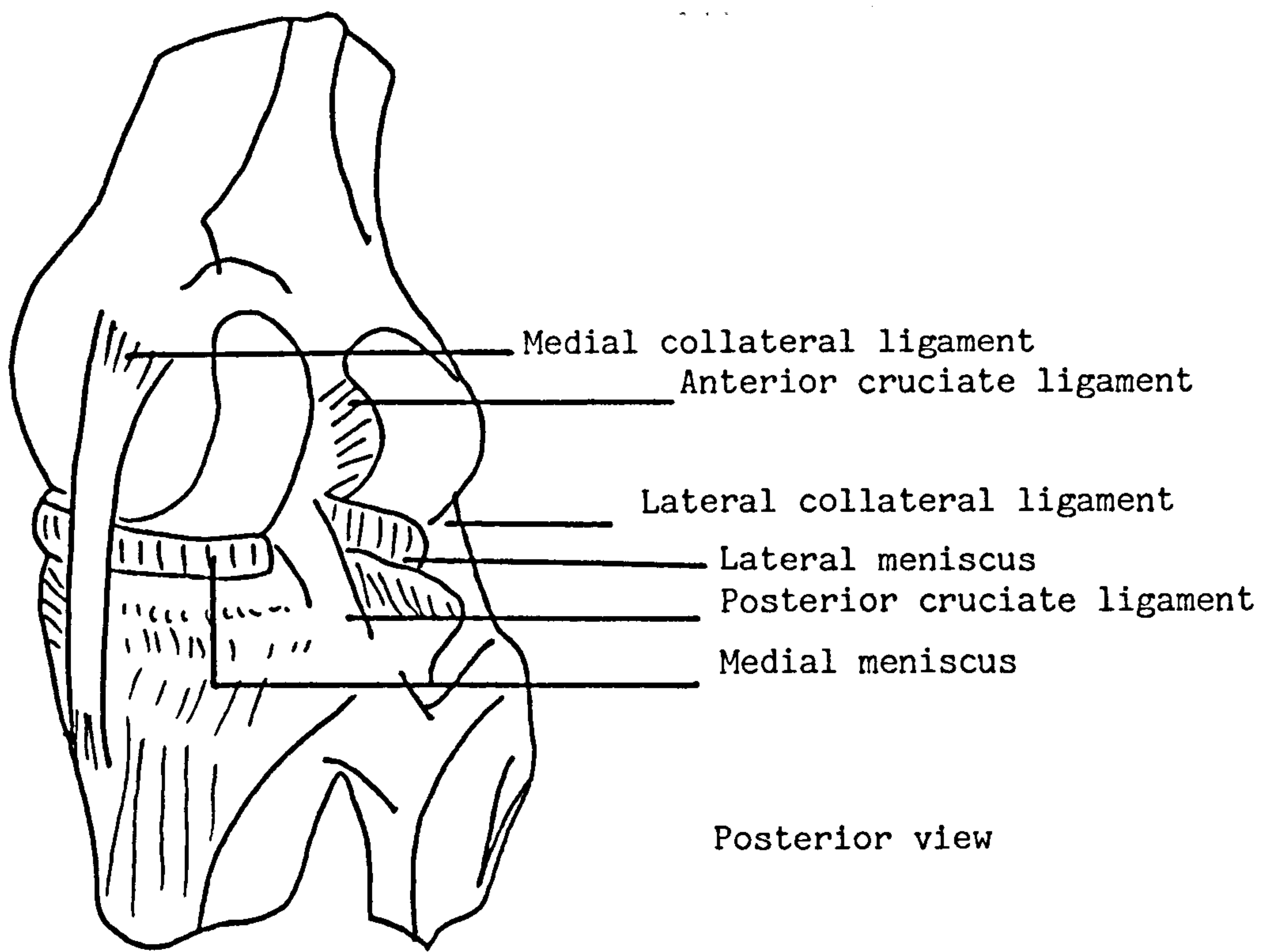
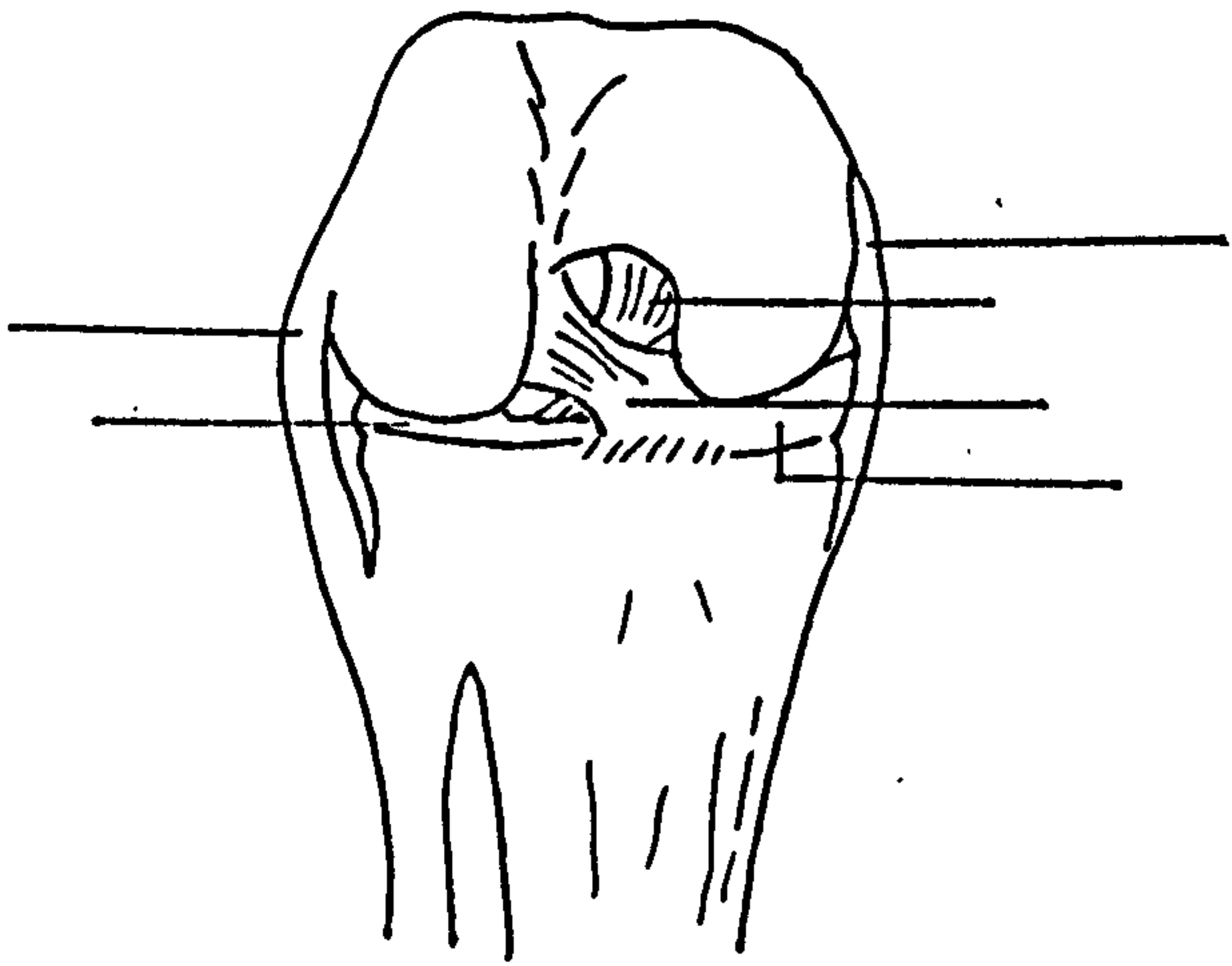
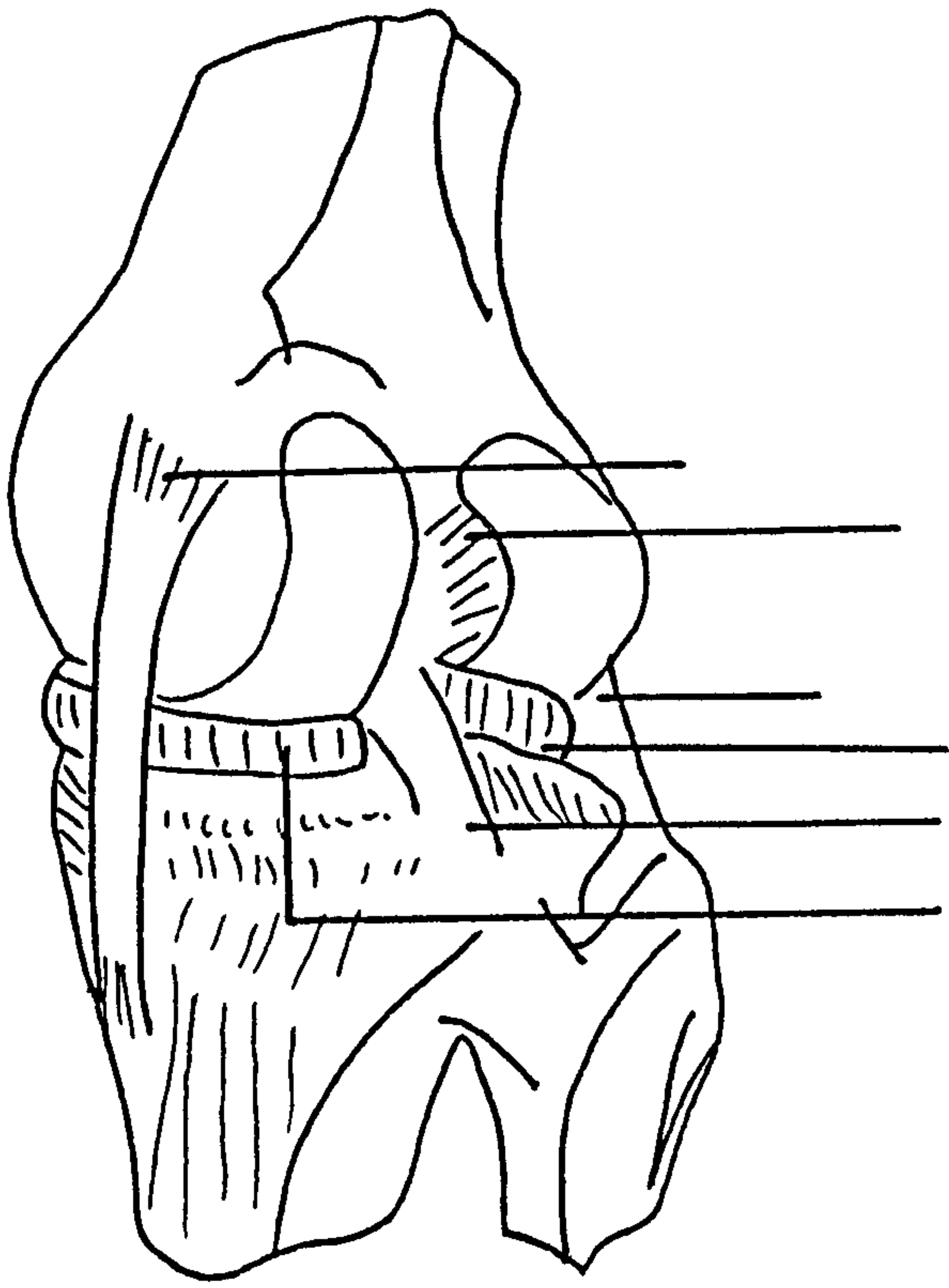

Figure 5 The knee joint



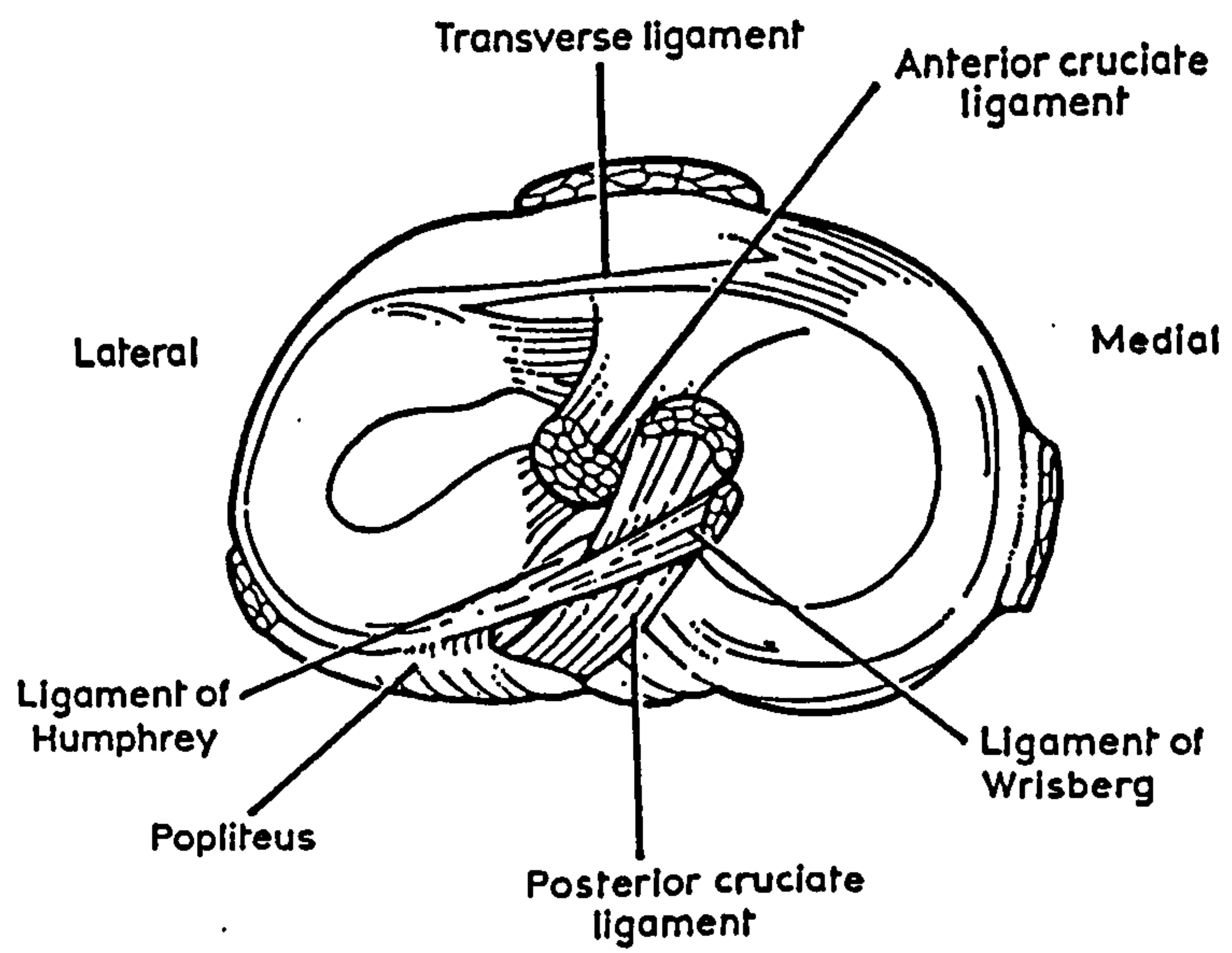

Figure 6 Upper surface of the tibia (Heller and Langman 1964)



laxity (a function of ligament and meniscal activity).

In vivo studies have necessitated subjective assessment of joint laxity with typical clinical tests including the drawer sign (Hoffenfeld 1976) for anterior/posterior laxity. Work published describing knee laxity and pathological structural alterations include papers by Chick (1978) Fetto and Marshall (1981), Lipke (1981) and Levy (1982). Standardised terminology and classification of these instabilities were developed (Hughston (1976)), with documented clinical evidence presented to support their work. (Hughston and Barrett 1983.)

Stress testing machines eg. CYBEX II (Nomen Ltd.) and the Arthrometer (Medimetrics), have been employed to evaluate knee stability/laxity in normal and damaged joints. Quantitative information on cadaver material by Fukubayashi (1982) and live subjects Torzilli (1981) and Shoemaker (1982) give joint displacements and degrees of tibial rotation during antero-posterior motion under applied torques.

#### KNEE JOINT FORCE ESTIMATION

There have only been a few studies where knee joint forces are measured directly, notably Frankel and

Burnstein (1971) and Perry (1975), who both incorporated force transducers into knee joint replacements. However no work has yet been published on direct measurement of forces in the normal healthy knee - the ethical and practical problems obviously preventing this.

Hence it has been necessary to perform indirect three dimensional analysis of forces transmitted at the knee. Experimentation is now at the stage where the dynamic position of the line of action of the resultant ground-foot force can be determined and, with a knowledge of the spatial orientation of the knee, and making assumptions and simplifications about muscle and ligament action, the loading of the knee joint can be quantified. (Including Ellis et al 1984, Jarret et al 1980 and Tait and Rose 1979.)

The methodology used involves measurement of foot-floor reaction with a force plate, several of which are on the market (Kistler, AMTI). These generally give a voltage output proportional to the force exerted on the plate three orthogonal axes and the moments about one or more of these axes. Spatial orientation of the limb can be observed by cine-photography using bony landmarks or estimated centres of rotation. Alternatively goniometric devices e.g. Polarised Light Goniometer or Electrogoniometer provide

details of the angular orientation of limb segments relative to one another. Combining these data and fitting them into a mathematical model of the knee allows estimation of the total force during gait (Morrison 1968). Obviously to model the knee joint simplifications and assumptions have to be made. The validity of these assumptions will be discussed later.

Many models of the knee have been devised, some of the simplest systems (Morrison 1968) comprising three muscle groups and four ligaments across the joint, and other more sophisticated models (Chao 1980) describing the knee in terms of Eulerian angles, referred to as a three-axis or gyroscopic system. Harrington (1976) proposed a model to determine the knee joint forces, making several assumptions about ligamentous tensions and muscle action. He only looked at the stance phase of gait and excluded from his model gravitational and inertial forces. Work by Paul (1965) and Morrison (1968) showed that maximum joint loading occurs during the stance phase and that swing phase loading is due to the effects of gravity and inertia only. A more detailed look at three papers typical of the approach now being used to study knee joint forces will follow, particular attention being paid to the assumptions in each case.

Harrington (1976).

In an attempt to simplify the force actions at the knee the cruciates were assumed to resist only antero-posterior displacements whilst any tension in the anterior cruciate is accompanied by no tensile force in the posterior cruciate and vice-versa. The cruciates were also assumed not to transmit moments in either the sagittal or frontal planes, and that there is no antagonistic behaviour between the flexor and extensor compartments of the knee. A single line of action is assumed to represent the integrated contraction of muscle fibres comprising a major muscle group e.g. hamstrings, quadriceps, gastrocnemius. The direction of this single line of action was determined theoretically from cinefilm data and anatomical considerations of the knee.

The centre of joint pressure, which varies with the degree of abduction/adduction of the tibia (in the coronal plane), was assumed to have a limiting value equivalent to one quarter of the knee condylar width, this being measured from the vertical tibial axis which passes through the knee joint centre. This assumption allows for three variations in contact between femoral and tibial condyles. Two involve one point bearing contact, with the resultant joint force concentrated either medially or laterally, and the third involves two point contact, the load being distributed between medial and lateral compartments.

Harrington justified excluding the gravitational and inertial effects of the limb segments from his model by calculating their effect on the fore and aft knee moments in the sagittal plane during "fast" walking. Their influence was considered to be small enough to be omitted from his calculations, as did Bresler and Frankel (1950) Morrison (1968).

The assumption of tension being present in only one cruciate at a time is questionable. In two conditions,

1. In knee flexion of greater than 90 degrees and,

2. When the joint is actively separated,

there has been found to be tension in more than one cruciate. (Steindler 1955). Although in normal walking these conditions are generally not found, their effect on tension in the cruciates should be borne in mind when dealing with the pathological knee.

Non-antagonistic behaviour of muscle groups around the knee joint has been assumed in order to model the equilibrium state of the knee, where external forces are matched with forces between the tibial and femoral condyles and force actions in the muscles and ligaments. Electromyographic studies have shown that antagonistic behaviour occurs for approximately 10% of the gait cycle, mostly at heel strike (Harrington

1976). The same author also suggests that the hamstrings and gastrocnemius function at different stages of the walking cycle and never together, this being supported by Inman et al (1981) and Paul (1974). This allows calculation of force actions in either one or the other of the muscle groups. (One exception to the above statement is when the individual stands still on tip toes when both the hamstrings and gastrocnemius are active (Paul (1974)). Detailed accounts of electromyographic studies of muscular activity during the gait cycle have been published by several workers including Joseph (1960) and Carlsoo (1972). These should be referred to for a definitive explanation of their methods, techniques and results.

In Morrison's (1968) paper moment arms for the respective muscle groups are assumed to be calculated by scaling data obtained on muscle origins and insertions, presumably collected from cadaver material. The accuracy of the resulting muscle force (calculated from total moments and these scaled moment arms) is undefined in their papers i.e. those of Morrison (1968) and Harrington (1976).

This issue of a single line of action of a muscle group and the direction of the resultant force remaining constant regardless of intensity of muscle action, are two assumptions whose effect upon resultant

Location of joint force are unknown at present. No doubt electromyographic work could shed some light on this area. It should be highlighted here that Morrison omitted from his calculations the actions of the tensor fasciae latae, gluteus maximus and popliteal muscles. Again this was justified by the results of electromyography and the need to simplify the knee joint model.

Kettlekamp (1972).

Kettlekamp and Chao (1972) chose a free body diagram of the leg through the knee joint, employing a frontal plane analysis to predict resultant force distribution between the joint surfaces during standing. Again to compensate for lack of knowledge of specific functional anatomy, several assumptions had to be made. A "normal" foot was assumed, which would have no effect on the forces transmitted through the knee. It was assumed that in the varus or valgus knee passive forces of the medial collateral ligament or the combined resistance of the lateral collateral and iliotibial tract come into play. The orientation of these two sets of forces was assumed to act at a fixed angle with respect to the femoral mechanical axis. In the case of one point of contact Kettlekamp assumed this point to remain at the centre of the arc of the contact surface of the tibia, with varying tibial

angles.

As with previous workers Kettlekamp had to make several questionable assumptions. An arbitrary assumption is made regarding the floor reaction force in that it is presumed to act vertically through the centre of the ankle joint, this assumption can be verified from force platform information. He also sets the centre of gravity of the leg to be at the mid-point of the tibial axis and a fixed percentage of body weight was used to determine segment weight. These two assumptions no doubt lead to errors in calculated values of medial and lateral loading, the former assumption more so than the latter. Kettlekamp would have been better advised to use Dempsters (1955) results to locate the centre of mass of the calf as well as to determine segment weight.

Roentgenographic work was used to determine origins and insertions of ligamentous structures around the knee. Obviously this method leads to inaccuracies due to human error in analysing x-ray material. As with Harrington (1976) and Morrison (1968) assumptions had to be made but again the degree to which these affected the variables in question was not quantified.

Nissan (1980)



Nissan (1980) reviewed some of the above assumptions. Using a specially devised computer program he has analysed the internal equilibrium at the knee. It allowed him to alter muscle and ligament origins and insertions, lines of action and points of application of forces. His results are itemised below. Quantified results of his work can be found in his PAPERs.

1. Intercondylar force (IF) is highly sensitive to small changes in its point of application anteroposteriorly (A-P) although generally taken to lie along the mediolateral (M-L) axis in the tibial plateau.

2. IF is sensitive to location of joint centre (defined in terms of geometric relation to skin markers) particularly in the M-L and A-P directions.

3. IF is not significantly altered by change in insertion of the quadriceps or by the addition of an M-L component (justifying Morrison's assumption about confining quadriceps to the sagittal plane).

4. Exact location of ligament insertions were found to be unimportant.

5. Use of balanced in-phase activity for the

gastrocnemius and hamstrings was verified by moving the insertions from one side to another.

6. Asymmetric, antagonistic and multiple ligament loading exists in level walking.

It had been stated earlier (Nissan 1980) that the internal kinetics of the knee cannot be solved adequately without a good model plus knowledge of the spatial orientation of the knee. Johnson et al (1981) have suggested that spatial information of better than  $\pm 2\text{mm}$  is required for gait analysis. Methods for determination of spatial (3D) orientation will be reviewed in the following section.

#### Summary

It can be concluded that some of the assumptions made are acceptable whilst others may well have a considerable effect on the end result i.e. loading of the knee joint. Unfortunately very few of the workers attempt to quantify their errors and others seem to be oblivious to the inaccuracies in their work. Harrington (1976) gives a  $\pm 20\%$  overall figure of accuracy to his work. Johnson and Waugh (1979) itemise the following, 2% accuracy for force plate,  $\pm 1\%$  for the analogue to digital converter, cross-talk between channels  $\pm 2\%$  and goniometric accuracy  $\pm 2$  degrees.

Published values for knee joint forces include the following (tibio-femoral forces) Morrison (1969), 3.05 to 3.73 times body weight (tbw); Harrington (1976) 2 to 5 tbw; Johnson and Waugh (1979) 6 tbw; Maquet (1976) 4.2 to 6 tbw (dependent on the assumptions made). All the figures quoted are for level walking, for a review of maximum forces during other activities see Swanson (to be published).

#### KNEE JOINT ROTATION

There are a wide variety of tools available which yield various types of information about the rotation and spatial orientation of body parts. The range of complexity and hence cost of these devices also varies enormously e.g. a single axis electrogoniometer can be acquired for a few pounds (Finley and Karrovich 1964); the polarised light goniometer (Crane Electronics) was around 4,000 pounds (1983); CODA-3 (Movement Techniques Ltd.) costs around 30,000 pounds; the television-computer system VICON (Oxford Medical Systems) is on the market at 58,000 pounds (1984). Increasingly the cost of equipment must be weighed against the detail required. So far the ideal system has not been developed so when choosing a technique several factors have to be weighed-up against one another. Winter (1979) suggests the following pros. and cons. for consideration:-

1. Capital outlay and running costs.
2. Encumberment to gait.
3. Time to set-up and calibrate.
4. Availability of data for analysis.
5. Data format.
6. Extra considerations e.g. lighting and range (hence need for telemetry in some cases).

He then draws up a table to compare five well known techniques, bearing in mind the points above. (see table 6).

The following discussion of equipment does not claim to be exhaustive but highlights those systems which the author thinks appropriate to this study.

The conventional clinical tools for measurement of static range of movement (i.e. maximum flexion/extension and degree of valgus/varus) include the goniometer manufactured by Zimmer Orthopaedics Ltd. and modified by Waugh (1979). This goniometer possesses extensible arms to allow for more accurate alignment with the palpated bony landmarks. A

Table 6 Comparison of five well known techniques used for data capture in human kinematics. (From Winter 1979).

Considerations	Conifometers	Accelerometers	Cinematography	Television	Multiple Exposure
Cost Capital + Running	Low, except cost of pen or tape recorders	Expensive; including cost of electronics and recorders	Moderate, except cost of conversion equipment	Moderate, cost of conversion is high	Low
Encumberment to gait	Can encumber if many are used	Can restrict movement if many are used	Minimal	Minimal	Minimal
Time to attach and calibrate	Can be excessive to attach and calibrate	Can be excessive to attach	Minimal to attach markers	Minimal to attach markers	Minimal to attach markers
Availability of Data for Analysis	Instantly available	Instantly available	Development of film and conversion of data can be high	Instant replay, has capability for instant conversion	Instantly available
Data Format	Assumes hinge joint relative angles only	Absolute direction of acceleration not known	Absolute coordinates	Absolute coordinates, maximum field rate of 60 Hz	Overlapping of exposures limits accuracy and frame rate
Other Considerations	Unless telemetry is used, range and speed of activity are restricted	Unless telemetry is used, range and speed of activity are restricted	Extra lighting required indoors; permanent visual record available	Extra lighting required	Low flashing rates are distracting, darkened room required

standardised method of use as described by Waugh is necessary to give greater accuracy to the recorded measurements, particularly the interobserver variability needed to be reduced.

A second type of instrument which is discussed below allows us to record the gross movements of a joint as opposed to purely angular movement. Both planar and 3D motion measurement will be discussed although our attention will focus on 3D measures of joint rotation.

### Goniometers

As mentioned there are a number of goniometers available for the measurement of joint rotation, capable of detailing the movements of limb segments in the sagittal, coronal and transverse planes. Karpovich (1960) described a simple electrogoniometer (elgon) for measurement of ankle and knee rotations in the sagittal plane. The potentiometer on which the elgon is based has an output which registers the degree of flexion/extension, the elgon being placed at the joint of interest. Problems of location and movement of the elgon relative to the limb are its major drawbacks.

A more sophisticated version of the goniometer is the Polarised Light Goniometer (Polgon) (Grieve 1969,

Reed and Reynolds 1969). Polarised light emitted from a projector is sensed by receivers attached to limb segments. The time interval between output pulses of the projector and receiver is utilised to derive a measure of the angle between adjacent or non-adjacent body parts (Mitchelson 1975, 1977). It is more easily attached to the subject than the Polson, not requiring location in relation to the instantaneous centres of rotation of joints. It allows for measurement of angles at 100 Hz, the data from it comparing favourably with that from analysis of cine-film. Reported accuracy is within the order of  $\pm 2$  degrees (Johnson and Waugh 1979). Clinical studies which have employed this system include Arnell et al (1982) who investigated the parameters which may be derived from Polson data and looked at the clinical relevance of these parameters in relation to biomechanical variables. Corston et al (1981) used the Polson to investigate changes in knee and ankle angles of spastic patients undergoing drug therapy.

The electrogoniometer has been extended by Chao (1980) to measure rotation of limb segments along three axes. This system is called triaxial goniometry and is based on mathematical Eulerian angles and is also referred to as the 3-axis gyroscopic system. The goniometer axes do not coincide with joint axes and hence the errors incurred have to be determined

theoretically. The accuracy of the apparatus was assessed by comparing the calculated angles (knowing the orientation of the two reference frames) and the measured angles. This is carried out on a joint model to yield identical joint orientation so that relative accuracy can be determined. A mean error of less than two degrees for all angular components was deduced. A correction for cross-talk (difference between actual joint motion and sonometer measurements) as developed by Chao was based on modelling of the system as a spatial linkage, and solving it by the 4x4 matrix method. Recommendations for mounting positions are also given by Chao in what appears to be a well thought out paper, including all sources of possible inaccuracies.

Another elson called the C.A.R.S. - U.B.C. electrosonometer consists of three potentiometers (20k ohms, 1% linearity) mounted in a parallelogram chain system. Angular rotations only are registered and the apparatus is reasonably self aligning. It has the advantage of being lightweight and completely portable. However it has to be aligned accurately to reduce cross-talk (between flexion/extension and varus/valgus). At heel strike there appears to be a degree of noise, which, suggests the authors (Godfrey and Falconer 1980), may be part of the gait cycle proper. Further work will no doubt have to be carried out to validate this tool. Hannah and McGraw (1980)



have presented work using the C.A.R.S. - U.B.C.elson to assess total knee arthroplasty but do not give details of reliability studies carried-out on their equipment.

Townsend et al (1977) describe a soniometer of electromechanical type along with a computational technique for quantifying knee joint motion. Townsend points out the problems associated with correct fixation of markers which form part of the external spatial linkage system upon which the equipment is based. The paper suggests a method for relating the linkage motions (registered by the equipment) to the anatomical motion to yield kinematic data relating to knee joint activity. Radiographic results suggest that movement of the attachments relative to the femur and tibia have a maximum value of 1/8 th of an inch which is assumed to be a consistent error and allows assumption that the soniometer is fixed. Townsend suggests that recomputation of reference vectors occurs for each test. As long as the attachments do not move during the test, it may be that attachment is less critical than for other designs. Using computerised data analysis and reduction, data can be collected for general analysis of knee characteristics, although visualisation is of diagnostic value. The system is lightweight (0.68 kg) and moderately inexpensive the major drawback being that of fixation, at present being

carried out by suction cups.

The point must be made that however reliable the data collected by soniometric means may be, there still remains the problem of data analysis. Grieve(1968) suggested angle/angle diagrams the shape of which allows detection of abnormalities. Hershler and Milner (1980) presented methods of quantification of these loops (angle/angle plots) to provide "estimation of abnormality". This numerical analysis performs the calculation of perimeters, areas and ratios of these values, using specifically written software.

Television and camera based devices.

Television has been utilised in a number of techniques to automatically track markers placed on the body. SELSPOT (selective light spot recognition) was first described by Woltring (1974) and is manufactured by the Selective Electronic Company. It is a commercially available system, employing sequentially pulsed LED targets mounted on the subject, with computerised data collection allowing for combination with force plate data to yield knee joint loading information. Reference to Woltring (1980) details the principle of operation.

Drawbacks of this method are that wired body

markers are required and electronic signal to noise ratio is a crucial limitation. Spurious reflections of light causing interference is another problem and the author has suggested measuring the quantity of reflected light and subtracting this from the signal. Image distortion resulting in low frequency noise is of less significance than the high frequency noise associated with distance variation and quantization when estimating velocity and acceleration from displacement data. Movement of markers due to structures overlying the bone is, as with all these measuring devices, a problem. At present SELSPOT seems to yield useful information for clinical assessment of knee joint loading, having a resolution of 1 in 4000 and an error less than 1 part in 200.

Andriacchi (1979) described an opto-electronic system comprising two cameras and an electronic signal conditioner. The positions of six LEDs mounted on the lower limb and used as reference points were sampled at a rate of 75 Hz and computation of their 3D co-ordinates carried out. His work is based on the assumption that polynomial functions exist that can account for distortions arising from the 3D location from a planar image.

A third system which claims to iron-out some of the problems associated with these optoelectronic

remote sensing devices has been developed by Macellari (1983). The system called CoSTEL an acronym for 'Spatial Co-Ordinates for Linear Electrical Transducers' has yet to be used outside the laboratory but is reported to be able to track eight landmarks simultaneously with a resolution of 1 in 4000 at a 100Hz sampling rate. Results from clinical investigations using this system are yet to be documented.

As mentioned earlier Boccardi et al (1981) developed a system to analyse the muscular moments at the lower limb joints during human locomotion. Using a force plate, TV cameras and a hybrid computer they produced, on-line, superimposition of the vector representing the ground reaction force onto the image of the subject walking. An estimate of the moments at the ankle knee and hip joints then follows, by approximating total moment at the joint to the moment due to ground reaction. The authors point out the differences in reliability of the results depending upon the joint being investigated. The effect that speed of gait has on inertial and gravitational factors adding to the unreliability of the technique are also considered.

They conclude that this relatively simple method agrees well for the ankle and knee, with other more

sophisticated techniques but that for the hip there are striking dissimilarities. These differences are put down to the inertial components arising due to acceleration and deceleration of the leg. The technique described is relatively simple to carry out, takes little time and does not encumber the subject. The slower cadence of patients with locomotor pathologies is, suggests the authors, likely to be more suitable for this approximation technique than the higher cadence of their 'normal' test subjects.

Morasso and Tagliasco (1983), used mirror stereophotogrammetry to investigate the kinematics of the arm in experimental work stations. The system consisted of one camera and several mirrors, to give a multi-perspective view, similar to that developed by Woltring (1980). Algorithms were used to solve for camera calibration and space localisation. The system was developed to work over a large range of postures rather than to give high absolute precision. Problems of which the authors were aware included that of markers becoming hidden, difficulty in quantification of errors and the laborious task of digitisation by hand to acquire the data points. They went on to point out that ideally X-ray stereophotogrammetry would be used within joints (see Lippert et al 1978) and that computerised digitisation would assist in making this system a viable method on on-line analysis of body

movements.

Milner (1973) used a polaroid back camera and a stroboscopic flash unit in a darkened room to obtain "strobe" sequences for total hip replacement candidates. A Vanguard motion analyser allowed plotting of angle-angle diagrams. A step on from this using a movie camera, Kasvand and Milner (1972) employed a computer system to control a flying spot scanner and yield similar data to the above. Winter et al (1972) used video taping with the advantage of data being available for immediate processing which can be digitised via a TV-computer interface. A resolution of 1mm is reported.

Kasvand et al (1976) suggested in their paper that methods of data capture including still or movie photography, television or electronic means can all be subjected to computerised data analysis and reduction to yield clinically useful information about human locomotor function. In their paper they discuss the merits of the above techniques, the numerous display possibilities and in particular the use of angle-angle diagrams in patient assessment.

Both Chena (1974) and Jarret (1976) have expanded this idea of interfacing TV systems to a computer system. Chena reports a resolution of 1 in 240 for

marker location. Jarret manages to increase the resolution to 1 part in 300. A modified version of this system, VICON (Oxford Medical Systems), has now been marketed.

VICON utilises up to seven standard television cameras and specially designed software to measure the three dimensional position of a set of conical markers coated with retroreflective film. Infra-red strobes with a flash duration of 2 milliseconds provide the light source. It is reported that from almost any angle the light is reflected back, by the marker to its source. An average of 25 markers are thought to be practical. The software allows graphical display of relevant marker trajectories. Spurious points due to reflections or background images are automatically discarded when the marker labelling stage takes place, i.e. when the operator identifies each landmark. All data are stored on file and can be recalled and looked at in conjunction with electromyographic and force data.

Three dimensional tracking devices.

Shroff et al (1976) have reported the preliminary use of three dimensional tracking of body parts by ultrasonic means (UNOPAR). The apparatus consists of an ultrasonic transmitter-receiver system (at present

possessing only one channel), capable of measuring distances of up to six metres with a resolution of 0.1%. This resolution is hoped to be improved using acoustic matching techniques. A maximum of six points can be monitored at one time, the total processing time for 50Hz repetition rate and 10 secs. of monitoring is approximately one minute. Further developments of this system are yet to be published.

Kemp et al (1982) used a Doppler radar device to collect information on the involuntary body movements associated with choreoathetoid syndromes. When monitoring these movements the system takes into account the length of motion and size of the body part involved, hence giving an index of the burden exerted by the involuntary displacements the body. A trace derived from an electrical signal contains all the information on the movement and has been used clinically to measure the effectiveness of drug treatments. The main drawbacks of this system are that the field of operation must be free from large metal reflectors, fast moving large objects and all fluorescent lighting must be excluded. Bearing in mind these limitations the system appears to be a low cost, simple device giving an on-line measure of body movements.

Lafortune et al (1983) presented work using



intracortical pins to measure knee joint rotation, in particular patella and tibial motion with respect to the femoral reference plane. Steinmann pins driven into those parts were each associated with a target cluster. The clusters were located in anatomically fixed reference frames by photogrammetry. Sixteen millimeter cameras at 100Hz were used to track these target clusters during walking and running, information about patella movement in relation to the tibia and femur were collected. Quantified information has been documented using volunteer symptom-free subjects but the ethical problems associated with this type of work would prevent it being used extensively as a clinical tool. Patients with tibial or femoral fixators implanted may well be a source of interest but once again practicalities may preclude them from being used in this type of work.

A 3D x-ray technique (biplanar radiography) for accurate measurement of intervertebral movement has been reported by Percy et al (1983). This technique has been used clinically to assess surgical fusion and mechanical instability of the spine. Again the ethical problems of using x-radiation as part of an assessment technique would hamper it's use as a routine method for application to other parts of the body, in our case the lower limb. Van Dijk et al (1979) and Dimnet (1980) have all used methods of x-ray photogrammetry to

reconstitute the motion of joints and give precise description of the kinematics of in vivo joints in both planar and biplanar motion. Inaccurate pin-pointing of bony landmarks, too much movement between frames and inaccurate location of relative centres of rotation have all been observed in this technique and correction factors have been derived to reduce their effects on the end results.

Lippert et al (1978) stated that other than by surgical exploration there is no available method to detect early prosthetic joint loosening. They went on to describe a method of stereophotogrammetry of patella tracking patterns, used to measure the relative movement between implant and metallic markers, sited in bone near the prosthetic components. Their results yield displacements in the order of 1-2 mm which they suggest may be the order of magnitude around which pain becomes evident. They have implanted steel balls routinely in patients undergoing total hip and total knee replacement operations and their results promise to build up a data base of movement information and longitudinal records of individual joint loosening patterns.

The approaches described by Kemp, Lafortune, Pearcey, Van Dijk, Dimnet and Lippert allow the most direct quantification of joint and limb segment

kinematics so far described. However for ethical and practical reasons these radiographic and pinning techniques are not suited to routine clinical assessment. Methods of data reduction using film scanners and pattern recognition algorithms facilitate the automated analysis of information collected using photographic, cinematographic and soniometric devices. The real-time analysis of data by optoelectronic techniques e.g. VICON, SELSPOT and UNOPAR, is becoming an increasingly interesting area of study for the developers involved in human movement recording, clinical gait analysis being no exception.

It would seem then that there is a strong case for using an optoelectronic technique (as opposed to other imaging or direct measurement techniques), to quantify body movements as part of a gait analysis program. One such system has been shown to lend itself to several other fields of study apart from our own, which is an added bonus in a multidisciplinary department.

Summarising the advantages that these optoelectronic techniques are reported to have will allow us to assess the suitability of any chosen technique, whether it be one of those described earlier or a new technique. The list below is neither exhaustive, nor are the items in it in order of importance. However it outlines the benefits of

choosing an optoelectronic technique for the acquisition and analysis of human movement data, and in particular the benefits afforded by a newly developed system, CODA-3.

Real-time data availability and on-line analysis.

Minimal impairment of gait.

No distracting lights or loud apparatus noise.

With our new system no calibration is required.

Cartesian XYZ data format.

Speed of observed activity is not restricted by the limitations of the equipment.

Ambient lighting adequate for operation of the new system.

Data storage facility, for subsequent analysis.

Unskilled operators capable of running the system.

Note that the calibration of CODA was checked at intervals using a standard rule, for each of the three dimensions.

The techniques described so far were developed to

quantify knee joint loading and movement, with an underlying assumption that these will allow us to assess the functional capacity of the joint. Objective rating systems have been used at several centres, employing the above parameters, and others. The following section discusses several of these systems.

Aichroth et al (1978), explain the use of a chart to assess function of the knee joint before and after knee joint construction operations. It is a short questionnaire to be used by clinicians. Its aim is to assess the contribution made by other joints to the patients' disability, their level of pain, drug therapies, walking ability, range of joint motion and level of capability in a small number of everyday activities. The authors point out that the chart is not yet completely satisfactory and outline the need for standardisation functional assessment.

Collopy et al (1977), chose a number of objective measurements which were felt to be objective indicators of the degree of patient disability. The following kinesiological parameters were used to assess pre and post-operative total knee replacement patients over a one year period.

Range of active knee joint motion,

Extensor Lag,

Isometric strength of knee flexor and  
extensor muscles,  
Cane/Crutch force during walking,  
Velocity, cadence and stride length  
during walking,  
Weight distribution on standing  
(duration 1 minute),  
Forward, lateral and vertical pathways  
of the head for free speed walking  
Knee flexion/extension patterns through  
a walking cycle.

Post-operatively most of the patients showed an improvement in performance in the above tests, but were still below normal standards.

Chao et al (1980), carried out gait analysis on firstly normal then pre and post operative knee replacement subjects. Eight gait variables were picked out to be used in calculating an index of overall function (or performance) of the individual. The scale was a percentile score with a separation between normal and abnormal of around 50. A second index of symmetry with a value of 1.0, as an indicator of weight being equally distributed between left and right sides. These indices were used to assess the compensatory action of the normal side, and the derived functional improvement index, to indicate the difference in joint

condition pre and post-operatively. Table 7 shows a comparison of performance index (I), for different patient subgroups where  $I(D)$  is the functional improvement index, calculated as the difference in (I) pre and post-operatively.

COMPARISON OF PERFORMANCE INDEX AMONG DIFFERENT  
PATIENT SUBGROUPS.

Patient Group	Preop. (I)	Postop. (I)	I (D)
DJD	24.0 +/- 16.0	35.0 +/- 12.8	10.9
RA	25.8 +/- 20.8	42.6 +/- 13.1	16.8
Unilateral	23.7 +/- 13.4	36.9 +/- 9.8	13.2
Bilateral	26.0 +/- 20.9	37.8 +/- 15.7	11.8
UC	27.3 +/- 18.6	38.0 +/- 11.9	10.7
SC	24.2 +/- 18.6	37.3 +/- 14.7	13.1
C	18.3 +/- 10.9	39.7 +/- 6.6	21.4

DJD Degenerative joint disease  
RA Rheumatoid Arthritis  
UC Unconstrained  
SC Semiconstrained  
C Constrained

Table 7



The authors highlight that this functional performance index is only intended to allow an overall comparison of patient subgroups, and that for a comprehensive assessment of an individual patient, a complete set of gait variables should be available. However this method has proved to be a useful way of statistically manipulating the data to give a comprehensible "final score" representing the patients functional capabilities.

Tew et al (1981), like Chao, have devised an objective rating system which yields information relating to the functional capacity of the knee joint. Measures of pain and function are recorded on a scale of 1-5. The scores are acquired through a questionnaire administered by non-clinical staff at an out-patients clinic. Questions on pain are accompanied by questions referring to the patients drug therapy, state of his active arthritis, his general health and present mood. These were felt by the authors to be factors which played a part in his experience of pain.

Tests, devised to measure functional ability of the diseased joint before and after operation to replace the joint, were carried out under standardised conditions. These tests were constructed to isolate the contribution that the diseased knee makes to mobility before and after operation. Factors such as

stiffness, weakness, instability and incompetence of other joints were taken into account when scoring the patient on each of the activities.

Below are a list of the functional tests used along with a list of clinical parameters which are collected at the same time as questionnaire administration. This protocol is presently being used in Nottingham, providing a set of data on the functional ability of knee replacement patients, along with clinical findings. Its format allows for easy comparison of results, for each test between visits, and highlights the contribution to functional disability of the replaced knee joint.

Ability to walk,

Use of walking aids,

Ability to sit down and rise up,

Ability to use stairs,

Ability to stand,

Ability to stoop by bending the knees

Ability to kneel.

Coronal tibio-femoral angle,

Flexion/extension angles,

Hip abduction,

Presence of rigid valgus foot.

There are a large number of data processing techniques including sampling theorem and methods of filtering now in use. These methods of smoothing data are applicable in a variety of situations, but their particular application in our chosen data capture system will be discussed in more detail in subsequent chapters. For details of data processing in biomechanical research, Winter (1979) proved to be a very useful text.

FORMULATION OF THE PROBLEM.

## FORMULATION OF THE PROBLEM.

From the preceding discussion in Chapters I and II it has been suggested that to understand more about the mechanics and hence pathomechanics of the knee joint (and ultimately the whole body) we need a source of accurate information about the movements of the limb segments comprising a joint. The clinician already has a battery of tests which allow him to identify certain weaknesses within the joint and qualitatively measure these, but we need to quantify these movements. We must also be sure of which parameters are going to be of use to the clinician in helping him make prognoses and assessments of the effectiveness of treatments.

It has been seen that knee angle/time plots, Grieve diagrams and other forms of presentation of analysed data are of use clinically in characterising pathologies and the effectiveness of treatments. (Grieve 1969, Winter et al 1972, Mitchelson 1977 and Arnell et al 1982.) The primary objective therefore, is to investigate whether the very precise measurement of gait can be used to identify the changes which arise in a joint, quantitatively and reliably. Hence the first task is to echo the tests which produce the above mentioned results with the hope of reproducing them.

In addition to the above variables we will extend

the technique to look at variables which we feel might be magnified by the dynamic nature of the tests. Two hypotheses are put forward regarding the behaviour of the knee joint and they will be tested experimentally on a selection of patients.

#### First Hypothesis.

It has been hypothesised that changes in linear acceleration of landmarks mounted around the knee joint might be elicited by joint loading or change of sense of direction of forces - seen at heel strike or during single support (see definitions of these terms in the Introduction). Therefore at points in the gait cycle of maximum joint loading it is suggested that weaknesses in a prosthesis are likely to be highlighted by examining this variable.

#### Second Hypothesis

A second hypothesis is that by looking at the difference in acceleration of two markers placed directly above and below the knee joint one would see a smooth waveform in the normally functioning knee but in a biomechanically unsound knee ie. one with mediolateral or anteroposterior instability, one would see a breakdown of this smooth pattern when the slip/jerk movement occurs.

Should either of these two hypotheses be accepted

then it would follow that from the serial dynamic responses during gait, changes in the condition of replacement joints and Ligament or meniscal damaged joints may be identified.

Firstly however it was decided to tackle the problems of non-coincidence of skin markers with bony landmarks and quantification of landmark movements other than the positional movement being measured. With all movement monitoring systems employing surface markers, (that is where pieces of the equipment are attached to the subject/patient using strapping or sticky tape), errors exist within the collected data these are due to:-

1. Inaccurate location of the markers relative to bony landmarks,
2. Poor fixation of the markers,
3. The movement of soft tissue underlying the marker relative to bone.

Few workers have acknowledged these sources of errors, so by a radiographic technique an attempt at quantification of these errors was made. Prior to this, however, methods of landmark fixation were

investigated, combining strapping, taping and plating, to find the most suitable combination.

Fourteen by fourteen millimeter anodised aluminium bases, supporting the retroreflective prisms, were taped and/or strapped to the lower limb. So as not to cause too much discomfort the tightness of the Velcro (R) strapping used allowed some movement of the marker. With the additional security offered by using double sided tape, it was anticipated that the markers would not move over the skin. Soft tissue is composed of the elements listed below and the extent of their effect on marker movement relative to bone will be dependent on the proportions of these.

1. Skin
2. Fascia—deep and superficial
3. Muscle
4. Tendon
5. Ligaments
6. Retinacula
7. Bursae
8. Adipose Tissue

To arrive at some broad conclusions regarding marker movement over the skin and relative to underlying bone during knee flexion/ extension exercises, the movement of dummy markers strapped to



the lower limb were recorded. Extension of the conclusions from this work to the dynamic situation ie. during gait was investigated.

It is also necessary to test the reliability of the output of the chosen recording device, after which the software developed for capture and analysis of the collected data must be validated. This analysis will provide parameters which are relevant to the compilation of a definition of joint condition, and will be decided from a series of pilot studies.

EQUIPMENT.

## EQUIPMENT.

### Introduction.

The equipment used in this study is housed in the Gait Laboratory in the Department of Orthopaedic and Accident Surgery, University of Nottingham Medical School, within the University Hospital. The Laboratory occupies an area of 112 sq.m. giving a walkway of approximately 12 m. The width of the laboratory had to allow for the minimum operating distance needed by the CODA-3 scanner unit and the polarised light sonometer.

The force plate is embedded in the middle of the walkway. Although we are primarily interested in the stance phase of gait, (ie. during contact with the plate) it was decided after carrying out several testing sessions, with subjects who were naive of gait analysis methods, that extension of at least 4 m. in both directions beyond the force plate was desirable. The CODA-3 scanner unit and peripherals are sited as shown in the laboratory layout Figure 7. This layout, designed by the author, gives optimum operating distance for the scanner unit, as mentioned above and also allows for the interfacing necessary between CODA-3 and the laboratory computer. (See figure 8). The computer is positioned to give discrete viewing of the patients' walking activities without interference, at

Figure 7 Gait Laboratory Layout

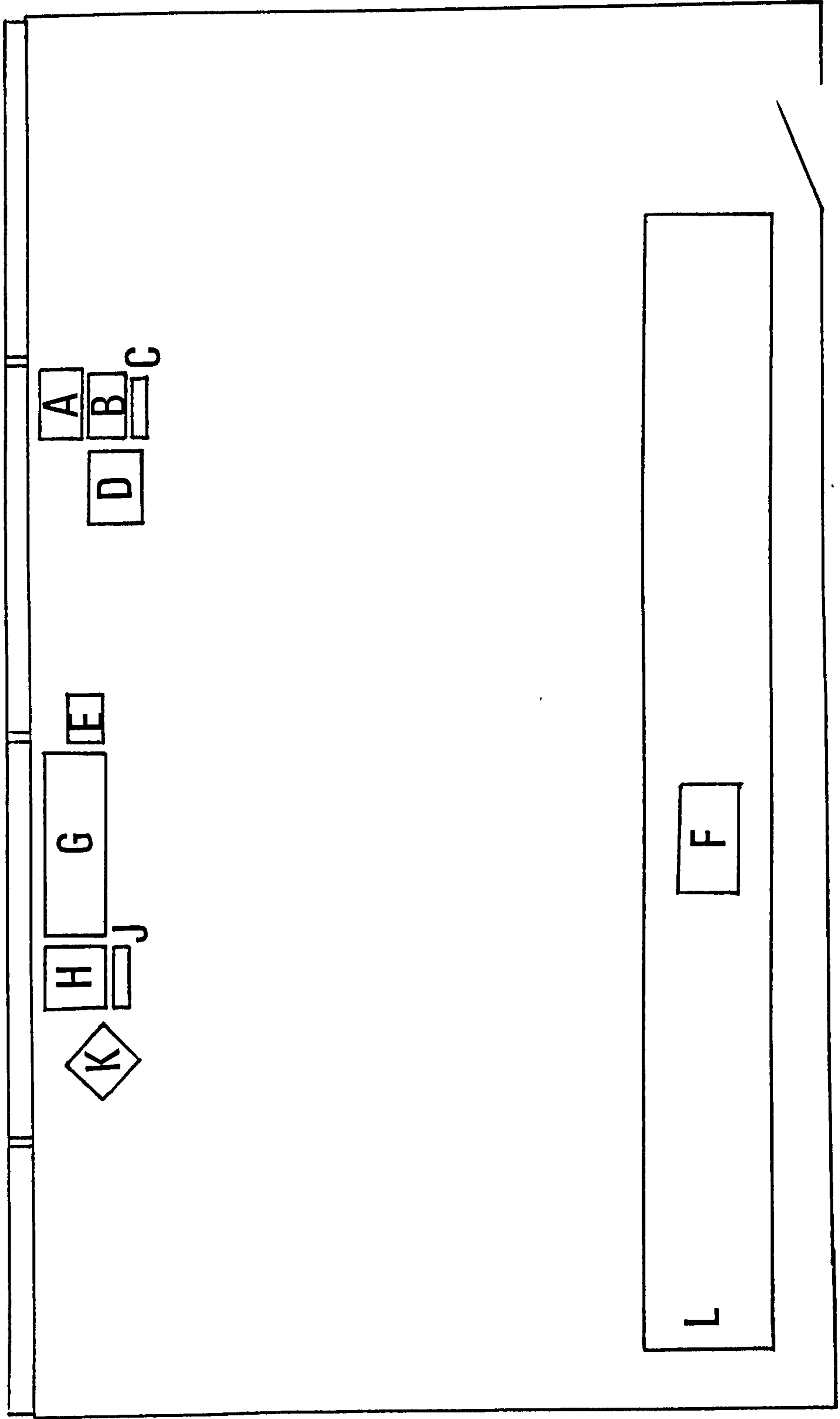

Key to Laboratory Layout.

- A - Hitachi Denshi Video Monitor
- B - Digital Equipment Corporation (DEC)  
VT-100 Visual Display Unit (VDU)
- C - VT-100 keyboard
- D - DEC RX02 twin disc drive
- E - Kistler Force Plate Amplifiers
- F - Kistler Force Plate
- G - CODA-3 scanner unit
- H - Shelton Signet microprocessor
- J - Shelton keyboard
- K - Shelton VDU
- L - Walkway.

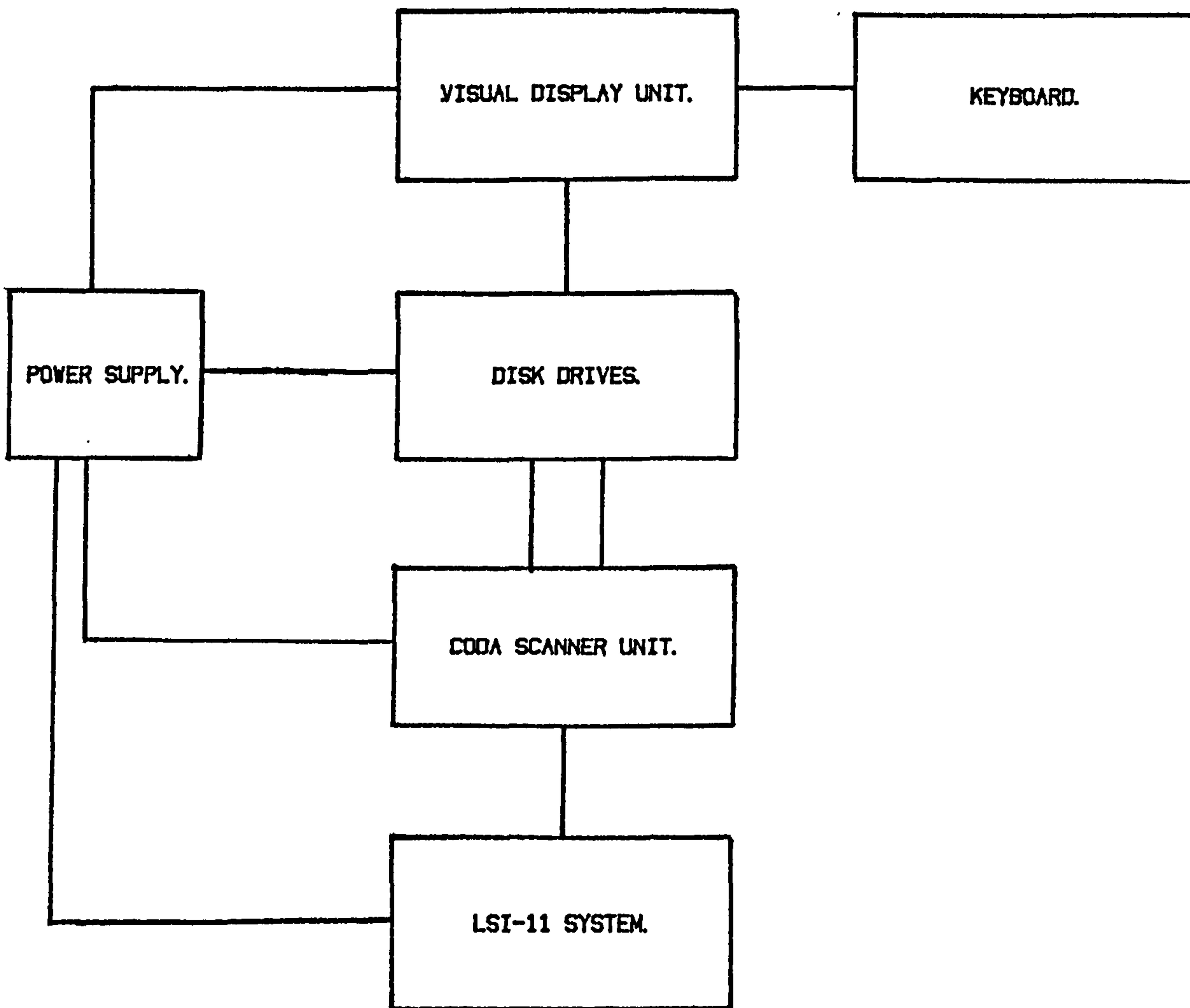

Figure 8 CODA-3 Interfacing

the same time giving a layout which facilitates easy access to the peripherals and avoidance of glare.

Digitised CODA-3 data is transferred by ribbon cable to our LSI-11 microprocessor and can be analysed immediately or stored for later recall. (For details of software see later.) Listed below are the pieces of equipment used followed by a more detailed account of their design and function.

1. CODA-3 Scanner unit (Movement Techniques Ltd.)
2. Shelton Signet microprocessor with visual display unit and keyboard
3. Interface between CODA-3 and LSI-11
4. Digital Equipment Corporation MINC LSI-11/2 processor
5. Hard Copy Unit (Tektronix 4632)
6. Hitachi Denshi Video Monitor (VM-172AK)
7. Kistler Biomechanics Platform (Type 9261A)
8. Kistler Charge Amplifiers (Type 5041)

#### CODA-3 Scanner Unit (See Plate 1)

The scanner unit produces three fan shaped beams of white light which are swept across the field of view by three mirrors. The prisms, (see Plate 2) which are differentiated by colour, reflect brief pulses of light back along the emitting path, these then being detected



PLATE 1 The CODA-3 Scanner Unit





Plate

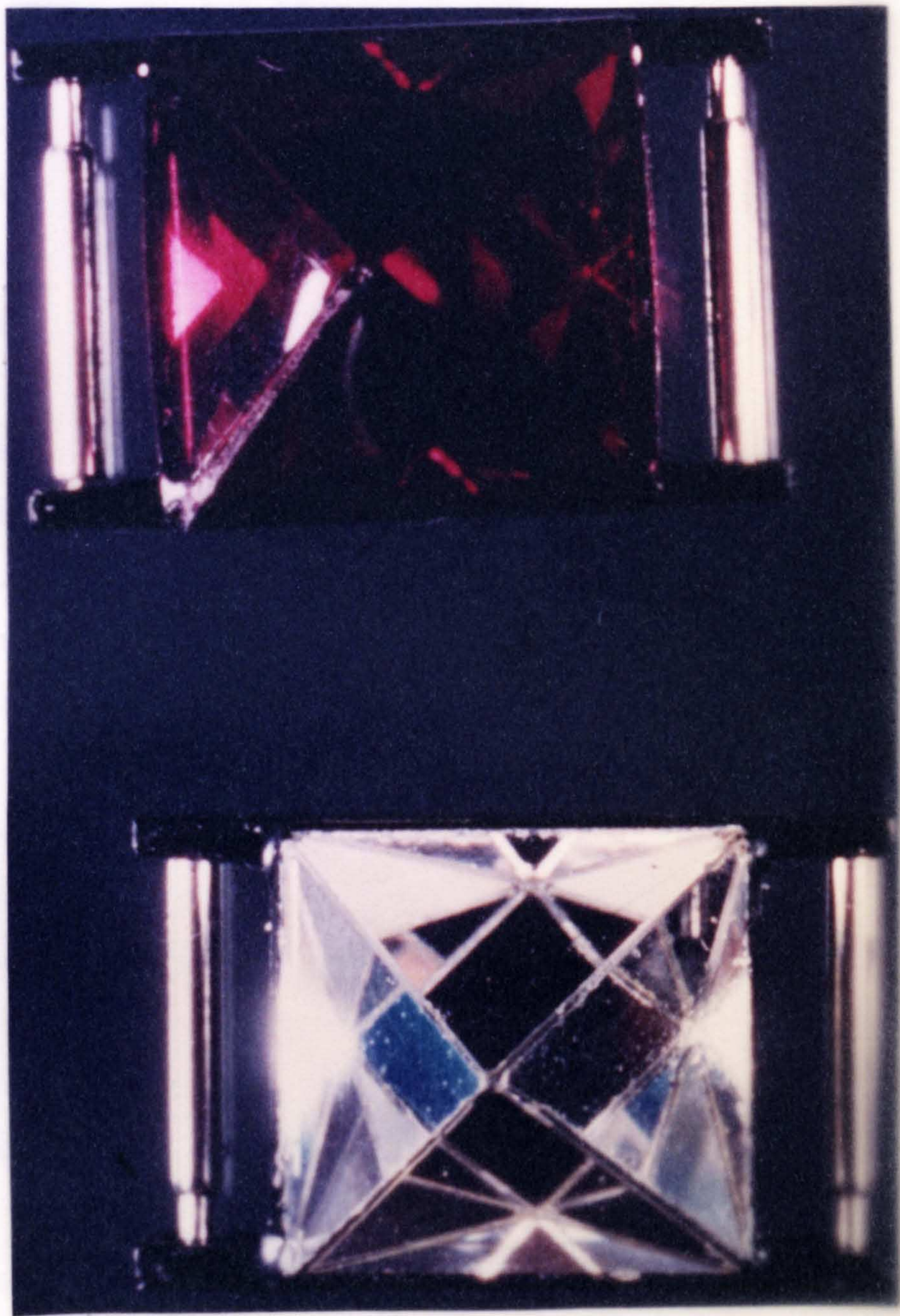
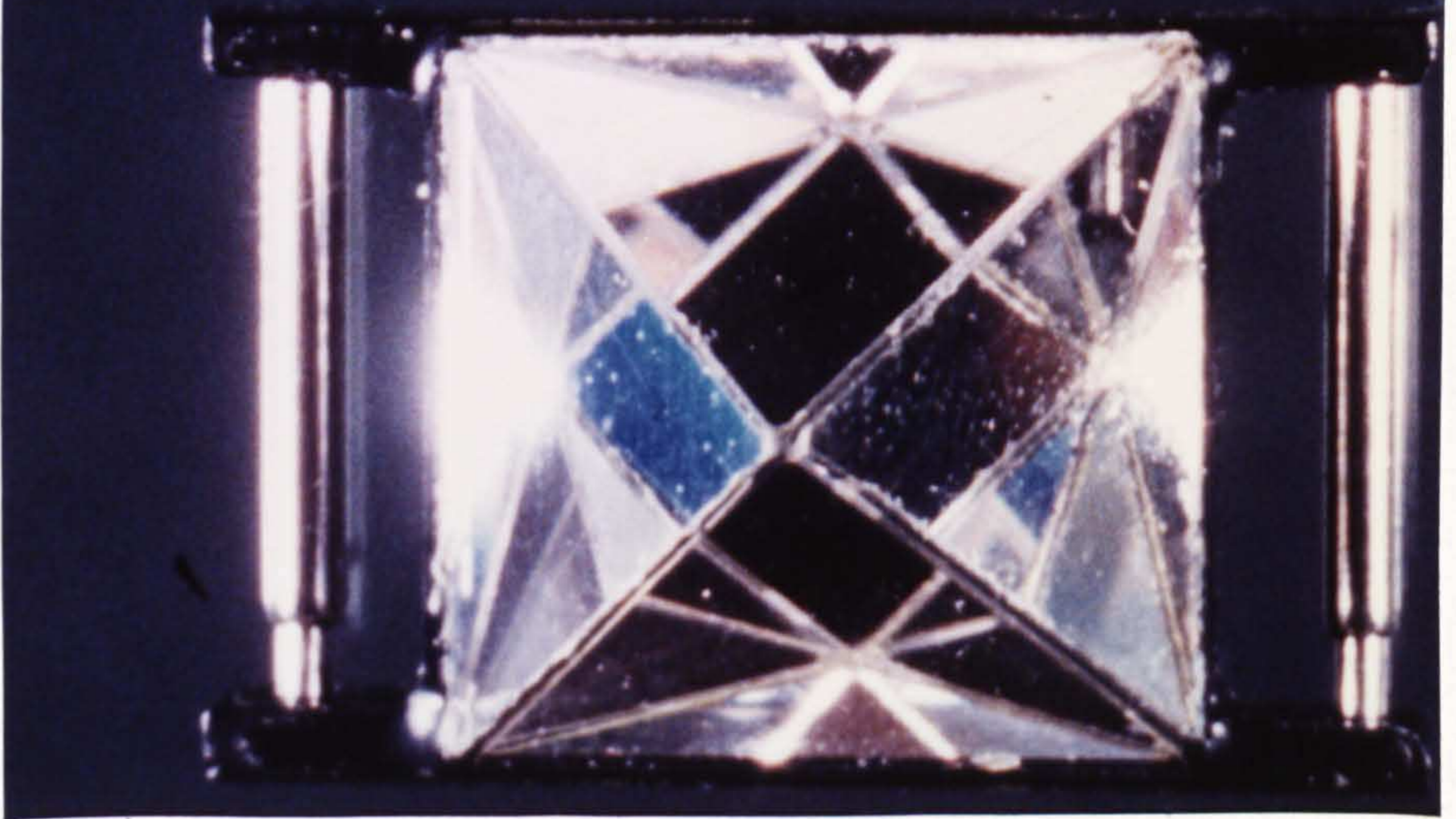
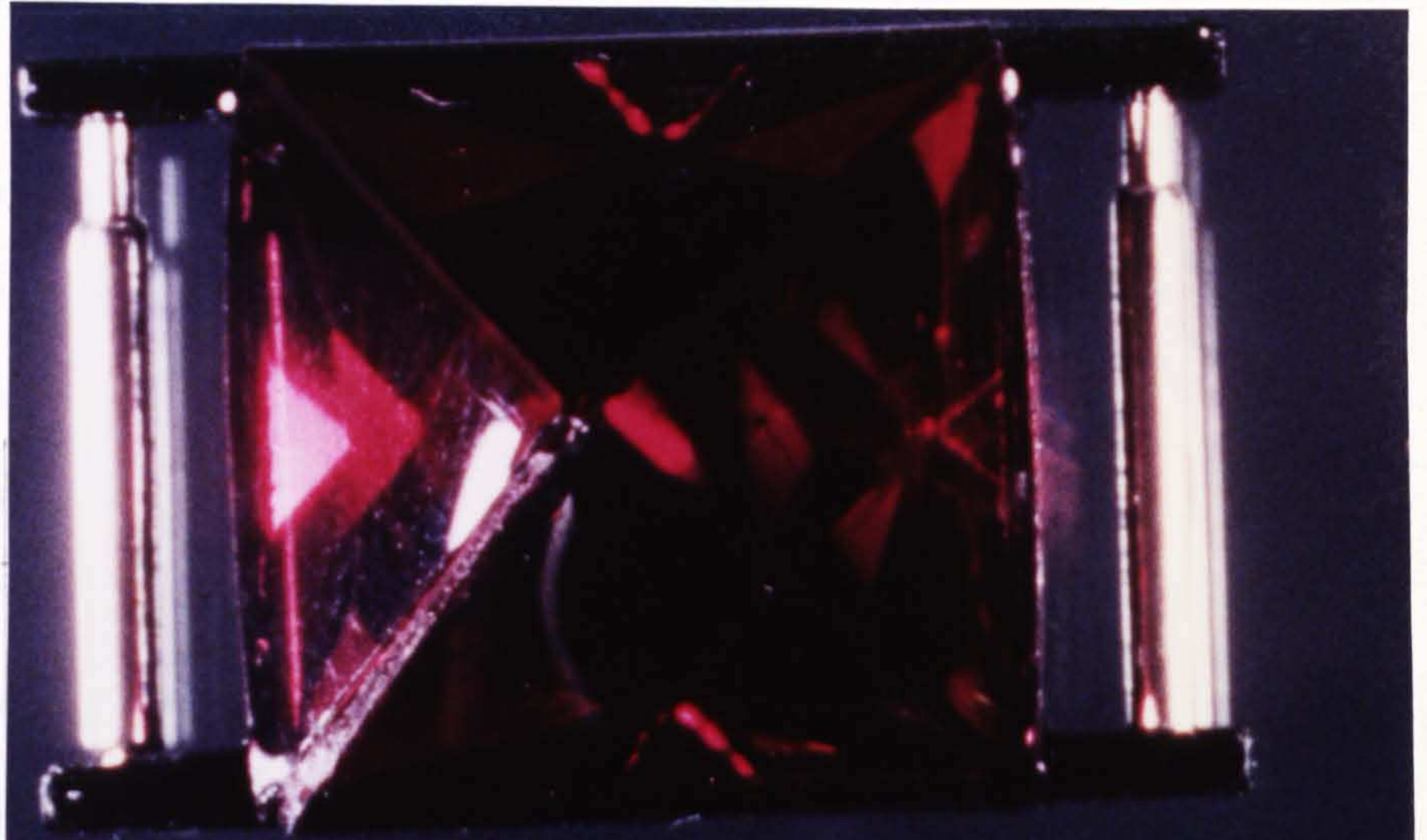

PLATE 2 The CODA-3 Prisms



by photodiodes in the scanner unit. As the light has to be incident on the base of the prism the prisms themselves must be angled so as to receive the incident light, which allows for around 45 degrees of inclination of the base to the horizontal. A position measurement, calculated from the phase of the returning pulse in relation to the mirror rotation, is converted into a time measurement. A master clock (a crystal controlled oscillator) provides the time reference for the light pulses and the speed control circuitry of the scanner motors. The system is so designed that it has essentially zero drift.

Three scanning drums, two mounted horizontally and one mounted vertically, provide signals which are used to triangulate for landmark distance, transverse horizontal co-ordinate and vertical position of the landmark. Four fast 16 bit microprocessors compute the true, parallax-free cartesian XYZ co-ordinates of the landmark within each time period. The output from CODA is available in both analogue and digital form.

(For fuller details of the circuitry used consult Movement Techniques Ltd.).

Shelton Sianet Microprocessor

The user interface is provided by the Shelton

Signet 2FS microprocessor, VDU and keyboard. The software allows the user to select one of three available displays. On booting the VDU provides a continuous update of the XYZ co-ordinates of the Landmarks along with an "in-view" marker (>) which tells the user which Landmarks are being "seen" by the scanner unit.

Starting up the CODA system entails two simple procedures. First, powering up the Xenon lamp ignition capacitors to fully charge (about 15 seconds), then striking the Xenon arc by the 20kv ignition pulse. This results in three beams of light being emitted from the front ports of the scanner unit. Secondly the systems disc is inserted in disc drive A and the two reset buttons, one on the scanner, and a second on the Shelton SIG/NET are depressed. To boot the Shelton the 'enter' key is depressed four times. The software is then loaded, after which the continuously updated XYZ co-ordinates with in-view markers are displayed on the VDU terminal.

As alternatives to this display, a page of text giving a brief description of the keyboard commands can be called up. This includes the commands for altering the scale factor of landmarks and defining new origins for the landmark co-ordinates (see below). Another command brings into effect the low pass filter

available in the software, useful when monitoring slow movements. CODA can be programmed through the Shelton user interface so that when designated points, lines or planes within the measurement volume are crossed by a particular landmark external equipment can be controlled in real time via 16 TTL compatible output latches. The third display shows a table of the imaginary "boxes" and the effect on the output latches when various landmarks move in or out of them.

There is no need for calibration other than by depressing the reset button as mentioned above. However the user can redefine the origin of the system, which on booting is located at the scanner unit. This is carried-out by placing any landmark (n) at the new origin (user specified), typing the appropriate command, after which the origin of the co-ordinates for the eight landmarks is set to the current position of landmark n. Landmark n is then free to be used in the same fashion as any of the others. On booting, the scale factor of the co-ordinates is set so that the finest resolution is 1/5 mm. This can be changed by the necessary input command to give resolutions of between 1/10 mm and 1mm.

Interface.

The digital output from CODA-3 is fed to the

Laboratory computer by two nine way shielded cables, through an interface box then via a ribbon cable to the interface board, purpose built for relay of the CODA data. Patching of the circuitry was carried out by the author under the guidance of an electronics technician. This served to familiarise her with the circuit layout and serve a useful purpose should the need for fault finding arise.

The Laboratory Computer (See plates 3 and 4).

The laboratory computer is a DEC MINC-11 with an LSI-11/2 microprocessor. It has 64KBytes of memory and twin disc drives (Digital Equipment Corporation RXD2, total storage capacity 1MByte). Eight inch floppy discs are used as the storage medium for the system and run programs, (for description of software see later). There is a built-in 16 channel analogue-to-digital converter (ADV11-A). A MATROX Electronics Systems graphics board (MLSI-512), using PLOT 512 software, facilitates the display of processed data on a Hitachi Denshi video monitor (VM 172AK). Hard copies from this, and the DEC VT100-AB VDU can be made using a Tektronix Video hard copy unit (Model 4632).

The digital signal from CODA-3, containing the XYZ co-ordinates of the eight landmarks and the in-view flag are fed direct to the computer. The six channels

PLATE 3 THE LABORATORY COMPUTER - DISC DRIVES





digital RX02



PLATE 4 THE LABORATORY COMPUTER VDU AND KEYBOARD



**WARNING**

**Digita VT100**

```

PLEASE -- Press return key
which landmark?
CBM acquisition and analysis of force plate data
Enter patients' details
1. Acquire data
2. Stoping run data (called reinitialization)
3. Starting run
4. Tibial rot.
5. Continuous sampling and graphic display
6. Line display of recorded data
7. Statistics between landmarks
8. Statistics from data
9. Recall from disc
10. Stop
11. Select landmarks for analysis
12. Type run CBM data
13. Type run force plate data
14. Type velocity
What next ? |

```

Figure 10

9.30"	9.30"	9.30"	9.30"
Line	Line	Line	Line
Level	Level	Level	Level
9.30"	9.30"	9.30"	9.30"
Line	Line	Line	Line
Level	Level	Level	Level
9.30"	9.30"	9.30"	9.30"
Line	Line	Line	Line
Level	Level	Level	Level
9.30"	9.30"	9.30"	9.30"
Line	Line	Line	Line
Level	Level	Level	Level

File name: CBM

from the force plate, which are in the range  $\pm 2.5$  volts, are put through charge amplifiers (Type 5041) then fed to the A/D converter.

#### Force Platform.

The Kistler biomechanics platform (Type 9261A) is a piezoelectric transducer, composed of four three-component quartz transducers. Each transducer measures three components, XY and Z. Together they measure the three applied forces and their respective moments giving the location of the point of application of the force. The plate has the dimensions 400x600x60 mm, the four transducers being separated by 264 mm across the width and 440 mm along the length of the plate. The plate is embedded to manufacturers standards and calibrated as suggested in their manual (Kistler 1977).

#### Software

The programs for data acquisition and analysis have been written by two members of Orthopaedic Department staff, the author being one of them. The aim throughout was to display all results in an uncomplicated comprehensible format. The whole run procedure had to be user friendly as those naive to computing would be expected to operate the system at a

later date. All subroutines were written in FORTRAN IV using the TECO editing system available on the laboratory computer.

Flowcharts and source listings for the subroutines can be found in Appendices A and B respectively. Also in Appendix B is the theory behind the calculation of velocity, acceleration and angle data, used in the FORTRAN software. The main acquisition and analysis programmes were written to run on the Sait Laboratory computer. Another set of subroutines was written to analyse the data and produce hard copies of the results using a Hewlett Packard plotter on-line to a MINC-11 computer in the Department's computer laboratory.

The software allows for real-time or delayed data analysis, using the facility to store CODA and force plate data on floppy disc. The analysis consists of a set of calculations carried-out on the data, as well as a variety of data display formats. These include raw data information (in the form of 24 CODA and 7 force plate plots), line displays of recorded data in any one of the three dimensions and a continuous real-time update of the position of any number of prisms as a display on the TV screen. A second horizontal axis seen on many of the traces is derived from the in-view flag from CODA and when present on the displacement plots indicates that that prism is in view. On all

other plots presence of the line indicates that that prism is out of view.

The options which are available to the operator are displayed on the VDU in the form of a menu of items prefixed with a number (see fig 9). Choice of a particular item from the menu is then made by referencing the appropriate number. After completion of each procedure the system returns to the menu display mode and the user can again make his choice.

Figure 9 CODA-3 Menu

**CODA acquisition and analysis. H Harvey, J Towle October 1983**

1. Enter patients' details
2. Acquire data
3. Display raw data (called automatically)
4. Define axes
5. Tibial rot.
6. Continuous sampling and graphic display
7. Line display of recorded data
8. Distance between landmarks
9. Recall from disc
10. Stop
11. Select landmarks for analysis
12. Type raw CODA data
13. Type raw force plate data
14. Type velocities

What next ? ■

METHODS.



# EVALUATION OF METHODS

## INTRODUCTION

### 1.0 Landmark Fixation Techniques

#### 1.1 Method

#### 1.2 Results

#### 1.3 Inferences

### 2.0 Landmark Location and Movement

#### 2.1 Method

#### 2.2 Results

#### 2.3 Inferences

### 3.0 CODA-3 Output Reliability

#### 3.1 Static Tests

##### 3.1.1 Methods

##### 3.1.2 Results

##### 3.1.3 Inferences

#### 3.2 Dynamic Tests

##### 3.2.1 Methods

##### 3.2.2 Results

##### 3.2.3 Inferences

### 3.3 Data Capture on Laboratory Computer

#### 3.3.1 Method

3.3.2 Results

3.3.3 Inferences

## EVALUATION OF METHODS.

### Introduction

This chapter details the sequence of experiments which were devised to test, step by step, the equipment which was to be used. The description of each test covers the four points below plus any other details specific to that particular experiment.

1. Aim of the experiment
2. Formulation of test procedure
4. Results and analyses
5. Inferences.

As CODA-3 is a novel data capture device, the results it gives cannot for the most part be compared with those of other systems, but where possible this has been done.

One of the first problems was that of landmark fixation and movement. Experiments 1 and 2 detailed below were devised to investigate these problems. This

is an area which it was felt had been inadequately covered by many workers. The reliability of CODA output was tested as described in Experiment 3. As a result of these experiments an alternative method of mounting the markers was investigated and is described in the next chapter.

## 1.0 Landmark Fixation Techniques.

As mentioned earlier, the prisms used as landmarks by the CODA-3 system are mounted on a base of anodised aluminium (see plate 2). When clean this surface has a matt finish which, the manufacturers have suggested would provide a suitable surface for attachment by sticky tape. The tape was required to provide a firm adhesion to the anatomical landmark without causing discomfort on removal. The possibility of initiating an allergic reaction was another consideration, so several of the tapes on the market (ie. those that had not been used on skin before) were excluded from the test.

### 1.1 Method

In order to evaluate the effectiveness of the variety of sticky tapes available a simple procedure was adopted. During a fixed number of trials(3), the

marker, with the tape under test in place, was attached to the author's lower limb at a selection of sites which it was anticipated would be used at a later date (see plate 5). The outline of the base of the landmark was drawn onto the skin with clinical marker pen. The author then carried out her usual activities, with the marker attached, for approximately half an hour. After this time the displacement of the base in relation to its initial position was noted. This was repeated for each site and for each type of tape. Where practical a combination of Velcro (R) band and sticky tape was put under test in the same fashion.

## 1.2 Results

It was evident that one variety of tape fulfilled the requirements much better than any of the others. Fractional movement of the base of the prism on the sticky tape occurred for all sites. This movement was too small to give concern compared with movements of the tape over the skin which were in the order of millimeters for several of the other tapes. Masking tape provided a very good hold but proved too difficult to remove after a period of half an hour, which is the amount of time the landmarks would be in place during a typical test session.

## 1.3 Inferences

It became obvious from this study that care would have to be taken when using strapping around the leg. Although initially fairly comfortable, after several minutes of exercise the band soon tightened up due to increased leg volume. If this were allowed to happen during a test session then the advantages of having an unobtrusive system without an umbilicus would be negated.

Once a tape had been decided upon the accuracy with which the landmarks could be sited on the body was tested, and secondly the extent of their movement over the skin quantified.

## 2.0 Landmark Location and Movement.

If the CODA system was to be used optimally then those using it should be capable of accurately placing the systems landmarks on/over anatomical points. It was imperative that the author familiarise herself with surface anatomy. Colleagues allowed her access to their patients and were prepared to act as tutors to help her acquire the skill of bony palpation.

A test of the ability of the experimenter to locate accurately a prism on a palpable bony landmark was heavily scrutinised by the author's clinical

supervisor (Professor W. Waugh). The following palpable landmarks were used:-

Lateral malleolus

Head of fibula

Tibial tubercle

Medial and lateral tibial plateaus

Patella

Medial and lateral femoral epicondyles

Greater trochanter of the femur

Anterior superior iliac spine.

Further to this the above palpable landmarks were used to obtain an approximation of the long axes of the femur and tibia and the approximate location of the centres of rotation of knee and ankle joints.

A study of the literature revealed only one paper which attempted to quantify the movement of surface

markers over the skin (Townsend et al 1977). They used elastic Velcro (R) strapping and rod-connected curved plates to increase contact area, and using radiographic measurements, quoted movements of these attachments relative to the underlying bone of 1/8th " (3mm). However, no details of direction of movement were given, ie. whether it was inferiorly/superiorly or rotationally about the respective long bones. Presuming this to be a consistent error inherent within the attachments, Townsend et al assumed the movement to be sufficiently small to ignore and to allow collection of comparable results.

It was thought appropriate, that as routine diagnostic X-rays are taken at a knee clinic held by an Orthopaedic Surgeon who headed the said laboratory, an X-ray analysis of landmark movement would be used. A system used at the clinic to assess the alignment of the lower limb segments, ie. varus/valgus and the knee's range of movement, ie. flexion/extension, entails use of anatomical landmarks to line-up the goniometer (with extendable arms), over the femoral and tibial shafts. The author was allowed to place a marker in mid-shaft of the tibia and femur on the lateral aspect of the leg, and from x-ray films taken of the limb, quantify the landmark movement which had taken place during knee flexion. The site of marker placement had to be chosen such that it did not



interfere with the clinician's assessment. The author is aware that at these sites landmark movement may well be different from that at more bony sites eg. head of fibula or tibial tubercle. For ethical reasons the author could not justify taking extra X-rays, to allow placement over all points of interest, so extrapolation from the points taken will be made.

Analysis of marker movement and location was carried out using mock markers composed of the authentic bases used by CODA-3, replacing the prisms with a cube of perspex in which were embedded two sets of radio-opaque cross-wires, (one set lying above the other). The cross-wire configuration allowed assessment of the orientation of the cube. Quantification of the distance of the base pair of wires from a recognisable reference point, eg. bony prominence or part of a prosthesis, allowed analysis of the marker's movement relative to the bone, in a known direction.

The major drawback of this technique is that it relies upon the patient performing flexion/extension movements of the knee to yield two sets of relative positional data for the markers. In this type of movement there is an unknown component of tibial and femoral rotation which introduces unknown errors into the data points. Even patients with hinge joint

prostheses could not be assumed to yield data without this rotational component.

## 2.1 Method.

Thirty four patients whose knees were X-rayed for clinical purposes had the estimated position of the mid-shaft of both tibia and femur marked on their skin. At this stage the markers, mounted on Velcro (R) straps and with adherent tape, were put onto the patient and tightened within the limits of patient comfort. From the clinic the patients walked or took the lift down two floors to the X-ray department. The position of the markers was then checked before any pictures were taken. Radiographs of the knee with markers in place were obtained in extension and approximately 60 degrees of flexion, from the lateral aspect. After making sure that satisfactory films had been acquired the markers were removed and the patient was allowed to leave.

Analysis of the results took place over a light box which allowed clearer visualisation of the films. The same reference points on each of the extension and flexion films were checked for adequate clarity. Pencil lines drawn onto the films (see fig 10 ) were measured to obtain the distance of each marker from the reference points and from the periosteum (the pencil line having been drawn at right angles to the

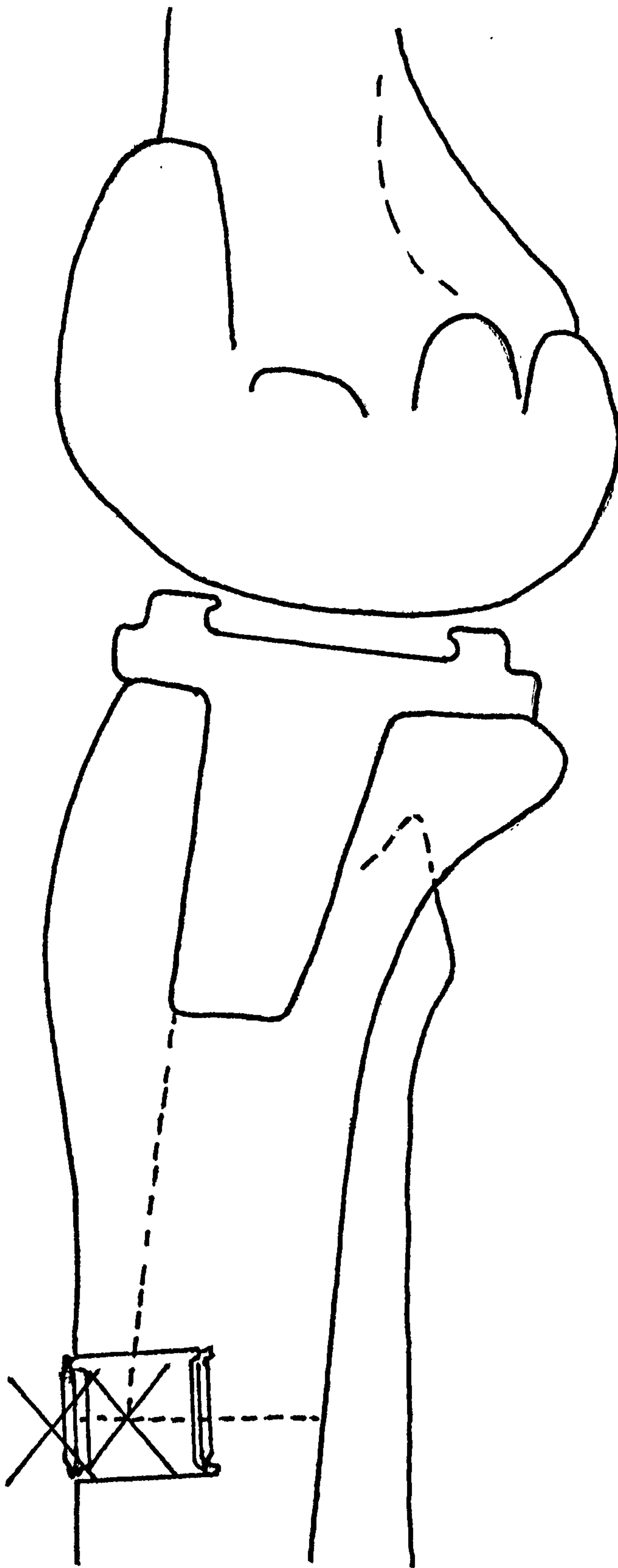

Figure 10 Tracing of a radiograph with pencil construction lines drawn onto it.

periosteum). Repeat measures were taken for completeness. A simple calculation yielded the amount of movement of the markers in two directions.

Orientation of the markers was determined in a similar manner using simple trigonometry. However it was realised later that if the landmarks moved over the skin the orientation of the cross-wires would become meaningless and this idea was abandoned.

The anterior/posterior (x) and inferior/superior (y) movements of the landmarks were averaged for all the knees grouped together (ie. irrespective of type). The corresponding standard deviations and standard errors were calculated. The same procedure was repeated, but with the results sub-grouped, as can be seen from the results in Table 8, the idea being that different degrees of long axis rotation were allowed by the three sub-groups and that by grouping them thus, differences in the extent of marker movement might be seen (ie. does the constrained type prosthesis result in more or less marker movement than the semi-constrained).

In order to assess how accurately the landmarks were placed over the mid-shaft of the tibia and femur, correlation coefficients of bone width at the level of marker placement and distance of the landmark to

SUB-GROUPED RESULTS FOR LANDMARK MOVEMENT

Knee Type	Limb Segment	No.	X	Y	S.D.		S.E.	
					X	Y	X	Y
Natural	Femur	8	4.62	2.17	3.49	6.94	1.23	2.45
	Tibia	11	7.58	-2.24	5.39	3.63	1.62	1.01
Constd.	Femur	7	5.94	5.04	6.71	8.25	2.54	3.12
	Tibia	7	7.56	-4.21	7.03	8.16	2.66	3.09
Semi/Un	Femur	17	3.8	1.07	4.10	6.05	0.99	1.47
	Tibia	16	5.37	-2.05	5.21	6.14	1.30	1.53

Key

X Average horizontal displacement

Y " vertical " (negative inferior direction).

S.D. Standard deviation

S.E. Standard error

Constd. Constrained eg. Walldius, Kinematic

Semi/Un Semi or unconstrained eg. Freeman, Sheehan, Oxford.

(Although the Oxford has been included in this last group it is appreciated by the author that it is usually classed as a compartmental prosthesis, and this classification was only employed because of our very small numbers).

Table 8

mid-shaft of the bone were calculated. The femur and tibia were dealt with separately, but no attempt was made to use the sub-groups devised earlier.

## 2.2 Results and Analysis.

The results are presented in two forms. Table 9 shows the means and standard deviations taking into account the direction of landmark movement, and table 10 which takes no account of direction of movement but quantifies only the average amount of displacement. (Where a negative value is seen this indicates that the landmark has moved in an inferior direction.) The high standard deviations seen here and in Table 8 highlight the large spread of the results, reasons for which are suggested below. A breakdown of knee types is given in table 11. Table 12 shows the percentage of each replacement type that exhibited a landmark displacement above the average for all knees. Table 13 similarly shows this parameter but as a percentage of knees within each knee type. The average amount of knee flexion was 57 degrees with a standard deviation of 11 degrees. Fig 11 and 14 show plots of landmark movement in the x and y directions against the degree of knee flexion, as measured from x ray film, for each patient. The low correlations between these two would suggest a poor relationship between these two variables. (See table 14)

LANDMARK DISPLACEMENT TAKING INTO ACCOUNT  
THE DIRECTION OF MOVEMENT.

Knee Type	Limb Segment	No.	X	Y	S.D.		S.E.	
					X	Y	X	Y
ALL Knees	Femur	32	4.41	1.13	4.57	7.0	0.81	1.24
	Tibia	35	6.47	-2.37	5.54	5.85	0.94	0.99

Table 9

LANDMARK DISPLACEMENT TAKING NO ACCOUNT OF  
DIRECTION OF MOVEMENT

Knee Type	Limb Segment	No.	X	Y	S.D.		S.E.	
					X	Y	X	Y
ALL Knees	Femur	32	4.47	5.8	4.57	3.97	0.81	0.70
	Tibia	35	6.47	5.07	5.54	3.68	0.94	0.62

Table 10

Key

X Average horizontal displacement  
 Y " vertical " (negative inferior direction).  
 S.D. Standard deviation

BREAKDOWN OF KNEE TYPES WITHIN THE STUDY.

(as a percentage of all knee types).

Femur:-

Constrained	Un/Semiconstrained	Natural
22 (7)	53 (17)	25 (8)

Tibia:-

21 (7)	47 (16)	32 (11)
--------	---------	---------

(Actual numbers in brackets)  
Figures rounded up.

Table 11



PERCENTAGE OF EACH REPLACEMENT TYPE WHICH  
EXHIBITED ABOVE AVERAGE DISPLACEMENT.

Femur:-

Constrained	Un/Semiconstrained	Natural
16 (5)	16 (5)	9 (3)

Tibia:-

21 (7)	21 (7)	6 (2)
--------	--------	-------

(Actual numbers in brackets)  
Figures rounded up.

Table 12

PERCENTAGE OF KNEES WITHIN EACH KNEE TYPE WHICH  
EXHIBITED ABOVE AVERAGE DISPLACEMENT.

Femur:-

Constrained	Un/Semiconstrained	Natural
71 (7)	29 (5)	37 (3)

Tibia:-

100 (7)	41 (7)	18 (2)
---------	--------	--------

(Actual numbers in brackets)  
Figures rounded up.

Table 13

against degree of knee flexion†

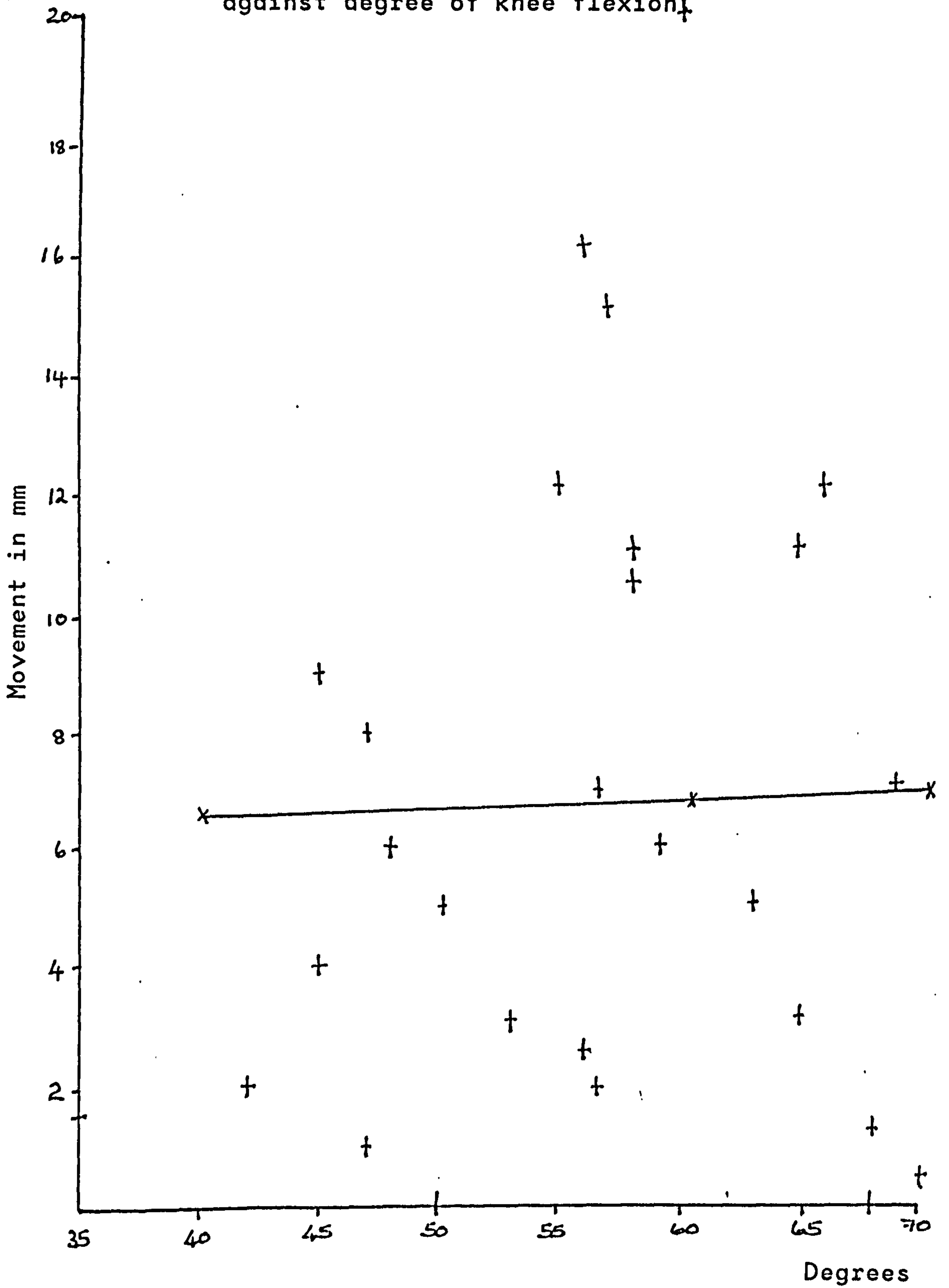

Figure 11

against degree of knee flexion.

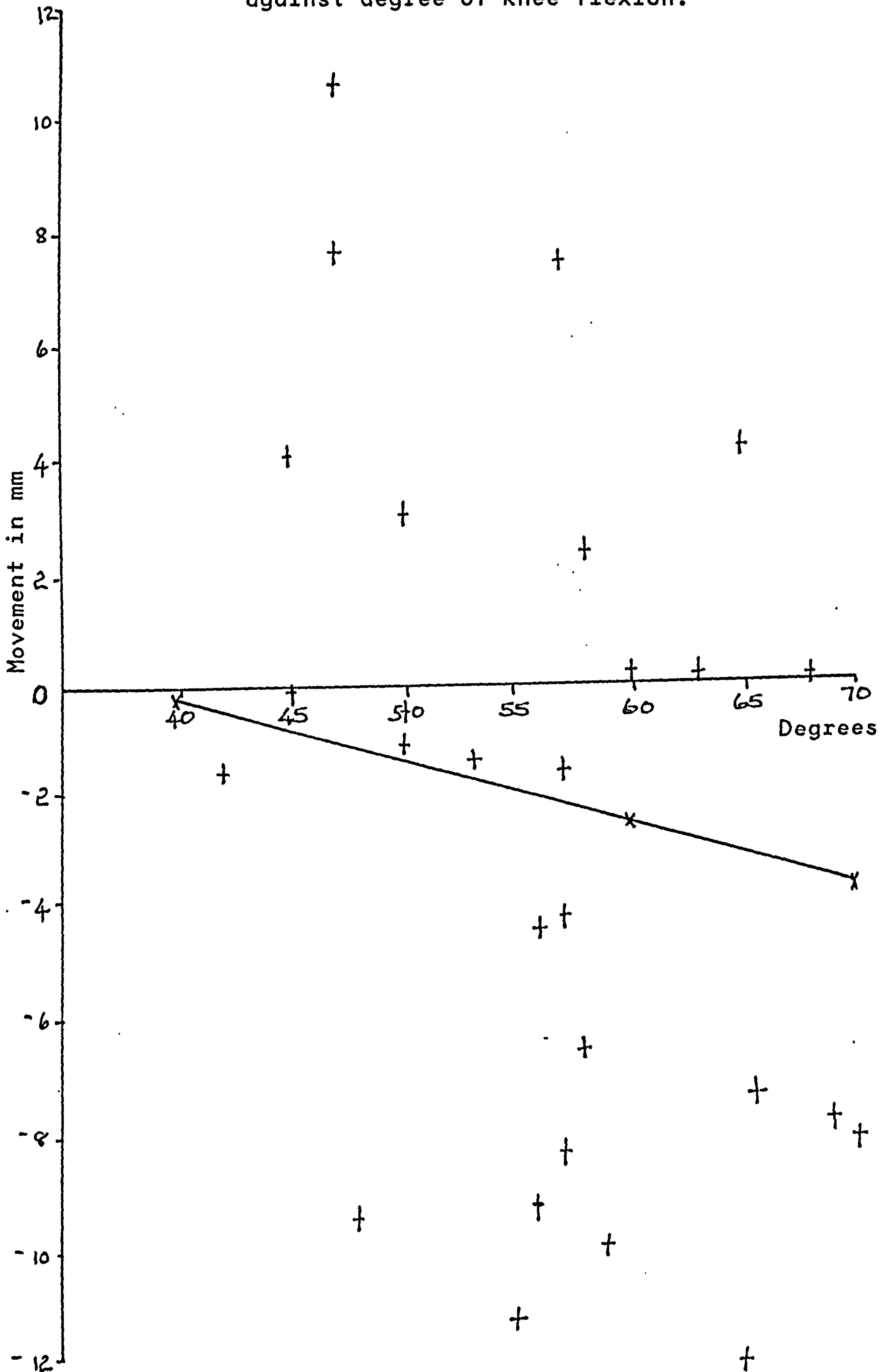

Figure 12

Movement of landmark in the x-direction on the femur  
against degree of knee flexion.

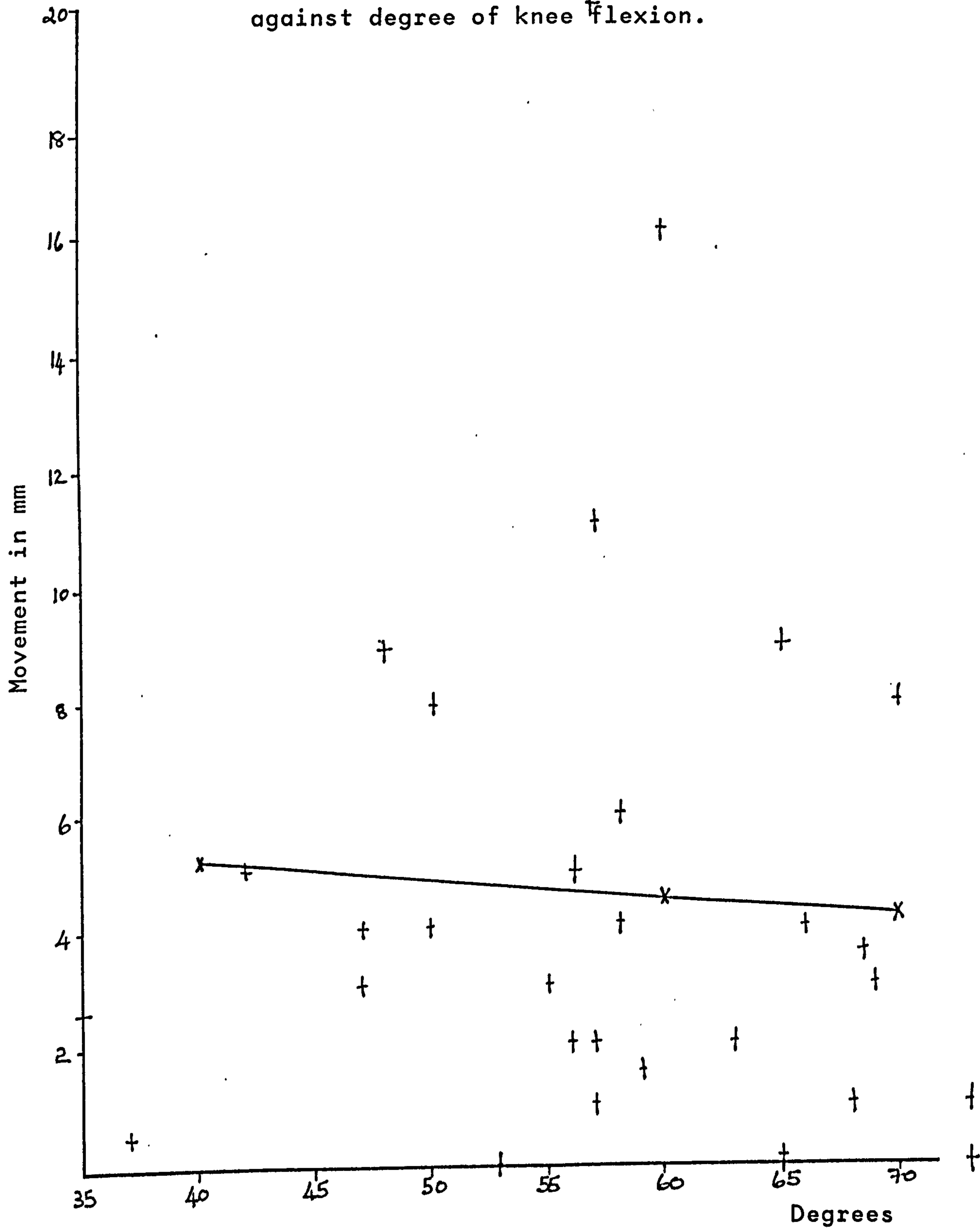
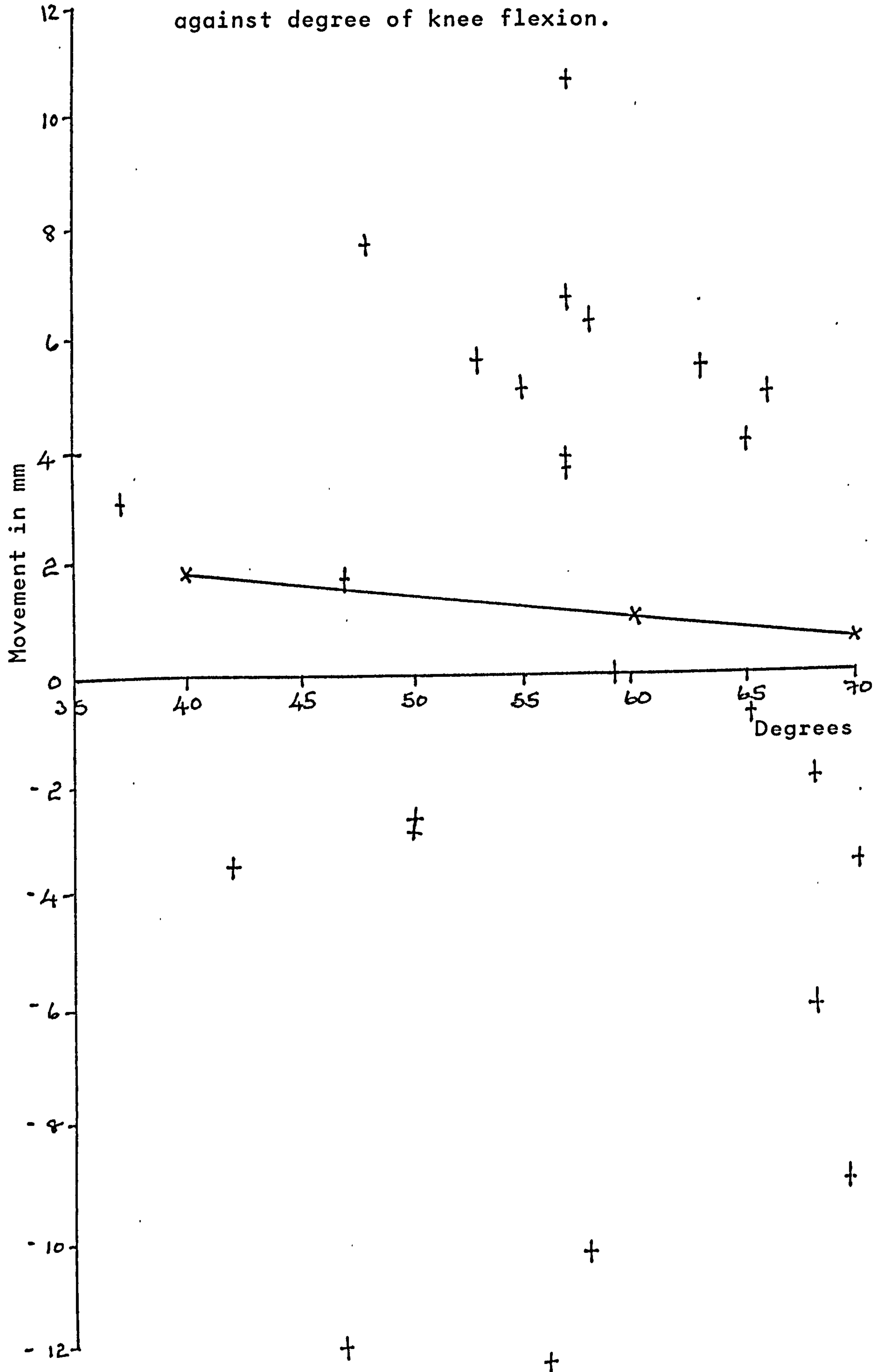

Figure 13

Movement of landmark in the y-direction on the femur

against degree of knee flexion.



CORRELATION COEFFICIENTS OF KNEE ANGLE AND  
LANDMARK MOVEMENT.

Limb Segment	No.	r	t	Sd/NSd
Femur x	33	-0.094	-0.519	Nsd
Femur y	33	-0.058	-0.319	Nsd
Tibia x	34	0.019	0.105	Nsd
Tibia y	34	-0.208	-1.206	Nsd

Key

r        Correlation coefficient  
t        Student's t  
Sd/NSd   Significantly different or not.  
x        X direction movement  
y        Y direction movement

Table 14

1. For the tibia the average magnitude of displacement was 5.1mm. Taking account of direction of movement the landmarks moved on average 2.4mm inferiorly over the tibia on knee flexion.

2. For the femur the average magnitude of displacement was 5.8mm. Taking account of direction of movement the landmarks moved on average 1.2mm superiorly.

3. The markers moved anteriorly/posteriorly in the sagittal plane an average of 4.5mm on the femur and 6.5 mm on the tibia.

The correlation coefficients shown in Table 15 were derived in order to give a measure of how accurately the markers can be placed over the underlying bone. Here correlation of bone width with distance of landmark to mid-shaft of the bone has been carried out. For the tibia,  $r$  is not significantly different from zero, whereas the  $r$  value for the femur is (using a significance level of 0.01). Hence for the tibia the accuracy of marker placement seems to be independent of the bone width at the level of marker placement. The correlation between distance moved vertically and distance moved horizontally was also calculated. The results are shown in Table 16.



CORRELATION COEFFICIENTS OF BONE WIDTH AND  
LANDMARK LOCATION.

Limb Segment	No.	r	r(2)	t	Sd/NSd
Femur	33	0.488	0.238	3.115	Sd
Tibia	34	0.095	0.099	0.541	NSd

Key

r            Correlation coefficient  
r(2)        Variance  
t            Student's t  
Sd/NSd     Significantly different or not.

Table 15

CORRELATION COEFFICIENTS OF DISTANCE MOVED

HORIZONATALLY AND VERTICALLY.

	Limb Segment	No.	r	r (2)	t	Sd /NSd
ALL	Femur	32	0.307	0.094	1.767	NSd
	Tibia	34	-0.149	0.022	-0.854	NSd
Con	Femur	5	0.400	0.160	0.757	NSd
	Tibia	5	-0.52	0.270	-1.055	NSd
Ucn	Femur	17	0.483	0.233	2.135	Sd
	Tibia	16	0.024	0.001	0.091	Nsd
Nat	Femur	8	-0.028	0.001	-0.680	NSd
	Tibia	11	-0.267	0.078	-0.833	NSd

Table 16

Key

r Correlation coefficient  
r (2) Variance  
t Student's t  
Sd/NSd Significantly different or not.  
Con Constrained type prosthesis  
Ucn Unconstrained or semiconstrained types.  
Nat Natural knees

### 2.3 Inferences

It does not necessarily follow that marker placement is more accurate on the femoral segment, because of the higher correlation values for the femur, but simply that tibial bone width plays little part in the accurate placement of the tibial segment marker. Of the two limb segments it is easier to palpate the tibial anatomical landmarks and presumably their placement is more accurately carried out. However this is of limited importance as we are comparing the "before and after" radiographs and accuracy of placement is hence irrelevant.

The large inter-subject variation could be due to a number of factors, three of which are listed below.

1. The patients in this study had a variety of skin types. These included the very flaky dry skins and at the other extreme those with a waxy soft appearance. It is suggested that these extremes of skin types have different adhesive properties which could account for markers moving more on some patients than on others.

2. The patients who took part in the study, as can be seen from table 3, did not all have the same type of knee joint replacement, and several still had

their natural knees. This, alone with the extent of the disease process may well have changed the bone/skin relationship in terms of relative movement. This could then be another contributory factor in the large spread of data.

3. The patients did not all have the same range of movement. Even though the author requested x-rays to be taken in approximately 60 degrees of flexion the recorded knee flexion angle was on average 57 degrees with a standard deviation of 11 degrees. Again, this may have contributed to the spread of data.

We may conclude from this evidence that marker movement relative to underlying bone does take place. The extent of this movement at the two sites used varies widely between subjects. It is suggested that introduction of an error factor to take account of this movement could only be successfully implemented if each patient was put through a more rigorous form of the above investigation. This is obviously unethical and impractical, so we are left with the option of always having to be aware of this phenomenon of landmark movement.

3.0 CODA-3 Output Reliability.

## Introduction

The CODA-3 system's manufacturer stated in the specifications that the positional resolution of the prismatic landmarks can be calculated from the formulae below:-

$$\text{Transverse and Vertical Axes} = 0.1Z \text{ mm}$$

$$\text{Longitudinal Horizontal Axes} = 0.1Z^2 \text{ mm}$$

Where Z is the distance of the landmarks in metres from the scanner unit, and Z<sup>2</sup> is Z squared. These calculations are based on a scanning frequency of 300Hz. Table 17 shows the absolute resolutions for sampling rates of 300 and 50Hz. It has been suggested that in typical applications the resolution is in the order of 0.2mm. The system installed in Orthopaedics has a sampling rate of 250Hz, and is used at a distance of about 4 metres (ie the activity being monitored is situated at around 4 metres from the scanner unit). The output from CODA-3 which is continually updated on the VDU, can be changed to give a finest resolution of 1/10 mm up to the coarsest resolution of 1mm.

After the preliminary studies quantifying marker movement over skin relative to the underlying bone, a decision was made to look only at CODA data to the

ABSOLUTE RESOLUTION IN MM

Distance (Z) in m	At 300Hz		At 50Hz	
	X,Y axes	Z axes	X,Y axes	Z axes
3	0.3	0.8	0.2	0.2
4	0.4	1.4	0.2	0.4
6	0.5	3.0	0.3	0.9
8	0.7	6.0	0.4	1.6
10	0.9	9.0	0.5	2.5

TABLE 17

nearest 1 mm. After weighing up the disadvantage of increased run time of programmes using the higher resolution data, it was decided that a faster system with data which was still very accurate compared to many other systems, would be the right choice.

A series of tests and experiments were formulated to investigate the nature of the CODA-3 output. They were put into two broad categories, namely, static and dynamic. As with the previous set of tests each one follows on from the last, drawing conclusions from the results it rendered and using these to formulate the next experiment. Only the digital output was looked at, although the facility for using the analogue output was available through multiplexed and continuous lines.

### 3.1 Static Tests

#### 3.1.1 Methods

As a test of the stability of the CODA output the position of two landmarks picked at random from the eight available was recorded over a period of three quarters of an hour. They were mounted at approximately one third of a metre (in all three dimensions) away from one another and their position noted down from the visual display unit. The CODA scanner itself had been given the warm up period

specified by the manufacturers.

### 3.1.2 Results

The results from this test are shown in table 18. It can be noted that landmark number one had been nominated as the origin of the system, (as described in the Chapter on Equipment). In some cases a range of values for the position of the landmark has been given, which means that when that particular sample was being taken the coordinate values were moving between those values. A drift in the coordinate values can be seen to have taken place over the sample period. A typical gait analysis session is unlikely to take longer than the time taken to conduct this test. So in the worst case a drift in the output from CODA-3 of a maximum of 2mm in the x-direction, 4mm in the y and z-directions. This of course is assuming that landmarks one and five typify all the landmarks.

### 3.1.3 Inferences

As the samples were taken only once every 15 minutes we cannot be sure just what was happening to the coordinate values at times in-between. The values may have been drifting to a much greater extent than is apparent from the results in table 18.



POSITIONAL DATA FROM STATIC

LANDMARK TEST.

X, Y or Z Direction		Landmark Number	
		1	5
Run 1	X	0	361
	Y	0 - -1	-329 - -330
	Z	0 - -1	403 - 404
Run 2	X	0	360
	Y	0 - -1	-331
	Z	0 - -1	401 - 402
Run 3	X	0	359
	Y	0 - -1	-332 - -333
	Z	0 - -1	400 - 401
Run 1	after 15 minutes		
Run 2	after 30 minutes		
Run 3	after 45 minutes		

TABLE 10

If we assume that our sample is representative of all samples within the test period we can conclude from this test that the CODA-3 system, when used with stationary landmarks, and assuming that all landmarks behave in a similar fashion, produces positional data which drifts within acceptable limits over the time period during which it is likely to be expected to work. Although not detailed in the method it became apparent that a situation of cross-conflict between landmarks existed (as had been mentioned by the manufacturers). A fuller investigation of the nature of this condition was carried out and details of the experimentation will be described in the next section.

### 3.2 Dynamic Tests

The static test left the author with the impression that the output from stationary landmarks drifted within acceptable limits for the purpose of gait analysis work. However the whole idea of gait analysis is to be able to monitor the movements of the body during locomotion. Therefore any system used to record body movements must produce output which is stable in the dynamic situation. The author had to satisfy herself that the positional information about moving landmarks was reproducible. A test of this would be to check that the positional data for a landmark undergoing cyclical movement was the same for

each repetition of the cycle. She also had to be sure that all the CODA-3 landmarks produced the same positional information when subjected to the same movement pattern.

The first experiment describes the test rig the author made to produce motion of known velocity, onto which the landmarks could be attached. Still relying on the positional information about the landmarks shown on CODA's VDU, the similarity of their output was observed. It became apparent that collection and display of data through another system would be required, and the next series of experiments used such a method to compare landmark positional data.

### 3.2.1 Method

A record turntable was modified so that landmarks could be mounted on it with it in almost a vertical position rather than a horizontal one. This was to ensure that the landmarks would be seen by the scanner unit, but obviously had the disadvantage that the turntable would not be working under optimal conditions. A large sheet of polystyrene was shaped to fit over the turntable which allowed pinning of the prisms onto it using the watch-strap assembly on their bases. Four concentric circles were drawn onto the sheet, using felt tip pen and a rig comprising a retort

stand and clamps to aid accurate drawing. These were drawn at 280, 250, 200 and 150mm from the centre of the turntable. Eight equidistant lines were drawn onto the circumference of each circle, to act as sites for placement of prisms. The similarity of positional data from the markers was then tested by placing the markers, in turn onto the turntable on the 250mm line. The slowest speed ie. 16rpm, was chosen for ease. The only practical way of recording the positional information was by noting down the maximum and minimum values from CODA-3's VDU.

### 3.2.2 Results

Table 19 shows the maxima and minima values for the eight landmarks when placed as described above. One possible reason for the difference in positional data for the eight landmarks is that the landmarks were placed on the turntable individually and an error in their location would have resulted in a difference in the maximum/minimum values.

However there are some very obvious discrepancies within the coordinate data which the author knew could not be due to the misplacing of the landmarks on the turntable. These differences between landmarks proved to be a hardware problem. Subsequent action by the manufacturers allowed us to retest the positional data.

POSITIONAL DATA FROM DYNAMIC

LANDMARK TEST.

Landmark	Direction		
	X	Y	Z
1	-246 - 252	-3 - 493	5 - 69
2	-245 - 252	-1 - 499	0 - 66
3	-246 - 252	0 - 500	0 - 63
4	-251 - 247	-1 - 495	0 - 63
5	-250 - 252	-1 - 498	0 - 63
6	-238 - 251	-1000 - 506	-25 - 66
7	-250 - 247	-4 - 502	-219 - 2
8	-244 - 256	0 - 497	1 - 66

Table 19

this time using a data acquisition and display program written by the author and a colleague.

### 3.2.3 Inferences

This experiment, although apparently useless in terms of a test of the reliability of the system, did in fact prove to be very useful in that it highlighted the need for an update on the hardware, and allowed time for the development of software which allowed the results to be visualised more easily, providing a more satisfactory method of looking at CODA-3 output. Not all the landmarks in the test were affected by the hardware problem, and those that were not showed that the output from moving landmarks was remarkably similar. Finally this experiment produced a test rig which produced repetitive motion, both in terms of speed and direction.

### 3.3 Data Capture on Laboratory Computer

The following set of experiments used a piece of software which ran on the laboratory computer, it took the digital coordinates of the landmarks and displayed them as a 3x8 matrix of plots of x,y and z distances against time. It also allowed for the collection of force plate data. The data collection period was

Limited to 2 seconds, with a sampling frequency of 100 Hertz. The poor resolution of the television screen is somewhat limiting, however the display gives a clear enough picture of events for our purposes.

### 3.3.1 Method

This experiment was performed to test the effect on positional data of varying the number of landmarks in the field of view, the speed of movement and the combination of landmarks ie. their position in terms of their colour.

Firstly the number of landmarks placed on the turntable revolving at 16rpm was increased one by one until all landmarks were on the table. The choice of position on the turntable was made with the aid of a table of random numbers. Copies of the screen display are shown for each run. (Appendix C Figures 1-8).

The second test involved placing the eight landmarks randomly on the turntable, and looking at their positional information when the speed of the table was changed. Three speeds, 33, 45 and 78rpm were used and again copies of the screen display are shown. (Appendix C Figures 9-11).

Thirdly for a single speed of 16rpm, with all

eight landmarks sited on the turntable, copies of the tv screen display for various locations of the landmarks relative to one another were made. The diagrams shown are typical of the outputs obtained but obviously many more than those shown were actually tested. (Appendix C Figures 12-16).

All the tests were performed at a distance of 4.5m from the scanner unit, with the landmarks placed on the concentric circle at 250mm in test two and at 280mm in test one.

### 3.3.2 Results

Expt. 1- Two patterns of motion were expected dependent upon the orientation of the turntable. With the turntable horizontal (as when 1,2 and 4 landmarks were used), we would have expected sinusoidal motion in the x and z directions. With the turntable vertical, sinusoidal motion would have been expected in the x and y directions. In both cases the third dimension was expected to be a near flat pattern. From the plots it became evident that as more landmarks were added to the turntable the amount of missing data increased until, with eight landmarks, the data were incomprehensible and far from what was expected.

Expt. 2- A number of turntable positions were



used and samples of the output are shown. In all directions it could be seen that as the speed of motion increased the amount of lost data decreased. The missing sections show up as either gaps in the data or points on the plots away from the expected sinusoidal or straight line pattern that had been expected.

Expt. 3- Comparison of the output from experiment three allowed the author to conclude that position of the landmarks relative to one another did not affect the consistency of the positional information, at least as seen at 16rpm. Extrapolating from the previous experiment it was assumed that altering the speed of movement would improve the output across the board.

### 3.3.3 Inferences

Several conclusions can be drawn from this set of experiments, as follows.

1. The minimum number of landmarks possible should be used.

2. Monitoring of slow moving events may cause problems.

3. The combinations of prisms used does not matter.

4. An addition to the software should be written to highlight areas of cross conflict between landmarks.

From these conclusions the author became aware that she would be limited in the number of landmarks that could be used at one time. Care would have to be taken to reduce the incidence of cross conflict when performing gait analysis.

The following is an extract from the manufacturers specifications which describes in more detail the cross conflict between landmarks.

When a pair of landmarks come into a vertical or horizontal alignment in the field of view of any one of the scanners they are said to be in cross point conflict. The vertical or horizontal distance between landmarks at which such conflict commences is approximately 15mm (centre to centre).

The CODA-3 software recognises this condition and continues to output coordinate data predicted from the previous velocity history of the landmarks affected. The predicted values are output for up to 0.1s. If the landmarks have not separated by this time they are declared out of view and their coordinate outputs are held at the last seen value until the conflict clears.

Bearing in mind the above limitations the following chapter looks at a method of mounting the landmarks on the lower limb to reduce cross conflict and discusses the further developments of the software and it's validation. Firstly however the setting up of the gait data collection protocol is reported, followed by a discussion of the preliminary pilot studies in gait analysis.

## EXPERIMENTS.

# EXPERIMENTS

## 1.0 INTRODUCTION

1.1 Walkway

1.2 Knowledge of Results

1.3 Protocol for gait data collection

## 2.0 Pilot Study

2.1 Method

2.2 Results

2.3 Inferences

2.4 Conclusions

## 3.0 Platina method

3.1 Introduction

3.2 Method

3.4 Inferences

## 4.0 Software development

4.1 Testing

4.2 Results

4.3 Discussion and Inferences

5.0 Reproducibility and Speed effect on  
Velocity Profiles

5.1 Method

5.2 Results

5.3 Inferences

6.0 Abnormal Gait Patterns

6.1 Method

6.2 Results

6.3 Inferences

7.0 Acceleration Profiles

7.1 Simulation of Joint laxity

7.1.1 Method

7.1.2 Results

7.1.3 Inferences

7.2 Knee Accelerations

7.2.1 Method

7.2.2 Results

7.2.3 Inferences

8.0 Supplementary Experiments

8.1 Pelvic Velocities

8.2 Sagittal and Coronal Plane

Knee Angles

8.3 Knee Dimensions

## EXPERIMENTS.

### 1.0 Introduction

As stated earlier human locomotion is a set of movements phased together, ideally executed with minimum energy output and maximum efficiency. Although having essentially similar anatomy the population varies widely in its anthropometric makeup, there being both an inter and intra sex difference. This is probably one of the contributory factors in the large number of styles of gait that human beings use, ie the variability of gait. This variability results in many of the parameters of gait having large ranges within which the normal population lies. This phenomenon is evident in the natural environment but even more so when put under scrutiny within the laboratory situation.

In order to minimise the effect of these laboratory conditions on the gait patterns of our subjects, our aim should be to cause the least disturbance possible to their natural rhythm of gait. The walkway around which we use our measuring devices is where we can start to implement this idea of minimal interference.

## 1.1 Walkway

Using one subject naive of gait data collection procedures, the author, by questioning determined the length of walkway either side of the force plate and within the field of view of CODA-3, which allowed the subject to "get into her stride". This it was hoped would allow the subject to produce as near a natural gait as possible for the few strides where the gait data collection is carried-out. Shortening the walkway on the far side of the force plate from the starting point resulted in the subject slowing down whilst walking over the plate in anticipation of the end of the walkway. Equally, shortening the walkway on the other side didn't allow time for her to get into a natural rhythm before she had to walk across the plate.

Added to this problem of walkway length, the author had to decide whether to mark on the floor tram-lines to give the impression of a pavement or naturally occurring walkway. This idea is used in many centres, particularly where the walkway stretches across the diagonal of the laboratory space. As ours is parallel with a wall it was felt that this would be sufficient to give the subjects a guideline, which they invariably have, of one form or another, in their natural environment.



A third area for consideration is whether we should disguise the force plate to prevent aiming by the subjects. It was decided that as some of our subjects would have difficulty in performing many repetitions of the gait cycle, we could not, for their own comfort have them walking on the walkway a large number of times until they hit the plate. Instead they were positioned at the start of the walkway and by choosing the appropriate starting leg and adjusting their starting point slightly, they would be planting the foot of our choice on the plate with no conscious effort on their part. Each walk was watched, by reflection so as not to distract the subject, to be sure that he or she was not aiming for the plate and hence using an unnatural gait style.

### 1.2 Knowledge of Results

It would be quite easy to give the subjects information about their performance for one particular run, i.e. how fast they were walking, how smooth their walk had been etc. etc.. To what extent this would alter the subject's gait style was unknown, so it was decided that there would be no knowledge of results transmitted to the subjects. The only communication would be in the way of verbal instruction to position the subject correctly at the start of the walk and to get them to execute the walk correctly. The computer used for data

collection produces a bell sound to indicate the start and end of data collection. The subjects however were only given the information about the bell for start of collection to prevent the possibility of their anticipating the end of the run.

Rest periods of one minute duration were allocated between each run leaving it to the individual whether they sat or not. A longer break was necessary to allow for alterations to be made to the equipment between tests on left and right legs. This gave a natural break in the test session and all subjects remained seated during this rest period.

### 1.3 Protocol for gait data collection

On entering the laboratory the subjects were asked to put on a pair of shorts and roll down their socks. Those female subjects wearing skirts or dresses were asked to roll down or remove any leg wear, as appropriate. This would allow for placement of the markers. The subjects were made to feel as comfortable as possible in their strange attire, and the author was the only person in the laboratory at the time of testing. No instructions had been given to subjects about footwear and it was assumed that they were comfortable in the shoes of their choice. (The author is aware of the effect heel height may have on the

measured parameters of gait). They were instructed to remain shod during the experiment, as this for most individuals was their usual habit.

At the time of testing patients clinical notes were available to allow an assessment of their prevailing condition. Subjects were also questioned about their condition at the time of testing and involvement of other joints was noted. Particular attention was paid to the patients subjective assessment of pain at the time of testing.

(The CODA-3 equipment necessitates carrying out data collection for each limb separately. Justification for this is made by highlighting that as gait is such a variable activity the error incurred by having two separate runs for each leg would be less than the difference between two runs.)

The CODA-3 prisms were then attached to the leg under investigation and the subjects instructed to walk the length of the laboratory and back again. This procedure allowed for any increase in leg volume which might take place and the subsequent adjustment of the straps if necessary. Each subject was free to choose their own speed of locomotion and as mentioned earlier

was discouraged from aiming for the plate and hence giving false data. It was felt that attempted control over the factors of speed, stride length or cadence, would alter unnecessarily the parameters of interest.

Once positioned at the appropriate starting point the subject walked the length of the walkway and then waited for the verbal instruction to repeat the procedure. Examination of the data took place at this time along with storage of good data on floppy disc.

## 2.0 Pilot Study Using Above Protocol

### 2.1 Method

Following the procedure laid out above, a 35 year old asymptomatic female volunteer acted as the subject in an experiment to acquire a picture of the pattern of raw data output from markers placed on the lower limb. Bony landmarks were used to locate CODA-3 prisms over the tibial and femoral shafts and on bony points on the ankle and knee. Below are the sites of the landmarks:-

LM 1 Lateral malleolus

LM 2 Head of fibula

LM 3 Tibial tuberosity

LM 7 Lateral femoral epicondyle

LM 4 Greater trochanter of femur

## LM 3 Anterior surface of femur

### 2.2 Results

Figure 15 and 16 are the raw data acquired for one run showing the positional data for a set of markers sited as above on the right leg. The stance and swing phases are marked on the raw data outputs as is a brief description of the shapes of each trace. This was typical of all subsequent tracings and the following are features which are evident in all of them. (Note that the x-direction is defined in terms of the Laboratory and not anatomically, whereas z and y comply with the conventional co-ordinate system see Figure 1).\*

#### Landmark 1

In the x-direction there is a marked plateauing during the stance phase. As the foot traverses the field of view in the swing phase the x-direction values decrease rapidly. In the y and z directions there is little if any change apparent from the tracings, this may in part be due to the large scale over which the plots are drawn.

#### Landmark 2

At heel strike the head of the fibula is posterior to the foot marker, but moves anterior to it as toe-off is approached. The time over which the plateau occurs

Figure 15 Raw CODA data showing swing and stance phases.

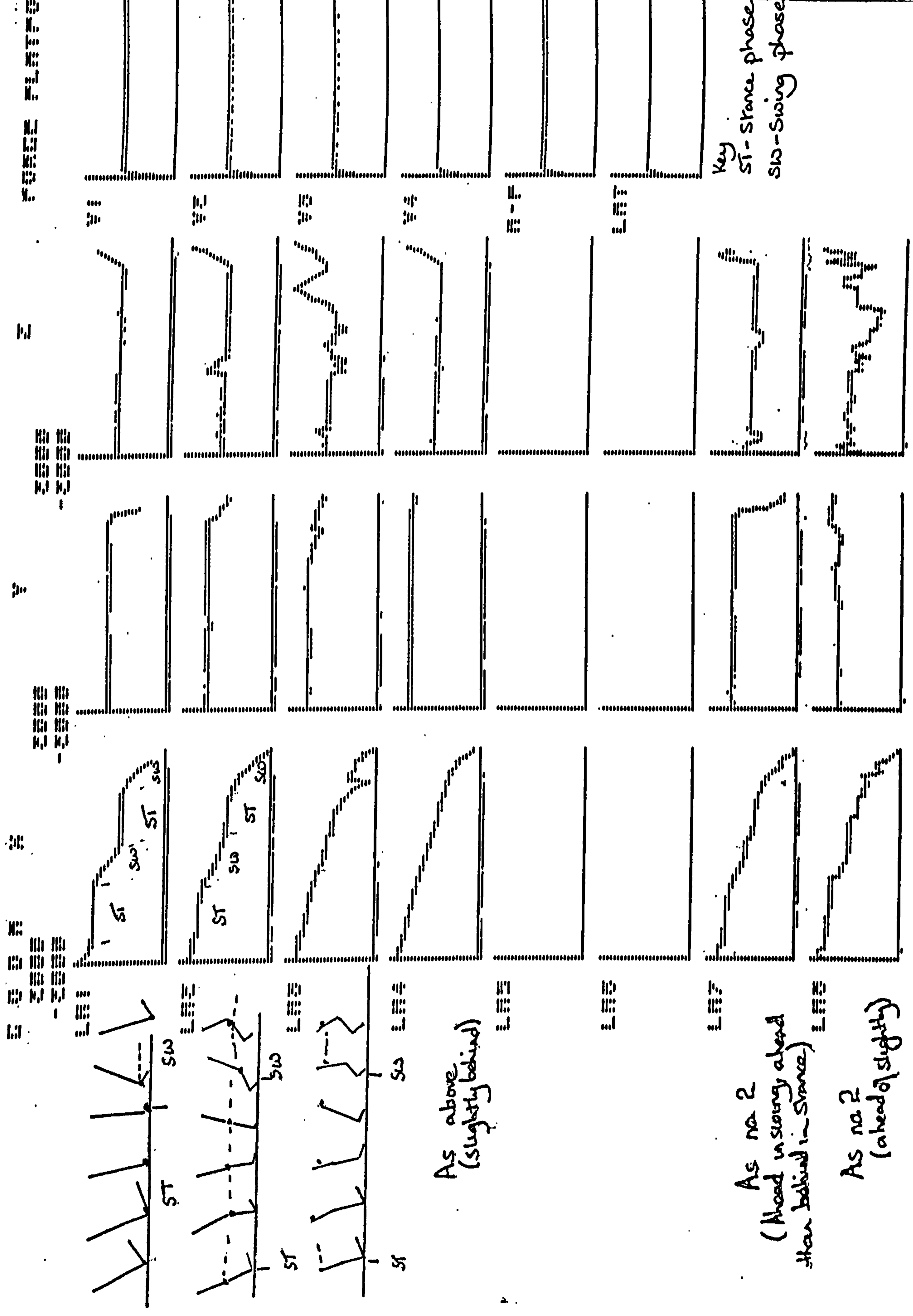

Key  
ST - Stance phase  
SW - Swing phase

As above  
(slightly behind)

As no 2  
(Ahead in swing ahead  
than behind in stance)

As no 2  
(ahead of slightly)

Figure 16 Raw CODA data with brief description of the curves.

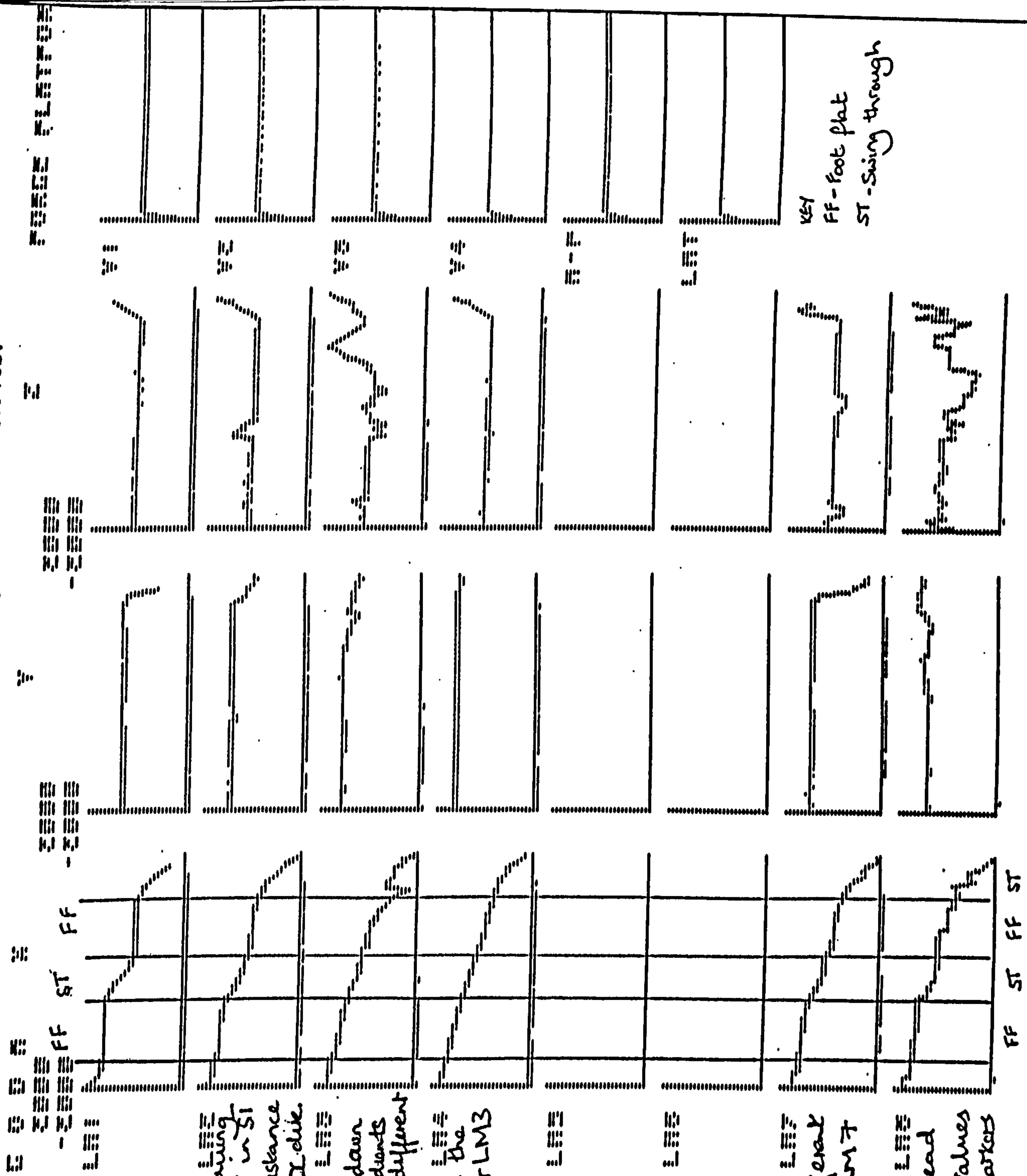

ST less definite plateauing  
 Slow rate of movement in ST  
 Measurement diff in distance  
 along line of progression in I. die.  
 ction.

No discorable slowing down  
 of movement at HS, gradients  
 in FF & ST are slightly different

Even less variation in the  
 direction than for LM3

Compare with LM2  
 Timing of plateauing different  
 i.e. FF occurs earlier in LM7

Should be slightly ahead  
 of LM2 in its X-values  
 However no in view markets  
 So values cannot be  
 relied upon

is less than that for landmark one, as the head of the fibula is still moving after the foot is planted on the ground. From the slope of the curve it can be seen that the velocity of motion of landmark one is greater than that of landmark two during the swing phase. This is explained by the occurrence of the higher velocity of the distal portion of the limb compared with the more proximal parts.

#### Landmark 3

The marker on the front of the thigh illustrates a steady decrease in x-direction value with a slight difference in gradient between stance and swing phases. There is little change in the y-direction values and very poor results for the z-direction component. This may in part be due to internal rotation of the femur obscuring the landmark from the scanner unit.

#### Landmark 4

There is a similar trend here as there is for landmark 3. As would have been expected the starting value in the y direction is higher in 4 compared with 3. The general pattern seems to be one of a steady decrease in x value (ie a constant velocity) with minimal change in the y and z values.

#### Landmark 7

The lateral femoral epicondyle exhibits behaviour



similar to that of landmark 2, but with different timing of the period of plateauing. Again the y and z values remain fairly steady.

#### Landmark 8

The reliability of data for Landmark 8 is very doubtful as there is almost total absence of an in view marker.

Figures 17 to 22 are the distances between the specified landmarks over the two seconds of data collection, as calculated by the computer. The mean, standard deviation and error for each are shown. In the table of distances many values which lie outside four standard deviations from the mean is marked with an asterisk, and this datum value is removed from the sample resulting in a reduced sample number n. This identified those data values where for some reason the information was incorrect. It was assumed that all the distances would remain within a very close range, giving a small standard deviation and standard error, however this was not the case.

Because of their location we would have expected distances between landmarks 1 and 2, 1 and 8, and 2 and 8 to have a small standard deviation, variability arising due in the main to landmark movement over skin. However all but the distance between landmarks 1 and 2

Figure 17 Distance between landmarks 4 and 7

Which two landmarks ? 4,7

322.1	321.8	323.8	338.5	367.6	408.2	461.6*	394.5	393.3	334.9
330.4	475.5*	636.1*	609.3*	601.8*	593.2*	585.6*	578.3*	570.5*	323.2
317.5	316.1	321.0	335.7	356.2	314.3	318.2	317.5	318.5	320.2
330.5	327.7	325.8	326.1	325.6	326.5	327.4	327.4	328.4	328.1
321.5	316.4	318.3	314.6	316.9	322.9	324.4	327.1	317.6	324.6
314.9	336.6	327.2	325.7	326.4	326.0	326.5	327.3	328.6	327.3
326.6	326.8	326.1	326.3	326.8	326.6	326.1	327.3	327.5	327.9
327.4	328.9	327.9	326.2	325.6	324.4	322.4	320.6	334.1	358.9
345.1	324.1	318.8	317.2	316.8	318.5	319.5	320.8	319.8	319.4
319.5	318.2	318.9	319.1	320.6	307.2	289.2	291.4	306.3	314.2
326.8	343.3	365.7	385.9	404.4	423.1	445.5	444.7	444.0	444.0
443.8	443.5	444.5	323.1	321.8	326.5	332.7	334.4	329.4	340.5
356.8	341.4	319.9	315.8	316.0	331.7	343.7	343.5	329.4	326.3
322.8	326.3	330.1	326.7	327.4	331.1	336.7	330.7	328.8	329.2
327.9	327.5	328.8	328.4	329.3	330.5	330.3	330.1	330.4	329.6
330.5	329.5	329.3	329.3	329.8	329.2	328.7	329.5	331.2	331.3
333.1	332.5	330.0	326.6	324.5	320.0	316.7	314.3	315.8	319.2
325.0	330.5	335.7	338.6	340.4	335.1	347.8	359.0	369.8	379.8
1032.9*	1070.2*	1105.8*	1152.9*	1194.1*	1234.0*	1274.9*	1845.0*	1871.5*	1909.1*
1994.6*	2099.1*	2186.4*	2301.6*	2452.8*	2515.3*	2349.6*	2398.7*	2422.5*	2433.9*
Mean, s.d., s.e. and n =			335.05	28.84	2.21	171			

Which two landmarks ? 4

Figure 18 Distance between landmarks 7 and 3

**Which two landmarks ? 7,3**

193.2	198.7	190.8	190.3	205.6	222.1	246.6	195.0	236.3	192.6
301.1	488.4	666.0	671.2	715.5	762.4	813.4	867.6	928.1	564.7
612.7	646.2	678.1	205.3	213.8	191.1	197.3	225.8	207.5	191.1
189.6	190.2	190.8	190.6	191.0	190.7	192.4	192.4	194.2	194.5
195.6	196.3	197.0	197.6	199.6	200.7	201.3	204.1	201.5	202.4
205.0	205.3	204.4	205.2	205.6	206.1	206.2	207.4	207.6	207.2
207.0	207.8	208.4	208.8	208.6	208.6	209.3	209.9	210.5	210.5
210.2	211.0	210.2	209.3	209.7	208.7	207.4	554.7	569.1	549.4
478.3	367.8	261.0	210.6	481.5	531.3	580.7	628.3	196.9	188.6
188.1	189.1	190.2	188.4	200.8	231.7	285.6	355.6	403.6	448.5
676.0	743.0	354.3	400.6	424.3	431.4	431.4	432.0	432.3	432.6
432.9	432.9	432.6	571.0	586.5	631.3	189.1	195.8	202.2	207.2
208.1	211.1	213.9	218.5	221.9	224.4	226.2	228.7	231.3	233.1
235.4	253.2	254.9	257.5	256.5	252.8	423.1	435.4	439.9	439.7
1030.9	1064.8	1121.5	1181.0	1239.6	1303.3	1376.0	1455.1	1538.0	1629.4
1731.8	1841.5	1959.5	2088.8	2226.4	2375.1	2541.7	2723.5	2926.5	3148.2*
3390.8*	3665.1*	3979.8*	4329.1*	4712.6*	5129.6*	5583.5*	6076.1*	6609.3*	490.1
540.9	522.7	483.9	442.2	423.4	485.4	494.9	490.1	488.5	482.5
456.7	509.1	625.1	750.1	870.3	985.8	1097.2	1411.3	1541.8	1368.8
1457.2	1572.1	1676.7	1857.6	2107.0	2241.6	2041.4	1727.0	1744.4	1772.8

Mean, s.d., s.e. and n = 582.34 588.08 42.66 190

**Which two landmarks ?**

Figure 19 Distance between landmarks 4 and 3

**Which two landmarks ? 4,3**

210.2	208.9	208.6	209.8	214.9	231.9	253.5	287.4	211.0	227.3
222.3	208.8	205.3	217.7	248.0	285.9	332.2	383.3	443.0	509.6
579.5	654.6	731.5	185.8	192.8	193.1	206.2	243.9	223.1	199.0
202.1	204.8	203.8	204.4	202.7	204.0	203.5	204.3	203.3	204.1
189.5	177.5	181.1	171.7	175.8	188.6	191.9	190.3	192.0	207.1
194.8	202.3	203.6	204.3	203.3	203.9	203.9	203.5	204.4	204.6
203.9	203.7	203.4	202.3	203.3	201.9	201.1	200.3	199.9	199.1
198.6	198.2	197.5	196.9	196.1	194.5	193.9	471.8	435.0	361.2
322.5	274.2	199.8	173.7	438.8	480.7	516.2	562.3	212.3	192.7
190.7	191.0	190.4	187.9	213.1	247.4	294.9	320.1	322.2	317.5
511.1	536.7	161.0	164.7	177.6	480.0	192.9	159.4	140.8	143.1
98.7	94.8	96.2	431.3	445.1	113.2	122.1	123.3	117.9	122.4
158.6	133.8	120.6	151.4	131.0	291.1	515.0	515.3	513.9	514.0
128.8	276.4	293.3	288.5	289.9	1396.1*	1469.8*	1548.5*	1630.4*	1720.7*
1119.2*	1152.8*	1212.0*	1271.3*	1330.6*	1456.9*	2621.6*	2805.2*	3012.2*	3235.9*
1821.4*	1929.1*	2046.5*	2174.9*	2309.9*	2203.8*	5652.2*	6143.4*	6677.7*	525.7
3483.8*	3758.8*	4069.3*	4413.5*	4791.0*	5829.2	616.8	625.4	634.0	641.9
595.8	725.6	695.9	658.7	639.4	473.2	455.6	448.2	493.4	618.0
655.0	646.9	590.4	543.2	502.5	723.3	792.1	757.8	756.4	694.9
560.9	538.2	541.8	575.8	644.9	.21	14.09	171		

Mean, s.d., s.e. and n = 313.30 184.2 14.09 171

Which two landmarks

Figure 20 Distance between landmarks 1 and 2

**Which two landmarks ? 1,2**

331.3	320.8	315.3	316.4	311.5	315.8	327.7	325.2	325.2	335.0
336.6	329.7	324.5	324.5	327.9	341.3	360.8	385.4*	415.0*	447.1*
324.8	321.9	327.3	334.2	335.7	323.2	317.2	316.0	313.2	320.4
322.0	311.4	299.4	287.1	297.6	350.0	502.9*	376.2*	354.9	354.7
317.5	314.6	299.7	301.9	336.3	330.0	325.1	303.1	301.5	335.6
325.4	325.0	323.4	324.0	324.0	324.8	326.3	325.2	324.5	325.1
325.1	325.6	326.1	325.1	326.7	326.5	325.8	324.7	324.9	323.5
323.3	324.0	323.4	320.6	319.9	319.3	317.9	902.0*	811.8*	767.9*
727.5*	689.0*	639.2*	493.6*	468.0*	534.0*	445.1*	411.6*	358.7	311.9
312.2	322.6	326.0	315.7	312.7	315.3	315.4	325.2	324.1	325.6
323.5	327.2	332.2	332.5	330.9	329.2	327.8	328.1	327.3	327.4
325.7	326.9	328.8	331.2	335.4	345.0	336.6	315.1	319.8	340.1
343.9	339.5	331.8	328.2	326.2	324.2	325.7	320.2	319.5	324.8
326.3	359.7	360.8	329.5	329.8	329.2	329.4	330.1	329.6	329.1
330.1	329.9	330.7	330.7	331.0	331.4	330.8	332.0	332.0	331.7
331.0	330.7	331.1	330.4	330.2	329.1	329.2	328.9	328.6	327.4
326.6	325.1	324.6	322.6	322.2	321.1	321.2	321.5	321.5	323.0
322.8	325.5	327.3	323.7	326.2	332.4	337.8	346.0	216.4*	202.9*
188.6*	169.9*	148.5*	125.5*	101.0*	80.4*	958.5*	967.7*	971.7*	963.7*
963.3*	8130.0*	9770.9*	12216.1*	15033.2*	17990.9*	20738.8*	22916.6*	24354.4*	25045.1*

Mean, s.d., s.e. and n = 326.34 10.75 0.84 162

Which two landmarks ?

Figure 21 Distance between landmarks 1 and 8

**Which two landmarks ? 1,8**

1095.5	271.5	280.7	351.2	454.6	543.8	640.2	746.4	281.9	280.1
280.2	279.6	279.1	278.5	288.7	309.4	338.0	370.4	407.1	373.4
317.0	319.3	352.7	297.0	325.8	348.3	340.6	324.4	335.3	328.4
303.4	316.5	365.1	424.0	470.7	465.7	498.8	448.7	431.4	416.0
370.4	314.7	296.6	309.0	296.3	299.9	303.1	366.1	281.1	283.8
282.9	283.3	283.1	280.2	278.7	279.9	280.3	282.5	283.9	281.9
279.7	277.7	275.1	272.6	270.0	267.4	263.3	258.3	254.0	248.1
242.3	236.7	231.6	228.7	226.5	225.2	1717.7	445.4	383.9	350.4
324.2	341.2	380.2	428.2	277.1	250.1	223.5	198.5	176.5	736.7
745.3	286.5	269.5	256.9	250.7	269.6	259.5	254.2	259.7	269.7
408.5	417.4	500.2	605.8	695.2	760.8	765.5	772.5	778.7	785.7
791.7	797.2	799.7	801.8	1042.0	1064.6	1081.8	1063.1	1076.2	1120.3
1138.7	1060.3	1061.0	1070.0	1072.3	1152.3	1168.8	1185.7	1221.4	1247.1
1256.3	1365.9	1384.1	1316.1	1315.0	280.0	277.6	277.0	276.1	278.3
277.2	276.1	274.5	273.0	271.7	270.4	268.4	266.5	264.1	261.5
258.1	254.3	251.0	246.0	716.0	714.2	713.4	712.9	709.8	706.1
720.5	715.3	710.7	703.5	696.9	408.4	386.9	364.8	343.9	325.4
581.3	573.8	763.0	788.6	894.8	1086.4	1154.5	737.0	958.8	1347.0
1150.0	778.8	767.3	963.2	1032.8	1118.1	1978.2	2035.9	1796.7	1810.2
1831.9	8770.2	10501.6	13021.7	15875.4	18837.5	21554.7	23664.8	25027.3	25612.6

Mean, s.d., s.e. and n = 565.30 398.54 28.84 191

Which two landmarks ?

Figure 22 Distance between landmarks 2 and 8

**Which two landmarks ? 2,8**

937.7	219.4	244.3	349.2	442.3	560.4	699.6	795.8	84.4	104.8
106.5	91.9	83.3	86.5	88.7	88.1	89.4	90.6	89.3	92.8
138.9	127.6	244.2	87.5	256.1	284.2	254.8	181.6	207.0	274.2
251.2	264.1	310.1	369.3	375.1	226.5	67.9	155.3	503.0	485.1
314.8	202.8	118.7	187.5	233.4	226.5	222.7	233.8	104.7	113.5
91.7	76.6	70.2	85.0	109.4	129.5	144.2	161.6	174.3	175.1
177.6	178.8	182.7	186.8	192.1	197.8	203.7	212.3	222.5	232.4
245.9	263.4	281.3	298.4	317.9	340.1	1815.7	1133.7	958.2	871.5
788.1	774.0	775.8	666.3	360.8	448.8	342.1	302.2	233.9	712.2
709.9	122.3	123.5	114.7	132.0	148.3	209.1	250.6	252.3	254.5
255.0	251.6	327.5	444.8	547.9	624.0	629.1	635.2	638.0	642.8
649.0	651.4	646.6	639.4	881.4	886.1	927.5	973.6	967.1	957.6
970.0	900.3	922.5	944.1	951.4	1038.4	1052.8	1091.4	1136.3	1140.4
1144.3	1177.0	1192.5	1199.7	1198.2	81.7	90.1	107.7	127.3	146.6
145.7	144.7	143.2	140.9	139.4	138.1	137.0	137.4	136.9	136.9
138.2	140.5	142.8	146.2	729.1	729.0	728.8	727.9	728.1	729.6
710.3	712.1	712.7	713.2	720.6	93.6	72.4	55.0	48.7	61.1
355.3	354.1	561.0	606.7	730.1	935.5	1008.3	497.5	946.0	1349.9
1148.4	760.4	746.1	947.3	1012.9	1079.2	1145.3	1210.6	826.1	853.0
896.5	958.5	1020.5	1082.9	1125.6	1148.1	1152.2	1136.8	1124.0	1106.9
Mean, s.d., s.e. and n =			488.37	384.42	27.18	200			

**Which two landmarks ?**

these standard deviations are large.

Likewise we would have expected distances between Landmarks 4 and 7, 7 and 3, and 4 and 3 to have had small standard deviations, but again all but the distance between landmarks 4 and 7 these values were high.

### 2.3 Inferences

The main point for note from this pilot study is the large number of times cross point conflict occurs. This is highlighted on the traces by the out of view line as a second horizontal axis, and on the distance data by the high standard deviations. Another possible explanation for these widely varying distances is that the landmarks have become physically obscured during the collection period and hence gave false data.

### 2.4 Conclusion

The main conclusion to be drawn from this pilot study was the need to be very careful when siting the landmarks to try and reduce the occurrence of cross point conflict. To eliminate this completely one would have to use only one landmark at a time and hence have to perform several runs per subject to collect all the kinematic data necessary to describe the movements of the knee.



PLATE 5 THE FIBULA PLATE

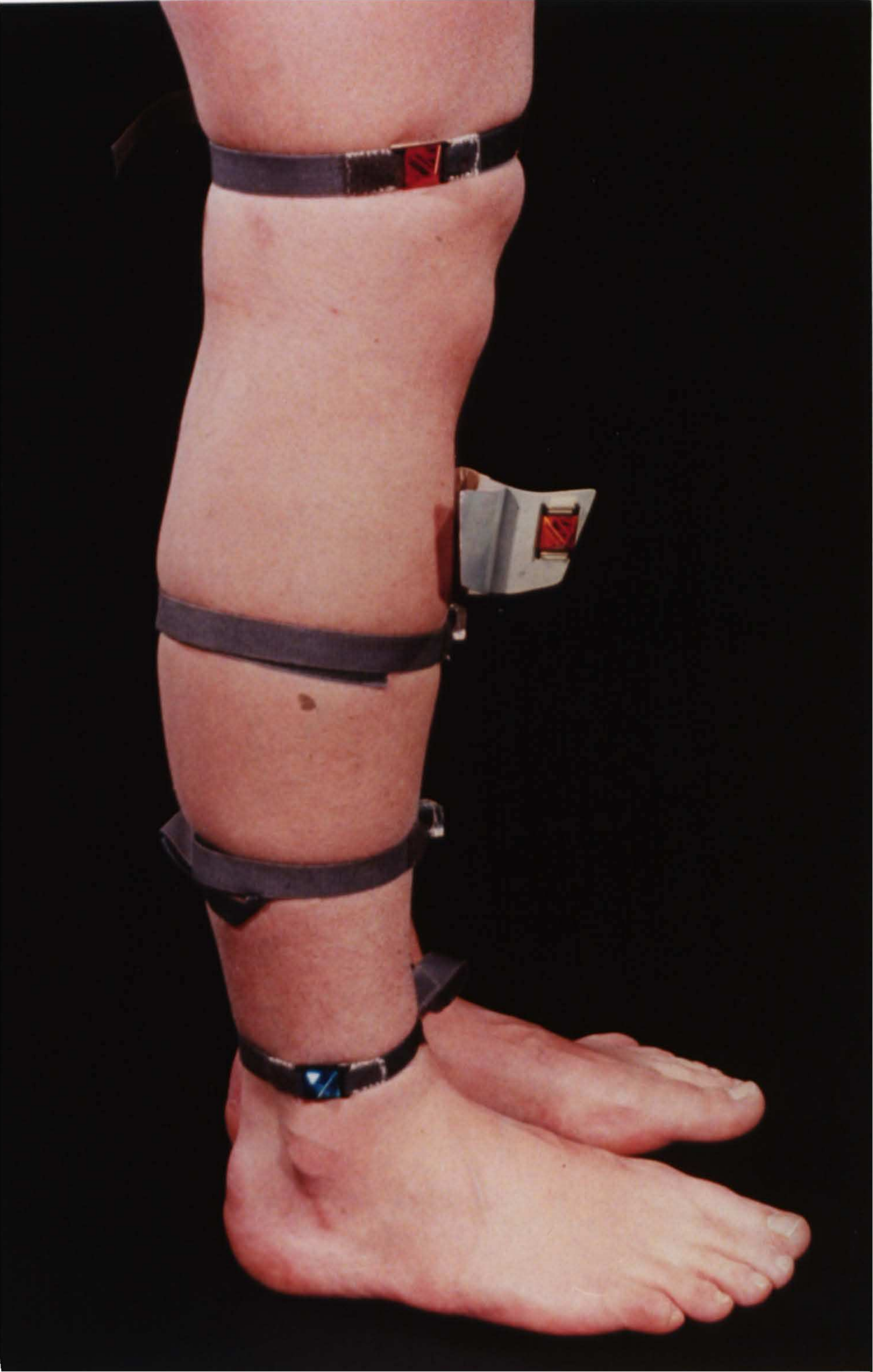

SURFACE LANDMARKS OF THE LOWER LEG  
WITH PLATE IN SITU.

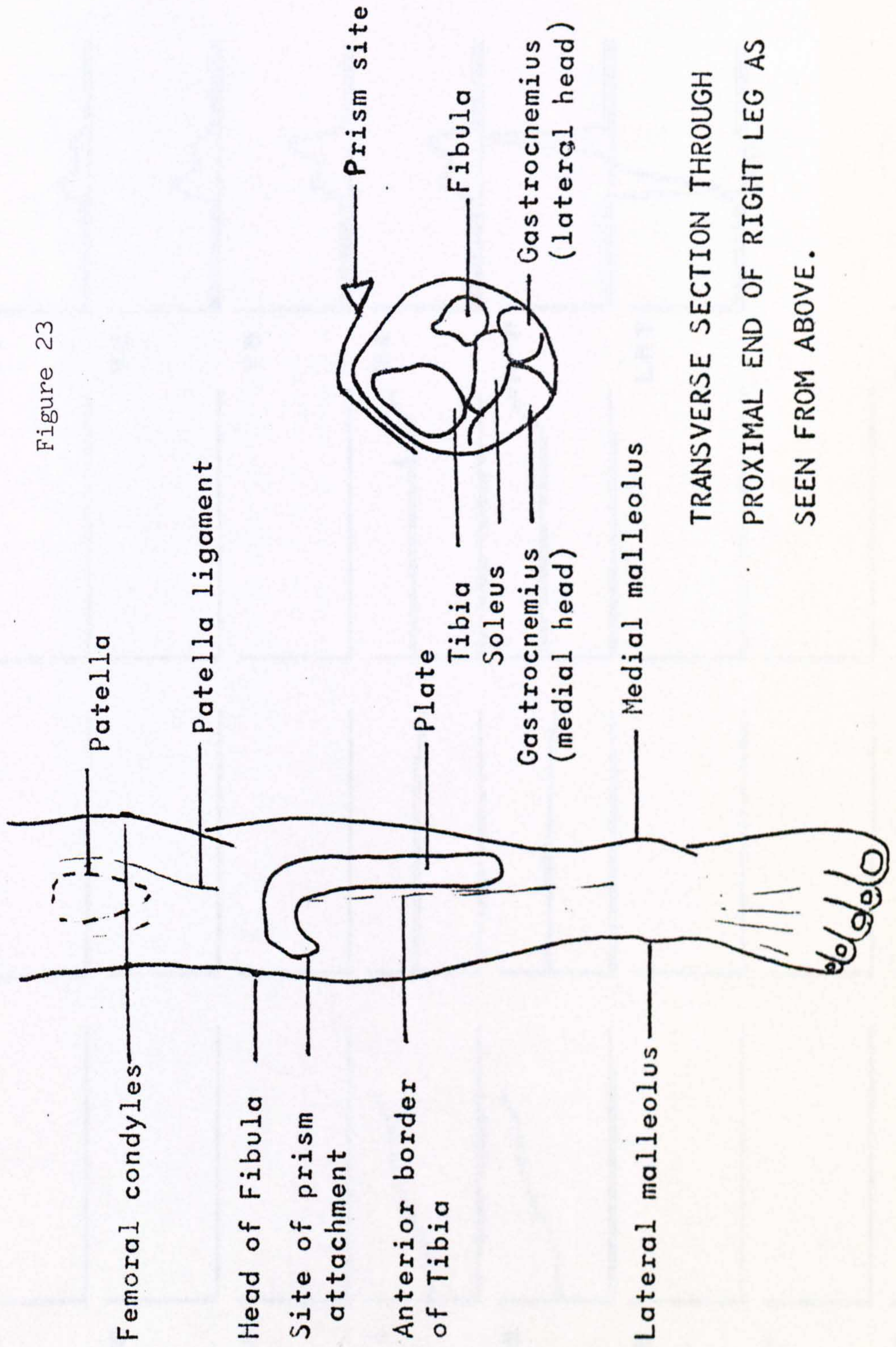
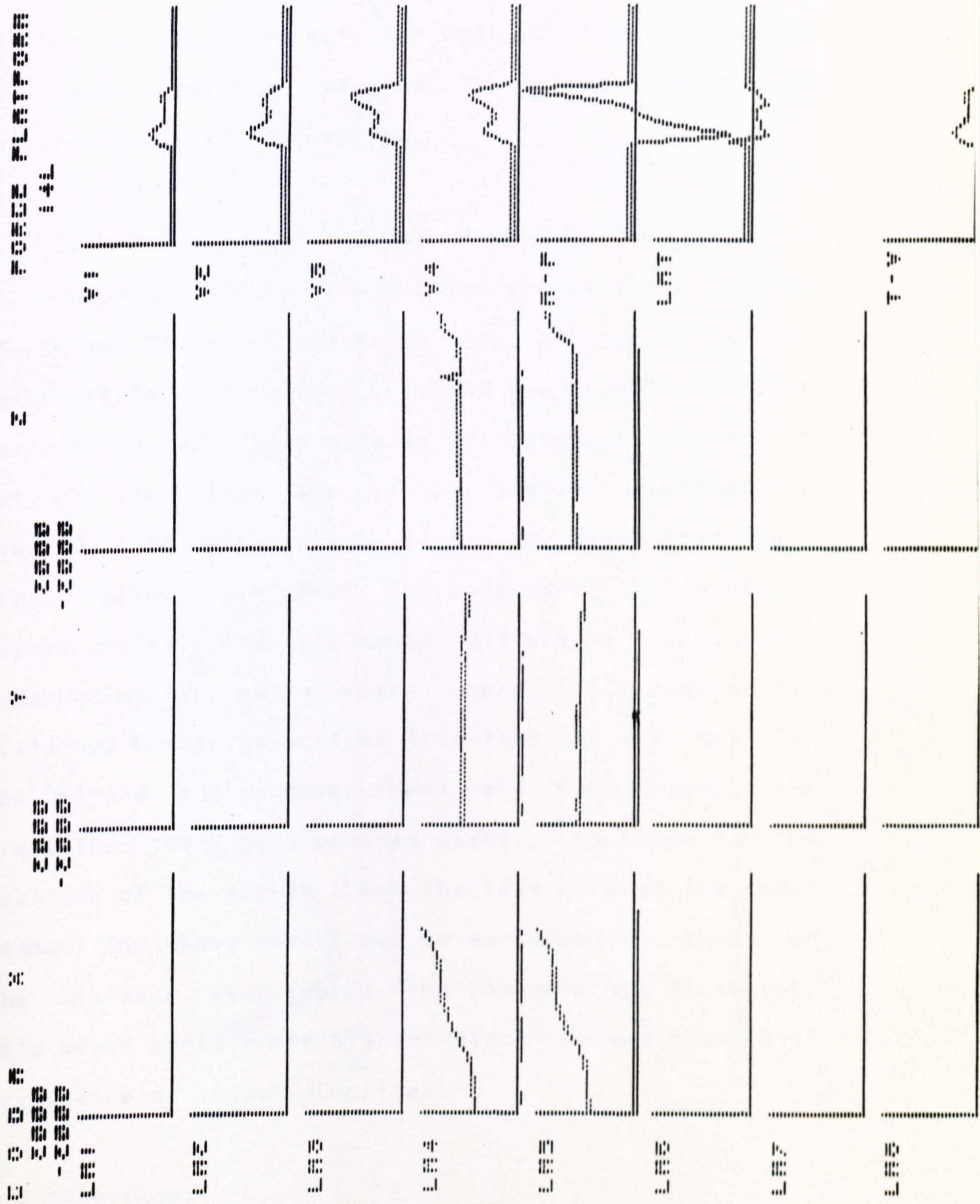

Figure 23

TRANSVERSE SECTION THROUGH  
PROXIMAL END OF RIGHT LEG AS  
SEEN FROM ABOVE.

Figure 24 Raw data from landmarks on the head of the fibula (4) and tibial plate (5).



fibula and landmark 5 is mounted on the plate). is similar in all respects for both locations. However the poor resolution of the TV screen limits our interpretation of the results.

2. The velocity profiles of the two landmarks in all three directions were plotted out as shown in Figs 25, 26 and 27. (FP identifying the antero-posterior force plate information). Once again cross conflict has occurred, and those data points associated with an out of view line are to be treated sceptically. Bearing in mind this point, it can be seen that both plots follow very much the same course, with slight discrepancies. The only major difference is in the y-direction in swing phase where the marker on the plate has higher velocities than that on the head of the fibula and produces these velocities later in the cycle than the fibula mounted marker. Considering the location of the marker along the long axis of the lower segment the above result can be explained in terms of the distance over which the landmark has to travel. This would explain the higher velocities and the later occurrence of these velocities.

### 3.4 Inferences

In the x and z directions we can justify mounting a marker away from the bulk of the leg, on a plate as

Figure 25 VELOCITIES (X-DIRECTION).

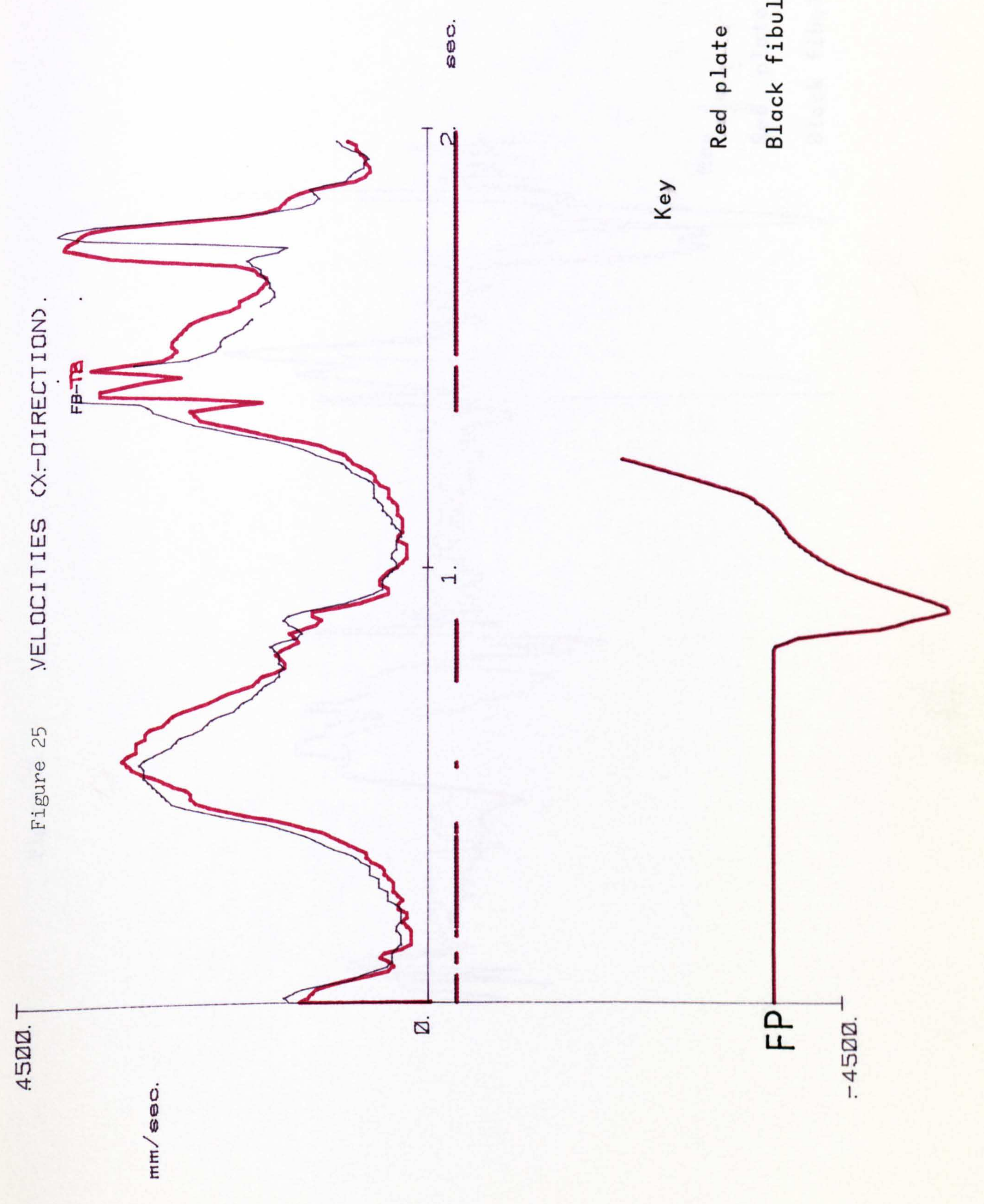

Key

Red plate

Black fibula.

2000. VELOCITIES (Y-DIRECTION).

FB-TB

170185.  
170185.

mm/sec.

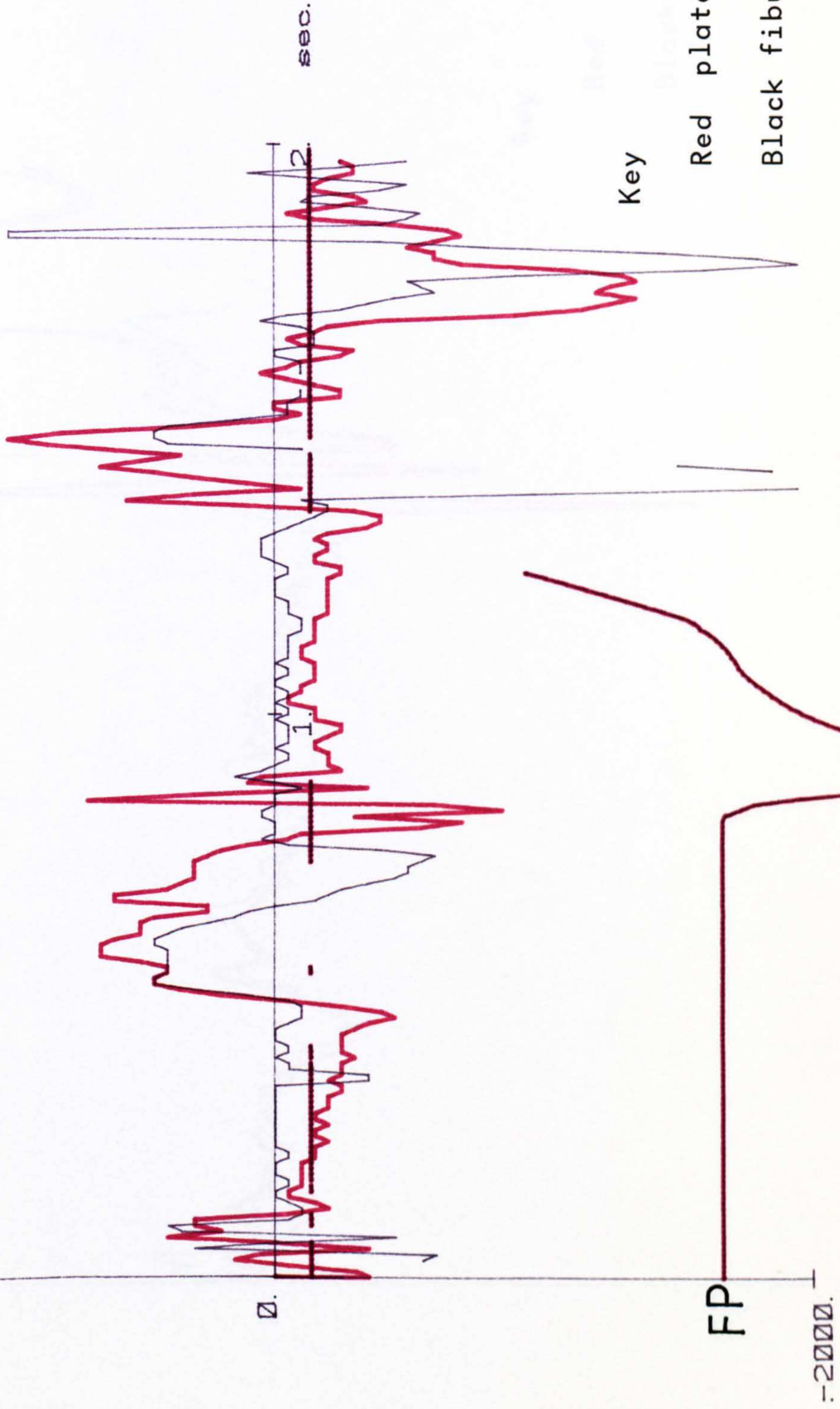

170185.00  
170185.90

Figure 27 VELOCITIES (Z-DIRECTION).

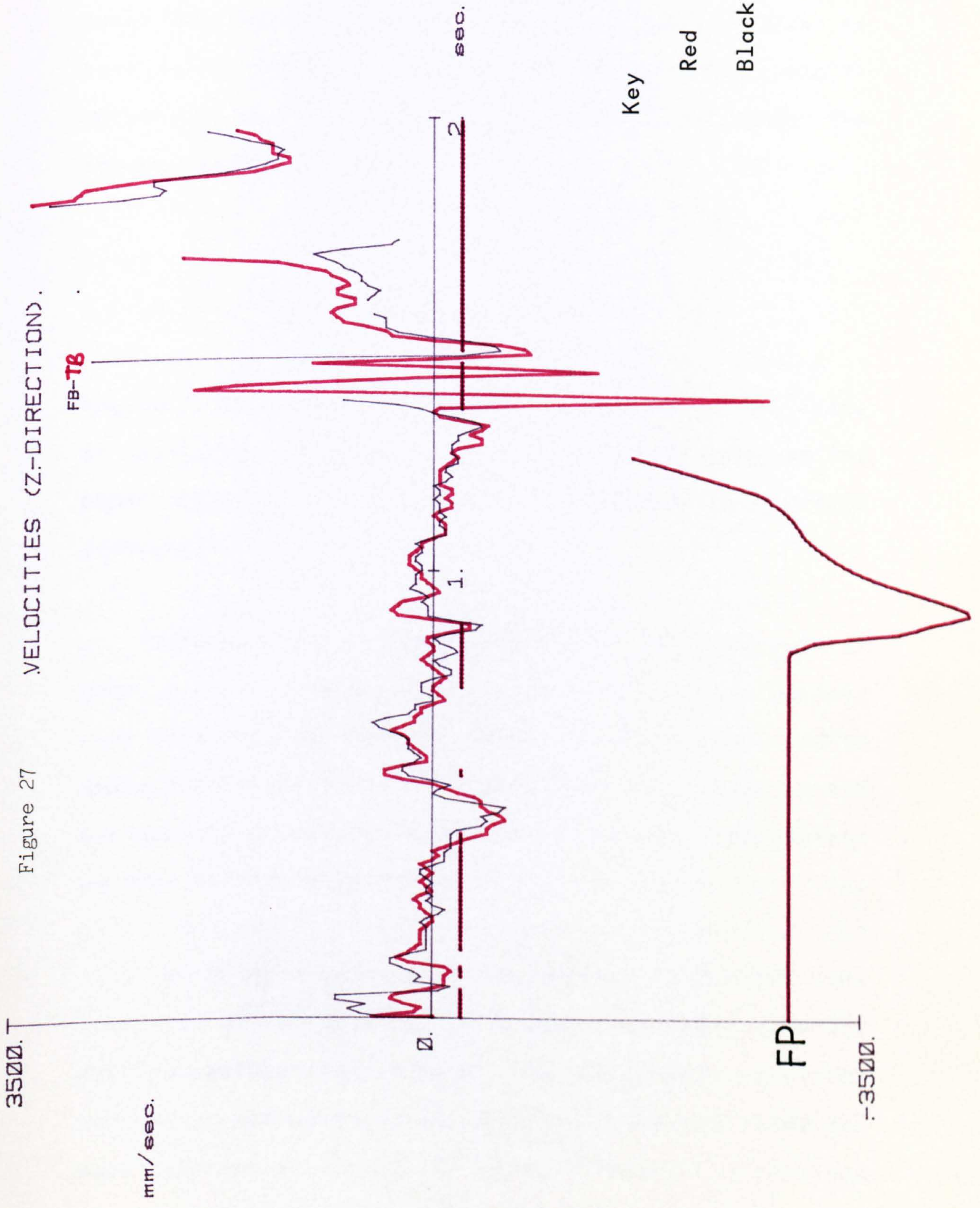

Key

Red

plate

Black

fibula

FP

-3500.



described above. In the  $z$  direction we would have to be aware of the discrepancy between the results obtained from the flatina method and those from the conventional mounting.

#### 4.0 Software development

The next section describes the development of a piece of software to determine the velocity profiles of the CODA-3 landmarks and the results obtained using this software.

Because of the problem of false data output by CODA during periods of cross conflict, it was decided that filtering of the data would be necessary. This would obviously have to be done with caution as we did not want to eliminate by filtering the very parameters we were hoping to measure.

The program written by the author calculates the velocity of up to eight landmarks over the two second data collection time. One by one the velocity profiles can be displayed as plots of velocity against time for each landmark in any of the three orthogonal directions or as a three dimensional velocity value. Combined with the velocity value is the out of view marker which aids in the discrimination of false from good data.

The incoming or stored raw CODA-3 data is firstly checked to see that they lie within reasonable limits of each other. By investigation it was decided that the reasonable limit would be defined as two data values lying within a multiple of times five of each other for all three directions. A second method of filtering the velocity data was by averaging the finite displacements over three consecutive data points. As stated above we had to be aware that this low pass filtering and averaging could lead to the exclusion of important information in terms of the kinematics of the knee joint.

#### 4.1 Testing

Very rough checks were made of the magnitude of the data by calculating the expected velocity profiles of landmarks mounted on the turntable described in an earlier chapter, and comparing these with the values obtained from the velocity software. Following on from this a comparison was made between velocity data generated by CODA-3 and that obtained by a cinematographic technique. The data used for comparison was that collected by Winter et al (1979).

Using the protocol described earlier a set of data was collected and used to plot velocity-time curves for several anatomical landmarks which had been used

previously by Winter in his study on the kinematics of normal locomotion. Certain differences exist between the two methods in so far as Winter looked at the velocities of centres of gravity of limb segments and not as with CODA-3 of defined anatomical landmarks. Table 20 highlights the similarities and differences between the two sets of data and gives the values of maximum and minimum velocities for two landmarks namely, the tibial tuberosity and lateral malleolus. With a knowledge of the location of the centres of gravity of the limb segments an extrapolation back to the anatomical landmarks can be made and conclusions drawn about the similarities between the two sets of data, other than just the maximum and minimum values.

To minimise energy expenditure during locomotion the excursions of the centres of gravity of limb segments should ideally be kept to a minimum. This theory is somewhat dated, i.e. the concept of playing off kinetic and potential energies more generally accepted. Hence we would expect the displacements for the centre of gravity of the shank to be midway between the displacements collected using CODA-3 for the lateral malleolus, head of fibula and tibial tubercle. The centre of gravity of the foot is located approximately 2 cm anterior to the ankle joint axis and 1 cm medial to the mid-line of the inferior surface of the calcaneus. That of the calf is located at

COMPARISON OF CODA-3 AND TV DATA.

TV

CODA-3

- |    |   |   |
|----|---|---|
| 1. | Centre of gravity plots                                 | Anatomical landmark plots                     |
| 2. | Anatomical landmark max/min                             | Anatomical landmark max/min                   |
| 3. | Precision to nearest mm                                 | Precision to nearest mm                       |
| 4. | Low pass filtering of raw data                          | Low pass filtering of raw data                |
| 5. | Plot over 1.8 secs                                      | Plot over 2.0 secs                            |
| 6. | 109 data points   | 100 data points                               |
| 7. | Heel contact determined from a threshold velocity value | Heel contact determined from force plate data |
| 8. | Stride time 1.13 seconds                                | Stride time 0.87 secs                         |
| 9. | Approximate cadence 106                                 | Approximate cadence 138                       |

Maximum and minimum values. (cm/sec)

Tibial tuberosity:

	Maximum	Minimum	Maximum	Minimum
dir.	244	-15	310	-25
dir.	49	-34	50	-30

Lateral malleolus:

	Maximum	Minimum	Maximum	Minimum
dir.	346	0	430	-5
dir.	105	-120	70	-95

1. Average of eight subjects

One subjects data.

approximately mid-shaft.

#### 4.2 Results

Firstly the plots of the centre of gravity velocities versus time will be compared with the plots drawn-up by CODA-3 (ie anatomical landmark velocities). Secondly comparison of the published results (Winter et al 1979) of the maximum and minimum velocities for tibial tuberosity and lateral malleolus will be made with those calculated by CODA-3.

#### The foot

For comparative purposes the traces obtained from CODA-3 for the lateral malleolus will be looked at in conjunction with those of the centre of gravity of the foot.

Looking first at the x-direction velocities, the two plots have a similar overall shape and similar maximum values. In both this maximum occurs just prior to heel strike, with however the centre of gravity velocity having a steeper gradient (ie acceleration) prior to and following peak velocity. In both, after heel strike, there is a small rise in velocity of approximately 1/20 th of maximum velocity, less obvious

in the CODA-3 plots than in the centre of gravity plots.

The maxima and minima values (Winter 1979) given for the velocities in the x-direction for the lateral malleolus are much the same as those determined by CODA-3.

The y-direction plots again exhibit the same maxima and minima pattern with heel strike being immediately preceded by the second maximum in both plots. The timings of the maxima and minima velocities on both plots are again in close agreement, however CODA-3 shows a higher maximum value on the plots than does Winter's work (91 cm/sec compared with 60 cm/sec, the second peaks being of similar magnitude).

The maxima/minima values for the velocities in the y-direction for the lateral malleolus cover a larger range in Winter's results than in CODA-3's results (amounting to an approximate 30% decrease).

#### The Shank

For comparative purposes the traces obtained from CODA-3 for the head of the fibula will be looked at in conjunction with those of the centre of gravity of the calf, compiled by Winter (1979).

Those velocities for the tibial tubercle by the CODA-3 method are much the same as those for the head of the fibula and will not be discussed separately.

In the x-direction both plots exhibit a peak velocity at approximately 75% of the gait cycle of similar magnitude, both also have another increase in velocity after heel strike again of similar magnitude. As with the foot both peaks are more acute, ie. have higher acceleration values, in Winter's work than in our results using CODA-3.

Only maxima and minima values (Winter) for the tibial tubercle are available for comparison, but as stated earlier results from CODA-3 for the head of the fibula and tibial tubercle are very similar. Again the two sets of velocities for the tibial tubercle are in close approximation, the largest difference being seen in the positive x values where CODA-3's maximum is 27% higher than that of Winter's.

In both of the y-direction velocity plots prior to heel strike there are two peak values of similar magnitude. For the CODA-3 method the values are approximately + and - 40cm/sec, and for Winter's they are approximately 25 cm/sec. CODA-3's velocities plateau after heel strike whereas this is less evident in Winter's work, although the rise to peak positive

velocity has a similar gradient.

Once again maximum/minimum  $y$ -direction velocities are within a few units of one another when comparing the two methods.

#### 4.3 Discussion and Inferences

For both areas of the lower limb segments studied the anatomical landmarks tracked lie proximal to the segment centre of gravity. In the foot the landmark chosen i.e. the lateral malleolus, lies approximately 4cm lateral and 3cm posterior to the foot's centre of gravity. Likewise with the calf, the tibial tubercle and head of fibula lie proximal to the centre of gravity of that segment which has been determined to be at approximately mid-shaft.

Points lying away from the centre of gravity of a limb segment would be expected to have larger fluctuations in displacement than the corresponding centre of gravity, which the body attempts to keep to a minimum as regards displacement to reduce the amount of energy expended.

Winter (1979) showed a non-linear relationship between derivatives of displacement and cadence. The difference between the  $x$ -direction velocities for the



two sets of data might well be accounted for by the difference in cadence of the two groups (ie CODA-3's subject is thought to have had a higher cadence than those in Winter's study). Likewise in the  $y$ -direction the difference may be put down to differences in speed of locomotion.

A second explanation may be that as CODA-3 is looking at anatomical points proximal to the centre of gravity it could be picking up on the larger excursions we might expect to find. With the foot marker, inversion and eversion would certainly cause the lateral malleolus to undergo greater displacements in the vertical direction than the centre of gravity, leading to higher velocities for the lateral malleolus (compared with the centre of gravity of the foot). This will lead to differences in the velocities generated by this landmark compared with that of the centre of gravity of the foot. Another example is that at heel strike, where the landmark on the lateral malleolus remains in a fairly fixed position whereas the point at which the centre of gravity of the foot is located moves through an arc as the foot is brought into contact with the floor. This generates a high negative velocity at heel strike, which is less evident in the trace obtained from the landmark on the lateral malleolus. Likewise as the foot leaves the ground the positively directed  $y$ -direction velocities are seen for

the lateral malleolus, but lower velocities are generated by the centre of gravity of the foot.

Timing of events in the gait cycle seems to be fairly consistent between these two sets of data and the velocities calculated by the two methods are comparable. No statistical analysis has been attempted because of the small sample sizes.

## 5.0 Reproducibility and Speed effect on Velocity Profiles

As a follow on from the comparative study, and prompted by Winter's observations, a study was made of the reproducibility of and the effect of speed upon the velocity/time traces for landmarks sited on the head of the fibula and the lateral femoral epicondyle. These two sites were chosen as it had been decided that a good indicator of joint condition might be the difference in kinematic characteristics of the two areas directly above and below the knee joint, where any joint laxity might be accommodated.

### 5.1 Method

Using the set protocol, with the landmarks sited as described, data were collected from two female

volunteer subjects for one at her natural walking speed and the other at three speeds termed loosely, slow, medium and fast. For the first test the velocities were plotted against time on the Hewlett Packard plotter, three runs for the landmark on the head of the fibula and two for the one on the lateral epicondyle. For the second test nine traces again output on the plotter were overlaid corresponding to the three runs for each of the three speeds. For all plots the antero-posterior force data (from the Kistler force plate), were plotted with the velocities to allow definition of the stance phase. All traces started at heel strike. From the x-direction plots the stance and swing times of the gait cycles have been calculated and repeatability has been assessed by eye because of the very small numbers involved.

## 5.2 Results

Figures 28 to 33 show the repeatability of gait in the three directions for the two landmark sites, (also showing the force plate trace). For both sites and all directions the curves are amazingly congruent particularly when the time difference between curves is taken into account. The only (non statistically) significant difference between the curves is seen in the z-direction for the fibula at toe off where the magnitude of velocity of one of the curves is

Figure 28

VELOCITIES (X-DIRECTION).  
RIGHT FIB

4500.

mm/000.

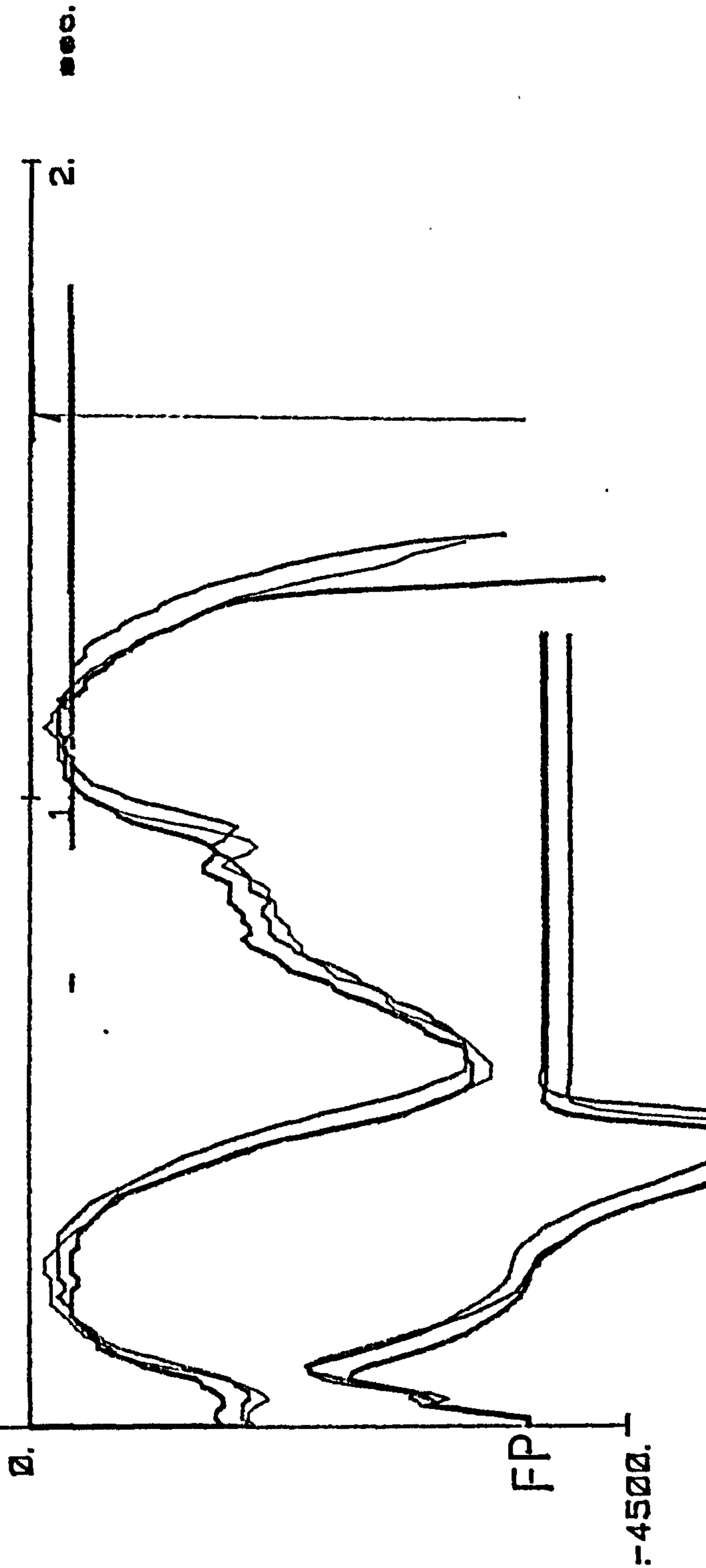

310785. MD  
310785. MD  
310785. MD

Figure 29

VELOCITIES (Y-DIRECTION).

RIGHT FIB .

310785. MO  
310785. MO  
310785. MO

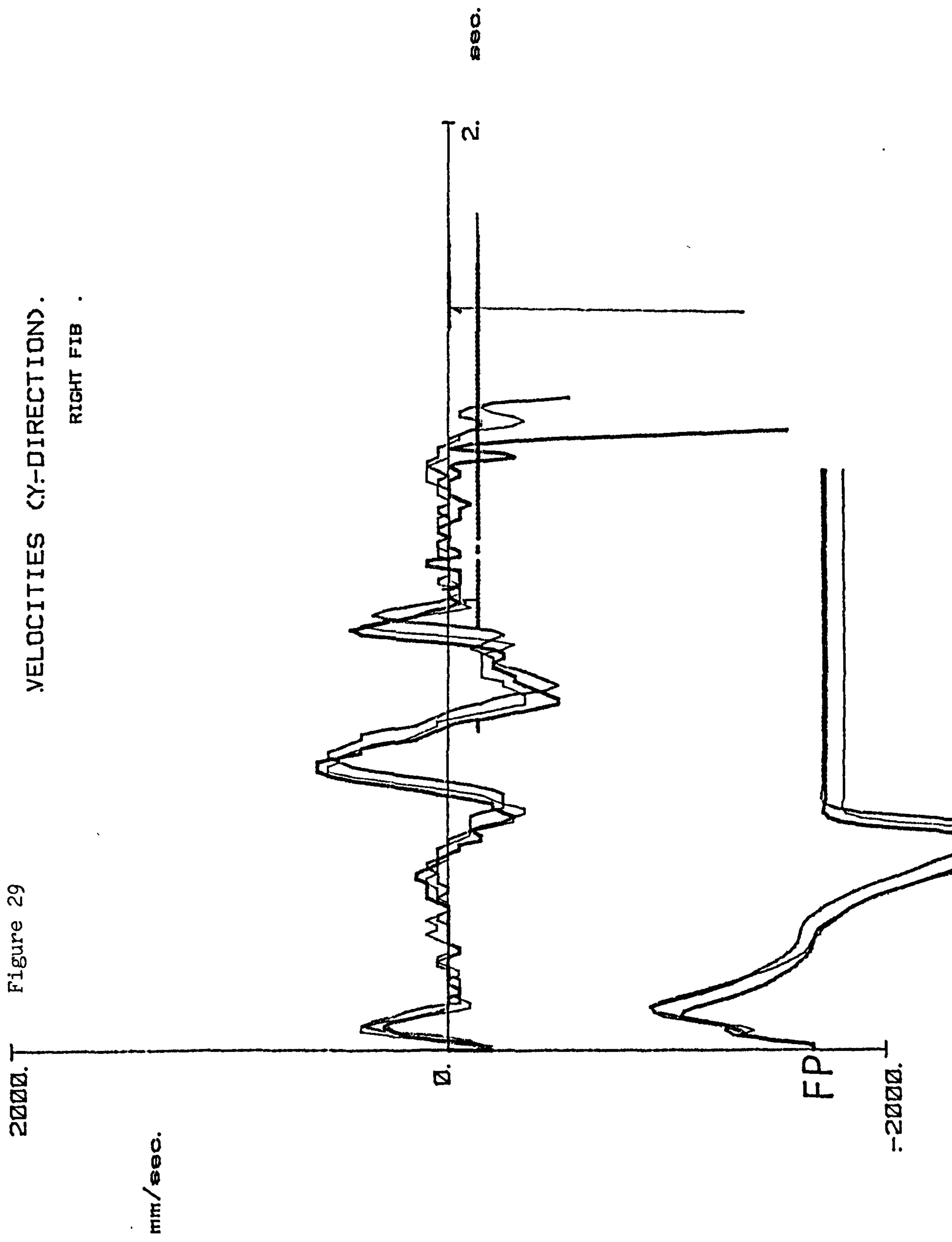

mm/sec.

sec.

FP

-2000.

Figure 30

VELOCITIES (Z-DIRECTION).

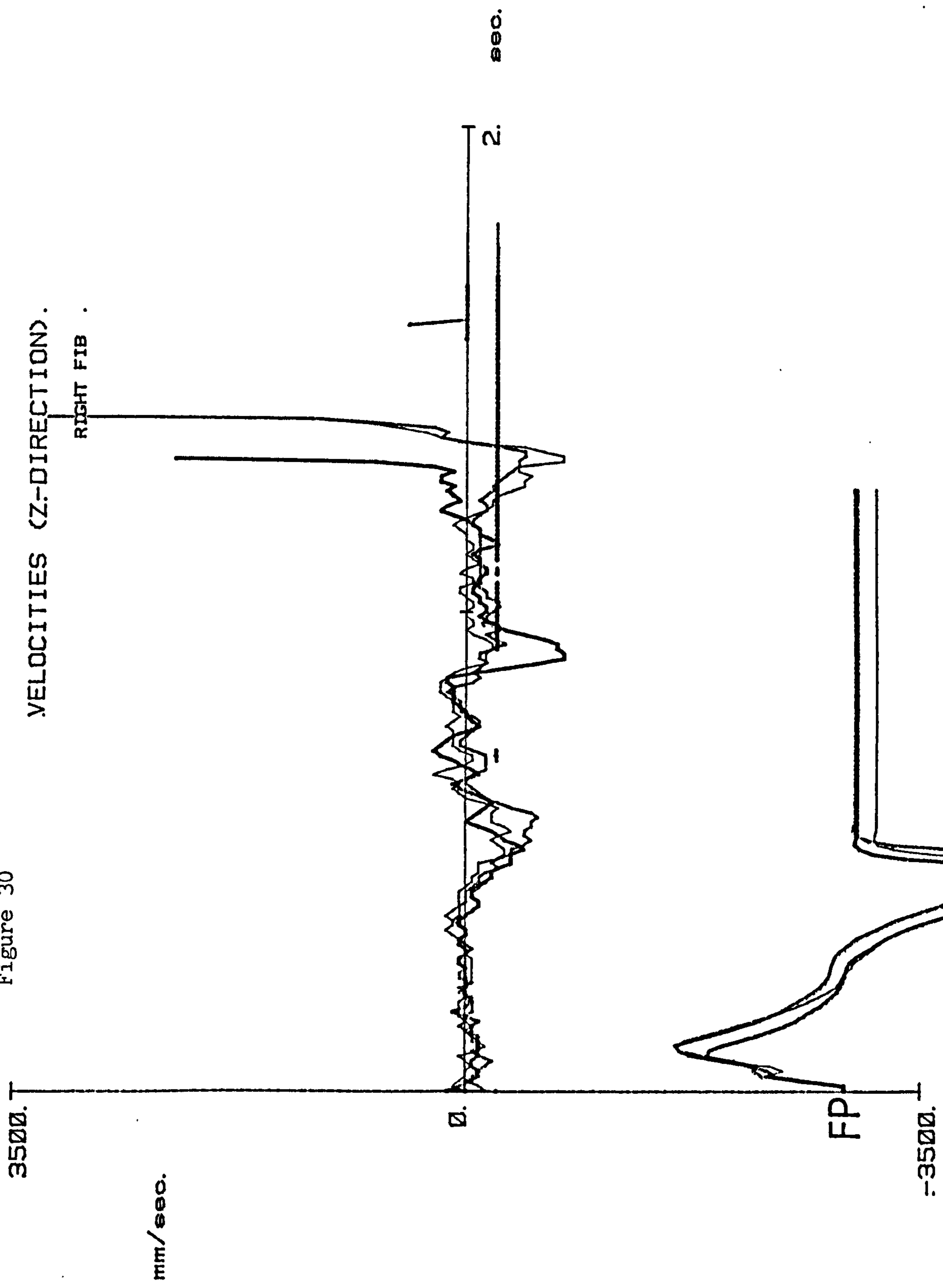

310785. MO  
310785. MO  
310785. MO

Figure 31

VELOCITIES (X-DIRECTION).  
RIGHT FEMUR.

4500.

mm/sec.

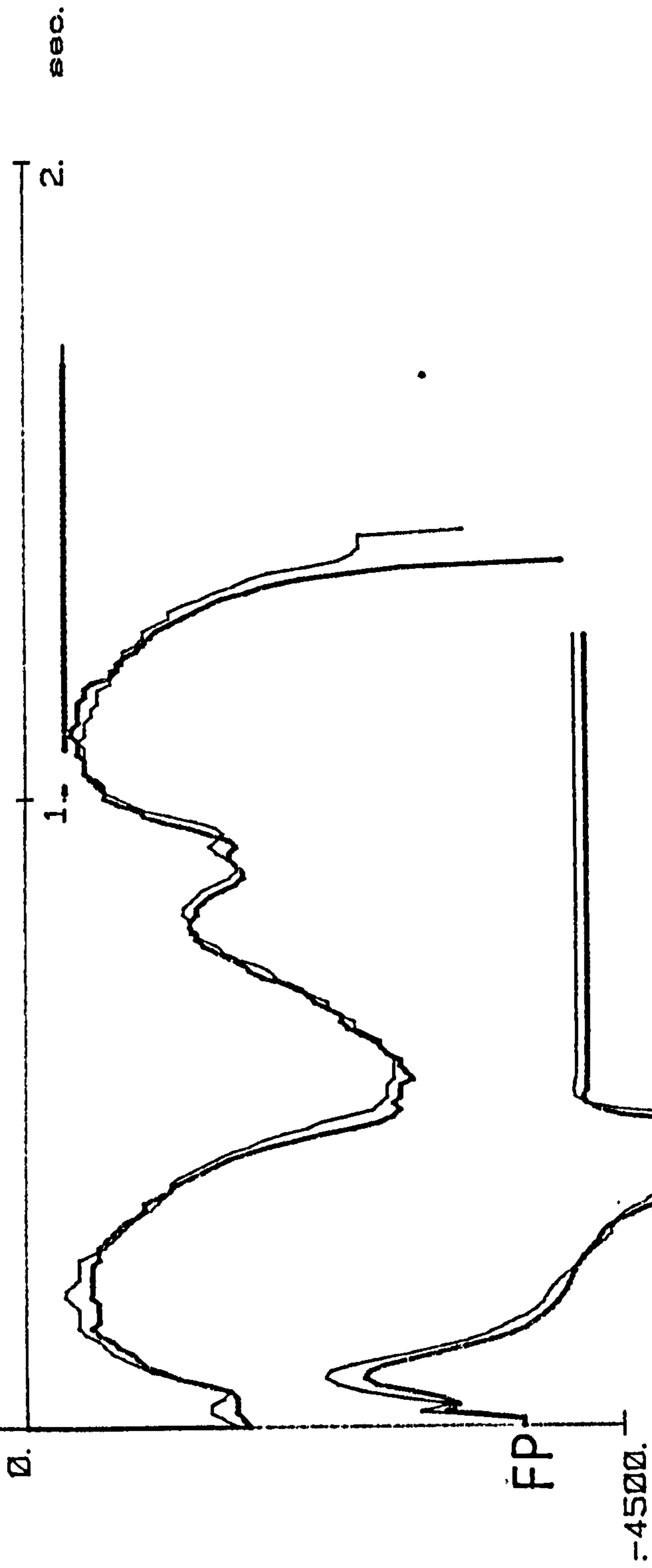

310785. MO  
310785. MO

Figure 32

VELOCITIES (Y-DIRECTION).

RIGHT FEMUR.

2000.

mm/sec.

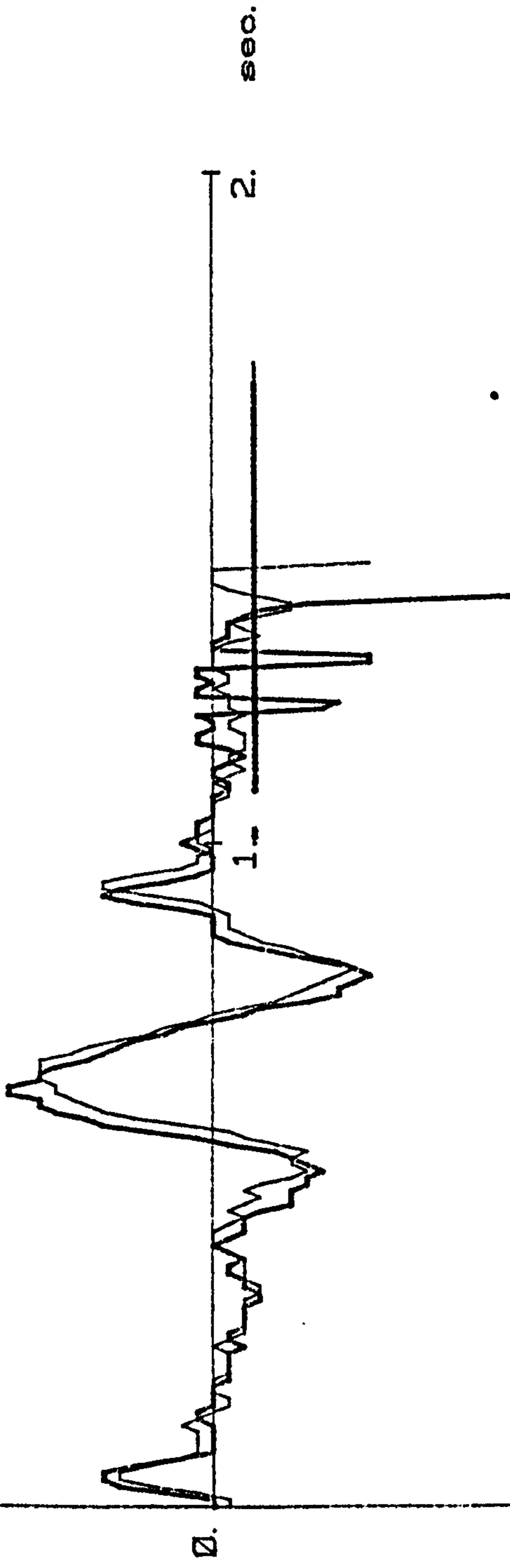

FP

-2000.

310785. MO  
310786. MO



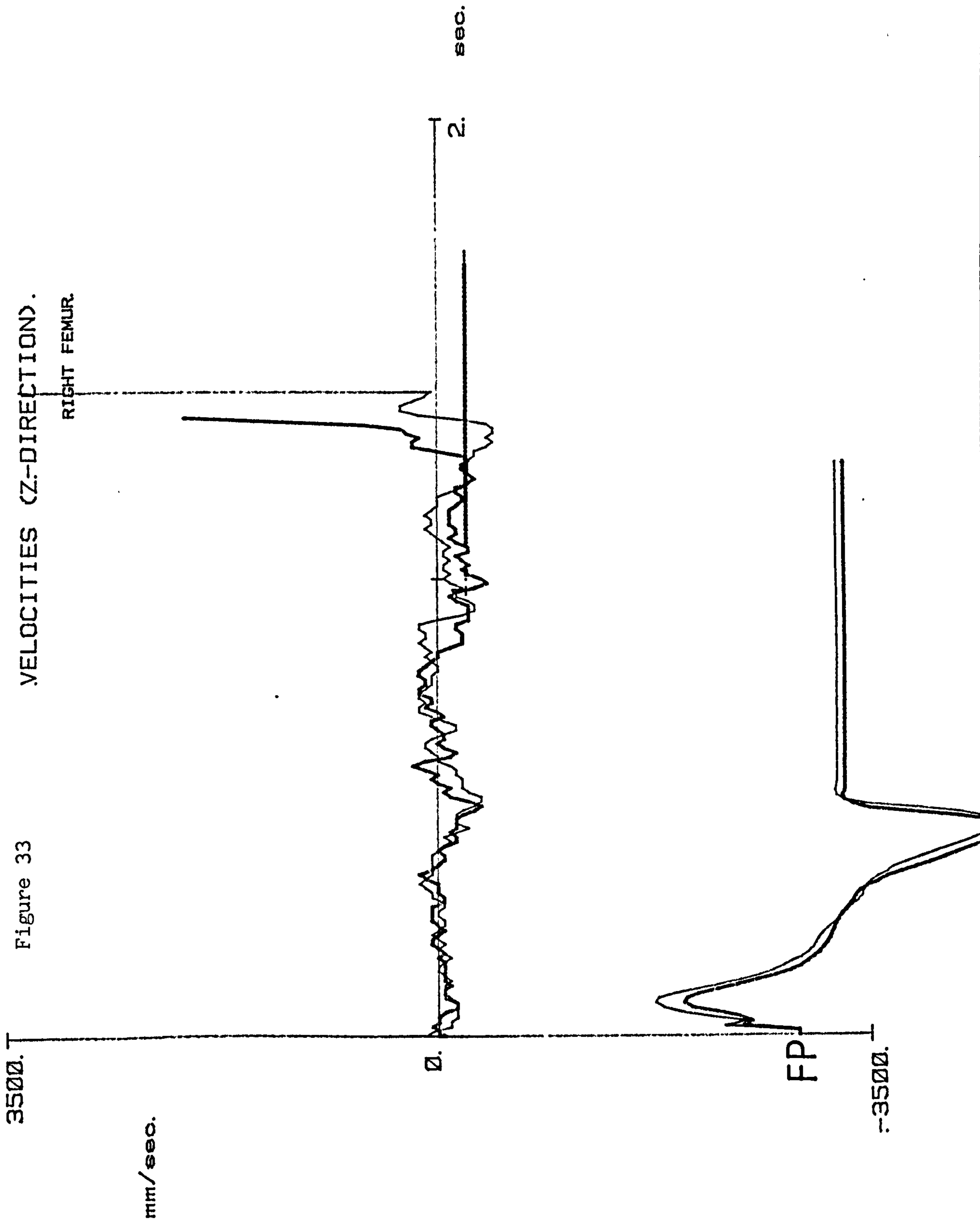

Figure 33

VELOCITIES (Z-DIRECTION).  
RIGHT FEMUR.

310785. MO  
310786. MO

3500.

mm/sec.

0.

2.

sec.

FP

-3500.

considerably higher than that of the other two. Because of the need to overlay directly comparable parts of the gait cycle all the traces had to start at heel strike and hence data have been apparently lost. This is not the real case, and the traces shown are typical of all the traces recorded. Several other subjects unfamiliar with gait analysis were put through the same procedure and again their velocity/time plots were much the same for each test run but slightly different in finer detail from other subjects.

It would be expected that the patterns produced from an unsound limb would have their own characteristic pattern brought about by the constraints of the joint condition. This idea will be investigated in detail later but at present we are concerned with a description of the overall patterns seen in the normal velocity profiles.

Figures 34, 35 and 36 defines the phases of the gait cycle and relates them to the velocity profiles. This is obviously a schematic representation and does not take into account the intersubject variations. It allows the observer to assess the gross deviation from the normal by referencing back to these diagrams. In further experiments these diagrams were used to pick out deviations and then relate them to the clinical findings.

4500. VELOCITIES (X-DIRECTION).  
mm/sec.

mm/sec.

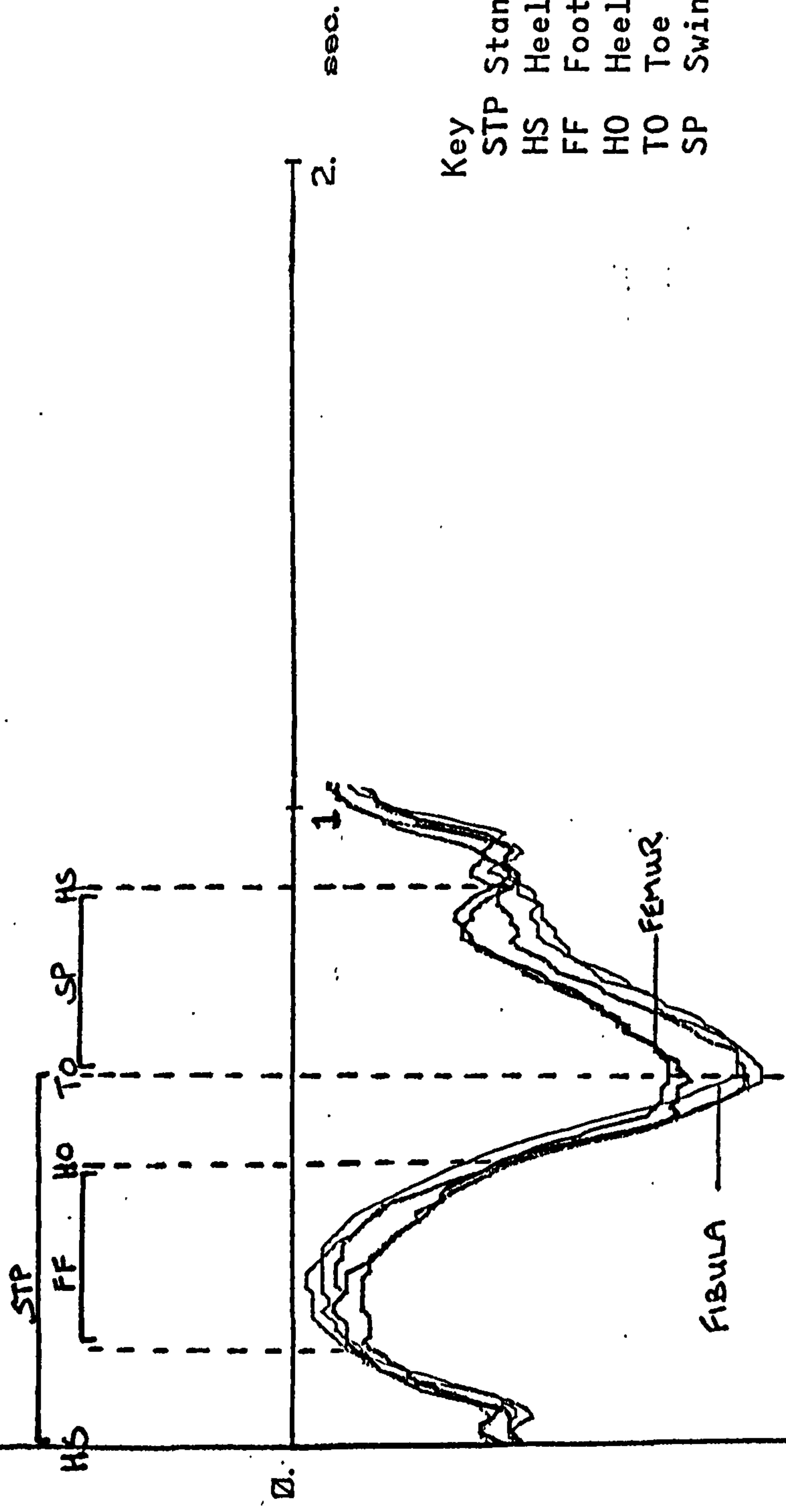

0. 1. 2. sec.

- Key
- STP Stance phase
  - HS Heel strike
  - FF Foot flat
  - HO Heel off
  - TO Toe off
  - SP Swing phase

Figure 34

-4500.

VELOCITIES (Y-DIRECTION)

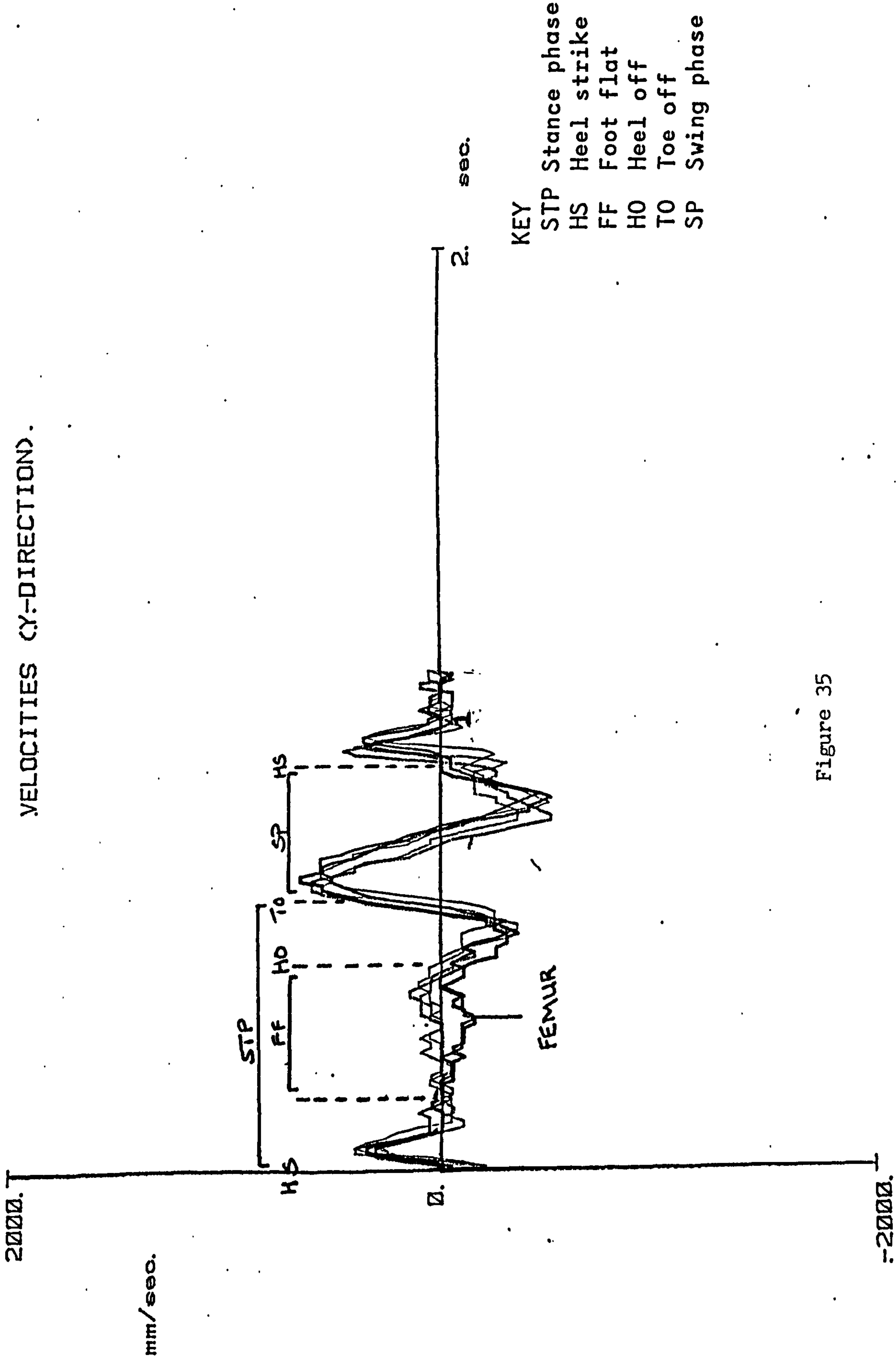
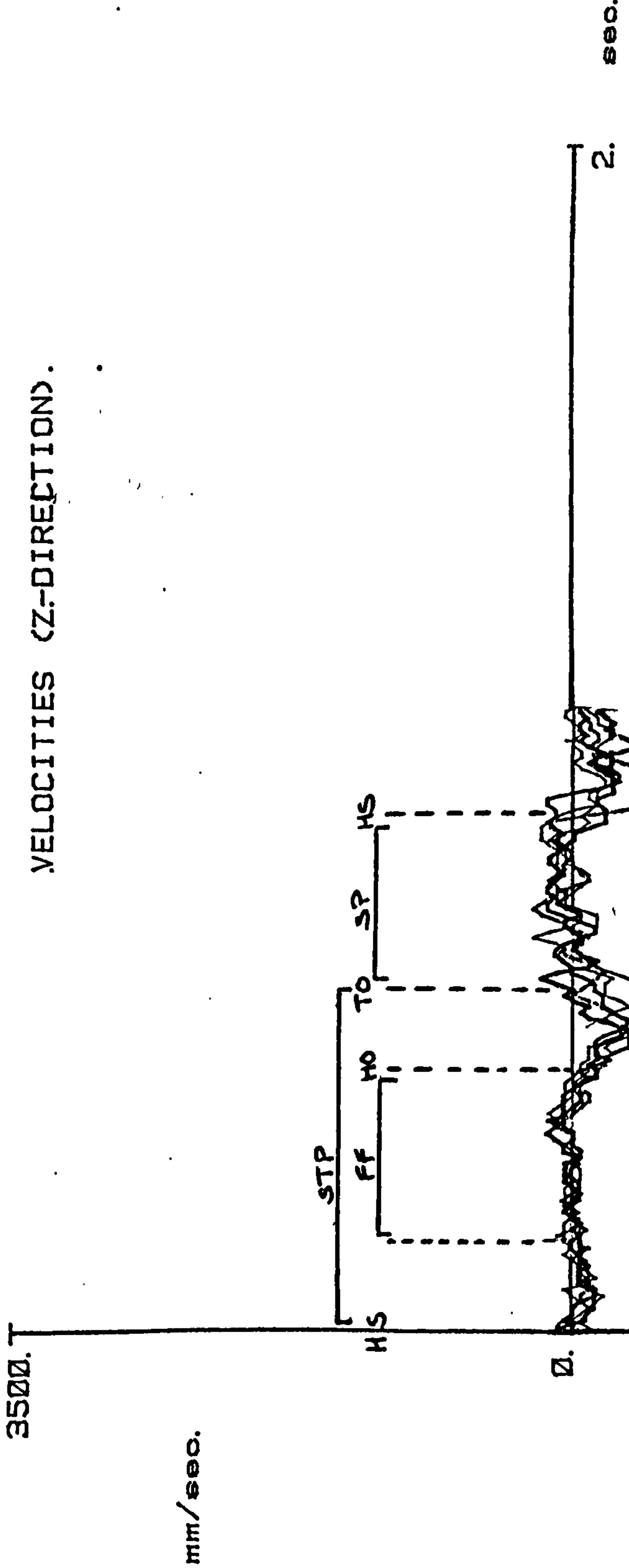

Figure 35

VELOCITIES (Z-DIRECTION).



KEY  
 STP Stance phase  
 HS Heel strike  
 FF Foot flat  
 HO Heel off  
 TO Toe off  
 SP Swing phase

Figure 36

Figures 37 to 42 show the traces in the three directions for the three speeds of locomotion. Table 21 shows the averaged times for the phases of the gait cycle, which allows assessment of how the components of gait contribute towards increase in speed of locomotion. For each direction the pattern of the velocity profiles changed with increasing speed in quite an obvious fashion. Changes in the velocity profiles with change in speed of locomotion are briefly described, bearing in mind the inevitability of intrasubject variation, which it is hypothesised would become more evident as constraints are applied to the individual.

In the x-direction (line of progression), as would be expected, with increased speed of locomotion, both the swing and stance phases are shortened. Along with this the amplitude of the maximum velocity in swing phase increases with increased speed of travel. In the early shock absorptive phase of stance, the maximum forward directed velocity for the femur increases proportionately more with increased speed than that of the fibula. That is, the x-direction velocity of the distal part of the femur in early stance is more dependent upon speed of locomotion than is that of the proximal fibula. However, overall the shape of the curves remains very similar whatever the speed of walking.

VELOCITIES (X-DIRECTION).  
RIGHT FIB.

150885. JA  
150885. JT  
150885. JT

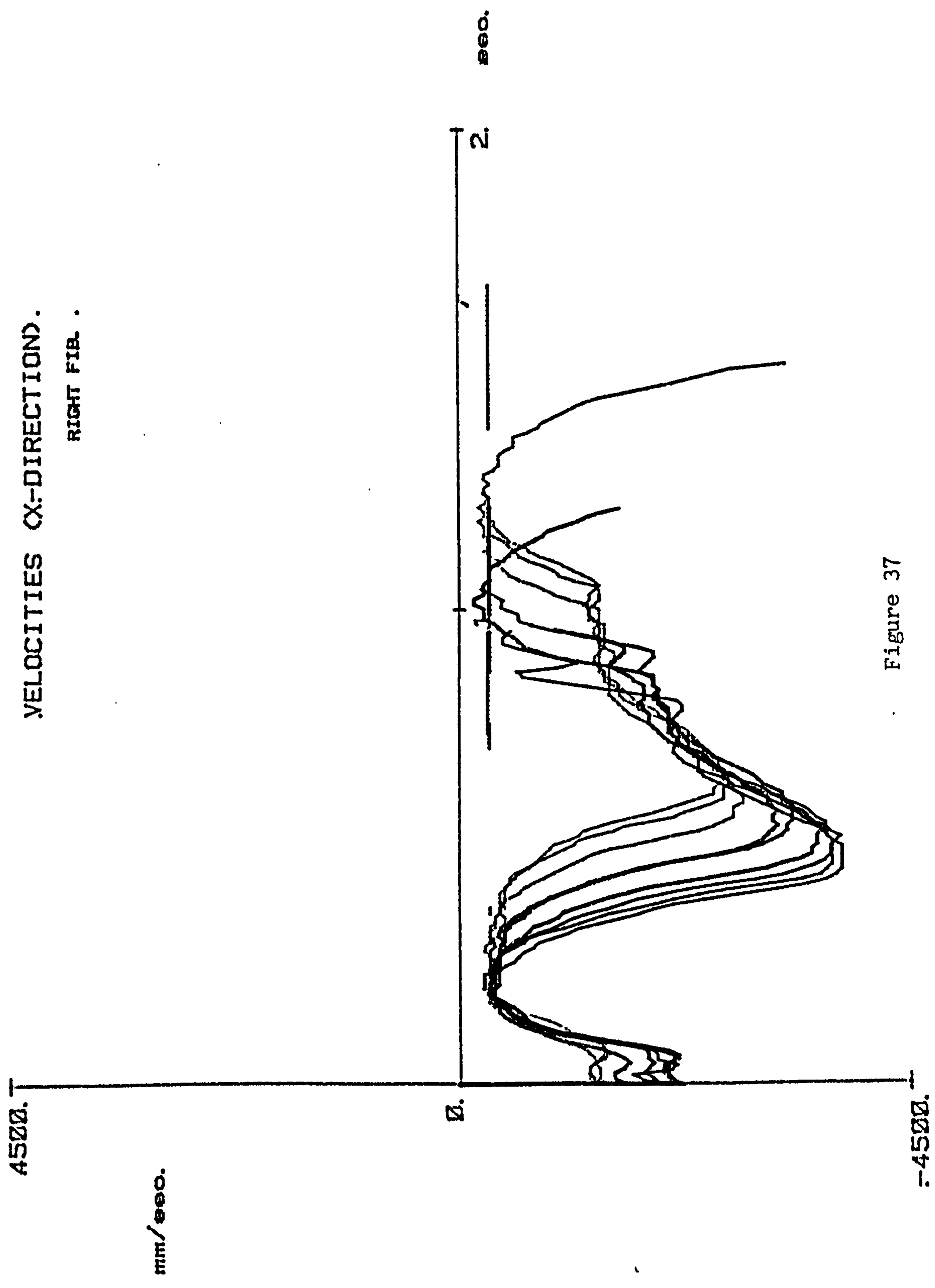

Figure 37

VELOCITIES (Y-DIRECTION).  
RIGHT FIB.

150985. JA  
150985. JT  
150985. JT

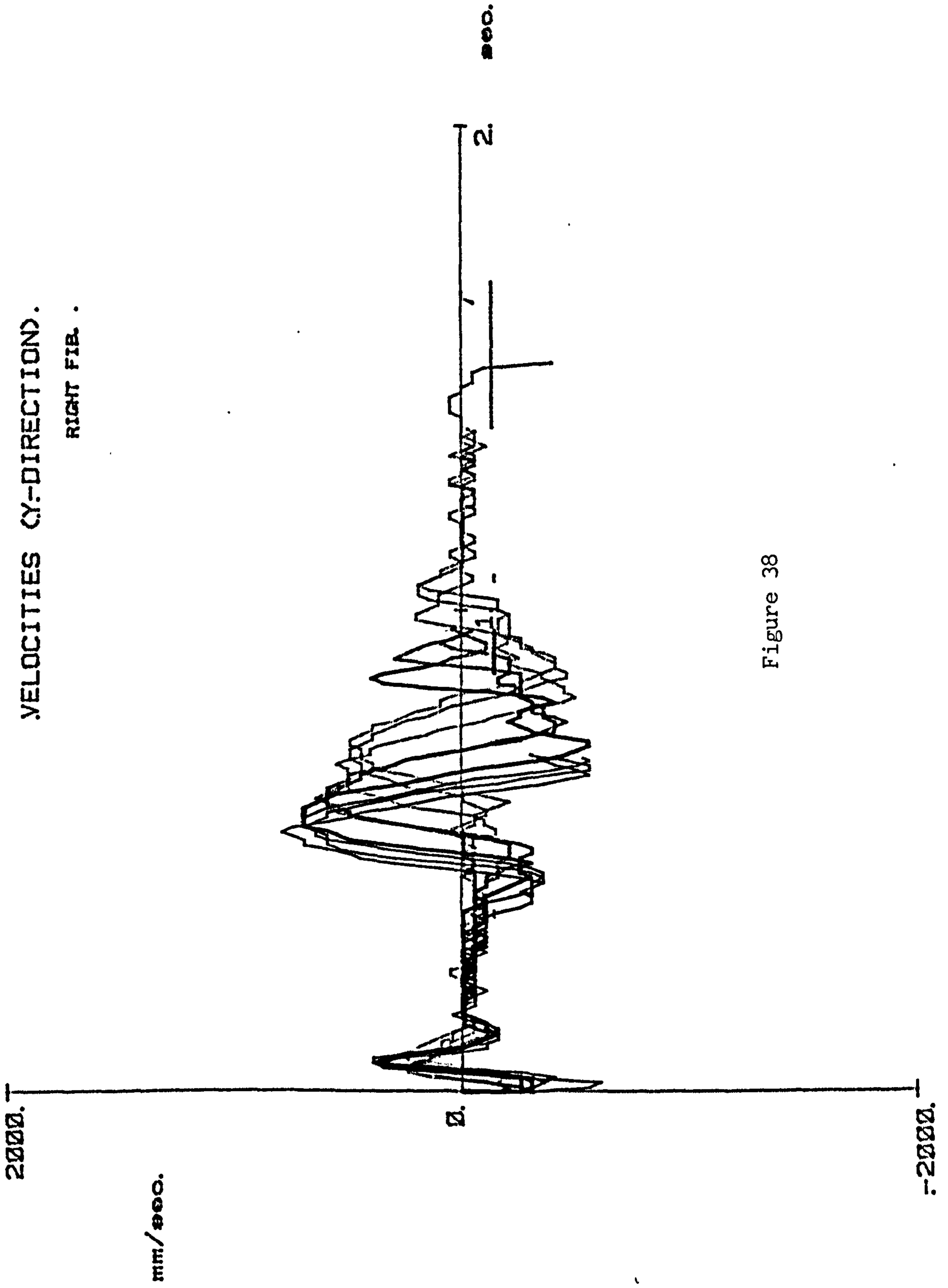
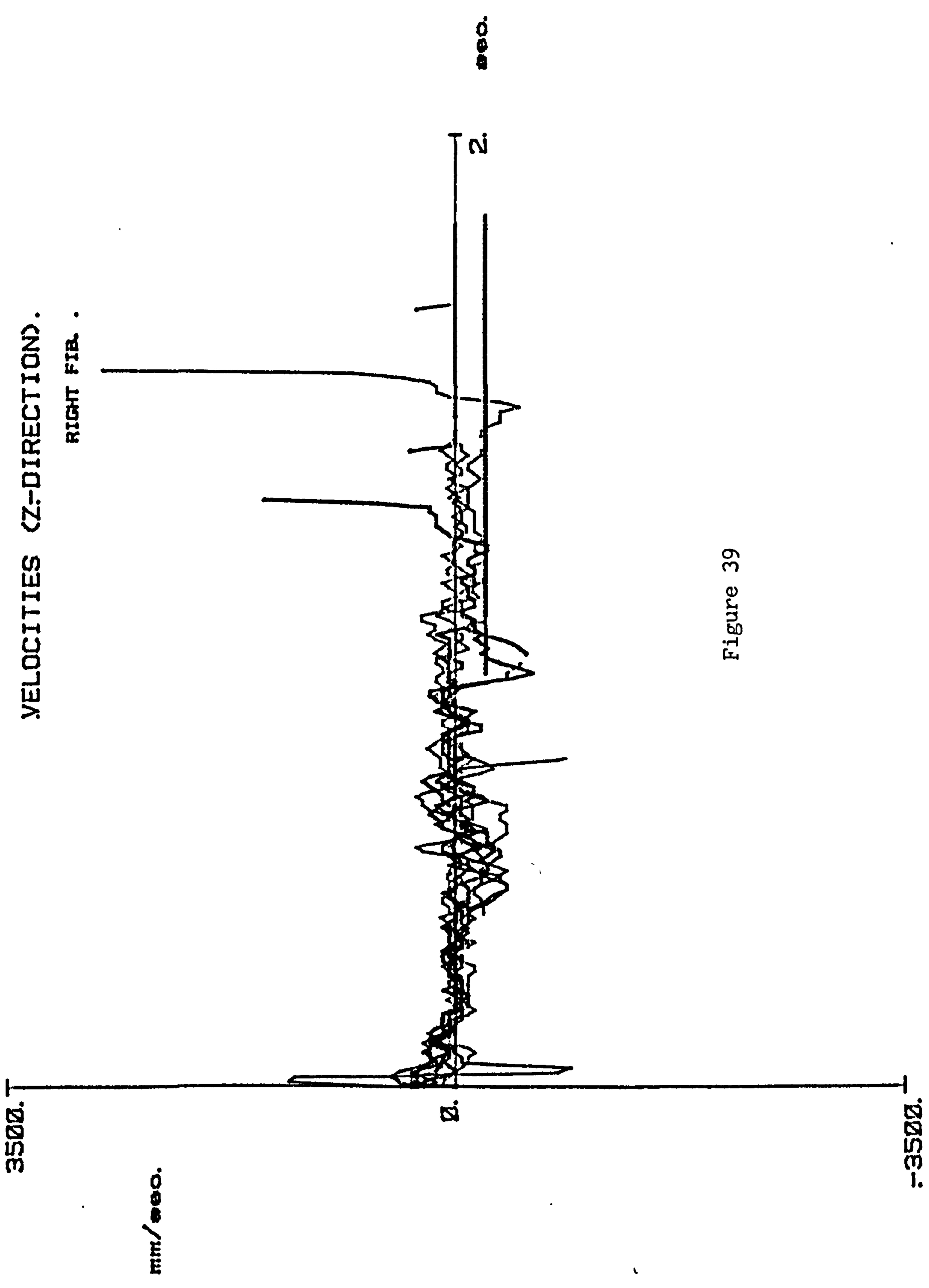

Figure 38





150005. JA  
150005. JT  
150005. JT

Figure 39

4500.

VELOCITIES (X-DIRECTION).  
RIGHT FEMUR

150005. JT  
150005. JT  
150005. JT

mm/sec.

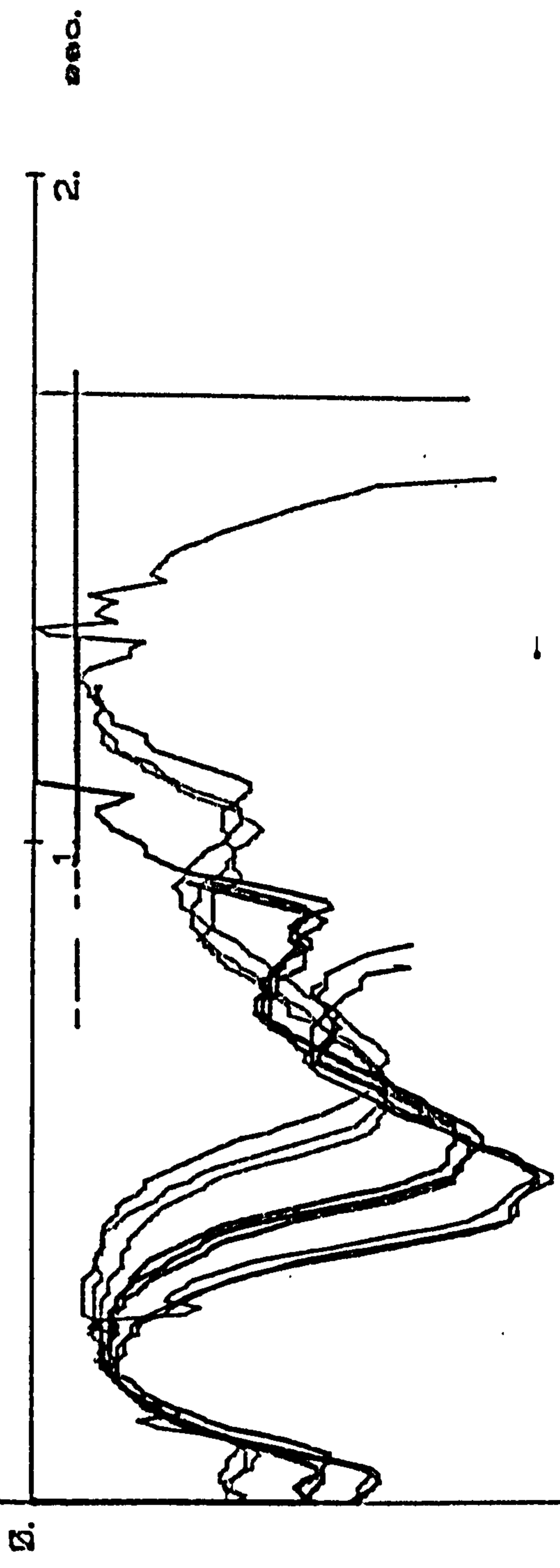

-4500.

Figure 40

VELOCITIES (Y-DIRECTION).  
RIGHT FEMUR.

150885. JT  
150885. JT  
150885. JT

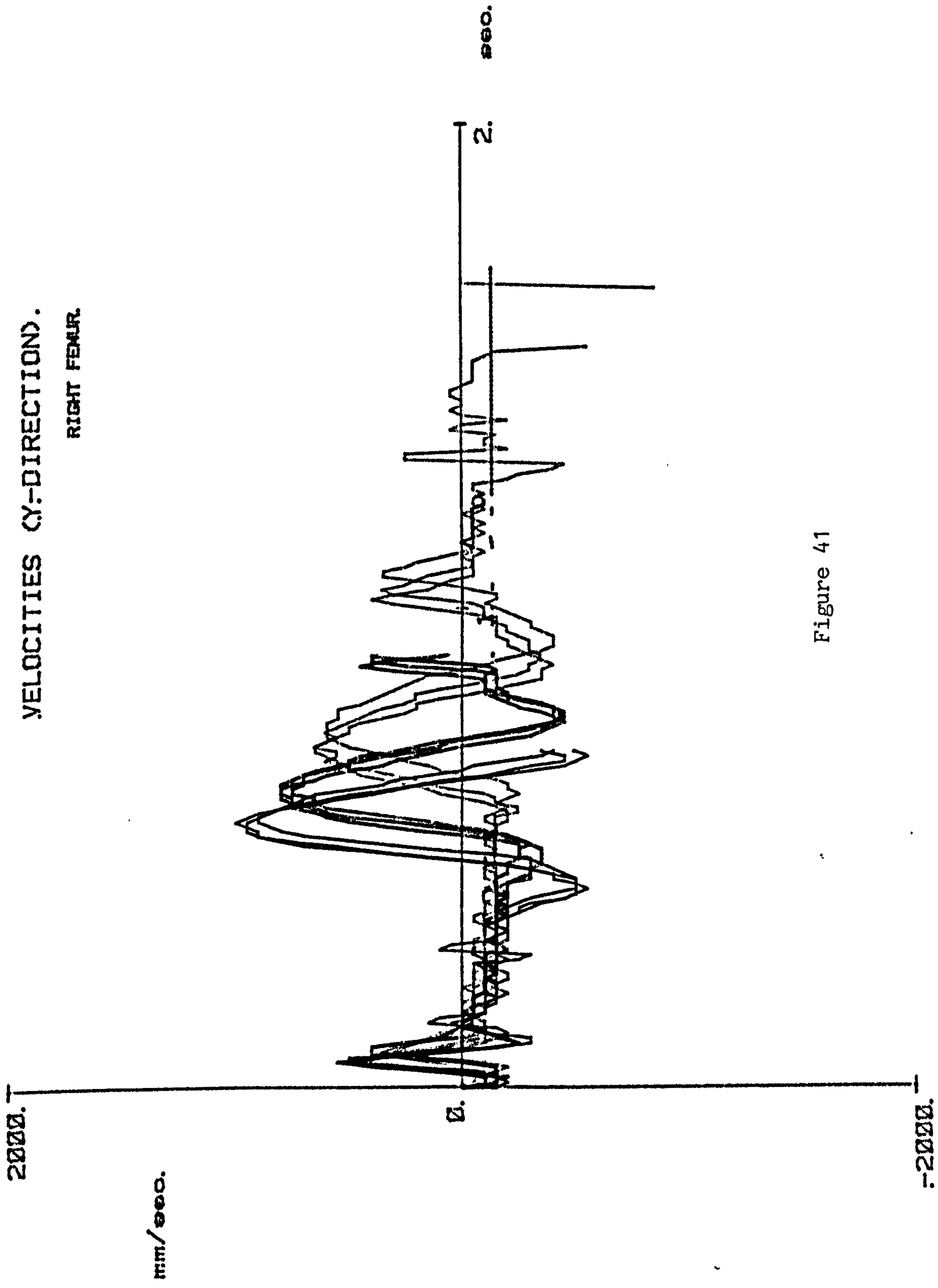

Figure 41

3500.

VELOCITIES (Z-DIRECTION).

RIGHT FEMUR.

150005. J  
150005. J  
150005. J

mm/sec.

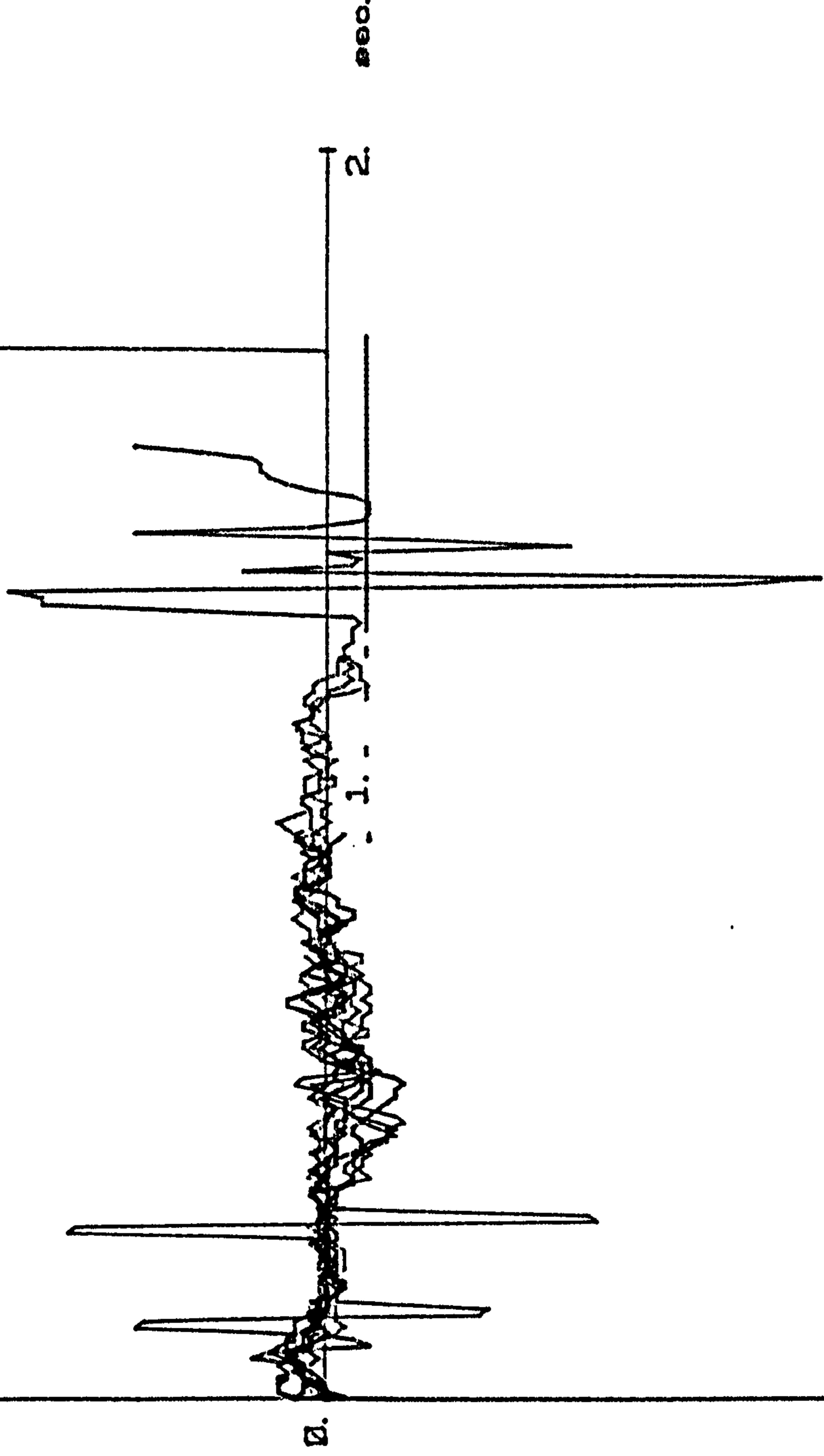

Figure 42

-3500.

STANCE AND SWING PHASE DURATIONS  
WITH INCREASE IN CADENCE.

Speed	Stance Time (secs)	Swing Time (secs)
Slow	0.56	0.46
Medium	0.50	0.41
Fast	0.44	0.36

Table 21

In the  $y$ -direction the magnitude of the maximum velocity during early swing increases with increasing speed of locomotion. This increase is more marked for the femur than for the fibula. Likewise the positive  $y$ -direction velocity in early stance increases with increasing speed of locomotion, the femur exhibiting slightly higher velocities than the fibula. The fibula also produces a negatively directed  $y$  velocity at heel strike before the positively directed velocity described above.

One general point to note is the absence of overlap in the traces for the femur as compared with fibula which in both the  $x$  and  $y$  directions, are less discrete groups for each speed.

The  $z$ -direction velocities are very difficult to interpret, but all seem to follow the same general path. One exception to this is in the femur where for the highest speed there are two large 'ectopics' in the trace. As these data was collected from an apparently healthy subject it must be assumed that the CODA system could not handle the quickly changing data from the landmarks and output rubbish data which was exaggerated when the first derivative was taken.

### 5.3 Inferences

Increased speed of locomotion is brought about by a decrease in stance phase time and a reduced period of double support time. This reduction in double support reaches its limits in running where there is no double support. In order to reduce the support phase time the body must be brought more quickly over the supporting leg, i.e. the calf which is stabilised at its distal end by the foot. This results in the landmark on the head of the fibula, not only travelling through a smaller arc than a landmark on the femoral epicondyle but doing this more slowly, as the femur 'carries' the rest of the body over the supporting leg.

As the velocity of locomotion is increased the shock absorptive mechanisms of the knee become of greater importance in order to reduce the mechanical stresses on the joint. To reduce the impact load as a result of increased momentum, the knee 'gives' at heel strike to absorb energy. This 'giving' by the knee joint results in a transient forward directed movement of the femur as the knee flexes under body weight. As speed of locomotion increases this forward directed movement increases resulting in an increase in the velocity of the landmark on the femur in the x-direction.

The negative y-direction velocity of the fibula seen at heel strike coincides with the shock absorptive

action of the knee mentioned above. The femur seems not to show this even at the higher speeds so it is assumed that the compensatory shock absorbtive action takes place in the x-direction for the femur at heel strike.

In early stance however the femur and fibula produce a positive y-direction velocity which would coincide with recovery after shock absorption, to bring about a straight leg over which the body is translated.

In the early swing phase the femur must travel upwards to allow for ground clearance, the push-off at higher speeds resulting in a higher y-direction velocity. The fibula surprisinally does not attain such high y-direction velocities so it must be assumed that this is a result of the orientation of the calf in relation to the thigh, and the pendulum type pattern the calf traces below the thigh.

In the stance phase the calf is restrained by it's contact with the floor through the foot. Any change in position of the lower limb to propel the body forward will hence be effected through the more proximal portion of the lower limb ie the thigh. This will result in a larger spread of velocities of landmarks mounted on the femur and allow for more discrete groupings of velocity profiles at the different speeds.



The existence of an inter-subject variability has become apparent from this study, but at the same time the high level of reproducibility has been highlighted.

Explanations for the characteristic velocity profiles have been offered and pave the way for an explanation of the patterns produced from abnormal gait.

## 6.0 Abnormal Gait Patterns

The author was allowed access to a number of patients both osteo and rheumatoid arthritic, who could be approached to ask for their cooperation in her gait analysis tests. One patient, (MN) proved to be very helpful and despite his disability offered to visit the laboratory as and when necessary. He was a slightly 70 year old rheumatoid arthritic patient, with two total knee joint replacements, the left a Sheehan and the right a Kinematic. His right knee replacement was a success, but his left showed medio-lateral instability on clinical examination. He experienced pain in the left knee and was judged by the Orthopaedic Surgeon to be a candidate for a revision operation.

### 6.1 Method

MN was put through the protocol described earlier and recordings of his gait with landmarks on the head of the fibula and lateral femoral epicondyle for both legs were made. Velocity profiles for these landmarks were drawn up, and from the tracings the value of the parameter at a number of turning points was measured off. These parameters for the left and right legs were compared using a t-test (see Appendix D), and areas of significant difference were highlighted as shown in Table 22 (probability level  $p=0.01$ ). The raw data used

can be found in Appendix D.

These same parameters (ie maximum values) were also obtained from a normal (N) subject and compared with those of MN. These results can also be found in Table 22.

## 6.2 Results

Looking first at the x-direction maximum velocity, which occurs in early swing phase:-

For both MN and N there is no difference in this peak value between the left and right legs.

There is a difference in the maximum velocity attained by the tibia in early swing phase, between MN and N. This will be dependent upon the speed of locomotion which for MN was slower than for N. The cycle time for MN was 1.0 sec. and for N was 0.9 sec. (And as Winter pointed out there is a nonlinear relationship between cadence and parameters of gait).

Looking at the y-direction maximum velocities:-

The maximum velocity attained by the femoral epicondyle immediately after heel strike is statistically significantly higher in N than in MN.

T-Tests.

X-direction maximum velocities

		<u>t-tests.</u>	
<u>L vs R</u>	·MN	<u>MN vs N</u>	
	NORMAL		
Tibia	t= -2.77    sig. dif. x		TIBIA
FC	t= 0.24    x	FC	sig. dif.
Combined	t= -1.66    x	t= 0.77    x	t=
		sig. dif.	sig. dif.
		AHS	t=
		t= 2.92    ✓	sig. dif.
		TC	t=
		t= -3.34    ✓	t= -1.37    x

MN vs N

Tibia	t= -3.0    ✓	sig. dif.
FC	t= -1.37    x	
Combined	t= -3.12    ✓	

Y-direction maximum velocities

TABLE 22

		<u>t-tests.</u>	
<u>L vs R</u>	·MN	<u>MN vs N</u>	
	NORMAL		
BHS:	t= -1.21    x		
AHS:	t= 0.19    x		
TO:	t= -0.22    x		
		sig. dif.	
		TIBIA	
		t= -0.88    x	sig. dif.

Likewise the maximum velocity at toe off is significantly higher in N than MN. Again some of the variance in these two parameters is likely to be due to the speed of locomotion but the rest will be due to the difference in mechanics of the knees of the two subjects.

Qualitatively the gait of MN was executed less efficiently than that of N, MN having a more laboured gait with less joint mobility, particularly on the side with the lax knee. (Recall however that there was no significant difference between the two sides.)

### 6.3 Inferences

For this to have been a comprehensive study of the differences in gait patterns between 'normal and abnormal', a larger number of normal subjects would have to have been used from which to compile a normal data base for comparative purposes. The test did however prove useful for the comparison of left and right sides, which were shown not to be significantly different from one another, for both subjects. The two areas of difference in the  $y$ -direction are those points in the gait cycle where the shock absorptive mechanism of the knee is coming into play.

The velocity after heel strike can be thought of

as a measure of the recovery of the knee after the shock it undergoes when the foot impacts the ground. It is hypothesised that a sound knee will show an element of spring immediately after heel strike to bring the body up and over the supporting leg. This will be seen as a peak in the velocity curve after heel strike for a landmark mounted on the femur.

Likewise the velocity at toe off will be proportional to the push-off force exerted by the leg as it propels the leg into swing phase. As with the velocity after heel strike, it will be indicative of soundness of the knee joint and will also be related to the speed of locomotion.

It was noted that in the x-direction on the tibial trace for MN's left side, unlike with N there was no peak in the trace at heel strike. This peak in x velocities had been taken to be part of the shock absorption activity, alongside the peak in the y-direction, both of which are seen in Winter's work using the cinematographic technique. MN had instability in his left knee and antalgic gait as a result of pain in this joint. It would seem that, this was then a manifestation of impaired function at this joint. A possible extension of this is considered in the discussion chapter which details areas for further study, including that of patterns of shock loading with

changes in knee condition.

The question then arose would this deviation from the normal show up as a difference in the behaviour between components of the joint above and below it. A more sensitive parameter, acceleration was chosen and the profiles produced from landmarks sited above and below the joint were investigated.

Once again the big problem of cross-point conflict arose resulting in areas of the velocity profiles being useless for analysis purposes. There seemed a strong justification for data collection using one landmark at a time. This would obviously necessitate more runs being carried out, and be out of the question if we were wanting to look at above/below knee movements at the same time. It is obviously not the ideal situation but because of the limitations of the CODA-3 hardware is the only way of acquiring clean data.

## 7.0 Acceleration Profiles

### 7.1 Simulation of Joint Laxity

As a preliminary to an investigation into acceleration of landmarks placed around the knee joint a test rig was devised to simulate the movements of a lax knee i.e. small antero-posterior or medio-lateral

displacements. The sensitivity of the CODA system to such small rapid oscillations was tested by noting the displacements in the x, y, and z directions of the landmark on a test rig, when part of the rig was manually displaced from its resting position. The scale attached to the rig allowed for a rough assessment of the amount of movement brought about by application of the manual force. The landmark displacements themselves were taken from the Signet VDU. The rig is described below, and the method used to assess the noise on the acceleration data, which would be the limiting factor is described.

#### 7.1.1 Method

The rig consisted of two plates made of cast iron, one centimetre thick, measuring 10x15 cm with a separation of 4 1/2 cm. The separation was brought about by eight springs, four sited at the four corners of the two plates, and a second set sited just inside these (see Fig.43). Removal of one set of springs resulted in an increased range of motion of the top plate relative to the bottom, hence modelling the increased laxity of the ligament or meniscal damaged knee. The lower plate had an extension onto which a CODA landmark could be placed. A second landmark on the top plate yielded data about the movement of the top plate when motion was brought about by a manual



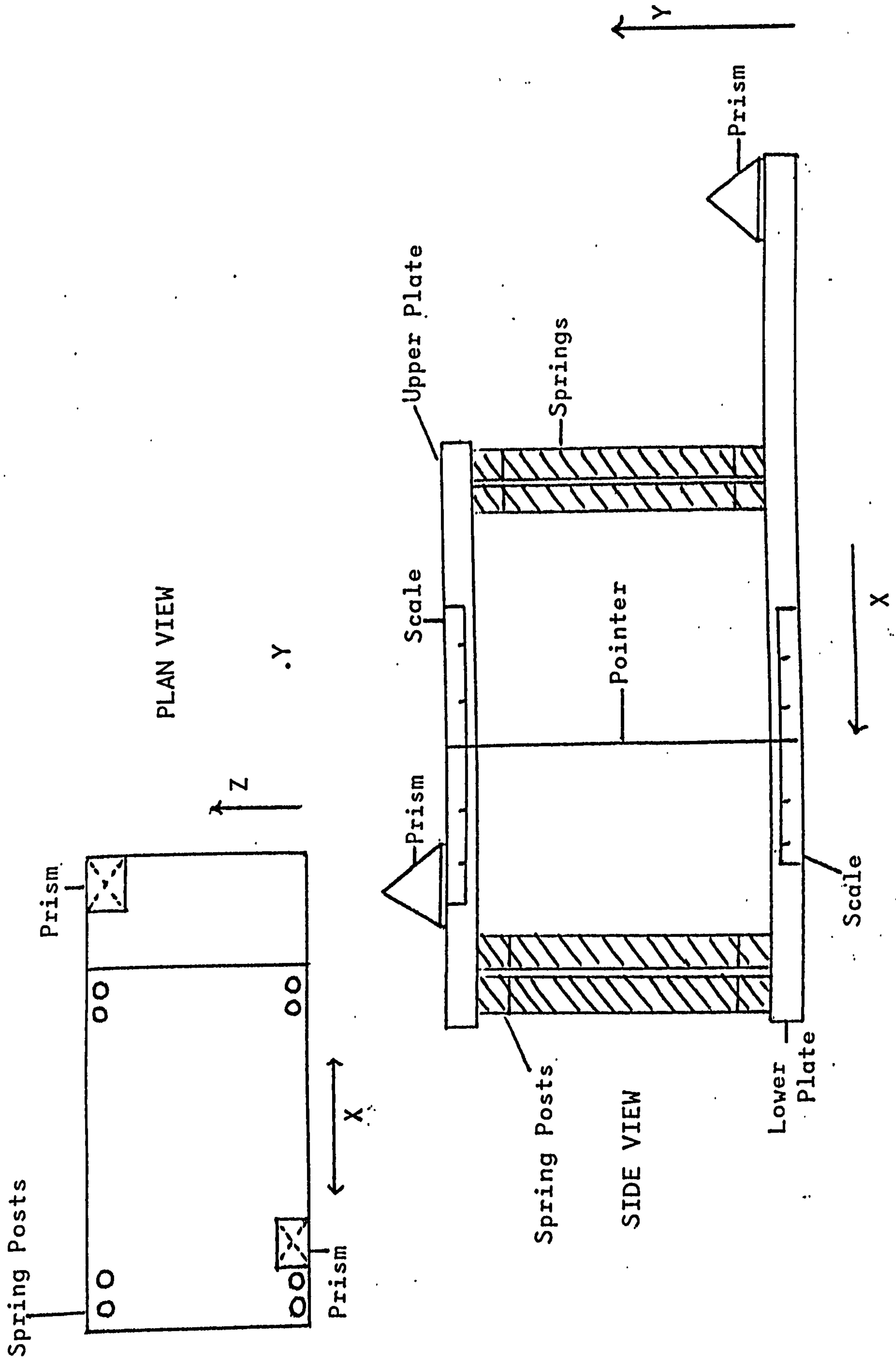

Figure 43 . . . Test Rig for Simulation of Joint Laxity.

force applied to it. By choosing different combinations of springs more or less movement of the top plate could be produced.

A measure of the noise inherent in the CODA system can be found by looking at the output from the stationary landmark on the bottom plate. Double differentiation will yield the noise on the acceleration data for a stationary landmark and can be borne in mind when dealing with other acceleration data.

Secondly at a later date after development of the appropriate software, the difference in acceleration of two stationary CODA landmarks, sited on a bench in the field of view of CODA, was calculated for the 2 second data collection period. This was repeated three times and the separate x, y and z direction accelerations were plotted out using the Hewlett Packard plotter driven by laboratory software.

### 7.1.2 Results

Table 23 shows the displacements of the landmark sited on the top plate when the motion induced in the plate is altered by changing the combinations of springs separating them. As would be expected maximum induced excursions produced the widest range of

# DISPLACEMENTS OF LANDMARKS IN KNEE LAXITY

## SIMULATION EXPERIMENT.

Springs	Induced Motion cm. (From scale)	Coordinate Value Range		
		X	Y	Z
x2 (s)	-	157	58	94-97
x2 (em)	0.6	149-156	57-58	90-98
x1 (so)	-	155-156	57	93-101
x1 (oem)	1.1	145-157	54-56	85-104
x1 (si)	-	157-158	55-56	90-101
x1 (iem)	0.7	148-156	54-55	83-103

### Key

- 1,2 One or two springs
- s Stationary plates
- em Maximal Excursion of top plate
- o Outer set of springs only
- i Inner set of springs only

Table 23

coordinate values. Although the motion was induced in one direction only the movement of the plates was not restricted to this plane alone. Removal of the inside set of springs resulted in greater excursions of the plates than removal of the outside set, as was predicted. With no induced motion, the plates, separated by the outside springs only, underwent greater ranges of motion than when separated by the inside springs only. Even when supposedly stationary the landmark values drifted, to a greater extent in the z direction than in either of the others.

Table 24 likewise shows the displacements of the stationary landmark on the lower plate, for a number of trials. Once again the z direction proved to be the most sensitive one, with displacements in increments of 1mm up to 3mm from the starting value. (When looking at the CODA data the LSI-11 uses data to the nearest millimeter, however when taking values from the VDU we chose a highest accuracy of 0.5mm—to allow for greater accuracy in our calculation of acceleration noise.)

The noise inherent in the CODA system was calculated to be between 5 m/s/s and 10 m/s/s.

Plots 44, 45 and 46 show the difference in acceleration between two stationary landmarks. For all three directions there appears to be very little

STATIONARY LANDMARK DATA

(Increments of 1mm in all directions)

Landmark Number	Spread of data. (mm).		
	X	Y	Z
4	-1	0-1	1-3
4	-1	0-1	1-3
4	-2--3	2	0-3
4	0	0	-1--2
4	0	0	0-2
4	1-0	0	-1--3

Table 24

ACCELERATS (X-DIRECTION).

STAT .

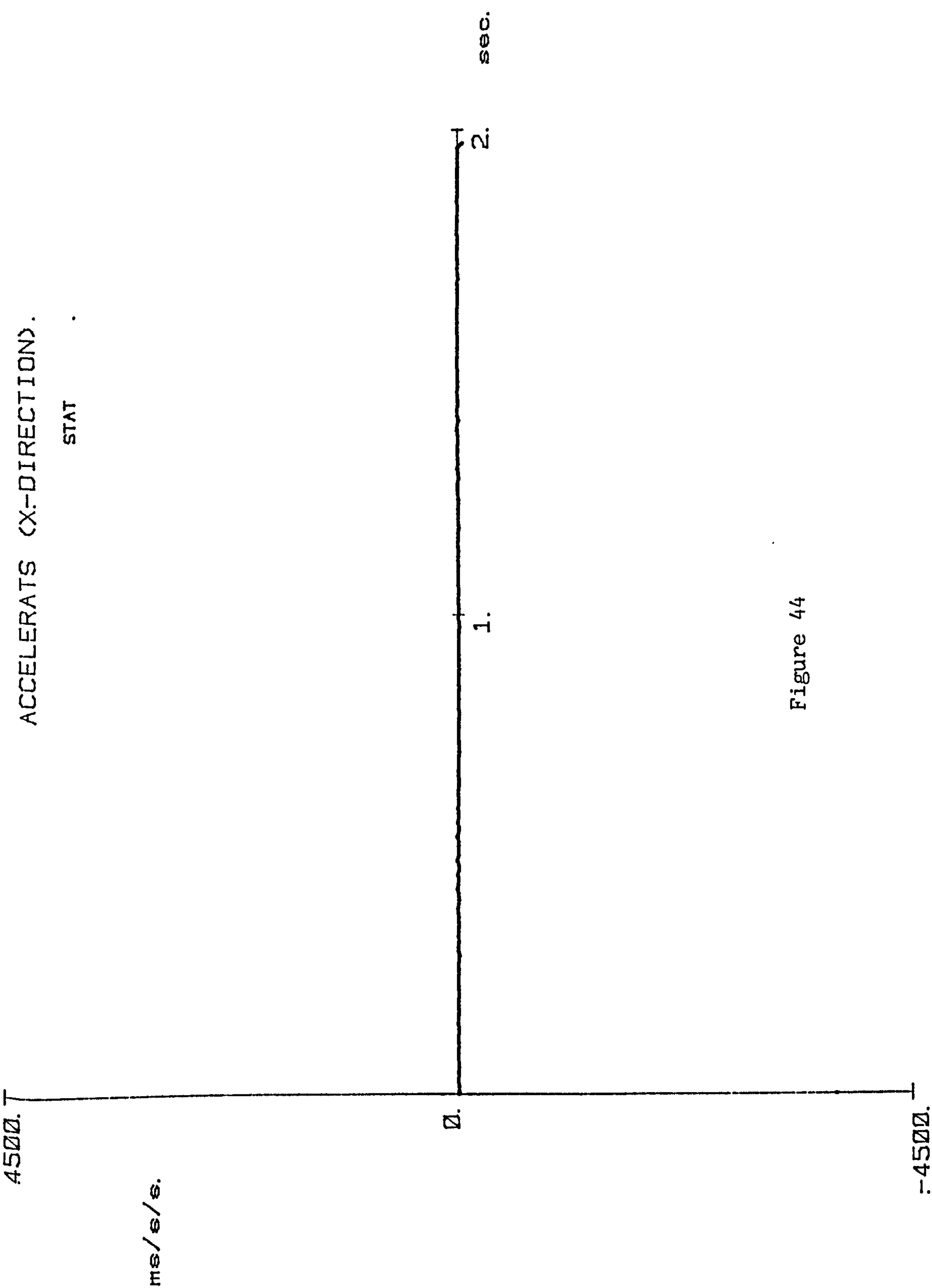

081285.  
081285  
081285

Figure 44

-4500.

ACCELERATS (Y-DIRECTION).

STAT .

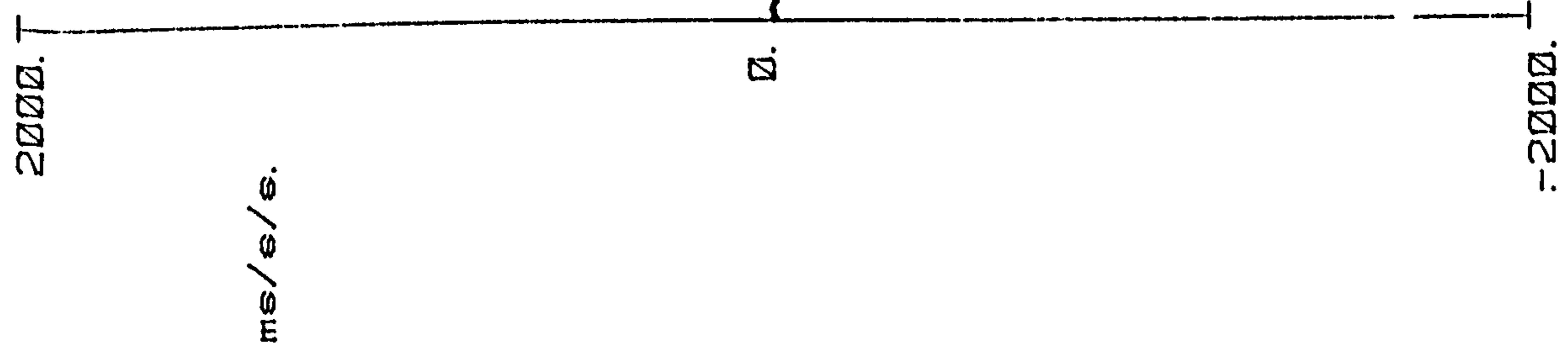

08128  
08128  
08128

Figure 45

ACCELERATS (Z-DIRECTION).

STAT .

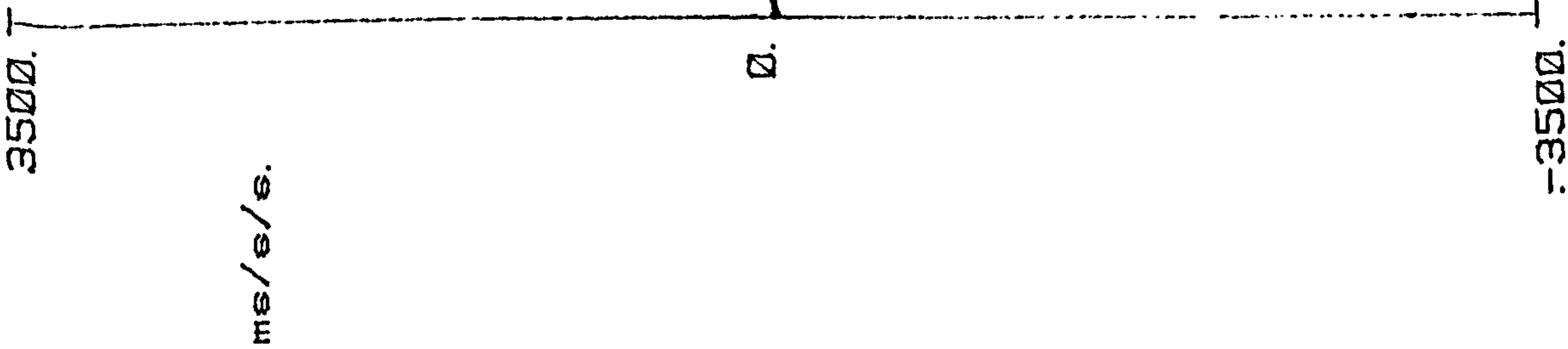

08128  
08128  
08128

Figure 46

-3500.



acceleration and hence displacement (drift) of the two landmarks relative to one another. This analysis which allows us to look at the difference in acceleration between the landmarks, was chosen as being particularly sensitive to alterations in position of the landmarks relative to one another. We are only interested in these changes in position of the landmarks relative to one another for the moment and are hence not concerned that this analysis isn't going to highlight a mass drift of data.

### 7.1.3 Inferences

The CODA system has been shown to be capable of picking up the rapid oscillations produced by our test rig, which was built to model joint laxity of differing degrees. The acceleration noise was calculated as around 5-10m/s/s. Modifications were made to existing software to allow for calculation of landmark accelerations and the difference in acceleration between any two landmarks. As with the velocity calculation, averaging over a number of data values(x4) was used as well as low pass filtering.

The results obtained from the two stationary landmarks would suggest that whilst looking at the difference in acceleration between the two we can be sure that there is little noise in the acceleration

data.

This leads on to the next set of experiments which were devised to look at the difference in accelerations of prisms located directly above and below the knee joint.

## 7.2 Knee Accelerations

This experiment was designed to test the hypothesis that in an unsound (lax—whether due to ligament, meniscal or prosthetic breakdown) knee joint, linear accelerations of landmarks mounted directly above and below the joint give an indication of the condition of the joint. We would expect the smooth waveforms of biomechanically sound knees to break down when the slip /jerk movements of a lax knee take place. If this is not the case then either of two conclusions can be drawn:-

1. That even though unsound, the condition of a joint is not expressed in the linear acceleration of the segments surrounding the joint.

2. Although a joint may be lax when examined clinically, when used for everyday activities such as walking (ie. dynamic events) this laxity is

controlled. The musculature, soft tissue, ligaments and congruity of the joint itself are the prime candidates for this control.

Once again the author encountered the problem of cross point conflict. To look at the kinematics of the two components of the knee joint, ie. the femoral condyles and the calf (head of fibula), data had to be collected from the two at the same time to ensure that the data points from which we were to calculate the accelerations were perfectly synchronised. The landmarks inevitably came into horizontal or vertical alignment at several points in the gait cycle, as before this information had to be ignored. We are hence limited in our ability to analyse the events of the whole gait cycle.

#### 7.2.1 Method

Using the usual protocol data was collected from MN the volunteer knee replacement patient. Landmarks were located on the lateral femoral epicondyle and the head of the fibula. Data collection and storage allowed for the plotting of the difference in acceleration of the two landmarks in the x, y and z directions. This same information had been collected from a normal volunteer to ascertain the smooth waveforms expected, and to highlight the points in the

sait cycle where cross point conflict (cpc) was likely to occur.

### 7.2.2 Results

Plots 47,48 and 49 are those for the normal volunteer and those labelled 50 to 55 are from MN. There are several areas on the plots where there is an obvious difference between the two. These occur for MN's left knee in the z and y-directions at heel strike. For his right they occur at midstance in the z and x-directions (see arrows). We had hypothesised that points in the sait cycle of maximum joint loading might well be the time when the joint exhibits slip/jerk movements indicative of a functional joint laxity.

Comparing the occurrence of cpc between MN and the normal volunteer it is apparent that the pattern of interference between landmarks is different for both. The duration of cpc at and before heel strike is longer for MN than for the normal. In MN cpc also occurs at toe off whereas it does not in the normal. There are two possible explanations for this difference:-

1. Different siting of the landmarks for each - this is very doubtful as care was taken to replicate the mounting sites.

1412E  
1412E  
1412E

ACCELERATS (X:-DIRECTION).

FC/FB

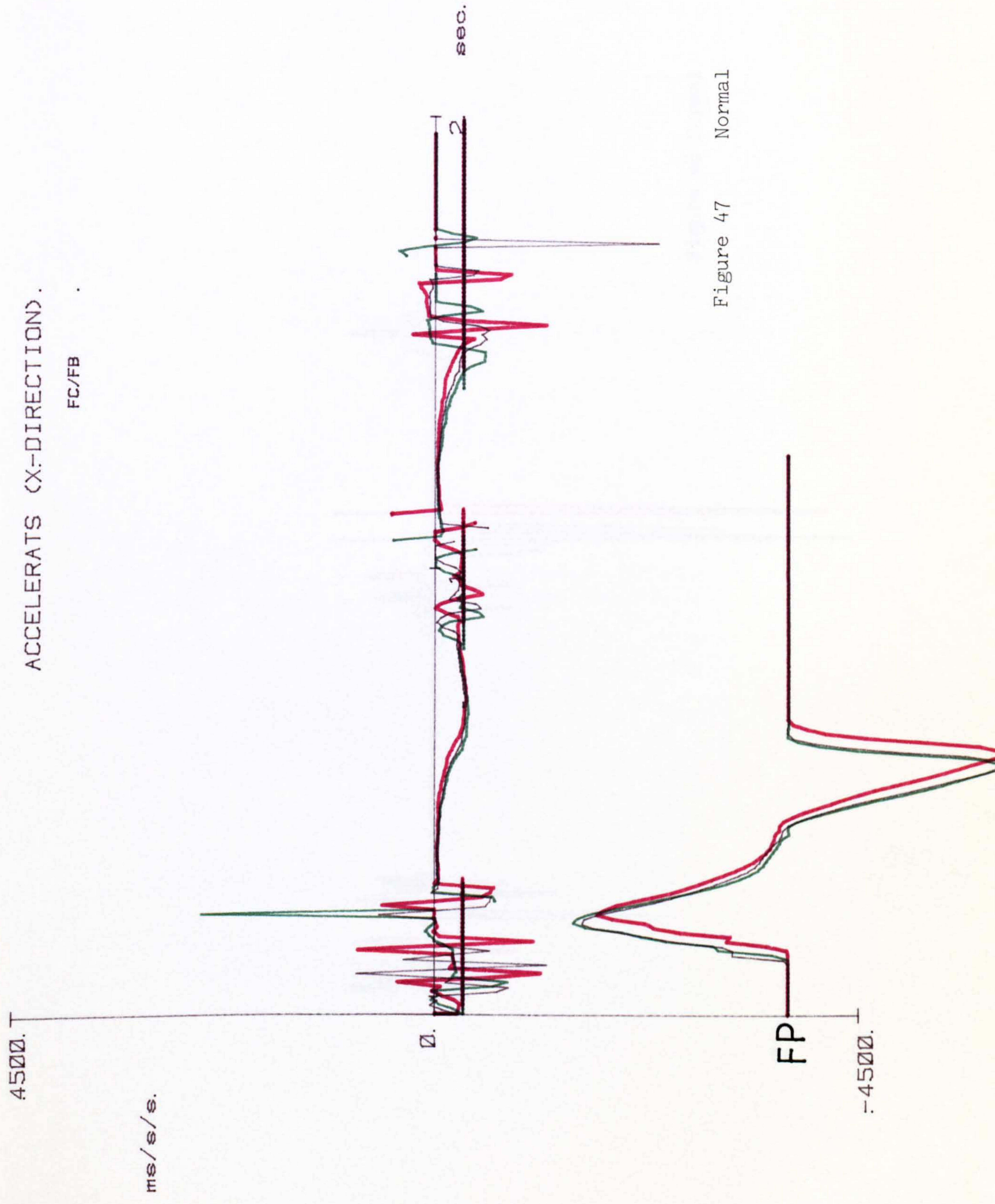

Figure 47 Normal

ACCELERATS (Y-DIRECTION).

FC/FB

2000.

ms/s/s.

0.

FP

-2000.

141285. JT  
~~141285. JT~~  
141285. JT

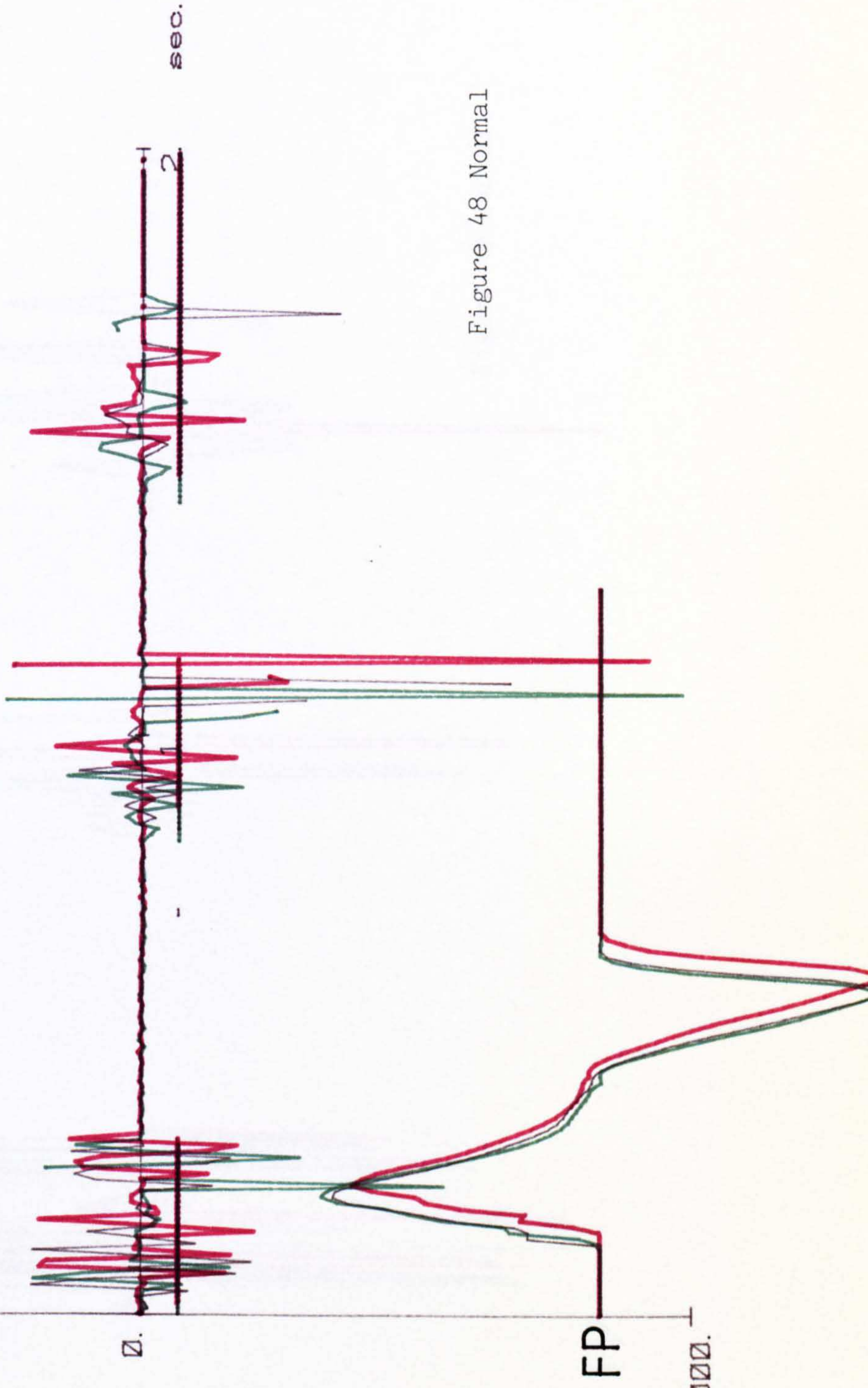

Figure 48 Normal

141285. J  
~~141285. J~~  
141285. J

ACCELERATS (Z-DIRECTION).

FB/FC

3500.

ms/s/s.

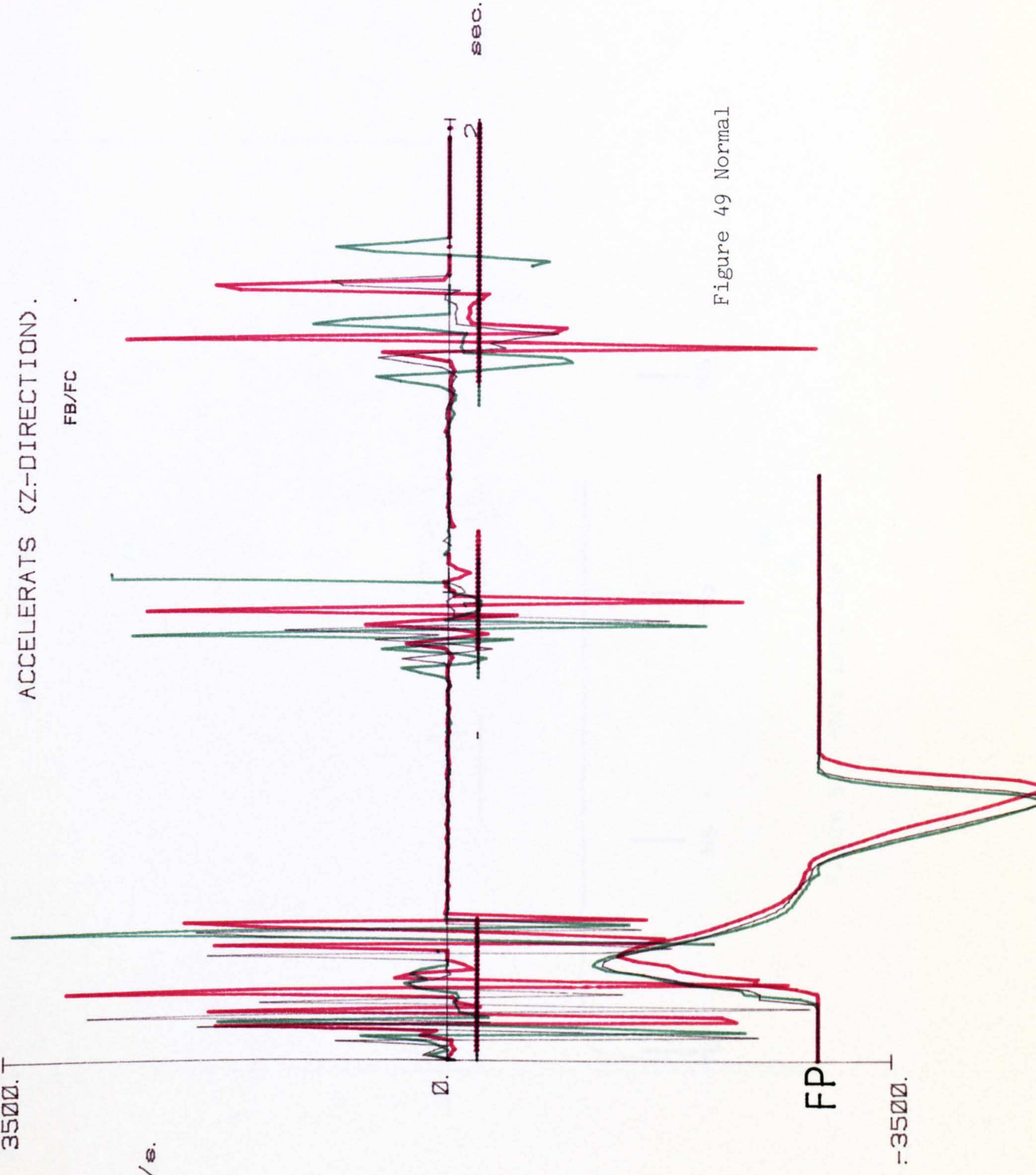
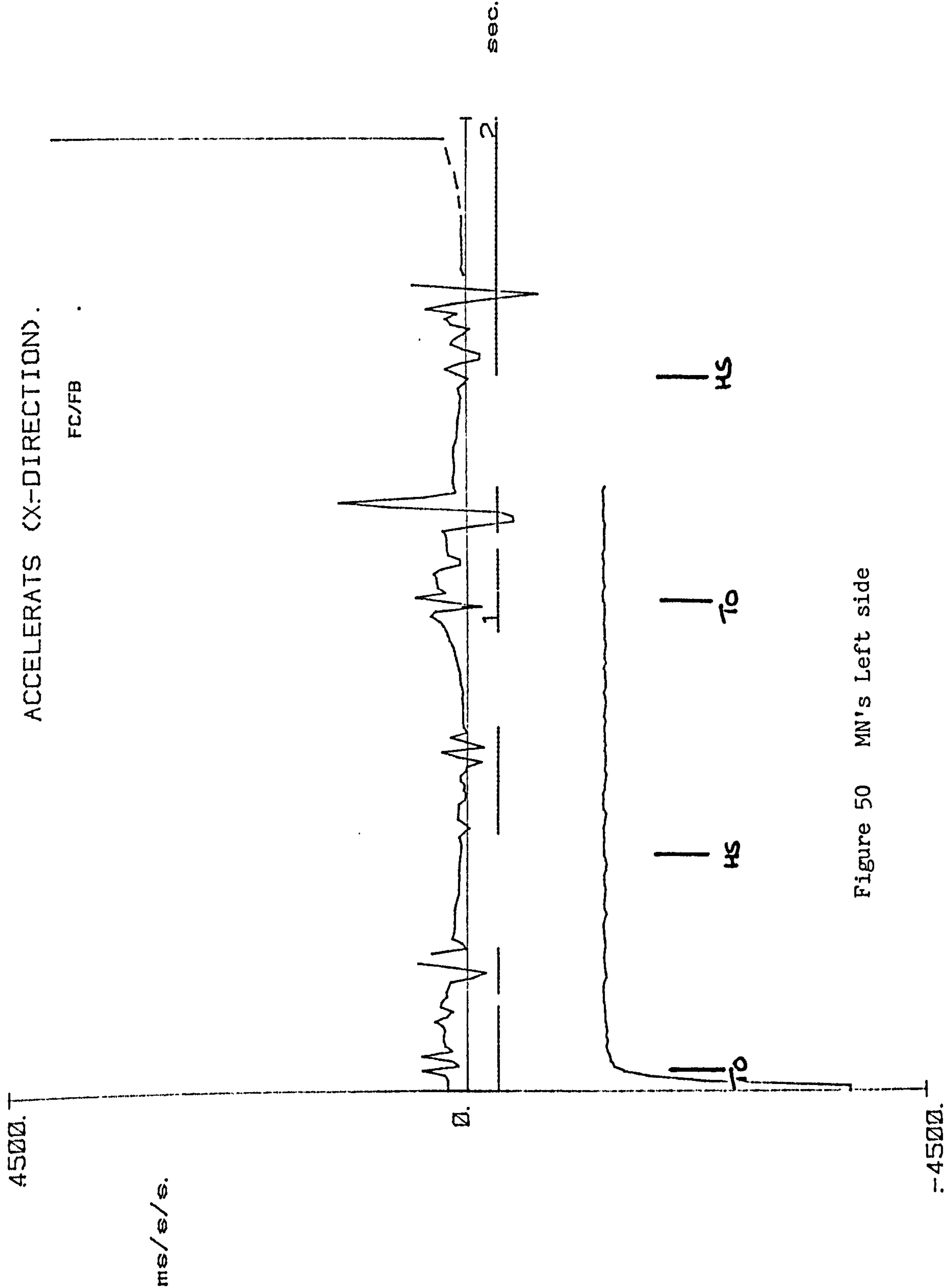

Figure 49 Normal

FP

-3500.



170984.S1

Figure 50 MN's Left side



ACCELERATS (Y-DIRECTION).

FC/FB

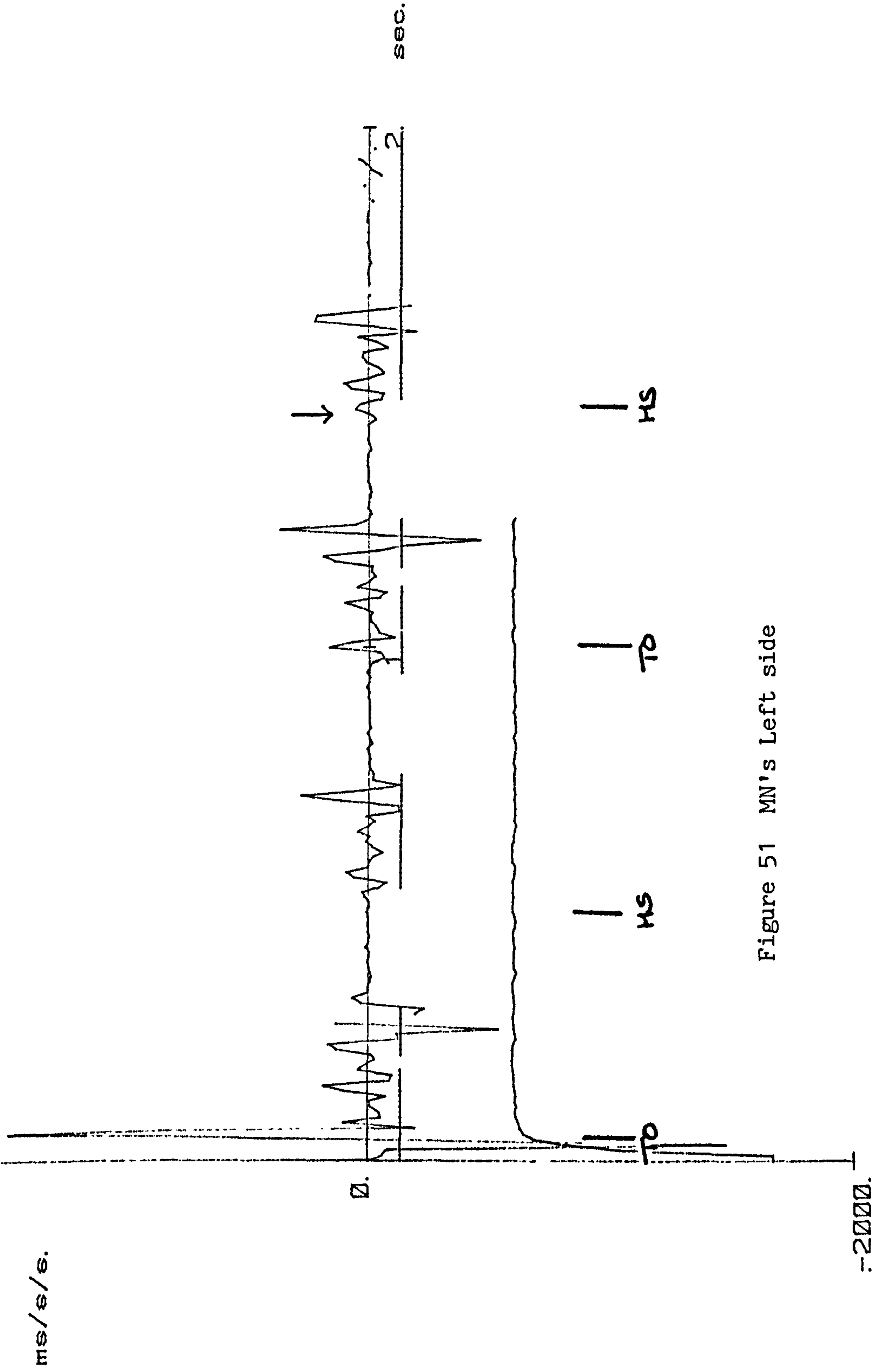

170984. S1

Figure 51 MN's Left side

-2000.

3500.

ACCELERATS (Z-DIRECTION).

FC/FB

170984. S1

ms/s/s.

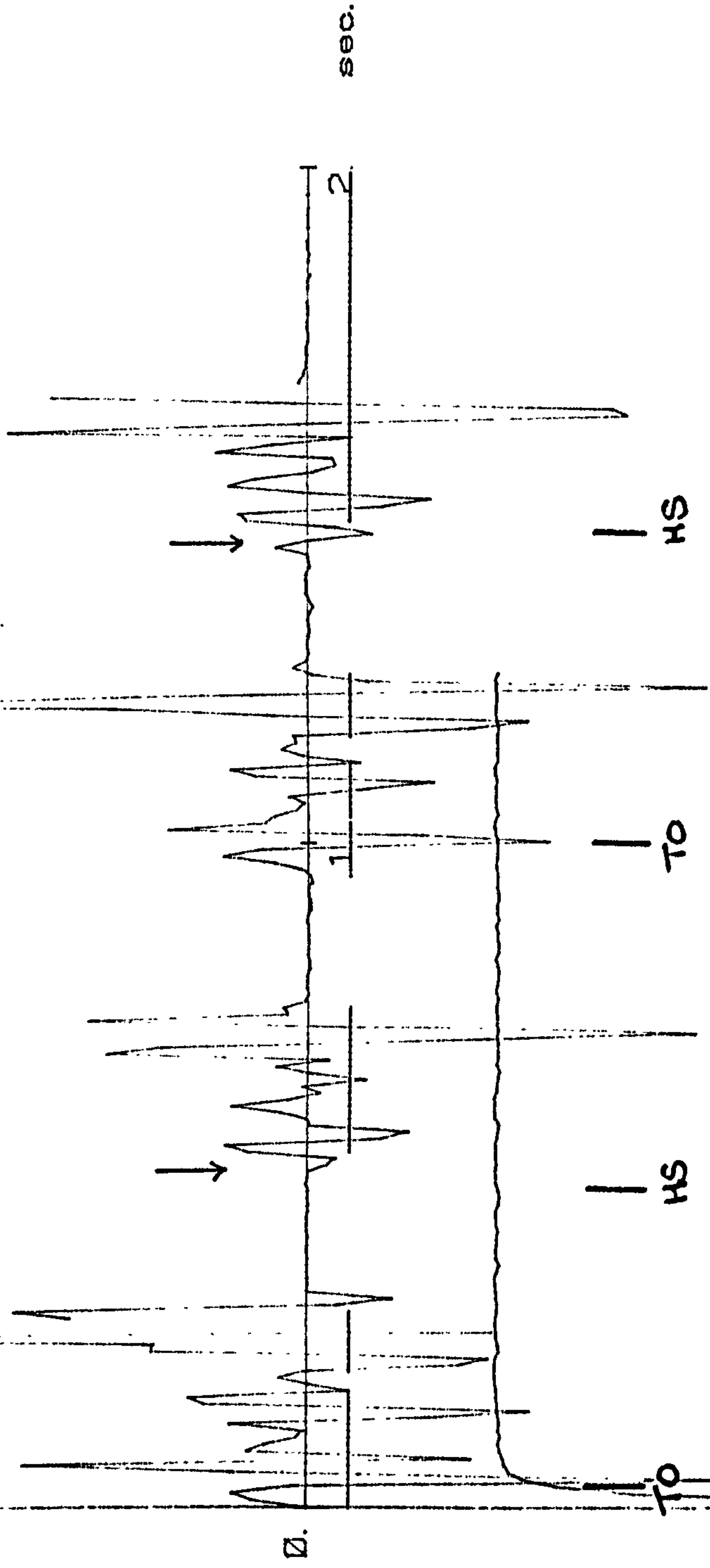

Figure 52 MN'S Left side

-3500.

ACCELERATS (X-DIRECTION).

FC/FB .

170984. S

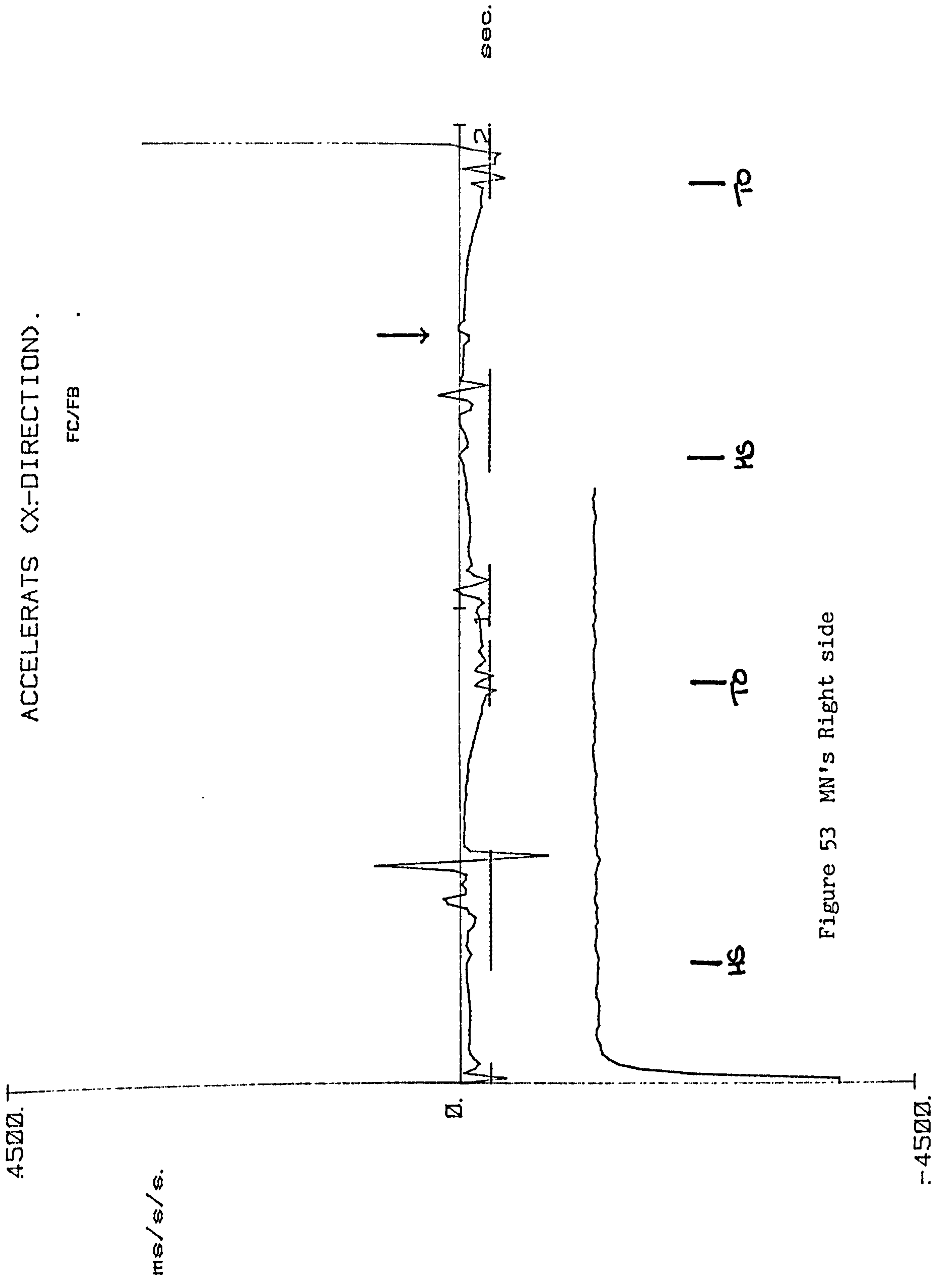

Figure 53 MN's Right side

2000. | ACCELERATS (Y-DIRECTION).

FC/FB

170984. S

ms/s/s.

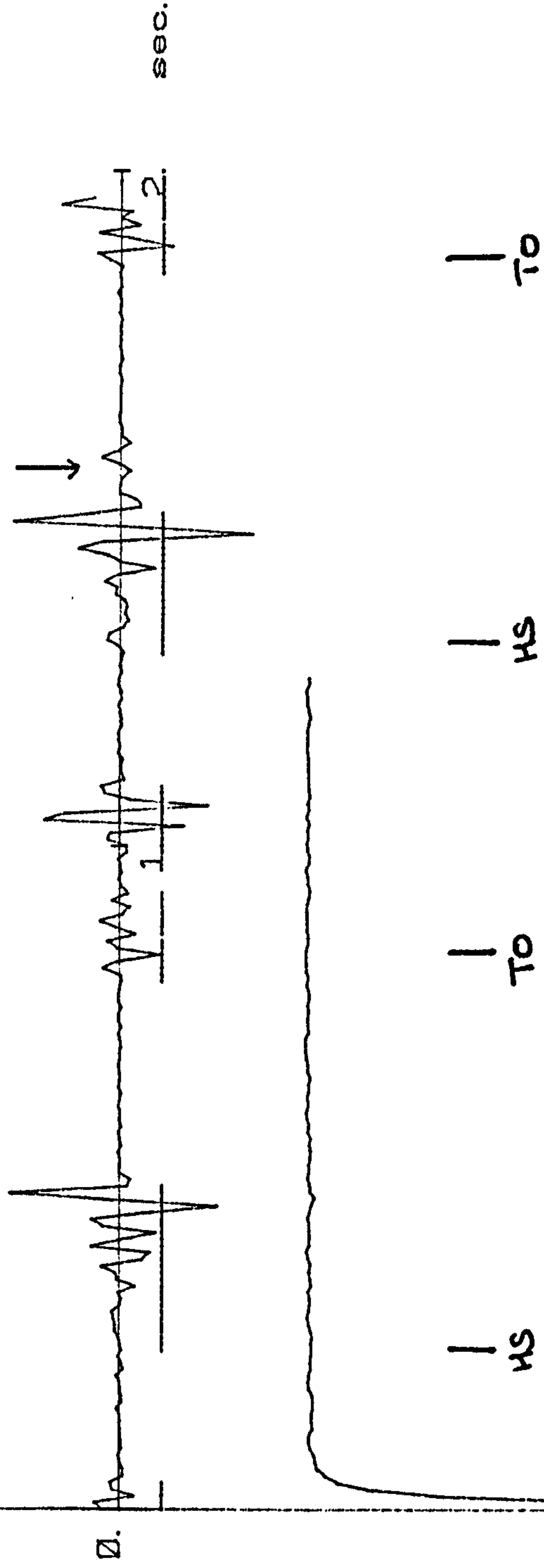
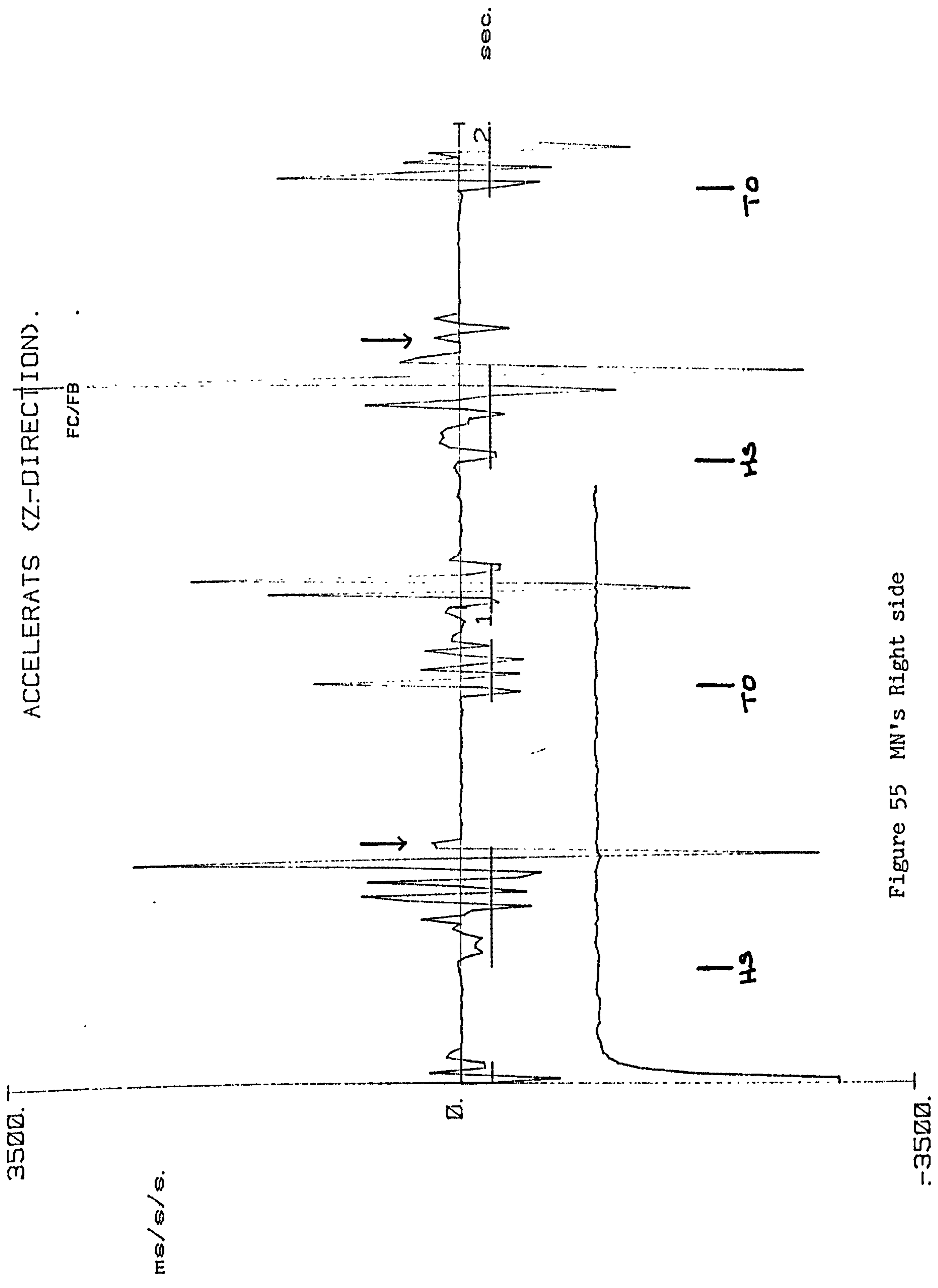

Figure 54 MN's Right side

-2000.



170984. S1

Figure 55 MN's Right side

2. The kinematics of the joint are such that cpc occurs at different stages of the cycle.

### 7.2.3 Inferences

Although not striking evidence the results described above would suggest that monitoring the linear accelerations of landmarks mounted around the knee joint give an indication of the condition of the joint, if only to reinforce the clinical judgment based on physical examination of the patient in the supine position.

The cpc limitation of the CODA-3 software may be put to advantage, by interpreting it's occurrence as indicative of the kinematic behaviour of a joint. That is if under identical conditions, landmarks sited at the same position on two individuals or on different occasions on the same individual, go out of view at different parts of the gait cycle, this could shed light on the different/changed kinematic behaviour of the joint.

The next stage in the investigation would be to look at the serial dynamic responses during gait, from the pre operative condition through to post operative recovery, (which will be in terms of years). It is suggested that any change in these parameters ie.

difference in acceleration of parts comprising a joint, would indicate a change in joint condition and hence be used as a tool in the assessment of post operative improvement/deterioration. Age changes it is suggested would be less evident in prosthetic knees compared with natural knees, the chance of any gross change in them being due to age alone is very unlikely. (NB Other than the age correlated changes due to the magnitude of cyclical loading).

### B.0 Supplementary Experiments

A set of supplementary experiments will now be described along with a description of the results which were obtained. The aim of most was to test the flexibility of CODA as a research tool.

The potential of each experiment has not been fully explored, so the reasons and details for performing each are in parts quite shallow. The experiments are the following.

Pelvic Velocities

Sagittal and coronal plane knee angles

Static knee dimensions

Pelvic Velocities

As stated earlier the displacement of the centre of gravity in normal locomotion is kept to a minimum, usually remaining within the pelvis. This in turn keeps the total energy expenditure associated with gait down to a minimum, where potential and kinetic energies are played off against one another.

The centre of gravity's displacements are restricted to this small area by a number of factors all of which contribute and bring about the movement of the body through space. The interplay of these factors is such that the centre of gravity describes a sinusoidal curve when projected onto the horizontal plane. Inman et al (1981), lists these factors as the following:-

1. Pelvic Rotation
2. Pelvic List (tilt)
3. Knee flexion instance phase  
    Reducing vertical displacement
4. Action of the foot
5. Lateral displacement of the body
6. Counterrotation of the shoulders

#### Pelvic Velocities

One of the most readily detectable factors is the



pelvic rotations, accentuated in females and where clothes allow a clearer visualisation of the underlying activity.

It was decided that as a small pilot study CODA would be used to monitor the movements of the pelvis during a gait cycle. Attachment sites for the CODA landmarks were investigated. The only readily palpable bony landmarks are the anterior iliac crests, which would allow us to monitor the movements of a point distal to the centre of gravity but which lies in close approximation to it.

The subject used for the test was a 19 year old male who had been attending an outpatients clinic after a road traffic accident. He had an anterior cruciate ligament rupture in the right knee, which resulted in it opening laterally at 20 degrees flexion in comparison with the left. However there was no instability and he could obtain full extension.

The landmarks were mounted by aid of a belt which was made to sit over the anterior iliac crests. The usual protocol was followed, with the stance phase being identified by the force plate tracings.

The raw data were further manipulated by calculating the velocities of the two mounted

VELOCITIES (X-DIRECTION).

RT ILIAC CR.

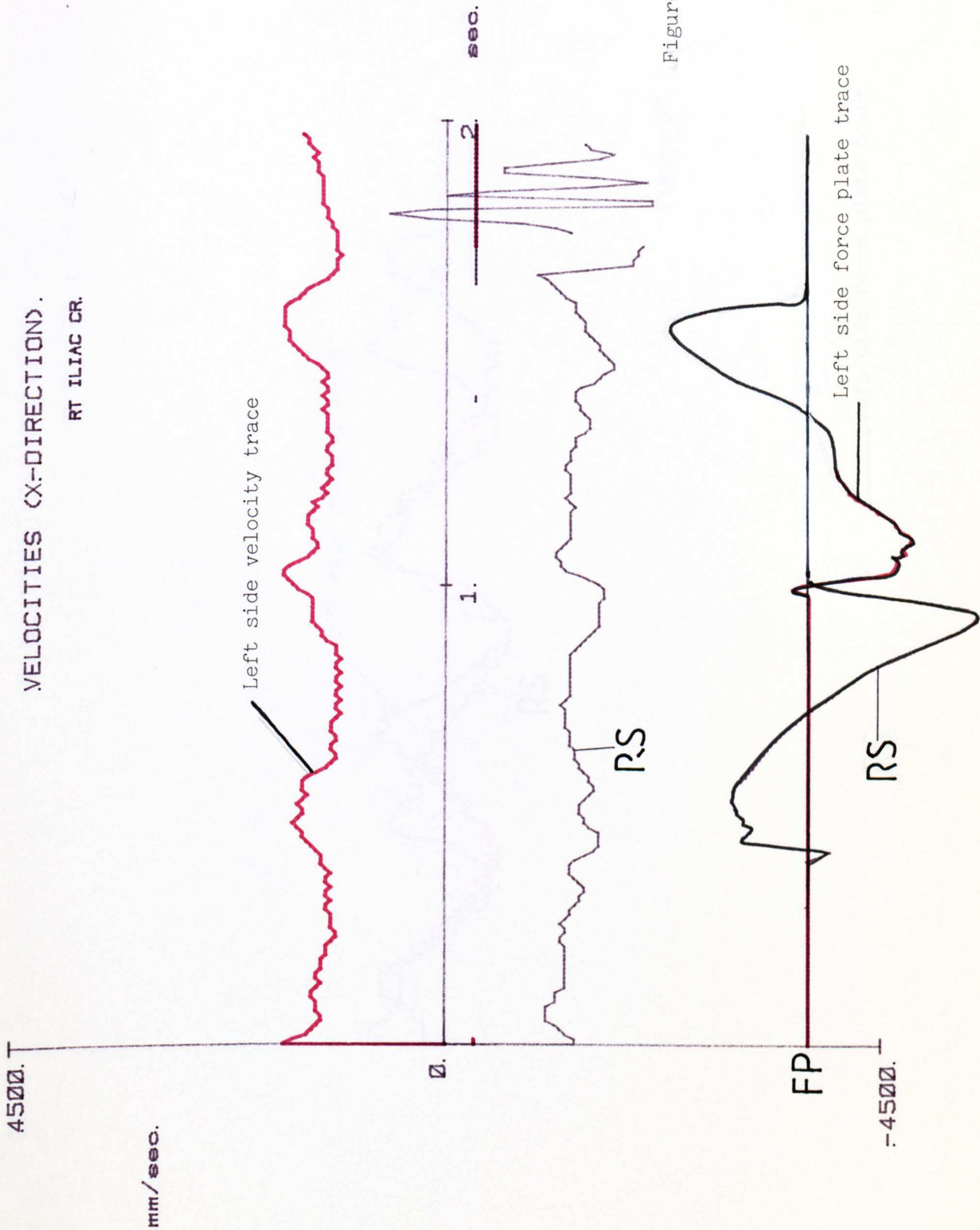

Figure 56

VELOCITIES (Y-DIRECTION).

RT ILIAC CR.

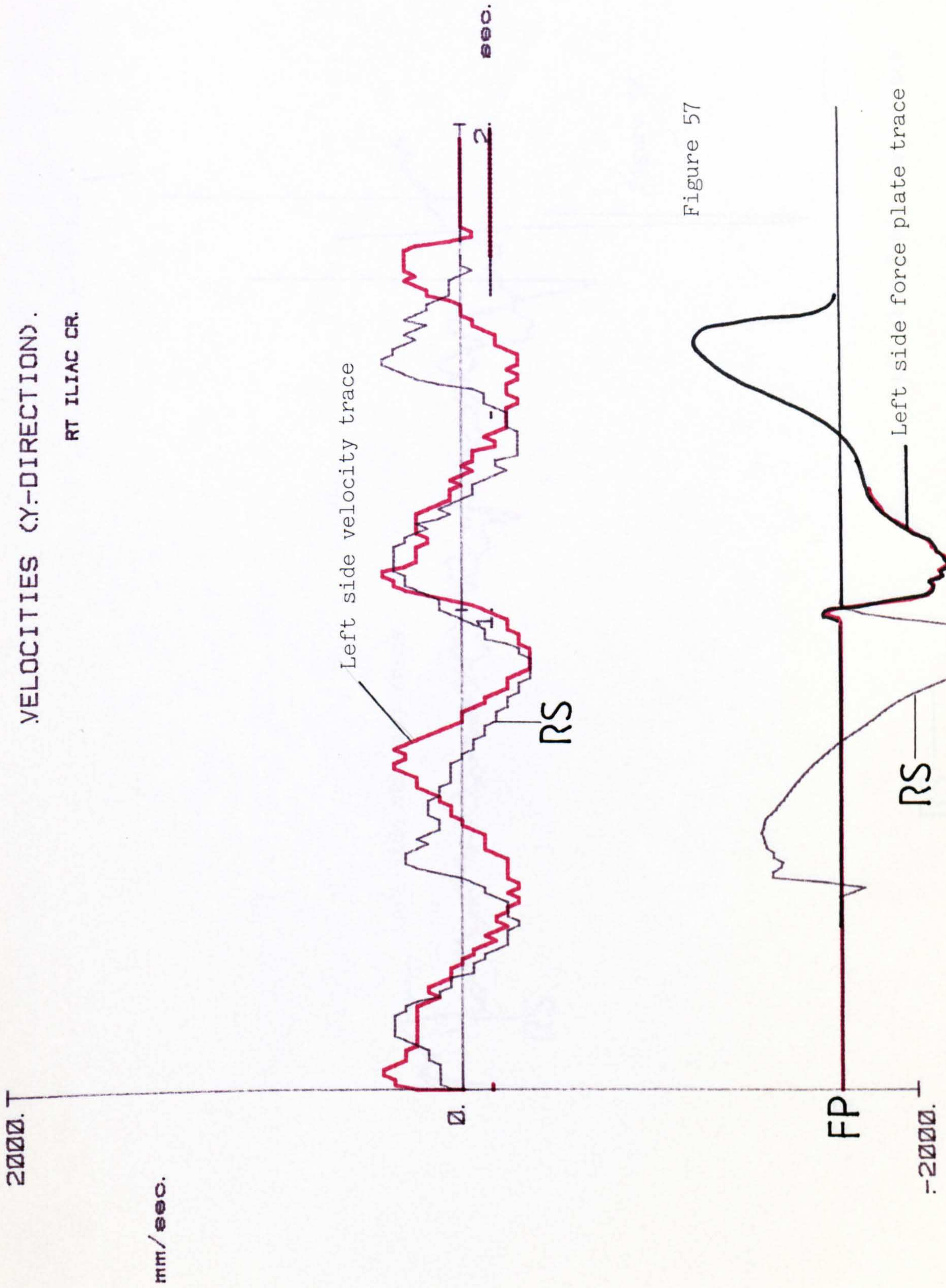

Figure 57

VELOCITIES (Z-DIRECTION).

RT ILIAC CR.

3500.

mm/sec.

Left side velocity trace

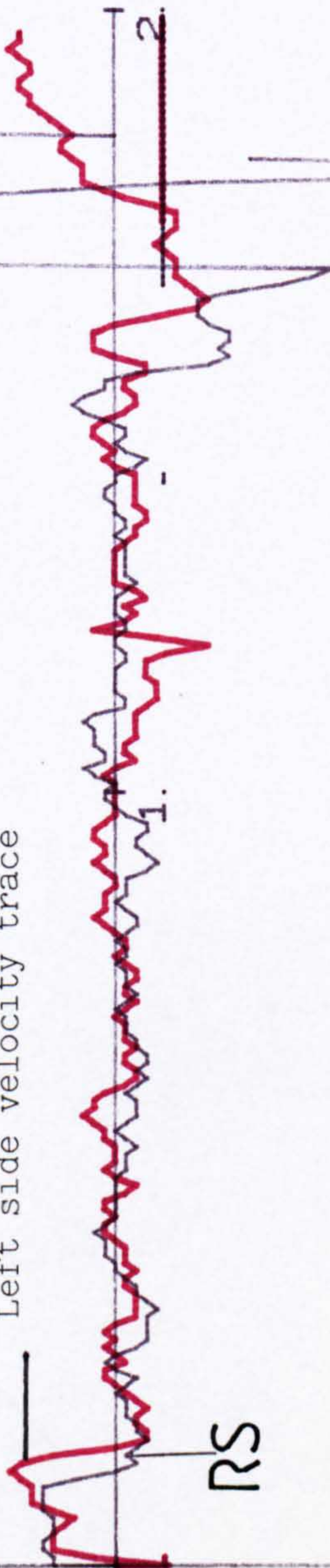

RS

sec.

Figure 58

FP

RS

Left side force plate trace

-3500.

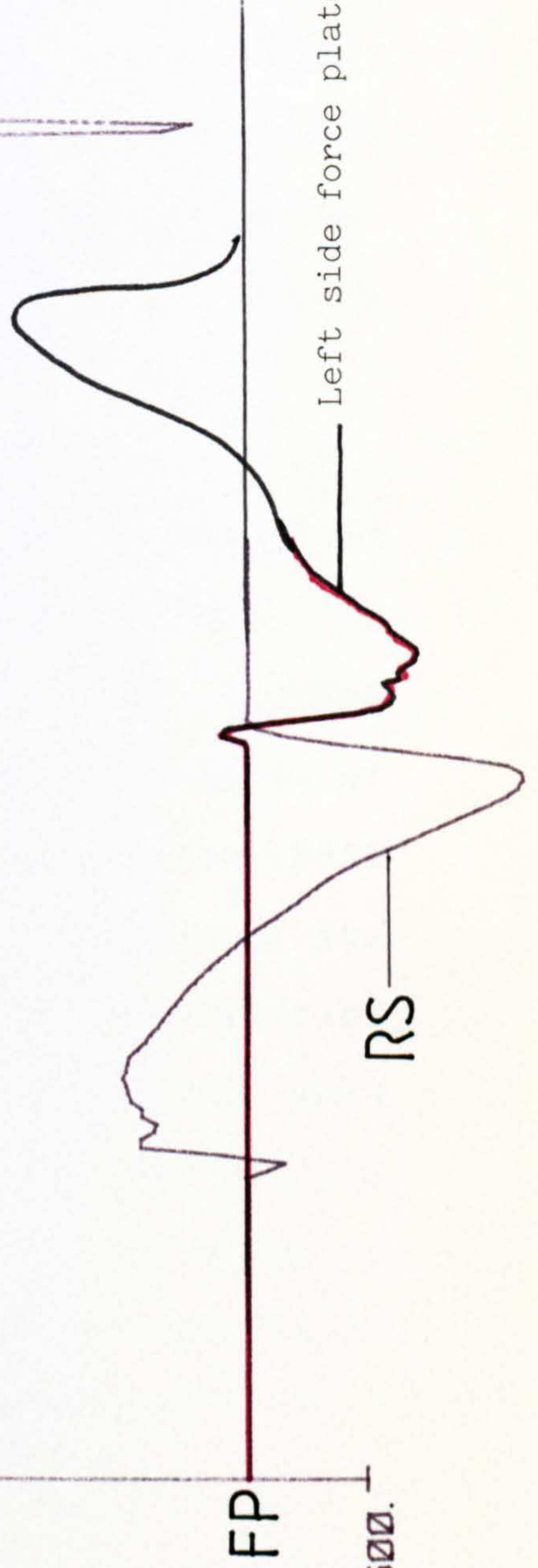

220785. K1  
220785. K1

landmarks, using the laboratory software. The results were plotted out using a Hewlett Packard plotter, as three separate plots of velocities versus time. (See figure 56 to 58). Included on each plot are the start and end points of the stance phase, identified by the extremes of the force plate information (FP) which for the right leg (RS) are inverted due to the co-ordinate system.

As had been expected the x and y direction velocities have an underlying sinusoidal pattern, the y (vertical) direction more so than the x. In the x-direction the heel strike and toe off points of inflexion have the same characteristic shape for both the left and right sides. Likewise the slopes of the curves (accelerations) in the y-direction are the same shape for left and right. In the z-direction again there is a faintly discernable underlying pattern to the curves. The only notable event on the trace is just after heel strike where for the left leg there is a transient change in direction of velocity.

An interpretation of these results will be given in the discussion chapter.

#### Sagittal and coronal plane knee angles

Software was written to calculate the angle

subtended by three CODA Landmarks. Application of Pythagorean theory to the problem of unknown lengths and use of the cosine rule allows for the calculation of the desired angles. (Extracting the necessary CODA data for each plane of motion). With reference to the knee, landmarks placed on the lateral malleolus, centre line of the knee joint and greater trochanter of the femur, the knee angle in the sagittal and coronal planes will be described, see figure 59. Clinically these are the angle of flexion of the knee, and the varus/valgus angle. Plots of these angles against time were drawn up for several volunteer subjects. These angles are arrived at using a very simplistic model of knee joint motion, ie. looking at it as a hinge joint. CODA produced angle /time plots very similar to those of Karповich (1960), Mitchelson (1977) and Annell et al (1982), which again were all using the simple hinge joint model for the knee.

The study of knee joint rotations has been very nearly exhausted, using a wide range of pieces of instrumentation. The limitations of using CODA are two fold , firstly the simplistic model that this software assumes and the movement of the markers over the skin. For gross deviations from the normal CODA could be used to produce a permanent record of events. However the author feels that using this particular method is of limited use in clinical gait analysis.

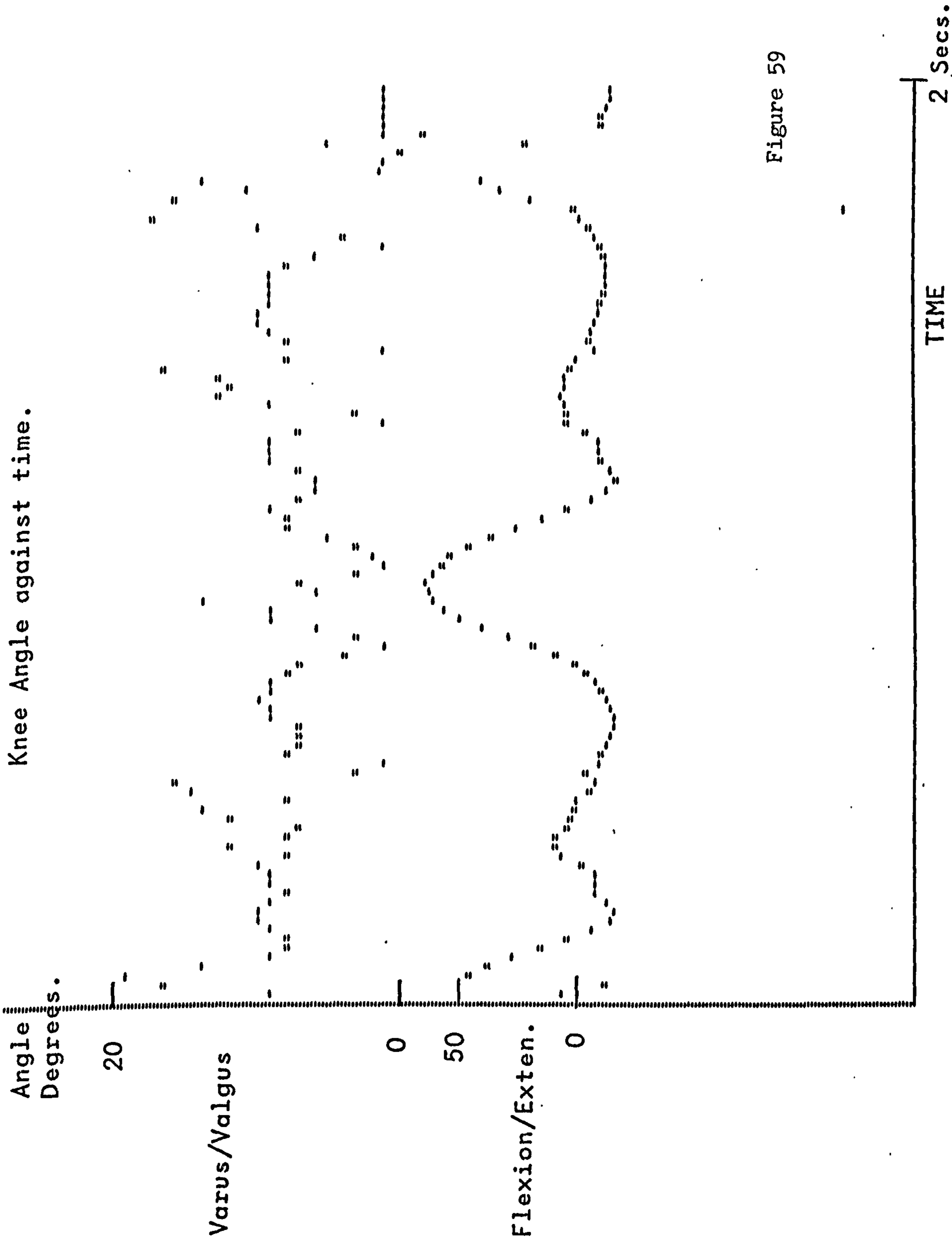

Figure 59

(The cpc problem can be alleviated by careful placement of the markers, which unfortunately is not always a practical solution).

#### Static knee dimensions

As with the vectorstereograph (Department of Human Morphology and Experimental Orthopaedics), CODA can be used to describe human anthropometric parameters. Pynsent et al (1983) used a computerised system incorporating a vector stereograph to locate the 3D position of 13 bony landmarks on the lower limb. From these values angles and dimensions of the knee joint were determined. Likewise CODA could be used in the same fashion, already being on-line to the laboratory computer and its software allowing the calculation of distances between points. The limiting factor when using CODA for this work would be that of accurate location of the CODA prisms on the bony landmarks.

Possible uses for such a method include study of knee dimensions in relation to knee pain (Pynsent 1983). Another area which could utilise the storage facility of the system is the setting up of a data base of anthropometric details of large populations.

In the ensuing discussion areas for application of this technique in Orthopaedics, Orthotics and



bioengineering will be discussed.

DISCUSSION.

## DISCUSSION

The following chapter discusses the results of the tests performed in relation to the objectives laid down at the outset of the project. These aims and objectives are listed below to allow a clearer assessment of how far the author has travelled towards achieving these objectives.

### Primary objective:-

To investigate whether the very precise measurement of gait can be used to identify the changes which arise in a joint quantitatively and reliably.

### Secondary objectives

To assess the new three dimensional tracking system (CODA-3)

To reproduce results of other workers using a unique system

Ascertain the parameters of use clinically

Investigate landmark fixation techniques and the

extent of their movement over skin.

Implications of the author's work will be discussed critically and suggestions for further areas of study in the light of these implications will be made. As the success of the primary objective is entirely dependent upon the fulfilment of the other objectives these will be discussed first. The author will then be in a position to talk about the conclusions and inferences she can make with regard to the fulfilment of the primary objective, ie. the use of precise measurements of gait in clinical practice. Little reference will be made to other work as the three dimensional tracking approach in gait analysis is a relatively new field, and the CODA-3 system has yet to be documented in the literature either for clinical use or in other applications.

Assessment of the new three dimensional tracking system

As the CODA-3 has been brought in as an untried tracking system, the first job the author had to tackle was that of checking it over as a piece of hardware. This took many months with the equipment being returned to its manufacturers on several occasions for debugging. The software associated with it was also upgraded, which again was only found to be necessary after the hiccups in it were found by the author.

These delays although an annoyance to the author and colleagues, were obviously a necessary part of the equipment development, and although not as a direct result of these problems there is now a total update on the system which has avoided many of the bugs inherent in CODA-3.

The importance of this testing period cannot be over emphasised. All too often this is carried-out after the experimentation, often resulting in invalid conclusions being drawn up.

Using the test rigs described, the CODA-3 system proved to be a very accurate piece of 3D tracking equipment. Using both stationary and moving prisms the output it produced matched the expected results as well as could be assessed. As the system had little software other than for data capture and numerical display, the first of the laboratory computer subroutines was written to allow capture and visualisation of the data. Using these the author discovered the unsuitability of the machine for tracking several slow moving prisms which were likely to come into cpc. The system in Nottingham when used for gait analysis was also shown to be suitable when tracking small numbers of markers.

For rapid oscillations such as the author was

expecting to see in the lax joint, the CODA-3 system was ideal, with acceleration noise in the region of 5-10 m/s/s.

In an attempt to reduce the incidence of cpc during gait analysis the use of a tibial plate for mounting the landmarks was investigated.

The system has hence proved to be very accurate, but is limited in this model by occurrence of cpc which cannot be overcome at the same time as retaining the high precision for which it was bought. For gait analysis we are limited by too small a number of markers to give simultaneous measurements of the kinematics of the whole lower limb. The problem of landmark movement, another limiting factor will be discussed in detail later.

#### Replication of results of other workers

One way of justifying the use of CODA was to compare the results it produced with that of another technique. The author was familiar with the work of D. Winter and so decided to set up a testing procedure in an attempt to replicate his findings. The author was aware of the discrepancies between the two tests but never the less was satisfied that CODA was capable of reproducing Winter's findings. CODA was also able to

draw the same conclusions as Inman et al (1983), about the technique by which increase in speed of locomotion is brought about. The effect of speed on velocity profiles was given in section 5.0 of the previous chapter, but cannot be supported by published literature as such results are not available. The reproducibility of gait patterns was good when using volunteers with no history of musculoskeletal disorders, however the applicability of this conclusion to patient gait patterns should be questioned.

#### Ascertaining the parameters of use clinically

However accurately a piece of equipment can measure three dimensional position it is of no use unless it can yield information of ultimate practical significance. In our case this application is that of clinical assessment, particularly in Orthopaedics (with special interest in the locomotor system).

It is the responsibility of the bioengineer to decide which of the parameters describable by his chosen technique, are going to be of use to the clinician.

The very precise measurements which CODA is capable of outputting associated with the small errors in positional information reported by its

manufacturers, was used to advantage in the analysis of marker movement. Velocity and acceleration profiles of the markers on the test rig proved to be very clean other than in periods of cpc. This idea was then extended to look at the velocity of landmarks sited on the lower limb during gait. It had been hypothesised that at points in the gait cycle of maximum joint loading, weakness in a joint would be highlighted, possibly by a slip/jerk movement of one or another other of the joint segments. It was also hypothesised that a sound knee will show an element of spring immediately after heel strike.

A normal pattern for velocity profile of landmarks sited on the lower limb was ascertained to allow comparison with patient data. The same parameters were then derived from data from a patient with two replacement joints, and the two sets of traces compared. One area of difference was particularly noticeable on MN's poor side which it is suggested is indicative of impaired function at the joint. A more sensitive measure, the calculation of acceleration profiles was also investigated, and made more sensitive still by choosing to look at the difference in acceleration between landmarks sited directly above and below the knee joint. Here differences were seen between normal and patient data at heel strike and mid-stance, supporting the hypothesis that this



parameter highlights weaknesses in a joint. To further test this hypothesis it would be necessary to monitor the serial dynamic response during gait of a knee joint. (in the case of knee replacement patients from pre operative to several months/ years post-operatively).

Investigation of landmarks fixation techniques and their movement over the skin

All techniques in gait analysis which employ surface markers are subject to the introduction of error as a result of movement of the markers over the skin and relative to underlying bone, whose movement they are tracking. There is no easy way of quantifying these movements, but the movement of the marker over skin can be reduced by firm attachment of the markers. The best combination of strapping and taping was investigated by the author. The most suitable combination, ie Velcro and double sided adhesive tape, was then used when collecting gait data.

These attachment techniques could not however take into account the different skin types which present themselves. Secondly intersubject differences in the extent of these two types of marker movement arise because of the often unusual bone/skin relationships in diseased and prosthetic joints.

From the experimentation carried-out it was concluded that marker movement relative to underlying bone does take place, but that the extent of movement varies widely between subjects. In part the variability can be put down to the two factors mentioned above. The author came across only one paper (Townsend et al 1977), which quantified this movement. Although this quantification of landmark movement will not allow the author to introduce an error factor to take account of it, she does feel satisfied that the reader has been made aware of the problem, and will bear the phenomenon in mind. Obviously if this movement had been too large then use of CODA in gait analysis would have to have been seriously questioned.

#### Suggestions for further work

Bearing in mind the limitations brought about by the cross point conflict condition, the author has investigated other areas of work for which CODA-3 could prove useful. In the field of Ergonomics, CODA has been used to track the movements of the arm to produce a data base of reach envelopes. It is presently being used in Nottingham to track arm movements of check out operators who are using the bar coding system of pricing goods. This work is being done to assess the possible areas for improvement of design of the checkouts.

Preliminary investigations have been made using our CODA-3 system looking at head and neck movements during the sit/stand action.

The movements of the pelvis and spine, of interest to those involved in research on scoliotic children, can be tracked using CODA. Pilot studies are under way by a research physiotherapist, to test the efficacy of such a project.

All of the above have to take care to avoid error and often compromise in their choice of sites for the location of the CODA landmarks. The advantage of the updated system is obvious in these cases and more so if we were wanting to track slow moving events.

The author has made tentative suggestions to those involved in rehabilitation about the possibility of using CODA as an aid to those patients who would benefit from feedback about the success or otherwise of body displacements that they are trying to bring about eg. in stroke and amputee patients who are relearning the art of walking. Those involved with patient care thought this would be of practical help to such patients, so this is one more application for the CODA-3 system. The concluding remarks made in the final chapter bring together the authors final thoughts on the CODA-3 system and it's applicability in clinical

assessment.

CONCLUSIONS.

## CONCLUSIONS

The objective of this project was to investigate whether the very precise measurement of gait could be used to identify changes which arise in a joint. The criterion being that this should be done quantitatively and reliably.

CODA-3, the technique made available to the author, proved itself capable of producing very accurate three dimensional information about the position of its set of prismatic landmarks. It allowed the collection of parameters of gait which compared favourably with those acquired using a cinematographic technique. The main advantages of using this system were firstly the real time data analysis facility and the ease of attachment and wearing of the prismatic markers.

By a radiographic technique the author showed that, as with all surface mounted markers, the CODA-3 landmarks moved over the skin relative to underlying bone. She pointed out that this must always be borne in mind when drawing conclusions from data collected using CODA-3.

The displacements, velocities and accelerations of

CODA markers located at various sites on the lower limb were determined. Neither the displacements nor the velocities proved useful in highlighting abnormalities within a joint. The more sensitive parameter acceleration was then investigated.

The results obtained from further studies would suggest that by monitoring the linear accelerations of landmarks mounted around the knee joint an indication of joint condition can be obtained. The parts of the gait cycle where there was a difference in acceleration between landmarks located above and below the knee joint were heel strike and single support. The limitation imposed by the cross point conflict prevented the author from describing the kinematics of the joint for the whole of the gait cycle. From the results it is concluded, that at points in the gait cycle of maximum joint loading, weaknesses in a joint are likely to be highlighted. Using the update on the CODA-3 system this theory could be tested for a whole range of patients with damaged knee joints, the reduction in occurrence of cpc allowing the whole gait cycle to be monitored without interruption.

A few examples are given of other applications for CODA, both clinical and non-clinical, several of which have already undergone pilot studies. The suitability of the Department of Orthopaedic's CODA-3 as a tool in

clinical assessment is questioned because of the loss of data which takes place during the periods of cpc. Slow movements, as are seen in many of the patients attending rehabilitation therapy, are not suited to scrutinisation by CODA-3, but the system must now be tested to see if it can pick up those alterations in the kinematics of the joint before they are quantifiable by the clinician. Obviously, more work is needed in collaboration with clinical personnel, to identify other parameters which will be of use in identifying joint abnormalities.

It can be concluded that precise measurements of gait are of use in the identification of joint abnormalities but further investigations are necessary in order that these tests can be used in routine clinical assessment.



APPENDIX A

# FLOWCHART FOR MAIN CODA PROGRAMME.

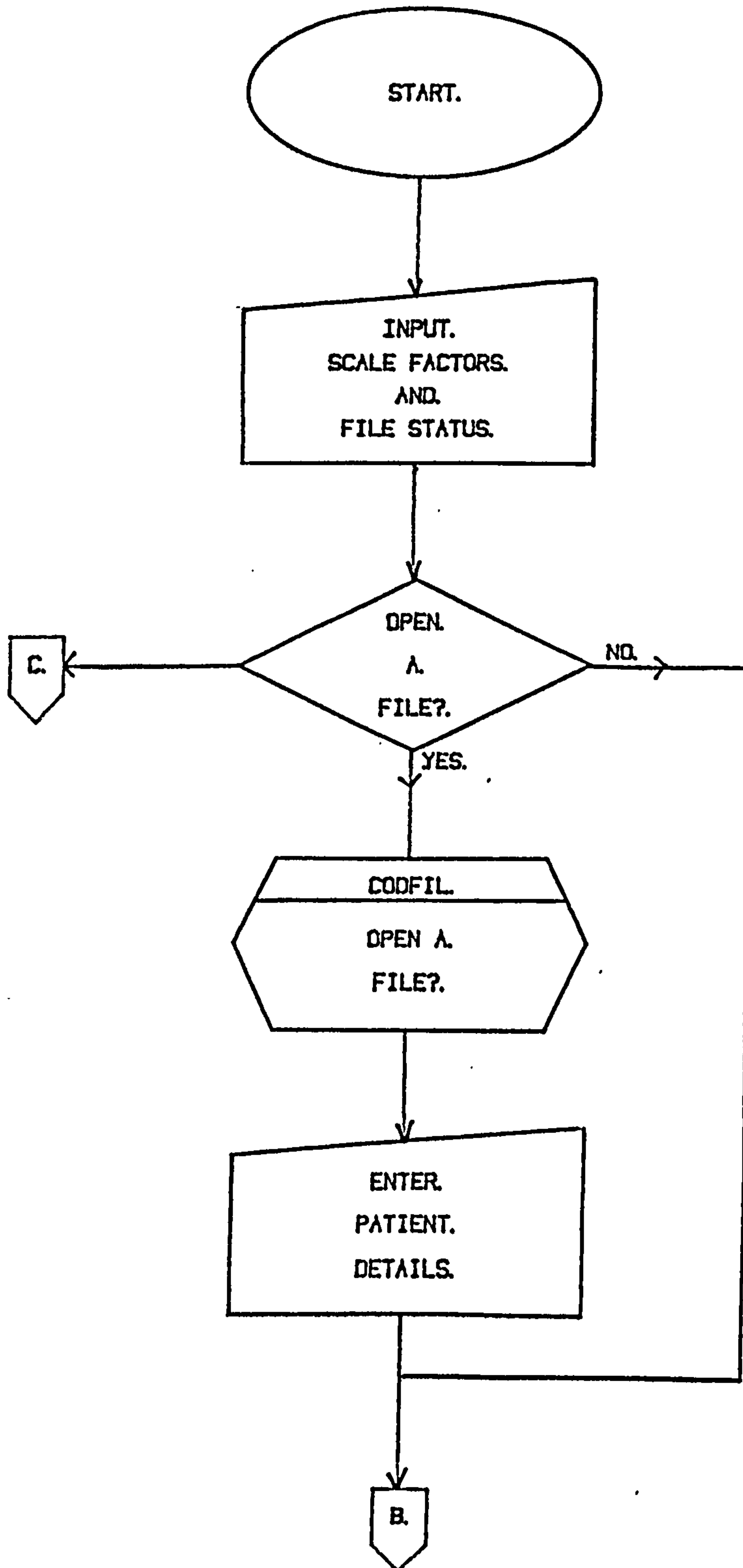

# FLOWCHART FOR MAIN CODA.

(CONTINUED).

L

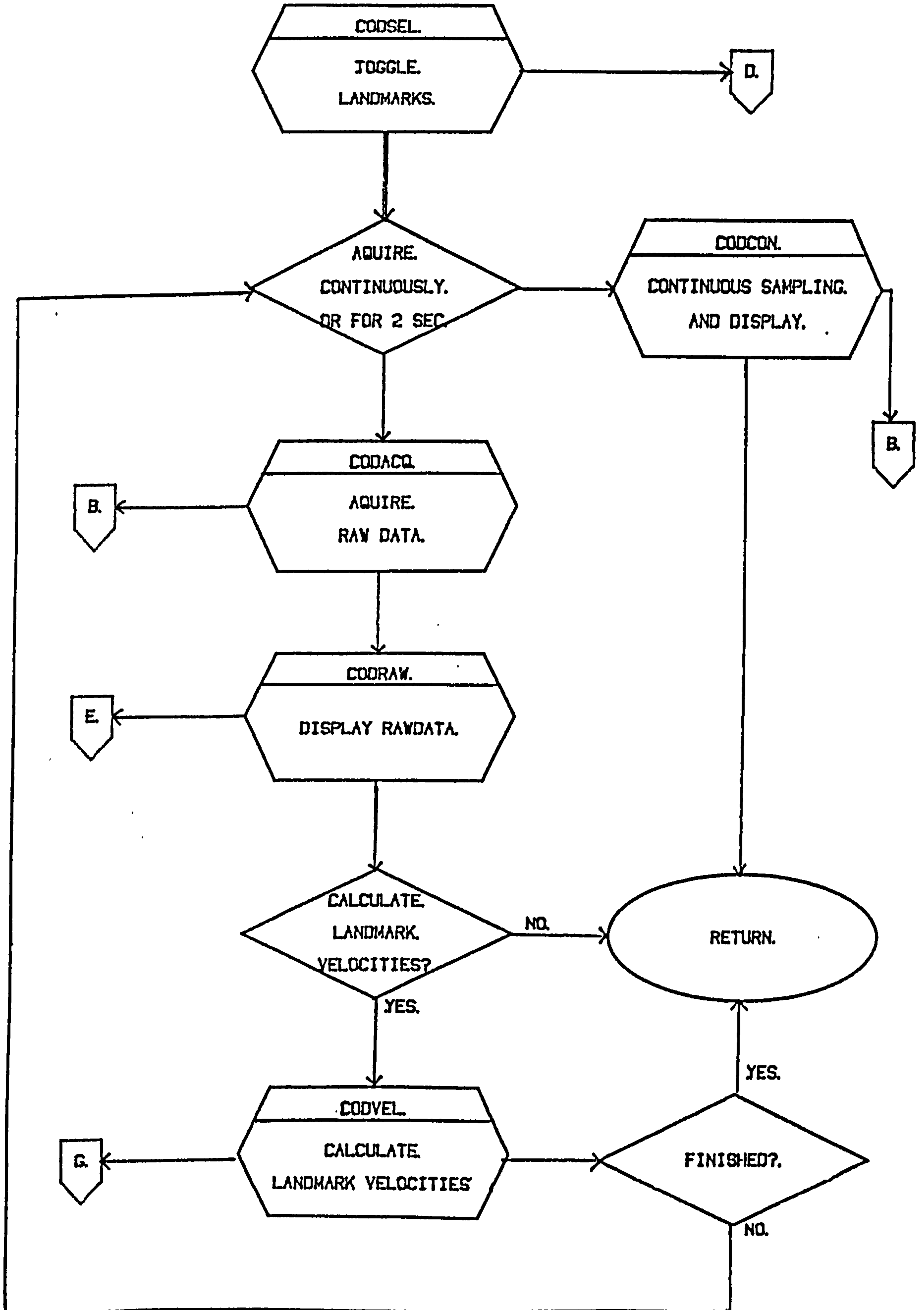

CONTINUOUS SAMPLING SUBROUTINE.

FLOWCHART.

B

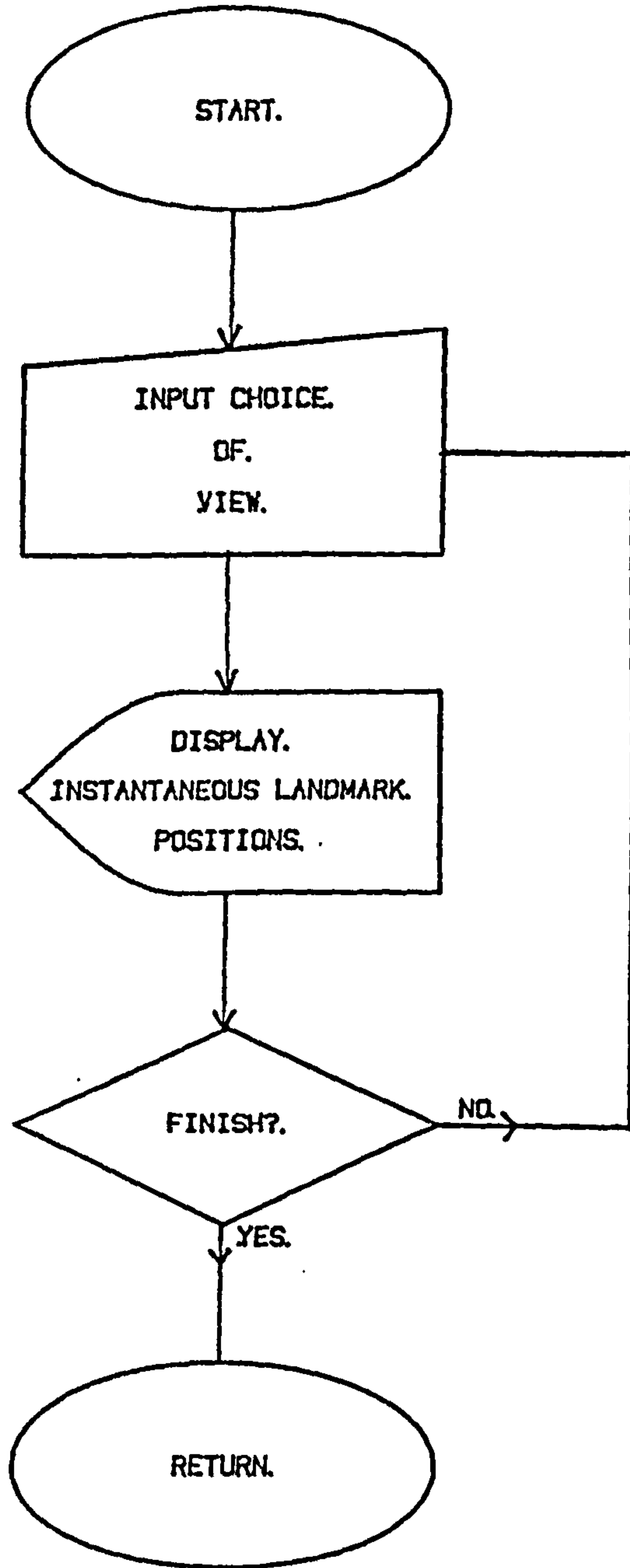

# VELOCITY PROFILE SUBROUTINE.

## FLOWCHART.

G

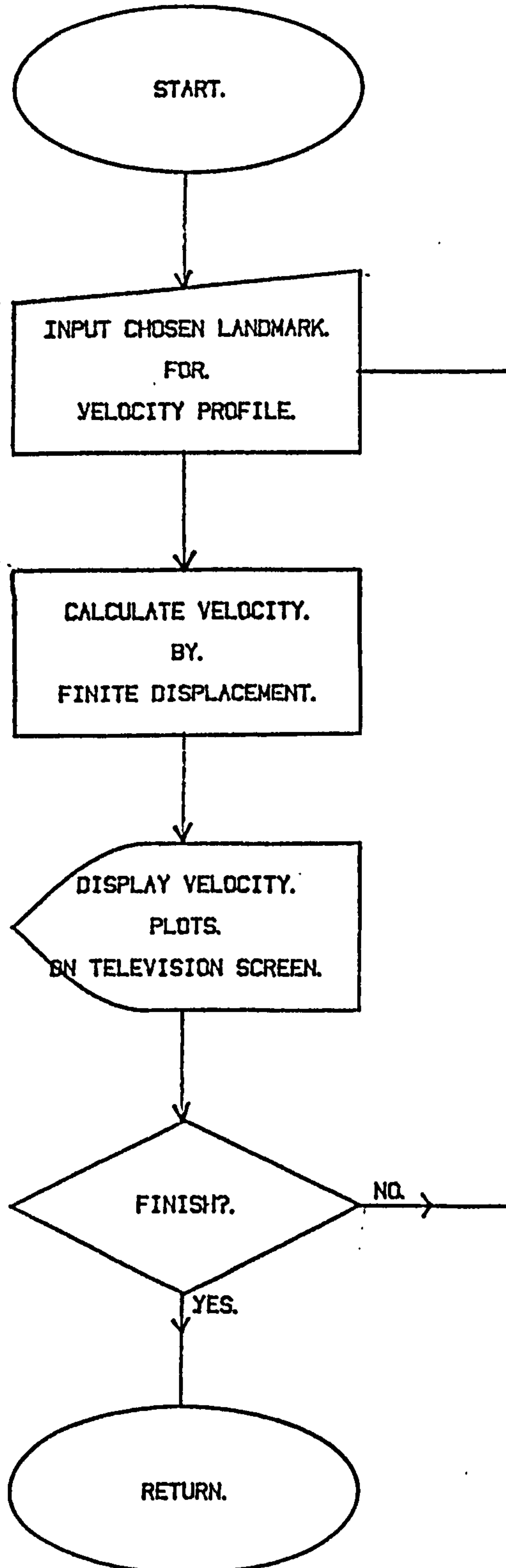

# DATA AQUISITION SUBROUTINE.

## FLOWCHART.

J

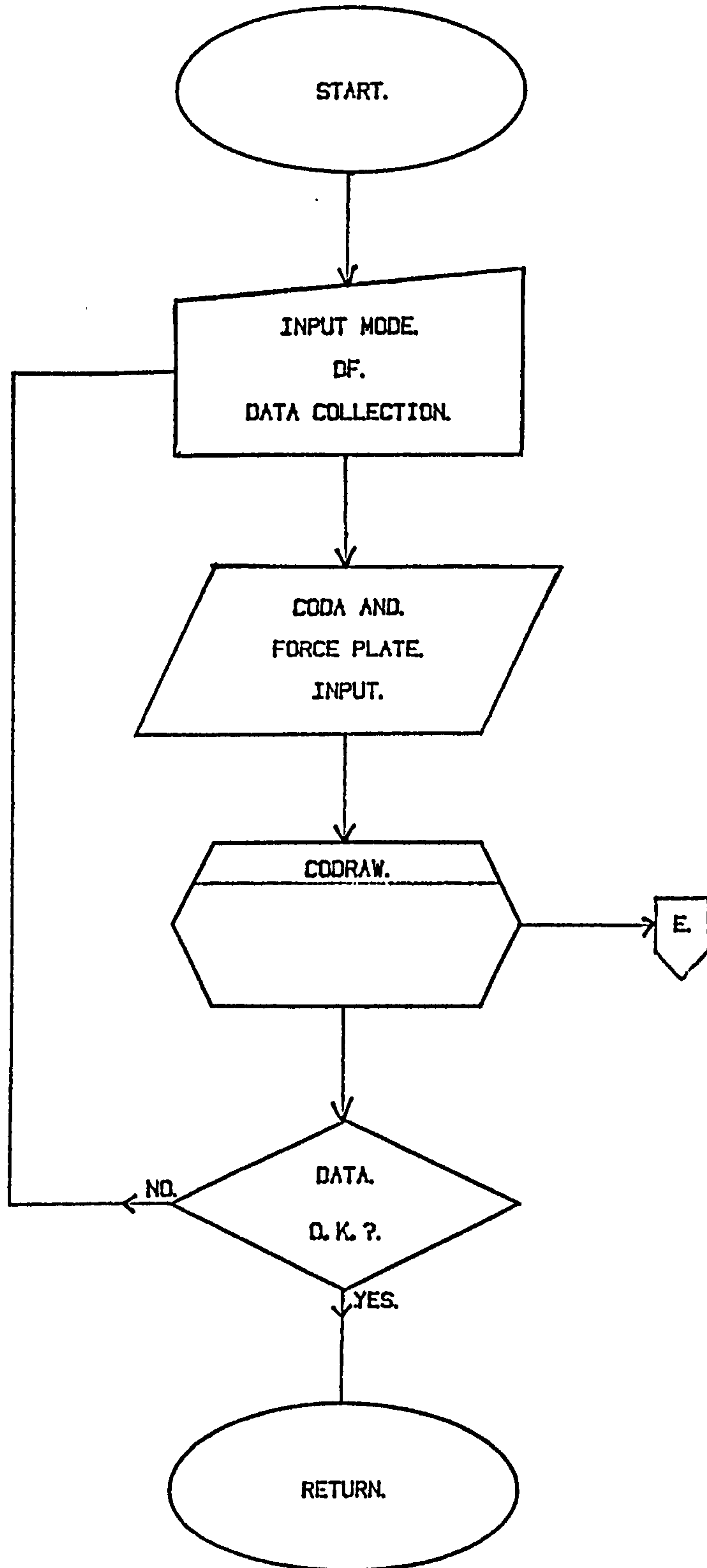

# LANDMARK TOGGLING SUBROUTINE.

## FLOWCHART.

D.

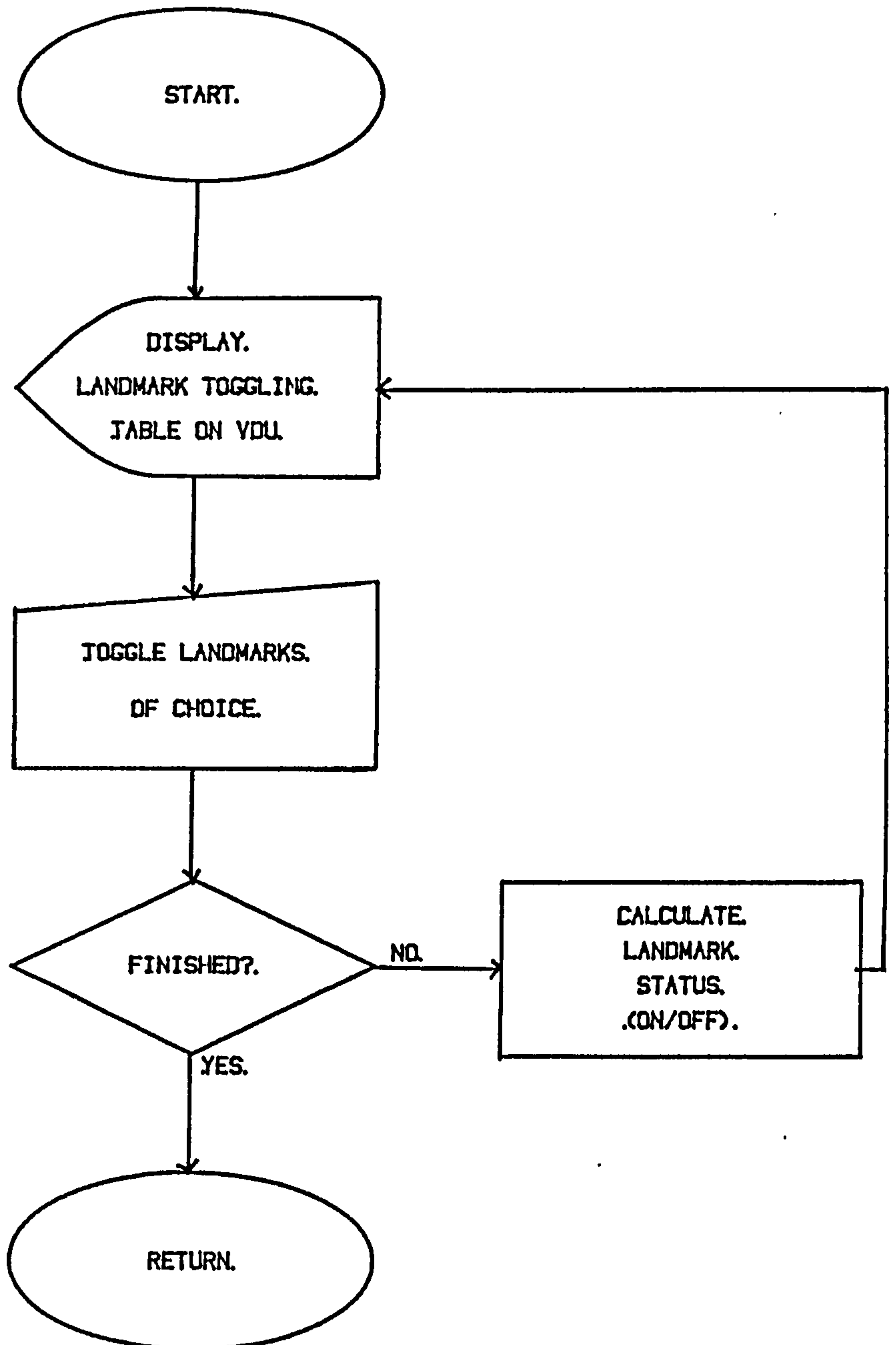

# OPEN FILE SUBROUTINE.

## FLOWCHART.

C

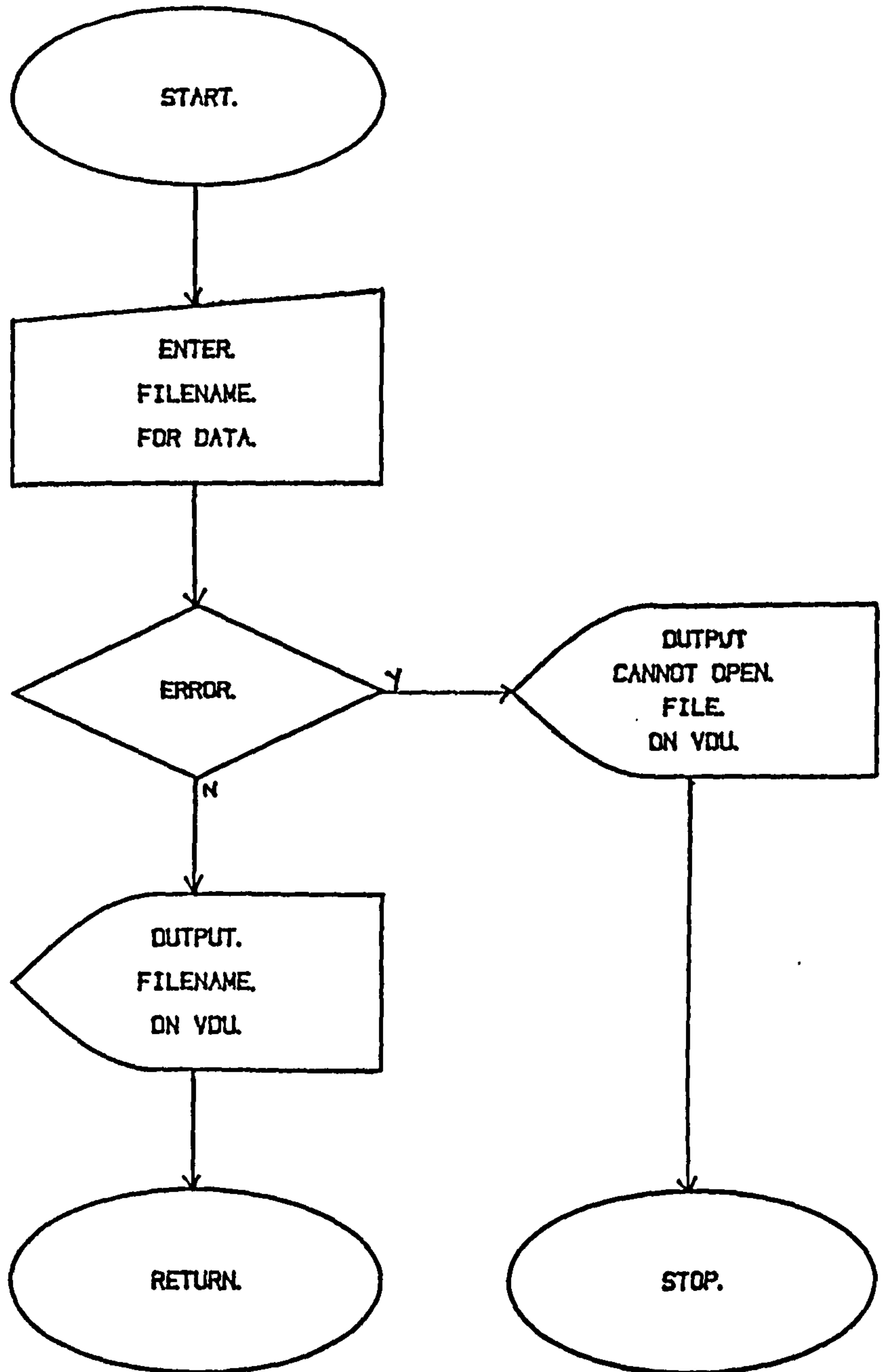



# FLOWCHART FOR PLOTTER OUTPUT.

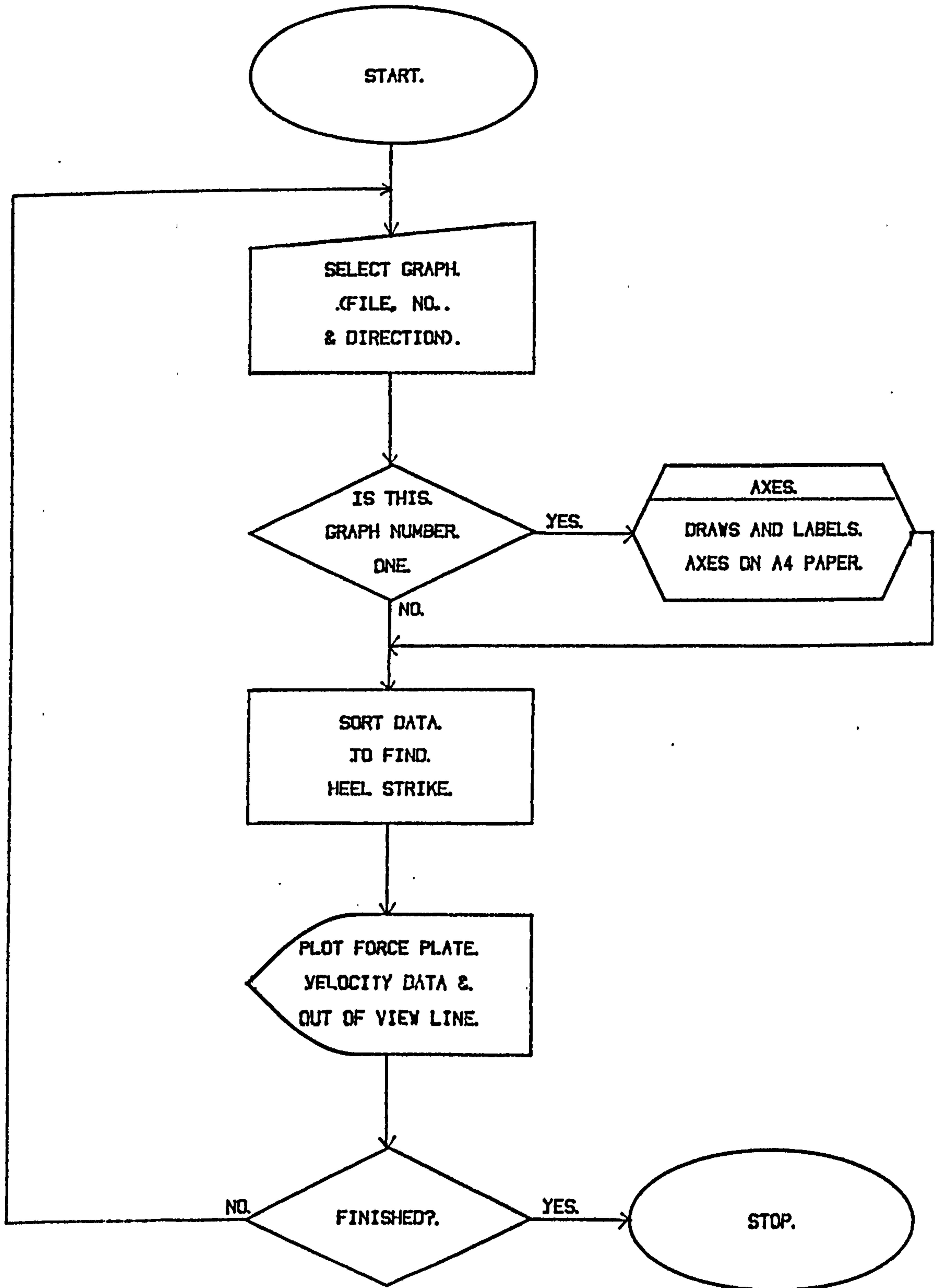

APPENDIX B

**BEST COPY**

**AVAILABLE**

TEXT IN ORIGINAL IS  
CLOSE TO THE EDGE OF  
THE PAGE

```

BLOCK DATA
BYTE FILEN(15),IFIL
BYTE NAME(80),DOB(10),SEX(2),LEG(2),DATE(10),TEST(80)

COMMON /RAWDAT/ IDCODA(4801),IDF(1200),INVIEW(200),ISCALE
COMMON /SELECT/ ISEL(9),JOINED(8,8),IFROT
COMMON /PATIEN/ NAME,DOB,IHGT,IWGT,SEX,LEG,DATE,NRUN,TEST
COMMON /FIL/ NREC,FILEN,IFIL
COMMON /AXES/ IDAT(25),VUFS,ANGVEC(3),UVW(3,3),R(3),
CC1(3,3),CC2(3,3),RXYZ(24),RUW(24),ILLM(8)
1
DATA ISEL/1,1,1,0,0,1,1,0/ !Landmarks 'on' at start
DATA ILLM/1,2,8,7,4,3,5,6/ !Logical to actual landmark map
END

PROGRAM CODA
BYTE FILEN(15),IFIL
BYTE NAME(80),DOB(10),SEX(2),LEG(2),DATE(10),TEST(80)

COMMON /RAWDAT/ IDCODA(4801),IDF(1200),INVIEW(200),ISCALE
COMMON /SELECT/ ISEL(9),JOINED(8,8),IFROT
COMMON /PATIEN/ NAME,DOB,IHGT,IWGT,SEX,LEG,DATE,NRUN,TEST
COMMON /FIL/ NREC,FILEN,IFIL
COMMON /AXES/ IDAT(25),VUFS,ANGVEC(3),UVW(3,3),R(3),
CC1(3,3),CC2(3,3),RXYZ(24),RUW(24),ILLM(8)
1
CALL INIT(1,1,4000) !Initialise macros (graphic screen)
CALL PENCIL !Invert pen and background colours
CALL BAKCOL

TYPE 1
FORMAT('What scale factor will you use (-,2,5,-0) ? ')
ACCEPT 2, ISCALE
FORMAT(I3)
IF( ISCALE .NE. 1 .AND. ISCALE .NE. 2 .AND.
1 ISCALE .NE. 5 .AND. ISCALE .NE. 10 ) ISCALE = 1

Open a file ( if desired )
IDU = 0
TYPE 3
FORMAT('Press return to open a file or enter 1 for no file: ')
ACCEPT 4,IGO
FORMAT(I3)
IF(IGO.EQ.0) CALL CODFIL(IDO)
CALL CODSEL

!In option menu

TYPE 11
FORMAT(' ',//)
1 CODA acquisition and analysis. M Harvey, J Towie October 1983, //,
1 1. Enter patients' details', //,
1 2. Acquire data', //,
1 3. Display raw data (called automatically)', //,
1 4. Define axes', //,
1 5. Tibial rot.', //,
1 6. Continuous sampling and graphic display', //,
1 7. Line display of recorded data', //,

1 8. Distance between landmarks', //,
1 9. Recall from disc', //,
1 10. Stop', //,
1 11. Select landmarks for analysis', //,
1 12. Type raw CODA data', //,
1 13. Type raw force plate data', //,
1 14. Type velocities', //, //,
1 'What next ? ')

ACCEPT 2,INXT
GOTO(100,200,300,400,500,600,700,800,900,1100,1200,1300)
1 -400),INXT
GOTO 10

CONTINUE
CALL COMPAT
GOTO 10

!Patient data

CALL CODACC
CALL CODRAW
IF(IDU.EQ.0) GOTO 10
TYPE 201
FORMAT('Enter -1 to discard, 0 to keep, 1 to retry: ')
ACCEPT 2, IGO
IF(IGO.LT.0) GOTO 10
IF(IGO.GT.0) GOTO 200
CALL CODSAV
GOTO 10

300 CALL CODRF4
GOTO 10

400 CALL CODAXS
GOTO 10

500 CALL CODTIB
GOTO 10

600 CALL CODCON
GOTO 10

700 CALL CODLIN
GOTO 10

800 CALL CODDIS
GOTO 10

900 CALL CODREC
GOTO 10

1000 CALL EXIT(0)

1100 CALL CODSEL
GOTO 10

1200 TYPE 1201, IDCODA
1201 -URMAT(' ',2(4(3(6,-X),//))
GOTO 10

1300 TYPE 1301, IDFF
1301 -URMAT(' ',4(6,2X,16,2X,16)

```

```
0 CALL COUVEL
  GO TO 10
  END
```

```
!Velocity calculations
```

```
QUANTUM COUVEL
```

```
COMMON /SELECT/ ISEL(9),JOINED(8,8),IPROT
```

```
200 TYPE 201,ISEL
```

```
201 FORMAT(/,' 0 - not selected, 1 = selected. (9 = force platform  
1, landmark no. //  
1, 2, 3, 4, 5, 6, 7, 8, 9, //  
1, 9.2, //,  
: Enter landmark no. to toggle (0 to finish).')
```

```
202 ADD=1 204, ... !type in landmark or choice  
  FORMAT(12)
```

```
IF(ILM.(0) F(10 999 !Check for mistakes  
IF( ... !GOTO 200
```

```
ISEL(ILM) = ... !Logical landmark number  
GOTO 200
```

```
999 RETURN  
  END
```



```

4000          CONTINUE
4001          FORMAT(17)
          Display data
          Start with landmark no. one
          IMASK = 128
          DO 4200 I=1,24
            IF(ISEL((I+2)/3).EQ.0) GOTO 4150
            RSCALE = 50. / (RSCALE(I)*RSCALE)
            IDT = IDCODA(I)
            IX = IXORG(I)
            IY = IYORG(I) + NINT( RSCALE * ( IDT - IDT0 ) )
            IF(IDT.LI.EYMIN(I) .OR. IYMAX(I).LI.IDT) IY = IYORG(I)
            CALL MOVPT(IX,IY)
          I MOVE pen there
          IT = I + 24
          DO 4100 J=1,100
            IDT = IDT0 + J
            IY = IYORG(I) + NINT( RSCALE * ( IDT - IDT0 ) )
            IT = IT + 48
            IX = IX + 1
            IF(IDT.LI.EYMIN(I) .OR. IYMAX(I).LI.IDT) GOTO 4100
            CALL MOVE(IX,IY)
            CONTINUE
          IF((I/3)*2.EG.1) IMASK = IMASK/C
          IMASK = IMASK*2
          CONTINUE
          Display 'in view' lines
          IMASK = 128
          DO 4400 I=1,24
            IF(ISEL((I+2)/3).EQ.0) GOTO 4350
            RSCALE = 50. / (RSCALE(I)*RSCALE)
            IX = IXORG(I)
            IY = IYORG(I) - 2
            CALL MOVPT(IX,IY)
          IT = I + 24
          DO 4300 J=1,100
            IT = IT + 48
            IX = IX + 1
            IF(INVIEW(J*2-1).AND.IMASK) GOTO 4250
            CALL MOVPT(IX,IY)
            GOTO 4300
            CALL MOVE(IX,IY)
            CONTINUE
          IF((I/3)*3.EQ.1) IMASK = IMASK/2
          CONTINUE
          Display force performance data
          IF(ISEL(9).EQ.0) GOTO 5300
          DO 5200 I=25,32
            RSCALE = 50. / (RSCALE(I)*RSCALE)
            IDT = IDFP(I-24)

```

The scaling of these graphs has been altered  
Note the factor of four in rscale and iofs







```

5      IMASK=IMASK/2
7      CONTINUE
52     PAUSE 'Press return to continue'
      TYPE 252
      FORMAT(' ')
      CALL ERASE
      DO 259 I=1,2
          !Labeling axes
          IX=IXORG(I)
          IY=IYORG(I)+490
          CALL MOVPT(I,IX,IY)
          IY=IYORG(I)
          CALL LINE(IX,IY)
          IX=IXORG(I)+400
          IY=IYORG(I)+244
          CALL MOVPT(I,IX,IY)
          IX=IXORG(I)
          CALL LINE(IX,IY)
          IX=IXORG(I)+200
          IY=IYORG(I)+234
          CALL MOVPT(I,IX,IY)
          IY=IYORG(I)+244
          CALL LINE(IX,IY)
          ENCODE(5,558,TEXT)
          CALL STRING(TEXT,5,2,490)
          FORMAT('2000')
          CONTINUE
          ENCODE(4,260,TEXT)
          CALL STRING(TEXT,4,6,397)
          FORMAT('mm/s')
          ENCODE(5,461,TEXT)
          CALL STRING(TEXT,5,2,490)
          FORMAT('2000')
          ENCODE(17,462,TEXT)
          CALL STRING(TEXT,17,245,500)
          FORMAT('VELOCITIES Y-dir.')
```

```

          I=2 !Scale=s etc. for second graph
          I1=1/24+1
          IDI=DVI(I1)
          RSCALE=488./((ISCAL(I))*ISCALE)
          IX=IXORG(I)
          IY=IYORG(I)+NINT(RSCALE*(IDI-IOFFS(I)))
          IF(IDI.LT.IYMIN(I).OR.IYMAX(I).LT.IDI)GOTO 267
          CALL MOVPT(IX,IY)
          IT=I1+2
          TYPE 265
          FORMAT(' The IY values for Y are',/,)
          DO 271 J=1,99
              IF(DVI(IT).GE.31000)GOTO 269
              IDI=DVI(IT)
              IY=IYORG(I)+NINT(RSCALE*(IDI-IOFFS(I)))
              IT=I1+2
              IX=IX+4
              IF(IDI.LT.IYMIN(I).OR.IYMAX(I).LT.IDI)GOTO 267
              CALL LINE(IX,IY)
              IY=268,IY,215,' ')
              GOTO 271
          TYPE 270,IY
          FORMAT('s',15,'*')
          CONTINUE
          IT=I1+2
```

```

271     CONTINUE
      IMASK=128
      DO 264 I=1,24,3
          IF(ISEL((I+2)/3).EG.0)GOTO 263
          RSCALE=488./((ISCAL(I))*ISCALE)
          IX=40
          IY=226
          CALL MOVPT(IX,IY)
          IT=I+24
          DO 262 J=1,100
              IT=IT+48
              IX=IX+4
              IF(INVIEW(J*2-I).AND.IMASK)GOTO 261
              CALL LINE(IX,IY)
              GOTO 262
          CALL MOVPT(IX,IY)
          CONTINUE
          IMASK=IMASK/2
          CONTINUE
          PAUSE 'Press return to continue'
```

```

      CALL ERASE
      DO 261 I=1,2
          IX=IXORG(I)
          IY=IYORG(I)+490
          CALL MOVPT(IX,IY)
          IY=IYORG(I)
          CALL LINE(IX,IY)
          IX=IXORG(I)+400
          IY=IYORG(I)+244
          CALL MOVPT(IX,IY)
          IX=IXORG(I)
          CALL LINE(IX,IY)
          IX=IXORG(I)+200
          IY=IYORG(I)+234
          CALL MOVPT(IX,IY)
          IY=IYORG(I)+244
          CALL LINE(IX,IY)
          ENCODE(5,275,TEXT)
          CALL STRING(TEXT,5,2,490)
          FORMAT('3500')
```

```

          CONTINUE
          ENCODE(17,470,TEXT)
          CALL STRING(TEXT,17,245,500)
          FORMAT('VELOCITIES Z-dir.')
```

```

          ENCODE(4,471,TEXT)
          CALL STRING(TEXT,4,6,397)
          FORMAT('mm/s')
          ENCODE(5,472,TEXT)
          CALL STRING(TEXT,5,2,490)
          FORMAT('3500')
          CONTINUE
          ENCODE(17,470,TEXT)
          CALL STRING(TEXT,17,245,500)
          FORMAT('VELOCITIES Z-dir.')
```

```

          ENCODE(4,471,TEXT)
          CALL STRING(TEXT,4,6,397)
          FORMAT('mm/s')
          ENCODE(5,472,TEXT)
          CALL STRING(TEXT,5,2,490)
          FORMAT('3500')
          CONTINUE
          ENCODE(17,470,TEXT)
          CALL STRING(TEXT,17,245,500)
          FORMAT('VELOCITIES Z-dir.')
```

```

          ENCODE(4,471,TEXT)
          CALL STRING(TEXT,4,6,397)
          FORMAT('mm/s')
          ENCODE(5,472,TEXT)
          CALL STRING(TEXT,5,2,490)
          FORMAT('3500')
          CONTINUE
          ENCODE(17,470,TEXT)
          CALL STRING(TEXT,17,245,500)
          FORMAT('VELOCITIES Z-dir.')
```



```

SUBROUTINE COUCON
!Continuous sampling and c 57.99
INTEGER IX(8),IY(8)
BYTE TEXT(10),IVF(8),DONE
COMMON /SE-ECT/ ISEL(9),JOINED(8,8),IFROT
COMMON /AXES/ IDAT(25),VOFFS,ANEVEC(2),UVW(C,3),G(3),
1 DCI(5,3),DC2(5,3),RXYZ(24),XUVW(24),--LM(8)
DATA TEXT(10)/0/
DATA IVF/28,64,32,16,8,4,2,1/
DONE = .FALSE.
DO 10 I=1,8
JOINED(I,I) = ISEL(I)
CONTINUE
Which view
TYPE 21
FORMAT(' Enter',/)
1 , 1 View from CODA',//
1 , 2 View from start of walk',//
1 , 3 View from top',//
ACCEPT 22,IG0
-ORMAT(13)
IF(IG0.LT.1.0R.IG0.GT.3) IGO = 1
K1 = 3
K2 = 2
IF(IG0.EQ.2) K1 = 1
IF(IG0.EQ.3) K2 = 1
CALL ERASE
TYPE 101, ((JOINED(I,J),J=1,2),I=1,8)
FORMAT(' Joined:',//,
1 , 1: 1,12,/,
1 , 2: 2,12,/,
1 , 3: 3,12,/,
1 , 4: 4,12,/,
1 , 5: 5,12,/,
1 , 6: 6,12,/,
1 , 7: 7,12,/,
1 , 8: 8,12,/,
1 , To: 1 2 3 4 5 6 7 8',/)
TYPE 102
FORMAT('Enter landmark numbers to link or unlink (2 numbers) : ')
IT = IITINK(0)
IF(IT.LT.0) GOTO 200
IT =,IT .AND. *377
IF(IT.NE.13.AND.IT.NE.10) GOTO 120
DONE = .TRUE.
GOTO 200
ACCEPT 121, IL1,IL2
-ORMAT(213)

```

!Ascii value of 0 = 48

```

GOTO 1
JOINED(IL1,IL2) = 1 - JOINED(IL1,IL2)
JOINED(IL2,IL1) = JOINED(IL1,IL2)
IF(ALL.EG.IL2) ISEL(IL2) = JOINED(IL2,IL1)
GOTO 1
CALL COUIMP(CUBA)
!Callen CUMA data
DO 500 I=0,7
IX(I+1) = IDAT(3*I+K1)/4+6
IY(I+1) = IDAT(3*I+K2)/4+6
CONTINUE
DO 1100 I=1,8
IF( ISEL(I) .EQ. 0 ) GOTO 1100
CALL MOVPT(X(I),IY(I))
I1 = I-1
DO 1000 J=1,I1
IF( ISEL(J) .EQ. 0 ) GOTO 1000
IF( JOINED(I,J) .EQ. 0 ) GOTO 1000
CALL MOVPT(X(I),IY(I))
CALL LINK(X(J),IY(J))
CONTINUE
CONTINUE
IF(DONE) RETURN
DRAW using PLOT 512 software the position of the landmarks
CALL PENCOL
DO 2100 I=1,8
IF( ISEL(I) .EQ. 0 ) GOTO 2100
CALL MOVPT(X(I),IY(I))
I1 = I-1
DO 2000 J=1,I1
IF( ISEL(J) .EQ. 0 ) GOTO 2000
IF( JOINED(I,J) .EQ. 0 ) GOTO 2000
CALL MOVPT(X(I),IY(I))
CALL LINK(X(J),IY(J))
CONTINUE
CONTINUE
CALL PENCOL
GOTO 110
RETURN
END

```

!Ascii value of 0 = 48







## PROGRAMME BTATIS

```

C calculates the sum and mean of a group of numbers
C      "      "      standard deviation
C      "      "      student t value for unpaired samples

REAL Y(50)
REAL X(50)
TYPE 10
10  FORMAT(' MEAN STANDARD DEVIATION STUDENT T CALCULATION:')

TYPE 20
20  FORMAT(' ENTER NO. OF NUMBERS N:')      !User specifies
ACCEPT 30,N
30  FORMAT (I3)

TYPE 35
35  FORMAT(' ENTER NO. OF NUMBERS M:')      !As above
ACCEPT 38,M
38  FORMAT(I3)

C IF (N.LE.0) STOP      !Terminator

TYPE 40
40  FORMAT('DO NOT FORGET THE DECIMAL PT:')

TYPE 50
50  FORMAT(' TYPE IN NUMBERS FOR X:')
ACCEPT 100,(X(J),J=1,N)
100 FORMAT(F9.3)

TYPE 150
150 FORMAT(' TYPE IN NUMBERS FOR Y:')
ACCEPT 160,(Y(K),K=1,M)
160 FORMAT(F9.3)

SUM=0.0
DO 200 J=1,N
    SUM=SUM+X(J)
200 CONTINUE

SES=0      !Sum of the (x)**2
DO 210 J=1,N
    SES=SES+(X(J))**2
210 CONTINUE

ASUM=SUM/N
SSUM=SUM**2      !Sum squared for x
ASSU=SSUM/N      !Sum squared over n
STD=SQRT((SES-ASSU)/(N-1))      !Standard deviation

BUM=0.0      !Similar calculations for y
DO 400 K=1,M
    BUM=BUM+Y(K)
400 CONTINUE

BES=0.0
DO 410 K=1,M
    BES=BES+(Y(K))**2
410 CONTINUE

BSUM=BUM/M      !Sum squared for y

```



CSUM=BUM\*\*2

CSSU=CSUM/M

SDD=((SES-ASSU)+(RES-CSSU))/((N-1)+(M-1))

SE=SQRT((SDD/N)+(SDD/M))

T=((SUM)/N)-((BUM)/M)/SE

230 TYPE 230,N,M !Print out of results  
FORMAT(' NOS. IN SAMPLES ARE =',2I4)

250 TYPE 250,SUM,BUM  
FORMAT(' SUMS ARE =',2F10.3)

300 TYPE 300,ASUM,BSUM  
FORMAT(' AVERAGES ARE =',2F10.3)

330 TYPE 330,SSUM,CSUM  
FORMAT(' SUM SQUARED ARE =',2F14.3)

350 TYPE 350,STD,SDD  
FORMAT(' STANDARD DEVIATIONS ARE =',2F10.3)

500 TYPE 500,T  
FORMAT(' t FOR THIS UNPAIRED SAMPLE IS=',F6.3)  
END

CALCULATIONS USED IN DETERMINATION OF  
LANDMARKS VELOCITIES.

For example in the x-direction:-

Let  $x_1$ ,  $x_2$ ,  $x_3$  be the x co-ordinates of three successive positions of a landmark, at intervals of  $t$  seconds.

Then velocity of the landmark is as follows:-

$$((x_3-x_2)/t + (x_2-x_1)/t) / 2 = (x_3-x_1)/2t$$

DETERMINATION OF KNEE ANGLES (CORONAL AND  
SAGITTAL PLANE) FROM LANDMARK POSITION.

For example, in the sagittal plane three landmarks sited to define the long axes of the calf and thigh, with x and y distances as detailed below. Using Pythagorean theory and the cosine rule the angle at the knee joint sampled at 0.01 second intervals can be described.

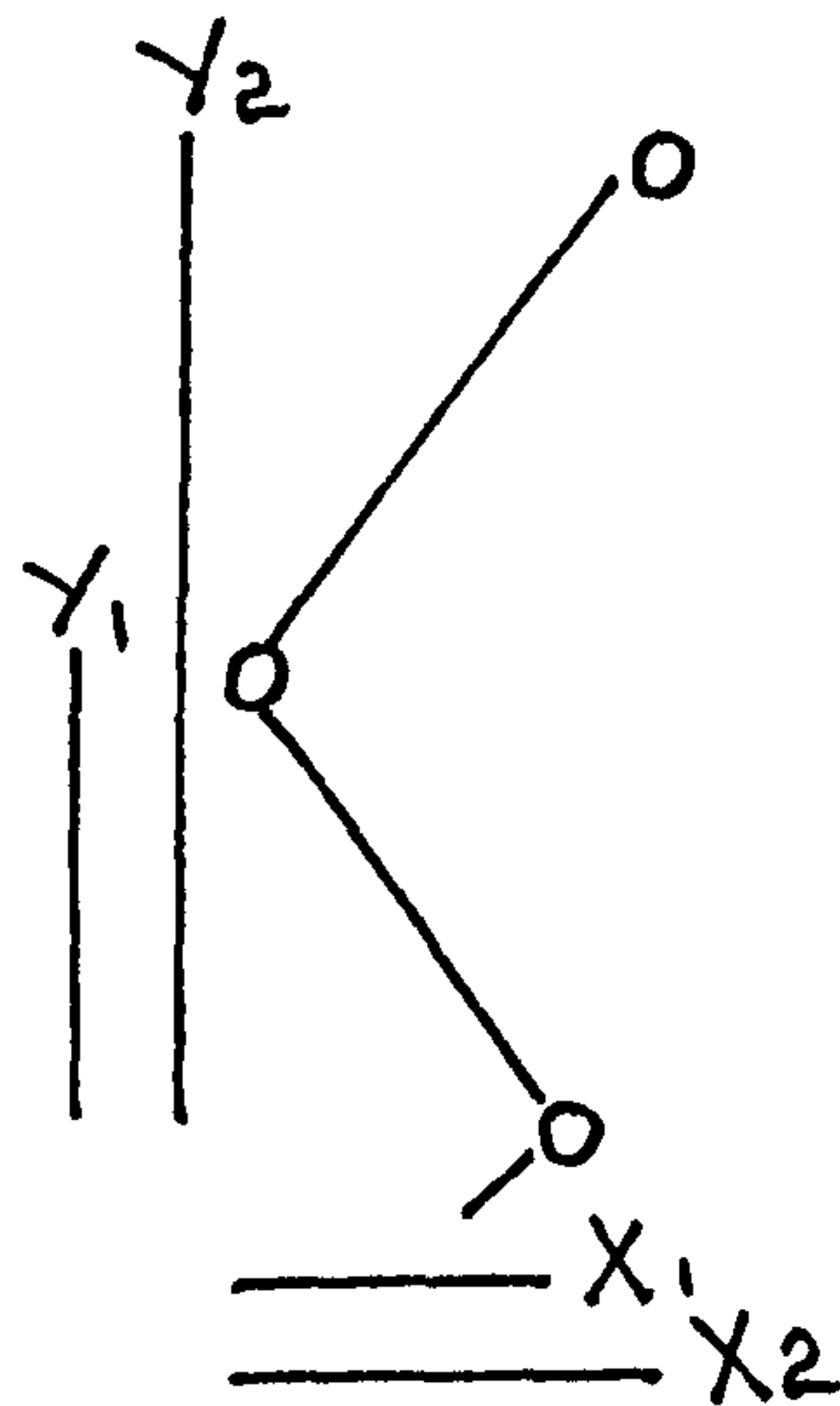

APPENDIX C

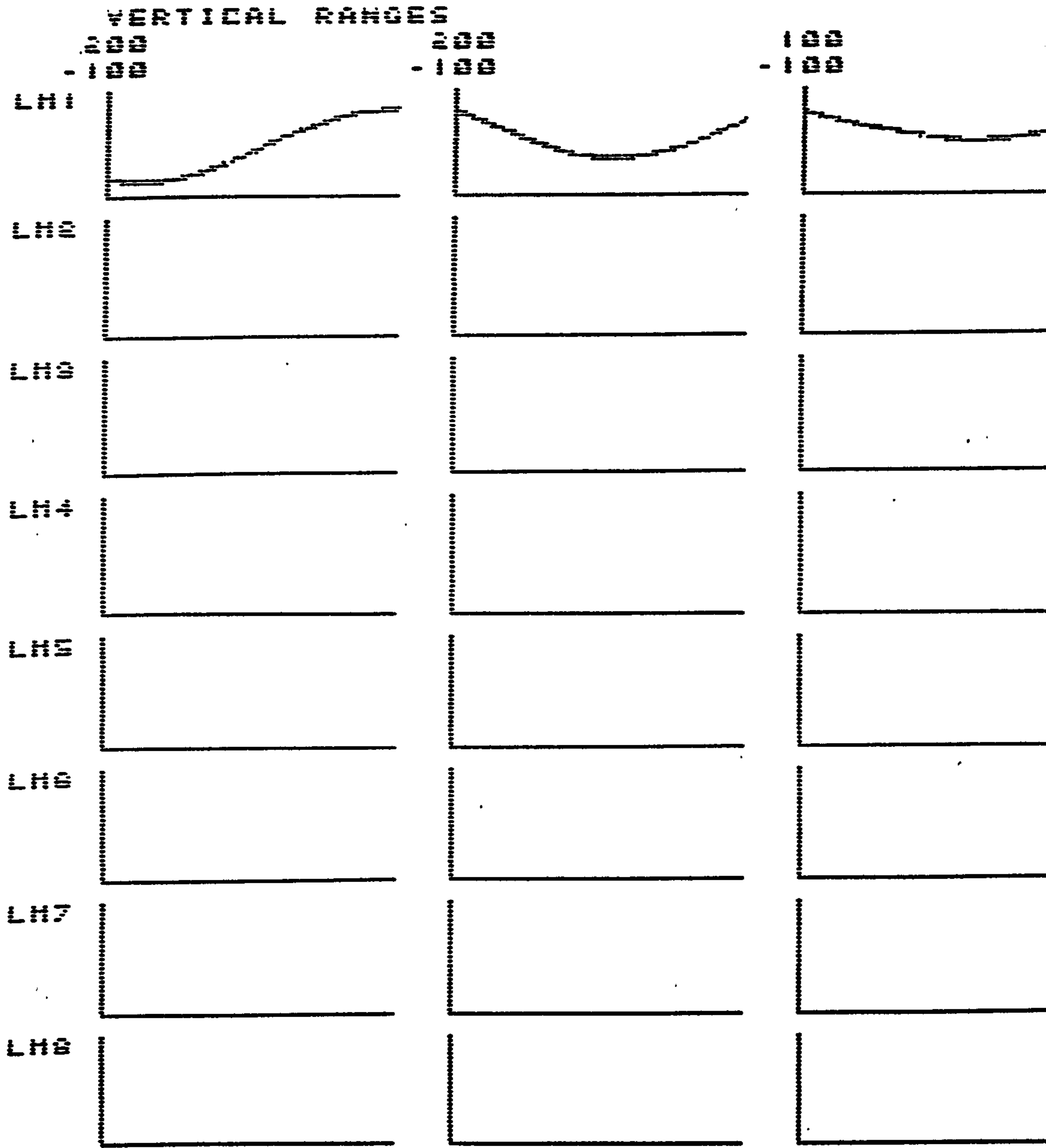

Fig. 1 X, Y and Z coordinates against time for landmark 1 moving at 16 rpm.

App C

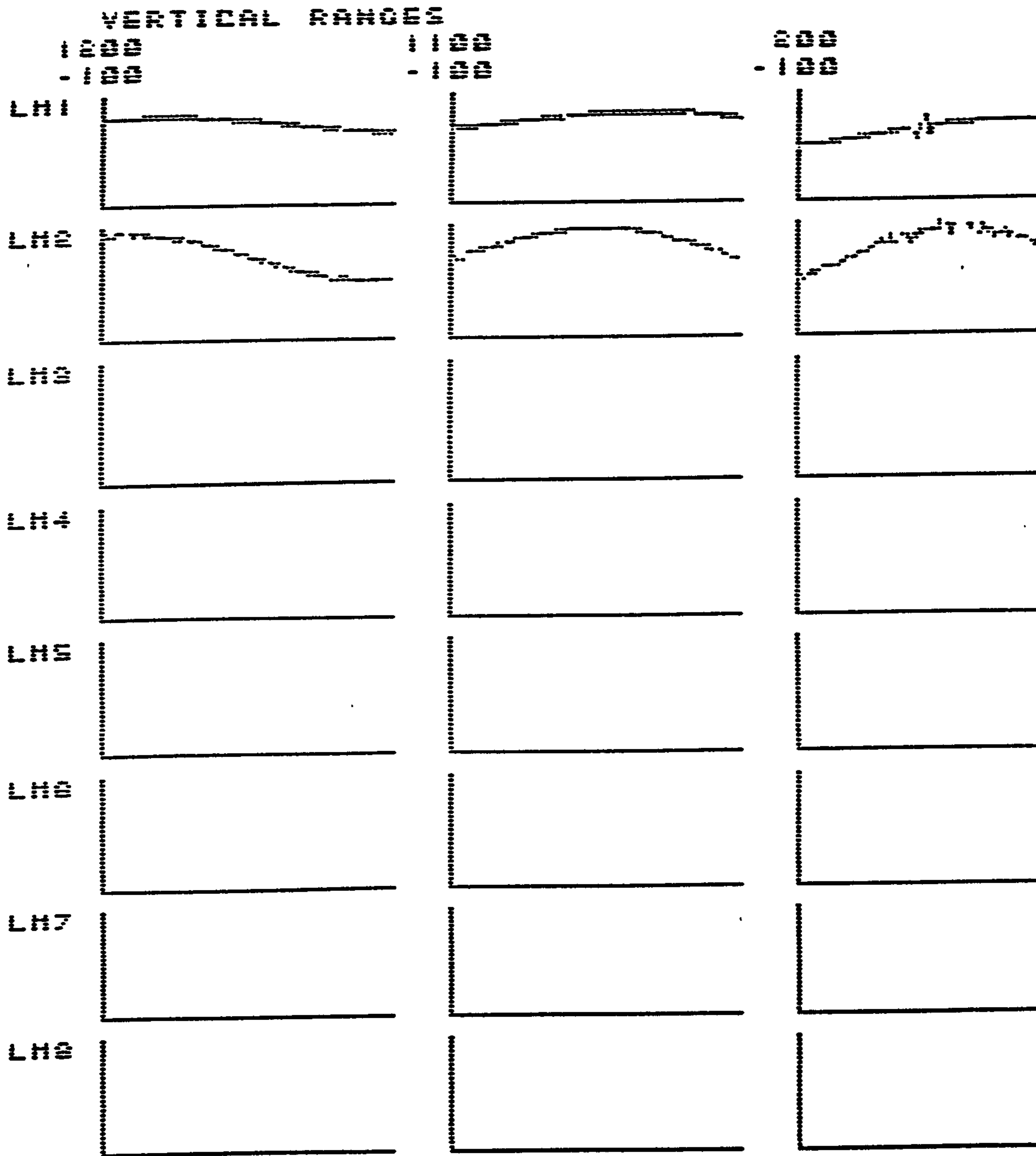

Fig 2 X, Y, and Z coordinates of landmarks 1 and 2  
moving at 16 rpm.

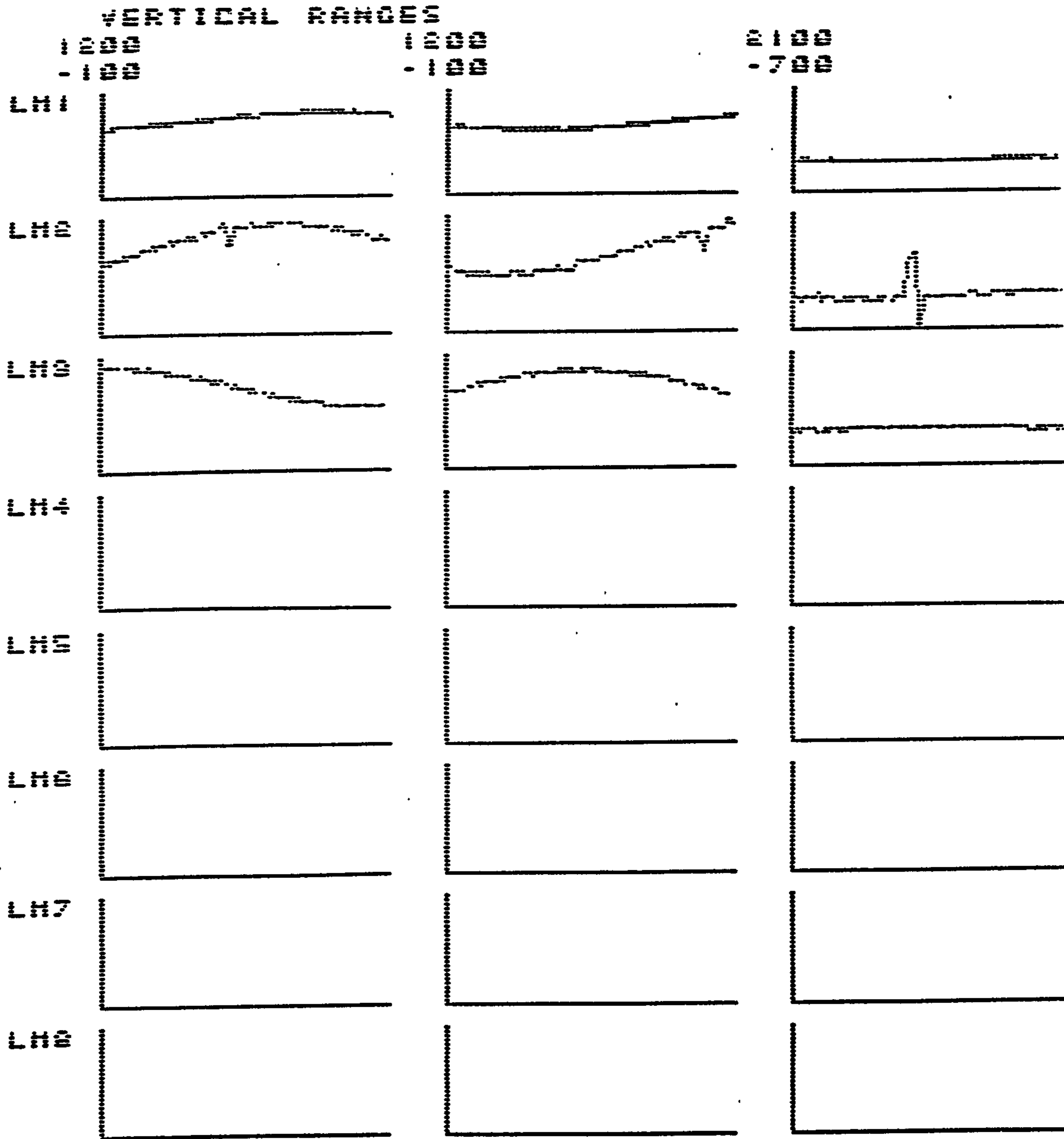

Fig. 3 X, Y, and Z coordinates against time for landmarks  
1-3, moving at 16 rpm.

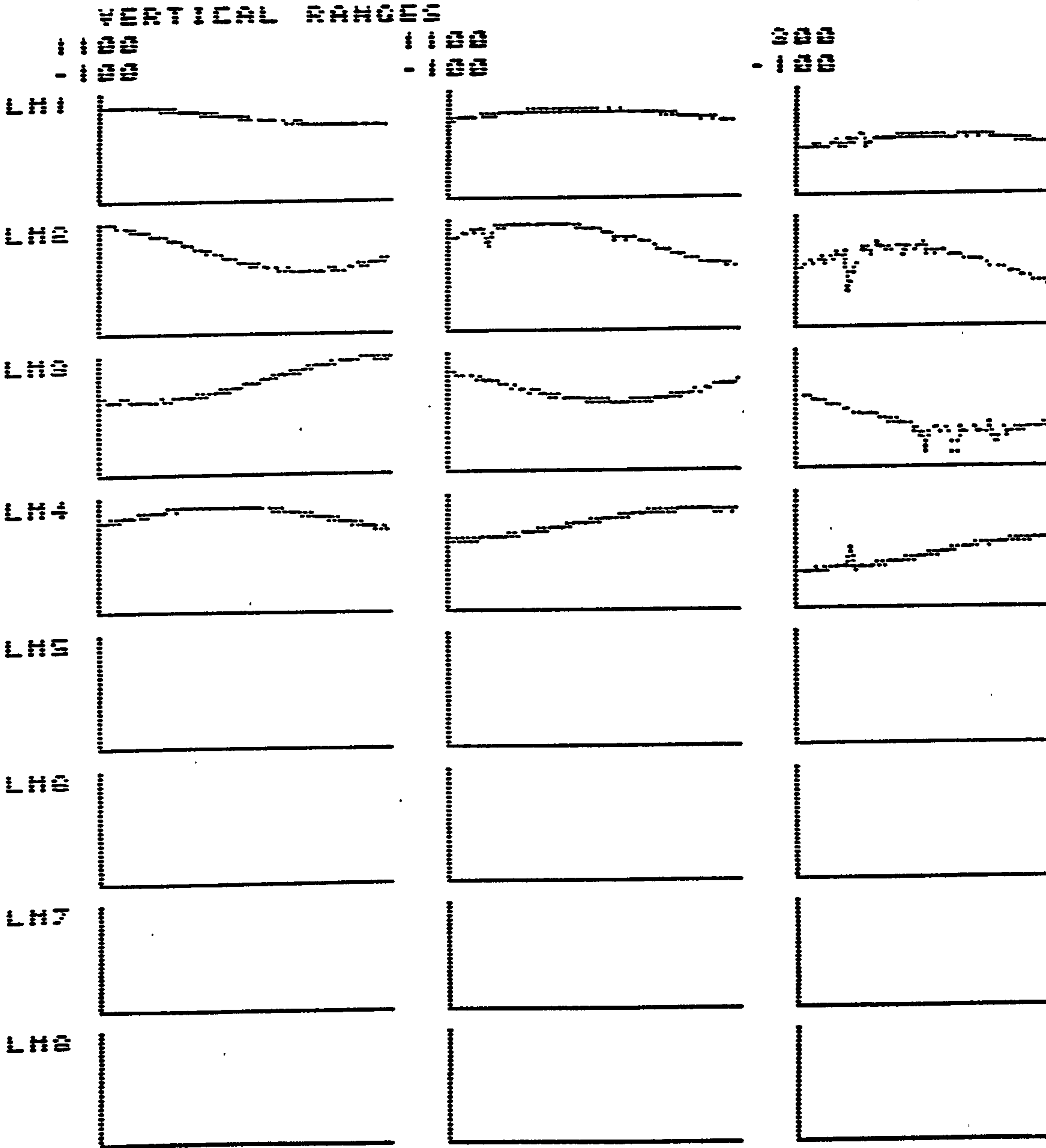

Fig. 4 X, Y, and Z coordinates against time for landmarks 1-4, moving at 16 rpm.

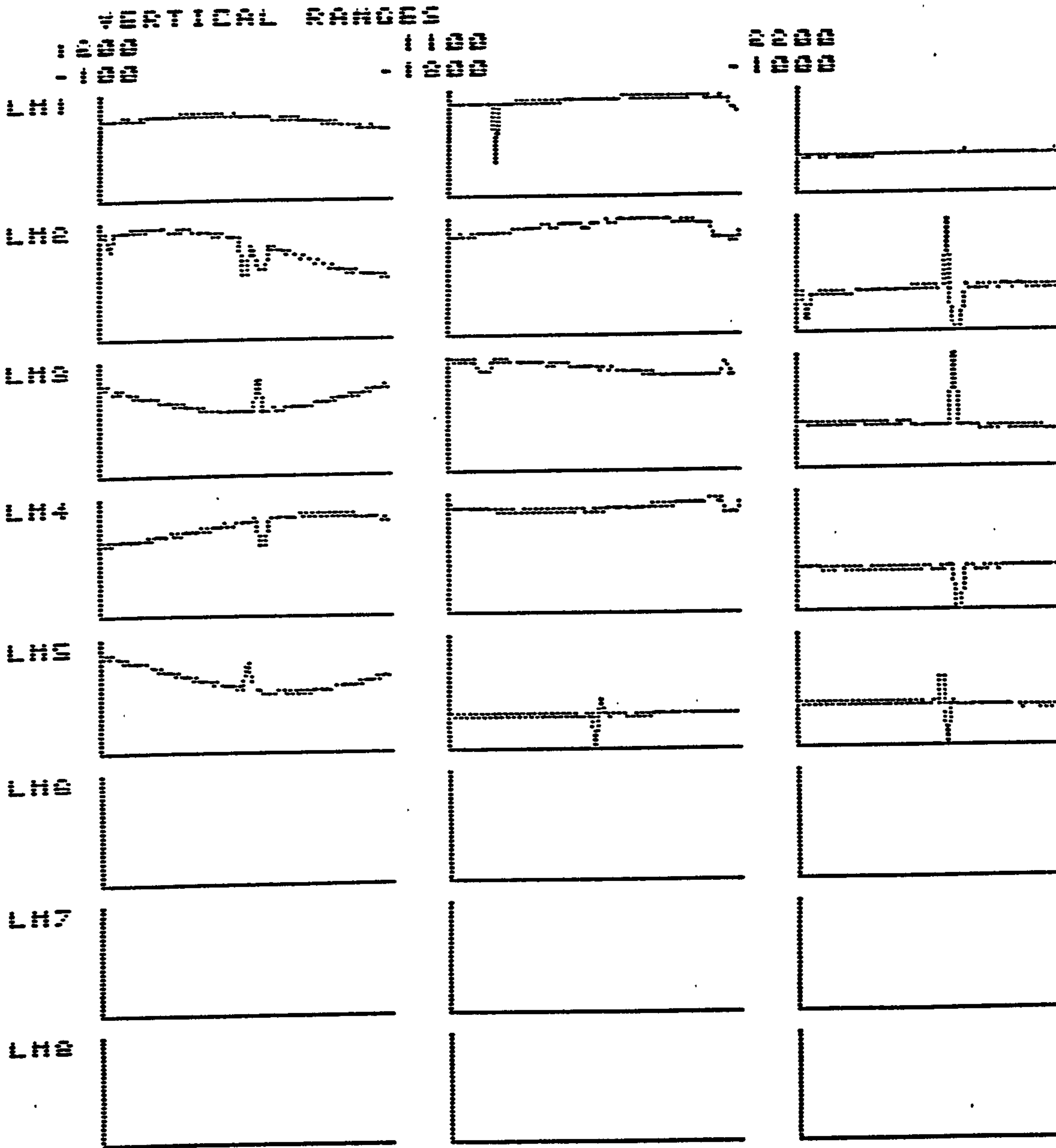

Fig. 5 X, Y, and Z coordinates against time for landmarks 1-5 moving at 16 rpm.



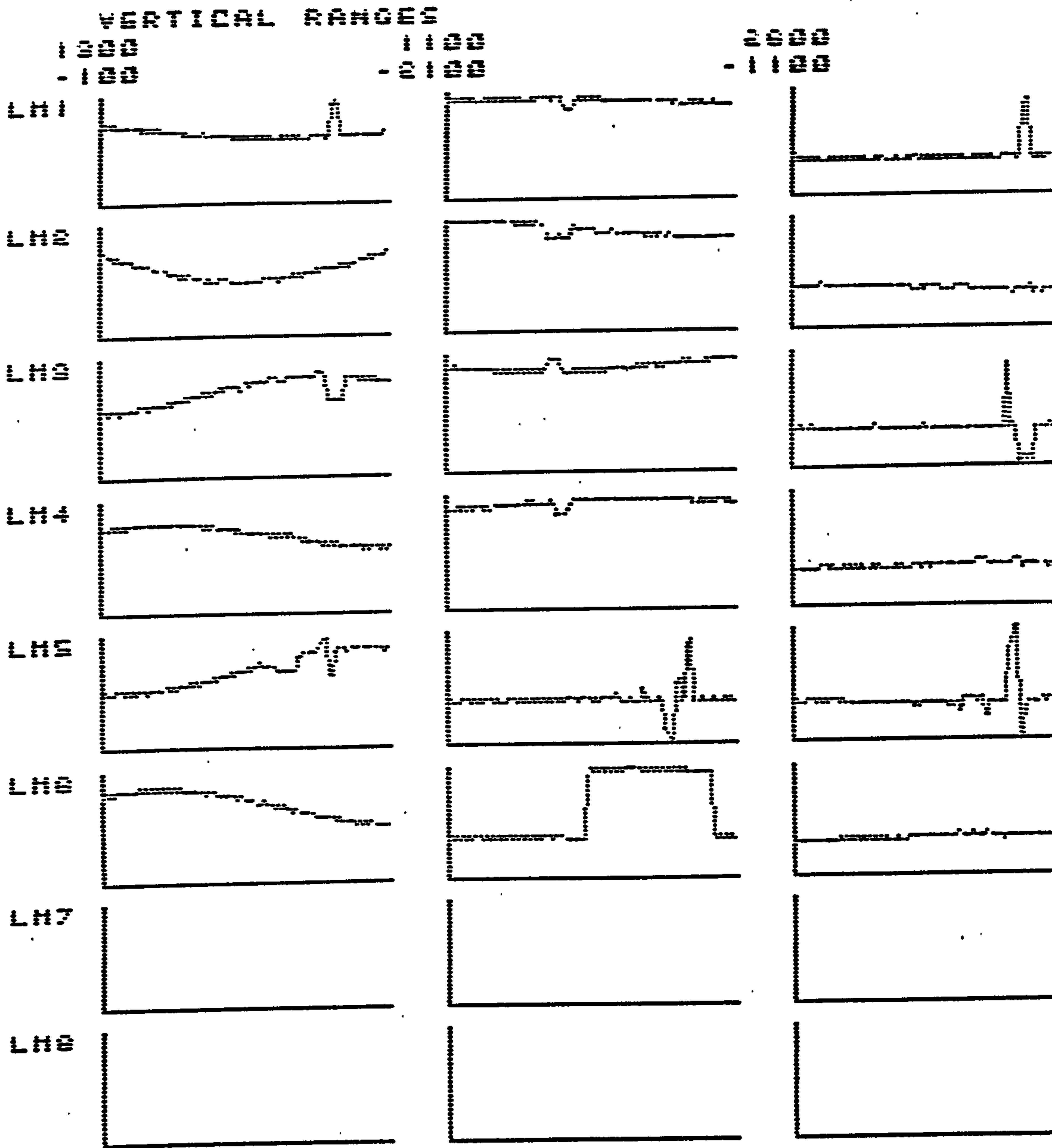

Fig. 6 X, Y, and Z coordinates against time for landmarks

1-6, moving at 16 rpm.

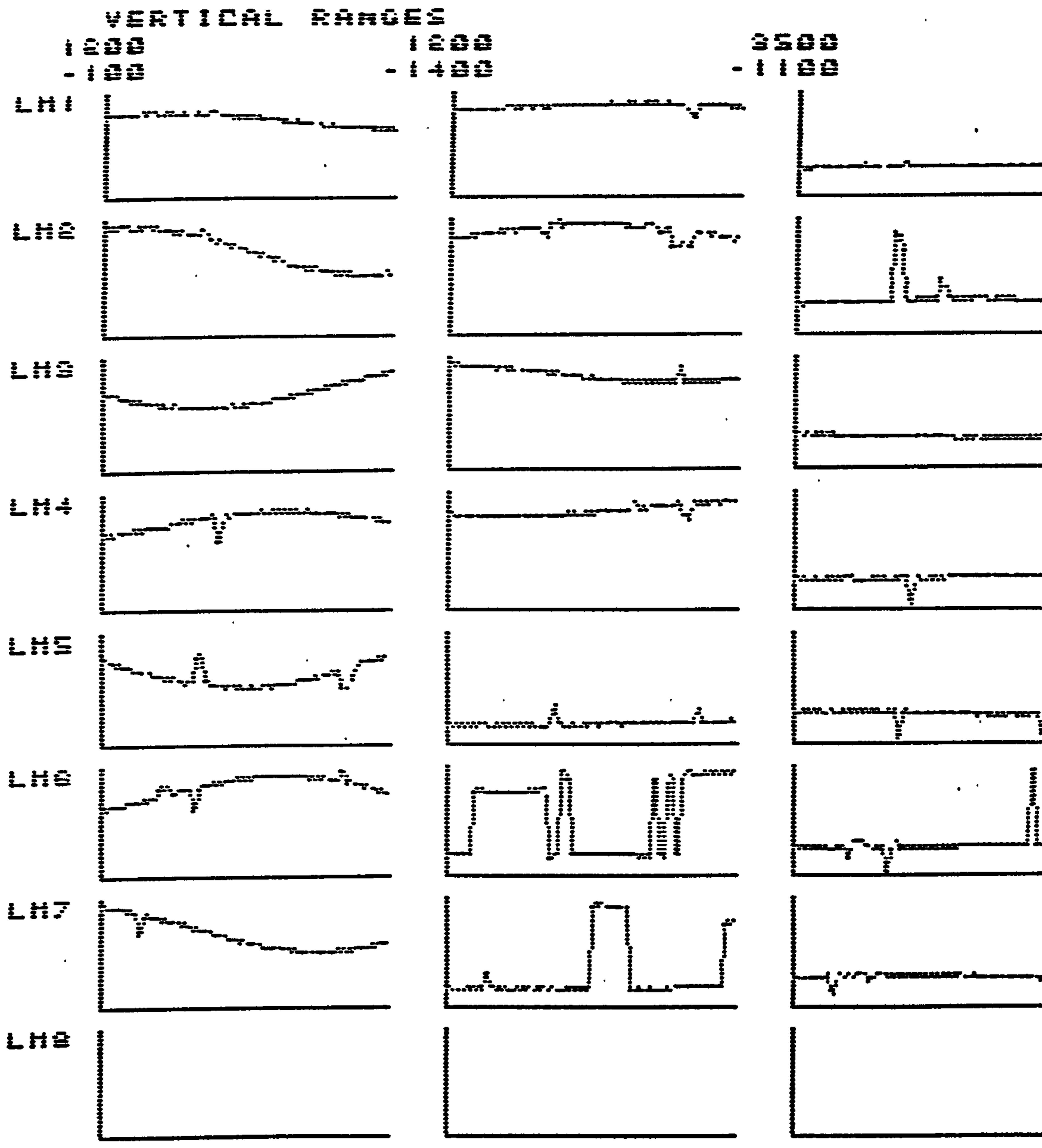

Fig. 7 X,Y and Z coordinates against time for landmarks

1-7, moving at 16 rpm.

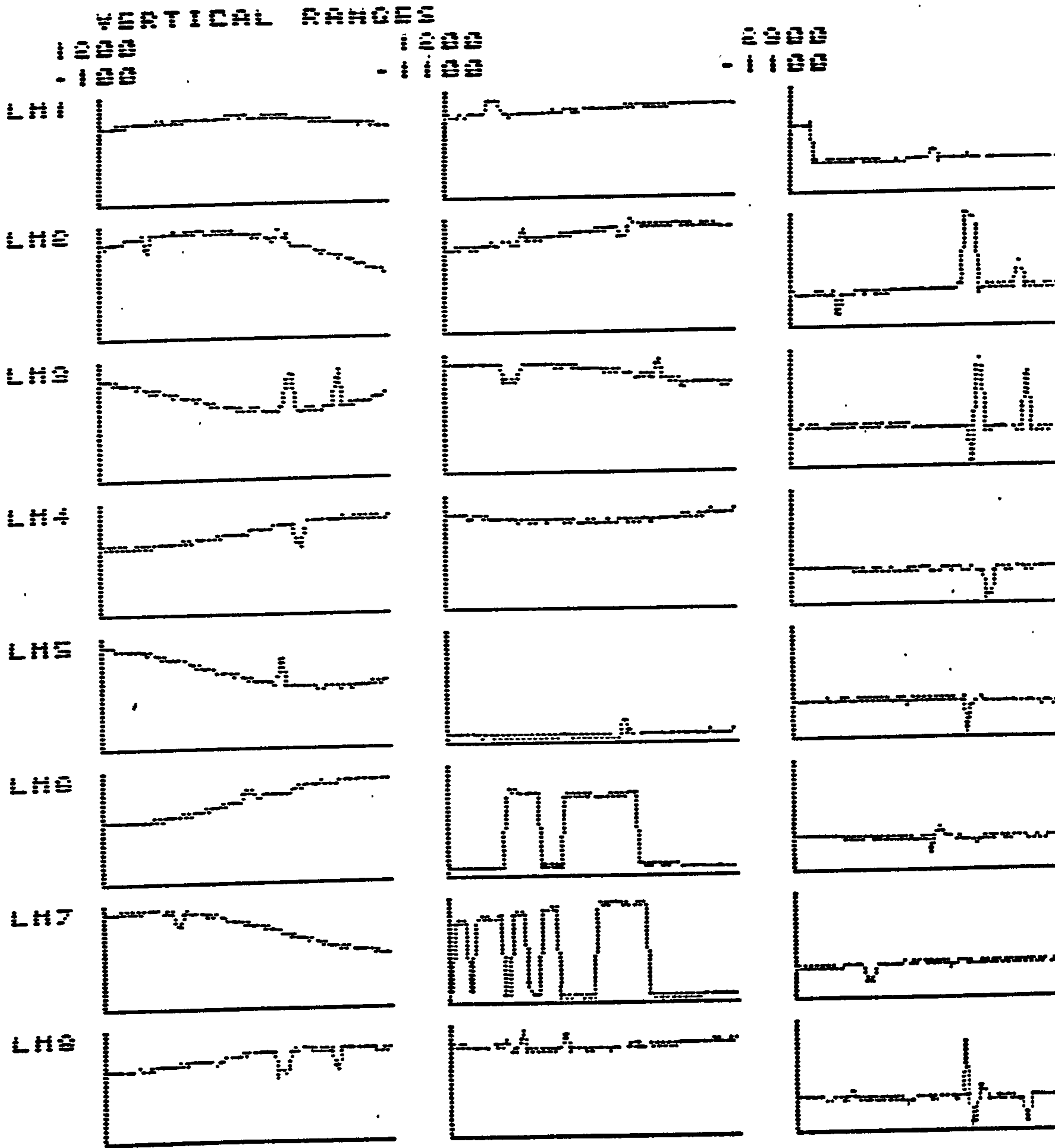

Fig 8 X, Y, and Z coordinates against time for landmarks  
1-8, moving at 16 rpm.

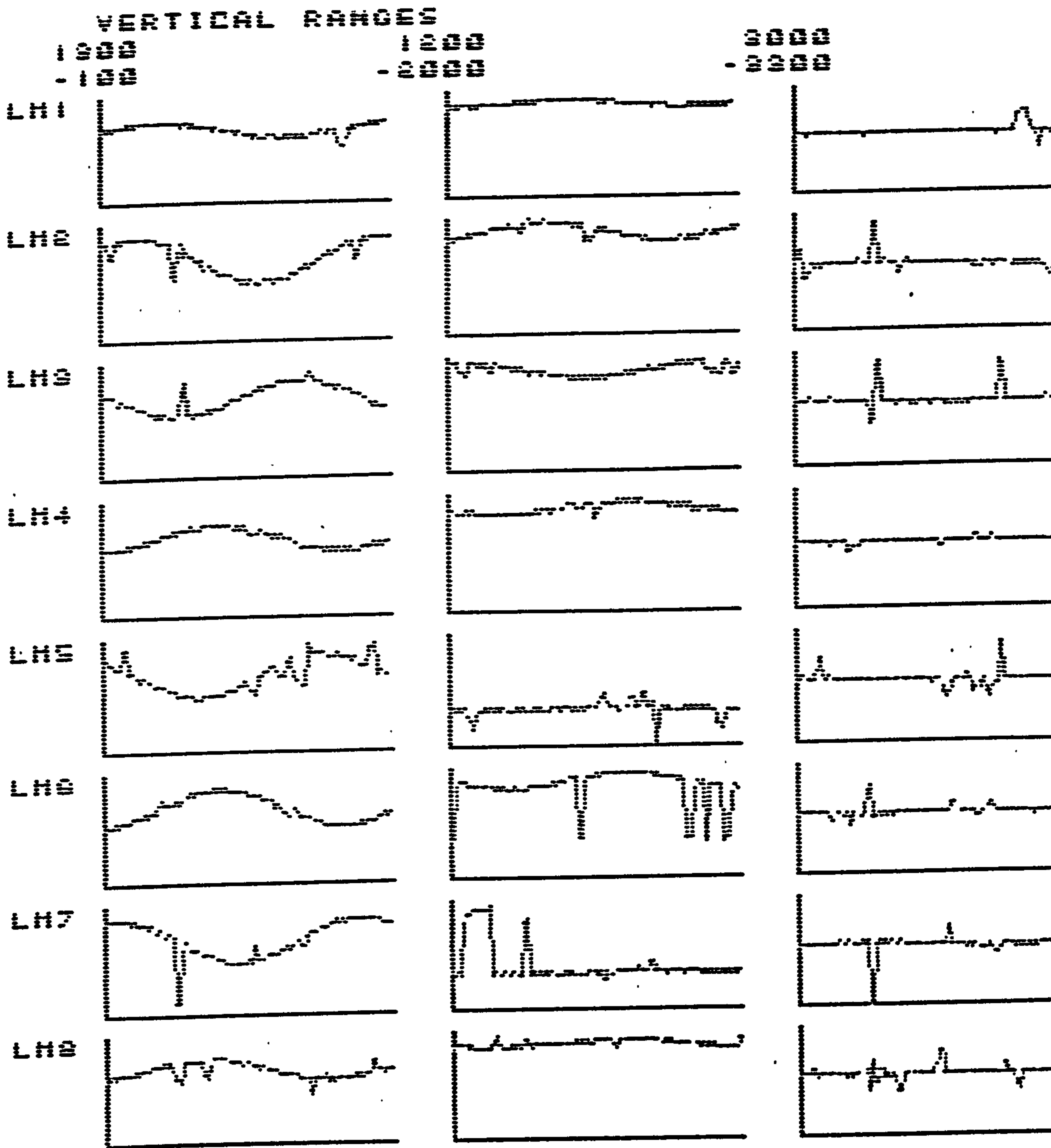

Fig. 9 X, Y, and Z coordinates against time for all eight landmarks moving at 33 rpm.

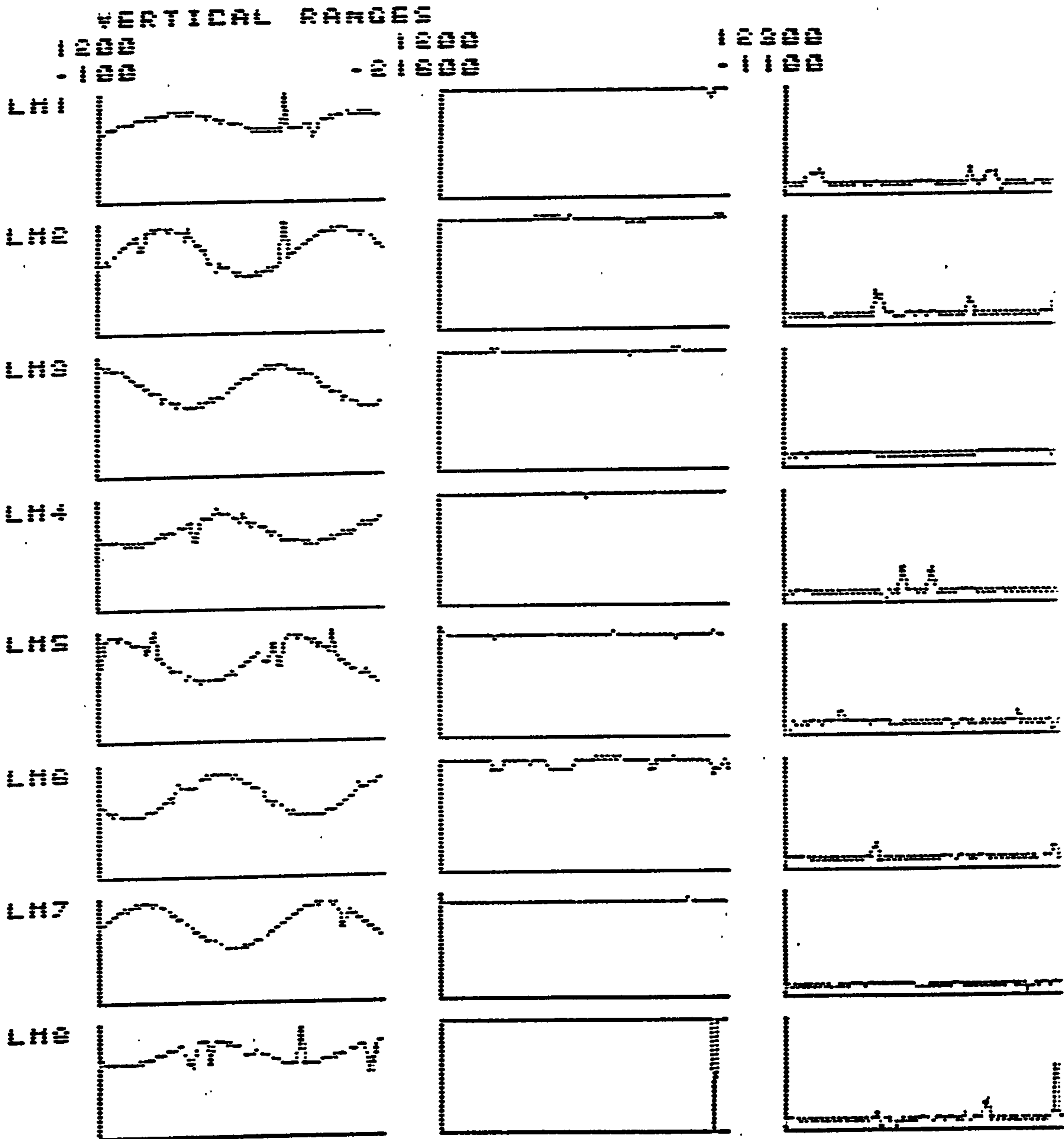

Fig. 10 X, Y, and Z coordinates against time for all eight landmarks moving at 45 rpm.

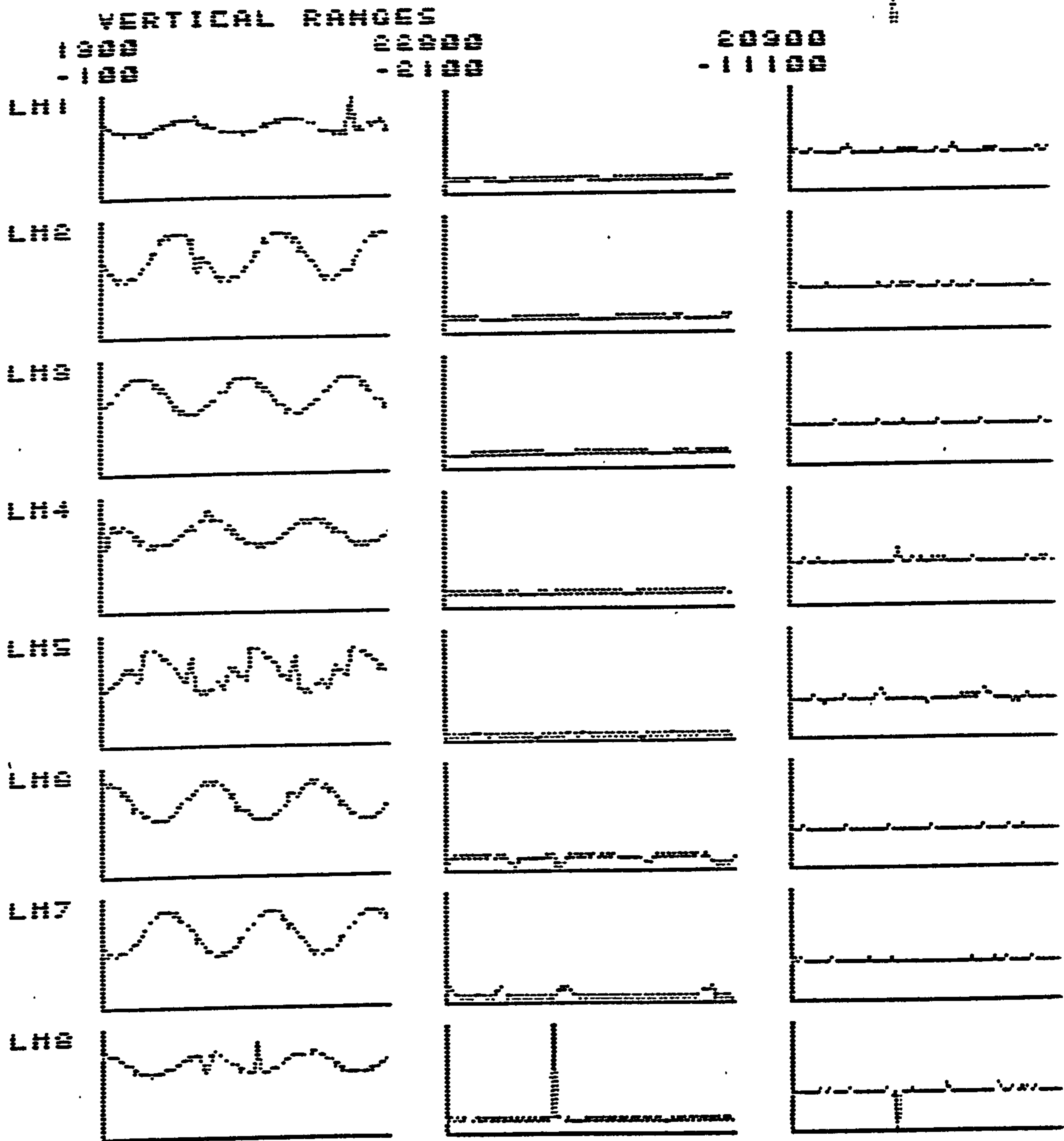

Fig. 11 X, Y, and Z coordinates against time for all eight landmarks moving at 78 rpm.

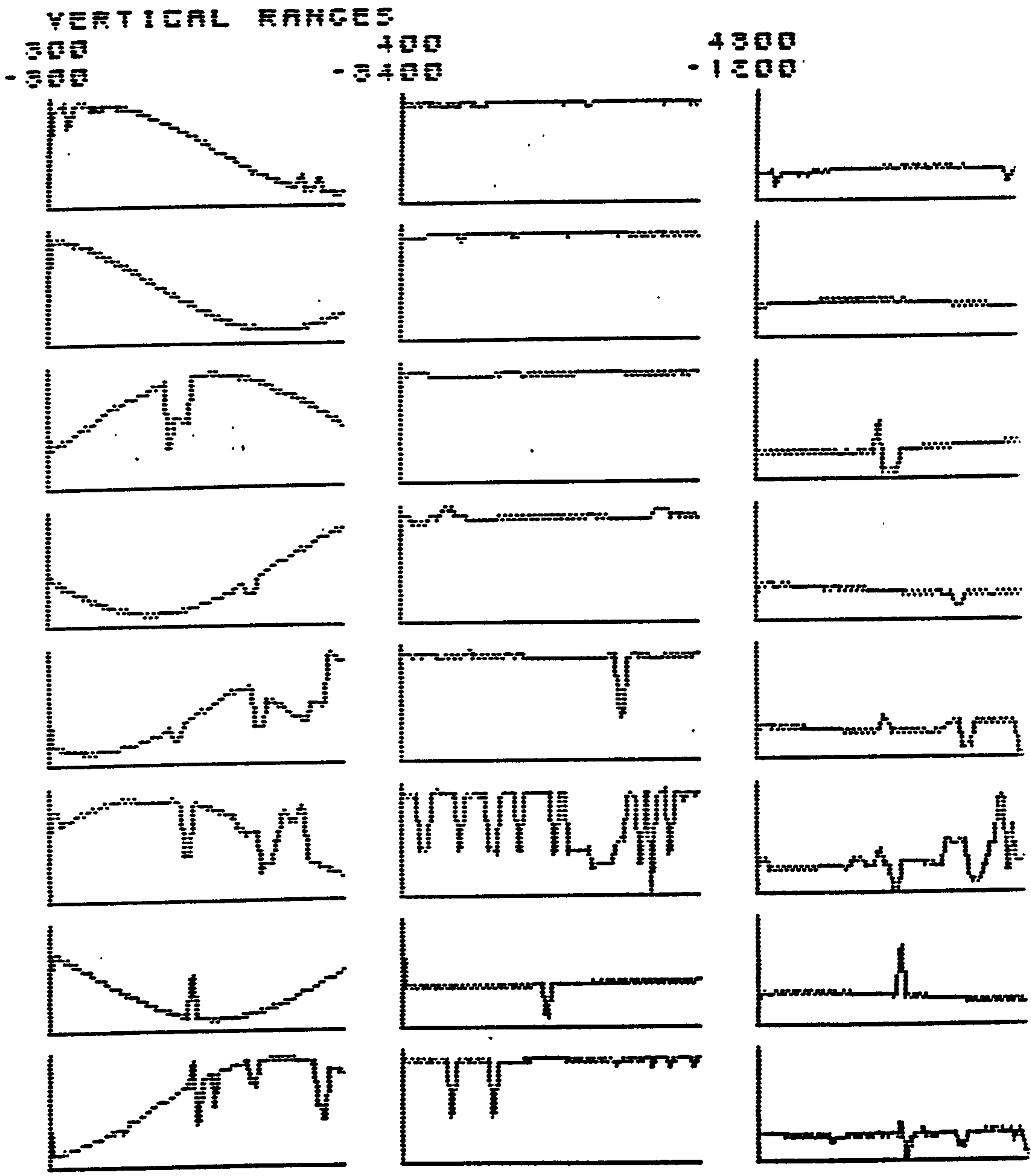

Fig. 12 X, Y and Z coordinates against time for clockwise order of landmarks as follows, 5,8,3,6,1,4,7,2.







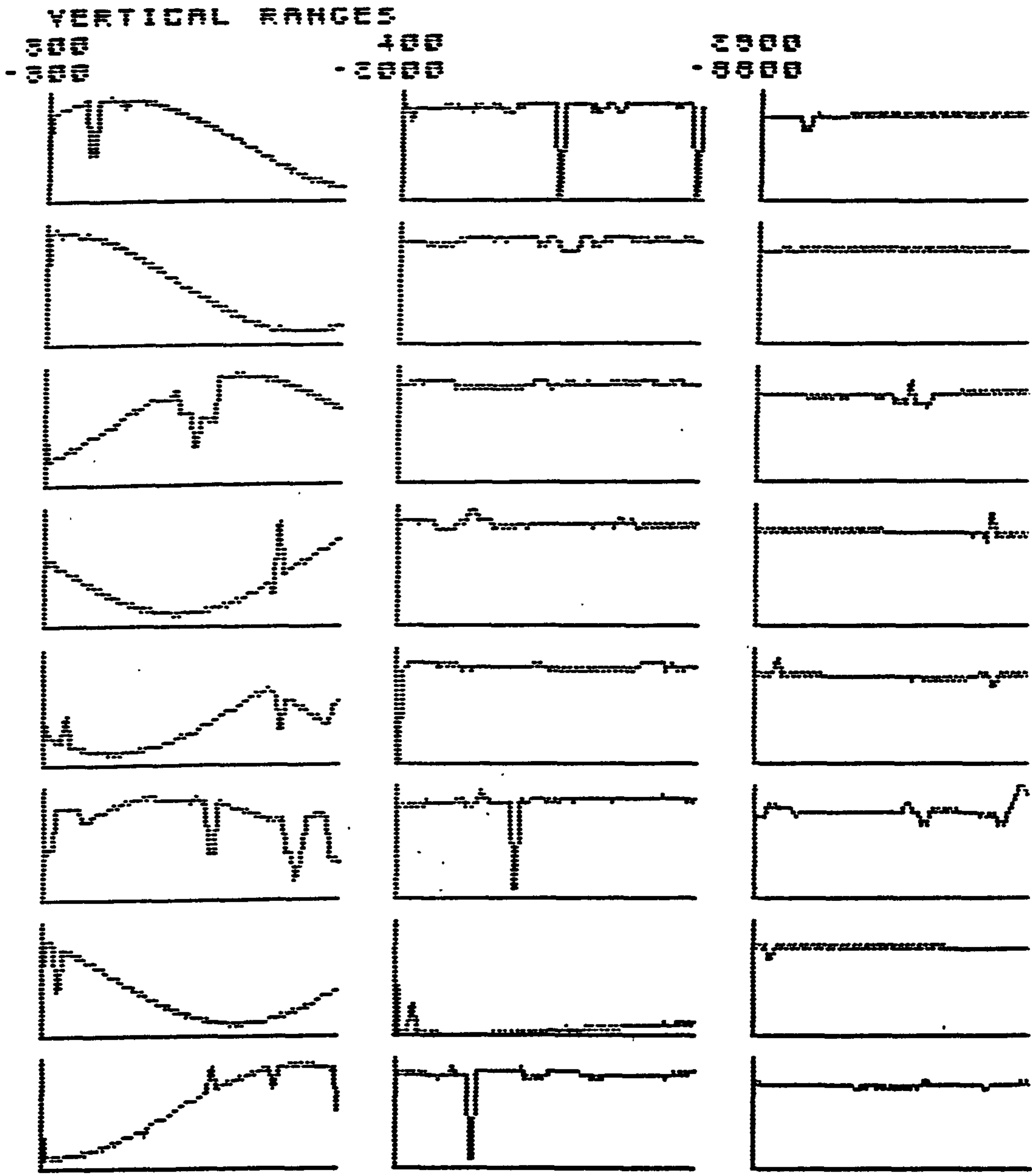

Fig. 15 X, Y, and Z coordinates against time for clockwise order of landmarks as follows, 5,8,2,6,4,3,7,1.

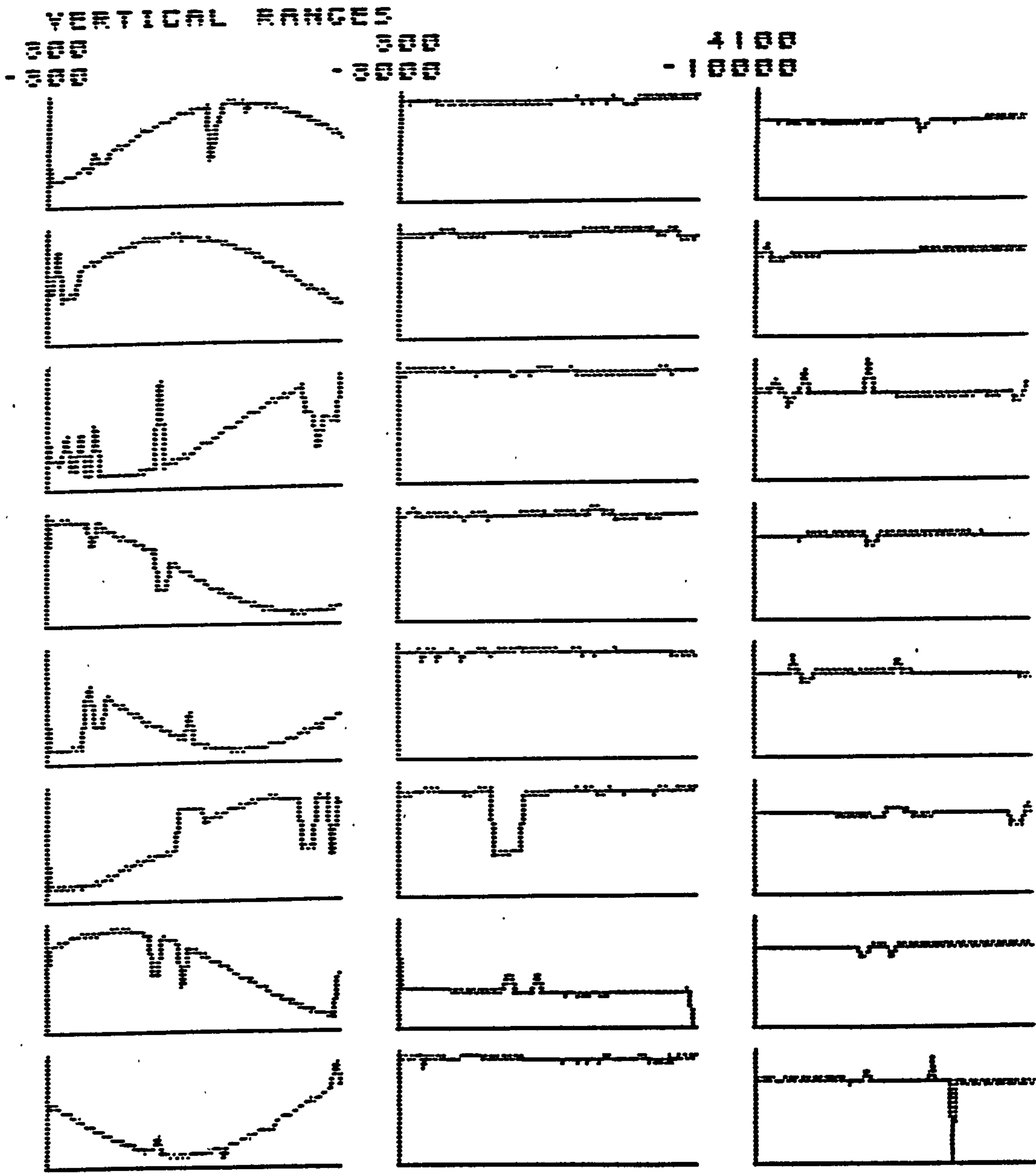

Fig. 16 X, Y, and Z coordinates against time for clockwise order of landmarks as follows, 4,8,2,6,5,3,7,1.

APPENDIX D

Find the sum of the squares of the observations in sample 1	$\Sigma x_1^2$
Find the sum of the squares of the observations in sample 2	$\Sigma x_2^2$
Find the square of the total of the observations in sample 1	$(\Sigma x_1)^2$
Find the square of the total of the observations in sample 2	$(\Sigma x_2)^2$
Divide the square of the total of the observations in sample 1	
by the number in sample 1	$\frac{(\Sigma x_1)^2}{n_1}$
Divide the square of the total of the observations in sample 2	
by the number in sample 2	$\frac{(\Sigma x_2)^2}{n_2}$

For each sample find the sum of the squares of the difference from their respective means:

$$\Sigma(x_1 - \bar{x}_1)^2 = \Sigma x_1^2 - \frac{(\Sigma x_1)^2}{n_1}; \Sigma(x_2 - \bar{x}_2)^2 = \Sigma x_2^2 - \frac{(\Sigma x_2)^2}{n_2}$$

The square of the standard deviation (variance) for the two samples combined is now as follows:

$$\frac{\Sigma(x_1 - \bar{x}_1)^2 + \Sigma(x_2 - \bar{x}_2)^2}{(n_1 - 1) + (n_2 - 1)} = SD^2$$

The divisors  $n_1 - 1$  and  $n_2 - 1$  represent degrees of freedom. They are referred to briefly above and in these circumstances are 1 less than the total in the sample.

The standard error of the difference between the means is

$$SE \text{ diff} = \sqrt{\frac{SD^2}{n_1} + \frac{SD^2}{n_2}}$$

When the difference between the means is divided by this standard error the result is  $t$ .

$$\text{Thus } t = \frac{\bar{x}_1 - \bar{x}_2}{\sqrt{\frac{SD^2}{n_1} + \frac{SD^2}{n_2}}}$$

Formulae used for calculation of Student's  $t$  values

NORMAL

Maximum x-direction velocities (cm/s).

MIN  
Maximum x-direction velocities (cm/s).

	FC						TIBIA					
	1	2	3	x	sd		1	2	3	x	sd	
Right	269	263	263	265	2.8	286	269	269	269	275	8.0	
Left	275	251	275	267	11.3	260	234	234	251	248	10.8	

TIBIA

FC

	FC						TIBIA					
	1	2	3	x	sd		1	2	3	x	sd	
Right	275	263	275	271	5.7	289	275	275	292	285	7.4	
Left	286	257	310	284	21.6	316	275	275	327	306	22.4	

Maximum y-direction velocities (cm/s).

Maximum y-direction velocities (cm/s).

Before heel-strike.

	FC						TIBIA					
	1	2	3	x	sd		1	2	3	x	sd	
Right	39	44	42	42	2.1							
Left	39	42	34	38	3.3							

FC

TIBIA

	FC						TIBIA					
	1	2	3	x	sd		1	2	3	x	sd	
Right	34	34	47	38	6.1							
Left	44	26	39	36	7.6							

After heel-strike

After heel-strike

	FC						TIBIA					
	1	2	3	x	sd		1	2	3	x	sd	
Right	21	13	14	16	3.6							
Left	16	21	13	17	3.3							

FC

TIBIA

	FC						TIBIA					
	1	2	3	x	sd		1	2	3	x	sd	
Right	29	29	34	31	2.3							
Left	23	13	29	22	6.6							

At toe-off

At toe-off

	FC						TIBIA					
	1	2	3	x	sd		1	2	3	x	sd	
Right	38	42	52	44	5.9	42	42	52	52	49	4.7	
Left	47	34	47	43	6.1	38	38	29	47	38	7.4	

FC

TIBIA

	FC						TIBIA					
	1	2	3	x	sd		1	2	3	x	sd	
Right	57	52	52	54	2.3	48	47	47	47	47	0.5	
Left	73	52	70	65	9.3	68	36	36	65	56	14.4	

Turning point values for selected parameters (raw data on which statistical analysis was performed).

#### REFERENCES:

AICROTH, P., FREEMAN, M.A.R., SMILLIE, I.S.,  
SOUTER, W.A. (1978). A knee function  
assessment chart. J Bone Jt Surg. 60-B (3)  
208-210.

ANDRIACCHI, T.P., HAMPTON, S.J., SCHULTZ,  
A.B., GALANTE, J.O. (1979). The  
three-dimensional coordinate data processing  
in human motion analysis. J Biomech.  
101(14), 279-283.

ANDRIACCHI, T.P., GALANTE, J.O., FERMIER,  
R.W. (1979). The influence of TKR design on  
walking and stair climbing. J Bone Jt Surg.  
64-A (9). 1328-1336.

ARNELL, P., JOHNSON, F. and OBORNE, J.  
(1982). The use of angle diagrams for  
quantitative evaluation of joint function  
during locomotion. Internal Publication  
Department of Orthopaedic Surgery, University  
of Manchester, U.K.

BRANTIGAN, D.C., VOSHELL, A.F. (1941). The mechanics of the ligaments and menisci of the knee joint. J Bone Jt Surg. 23 (1). 44.

BRESLER, B., FRANKEL, J.P. (1950). Transactions of the American Soc. Mech. Eng. 72, 77.

CAPPOZZO, A. (1883). Considerations on clinical gait evaluation. J Biomech. 16(4) 302.

CARLSOO, S. (1972). How Man Moves Kinesiological Studies and Methods. Heinemann, London.

CHAO, E.Y. (1980). Justification of triaxial soniometry for the measurement of joint rotation. J Biomech. 13(12) 989-1006.

CHAO, E.Y., LAUGHMAN, R.K., STAUFFER, R.N. (1980). Biomechanical gait evaluation of pre and post-operative total knee replacement patients. Arch. Orthop. Traumatic Surg. 97(4) 309-317.



ELFTMAN, H. (1938). The rotation of the body in walking. *Arbeitsphysiol.* 10:477-484.

ELLIS, M.I., SEEDHOM, B.B. and WRIGHT, V. (1984). Forces in the knee joint whilst rising from a seated position. *J Biomed. Engng.* No. 6 April ed.

FAIRBANK, T.J. (1948). Knee joint changes after menisectomy. *J Bone Jt. Surg* 30-B 664-670.

FETTO, J.F., MARSHALL, J.L. (1981). Natural history and diagnosis of anterior cruciate Ligament insufficiency. *Clin. Orthop. Rel. Res.* 147, 19-38.

FICK, R., FISHER, G. (1911) *Mechanics of the knee.* Handbuch der Anatomie und Mechanik der Gelenke unter Berücksichtigung der bewegenden Muskeln. 3rd volume Jena 1904-1911.

FRANKEL, V.H., BURSTEIN, A.M., BROOKS, B.D. (1971). Biomechanics of the internal derangement of the knee. *J Bone Jt Surg.*

53-A (5). 945.

FUKUBAYASHI, T., TORZILLI, P.A., SHERMAN, M.F., WARREN, R.F. (1982). An in vitro biomechanical evaluation of a-P motion of the knee. J Bone Jt Surg. 64-A (2) 258-264.

GODFREY, C.M., FALCONER, K.A. (1980). Reliability of the CARS-UBC electrogoniometer. Proc. Spec. Conf. of the CSB Human Locomotion October.

GRAY, H. (1901). Gray's Anatomy. XV Edition. Bounty New York.

GRIEVE, D.W. (1963). Gait patterns and speed of walking. Biomedical Engng. March.

GRIEVE, D.W. (1969). Device called the Polson for measurement of orientation of body relative to a fixed external axis. J Physiology 201 706P.

GRIEVE, D.W. (1969). The assessment of gait. Physiotherapy, 55, 11 452-460.

HANNAH, R.E., McBRAW, R.W. (1980).  
Assessment of the total knee arthroplasty: an  
attempt to correlate passive and dynamic  
variables. Proc. Spec. Conf. of the CSE  
Human Locomotion October.

HARRINGTON, I.J. (1976). A bioengineering  
analysis of force actions at the knee in  
normal and pathological gait. Biomed.  
Engng. May.

HERSHLER, C. and MILNER, M. (1980).  
Angle-angle diagrams in the assessment of  
locomotion. Am. J. Phys. Med., 59,  
109-125.

HOPPENFELD, S. (1976). Physical examination  
of the spine and extremities. Publishers  
Appleton.

HUGHSTON, J.C., ANDREWS, J.R., CROSS, M.J.,  
MOSCHI, A. (1976). Classification of knee  
ligament instabilities. Part I. J. Bone  
Jt. Surg. 58-A (2) 159-179.

HUGHSTON, J.C., BARETT, G.R. (1983). Acute

anteromedial rotatory instability. J. Bone  
Jt. Surg. 65-A (2) 145-153.

INMAN, V.T., RALESTON, H.J., TODD, F. (1981).  
Human Walking. Williams and Wilkins  
Baltimore.

JOHNSON, F., WAUGH, W. (1979). Methods for  
routine clinical assessment of knee joint  
forces. Med. Biol. Engng. Comput. 17  
145-154.

JOHNSON, F., SCARROW, P., WAUGH, W. (1981).  
Assessment of loads in the knee joint. Med.  
Biol. Engng. Comput. 19, 237-243.

JOHNSON, F., OBORNE, J., ALLEN, M., WAUGH, W.  
(1982). Continuous assessment of knee  
function and patient mobility. J Biomed.  
Engng. 4 2-8.

JOSEPH, J. (1960). Man's posture :  
Electromyographic Studies. Charles C.  
Thomas, Springfield, Illinois, 1960.

KAPANDJI, I. A. (1970). Kinesiology and

Applied Anatomy, The Science of human  
Movement'. XI Edition. Lea and Febiger  
Philadelphia.

KARPOVICH, P.V., HERDEN, E. L., ASA, M.M.  
(1960). Electrogoniometric study of joints.  
U.S. Armed Forces Med. J. 11, 424-50.

KASVAND, T., MILNER, M. (1972). Pattern  
recognition applied to measurement of human  
limb position during movement. J Cybernetics  
2, 66-78.

KASVAND, T., MILNER, M., QUANBURY, A.O.,  
WINTER, D. (1976). Computers and the  
kinesiology of gait. Comput. Biol. Med.  
6, 111-120.

KEMP, B., FRANZEN, J.M., BURLIMA, O.J.S.,  
ROOS, R.A.C. (1982). Quantification of  
random body movements by a Doppler radar  
device. Med. Biol. Engng. Comput. 20,  
539-544.

KETTLEKAMP, D.B., CHAO, E.Y. (1972). A  
method for quantitative analysis of medial

and lateral compressive forces at the knee during standing. Clin. Orthop. Rel. Res. 83, March-April.

KISTLER INSTRUMENTS AG. (1977). Operating and service instructions for the multicomponent measuring platform for biomechanics and industry, Type 9261A.

LAFORTUNE, M.A., CAVANAGH, P.R., KALENAK, A., SKINNER, S.M., SOMMER, H.J. (1983). The measurement of normal knee joint motion during walking using intracortical pins. Conf. Biomechanical Measurement in Orthopaedic Practise. April 1983, Oxford Orthop. Enns. Centre.

LAYCOCK, G.A. (1976) An investigation to determine changes in female gait patterns due to the wearing of raised heel shoes. B.Sc. Special Topic Study. Loughborough University.

LEVY, I.M., TORZILLI, P.A., WARREN, R.F. (1982). The effect of medial meniscectomy on anterior-posterior motion of the knee. J

Bone Jt Surg. 66-A (6), 883-888.

LIPKE, J.M., JANECKI, C.J., NELSON, C.L.,  
McLEOD, F., THOMPSON, C., THOMPSON, J.,  
HAYNES, D.W. (1981). The role of  
incompetance of the anterior cruciate and  
Lateral Ligaments in anterior-lateral and  
antero-medial instability. J Bone Jt Surg.  
63-A (6), 954.

LIPPERT, F.G., VERESS, S.A., TIWARI, R.S.,  
HARRINGTON, R.M. (1978). The measurement of  
total joint loosening by x-ray  
photosrammetry. SPIE Vol. 166 NATO Symposium  
on Applications of Human Biostereometrics.

MACELLARI, V. (1983). CoSTEL: a computer  
peripheral remote sensing devise for 3D  
monitoring of human locomotion. Med. Biol.  
Engng. Comput. 23(3), 311-319.

MAQUET, P.G., VAN DE BERG, A.J., SIMONET,  
J.C. (1975). Femorotibial weight-bearing  
areas. J Bone Jt Surg 57-A (6), 766.

MILNER, M., BRENNAN, P.K., WILBERFORCE,

C.B.A. (1973). Stroboscopic polaroid photography in clinical studies of human locomotion. S.A. Med. J. 47.

MITCHELSON, D. L. (1975). Recording of Movement without photography. In Techniques for the Analysis of Human Movement, Grieve, Miller, Mitchelson, Paul and Smith, Lippincott Books, London, 33-65.

MITCHELSON, D. L. (1977). Clinical assessment of gait using the Polarised Light Goniometer. Orthop. Engng. Conf. Oxford (B.E.S.) London 1977.

MORRISON, J.B. (1968). Bioengineering analysis of force actions transmitted by the knee joint. Biomed. Engng. April 164-170.

MORRISON, J.B. (1969) Function of the knee joint in various activities. Biomed. Engng. December 573-580.

MURRAY, P., DROUGHT, A.B., KORY, R.C. (1964). Walking patterns of normal men. J Bone Jt Surg. 46-A. 335-340.



MURRAY, P. (1937). Gait as a total pattern of movement. Am. J. Phys. Med. 46(1) 290-333.

NISSAN, M. (1980). Review of some basic assumptions in knee biomechanics. J Biomech. 13, 375-381.

PAUL, J.J. (1974). Force actions transmitted in the knees of normal subjects and by prosthetic joint replacements. Inst. Mech. Engrs. 126-131

PEIZER, E., WRIGHT, D.W. (1971). Human Locomotion. In Human Locomotor Engineering. Conf. Proc. I. Mech. Engrs. 1967. 196-214.

PERRY, J., ANTONELLI, D., FORD, W. (1975) Analysis of knee joint forces during flexed knee stance. J Bone Jt Surg. 57-A. 961-967.

PIZZIALLI, R. SEERING, W.P., NAGEL, D.A., SCHURMAN, D.J. (1980). The function of the primary ligaments of the knee in

anterior-posterior and medio-lateral motions.  
J Biomech. 13, 777-784.

PYNSENT, P. B., FAIRBANK, J. C. T., CLACK,  
F. J., PHILLIPS, H. (1983). Computer  
recording of anatomical points in three  
dimensional space. J. Biomed. Eng. Vol 5  
April, 137-140.

RASCH, P.J. and BURKE, R.K. (1978). XI  
Edition. Lea and Febiger Philadelphia.

REED, D.J., and REYNOLDS, P.J. (1969). A  
joint angle detector. J. Applied Physiology  
Vol. 27, No. 5 November.

SEEDHOM, B.B., DOWSON, D., WRIGHT, V.  
(1973). Wear of solid phase formed high  
density polyethylene in relation to the life  
of artificial hips and knees. Wear 24,  
35-51.

SEERING, W.P., PIZIALLI, R., NAGEL, D.A.,  
SCHURMAN, D.J. (1980). The functions of the  
primary ligaments of the knee in varus-valgus  
and axial rotation. J Biomech. 13, 785-794.

SHOEMAKER, S.C. (1982). In vivo rotator, knee stability. J. Bone Jt. Surg. 64-A (2) 209-214.

SHROFF, S., MILNER, M., KITAI, R. (1976). Ultrasonic tracking of body motions. Digest 11th Int. Conf. on Med. Biol. Engng. Ottawa, Canada 84-85.

STAUFFER, R.N. (1977). Biomechanical gait analysis of the diseased knee joint. Clinical Orthop. Rel. Res. 126, July-August.

STEINDLER, A. (1955). Kinesiology of the human. Springfield III. Charles C. Thomas Pub.

SWANSON, S. A. V. (1980). Biomechanics. in Arthritis of the Knee: Clinical features and surgical management. Ed Freeman M.A.R. Springer-Verlag.

TEW, M., WAUGH, W. (1982). Estimating the survival time of knee replacements. J. Bone Jt Surg. 64-B (5). 579-582.

TORZILLI, P.A., GREENBERG, R.L., INSALL, J.  
(1981). An in vivo biomechanical evaluation  
of a-p motion of the knee. Roentgenographic  
measurement technique, stress machine and  
stable population. J. bone Jt. Surg. 63-A  
(6) 960-968.

TOWNSEND, M. A., IZAK, M., JACKSON, R.W.  
(1977) Total motion knee goniometry. J  
Biomech. 10, 183-192.

VAN DIJK, R., HUIJK, R., SEVIK, G. (1979).  
Roentgen stereophotogrammetric methods for  
the evaluation of the three dimensional  
kinematic behaviour and cruciate ligament  
length patterns of the human knee joint. J  
Biomech. 12 (9) 727-732.

WALL, P.D. (1979). On the relation of  
injury to pain. Pain 6:253-264.

WANG, C.J., WALKER, P.S. (1974). Rotatory  
Laxity of the human knee joint. J Bone Jt  
Surg. 56-A (1). 161-170.

WAUGH, W. (1979). Designing records for

evaluating knee replacements. Clinical  
examination. Harlow Wood Internal  
Publication. No. 3

WAUGH, W., TEW, M., JOHNSON, F. (1981).  
Methods of evaluating results of operations  
for chronic arthritis of the knee. J Royal  
Soc. Med. 74, May 343-347.

WINTER, D.A., GREENLAW, R.K., HOBSON, D.A.  
(1972). TV-computer analysis of kinematics  
of gait. Comp. Biomed. Res. 5, 498-504.

---

WINTER 1979 . Biomechanics of Human Movement.  
Pub. John Wiley and Sons.

WINTER 1975

WOLTRING, H.J. (1974). New possibilities  
for human locomotion studies by real-time  
light spot position measurements.  
Biotelemetry 1, 132-146.

WOLTRING, H.J., MARSOLAIS, E.B. (1980).  
Optoelectronic (Selspot) gait measurement in  
two and three dimensional space - a  
preliminary report. Bull. Prosthetic Res.

17 (2) 10-34.

VELOCITIES (Y-DIRECTION).  
RIGHT FEMUR

2000.

mm/seo.

150005. JT  
150005. JT  
150005. JT

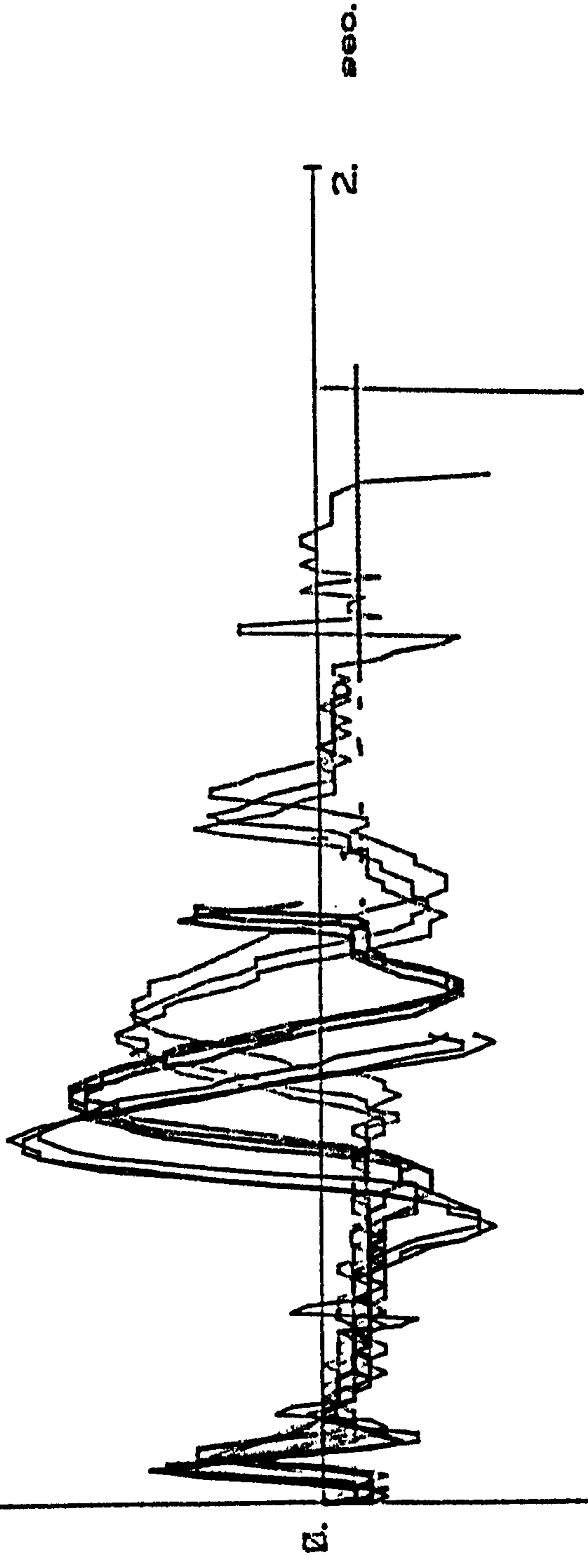

Figure 41

-2000.