

Zhong, Silin (2007) Protein localization and interactions in the tomato ethylene signalling pathway. PhD thesis, University of Nottingham.

Access from the University of Nottingham repository:

<http://eprints.nottingham.ac.uk/10405/1/Thesis.pdf>

Copyright and reuse:

The Nottingham ePrints service makes this work by researchers of the University of Nottingham available open access under the following conditions.

- Copyright and all moral rights to the version of the paper presented here belong to the individual author(s) and/or other copyright owners.
- To the extent reasonable and practicable the material made available in Nottingham ePrints has been checked for eligibility before being made available.
- Copies of full items can be used for personal research or study, educational, or not-for-profit purposes without prior permission or charge provided that the authors, title and full bibliographic details are credited, a hyperlink and/or URL is given for the original metadata page and the content is not changed in any way.
- Quotations or similar reproductions must be sufficiently acknowledged.

Please see our full end user licence at:

http://eprints.nottingham.ac.uk/end_user_agreement.pdf

A note on versions:

The version presented here may differ from the published version or from the version of record. If you wish to cite this item you are advised to consult the publisher's version. Please see the repository url above for details on accessing the published version and note that access may require a subscription.

For more information, please contact eprints@nottingham.ac.uk

Protein Localization and Interactions in the Tomato Ethylene Signalling Pathway

By Silin Zhong BSc MSc

Thesis submitted to the University of Nottingham for the degree of Doctor
of Philosophy, July 2007

ACKNOWLEDGEMENTS

This thesis would not have been completed without the assistance from everyone in the RPG Lab and all the support from my friends and family. In particular, I would like to thank my supervisor Professor Don Grierson for the opportunity to work in his excellent research group and his invaluable and indispensable guidance throughout this research project. Many thanks also to my laboratory supervisor Dr. Zhefeng Lin for her consistent training and teaching during my study.

“The Impossible Dream” from Man of La Mancha

This is my quest
To follow that star
No matter how hopeless
No matter how far

.....Joe Darion

TABLE OF CONTENTS

CHAPTER 1: INTRODUCTION	1
1.1 Ethylene as a Phytohormone	1
1.1.1 Properties of ethylene	1
1.1.2 Ethylene biosynthesis	2
1.2 Ethylene Signalling	4
1.2.1 <i>Arabidopsis</i> ethylene receptors.....	5
1.2.2 Copper mediated ethylene binding	7
1.2.3 <i>Arabidopsis</i> ethylene receptor mutants.....	9
1.2.4 Ethylene receptors: two-component system histidine kinase?	10
1.2.5 <i>Arabidopsis</i> CTR1	14
1.2.6 ETR1-CTR complex.....	16
1.2.7 Components downstream of the receptor-CTR complex	22
1.3 Ethylene Signalling in Tomato	25
1.3.1 Fruit ripening	25
1.3.2 Ethylene mutants affecting tomato fruit ripening.....	28
1.3.3 Tomato ethylene receptors and CTRs.....	29
1.3.4 LeCTR2 and the IntCR clones.....	32
1.4 Objectives	37
CHAPTER 2: MATERIALS AND METHODS	38
2.1 Chemicals	38
2.2 Plant Materials and Growth Conditions	38
2.3 Plant Transformations	39
2.3.1 Tomato transformation.....	39
2.3.2 Tobacco transformation	41
2.3.3 <i>Arabidopsis</i> transformation	41
2.4 Genomic DNA Extraction	42
2.4.1 MiniPrep	42

2.4.2 Phenol-chloroform method.....	43
2.5 RNA Extraction	44
2.5.1 MiniPrep	44
2.5.2 Phenol-chloroform method.....	44
2.6 GEL Electrophoresis	46
2.6.1 Non-denatured agarose gel	46
2.6.2 DNA extraction from agarose gel.....	46
2.7 Polymerase Chain Reaction	47
2.7.1 General PCR protocol for <i>Taq</i>	47
2.7.2 General PCR protocol for Accuzyme	47
2.7.3 General PCR protocol for Phusion	48
2.7.4 PCR from leaf extract	48
2.8 Cloning DNA into Plasmid Vectors.....	48
2.8.1 Ligation.....	48
2.8.2 Gateway cloning	49
2.8.3 Preparation of competent <i>E. coli</i> cells	50
2.8.4 <i>E. coli</i> transformation	51
2.8.5 Plasmid preparation	51
2.9 Southern Blot.....	53
2.9.1 Genomic DNA digestion	53
2.9.2 Electrophoresis and blotting	53
2.9.3 Hybridization	54
2.9.4 Development of autoradiography film	56
2.9.5 Stripping the blot	56
2.9.6 Preparation of salmon sperm DNA	57
2.10 Northern Blot.....	57
2.10.1 Electrophoresis of RNA.....	57
2.10.2 Upward capillary blotting.....	58
2.11 Western Blot.....	59
2.11.1 SDS-polyacrylamide gel electrophoresis.....	59
2.11.2 Western blot	60
2.12 Reverse Transcription.....	61
2.13 Yeast Two-Hybrid Assay	62

2.13.1 Transformation of yeast	63
2.13.2 LexA-based yeast two-hybrid assay	64
2.13.3 GAL4-based yeast two-hybrid assay	66
2.14 Protein Synthesis and Purification in Yeast	68
2.15 Microscopy	69
2.15.1 Confocal scanning microscopy	69
2.5.2 Transient expression in onion epidermal cells	71
2.15.3 Forster resonance energy transfer (FRET)	72
CHAPTER 3: RESULTS	75
3.1 Introduction	75
3.1.1 Yeast Two-Hybrid System	75
3.1.2 Fluorescent Proteins	77
3.2 Sequence Analysis of IntCR	80
3.2.1 The 5' end sequence of IntCR242 and 266	80
3.2.2 Sequence analysis of IntCR242 and IntCR266	82
3.2.3 Sequence analysis of IntCR22	85
3.3 Expression of IntCR Genes	87
3.3.1 IntCR242 is not alone	87
3.3.2 Expression patterns of IntCR	89
3.3.3 The <i>IntCR22</i> is up-regulated by SA	92
3.4 Analysis of Yeast Two-Hybrid Interactions	92
3.4.1 The His-rich domain is responsible for the interaction of IntCR242	92
3.4.2 IntCR242 associates with other IntCR proteins	96
3.5 IntCR266 Complements the <i>Arabidopsis</i> Mutant <i>var1-1</i>	98
3.6 Sub-cellular Localization of IntCR	101
3.6.1 Constructs	101
3.6.2 IntCR242 and IntCR266 are targeted to chloroplast	103
3.6.3 Cytoplasmic localization of IntCR22	107
3.7 Localization of LeCTR2 and LeETR1	110

3.7.1 Cytoplasmic localization of LeCTR2 and AtEDR1	111
3.7.2 LeETR1 is located to the ER	117
3.7.3 IntCR22 co-localized but showed no FRET with LeCTR2.....	119
3.8 Re-examination of the Protein-Protein Interactions.....	123
3.8.1 The G238E mutated LeCTR2.....	123
3.8.2 Interaction between receptors and CTRs.....	128
3.9 Transient Expression of Fluorescent Proteins	133
3.9.1 Generating the CFP/GFP/YFP series of plasmids.....	133
3.9.2 Generating gateway cloning vectors: pDH51-GW-FP	136
3.9.3 Construction of the BiFC vectors and modified pGreenII binary vectors.....	138
3.10 Localization of Ethylene Receptors and CTRs.....	140
3.10.1 The tomato ethylene receptors are targeted to the ER.....	140
3.10.2 NR dependent ER localization of CTR1, 3 and 4.....	146
3.10.3 Biomolecular fluorescence complementation (BiFC)	150
3.11 Summary	157
CHAPTER 4: DISCUSSION	159
4.1 Background.....	159
4.2 IntCR22.....	160
4.2.1 IntCR22 encodes a UDP-glycosyltransferase.....	160
4.2.2 Possible biological functions of IntCR22.....	162
4.2.3 Sub-cellular localization of IntCR22.....	164
4.3. IntCR266 and IntCR242	167
4.3.1 IntCR266 is a functional chloroplast FtSH proteinase	167
4.3.2 IntCR242 is also a chloroplast protein	168
4.3.3 Are the IntCR clones artefacts of the yeast two-hybrid screen?.....	169
4.4 Interaction between Tomato Ethylene Receptors and CTRs.....	170
4.4.1 Mutation in the CN motif of LeCTR2 does not abolish its interaction	170
4.4.2 Receptor NR dependent localization of LeCTR1, 3 and 4 in onion cells	172
4.4.3 Forster Resonance Energy Transfer (FRET)	174
4.4.4 Biomolecular Fluorescence Complementation (BiFC)	176
4.4.5 BiFC assay reveals the interaction between receptors and CTRs	178
4.4.6 Tomato ethylene receptor-CTR interaction: an overview.....	180

4.6 Future Work	185
REFERENCES.....	190
APPENDIX	200

LIST OF FIGURES

Figure 1.1: Ethylene biosynthesis pathway.....	3
Figure 1.2: Triple-response	4
Figure 1.3: The <i>Arabidopsis</i> ethylene receptors	6
Figure 1.4: Model of the ethylene binding site	8
Figure 1.5: Diagram of the two-component system.....	11
Figure 1.6: Model for ethylene receptor membrane topology	17
Figure 1.7: Possible model of the ethylene receptor-CTR complex	20
Figure 1.8: Possible model of the single GOF receptor mutant.....	21
Figure 1.9: Linear ethylene signalling pathway in <i>Arabidopsis</i>	24
Figure 1.10: Tomato ethylene receptors	30
Figure 1.11: Phylogenetic tree of CTR-like proteins	31
Figure 2.1: Blotting assembly	54
Figure 3.1: The LexA-based yeast two-hybrid system	76
Figure 3.2: RACE-PCR products of IntCR 242 and 266.....	81
Figure 3.3: Amino acid sequence alignment of IntCR242.....	83
Figure 3.4: Amino acid sequence alignment of IntCR266.....	84
Figure 3.5: <i>Arabidopsis</i> homologues of IntCR22	86
Figure 3.6: Southern blot of IntCR242	88
Figure 3.7: Northern analysis of IntCR over a 24 h period.....	90
Figure 3.8: Expression of IntCR in the dark/light grown seedlings.....	91
Figure 3.9: SA induced expression of IntCR22	91
Figure 3.10: Schematic diagram of IntCR242 constructs	94
Figure 3.11: Yeast two-hybrid assay of IntCR242	95
Figure 3.12: The His-rich region in IntCR242.....	95
Figure 3.13: Interaction between IntCR proteins.....	97
Figure 3.14: T-DNA region of the pGWB plasmids	99
Figure 3.15: IntCR266 transgene rescued the <i>var1-1</i> mutant phenotype	100

Figure 3.16: T-DNA region of binary vector pK7FWG2.....	102
Figure 3.17: IntCR242-GFP in transgenic tobacco leaf epidermal cells.....	104
Figure 3.18: IntCR242 in the stromule of the transgenic tobacco cells.....	105
Figure 3.19: Localization of AT1G15730 and IntCR266 in transgenic tobacco.....	106
Figure 3.20: Localization of IntCR22-EGFP.....	108
Figure 3.21: Localization of AT2G36780-EGFP.....	109
Figure 3.22: LeCTR2 ¹⁻⁹⁸ -EGFP localized to the cytoplasm and nucleus.....	113
Figure 3.23: Localization of LeCTR2 ¹⁻⁹⁸ -GFP in the guard cells.....	114
Figure 3.24: Localization of LeCTR2 ¹⁻⁹⁸ -GFP in hypocotyl cells.....	115
Figure 3.25: AtEDR1 ¹⁻⁶⁰⁵ was located to the cytoplasm and nucleus.....	116
Figure 3.26: LeETR1 and LeEIN2 were targeted to the ER.....	118
Figure 3.27: Co-localization of LeCTR2 with IntCR22.....	120
Figure 3.28: No FRET between IntCR22 and LeCTR2.....	121
Figure 3.29: FRET positive control.....	122
Figure 3.30: PCR mutation (Gly ²⁸³ to Glu) of the CN motif in LeCTR2.....	126
Figure 3.31: Gly ²³⁸ to Glu mutated LeCTR2 in the yeast two hybrid-assay.....	127
Figure 3.32: LeCTR2 does not interact with the ethylene receptors.....	130
Figure 3.33: LeCTR3 interacts with sub-family I ethylene receptors.....	131
Figure 3.34: Gly ³⁴⁷ to Glu mutated LeCTR3 in the yeast two-hybrid assay.....	132
Figure 3.35: pDH51 plasmid.....	134
Figure 3.36: pDH51-x-FP plasmid.....	135
Figure 3.37: pDH51-GW-FP plasmids.....	137
Figure 3.38: Schematic diagram of BiFC vectors.....	139
Figure 3.39: Never-Ripe was localized to the ER membrane in the onion cell.....	142
Figure 3.40: ETR4 was localized to the ER of the onion epidermal cell.....	143
Figure 3.41: NR protein aggregation after prolong expression.....	144
Figure 3.42: LeETR1 was targeted to the ER in onion cells.....	145
Figure 3.43: LeCTR alone was targeted to cytoplasm and nucleus.....	147
Figure 3.44: LeCTR1, 3 and 4 co-localized with NR in the ER membrane.....	148
Figure 3.45: LeCTRs did not co-localize with ER-CFP.....	149

Figure 3.46: Biomolecular fluorescence complementation (BiFC).....	153
Figure 3.47: BiFC assay of the receptor NR with CTR1 and CTR2.....	154
Figure 3.48: BiFC assay of the receptor ETR1 with 4 CTRs.....	155
Figure 3.49: LeCTR2-YFPC showed positive BiFC with YFPN	156
Figure 4.1: Schematic diagram of FRET between two interacting proteins	176
Figure 4.2: Schematic diagram of BiFC between two interaction proteins	179
Figure 4.3: Proposed model of ethylene signalling in a tomato cell.....	189

LIST OF TABLES

Table 1.1: Physical and chemical properties of ethylene	1
Table 1.2: The IntCR clones.....	33
Table 2.1: Washing the membrane	55
Table 2.2: Recipe for SDS-PAGE gel	59
Table 2.3: Excitation and emission settings	70
Table 3.1: Primers for PCR amplification of the IntCR242 constructs.....	94
Table 3.2: Software prediction of the LeCTR2 localization	112
Table 4.2: Ethylene receptor-CTR interactions confirmed by fluorescent protein based methods	184

ABBREVIATIONS

2-4,D	2,4-Dichlorophenoxyacetic acid
ACC	1-aminocyclopropane-1 carboxylic acid
ACO	ACC oxidase
ACS	ACC synthase
AdoMet	S-adenyl-methionine
Ala	Alanine
Asp	Aspartic acid
APS	Ammonium persulfate
BiFC	Biomolecular fluorescence complementation
bp	Base pair
BA	Benzylaminopurine
BR	Brassionsteroids
CaMV	Cauliflower mosaic virus
cDNA	Complementary DNA
CDS	Coding sequence
cTP	Chloroplast transit peptide
CTR	Constitutive triple response
DNA	Deoxyribonucleic acid
DNase	Deoxyribonuclease
dNTP	2' deoxynucleotide 5'-triphosphate
DMSO	Dimethyl sulfoxide
DTT	Dithiothreitol
<i>E. coli</i>	<i>Escherichia coli</i>
EBF	EIN3 binding factor
EDR1	Enhanced disease response1
EDTA	Disodium ethylene diamine tetraacetate
EIN	Ethylene insensitive

ER	Endoplasmic reticulum
ETR	Ethylene response
FRET	Forster resonance energy transfer
GAF	Motif found in cGMP phosphodiesterase, <u>a</u> denylyl cyclase and <u>F</u> hla
GFP	Green fluorescent protein
Glu	Glutamic acid
Gly	Glycine
GOF	Gain-of-function
GR	Green-ripe
GST	Glutathione-S-transferase
His	Histidine
IAA	Indole-3-acetic acid
IntCR	Interacting with CTR2
LOF	Loss-of-function
M	Molar
MAPKKK	Mitogen-activated protein kinase kinase kinase
MET	Methionine
MS salt	Murashige-Skoog salt
mRNA	Messenger RNA
MTA	Methylthioadenine
NAA	1-Naphthaleneacetic acid
NR	Never-ripe
°C	Degree Celsius
ppm	Parts per million
POI	Protein of Interest
psi	Pounds per square inch
RAN1	Responsive to antagonist1
RNA	Ribonucleic acid
RNase	Ribonuclease

ROI	Region of Interest
RT	Room temperature
SDS	Sodium dodecyl sulphate
SDW	Sterile distilled water
Ser	Serine
SSC	Sodium salt citrate buffer
SSPE	Sodium salt phosphate EDTA buffer
TAE buffer	Tris/Acetate/EDTA buffer
TBE buffer	Tris/Borate/EDTA buffer
TEMED	Tetramethylethylenediamine
Thr	Threonine
Tris	Tris-(hydroxymethyl)-methylamine
UGT	UDP-glycosyltransferase
UV	Ultra violet
ZON	Zearalenone

ABSTRACT

Early studies of the tomato ethylene signalling network using yeast two-hybrid screen previously identified three novel proteins (IntCR22, 242 and 266) that could interact with a putative ethylene kinase LeCTR2 (Lin *et al.*, 2003). In this study, it has been demonstrated that IntCR22 is a cytoplasmic UDP-glycosyltransferase and IntCR266 is a chloroplast metallo-proteinase homologue to the *Arabidopsis* FtSH5/VAR1, whereas IntCR242 encodes a novel chloroplast protein with a C-terminal histidine-rich domain. In order to gain more insight into the tomato ethylene signalling mechanism, the sub-cellular localization and protein-protein interactions of the tomato ethylene signalling components have been investigated by fluorescent protein labelling and yeast two-hybrid experiments. Three tomato ethylene receptors (ETR1, NR and ETR4) and a downstream regulator EIN2 have been found in the endoplasmic reticulum (ER). Three putative downstream MAPKK kinases (CTRs) could interact with the C-terminus of the ethylene receptor possibly on the cytoplasmic side of the ER, whereas a novel ethylene signalling component GREEN-RIPE was located in the Golgi. It was therefore concluded from the localization study that IntCR242 and IntCR266 were false positives from the yeast two-hybrid screen and could not interact *in vivo* with the ethylene signalling components. The results presented in this study, in line with previous ethylene research suggest a possible involvement of the plant endomembrane system in the ethylene signalling network. However, the question as to how the ethylene signal moves from the ER localized receptors to promote activation of genes for the transcription factors within the nucleus remains unsolved.

CHAPTER 1: INTRODUCTION

1.1 Ethylene as a Phytohormone

1.1.1 Properties of ethylene

Ethylene is an endogenous plant hormone that regulates many aspects of plant growth and development and is critically involved in germination, senescence, abscission, fruit ripening and stress related responses. Ethylene is a gas and has a simple structure, which consists of two carbons and four hydrogens (Table 1.1).

Table 1.1: Physical and chemical properties of ethylene

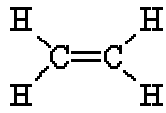
Structure		CAS number	74-85-1
		Molecular weight	28.0536
Melting point	-169.14 °C	Boiling point	-103.7 °C

The boiling temperature of ethylene is -103.7°C , which allows it to remain in gaseous form under all the conditions suitable for plant growth. The solubility of ethylene gas (25°C) is higher in organic environments than in water (O'Neil, 2006), which means that ethylene can diffuse freely through the membrane systems without the need of any carrier protein. The lowest concentration required for the biological activity of ethylene in the literature is 10^{-2} ppm and it has been suggested that 1 ppm of ethylene is sufficient to evoke ethylene responses such as inhibition of root/hypocotyl growth in etiolated *Arabidopsis* seedlings (Keegan *et al.*, 1988; Binder *et al.*, 2004). This is a

lower concentration than most if not all the signalling molecules with identified hormone functions in plants.

The unique chemical and physical characteristics of ethylene make it possible as a signal molecule to diffuse freely to any part of the plant cell. Therefore, ethylene could be synthesized by some cells under specific physiological or developmental conditions and diffuse to a target tissue to evoke ethylene responses. All these properties contribute to ethylene's special physiological significance. It is unique among the major plant growth regulators and it is also one of the most extensively studied phytohormones.

1.1.2 Ethylene biosynthesis

Although elucidation of the signalling apparatus is important in understanding how ethylene or any signalling molecule functions and affects development, it is equally important to understand how the signal molecule is produced and how the production process is regulated. The precursor for ethylene biosynthesis is S-adenosyl-methionine (AdoMet), which is converted from methionine by the AdoMet synthase through an ATP dependent process (Figure 1.1; Yang and Hoffman, 1984). AdoMet is an intermediate in a number of biosynthetic pathways as a methyl donor and is also involved in the methylation of proteins, lipids and nucleic acids. The conversion of AdoMet to 1-aminocyclopropane-1-carboxylic acid (ACC) by the ACC synthase (ACS) is the first committed step in the ethylene synthesis cycle (reviewed in Alexander and Grierson, 2002). Secondly, ACC is oxidized by ACC oxidase (ACO, previously called Ethylene

Forming Enzyme) to produce ethylene, CO₂ and cyanide (Holdsworth *et al.*, 1987; Halmiton *et al.*, 1991). Cyanide is a toxic by-product of ethylene synthesis and is rapidly metabolized to β-cyanoalanine derivatives by β-cyanoalanine synthase (Yip and Yang, 1988). To control ethylene production, both ACS and ACO are regulated at the transcriptional and post-transcriptional levels in response to environmental stimuli and developmental cues (reviewed in Wang *et al.*, 2002). For example, the stability and activity of ACS were controlled post-transcriptionally by the ETO1 and ETO1-like (EOL) proteins that can physically interact with the C-terminus of ACS and target ACS for proteasome degradation (Wang *et al.*, 2004).

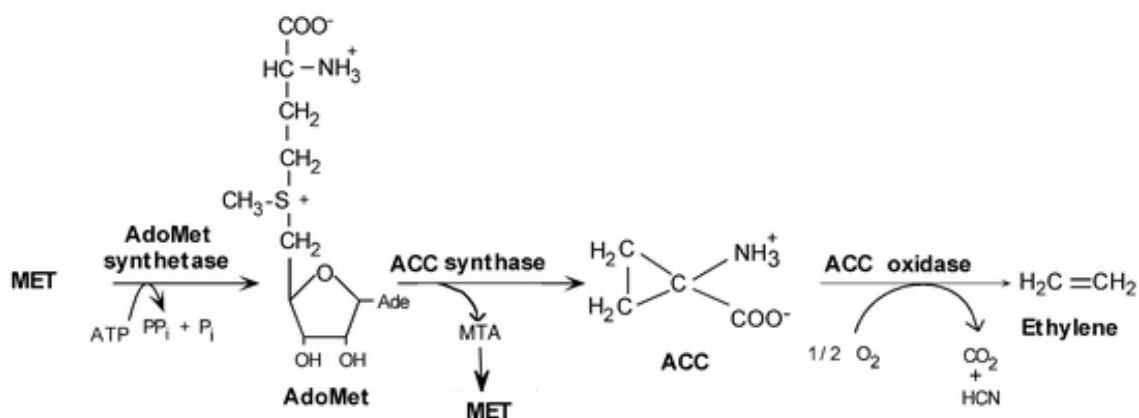

Figure 1.1: Ethylene biosynthesis pathway

The ethylene biosynthesis pathway is also known as the “Yang Cycle”. Methionine is first converted to S-adenyl-methionine by AdoMet synthetase, then to ACC and finally oxidized to generate ethylene. The methyl group in AdoMet is finally recycled back to Met and Yang Cycle is completed. The enzymes catalyzing each step are shown above the arrows. AdoMet: S-adenyl-methionine; MET: methionine; ACC: 1-aminocyclopropane-1-carboxylic acid; MTA: methylthioadenine (Schaller and Kieber, 2002).

1.2 Ethylene Signalling

The signalling pathway of ethylene has been dissected in great detail in the model plant *Arabidopsis thaliana* largely by isolating ethylene response mutants and characterizing the mutant genes. Although ethylene affects many developmental processes during plant growth, most of these effects are too cumbersome for mutant screens (Schaller and Kieber, 2002). Thus the “triple-response”, which is a combination of relatively simple effects of ethylene on dark-grown *Arabidopsis* seedlings, is extensively used in genetic screens for ethylene mutants (Bleecker *et al.*, 1988). Briefly, the triple response is characterized by the inhibition of root elongation, production of a shortened and thickened hypocotyl and exaggerated curve of the apical hook of the dark grown *Arabidopsis* seedlings (Figure 1.2).

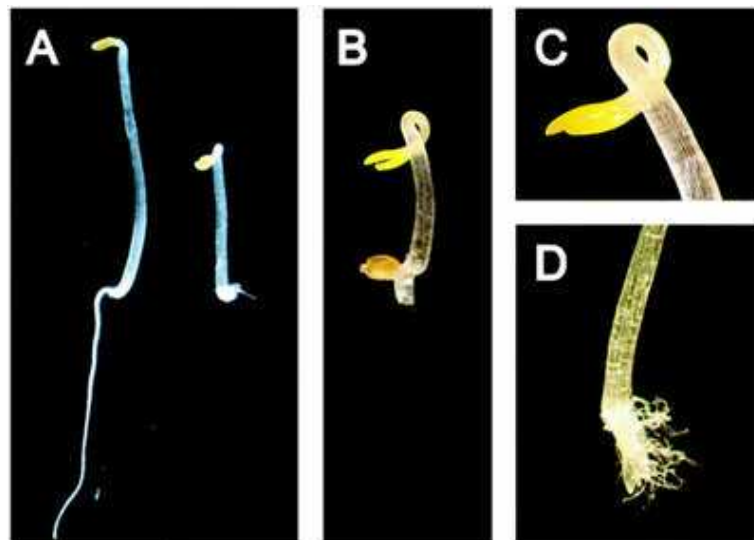

Figure 1.2: Triple-response

(A) *Arabidopsis* seedlings grown in the dark with (right) or without (left) exogenous ethylene. (B) Dark grown seedling in the presence of the ethylene precursor ACC developing triple response. (C and D) Close-up of the apical hook and root of the triple response seedling (Schaller and Kieber, 2002).

Ethylene mutants with an altered triple-response obtained from such screens can be generally separated into two classes. The first class includes ethylene insensitive mutants; the second class comprised the constitutive ethylene response mutants (Bleecker *et al.*, 1988). For example, the *ein2* mutant renders the *Arabidopsis* plant completely ethylene insensitive (Alonso *et al.*, 1999) and is a member of the first mutant class. On the other hand, the second class of mutant *ctr1-1* causes constitutive ethylene response in both seedlings and adult plants (Kieber *et al.*, 1993). With the large genetic mutant resources available, epistatic analysis of the double mutants has been used to determine the genetic order of the signalling components and the framework of the ethylene signalling pathway has been established (reviewed in Schaller and Kieber, 2002; Ecker *et al.*, 2006; Olemdo *et al.*, 2006).

1.2.1 *Arabidopsis* ethylene receptors

In the model plant *Arabidopsis*, ethylene is perceived by a family of five receptors (ETR1, ERS1, ETR2, ERS2 and EIN4) in the membrane of the endoplasmic reticulum (Chang *et al.*, 1993; Hua, *et al.*, 1995; Hua and Meyerowitz, 1998; Sakai *et al.*, 1998). The ethylene binding site is located in the N-terminal transmembrane domains of the receptors, which is followed by a GAF domain and a histidine kinase domain. Although this might not be active in all ethylene receptor-like proteins, an additional receiver domain is present in the C-termini of the *Arabidopsis* ethylene receptors ETR1, ETR2 and EIN4 (Figure 1.3). The GAF domain was originally found in the cyclic nucleotide phosphodiesterases and subsequently recognized in the phytochromes of

cyanobacterium and higher plants (Charbonneau *et al.*, 1990; Aravind and Ponting, 1997). Although, it has been suggested that the GAF domain was involved in binding small molecules such as cGMP, its role in the ethylene receptors is still unclear. Recently, it has been reported that the GAF domain might mediate the non-covalent dimerization of the *Arabidopsis* ethylene receptor ETR1 (Xie *et al.*, 2006). Following the GAF domain, the C-terminal half of the ethylene receptors contains a kinase domain and a receiver domain, which share sequence similarity to the bacterial two-component system histidine kinase. According to the presence of the conserved kinase motifs in the histidine kinase domain, the five ethylene receptors are divided into two subfamilies (Hua and Meyerowitz, 1998). Only the subfamily I receptors (ETR1 and ERS2) have all the essential elements for the histidine kinase activity and the subfamily II receptors have an extra hydrophobic region in the N-terminus, which has been hypothesized for targeting receptors to the secretion pathway (Figure 1.3).

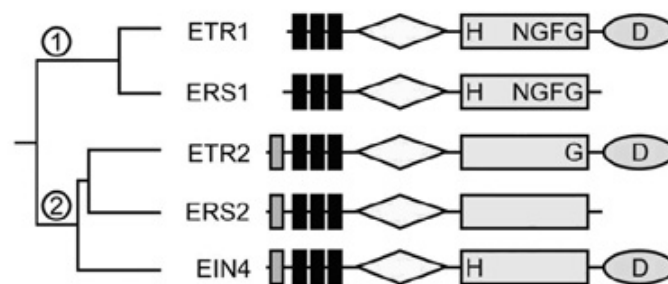

Figure 1.3: The *Arabidopsis* ethylene receptors

The subfamily I receptors (ETR1 and ERS1) have the conserved histidine kinase motifs (HNGFG). The remaining subfamily II receptors have a putative signal sequence for entering the secretion pathway (grey bar). The black bar indicates the transmembrane domain, the diamond represents the GAF domain, the rectangle indicates the histidine kinase domain and the oval with the conserved Asp (D) indicates the receiver domain (Schaller and Kieber, 2002).

1.2.2 Copper mediated ethylene binding

A schematic diagram of the current model of ethylene binding is shown in Figure 1.4. It has been suggested that the ethylene receptors dimerize by covalent disulfide linkage and their dimerization is required for ethylene binding (Schaller and Bleecker, 1995; Hall *et al.*, 1999; Rodriguez *et al.*, 1999). It is also hypothesized that ethylene binds to the dimerized receptor through a copper co-factor and the copper ion was supplied to the ethylene receptors by the *Arabidopsis* RESPONSIVE TO ANTAGONIST1 (*RAN1*) protein, which is a copper-transporting P-type ATPase (Hirayama *et al.*, 1999). This is supported by the observations that the loss-of-function mutants of *RAN1* and transgenic plants with reduced *RAN1* messenger RNA level have constitutive ethylene response phenotypes.

Applying exogenous copper ion to the growth medium could partially rescue the constitutive ethylene response phenotype of *ran1-3*, which suggested that the constitutive ethylene response of the loss-of-function *ran1-3* mutant was resulted from the inappropriate or insufficient copper ion delivery to the ethylene receptors (Woeste *et al.*, 2000). The epistatic analysis also revealed that the *RAN1* allele acts on or downstream from the ethylene receptors and upstream of *EIN2*, as the *ran1* mutant phenotypes could only be masked by the *ein2* mutation but not the mutations in the ethylene receptors.

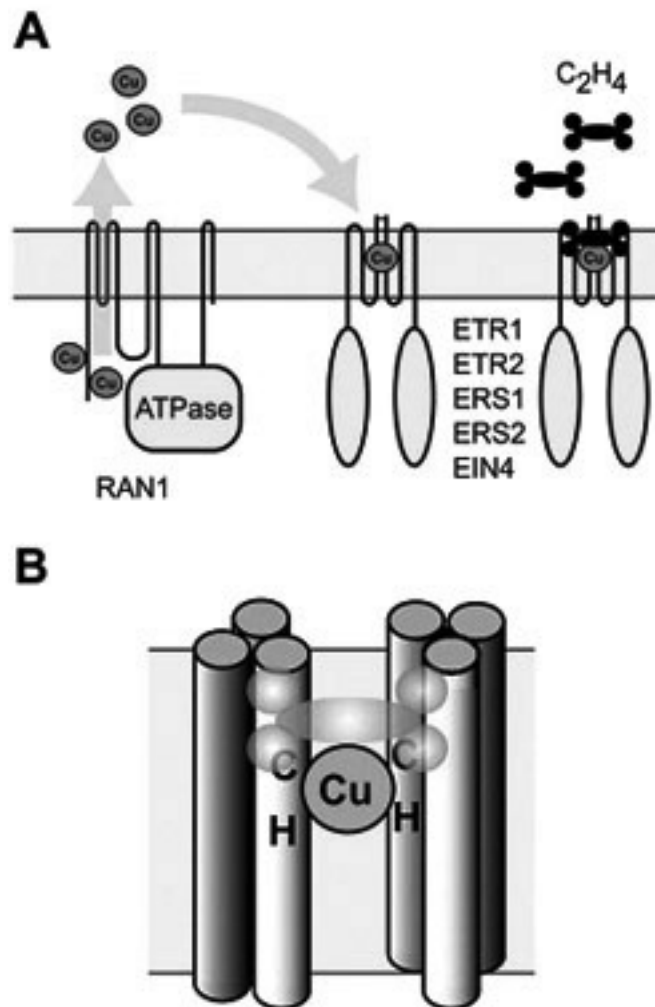

Figure 1.4: Model of the ethylene binding site

(A) Copper loading of ethylene receptors by RAN1. RAN1 is a copper transporting ATPase with two N-terminal metal-binding motifs that can bind copper and transport it across the membrane to the ethylene receptor apoproteins. It has been suggested that one copper ion is coordinated per receptor homo-dimer to mediate ethylene binding.

(B) Transmembrane structure of the ethylene binding site. There is one copper binding site and consequently one ethylene-binding site per receptor homodimer. Each monomer of the receptor homodimer contains three transmembrane segments. Cys⁶⁵ and His⁶⁹ coordinate the copper ion within the second transmembrane domains of each monomer (Schaller and Kieber, 2002).

1.2.3 *Arabidopsis* ethylene receptor mutants

The *Ethylene Response1* (*ETR1*) gene was the first member of the *Arabidopsis* ethylene receptor gene family to be identified and has been characterized in most detail (Chang *et al.*, 1993). The *ETR1* gene was mapped and cloned from the *etr1-1* mutant, which is one of the dominant gain-of-function (GOF) missense receptor mutants that confer ethylene insensitivity by abolishing ethylene binding (Chang *et al.*, 1993; Hall *et al.*, 1999). *ETR1* is an integral membrane protein with 738 amino acid residues; it contains three transmembrane domains in the N-terminus followed by a GAF domain, a histidine kinase domain and a receiver domain (Figure 1.3).

A second *ETR1* mutant allele, *etr1-2* is the only ethylene receptor mutant where the insensitivity to ethylene is not caused by mutations affecting ethylene binding (Hall *et al.*, 1999). The mutant protein *ETR1-2*, in which the Ala¹⁰² is changed to Thr in the third trans-membrane domain, can bind ethylene in excess of wild-type *ETR1* protein. It has been demonstrated that the *etr1-2* mutant phenotype could be suppressed by the *reversion-to-ethylene sensitivity1* (*rte1*) mutant, which encodes a novel plant membrane protein (Resnick *et al.*, 2006). Interestingly, *rte1* could only suppress *etr1-2* but not the *etr1-1* allele nor can it suppress other receptor mutants. In addition, the *etr1-2/rte1* double mutant resembles both the *ETR1* and *RTE1* loss-of-function mutants, which have enhanced ethylene responses. Taken together with the findings that over-expressing *RTE1* resulted in reduced ethylene sensitivity, it appears that *RTE1* might negatively regulate the ethylene signalling through the ethylene receptor *ETR1*

and has an essential role in ETR1 function. However, these findings also suggest that the ethylene signal output of ETR1 could be separated into the RTE1 dependent and RTE1 independent ones, since not all *etr1* alleles could be suppressed by *rte1* (Resnick *et al.*, 2006).

The gain-of-function (GOF) mutants of *ETR1* and the other four *Arabidopsis* ethylene receptor genes have a dominant ethylene insensitive phenotype (Bleecker *et al.*, 1988). The loss-of-function (LOF) mutants of any individual receptor genes have no obvious ethylene-related phenotype, while LOF mutants of multiple ethylene receptors have strong constitutive ethylene response phenotype (constitutive triple response) in the absence of ethylene (Hua and Meyerowitz, 1998; Hall and Bleecker, 2003). The difference between the single and multiple LOF mutants suggests that there is functional redundancy within the ethylene receptor family because the constitutive ethylene response phenotype is only observed in multiple receptor LOF mutants. Secondly, it indicates that the ethylene receptors serve as negative regulators of the ethylene signalling pathway because elimination of receptors activates the ethylene response.

1.2.4 Ethylene receptors: two-component system histidine kinase?

The carboxyl termini of the ethylene receptors are similar to histidine kinases of the bacterial two-component system. Typically, the bacterial two-component system is composed of a sensory histidine kinase and a response regulator (Figure 1.5). The sensory histidine kinase is normally a membrane-bound receptor, which

autophosphorylates on a conserved His residue. In response to a specific environmental stimulus, the phosphoryl group at the His residue of the receptor would be transferred to a conserved Asp residue in the response regulator (receiver), such as a transcription factor the activity or localization of which could be altered by the phosphorylation (reviewed in Takeshi *et al.*, 2000; Schaller *et al.*, 2002).

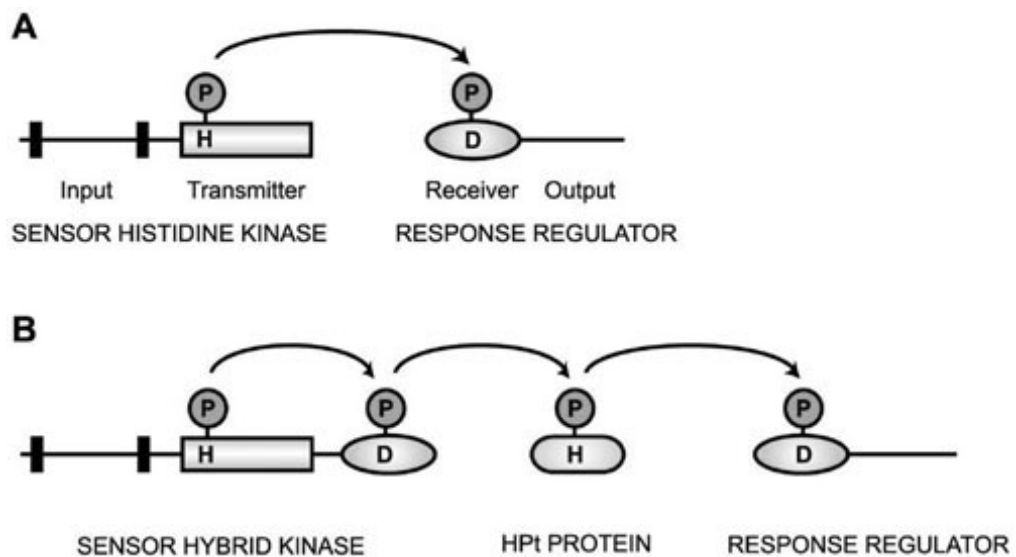

Figure 1.5: Diagram of the two-component system

(A) The two-component system employs a histidine kinase and a response regulator.

(B) The multi-step two-component system employs a hybrid histidine kinase with histidine kinase domain and receiver domain, a histidine-containing phosphotransfer protein (HPt), and a response regulator.

Histidine kinase domains are indicated by rectangles, receiver domains by ovals, HPt proteins by rounded rectangles, and transmembrane domains by black bars. The phosphoryl transfer between histidine (H) and aspartic acid (D) residues are indicated by arrows. (Schaller *et al.*, 2002).

Sometimes a phosphorelay intermediate is required for transferring the phosphoryl group to the response regulator in a multi-step two-component system (Figure 1.5). The sensory histidine kinase of this system usually contains a response domain with a conserved Asp residue, thus it is also referred to as “hybrid histidine kinase”. Three *Arabidopsis* ethylene receptors (ETR1, ETR2 and EIN4) are similar to the hybrid histidine kinase (Figure 1.3), which have the receiver domain, while the ERS1 and ERS2 lack the receiver domain and thus belong to the simple two-component system histidine kinase.

Although the *in vitro* autophosphorylation of all the *Arabidopsis* ethylene receptors has been demonstrated experimentally, neither the response regulator nor the phosphorelay intermediate of the ethylene receptors resembling the two-component system has yet been identified (Mosatche and Klee, 2004). In fact, only the *Arabidopsis* sub-family I ethylene receptors (ETR1 and ERS1) have all the conserved motifs required for the histidine kinase activity and can autophosphorylate on His residue, whereas the remaining sub-family II receptors can only autophosphorylate on the Serine (Ser) residue, which is unconventional for a histidine kinase in the two-component system. It appears that the sub-family II receptors lack the histidine kinase activity but this does not prevent them from participating in the ethylene signalling output, because it has been shown that mutations in the subfamily II receptors could also render the *Arabidopsis* plant insensitive to ethylene (Chang *et al.*, 1993; Hua, *et al.*, 1995; Hua and Meyerowitz, 1998; Sakai *et al.*, 1998).

Moreover, expressing only the N-terminus of the mutant receptor ETR1-1, which lacks the entire histidine kinase domain can mimic the ethylene insensitive phenotype in the wild-type *Arabidopsis* (Gamble *et al.*, 2002). It had been proposed by Wang *et al.*, (2003) that the canonical histidine kinase activity of ETR1 is not required for ethylene signalling by demonstrating that a kinase inactive form of ETR1 could complement the *etr1-7/ers1-2* loss-of-function double mutant. However, interpretation of this complementation experiment remains arguable as it has been discovered that the LOF *ERS1* mutant (*ers1-2*) was, in fact, not a complete null mutant (Xie *et al.*, 2006). Therefore, the constitutive ethylene response phenotype of the leaky *etr1-7/ers1-2* double LOF mutant is an indication that the reduced ERS1 protein level in the *ETR1-7* null background is insufficient to suppress the ethylene response (able to cause constitutive ethylene response). It was hypothesized that the kinase inactive *ETR1* transgene used by Wang *et al.*, (2003) might have utilized the histidine kinase activity from the residual ERS1 protein from the leaky *ers1-2* to restore the normal ethylene signalling. It would thus be interesting to know whether the same kinase inactive *ETR1* transgene could rescue a true *etr1/ers1* LOF mutant such as the recently isolated *etr1-7/ers1-3* (Qu *et al.*, 2007).

Qu and Schaller (2003) showed that neither the truncated *ETR1* (minus the histidine domain) nor the point mutated full-length *ETR1* (lacks histidine kinase activity) could fully rescue the *etr1/ein4/etr2* triple mutant. Furthermore, it has recently been demonstrated that the ethylene insensitivity caused by expressing the mutated ethylene

receptor N-terminus (minus the histidine kinase domain) is sub-family I dependent (Xie *et al.*, 2006). Collectively, these recent findings suggest that the sub-family II receptors alone (lacking the conserved kinase motifs, thus unable to take part in phosphorelay) might not be able to transmit the ethylene signal. In other words, the histidine kinase activities of the receptors are essential in the ethylene signalling output. If that is indeed the case, a key question would be how the sub-family II receptors function without histidine kinase activity.

The biochemical and genetic evidence suggested that the ethylene receptors have sequence homology to the two-component system histidine kinase and their histidine kinase activity might be required for the activity of ETR1. It is still unknown whether or not the ethylene signal transduction takes place through a histidine kinase phosphorelay mechanism and the role of the histidine kinase domain in the ethylene receptors remains largely elusive.

1.2.5 *Arabidopsis* CTR1

The *Arabidopsis* CTR1 protein is a negative regulator of the ethylene signalling pathway. The phenotypes of the *CTR1* LOF mutant *ctr1-1* include small rosette leaves, early bolting (1-2 weeks), sterile early flowers, less extensive root system and a small inflorescence, which can be phenocopied by applying exogenous ethylene to wild-type *Arabidopsis* (Kieber *et al.*, 1993; Clark *et al.*, 1998). The gene *CTR1* spans 5 kb of

genomic DNA and contains 15 introns. The coding sequence of *CTR1* is 2466 nt in length and encodes a protein about 90 kDa. Although, the N-terminal domain of CTR1 displays little sequence similarity to any known proteins, except for other plant CTR1-like proteins, the carboxyl terminus of CTR1 has high sequence similarity to Raf serine/threonine protein kinase (Kieber *et al.*, 1993). The missense mutations in the highly conserved residues in the C-terminal kinase domain of CTR1 could produce the constitutive ethylene response phenotype, which indicates that CTR1 functions as a protein kinase in the ethylene signalling network (Huang *et al.*, 2003).

Epistatic analysis of the double mutants of the receptors and CTR1 revealed that CTR1 acts genetically downstream of the ethylene receptors (Kieber *et al.*, 1993). It was later discovered that the N-terminus of CTR1 can interact directly with the subfamily I ethylene receptors ETR1 and ERS1 by using yeast two-hybrid and *in vitro* pull-down assays (Clark *et al.*, 1998). It should be noted that CTR1 might also associate weakly with the subfamily II receptor ETR2 in the yeast two-hybrid assay (Cancel and Larsen, 2002). It has been postulated that eight out of nine *CTR1* mutants were loss-of-function mutants or contain missense mutations in the kinase domain (Huang *et al.*, 2003). For example, mutations in the conserved kinase residues (*ctr1-1*, *ctr1-4* and *ctr1-7*), a mutant caused by T-DNA insertion (*ctr1-5*), a mutant disrupting intron splicing (*ctr1-6*) and mutants caused by frame shift and early stop codons (*ctr1-2*, *ctr1-3* and *ctr1-9*) all rendered the *Arabidopsis* plants a constitutive ethylene responsive phenotype in the absence of ethylene. On the other hand, misense mutant *ctr1-8* is the result of a Gly³⁵⁴

to Glu change in its N-terminus, whilst the Ser/Thr kinase activity of the CTR1-8 C-terminus remains intact (Huang *et al.*, 2003). Yeast two-hybrid assay revealed that the Gly³⁵⁴ to Glu mutation in CTR1-8 abolished its interaction with the ethylene receptors ETR1 and ERS1. Together with the observation that the missense *ctr1-8* mutant has the same phenotype as other loss-of-function *ctr1* mutant alleles, it was hypothesized that the protein-protein interaction between the ethylene receptors and CTR1 played a critical role in the ethylene signalling mechanism.

1.2.6 ETR1-CTR complex

The ethylene receptors contain N-terminal hydrophobic domains that could be responsible for their membrane localization (Chang *et al.*, 1993). It has recently been demonstrated that the *Arabidopsis* ethylene receptor ETR1 is predominantly localized to the rough endoplasmic reticulum by experiments using sucrose density gradient centrifugation and immunoelectron microscopy (Chen *et al.*, 2002). A membrane topology model of the ethylene receptor has been proposed by Ma *et al.* (2006) through analyzing the localization of GFP fused melon ethylene receptor CmERS1, which is a homologue of the *Arabidopsis* ethylene receptor ERS1. In this model, the N-terminus of the receptor is facing the inner ER lumen and the histidine kinase domain is exposed to the cytosol (Figure 1.6). According to this topology model, the downstream kinase CTR1, which interacts with the histidine kinase domain of the receptor, would associate with the ethylene receptors on the cytoplasmic side of the ER.

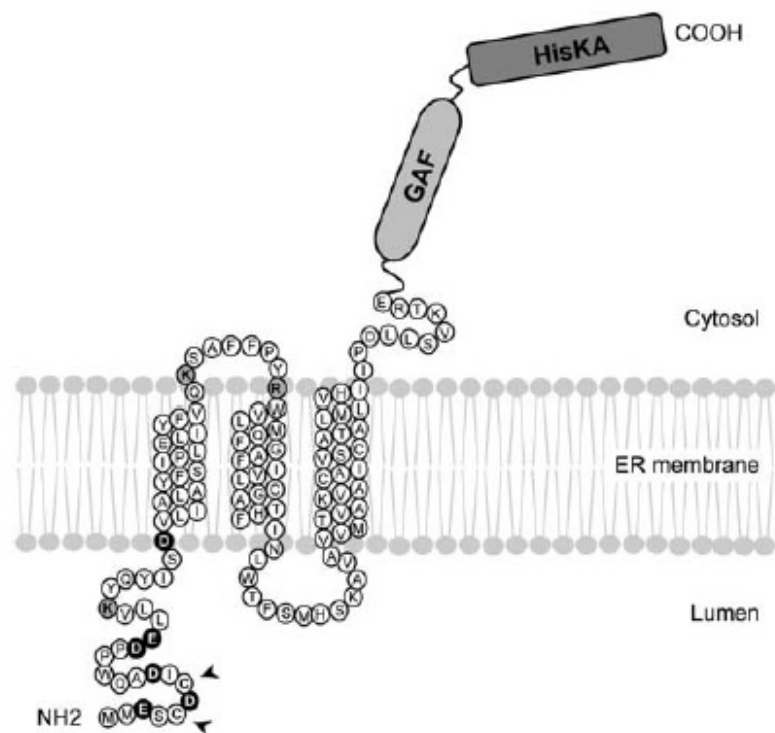

Figure 1.6: Model for ethylene receptor membrane topology

The amino terminus (NH₂) of the receptor faces the ER lumen. The carboxyl terminus (COOH) of the receptor containing the GAF domain and Histidine Kinase domain is exposed to the cytoplasm (Ma *et al.*, 2006).

The *Arabidopsis* CTR1, which could interact with the ethylene receptors ETR1 and ETR2 in the yeast two-hybrid assay (Clark *et al.*, 1998), has also been localized to the ER membrane by sucrose density gradient centrifugation experiment (Gao *et al.*, 2003). In the same study, the authors demonstrated that CTR1 could be co-purified specifically with the ethylene receptor ETR1 from the ER membrane fraction. Since the CTR1 protein does not contain hydrophobic transmembrane domain or endoplasmic reticulum targeting/retention sequences (Kieber *et al.*, 1993), the ER localization of CTR1 is therefore suggested to be mediated by the ethylene receptors at the ER membrane.

Moreover, this is consistent with the observation that the *CTR1-8* mutant protein, which loses its interaction with the receptors, could not be found in the ER (Gao *et al.*, 2003). On this basis, it is likely that there is an ETR1-CTR1 protein complex at the ER membrane as part of the ethylene signalling mechanism. As previously mentioned, multiple loss-of-function mutants of the ethylene receptors have strong constitutive ethylene responses phenotype similar to those of the *CTR1* loss-of-function mutant. Therefore, it is not surprising that the ER membrane associated CTR1 is significantly reduced in these multiple receptor LOF mutants (*etr1/etr2/ein4* and *etr2/ein4/ers2*) (Gao *et al.*, 2003). Meanwhile, the amount of membrane bound CTR1 remained unaffected or even increased in the single ethylene receptor LOF mutants. Thus the authors suggested two non-mutually exclusive models for the ethylene receptor-CTR1 complex:

(1) The N-terminus of CTR1 exerts auto-inhibition over the C-terminal Ser/Thr kinase activity, which could be relieved when the ethylene receptors interact with the N-terminus of CTR1. Once the interaction is abolished (eg. in the *ctr1-8* mutant), the kinase activity of CTR1 could not be switched on and the plant displays a constitutive ethylene response phenotype.

(2) The receptor mediated ER localization of CTR1 is essential for its kinase activity. (eg. to bring CTR1 proximal to its specific substrates near the ER membrane). In this case, the mis-located CTR1-8 could not pass the signal to the downstream substrate and resulted in a phenotype similar to those of the loss-of-function *ctr1* mutants.

However, it is difficult to explain the lack of constitutive ethylene responses in the *etr2/ein4* double receptor LOF mutant that has a decreased level of membrane associated CTR1, while reducing the membrane associated CTR1 in another double receptor LOF mutant *etr1/ers1* did render the plant a constitutive ethylene response phenotype (Gao *et al.*, 2003). In addition, it is not consistent with the current ethylene receptor homodimer model because the remaining receptors in a multiple receptor LOF mutant could still be able to associate with CTR1. Especially in the case of the *etr2/ein4* and *etr2/ein4/ers2* mutants, the receptor ETR1, which has the strongest association with CTR1, remains intact in the ER membrane but there is a significant reduction of membrane associated CTR1 (Gao *et al.*, 2003).

These findings suggest that CTR1 is part of the ethylene receptor signalling complex at the membrane of the endoplasmic reticulum and the recruitment of CTR1 into the receptor complex is essential to negatively regulate ethylene signalling. On these bases, the model of ethylene signalling in the receptor level has been hypothesized (Figure 1.7 and 1.8). However questions remain as to how the ethylene receptors activate CTR1 and what role the histidine kinase domain of the receptors plays in the ethylene signal output, or indeed, how sub-family II receptors, which may not process true histidine kinase activity, actually function. In addition, it should be considered that the current linear model based on the epistatic studies might not be able to faithfully reflect the complicated signalling events during ethylene signalling.

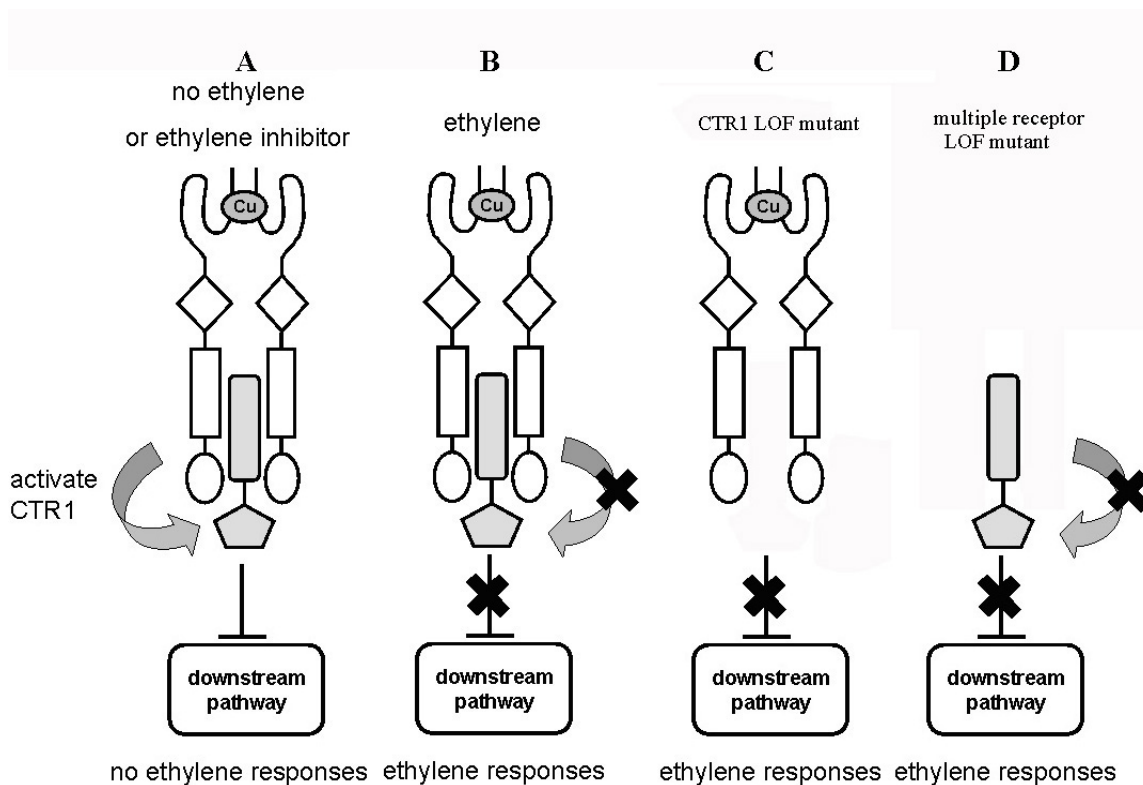

Figure 1.7: Possible model of the ethylene receptor-CTR complex

The receptor ETR1 (white) forms a homodimer in the ER membrane and the ethylene binds to the N-terminus of the receptor dimer through a copper co-factor. The N-terminus of CTR1 (grey) binds to the histidine kinase domain of ETR1.

(A): The receptor activates CTR1 in the absence of ethylene and CTR1 represses the downstream ethylene signalling pathway.

(B): Upon ethylene binding, the ethylene receptors become inactive and CTR1 can not suppress the downstream ethylene signalling.

(C): In the CTR1 LOF mutants, no functional CTR1 protein was produced and the downstream ethylene signalling pathway was always activated thus resulting in constitutive ethylene response phenotype in the absence of ethylene.

(D): In the multiple receptor LOF mutants, no receptor would activate CTR1. Thus, CTR1 is permanently inactive and the ethylene signalling pathway is constantly switched on.

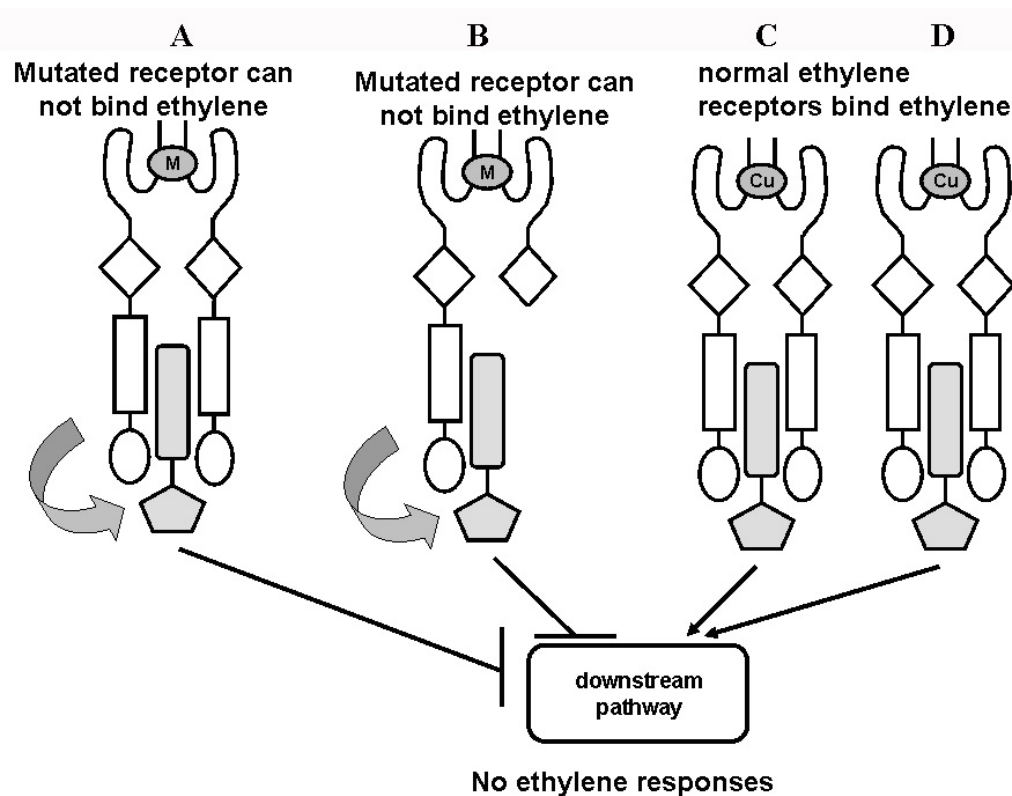

Figure 1.8: Possible model of the single GOF receptor mutant

A: In the single gain-of-function receptor mutant (*e.g. etr1-1*), ethylene could not bind to the receptor and the ethylene receptor would be permanently locked to the active form, which would constantly activate CTR1 to suppress the downstream ethylene signalling network.

B: The wild-type *Arabidopsis* plants expressing the N-terminus of a mutated receptor (indicated by the truncated ETR1 protein lacking the rectangle and oval) are also insensitive to ethylene. It was hypothesized that the truncated mutant receptor could form a dimer with the endogenous full-length wild-type (normal) receptors and pass down the negative signal to suppress the ethylene response.

C and D: Although the remaining ethylene receptors could function normally upon ethylene binding, the downstream ethylene response could not be activated due to the presence of the mutated receptor-CTR1 complex (A and B), which constantly represses the ethylene signalling pathway.

1.2.7 Components downstream of the receptor-CTR complex

A diagram of the ethylene signalling pathway in the model species *Arabidopsis* is schematically outlined in Figure 1.9. The carboxyl terminus of CTR1 has sequence homology to the Raf-like Ser/Thr kinase and mutation abolishing the CTR1 kinase activity renders *Arabidopsis* plants with a constitutive ethylene response phenotype in the absence of ethylene (Kieber *et al.*, 1993). Thus, it has long been hypothesized that a MAPKKK cascade could act downstream of CTR1 to pass on the ethylene signal, although it is unconventional to have a typical eukaryotic Ser/Thr kinase signalling cascade coupled directly downstream of the two-component system histidine kinase, which is prevalent in prokaryotic organisms. A MAPKKK module including MAPK6 and MAPK13 had been proposed by Ouaked *et al.* (2003) to act downstream of CTR1 and this finding of the long-missing MAPKKK cascade attracted great interest from the ethylene research community. However, flaws in the experiment design were discovered and the MAPK6 and MAPK13 turned out to be regulating the ethylene biosynthesis instead of the signalling (Liu and Zhang, 2004; reviewed in Ecker, 2004).

The *ETHYLENE INSENSITIVE2 (EIN2)* mutation is genetically placed downstream of *CTR1*. The loss-of-function mutant of *EIN2* has the strongest ethylene insensitive phenotype identified so far (Alonso *et al.*, 1999). Transgenic *Arabidopsis* plants expressing the soluble carboxyl terminus of EIN2 have partially constitutive ethylene response phenotype but displays normal ethylene responses in the dark grown seedling. It has been suggested that the N-terminus of EIN2 perceives the signal from the

upstream ethylene components and its C-terminus could be responsible for ethylene signal output. EIN2 is an integral membrane protein and its N-terminus is similar to the NRAMP family metal transporters (Alonso *et al.*, 1999). However, unlike other NRAMP-like proteins in *Arabidopsis*, the metal transport activity of EIN2 could not be demonstrated and the involvement of a NRAMP protein in the MAPK cascade has not been reported in any known signalling pathway.

It has been demonstrated that transcription factors including the EIN3 and EIN3-Like (EIL) proteins are involved in amplifying the ethylene signal at the transcriptional level (Chao, *et al.*, 1997). The loss-of-function mutants of EIN3 are ethylene insensitive, whereas over-expression of EIN3 activates the ethylene response constitutively, which suggests that the ethylene signalling is positively regulated by EIN3. Ein3 Binding Factor 1 and 2 (EBF1/2) have been identified to be responsible for mediating the ubiquitin degradation of EIN3 as part of the ethylene signalling mechanism (Guo and Ecker, 2003). More recently, it has been shown that an exoribonuclease XRN4 (AKA EIN5) could regulate the stability of EBF1/2 mRNA, possibly as a feedback loop of the ethylene signalling network (Olmedo *et al.*, 2006; Potuschak *et al.*, 2006). In addition, it has also been shown that the EIN3 protein could bind to the promoter region of other transcription factors such as Ethylene Response Factor1 (ERF1) to form another transcription cascade to further amplify the ethylene signal (Solano *et al.*, 1998).

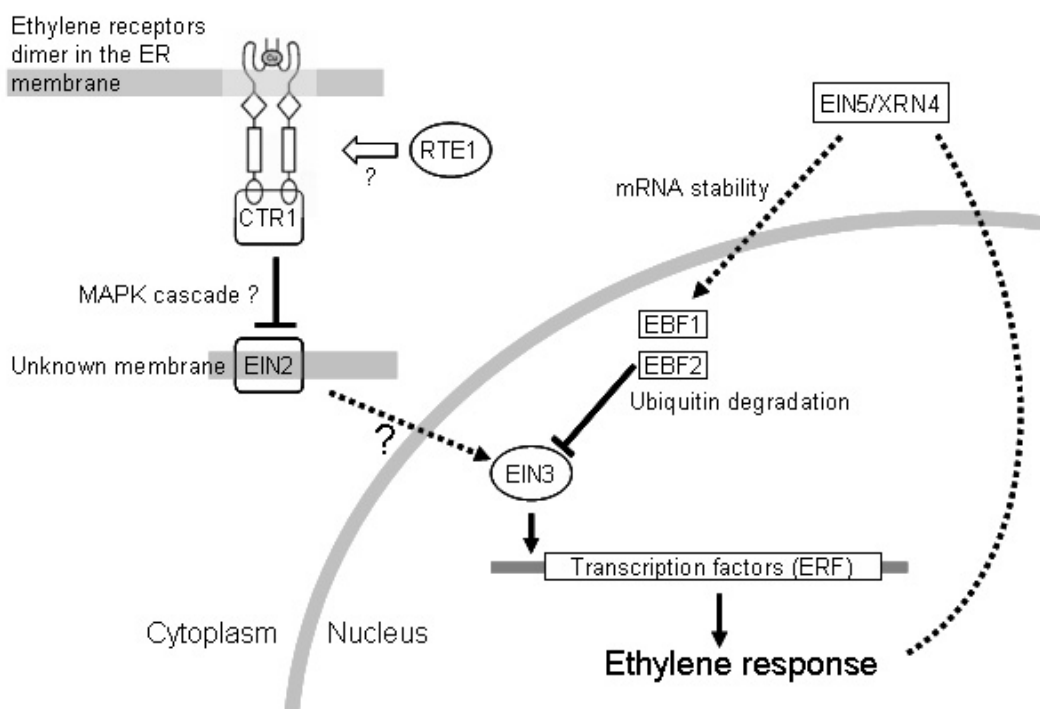

Figure 1.9: Linear ethylene signalling pathway in *Arabidopsis*

Ethylene binds to the receptors in the ER membrane possibly mediated by a copper co-factor and somehow requires an unknown protein RTE1 (Reverse to Ethylene Sensitivity1). The receptors directly interact with the Raf-like MAPKKK CTR1, which serves as a negative regulator of the ethylene signalling. A MAPK cascade could be involved to pass the signal down to EIN2, a putative membrane-associated NRAMP-like metal transporter. The ethylene signal is then transmitted into the nucleus to the transcription factors like EIN3 and ERFs. The EIN3 protein is subjected to ubiquitin degradation mediated by EBF1 and 2 (EIN3 Binding Factor), which act as the ubiquitin E3 ligases. A feedback loop is formed by EIN5 (XRN4) controlling the turn-over of the EBF mRNA, which in turn affects the stability of EIN3 (Modified from Olmedo *et al.*, 2006).

1.3 Ethylene Signalling in Tomato

1.3.1 Fruit ripening

Fruit ripening has been extensively studied because it is unique to plant biology and contributes an important part to the human diet. Fruits can be classified as either dry or fleshy. The *Arabidopsis* fruit (silique) falls into the dry fruit type category and releases the seeds in a process similar to senescence and abscission. On the other hand, the ripening process in the fleshy fruits such as tomato includes physiological, biochemical, and structural changes in order to attract seed-dispersing organisms. The fleshy fruits are divided into two classes: climacteric and non-climacteric according to the presence or absence of the increased respiration rate and the concomitant burst of ethylene production at the onset of ripening. Although the specific ripening process varies among fleshy fruit species, the ripening changes in climacteric fruits generally include: (1) increase of respiration rate and ethylene synthesis (2) colour changes (3) changes in flavour and nutritional content and (4) changes in texture (Seymour *et al.*, 1993).

Common climacteric fruits include tomato, apple and banana, which require ethylene for ripening, whereas non-climacteric fruits such as strawberry, orange and lemon do not exhibit a sudden burst of ethylene production, but a gradual decline in ethylene biosynthesis, a pattern similar to their respiration during ripening (Seymour *et al.*, 1993). It has been shown that ethylene biosynthesis occurs by the same pathway during ripening, senescence, in response to wounding, *etc* (see section 1.1.2 for details). As the non-climacteric fruits can still produce and respond to ethylene, two systems for

ethylene biosynthesis have been proposed (McMurchie *et al.*, 1972). The system I is ethylene auto-inhibitory and is responsible for the basal ethylene production in both climacteric and non-climacteric fruits, whereas the system II is unique to climacteric fruits and is believed to be auto-catalytic (reviewed in Alexander and Grierson, 2002). The role of the respiratory climacteric in fruit ripening is unclear as non-climacteric fruits can ripen without any increase in respiration and the molecular distinction between climacteric and non-climacteric fruits are poorly understood. However, ethylene is believed to be a key co-ordinator of the ripening process in climacteric fruit species, as preventing its production by chemical or genetic means inhibits ripening.

In general, colour change of the fruit is associated with ripening, which is attributed to the degradation of chlorophyll and the synthesis of new pigments in either plastids or vacuoles. In the case of tomato, the concentration of chlorophyll, which is associated with the thylakoid membrane in the chloroplast, peaks at the early stage of fruit growth. When ripening occurs, ethylene production and respiration start to rise and the chloroplasts begin to turn into chromoplasts. The chlorophyll is replaced firstly by β -carotene and eventually by lycopene, which produces the red-orange external colour of a tomato (reviewed in Grierson and Kader 1986). Mutations or genetic manipulations of the pigment biosynthesis genes usually result in fruits with altered colour. For example, the tomato mutant *yellow flesh* is caused by the loss-of-function (LOF) phytoene synthase gene *PSY* (*GTOM5*), whereas the failure to accumulate *trans*-lycopene in the tomato mutant *tangerine* is caused by LOF of the carotenoid

isomerase gene *CRTISO* (Fray and Grierson, 1993; Isaacson *et al.*, 2003).

The change of flavour in the ripening process is as important as the colour changes in term of attracting or deterring herbivores in a way to favour seed dispersal. Flavour change depends on a complex interaction of sugars, organic acids, phenolics and volatile compounds. In a classic ripening event, the acid content decreases due to the break down of the malic acid, which is a major substrate for respiration. The activity of amylase and starch phosphorylase increases during ripening and the starch is then converted to glucose, fructose or sucrose (Seymour *et al.*, 1993). The co-ordination of these processes results in the increase of sweetness in the ripened fruit, while the volatiles making up for the aroma complementing the taste to generate the unique flavour of the whole fruit. Several hundred flavour volatile compounds have been found, but often, a small number contributed the key “flavour notes”.

Fruit softening resulting in the enzymatic degradation of the cell wall is one of the major attributes of the ripening fruit. Polygalacturonase (PG) is one of the key enzymes regulating the texture changes during fruit ripening by depolymerising pectin, which is a major type of cell wall polysaccharide. PG is highly expressed in ripening fruit and it is the first ripening-related cDNA (pTOM series) to be sequenced from a library enriched in ripening tomato fruit mRNA (Grierson *et al.*, 1986). Other cell wall hydrolases such as pectinesterase, cellulase and galactosidase are also required to act synergistically with polygalacturonase to disassemble pectin during fruit ripening. As these cell wall

degrading enzymes are key players responsible for the texture changes during fruit ripening, they are also potential targets of genetic manipulation for crop improvements (Hamilton *et al.*, 1995).

1.3.2 Ethylene mutants affecting tomato fruit ripening

The model plant *Arabidopsis* has provided many insights into the molecular basis of fruit formation and development. On the other hand, tomato (*Solanum lycopersicum*) is a climacteric freshly fruit species, in which the ripening process is coordinated by the sudden burst of ethylene production. Therefore, tomato is a favourite system for studying ethylene signalling and biosynthesis, particularly in areas involving fruit ripening (Grierson *et al.*, 1981; Gray *et al.*, 1992; Fray and Grierson, 1993; Klee, 2004).

The tomato *never-ripe* (*nr*) mutant, which is characterized by the delay or incomplete ripening and the yellow-greenish colour of the fruit, results from a dominant gain-of-function missense mutation in the tomato ethylene receptor NR. The *nr* mutant plants display ethylene insensitivity throughout the developmental stages and it has been shown that NEVER-RIPE is a homologue of the *Arabidopsis* sub-family I ethylene receptor ERS1 (Wilkinson *et al.*, 1995; Yen *et al.*, 1995). The antisense inhibition of the mutated *NR* gene restored normal fruit ripening of *nr*, which is in agreement with the *Arabidopsis* model that ethylene signalling is negatively regulated by the receptors (Hackett *et al.*, 2000).

The gene responsible for the tomato fruit ripening mutant *green-ripe* (allelic to *never-ripe2*), has been recently cloned and shows sequence homology to the *REVERSE TO ETHYLENE SENSITIVITY1 (RTE1)* in *Arabidopsis* (Barry and Giovanonni, 2006). It has been suggested that the mutant *gr* was caused by the ectopic expression of *GR* and the mutant phenotypes could be mimicked by expressing the *GR* cDNA using a CaMV 35S promoter in wild-type tomato. This complements the model of RTE1 action in *Arabidopsis* that loss-of-function of *RTE1* results in increased sensitivity to ethylene (Resnick *et al.*, 2006), whilst over- or ectopic expression of *RTE1* causes reduced ethylene sensitivity.

1.3.3 Tomato ethylene receptors and CTRs

In tomato, a family of six ethylene receptors (LeETR1 to LeETR6; LeETR3 is named NR for historical reasons) has been identified (Willkinson *et al.*, 1995; Zhou *et al.*, 1996; Lashbrook *et al.*, 1998; Tieman and Klee, 1999). Like the *Arabidopsis* receptors, the tomato ethylene receptors are also divided into two subfamilies based on the conserved motifs found in the histidine kinase domain (Figure 1.10). Each tomato receptor is expressed in different temporal and spatial patterns dependent on developmental stages and external stimuli (reviewed in Klee, 2002). For example, LeETR1 and LeETR2 are constitutively expressed in all tissues; the expression of NR (LeETR3) in fruit is regulated developmentally and the ethylene receptor LeETR4, 5 and 6 are more abundant in reproductive than vegetative tissues.

Several tomato *CTR1*-like genes (*LeCTR1* to *LeCTR4* plus a splice variant of *CTR4*) have been reported to act genetically downstream of the ethylene receptors (Lin *et al.*, 1998; Leclercq *et al.*, 2001; Adams-Philips *et al.*, 2004). Among all the identified tomato CTR-like proteins, CTR1, CTR3 and CTR4 are more similar to the *Arabidopsis* CTR1 and they are capable of complementing the *Arabidopsis* CTR1 loss-of-function mutant in different degrees (Leclercq *et al.*, 2003; Adams-Philips *et al.*, 2004). It has been suggested that the tomato CTR2 might be a homologue of Enhanced Disease Response1 (EDR1) in *Arabidopsis* (Frye and Innes, 1998). EDR1 has been shown to be involved in stress and pathogen responses (Frye *et al.*, 2001). Additionally, *edr1-1* mutant also develops an enhanced ethylene response phenotype (Tang and Innes, 2002).

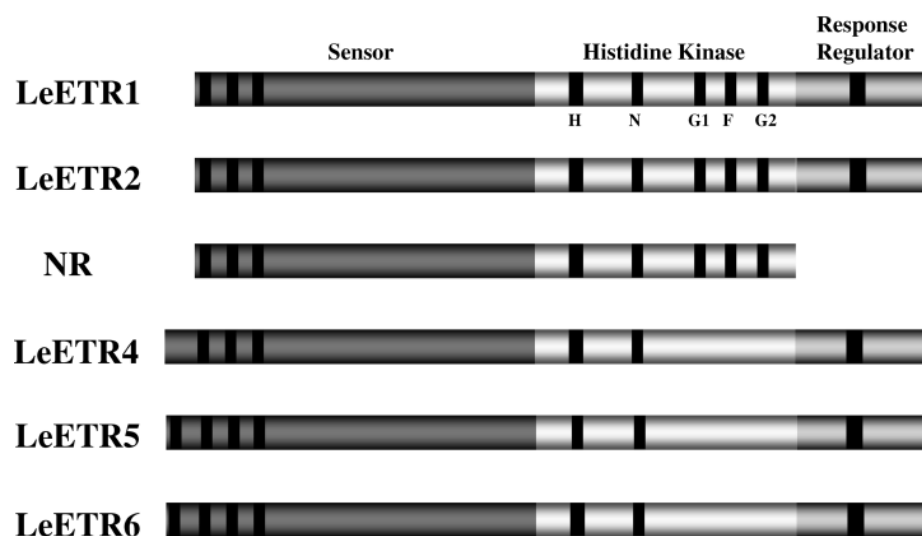

Figure 1.10: Tomato ethylene receptors

The tomato subfamily I ethylene receptors (ETR1, ETR2 and NR) have all the conserved motifs (black capital letters below the bar) in the His kinase domain. NR is the only receptor without the receiver domain (AKA response regulator). There is an extra putative membrane spanning domain (black bar in front of the three transmembrane domains) in ETR5 and ETR6 similar to those of the *Arabidopsis* ethylene receptor ETR4, 5 and 6 (Tieman and Klee, 1999).

Interestingly, there are several similarities between the *Arabidopsis* EDR1 and CTR1. Both *edr1-1* and *ctr1-1* are loss-of-function mutants of a MAPKK kinase. The LOF mutant of *EDR1* de-represses the defence response pathway as LOF of *CTR1* de-represses the ethylene signalling pathway, which suggests they are both negative regulators in their signalling network (Frye *et al.*, 2001). The dark grown seedling of *edr1-1* mutant displays normal ethylene sensitivity but the 6 week-old *edr1-1* plant grown in short-day condition has enhanced ethylene induced senescence when a high concentration (100 ppm) of exogenous ethylene is applied (Tang and Innes, 2002). In addition, the strong ethylene insensitive mutant allele *ein2* can suppress the enhanced ethylene-induced senescence of *edr1-1* just like it suppresses the *ctr1-1* mutant phenotype (Alonso *et al.*, 1999; Tang *et al.*, 2005). However, how ethylene affects the signal output of EDR1, which is a signalling component of the defence response, and how these two signalling pathways interact remain largely unknown.

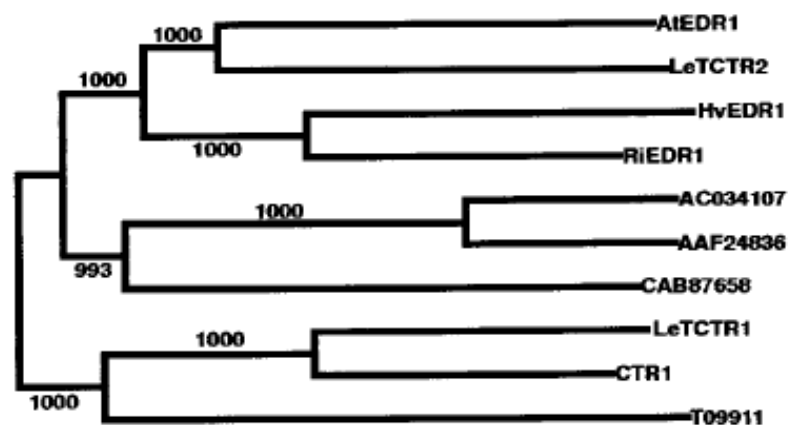

Figure 1.11: Phylogenetic tree of CTR-like proteins

LeCTR1 is closer to the *Arabidopsis* CTR1; LeCTR2 is more related to the *Arabidopsis* EDR1 in terms of the amino acid sequence conservation (Frye *et al.*, 2001).

1.3.4 LeCTR2 and the IntCR clones

In the *Arabidopsis* ethylene signalling model, the sub-family I ethylene receptors (ETR1 and ERS1) associate with the Raf-like kinase CTR1 and possibly form a receptor-CTR complex at the ER membrane (Gao *et al.*, 2003). In the case of tomato, several tomato CTR1-like proteins could also associate with the ethylene receptors in the yeast two-hybrid assay (Lin and Grierson, unpublished data). It has been shown that one of these CTR1-like proteins, LeCTR2 could interact specifically with LeETR1 and LeETR2 in the yeast two-hybrid assay but showed no interaction with NR (LeETR3), which is a receptor lacking the receiver domain (Lin and Grierson, unpublished data). The *in vitro* kinase activity of LeCTR2 has also been tested and shows striking similarity to that of the *Arabidopsis* and tomato CTR1. More importantly, transgenic tomatoes with an altered expression level of LeCTR2 displayed ethylene related phenotypes without affecting the endogenous ethylene biosynthesis (Lin and Grierson, unpublished data). Those transgenic tomato plants have enhanced production of side shoots and leaf epinasty, which are typical ethylene over-production phenotypes. Collectively, these findings indicated a possible involvement of LeCTR2 in the tomato ethylene signalling.

In an attempt to identify tomato ethylene signalling components, yeast two-hybrid experiments had been carried out to screen a tomato fruit cDNA library using the amino-terminus of LeCTR2 as bait and several novel IntCR (Interacting with CTR2) proteins were identified (Lin *et al.*, 2003). Based on the previous finding that LeCTR2

could associate with the ethylene receptor LeETR1, the IntCR proteins were subsequently tested for their ability to associate with the tomato ethylene receptor ETR1. Interestingly, three IntCR proteins were able to associate with the ethylene receptor LeETR1 in the yeast two-hybrid assay (Table 1.2). The IntCR clone 22 (IntCR22) is similar to the *Arabidopsis* UDP-glycosyltransferases (UGT); IntCR242 has similarity to the *Arabidopsis* PRL1-Interacting Factor L (At1g15730); IntCR266 belongs to the family of FtSH proteinase.

Table 1.2: The IntCR clones

IntCR Clones	Homolog	Possible Function
IntCR22	UDP-glycosyltransferase	Cytokinin and flavonoid metabolism
IntCR242	PRL1 Interacting Factor L	PRL1 is involved in sugar sensing
IntCR266	FtSH Proteinase	Repair damaged photosystem II

The homologue and function were predicted according to the BLAST search results using the DNA sequence of the IntCR clones as entry (Lin and Grierson, unpublished data).

IntCR Clone 22

From the BLAST search results, the IntCR22 clone matches the tomato EST TC176700, which is a putative UDP-glycosyltransferase (UGT). UGT catalyzes the transfer of a glycosyl moiety from the donor to its substrates, forming a glycosidic bond. Whereas the animal UGTs utilize UDP-glucuronic acid, the UGTs in the higher plants use UDP-glucose. A super-family of 107 UGTs has been found in the model plant *Arabidopsis*. A phylogenetic analysis of the entire *Arabidopsis* UGT family has recently

been completed and the *Arabidopsis* UGTs were divided into 14 subgroups (Bowles *et al.*, 2005). The deduced protein sequence of TC176700 (IntCR22) shows about 50% identity (70% similarity) to the *Arabidopsis* UGTs in the 73C subgroup. However, the substrates of the 73C UGTs have not yet been fully identified, except for 73C5 and 73C6, which could be involved in the cytokinin inactivation and flavonoid biosynthesis.

It has been reported that UGT73C5 could glycosylate the OH group of the N⁶ side-chain of *trans*-zeatin and dihydrozeatin (Hou *et al.*, 2004) and is also able to detoxify *Fusarium* mycotoxin deoxynivalenol by glycosylating the OH group of the C³ of deoxynivalenol (Popenberger *et al.*, 2003). On the other hand, UGT73C6, which also shares sequence homology to IntCR22, is involved in flavonol synthesis by catalyzing the transfer of glucose to the 7-OH position of kaempferol-3-O-rhamnoside and quercetin-3-O-rhamnoside (Jones *et al.*, 2003). The direct involvement of a UGT in ethylene signalling has not been reported so far. However, ethylene does affect and interfere with the signalling pathway of many plant growth regulators and also regulates their biosynthesis and metabolites (Chiwocha *et al.*, 2005). Therefore, IntCR22 might provide further insight into the ethylene signalling cross-talk with other phytohormones.

IntCR Clone 242

The cDNA sequence of IntCR242 matches the tomato EST TC181289, which is a 0.5 kb truncated cDNA fragment similar to the 3' end region of the *Arabidopsis* genes At1g15730 and At1g80480. At1g15730 has been previously identified in the yeast

two-hybrid screen as a protein that could interact with PLEIOTROPIC RESPONSE LOCUS1 (PRL1). It has been shown that PRL1 could associate with components of the *Arabidopsis* sugar sensing network (Bhalerao *et al.*, 1999). Loss-of-function mutant of PRL1 has a sugar hypersensitive phenotype, which results in the de-repression of glucose suppressed genes. Interestingly, the *prl1* mutant also showed enhanced sensitivity to several plant growth regulators including ethylene (Nemeth *et al.*, 1998). Additionally, it has been shown that the tomato PRL1-like protein could interact with IntCR242 in the yeast two-hybrid assay (Lin and Grierson, unpublished data).

It has long been hypothesized that there are links between ethylene and sugar sensing (Gibson *et al.*, 2001; Rolland *et al.*, 2002). For example, the *sugar-insensitive1* (*sis1*) and *glucose insensitive4* (*gin4*) mutants are allelic to the ethylene signalling mutant *ctr1*. The *ethylene over-production1* (*eto1*) mutant is resistant to the inhibitory effect of sugar during early seedling development, which can be phenocopied by applying exogenous ethylene to the wild-type *Arabidopsis* (Gibson, 2004). Conversely, the ethylene insensitive mutants and ethylene inhibitor treated *Arabidopsis* seedlings are hypersensitive to sugar. As the above examples demonstrate, sugar and ethylene signalling pathways can interact with each other, but little information is available about how and where this “cross-talk” actually takes place. Thus, IntCR242 became particularly interesting due to its unique ability to associate with components in both ethylene signalling (LeETR1 and CTR2) and sugar sensing (LePRL1) pathways.

IntCR Clone 266

The DNA sequence of IntCR266 matches the tomato EST TC115877, which encodes a truncated protein similar to the Filamentation Temperature Sensitive H (FtSH) proteins in *Arabidopsis*. The FtSH proteins were initially identified in *E. coli*, in which they are metallo-proteinases involved in protein quality controls (reviewed in Beyer, 1997). The N-terminus of the FtSH protein normally contains two transmembrane domains to anchor the proteinase to a specific membrane; its C-terminal domain has a zinc binding site, which could be involved in binding target substrates.

The FtSH proteins are conserved in photosynthetic organisms like cyanobacterium and higher plants (reviewed in Adam *et al.*, 2004; Yu *et al.*, 2004). There are 12 FtSH-like proteins in *Arabidopsis* and most of them are located in plastids. The AtFtSH5 (VAR1) and AtFtSH2 (VAR2) have been studied in detail because a loss-of-function mutant of either one resulted in a plant with leaf variegation (VAR) phenotypes (Sakamoto *et al.*, 2002; Sakamoto *et al.*, 2003). It has been demonstrated that FtSHs are responsible for the degradation of the photo-damaged photosynthetic system II (PSII) and the misfolded membrane proteins, which also suggested that the leaf variegation phenotypes of the AtFtSH5 and AtFtSH2 LOF mutant are possibly due to hypersensitivity to light stress (Nixon *et al.*, 2004). Interestingly, besides the involvements of FtSH in the photo-damage related light stress, a tobacco FtSH-like protein D9 was found to be involved in the resistance to tobacco mosaic virus infection (Seo *et al.*, 2000).

1.4 Objectives

The research presented in this thesis is a natural progression of the studies involving characterization of LeCTR2, a putative CTR1-like kinase that interacts with the ethylene receptors in the yeast two-hybrid experiments (Lin, PhD thesis, University of Nottingham, 1999). Three novel proteins had been identified in a yeast two-hybrid screen that could associate with both LeCTR2 and the ethylene receptor LeETR1 (Lin and Grierson, unpublished data). Therefore, it was expected that analyzing these novel proteins would provide further information about the function of LeCTR2.

The objective of this study was first to obtain the full-length coding sequences of IntCRs, which would be used to generate transgenic plants for determination of their physiological functions. It was proposed also to express recombinant GFP fusion proteins and to identify the sub-cellular localization of IntCR by fluorescence microscopy. Additionally, this study included part of a collaboration with Dr. Francisco Flores to synthesize and purify the IntCR proteins in order to study their *in vitro* substrates. In the later stage of the research, a transient protein expression system, which has been developed for the localization studies of the IntCR proteins, was applied to determine the localization of the tomato ethylene signalling components. Furthermore, the fluorescence proteins in the transient expression vectors have been modified to be used for Forster resonance energy transfer (FRET) and bio-molecular fluorescence complementation (BiFC) experiments, through which the *in planta* protein-protein interaction between the ethylene signalling components was investigated.

CHAPTER 2: MATERIALS AND METHODS

2.1 Chemicals

All laboratory chemicals were purchased from Sigma (Sigma-Aldrich Co. Ltd., UK) and Fisher (Fisher Co. Ltd., UK), unless otherwise mentioned. Microbiological media were obtained from Oxoid (UK).

2.2 Plant Materials and Growth Conditions

Wild type tomato (*Solanum lycopersicum* Mill. cv. Ailsa Craig) seeds used in this experiment were obtained from a homozygous line maintained at the Plant Sciences Division (School of Biosciences, the University of Nottingham). The seeds of *Arabidopsis* including mutants and the ecotype Columbia were obtained from the Nottingham Arabidopsis Stock Centre (NASC) unless otherwise mentioned. The tobacco wild type seeds (*Nicotiana tabacum* var. *Petit Havana*) were kindly provided by Dr. Rupert Fray (Plant Sciences Division, the University of Nottingham). Unless specific conditions are stated, the *Arabidopsis*, tomato and tobacco plants were grown in the following compost mix: 6 parts of Levington M4, 6 parts of John Innes No.3, 1 part of vermiculite and 1 part of perlite. For growing *Arabidopsis*, 20 mg/l Intercept (Scotts, UK) insecticide was applied to the compost. The glasshouse for maintaining tomato and tobacco plants was kept at minimum 16 h day regime at about 22-26°C. The greenhouse for growing *Arabidopsis* was maintained with 22 h photoperiod at about 21-23°C.

2.3 Plant Transformations

2.3.1 Tomato transformation

All procedures were performed in a sterilized environment and all Petri dishes were sealed with parafilm before moving to the tissue culture room. Tomato seeds were surface sterilized prior to germination by soaking for 5 min in 75% (v/v) ethanol, 20 min in saturated tri-sodium orthophosphate solution and 10 min in 50% (v/v) bleach (locally purchased from Tesco, UK). This was followed by four washes with sterile distilled water (SDW) to remove the bleach solution. Seeds were germinated in sterilized pots containing autoclaved solid MS medium (4.2 g/l MS salt, 3% (w/v) sucrose, 1 ml/l R3 vitamin (1 g/l thiamine, 0.5 g/l nicotinic acid, 0.5 g/l pyridoxine) and 1% (w/v) agar; pH 5.5-5.8 by KOH) in the growth rooms (16 h of light at 25 °C and 8 h of darkness at 18 °C). Cotyledons of the two-week old tomato seedlings were excised in a flow hood and rinsed briefly in liquid MS24D medium (liquid MS medium supplemented with 0.1 mg/l kinetin and 0.2 mg/l 2-4D) before placing at high density on Petri dishes with solid M1 medium (MS supplemented with 1.75 mg/l zeatin and 0.87 mg/l IAA). The Petri dishes were then sealed with parafilm and incubated overnight under low light conditions (covered by a layer of muslin) in the inverted position to prevent water condensation.

On the next day, a 10 ml overnight liquid culture of *Agrobacterium* (LBA4404: pAL4404) carrying the appropriate construct was spun down (3,000 x g, 10 min, RT) and suspended in 100 ml of liquid MS medium to about 0.1-0.2 OD⁶⁰⁰ in a sterilized

flow hood. The overnight cultured cotyledons were then transferred from the M1 medium to the *Agrobacterium* suspension and incubated for 15 min with occasional shakings. The cotyledons were then briefly rinsed in sterilized liquid MS24D medium to remove the excessive *Agrobacterium*. The cotyledons were placed back on to the same Petri dishes with M1 medium, covered with muslin and co-incubated with *Agrobacterium* for two days.

The infected cotyledons were then transferred to plates with M13 medium (M1 supplemented with 75 mg/l kanamycin and 200 mg/l augmentin) at a density of 15 cotyledons per Petri dish (Sterlin, 9 cm). Plates were covered with muslin and incubated in the growth room in the inversed position to induce callus formation. The muslin cover was removed after the first week incubation and from this point the explants were sub-cultured to freshly prepared M13 media every 2 weeks to maintain the antibiotic selection pressure.

The explants developing calluses of 1 to 2 mm in diameter were transferred to sterilized plastic pots containing shoot inducing medium M4 (M1 with 50 mg/l kanamycin and 200 mg/l augmentin). Once the shoots were regenerated from the calluses, they were excised and placed into pots with root inducing medium M16 (MS medium with 50 mg/l kanamycin and 200 mg/l augmentin). When a branching root system had been established, the whole plant was transferred to compost in a 9 cm pot and covered with a transparent plastic bag to maintain humidity. The small plants were then allowed to

recover for one to two weeks before removing the plastic bag cover. The transgenic tomato plants were re-potted and maintained in the greenhouse under general conditions as previously described (Section 2.2).

2.3.2 Tobacco transformation

The surface sterilized tobacco seeds were first germinated and grown in sterilized plastic pots with MS medium for 4-5 weeks. The leaves were cut into 1 cm diameter leaf disks in a sterilized flow hood and dipped into the *Agrobacterium* suspension (as prepared in section 2.3.1). The leaf disks were then blotted on an autoclaved filter paper (Whatman, UK) to remove the excessive *Agrobacterium* before incubating overnight on Petri dishes containing callus inducing medium (MS with 1 mg/l BA and 0.1mg/l NAA). The leaf disks were transferred to fresh callus inducing medium (MS with 1 mg/l BA, 0.1mg/l NAA, 100 mg/l kanamycin and 200 mg/l augmentin) and sub-cultured to freshly prepared medium every two weeks. The shoots regenerated from the calluses were transferred to root inducing medium (MS with 100 mg/l kanamycin) and the following procedures were the same as for the tomato transformation (see section 2.3.1 for details).

2.3.3 *Arabidopsis* transformation

The floral dip method (Clough and Bent, 1998) was used to transform *Arabidopsis* using *Agrobacterium tumefaciens* C58C1 (pCH32). 100 ml of the *Agrobacterium*

overnight culture was spun down (3,000 x g, RT) and suspended in 200-300 ml 5% (w/v) sucrose solution. Silwet-L77 was added to the *Agrobacterium* solution to a final concentration of 0.05% (v/v) prior to dipping. The aerial parts of flowering *Arabidopsis* plants grown in 9 cm pots were dipped into the *Agrobacterium* solution for 15 s with gentle agitation. The dipped plants were covered with folded plastic sleeves for 24 h to maintain humidity. After transformation, plants were watered and grown normally for 3-4 weeks; the seeds of the transformed plants were then harvested and screened on MS media with appropriate antibiotics according to the selection marker present in the transgene construct. The collected seeds were first surface sterilized by soaking in 50% (v/v) bleach with a drop of Triton X-100 for 5 min and washed 5 times with SDW. This was followed by suspending the seeds in autoclaved 0.7% (w/v) agar solution (40 °C) and pouring them onto Petri dishes with solid MS medium (1% (w/v) agar) with suitable antibiotics. Petri dishes were dried for 30 min in the flow hood and sealed with parafilm. The dishes were then kept in the cold room (4 °C) without light for 2-3 days before being transferred to the tissue culture room (18 h photoperiod, 23-25 °C). After 2 to 3 weeks, *Arabidopsis* seedlings that developed dark green true leaves and an extending root system were transferred to compost in the 9 cm pots and grown in the glasshouse under general conditions as previously mentioned (Section 2.2).

2.4 Genomic DNA Extraction

2.4.1 MiniPrep

Genomic DNA extractions from tomato, tobacco or *Arabidopsis* tissues were carried out

by using the GenElute™ Plant Genomic DNA Miniprep Kit (Sigma, G2N70), according to the manual with slight modifications. 300 mg of tissue was used, instead of 100 mg suggested by the manufacturer. The DNA was eluted with 100 µl SDW instead of 200 µl Elution Buffer.

2.4.2 Phenol-chloroform method

For large scale genomic DNA preparation, approximately 2-5 g of leaf tissue was harvested in a 50 ml centrifuge tube and frozen in liquid nitrogen immediately. The tissue was then transferred to a pre-cooled mortar and was ground to fine powder under liquid nitrogen. The tissue powder was transferred to a 50 ml tube with 10 ml of DNA extraction buffer (42% (w/v) urea, 0.31 M NaCl, 50 mM Tris-HCl pH 8.0, 20 mM EDTA pH 8.0 and 1% (w/v) sodium sarcosine). After vigorous vortexing, the samples were incubated in a 65°C water bath for 10 min. 10 ml of phenol-chloroform solution (50% (v/v) phenol, 48% (v/v) chloroform and 2% (v/v) isoamyl alcohol; saturated with TE pH 8.0) was added to the mixture. This was followed by vortexing and centrifugation (12,000 rpm, 10 min). The upper phase was transferred to 50 ml tubes with 5 ml of chloroform (with 2% (v/v) isoamyl alcohol) and mixed thoroughly by vortex. After centrifugation (12,000 rpm, 5 min) the upper phase was transferred to 50 ml tubes with an equal volume of isopropanol (propan-2-ol), mixed thoroughly by inversion and then kept at -20°C for at least 60 min. The tubes were then centrifuged (11,000 rpm, 4°C, 20 min) to pellet the DNA. The supernatants were decanted and the pellets were washed in 10 ml of 75% (v/v) ethanol. The DNA pellet was dissolved in

0.5 ml of TE buffer and transferred to an autoclaved 1.5 ml centrifuge tube. This was followed by the addition of 1 μ l of RNase A (10 mg/ml, Fermentas) and incubation in an oven at 37 °C for 1 h. The RNase was then removed by one phenol-chloroform and one chloroform extraction. After the removal of RNA, an equal volume of cold isopropanol was then added to the tube followed by 1 h incubation in -20 °C. Finally, the genomic DNA was pelleted by centrifugation (14,000 rpm, 15 min) and suspended in 50 μ l water or TE buffer.

2.5 RNA Extraction

2.5.1 MiniPrep

RNA extractions were carried out using the RNeasy Mini Kit (QIAGEN), according to the manufacturer's instruction with slight modifications. 150 mg of leaf tissue was ground to fine powder under liquid nitrogen in a 2 ml eppendorf tube and 500 μ l of extraction buffer RLT was added. Tubes were then vortexed vigorously and incubated in a 60°C heat block for 5 min. The mixtures were then loaded onto the mini-prep columns and the following procedures were performed according to the manufacturer's protocol.

2.5.2 Phenol-chloroform method

5 g of frozen tomato fruit tissue was first ground into fine powder with a coffee grinder (Braun). This was followed by grinding in a pre-chilled mortar under liquid nitrogen.

The tissue powder was then transferred into a 50 ml centrifuge tube with 15 ml RNA extraction buffer (1% (w/v) triisopropyl naphthalene sulphonic acid, 6% (w/v) 4-amino salicylic acid, 5% (w/v) phenol mixture (500 g phenol, 70 ml *meta*-cresol and 0.5 g of 8-hydroxyquinoline, and 150 ml of SDW)). Samples were left on the bench to thaw with occasional vortexing. An equal volume of phenol-chloroform was subsequently added and the tubes were mixed by vigorous shaking. The aqueous phase and the organic phase were separated by centrifugation (10,000 rpm, 10 min). The nucleic acids containing upper aqueous layer was then transferred to a new 50 ml tube and extracted again with an equal volume of phenol-chloroform. This was followed by a 5 ml chloroform (with 2% (v/v) isoamyl alcohol) extraction to remove the remaining phenol. After partition as before, the total nucleic acids in the aqueous phase were precipitated by adding an equal volume of pre-chilled isopropanol. The tubes were then incubated at -20°C for at least 1 hour and were centrifuged for 20 min (10,000 rpm, 4°C) to pellet the total nucleic acids. The pellet was first washed with chilled 75% (v/v) ethanol and suspended in 1 ml of RNase-free SDW. The insoluble debris was removed by a snap spin. The RNA was subsequently precipitated with an equal volume of 4 M LiCl solution and kept on ice for 1 h. After centrifugation (14,000 rpm, 4°C), the RNA pellet was washed with 500 μl of 75% (v/v) ethanol, dried under vacuum and suspended in 500 μl RNase-free water. The LiCl precipitation was repeated once to remove the genomic DNA. The final RNA pellet was suspended in 100 μl of RNase-free SDW. RNA was quantified by using the NanoDrop spectrometer and stored at -70°C .

2.6 GEL Electrophoresis

2.6.1 Non-denatured agarose gel

Agarose (Bioline) was melted in 1 x TAE buffer (4.84 g/l Trizma Base, 1.142 ml/l acetic acid and 2 ml/l 0.5 M EDTA pH8.0) in a microwave oven and cooled down to 60°C before ethidium bromide (EtBr) was added to a final concentration of 0.05-0.1 µg/ml. A casting tray was sealed with masking tape at both ends and the agarose solution was poured into the casting tray with the comb inserted. The gel was then left on the bench to set for 15-30 min and transferred to an electrophoresis tank with 1 x TAE buffer. After loading the samples and the molecular size marker, DNA was electrophoresed at 100 V for an appropriate time. The gel was subsequently exposed to UV light (Transilluminator, Syngene) and photographed by UVP Imagestore 5000.

2.6.2 DNA extraction from agarose gel

Gel extraction was carried out by using the QIAquick Gel Extraction Kit or MiniElute Kit (QIAGEN) according to the manufacturer's instruction. For rapid purification of DNA in a agarose gel for a second round PCR, a spin column was assembled by placing a 0.5 ml tube inside a 1.5 ml tube and the bottom of the 0.5 ml tube was punctured with a needle. A small piece of wet filter paper was placed inside the 0.5 ml tube to cover the hole. The agarose gel slice containing the desired DNA band was then placed into the 0.5 ml tube and was snap frozen in liquid nitrogen before centrifugation (14,000 rpm, RT, 2 min). The flow through liquid was collected into a new tube and used for PCR.

2.7 Polymerase Chain Reaction

2.7.1 General PCR protocol for *Taq*

1 µl of forward primer (10 µM)	Lid: 100 °C
1 µl of reverse primer (10 µM)	1: 95 °C 5 min (initial denaturation)
1 µl of dNTP (10 mM)	2: 94 °C 30 sec (denaturation)
1.5 µl of MgCl ₂ (50 mM)	3: 56 °C 30 sec (annealing)
5 µl of 10x PCR Buffer	4: 72 °C 1 min (extension)
1 µl of DNA Template	5: go to 2 for 34 times
40 µl of SDW	6: 72 °C 5 min (final extension)
0.5 µl of <i>Taq</i> DNA polymerase (5 U/µl)	7: hold at 20 °C

The above PCR mixture was kept on ice block (ISOfreeze, Alpha Laboratory Supply) before being placed into the PCR machine. The annealing temperature was optimized for each of the primer pairs. The extension time was directly proportional to the length of the PCR product (1 min for 2 kb). The PCR program used is shown as above.

2.7.2 General PCR protocol for Accuzyme

2 µl of forward primer (10 µM)	Lid: 100 °C
2 µl of reverse primer (10 µM)	1: 94 °C 5 min (first denaturation)
0.5 µl of dNTP (100 mM)	2: 94 °C 30 sec (denaturation)
5 µl of 10x Buffer	3: 52 °C 30 sec (annealing)
25 µl 2x Polymate additive	4: 72 °C 1 min (extension)
1 µl of DNA Template	5: go to 2 for 29 times
15 µl of SDW	6: 72 °C 5 min (final extension)
0.5 µl of <i>Accuzyme</i> (3 U/µl)	7: hold at 10 °C

Accuzyme is a proof-reading DNA polymerase and was used to amplify cDNA or in other processes where high fidelity was required. The 2 x Polymate Additive is a PCR reagent that increases the PCR specificity when high GC content DNA templates were used. The time for the extension step was directly proportional to the length of the PCR product (1 min for 0.5- 0.75 kb).

2.7.3 General PCR protocol for Phusion

2.5 µl of forward primer (10 µM)	1: 98 °C 30 sec (first denaturation)
2.5 µl of reverse primer (10 µM)	2: 98 °C 10 sec (denaturation)
1.5 µl of dNTP (100 mM)	3: 58 °C 20 sec (annealing)
10 µl of 5x Buffer	4: 72 °C 30 sec (extension)
1 µl of DNA Template	5: go to 2 for 29 times
33 µl of SDW	6: 72 °C 5 min (final extension)
0.5 µl of Phusion (2.5 U/µl)	7: hold at 10 °C

Phusion is a modified *Pfu* DNA polymerase which has an artificial DNA binding domain fused to the DNA polymerase domain. It has the highest temperature tolerance, the fastest processing rate (15 sec to 30 sec for 1 kb DNA) and the lowest error rate compared to other commercially available proof-reading DNA polymerases.

2.7.4 PCR from leaf extract

PCR from leaf extract was carried out for genotyping the transgenic plants by using the Extract and Amp Plant PCR Kit (Sigma) with the forward nptII PCR primer 5'-tggagaggctattcggctat-3' and reversed nptII primer 5'-cgctatgtcctgatagcgggt-3'.

2.8 Cloning DNA into Plasmid Vectors

2.8.1 Ligation

The vectors were either purchased or homemade (plasmids digested with desired restriction endonuclease and dephosphorylated with calf intestinal alkaline phosphatase). In a 10 µl ligation reaction, 50 ng of vector, an appropriate amount of DNA (3:1 insert to vector molar ratio), SDW, 2 µl of 5x ligation buffer and 1µl of T4 DNA ligase (3

U/ μ l) were mixed and incubated overnight in the cold room (4°C). In the case of the home made vectors, a ligation reaction without insert was performed as a negative control.

2.8.2 Gateway cloning

To generate PCR product for gateway cloning, an extra nucleotide sequence CACC was added to the forward PCR primer in front of the first ATG (CACC ATGNNNNNNN). The purified PCR product containing CACC in the 5' end was directionally cloned to the pEntr SD vector (Invitrogen) through TOPO isomerase reaction according to the manufacturer's protocol. As the efficiency of TOPO reaction decreases significantly when the size of the insert exceeds 3 kb, the pEntr 11A vector (Invitrogen) was used for cloning large PCR DNA fragments by restriction digestion and ligation. PCR products were also cloned into pDonor221 vector through the BP reaction (Invitrogen). The DNA fragment of interest was amplified in a two-step PCR approach. The first PCR was performed with gene specific primers (GSP) with an additional *attB* tag in the 5' end, the second round PCR was carried out with *attB* adaptor primers (Invitrogen), which recognize the tags of the GSP primers. The GSP forward PCR primer has extra "aaaaagcaggctnn" in the 5' end and the GSP reverse primer has extra "agaaagctgggtt" in the 5' end. The sequences of the *attB* adaptor forward and reverse primer are 5'-ggggacaagttgtacaaaaagcaggct-3' and 5'-ggggaccactttgtacaagaa agctgggt-3'. The final PCR product was then cloned into pDonor221 vector through the BP reaction. In a 0.2 ml tube, 0.5 μ l of pDonor221 (25 ng) was mixed with 1.5 μ l of the purified PCR

product (10-20 ng) and 0.5 μ l of BP clonase II was added. The tube was incubated in a PCR machine at 25 °C for no less than 3 hours before 0.5 μ l of proteinase K was added to inactivate the enzyme for 15 min at 37 °C. The 3 μ l BP reaction product was then used immediately for *E. coli* transformation and selected on solid LB medium supplemented with 50 mg/l kanamycin. The pDonor plasmid with the inserted DNA fragment after the BP reaction has two newly formed attL sites as those in the pEntr plasmid and is compatible with the Gateway cloning system. Once the DNA fragment was cloned into the pENTR or pDonor vectors, which contain attL sites, they were recombined to the pDestination vectors containing the attR sites through the LR reaction (Invitrogen). In a 0.5 ml PCR tube, 1 μ l (50 ng) of pEntr plasmid, 1 μ l (50 ng) of the pDestination vector, 0.5 μ l LR clonease II were mixed and incubated at 25 °C for two hours. 0.5 μ l of proteinase K was added to the LR reaction mix to remove the enzymes prior to *E. coli* transformation.

2.8.3 Preparation of competent *E. coli* cells

A single colony of *E. coli* (DH5 α , DB31 or TOP10) was picked from an overnight incubated LB plate into 5ml of Ψ Broth media (2% (w/v) Bacto Tryptone, 0.5% (w/v) yeast extract, 0.4% (w/v) MgSO₄, 10 mM KCl, pH 7.5 with KOH), and incubated overnight in a shaking incubator (250 rpm, 37°C). 1 ml of the overnight master culture was transferred to 100 ml of pre-warmed Ψ Broth media, incubated for 2-3 h until the OD₅₅₀ reached 0.48. The cells were then chilled in an ice-water bath for 15 min, and centrifuged down (5 min, 2500 rpm, 4°C). Afterwards all steps were carried out at 4 °C.

The cell pellet was gently suspended in 26 ml of chilled TBFI solution (100 mM RbCl, 50 mM MnCl₂, 30 mM KOAc, 10 mM CaCl₂, 15% (v/v) glycerol, pH 5.8 with 0.2 N acetic acid), and kept on ice for 15 min. The cell suspension was then centrifuged down (5 min, 2500 rpm, 4°C) and the pellet was suspended gently in 4 ml of chilled TFBII solution (10 mM MOPS buffer pH 7.0, 10 mM RbCl, 75 mM CaCl₂, 15% (v/v) glycerol). 50 µl of cells were dispensed into pre-chilled 1.5 ml tubes and frozen immediately in liquid nitrogen. The cells were stored at -70°C. The transformation efficiency of the competent cells was about 10⁷ cfu/µg using pUC19 DNA.

2.8.4 *E. coli* transformation

The *E. coli* competent cells were thawed on ice for no more than 15 min. 5 µl of the ligation reaction mixture was added to the cells. The tube was then incubated on ice for 10-15 min, heat shocked in a 42°C water bath for 60 to 90 sec, and immediately placed back on ice for 1 min. 300 µl of room temperature LB medium was then added to the cells. Tubes were incubated at 37°C for 1 h before being spread onto LB plates containing the appropriate antibiotics. The plates were incubated overnight in an inverted position in a 37°C oven to allow the transformed cells to form colonies.

2.8.5 Plasmid preparation

The small scale plasmid preparations were performed using QIAprep Spin Miniprep Kit (QIAGEN, Cat. 27104), following the manufacturer's instruction with slight

modifications. For high copy number plasmids, 10 ml of overnight culture was used. In the case of low copy number plasmids like the binary vectors and yeast vectors, 50 ml of overnight culture was used and the buffers used in the following steps were increased accordingly. The large scale plasmid preps (200 to 300 ml LB culture) were carried out by using the Maxi prep (anion exchange) column (Qiagen) following the manufacturer's protocol. The overnight culture was spun down by centrifugation of 2,000 x g for 15 min at 4 °C. The pellet was suspended in 20 ml buffer P1 and mixed by vigorous vortex before adding an equal volume of buffer P2. The tubes were mixed by gentle inversions and incubated at room temperature for 5 min. Chilled buffer P3 (20 ml) was added to the tube and followed by a 15 min incubation on ice. The cell debris was removed by two centrifugations at 12,000 rpm for 20-30 min at 4 °C. Between the centrifugations, the supernatant was filtered through a glass wool to further reduce the debris. The clear supernatant was subsequently transferred to a 50 ml tube with an equal volume of isopropanol. The plasmid DNA was then pelleted by centrifugation (10,000 rpm, 4 °C, 30 min) and suspended in 1 ml TE buffer and the remaining RNA was removed by digesting with 1 µl of RNase (37 °C, 30 min). The solution was then loaded onto the Maxi column (Qiagen) with buffer QBT. The following procedures were performed according to the manual. The *E. coli* glycerol stocks were prepared from 0.5 ml of the overnight liquid culture prior to the plasmid prep by adding an equal volume of 20% (v/v) glycerol. The glycerol stock was then snap frozen in liquid nitrogen and stored at -70 °C.

2.9 Southern Blot

2.9.1 Genomic DNA digestion

10 µg of genomic DNA was digested overnight with 10 U of an appropriate restriction enzyme (Fermentas) in a total volume of 100 µl. The effect of digestion was checked by running 5 µl of the digested DNA in a TAE agarose gel. The remaining DNA was then precipitated by adding 10 µl of sodium acetate (3 M, pH 5.2) and 300 µl of ethanol. The mixture was placed at -20°C for 30 min before centrifugation (14,000 rpm, 15 min). The pellet was first washed with 70% (v/v) ethanol and air dried before dissolving in 20 µl of TE buffer.

2.9.2 Electrophoresis and blotting

The digested genomic DNA samples and the molecular weight marker (Bioline) were loaded onto a 1% (w/v) TBE (10.8 g/l Tris; 5.5 g/l boric acid and 0.74 g/l EDTA) agarose gel. Two wells were left unloaded between the DNA marker and the first genomic DNA sample. The gel was electrophoresed overnight at 40 V in half strength TBE buffer. The UV photograph of the gel was then taken as a record. The corner of the gel near the marker loading site was cut as an indication of the position of the samples. To transfer the DNA to a membrane, the gel was first rinsed briefly in SDW and denatured for 40 min in solution I (1.5 M NaCl, 0.5 M NaOH) with gentle shaking. A depurination step (0.25 N HCl, 5-10 min) would be required before denaturation if the DNA fragments larger than 10k were to be transferred. The gel was then rinsed with

SDW and soaked in the neutralization solution for 40 min (1.5 M NaCl, 0.5 M Tris-Cl pH 7.0). The gel was then soaked in 10 x SSC buffer (20x SSC: 175 g/l NaCl, 88 g/l NaCit, pH 7.0) for 5 min. This was followed by transfer of the denatured DNA to a nylon membrane (GeneScreen, NEN Life Science). The upward capillary blotting was assembled as below using 10 x SSC as transfer buffer (Figure 2.1). The DNA was fixed to the membrane by UV crosslink (Stratalinker 2400, Stratagene) after the overnight blotting.

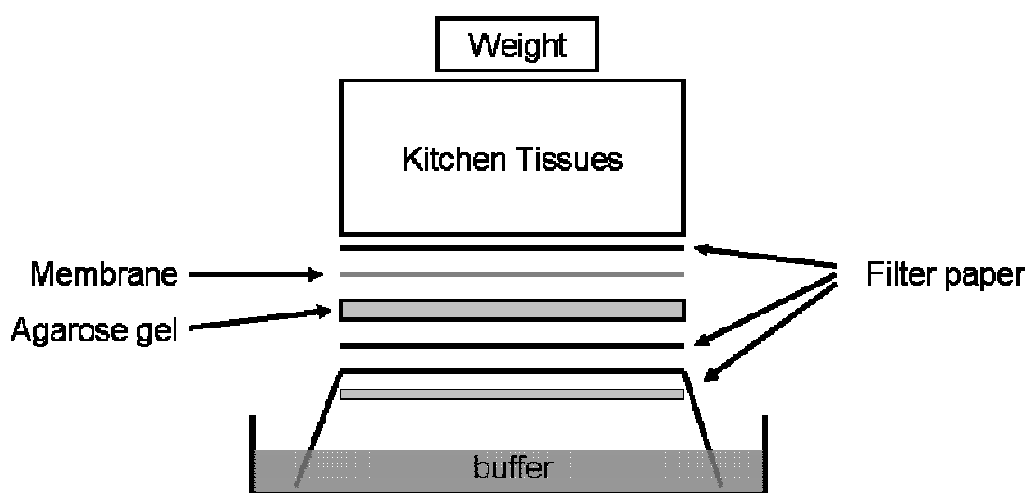

Figure 2.1: Blotting assembly

From the top: 0.5 kg weight, kitchen tissues, filter paper (3 layers), nylon membrane, gel, filter paper (3 layers), bridge-shaped filter paper (1-2 layers), filter paper (3 layers) and blotting buffer (10 x SSC).

2.9.3 Hybridization

The UV crosslinked Southern blot membrane was first pre-wetted in 5 x SSC and then placed in a hybridization bottle (Techne) with 20 ml of pre-hybridization buffer (5 x

SSPE (20xSSPE: 175 g/l NaCl, 27.6 g/l NaH₂PO₄, 9.4 g/l EDTA, pH 7.4), 50% (v/v) deionized formamide, 5 x Denhardt's solution, 10% (w/v) Dextran sulphate Mw 500k, 1% (w/v) SDS and 200 µg/ml ssDNA). The bottle was then incubated in a rolling hybridization oven (Techne) at 42°C for 4 hours. The cDNA probe (20 ng) was labelled with ³²P dCTP by using a Rediprime II DNA Labelling kit (Amersham), following the protocol supplied by the manufacturer. The labelled probe was then purified using a Nick column (G-50, Pharmacia) to remove the unincorporated nucleotides. The purified probe was subsequently denatured for 5 minutes in a 100°C heat block (Techne) and added to the bottle with the membrane and the pre-hybridization solution. The hybridization was carried out overnight at 42°C. The hybridization solution was decanted the next day and the membrane was washed three times with SSPE buffer (Table 2.1).

Table 2.1: Washing the membrane

WASH	SOLUTION	DURATION	TEMPERATURE
First wash	2x SSPE	15 min	25°C
Second wash	2x SSPE and 0.1x SDS	15 min	50-65°C
Third wash	0.2x SSPE and 0.1x SDS	10 min	50-65°C

The duration of the third wash was optimized for each probe due to the differences in length and binding specificity of the probe. Thus the remaining radioactivity of the membrane was continuously monitored during each wash by taking the membrane out of the hybridization bottle, placed in a plastic wrap and scanned using the handheld radioactivity monitor.

After three washes, the membrane was briefly rinsed with 2x SSPE and sealed in a

plastic wrap. The membrane was then placed under an X-ray film (Kodak X-OMAT) in an autoradiography cassette in the dark room under red light. The cassette was wrapped in a dark plastic bag and stored at -70°C for an appropriate length of time. The exposure time can be roughly determined by checking the counts on the membrane using the radioactivity monitor. A membrane with <10 counts requires one week for exposure. Membranes with >20 counts can produce enough signal on the film after 1-2 days.

2.9.4 Development of autoradiography film

The equipment and reagents used for developing films were purchased from Kodak. All procedures were carried out in a darkroom with red light according to the instruction of the manufacturer. The cassette was first warmed to room temperature. The film was immediately placed into a solution with 10% (v/v) developer for about 5 min till the bands were visible, and then rinsed with water in a separated tank with occasional shaking. The fixation was carried out in 5% (v/v) fixer solution; at this point the film was no longer light sensitive. After that the film was rinsed in water and allowed to dry.

2.9.5 Stripping the blot

To reuse the blot, the ^{32}P labeled probes were removed from the membrane by soaking it in boiling 0.1x SSPE solutions for 5 min. The radioactivity of the blot was checked by a handheld monitor. The wash was to be repeated with fresh solution if there was remaining radioactivity. The stripped nylon membrane was rinsed briefly in 5 x SSPE

before sealed in plastic wrap and stored in -20 °C freezer.

2.9.6 Preparation of salmon sperm DNA

100 mg of salmon sperm DNA was added to 10 ml of TE buffer (10 mM Tris-HCl pH 8.0, 0.5 mM EDTA pH 8.0), boiled for 20 min with occasionally shaking/vortex. After the ssDNA was completely dissolved, it was sheared by passing through a 21-gauge needle 12 times using a 25 ml syringe. The solution was then boiled again for 10 minutes. The sheared ssDNA was dispensed to 0.5 ml aliquots in 1.5 ml tubes and stored at -20°C.

2.10 Northern Blot

2.10.1 Electrophoresis of RNA

The following procedures were carried out in the fume hood due to the toxicity of formaldehyde. To prepare the 100 ml formaldehyde northern gel, 90 ml of SDW, 2 ml of sodium phosphate buffer (1 M, pH 6.8) and 1 g of agarose were mixed in a 250 ml flask and melted in a microwave oven. 8 ml of formaldehyde (adjusted to pH 7.0 with NaOH) was added when the gel solution was cooled to 50-60 °C. The gel solution was then poured into the gel caster tray and was left to set in the fume hood for 30 min before use. The volume of the RNA samples was adjusted to 10 µl with SDW and mixed with an equal volume of the sample buffer (50% (v/v) deionized formamide, 16.5% (v/v)

formaldehyde, 40 mM sodium phosphate buffer pH 6.8, 1 mM EDTA pH 8.0 and 10 µg/ml ethidium bromide) in a 1.5 ml tube. The tubes were then incubated in a 65°C heat block for 15 min, snap cooled on ice for 1 min and then briefly centrifuged before adding 1 µl of gel loading dye (Fermentas). Two wells were left empty between the RNA size marker and the first RNA sample. After loading the samples onto the formaldehyde gel, the gel was allowed to run at 80V for 30 min. The gel was then photographed under UV light to compare the amount of the rRNA. The gel was run further until the bromophenol blue dye reached the end of the gel.

2.10.2 Upward capillary blotting

The northern gel was first soaked in 25 mM sodium phosphate buffer (pH 6.8) for 10 min before blotting. The corner of the gel near the loading site was cut to mark the position of the samples. The upward capillary blotting was carried out as that of the Southern blot except that 25 mM sodium phosphate buffer was used as the blotting solution instead of the 10 x SSC (Figure 2.1). After the overnight transfer, the nylon membrane was rinsed in 2 x SSC for 2 min before UV crosslink (Stratalinker 2400, Stratagene). This was followed by baking the membrane in an 80°C oven for 1 hour to evaporate the formaldehyde. The hybridizations, washes and developing procedures were the same as those used in the Southern blot as previously described (Section 2.9).

2.11 Western Blot

2.11.1 SDS-polyacrylamide gel electrophoresis

The western blotting apparatus and consumables are products of Bio-Rad (UK). The SDS-PAGE gel was cast and run in the fume hood due to the toxicity of the acrylamide and β -mecaptoethanol. The SDS-PAGE gel casting apparatus was assembled following the instruction of the manufacturer. The gel mixtures were prepared as described in Table 2.2.

Table 2.2: Recipe for SDS-PAGE gel

Stacking Gel		Resolving Gel	
SDW	3.75 ml	SDW	5.3 ml
50% Gel solution (Bio-Rad)	0.5 ml	50% Gel solution (Bio-rad)	2.0 ml
1M Tris-Cl pH 6.8	0.65 ml	1.5M Tris-Cl pH 8.8	2.5 ml
10% SDS	50 μ l	10% SDS	100 μ l
10% APS	50 μ l	10% APS (fresh)	100 μ l
TEMED	5.0 μ l	TEMED	4.0 μ l

APS: ammonium persulphate, TEMED: tetramethylethylenediamine.

After the resolving gel mixture was loaded into the casting apparatus, SDW (1 ml) was laid on the surface of the gel to produce a smooth finish. The water is then decanted and blotted with filter paper before adding the stacking gel (table 2.2) and the comb. Once the gel was set, the comb was removed and the gel was placed into the vertical electrophoresis tank with 1 x Tris-glycine running buffer (10 x buffer: Tris base 30g/l,

glycine 144g /l and 1% (w/v) SDS). The protein samples were mixed with an equal volume of 2 x sample buffer (125 mM Tris-Cl pH 6.8, 20% (v/v) glycerol, 4% (v/v) SDS, 0.005% (w/v) bromophenol blue and 5% (v/v) β -mecaptoethanol) and denatured at 100oC for 10 min before loading. The SDS-PAGE was run at 100 V for 1 h.

2.11.2 Western blot

The total protein was stained by SimplyBlue Stain (Invitrogen) using the method recommended by the manufacturer. The stained SDS-PAGE gel was to be imaged immediately or dried between two pieces of gel drying film (Promega) for long-term preservation. To transfer the protein to a nitrocellulose membrane, the SDS-PAGE gel was first soaked in the cold transfer buffer (25 mM Tris base, 192 mM glycine and 20% (v/v) methanol, pH 8.3 with HCl) for 5 min. The membrane and 10 pieces of filter paper (Whatman) were cut to the size of the gel and soaked in the transfer buffer prior to use. The paper-membrane-gel-paper sandwich was placed inside the semi-dry transfer machine (Bio-Rad) with the gel side facing the bottom (anode) and the membrane side facing the top (cathode). The transfer was carried out by applying a constant 15 V for 30-45 min. Fresh buffer was poured onto the membrane-gel sandwich when the current began to drop; the excessive buffer was removed with dry tissue.

After the semi-dry electrotransfer, the membrane was rinsed with SDW and placed in a Petri dish with 20 ml blocking buffer (1x TBS with 5% (w/v) nonfat milk powder) with gentle shaking for 1 hour at room temperature. The membrane was transferred to 20 ml

of 1 x TBST (20 mM Tris-Cl pH 7.5, 500 mM NaCl and 0.1% (v/v) Tween-20) and washed for 5 min. The membrane was then incubated with the primary antibody in the dilution buffer (1 x TBST with 1% (w/v) nonfat milk powder) overnight at 4°C on a platform shaker. In the following day, the membrane was washed with 1 x TBST for 5 min and incubated with a secondary AP (alkaline phosphatase) antibody in the dilution buffer for 1-2 h at room temperature. The membrane was then washed three times with 20 ml TBST and once with TBS for 10 min before rinsed with SDW. The membrane was developed in 10 ml of developing solution (SIGMA). The developed membrane was washed with water and dried between two pieces of filter paper.

2.12 Reverse Transcription

The total RNA (10 µg) was mixed with 1 µl of oligodT(25) primer (0.5 µg/µl, MWG) and 1 µl dNTP mix (10 mM each, BioLine) in a 0.5 ml RNase-free tube (eppendorf). RNase-free water was then added to bring the final volume to 23 µl. The tube was incubated at 65 °C for 5 min and this was followed by adding 8 µl 5x RT buffer, 2 µl RNasin (Promega), 4 µl DTT, 1 µl Superscript II (200 U/µl, Invitrogen). The tube was briefly mixed by vortexing and spun down before incubating at 42 °C for 1 h. The reaction was terminated by incubating the tube at 70 °C for 5 min. RNase H (1 µl, Invitrogen) and RNase A (1 µl, Fermentas) were added to the RT reaction mixture to digest the remaining RNA. SDW was then added to bring the final volume to 50 µl and the cDNA was purified using the Wizard DNA clean-up system (Promega) following the protocol supplied by the manufacturer.

After confirming the presence of the transgene by PCR of genomic DNA and Southern blot, a rapid RT-PCR was performed to check whether the transgene mRNA was transcribed. RNA extracted from transgenic plants was reverse transcribed to cDNA by using the BioScript reverse transcriptase (Bioline) with an anchored oligodT primer (5'-cgctacgtaacggcatgacagtgttttttttttttttttttttt-3'). The synthesized cDNA thus carried the anchored tag (indicated by the underline), which served as the reverse primer site for the following PCR step. The reverse primer (5'-cgctacgtaacggcatgacagtg-3') complementary to the anchored tag was then used with a gene specific primer (GSP) to PCR the cDNA. By using this strategy, the PCR will not amplify the genomic DNA contamination present in the cDNA sample, because the genomic DNA does not have the tag sequence. The reverse transcription and PCR procedures were carried out following the protocol supplied by the manufacturer (Bioline).

2.13 Yeast Two-Hybrid Assay

The IntCR clones were obtained from screening a LexA-based tomato fruit cDNA yeast two-hybrid library (Lin *et al.*, 2003). The *Arabidopsis* yeast two-hybrid library is a modified GAL4 system (ProQuest yeast two-hybrid system, Invitrogen) and was kindly provided by Dr. Zoe Willson (Plant Sciences Division, the University of Nottingham).

2.13.1 Transformation of yeast

All following transformation procedures were carried out under sterilized conditions. The solid and liquid cultures of yeast were handled in a sterilized flow hood and all centrifugations were carried out at room temperature. The PEG4000/LiAc solution was prepared in advance and the 10 ml aliquots were kept in the -20°C freezer. The glucose (analytical grade, Fisher) and galactose (BioChemika Ultra, SIGMA) were autoclaved separately in 20% (w/v) water solution before adding to the culture media. The raffinose 20% (w/v) solution was filter sterilized by passing through a 0.45 µm filter unit. The amino acid dropout powder for preparing the SC dropout medium was purchased from BD Clontech and the yeast nitrogen base w/o amino acid was a product of Difco.

The appropriate yeast strain was scraped from a frozen glycerol stock to an YPAD medium (Yeast Extract Peptone Adenine Dextrose, BD Clontech) or a synthetic complete dropout (SC dropout) medium plate and incubated in the inverted position at 30 °C. A single colony (about 2 mm in diameter) was picked from the plate and was used to inoculate 20 ml of the suitable liquid medium in a 100 ml flask. The yeast was grown overnight (about 18 h) at 30 °C in a shaking incubator. The optical density (OD) at 600 nm of the yeast liquid culture was measured in a 1 ml plastic disposable cuvette by the spectrophotometer and the overnight cultured yeast with an OD > 1.5 units was used for the following steps. An appropriate amount of the overnight culture was added to 100 ml of pre-warmed liquid medium in a 250 ml flask to bring the OD to 0.25-0.30. The diluted yeast was grown until the OD doubled to 0.5-0.6 after 3-4 h. The OD of the

yeast culture was measured every 20 min after the initial 2 h to prevent over-growth. The yeast culture was then centrifuged at 1,500 x g for 15 min and washed twice with SDW before suspension in 1 ml LiAc/TE solution (100 mM LiAc, 10 mM Tris-Cl pH 8.0 and 1 mM EDTA). For each transformation, 200 ng of plasmid DNA was mixed with 10 µl of sheared salmon sperm DNA (as prepared in section 2.9.6) in a final volume of no more than 20 µl. The competent yeast cells (100 µl) were added to the DNA mixture and mixed vigorously by vortex. 0.6 ml of the PEG/LiAc solution (40% (w/v) PEG4000 (polyethylene glycol 4000, Sigma), 100 mM LiAc, 10 mM Tris-Cl pH 8.0, 1 mM EDTA, RT) was added to the cells and mixed again by vigorous vortex. The mixture was then incubated in a 30 °C oven for 30 min before adding 70 µl of DMSO (dimethyl sulfoxide, SIGMA). The tube was then mixed by gentle inversions before being heat shocked in a 42 °C water bath for 15 min. The yeast cells were then briefly cooled on ice for 30 sec and pelleted by centrifugation at 2,000 x g for 15 sec. The transformed cells were suspended in 200 µl of SDW and plated onto the appropriate selection medium.

2.13.2 LexA-based yeast two-hybrid assay

The tomato fruit yeast two-hybrid library was built upon the LexA yeast system and all the yeast two-hybrid assays were carried out using the yeast strain EGY48 (*MTA α* , *trp1*, *his3*, *ura3*, *6ops-LEU2*) with DB domain fusion plasmid pEG202 (*HIS3*, *amp^R*), AD domain fusion plasmid pJG4-5 (*TRP1*, *amp^R*) and the reporter plasmid pSH18-34 (*Ura3*, *amp^R*). The plasmid pRFHM1 (*HIS3*, *amp^R*), which expresses LexA-DB fused to the

homeodomain of bicoid, was used as the negative control. The plasmid pSH17-4 (*HIS3*, *amp^R*), which expresses the LexA-DB fused with Gal4-AD was used as the positive control.

For each yeast two hybrid experiment, the competent yeast cells were prepared from yeast EGY48 containing plasmid pSH18-34 grown in SC-U media (6.7 g/l yeast nitrogen base w/o amino acid, 1 g/l minus uracil dropout mixture and 20 g/l glucose, pH to 5.8 with NaOH). The transformed yeast cell containing plasmid pSH18-34, pEG202 and pJG4-5 were plated on SC-UHT medium (SC medium supplemented with 1g/l -Ura -His -Trp dropout mix).

For measuring the *lacZ* reporter activity, the transformed yeast cells were spread on plates with SC-U G/R medium (SC -U medium supplemented with 20 g/l galactose, 10g/l raffinose, 10 mM phosphate buffer pH 7.0 and 80 mg/l X-Gal). The plates were incubated at 30 °C for 2 to 3 days before imaging. The yeast cell expressing proteins with strong interaction was visibly blue in 12 hours (*eg.* the pSH17-4 positive control). The negative control (empty pJG45 and pEG202 plasmids or the pRFHMI) would turn blue after 4 to 5 days due to the basal *LexA* activity. It is thus important to include the negative control in each yeast two-hybrid experiment.

For measuring the *Leu* reporter activity, the transformed yeast cells were suspended in 1 ml of SDW. A series of 1/10 dilution were made covering the 1000 fold concentration

range. The samples (20 µl) from each dilution (1/10, 1/100, 1/1000) was spotted onto plates with SC-UHTL G/R medium (SC medium supplemented with 1g/l –Ura –His –Try –Leu dropout powder, 20 g/l galactose, 10g/l raffinose and pH to 6 with NaOH) and SC-UHTL Glu medium (SC-UHTL with 20 g/l glucose instead of galactose and raffinose). The *Leu* phenotype was scored after 4 to 5 days. The *Leu* positive yeast cell would grow on G/R medium but not the Glu medium.

2.13.3 GAL4-based yeast two-hybrid assay

The GAL4 based yeast two-hybrid library (ProQuest, Invitrogen), which is compatible with the gateway cloning system was kindly provided by Dr. Zoe Wilson. The yeast MaV203 (*MAT α* , *leu2-3*, *trp1*, *his3*, *ade2*, *gal4*, *gal80*, *SPAL10::URA3*, *GAL1::lacZ*, *HIS3UAS GAL1::HIS3@LYS2*, *can1R*, *cyh2R*) was grown in the YPAD medium (10g/l yeast extract, 20 g/l peptone, 100 mg/l adenine sulphate, 20 g/l glucose, pH 6.0 by HCl). The transformed yeast cells were plated on the SC –TL selection medium (6.7 g/l yeast nitrogen base w/o amino acid, 1 g/l –Try –Leu dropout mixture, 20 g/l glucose pH to 5.8 by NaOH).

Filter lift assay was used to analyze the *lacZ* reporter activity. The pre-wetted filter paper (7 cm in diameter) was first placed on top of the solid YPAD medium in the 9 cm Petri dish. The transformed yeast was plated onto the wet filter paper and the Petri dishes were sealed and incubated overnight (20 h) in a 30°C oven in the inverted position. In the following day, the filter paper with yeast cells was peeled and immersed

in liquid nitrogen for 30 sec. The frozen filter was thawed in an empty Petri dish with the yeast side on top. Three pieces of 9 cm filter paper were stacked in the lid of the 9 cm Petri dish; they were saturated with 4 ml of Z buffer (60 mM Na₂HPO₄, 40 mM NaH₂PO₄, 10 mM KCl, 1 mM g/l MgSO₄, 0.5 mg/ml X-Gal, 6 µl/ml β-mercaptoethanol, pH 7.0). The thawed filter paper with the yeast colony side up was then placed on top of the soaked filter paper. The Petri dish was sealed with parafilm and incubated in an inverted position in the 37 °C oven for 24 h. The appearance of blue colour on the filters was observed every 1-2 hours in a 24 hour period, in which the strongest interactions would be visible in the first 2-3 hours. The final result was scored at 24 h and the filter paper was air dried and stored at room temperature.

The *His* reporter assay was carried out by plating the transformed yeast cells in the SC dropout medium with different concentrations of 3-amino-1,2,4-triazole (3AT), which is an inhibitor of the dehydratase encoded by the *HIS* gene. The transformed yeast was picked from the master plate and suspended in 1 ml of SDW. A series dilution of 1:10 was prepared and 10 µl of each dilution was spotted on to the SC -HTL plates (6.7 g/l yeast nitrogen base w/o amino acid, 1 g/l -Try -Leu -His dropout mixture, 20 g/l glucose pH to 5.8 by NaOH) with a 3AT concentration gradient (0 mM, 10 mM, 25 mM, 50 mM and 100 mM). The plates was sealed and incubated at 30 °C for 3 to 4 days.

The yeast activating the *URA* reporter was to be monitored by cell growth on SC plates lacking uracil. In addition, the activated *URA* gene product would convert the

5-fluoroorotic acid (5FOA) to 5-fluorouracil, which is toxic to yeast. Thus the cells containing interacting proteins would grow in uracil minus medium but not on uracil minus medium supplemented with 0.2% (w/v) 5FOA.

2.14 Protein Synthesis and Purification in Yeast

The pESP2 vector, yeast strain (SP-Q01) for expressing GST (glutathione S-transferase) fusion protein and the yeast culture medium were purchased from Stratagene. The GST binding resin was a product of BD Clontech. The primary GST antibody used for western blot detection was obtained from Ambion. The coding sequence of the target gene was first PCR amplified using primers with a 5' *Bam*HI restriction site. The purified PCR product was then digested with *Bam*HI and ligated to the pESP2 vector. The ligation product was transformed to *E. coli* and the plasmid was purified for transforming yeast (SP-Q01) using the PEG/LiAc method (2.13.1).

The transformed yeast cell was used to inoculate a 20 ml yeast extract plus supplements (YES) medium (Stratagene) and cultured overnight at 30 °C. 1 ml of the overnight master culture was added to 100 ml of fresh pre-warmed YES media and grown to mid-log phase (OD₆₀₀ of 0.5-0.8) for 5-7 hours. The yeast cells were then harvested by centrifugation at 1,000 x g for 15 min (RT) and washed twice with SDW before suspension in 200 ml of EMM media (Stratagene). To induce the GST fusion protein production, the yeast in the EMM media was cultured for 24 hours at 30 °C shaking incubator. The yeast cells were then harvested and snap frozen in liquid nitrogen. To

extract the GST-fusion protein, the frozen yeast pellets were grinded for 5 min with alumina powder in a pre-chilled mortar (4 °C). 20 ml of cold 1 x PBS (Sigma) with 2 x proteinase inhibitor (Compleat™, GE) was added to the yeast-alumina mixture and grinded for another 5 min. The alumina and yeast debris were pelleted by centrifugation for 10 min at 12,000 rpm (4 °C) and the supernatant was kept on ice for GST affinity purification.

The GST affinity resin in the column was equilibrated by washing with 5 volumes of cold 1 x PBS three times. The yeast lysate was loaded onto the column and the flow rate was adjusted to 5 ml/min. The column was then washed with 20 volumes of cold PBST (PBS with 1% (v/v) Triton X-100) and eluted with 5 volume of GST elution buffer. The protein concentration of the elution was measured using the Bradford method (Bi-Rad Protein Assay Kit I, Bio-Rad) and visualized by SDS-PAGE and Western Blot.

2.15 Microscopy

2.15.1 Confocal scanning microscopy

The Leica TCS SP2 AOBS confocal scanning microscope was used to image the plant materials expressing fluorescence proteins. The microscope is equipped with the Leica confocal software (LCS), a 100 mW multi-line Argon laser (458 nm, 476 nm, 488 nm, 496 nm and 514 nm) and a 1 mW He-Ne laser (543 nm) as excitation sources. The FP signal was collected by the SP scanner (Table 2.3) and the auto-fluorescence of the

chlorophyll was measured between 630 and 730 nm. The transmitted light image was collected in a separated detector.

Table 2.3: Excitation and emission settings

Fluorescence Protein	Laser	Emission collected
CFP (cyan)	458 nm	465-600 nm; used with YFP: 465-505 nm
GFP (green)	488 nm	500-600 nm
YFP (yellow)	514 nm	525-600 nm; used with mRFP1: 525-560 nm
mRFP1 (red)	543 nm	590-670 nm; used with YFP: 600-725 nm

The plant tissues were mounted on to the glass slide with a drop of 1 x PBS buffer and covered gently with the No. 1.5 cover slip (0.17 mm thick, Scientific Laboratory Supply). The slide was observed under UV light. Once the desired focus and object lens were chosen, the UV shutter was closed the sample was scanned by Leica TCS SP2. The appropriate laser intensity was selected in the Leica Control Software (LCS) accordingly and the live image was acquired instantly through continuous scan mode. The scanner and detector was set to xyz scanning mode, 514x514 image size, 8 bit image and 400 Hz scan rate unless otherwise mentioned. The pinhole was set to AE unit 1 as default. The voltage applied to the photomultiplier tube (PMT, AKA “detector gain value”) was adjusted experimentally to obtain the best signal-to-noise ratio. The z-position and electric-zoom were chosen accordingly and the series z-position scan and image maximal projection was carried out by using LCS. Images were acquired using the 10x/0.4 HC PL APO CS object lens and the 40x/0.7 HCX PL FLUOTAR object lens. The 63x/1.3 HCX PL APO CS and 40x1.25-0.75 HCX PL APO CS object lenses were

used to obtain images where fluorescent proteins were targeted to the endoplasmic reticulum.

2.5.2 Transient expression in onion epidermal cells

The gold powder (sphere 0.8-1.5 μm) was purchased from AlfaAesar and the Particle Delivery System (PDS) He 1000 was a product of Bio-Rad. The gold powder (30 mg) was first washed with 1 ml of ethanol and three times with SDW in a 1.5 ml Low-Bound centrifuge tube (Eppendorf) before suspension in 0.5 ml of SDW. The gold solution was then sonicated for 1 min in a water-bath sonicator (Fisher) and was dispensed to 30 μl aliquots in the Low-Bound centrifuge tubes. The plasmid DNA was coated onto the gold powder by using the CaCl_2 /spermidine method with slight modifications (PDS manual, Bio-Rad).

The gold solution was sonicated for 10 s and vortexed vigorously for 1 min. The plasmid DNA (25 μl) was added to the vortexing gold solution immediately following by addition of 50 μl of 2.5 M CaCl_2 and 20 μl of 0.1 M spermidine (freshly prepared monthly) without delay. The tube was continued to be vortexed for 1 min before settling the gold on ice for 1-3 min. The gold was then pelleted by a 1 sec pulse centrifugation and the supernatant was removed gently without disturbing the gold pellet. Ethanol (150 μl) was gently laid on top of the gold pellet and the tube was again pulse centrifuged for 1 sec. The gold pellet was then washed with 150 μl of ethanol three times without

centrifugation and suspended in 30 μ l of ethanol. The tube was vortexed for 2-3 sec and the gold powder was fully dispersed by pipetting. The gold solution was then loaded to three micro-carriers (Bio-Rad) and dried in a Petri dish with desiccators for about 20 min in a 30°C oven before shooting into the onion epidermal cells.

The inner epidermal cell layer of the onion (locally purchased) was peeled and placed with the inner side down on the Petri dishes with solid MS medium (supplemented with 1% (w/v) sucrose). Water was sprayed onto the Petri dishes to keep the onion peel moisturized. The excessive water on the onion peels was removed by gently blotting with a piece of dry tissue. The gold powders coated with DNA were then bombarded into the onion cell under 26-28 cm Hg vacuum using 1,100 psi rupture disk. The Petri dish was then sealed with parafilm and covered with black cloth. The transformed onion peels were incubated overnight before scoring the transformed cells under the UV lamp.

2.15.3 Forster resonance energy transfer (FRET)

The Fluorescence (Forster) Resonance Energy Transfer (FRET) using CFP and YFP is a technique to measure the distance between two proteins. Typically, protein fused with the CFP was the donor and the YFP fusion protein is the acceptor. The efficiency of FRET can be calculated using the change of the acceptor fluorescence intensity in a living tissue and this method is called sensitized emission FRET (SE-FRET). FRET (A) in a fixed tissue can be measured by the increase of donor fluorescence after photo bleaching the acceptor, thus this technique is named as Acceptor Bleaching FRET. Both

the sensitized emission FRET (FRET-SE) and the acceptor bleaching FRET (FRET-AB) were carried out by using the FRET application wizard in the Leica Control Software (LCS) following the protocol of the manufacturer.

The FRET specimen is generated by co-transforming onion epidermal cells with constructs, in which proteins of interest were fused to CFP or YFP, respectively. The negative control specimen is onion epidermal cells expressing both free CFP and YFP. The positive control specimen is onion epidermal cells expressed a CFP fused to YFP. The two reference specimens are onion epidermal cells expressing either CFP or YFP; they were referred to as CFP reference and YFP reference.

Firstly, the FRET positive control specimen is observed under the UV light and then scanned by the confocal microscope. In the donor channel setting, the acousto-optic tuneable fibre (AOTF) for the 458 nm laser is set to maximum (99.9%) and the photomultiplier tube voltage (PMT) for CFP is adjusted to slightly below detector saturation. Secondly, in the acceptor channel, AOTF for the 514 nm laser and the PMT voltage for YFP fluorescence are also adjusted to just below detector saturation. These donor and acceptor channel settings are saved as default and other specimens are examined under the same conditions. The laser AOTF and detector PMT are then fine-tuned to avoid detector saturation for every sample specimen. Once both the AOTF and PMT settings are optimized for all specimens (FRET, positive control, negative control and two references), FRET images of each sample are then recorded. The donor

only, acceptor only, FRET and background are subsequently chosen in the FRET application wizard and the FRET efficiency was calculated by the application wizard according to Leica's instruction.

CHAPTER 3: RESULTS

3.1 Introduction

3.1.1 Yeast Two-Hybrid System

The protein-protein interaction between the *Arabidopsis* ethylene receptor ETR1 and the downstream MAPKK kinase CTR1 was initially characterized by using the yeast two-hybrid assay (Clark *et al.*, 1998). Yeast two-hybrid is a genetic tool to study protein interactions and to identify novel proteins that can associate with a known protein of interest without the need to know how and where the target protein acts (Bartel and Fields, 1997). The basis of the yeast two-hybrid system relies on the reconstitution of a functional transcription factor which has two separable domains: the DNA binding domain (DB) and the activation domain (AD). There are three types of commercially available yeast two-hybrid systems. The system I is based upon splitting the yeast transcription factor GAL4 into the GAL4-AD and GAL4-DB. Both the system II and III use the *E. coli* LexA as DB and differ in the choice of the activation domain. It is generally considered that the LexA-based systems are more sensitive than the GAL4 system and conversely the GAL4 system is more stringent and produces less false positive results (Criekinge and Beyaert, 1999).

The IntCR (Interacting with CTR2) clones were identified through screening a tomato fruit cDNA library (LexA-based yeast two-hybrid system) using the LeCTR2 N-terminus (aa 192-542) as bait (Lin and Grierson, unpublished data). The tomato fruit

cDNA fragments were inserted into the prey vector pJG4-5, which fused the foreign DNA downstream of the activation domain. The bait cDNA (LeCTR2¹⁹²⁻⁵⁴²) was cloned into the vector pEG202 in frame with the LexA DNA binding domain. The LexA-bait (DB-LeCTR2) fusion protein binds to the LexA operators upstream of the reporter gene. If the bait protein associates with an AD-prey protein, the interaction would activate the two reporter genes and the yeast cells would be able to grow in medium lacking leucine and convert the X-Gal (5-bromo-4-chloro-3-indolyl-beta-D-glacto-pyranoside) substrate to a blue colour product (4-chloro-3-brom-indigo) (Figure 3.1).

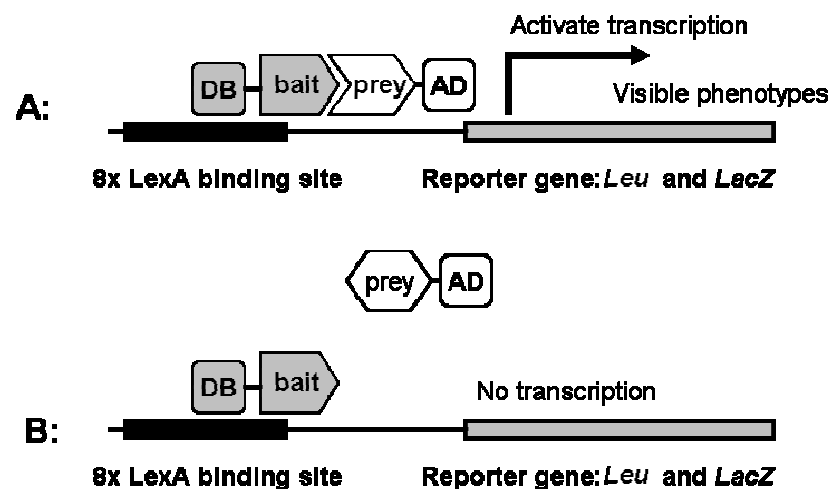

Figure 3.1: The LexA-based yeast two-hybrid system

The bait protein was fused with the DNA binding domain (DB) of LexA, which can bind to the eight LexA binding sites in the reporter plasmid pSH18-34. The prey protein was fused to the activation domain (AD). If the association of the bait and prey occurs, a functional transcription factor is regenerated. This results in the activation of the reporter genes, and produces visible phenotypes. The activation of the *Leu* reporter gene allows the yeast to grow on synthetic dropout media lacking leucine and the gene product of the *LacZ* could change the colour of the yeast colony from white to blue.

3.1.2 Fluorescent Proteins

The green fluorescent protein (GFP) was first discovered in the jellyfish *Aequorea Victoria* as a companion to the bioluminescent protein aequorin (Shimomura *et al.*, 1962). Since then, GFP is widely used in various types of cells as a reporter gene due to its unique *in vivo* fluorescence ability and low toxicity to the host cell (Prasher *et al.*, 1992). The use of GFP in higher plants was not feasible until a cryptic intron inside the coding sequence of the GFP was removed (Haseloff *et al.*, 1997). In addition, extensive mutagenesis screens have been carried out and numerous GFP variants with distinct fluorescence characteristics have been generated (reviewed in Shaner *et al.*, 2005). For instant, the S65T (Serine⁶⁵ changed to Threonine) GFP stabilized the fluorochrome in a permanently ionized form with a single absorbance peak at 489 nm, which became the backbone of the commercially available EGFP (Clontech). The identification of the spectra-shifted GFP variants, such as the blue-shifted cyan fluorescent protein (CFP) and the red-shifted yellow fluorescent protein (YFP) enables multiple proteins to be visualized simultaneously in the same cell (Heim *et al.*, 1994).

Furthermore, it was realized that the Foster resonance energy transfer (FRET) from CFP to YFP could serve as an indicator of the distance between the two fluorescent proteins. FRET is the transfer of the electronic excitation energy between the donor (D) and the acceptor (A). The FRET energy transfer occurs without radiation emission (photons) and is results from the long-range interaction between the D and A dipoles. The efficiency of this process is dependent on the extent of the spectral overlap between the

D emission spectrum and the A absorption spectrum, the quantum yield of A, the respective orientation of the proteins and most importantly, the distance between D and A (reviewed in Periasamy and Day, 2005).

In situations where two proteins are labelled with CFP and YFP, the only variable factor determining the FRET efficiency is the distance between the two fluorescent proteins. Therefore, by measuring the FRET efficiency, the distance of the two target proteins can be determined. However, it is difficult and impractical to obtain the orientation information (orientation factor κ^2) for proteins in a biological system where the protein conformations change rapidly and result in a spread of possible κ^2 . Thus the average value of $\kappa^2 = 2/3$ is generally used for the biological samples.

However, the early FRET measurements were hampered by the poor quantum yield and multiple excitation stages of CFP, plus the pH sensitivity and slow maturation rate of YFP. Therefore, three point mutations (S72A, Y145A and H148D) have been incorporated into CFP in order to stabilize its conformation and resulted in a new CFP variant, called “Cerulean”, which has increased quantum yield, higher excitation coefficient and a single exponential fluorescence life-time (Rizzo *et al.*, 2004). On the other hand, the YFP variant Venus (F46L, F64L, M153T, V163A and S175G) has been generated with better pH sensitivity and folding efficiency when compared to EYFP (Nagai *et al.*, 2002). It should be noted that a new pair of CFP/YFP variants CyPet-YPet had been specifically optimized for FRET experiment (Daugherty *et al.*, 2005). There

has not yet been any published literature on the applications of CyPet-YPet in plant cells and thus a comparison with the Cerulean-Venus pair is not feasible at present.

Quantification of FRET efficiency is generally achieved by measuring the change of the donor or the acceptor fluorescent intensity in acceptor photo-bleaching FRET or sensitized emission FRET. These methods either require complicated algorithms to remove the spectra bleedthrough or cause irreversible photo bleaching and require tissue fixation. The limitations of the intensity-based FRET could be overcome by using the fluorescence lifetime measurement FRET (FLIM-FRET), because the fluorescence lifetime is independent of the fluorophore concentration. However, FLIM-FRET is not widely used because of the requirement for a costly pulse laser source and fast photon-counting detectors.

An alternative technique known as biomolecular fluorescence complementation (BiFC) has been developed (Hu *et al.*, 2002; Hu and Kerppola, 2003). BiFC is based on the ability of two non-fluorescent fragments of a fluorescent protein (e.g. YFP) to re-constitute a functional fluorescent complex. In this approach, neither fragment shows fluorescence by itself, unless the two fragments are brought together by interaction of the two target proteins fused to the fragments. Therefore, BiFC could serve as an indicator of target protein interaction. Because BiFC generates a strong fluorescence signal and direct read-out without the need of employing a complicated algorithm like FRET, it has become widely accepted for measuring *in vivo* protein-protein interaction.

Moreover, multiple protein interactions could be visualized simultaneously within the same cell by using multi-colour BiFC (Hu and Kerppola, 2003; Shyu *et al.*, 2006).

3.2 Sequence Analysis of IntCR

3.2.1 The 5' end sequence of IntCR242 and 266

Plasmids containing the truncated 3' end cDNA fragment of IntCR genes (IntCR242 and 266) and the relevant sequence information were kindly provided by Dr Zhefeng Lin (Plant Sciences Division, University of Nottingham). As the cDNA of the *Arabidopsis* genes (AT1G15730 and FtSH5), which share sequence homology to IntCR242 and IntCR266, are 1.5 kb and 2 kb in length, respectively, it was therefore estimated that about 1 kb of the 5' end cDNA of both the IntCR242 and 266 clones is missing (Figure 3.2).

The rapid amplification of cDNA end (RACE) PCR method was used to obtain the 5' end coding sequence of the IntCR242 and IntCR266 using the RACE primers 5'-atgatcatggccagtatg-3' (IntCR242EXT) and 5'-ggtatcttagcacctaaagcagta-3' (IntCR266EXT) designed according to the manufacturer's protocol (GeneRACE, Invitrogen). The RACE PCR products were gel purified (Figure 3.2) and cloned into vector pGEM-T-Easy (Promega). The DNA sequences were obtained by fluorescence dye terminator sequencing (Appendix A). Based on the 5' end sequence generated from the RACE-PCR, primers were designed to amplify the full-length coding sequence (CDS) of IntCR242 and IntCR266 by RT-PCR. The PCR products were subsequently

cloned into the pENTR SD vector (Invitrogen) and confirmed by sequencing.

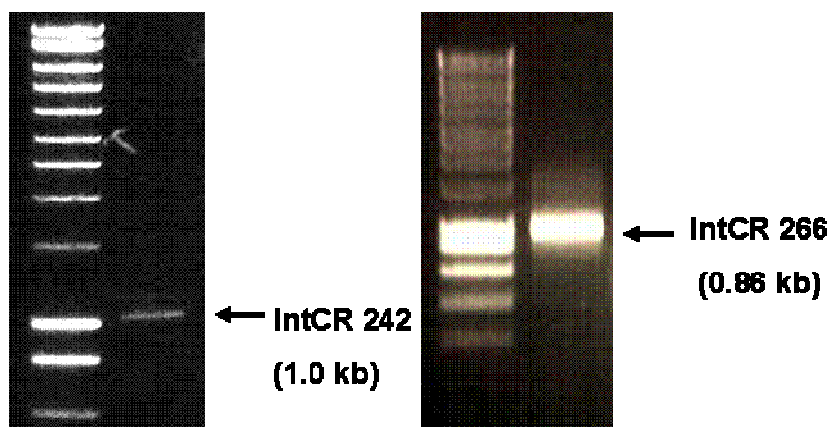

Clones	Length	Estimated full-length cDNA length
IntCR22	710 bp	1.5 k
IntCR242	732 bp	1.5 k
IntCR266	700 bp	2.0 k

IntCR242 forward primer 5' caccatggcttctttgtctatagac 3' (Le242GF)

IntCR242 reverse primer 5' tgtaaacaggctttgaagcc 3' (Le242GR)

IntCR262 forward primer 5' caccatggccaattctgtactctc 3' (Le266GF)

IntCR266 reverse primer 5' agaaatgtatagctcagccttg 3' (Le266GR)

Figure 3.2: RACE-PCR products of IntCR 242 and 266

RACE-PCR was carried out using the total RNA extracted from tomato leaf tissue. The PCR products were separated on a 1% (w/v) agarose gel with the Hyperladder I (BioLine) as molecular weight marker. The lengths of the missing 5' end CDS of the IntCR were estimated by comparing the IntCR sequences with their *Arabidopsis* homologues. The oligos used for RT-PCR are shown above.

3.2.2 Sequence analysis of IntCR242 and IntCR266

The deduced amino acid sequence of the IntCR242 protein showed about 70% identity to both the *Arabidopsis* proteins AT1G15730 and AT1G80480 (Figure 3.3). The N-terminal domain of the IntCR242 protein contains a putative chloroplast transit peptide (cTP) as predicted by the sub-cellular localization prediction programme PSORT (www.psort.org). The putative cTP cleavage site calculated by PSORT is between amino acid residue 73 and 74. Using the IntCR242 protein as entry to search InterPro database (<http://www.ebi.ac.uk/InterProScan>) revealed an ATP/GTP binding site motif A (P-loop) in the amino acid residue 104 to 111 and a vitamin B12 biosynthesis P47K domain in the C-terminus of IntCR242 (Figure 3.3). Interestingly, there is a region (aa 301-421) containing 31 histidine residues in the C-terminus of IntCR242, which is also present in its two *Arabidopsis* homologues AT1G15730 and AT1G80480 (Figure 3.3).

The *IntCR266* gene encodes a protein of 708 amino acids, with a calculated Mw of 75.99 kDa. It has about 80% identity to the *Arabidopsis* FtSH5 and FtSH1 (AT5G42270 and AT1G50250). The amino-terminus of IntCR266 also contains a putative chloroplast transit peptide (cTP) as predicted by PSORT. The IntCR266 protein contains shared features of the chloroplast FtSH ATP-dependent metallo-protease including a cleavable cTP, two transmembrane domains in the N-terminus, two WALKER motifs in the C-terminal half for the Walker-type ATPase/metallo-protease and a zinc binding motif (Figure 3.4).

```

IntCR242      1  -MASHSIDIATTFMGLAKROTPOFYGLRTAVFPTLWKTSKCQRFSLSTSSSSRIS
At1g15730    1  MATLTKLDIATTFIARIVPRANTSIN-----HRAASARIST-----ATVS
At1g80480    1  MATLSTLEIATTFISITAPRSAAFN-----YRFSSAAVSVLSRPRATVS

IntCR242      55  VAINTSSKPNRFS--RGFTVSA▼TSIS-----APQSESDSIIITKIPQDNRI*PAT
At1g15730    41  LRTKSSSFYSALYSDSRRRFHSAVASDSSLAVVDEDEDIFDVASEIILPDNRIPAT
At1g80480    47  VRTTPSFFYSPVW--RRQRFSSVSAS-----ATQIEDSDVITKIPPDNRIPAT

IntCR242     101  IITGFLGSGKTTLLNHILTADHGKRIAVIE NEYGEVDIDGSLVAAKTAGAEIIMM
At1g15730    96  IITGFLGSGKTTLLNHILTGDHGKRIAVIE NEYGEVDIDGSLVAAQTAGAEIIMM
At1g80480    93  IITGFLGSGKTTLLNHILTRDHGKRIAVIE NEYGEVDIDGSLVASKS IGAEDIIMM
          *****

IntCR242     156  LNNGCLCCTVRGDLVRMI*ELVSRKKGKFDHIVIE TTGLANPAPIIQTFY AEDQV
At1g15730    151  LNNGCLCCTVRGDLVRMI*SEMVQTKKGRFDHIVIE TTGLANPAPIIQTFY AEDI
At1g80480    148  LNNGCLCCTVRGDLVRMI*GELVNTKKGKFDHIVIE TTGLANPAPIIQTFY AE*EI

IntCR242     211  FNDVKLDGVVTLVDSKHVGEHLDEIKPKGVVNE AVEQIAYADRI I*VNKTDLVGDS
At1g15730    206  FNDVKLDGVVTLVDAKHARLHLDEVKPEGVVNE AVEQIAYADRI I*VNKTDLVGEP
At1g80480    203  FNDVKLDGVVTLVDAKHARLHLDEVKPEGVVNE AVEQIAYADRI I*VNKTDLVGEA

IntCR242     266  EVSSLIQRIKKNIN*KMAHLKRTQFGKVDLDYVLG IGGFDLIERIES SVGAEG SKEDH
At1g15730    261  ETASVMQRIKTIN*MAHMKRTKYGKVDLDYVLG IGGFDLIERIES SVNEE- EKEDR
At1g80480    258  EIGSVQRIKTIN*MAQMLRTKYGNVDDLDYVLG IGGFDLIERIES SVNEE- DKGDH

IntCR242     321  TGHDDHDDHDDHHH*HD-HDHDHEHEHEHDHKHEHDDHHSHDHTHDP GVS SVS IV
At1g15730    315  EG---HD-DHHHGHDC*HDHHEHEHEHEH-----EHHSHDHTHDP GV*SVS IV
At1g80480    312  HD---HDHDDHH*HN-HDHDH*HHHDGHDH-----HHHSHDHTHDP GVS SVS IV

IntCR242     375  CEGTLDLEKANMWLG*TLLMERSDDIYRMKGLLSVE GMDERFVFQGVHDI*FGSPD
At1g15730    360  CEGDLDLEKANMWLG*TLLYQ*RSEDIYRMKGLLSVQDMDERFVFQGVHDI*FGSPD
At1g80480    356  CEGSLDLEKANMWLG*TLLMERSEDIYRMKGLLSVHTM*ERFVFQGVHDI*FGSPD

IntCR242     430  RPKKSD*ELRTNKIVF IGKNIDAKELEEGFKACTI
At1g15730    415  RLARKDE*TRTNKIVF IGK*NLNREELEMGFRACLI
At1g80480    411  RLKGREE*ERVNKIVF IGK*NLNREELEKGFKACLI

```

Figure 3.3: Amino acid sequence alignment of IntCR242

The sequences alignment of IntCR242 and its *Arabidopsis* homologues At1g15730 and At1g80480 was formatted by T-Coffee and produced by Box-Shade. The black background indicates identity, whereas the grey background represents conservative substitution. The putative cTP cleavage site in the IntCR242 protein is indicated by the black arrow. The ATP/GTP binding site (P-Loop) is indicated by the “*”. The His-rich region is underlined.

```

IntCR266      1  MANSVLSSNFLGSQIFVSPPTPKTSRYFHLHSRRKYIVPCSILSKKSNSDNFKNV
AtFtSH5      1  ---MATSSNPLLLSSNFLGSQIIISAPTPKTTTKSLPFSVISRKRYQISQSEK
      ↓
IntCR266     56  PSKAAIAALLFSSITPQAFALDNTTPAAEPQVIEAEPKPSASNSTPFAQNIIIN
AtFtSH5     52  LMKSLPSQAALAALLFSSSPQALAVNEEVQPPAPTITAEAQSPNISTFGQNVLM

IntCR266    111  APKTQAQPASDIDEGTOWRYSEFLNAVKKGKVERVRFSKDGSILQLTAVDGRRAN
AtFtSH5    107  TAPNPQAQSSDIEDGTOWRYSEFLNAVKKGKVERVKFSKDGSILQLTAVDNRRAT

IntCR266    166  VIVPNDPDLIDILAMNGVDISVSEEGGNGLESVIGNLLFPIIAFAGLEELFRRS
AtFtSH5    162  VIVPNDPDLIDILAMNGVDISVSEEGGNGLEDFIGNLLFPIIAFAGLEYLFRGG

IntCR266    221  OGGPGGPGGLGGPMDFGRSKSKFQEVPETGVTFADVAGADQAKLELQEVDFELKN
AtFtSH5    217  OGGAGGPGGGLGGPMDFGRSKSKFQEVPETGVTFGDVAGADQAKLELQEVDFELKN

IntCR266    276  PDKYTALGAKIPKGCLLVGPPGTGKTLLARAVAGEAGVPPFSCAASEFVELFVGV
AtFtSH5    272  PDKYTALGAKIPKGCLLVGPPGTGKTLLARAVAGEAGVPPFSCAASEFVELFVGV
      Walker A

IntCR266    331  GASRVRDLFEKAKSKAECIVFIDEIDAVGRORGAGLGGGNDEREQTINQLLTEMD
AtFtSH5    327  GASRVRDLFEKAKSKAECIVFIDEIDAVGRORGAGMGGGNDEREQTINQLLTEMD
      Walker B

IntCR266    386  GFSGNSGVIVLAATNRPDVLDSALLRPGRFDROVTVDRPDVAGRVRILQVHSRGK
AtFtSH5    382  GFSGNSGVIVLAATNRPDVLDSALLRPGRFDROVTVDRPDVAGRVQILQVHSRGK

IntCR266    441  ALAKDVDFDKIARRTPGFTGADLQNLMNEAAILAARDLKEISKDEISDALERII
AtFtSH5    437  AIGKDVDFEKVARRTPGFTGADLQNLMNEAAILAARRELKEISKDEISDALERII

IntCR266    496  AGPEKNAVVSDEKKKLVAYHEAGHALVGALMPEYDPVAKISIIPRGOAGGLTFE
AtFtSH5    492  AGPEKNAVVSDEKKRLVAYHEAGHALVGALMPEYDPVAKISIIPRGOAGGLTFE
      Zinc binding motif

IntCR266    551  APSEERLESGLYSRSSYLENQMAVALGGRVAEEVIFGQDNVTTGASNDFMOVSRVA
AtFtSH5    547  APSEERLESGLYSRSSYLENQMAVALGGRVAEEVIFGQDNVTTGASNDFMOVSRVA

IntCR266    606  RMVERFGFSKKIGQVAIGGGGNPFLGQMSSTOKDYSMATADVVDAEVRELVEK
AtFtSH5    602  RMVERFGFSKKIGQVAIGGGAGGNPFLGQMSSSOKDYSMATADVVDAEVRELVEK

IntCR266    661  AVERATQIITTHIDILHKLAQLLIEKETVDGEEFMSLFIDGKAELYIS
AtFtSH5    657  AVVRAKEIITQIDILHKLAQLLIEKETVDGEEFMSLFIDGQAELYVS

```

Figure 3.4: Amino acid sequence alignment of IntCR266

The sequence alignment of the IntCR266 protein and its *Arabidopsis* homologue FtSH5 was formatted by T-Coffee and produced by Box-Shade. The black background indicates identity, whereas the grey background represents conservative substitution. The putative cTP cleavage site in IntCR266 is indicated by the black arrow. The two conserved Walker domains and the zinc binding site are marked by the rectangles.

3.2.3 Sequence analysis of IntCR22

The plasmid containing the full-length cDNA of IntCR22 was purchased from the Institute of Genomic Research (TIGR). The full-length coding sequence (CDS) of IntCR22 was PCR amplified using the forward primer 5'-caccatgggtgttcttactatagagcc-3' and the reverse primer 5'-cataggttttaaattttgcttgc-3'. The purified PCR product was subsequently cloned to pENTR vector (Invitrogen) and sequenced (Appendix A).

The IntCR22 clone encodes a protein of 491 amino acids with a calculated Mw of 56.16 kDa. It has been shown by the BLAST search (<http://www.ncbi.nlm.nih.gov/BLAST/>) that IntCR22 is a member of the UDP-glycosyltransferase (UGT) super-family (Figure 3.5). There are 112 UGTs in *Arabidopsis* and they are classified into 31 sub-families according to the annotation of the Centre of Molecular Plant Physiology (PlaCe, www.p450.kvl.dk/index.shtml). The six *Arabidopsis* UGTs having the highest sequence homology to IntCR22 belong to the UDP-glycosyltransferase 73C sub-family. In addition, all these six UGT73C UGTs are tandem genes at the end of chromosome II ranging from locus 36750 to 36800 in an area about 15 kb in length (Figure 3.5). Only the *in vitro* enzymatic substrates of the UGT73C family member C5 and C6 have been identified so far (see section 1.3.4 for details). Despite the sequence homology and being closely arranged in chromosome II, the 73C5 and 73C6 have different substrate specificities. This suggests that the function of IntCR22 might not be hypothesized solely based on the amino acid sequence.

MIPS	AT2G36780.1		Symbol: None		UDP-glucuronosyl/UDP-glucosyl trans...	559	e-159
MIPS	AT2G36770.1		Symbol: None		UDP-glucuronosyl/UDP-glucosyl trans...	555	e-158
MIPS	AT2G36800.1		Symbol: None		UDP-glucuronosyl/UDP-glucosyl trans...	552	e-157
MIPS	AT2G36750.1		Symbol: UGT72C1		UDP-glucuronosyl/UDP-glucosyl tr...	543	e-155
MIPS	AT2G36760.1		Symbol: None		UDP-glucuronosyl/UDP-glucosyl trans...	538	e-153
MIPS	AT2G36790.1		Symbol: None		UDP-glucuronosyl/UDP-glucosyl trans...	535	e-152
MIPS	AT3G53160.1		Symbol: None		UDP-glucuronosyl/UDP-glucosyl trans...	481	e-136
MIPS	AT3G53150.1		Symbol: None		UDP-glucuronosyl/UDP-glucosyl trans...	461	e-130
MIPS	AT4G34138.1		Symbol: None		UDP-glucuronosyl/UDP-glucosyl trans...	374	e-104
MIPS	AT4G34135.1		Symbol: None		UDP-glucuronosyl/UDP-glucosyl trans...	373	e-103
MIPS	AT2G15490.1		Symbol: None		UDP-glucuronosyl/UDP-glucosyl trans...	372	e-103
MIPS	AT2G15480.1		Symbol: None		similar to UDP-glucuronosyl/UDP-glu...	368	e-102

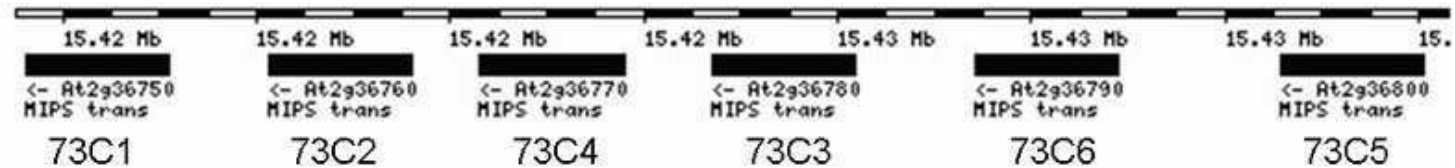

Figure 3.5: *Arabidopsis* homologues of IntCR22

The amino acid sequence of IntCR22 was used as entry for BLAST (NCBI) search of the *Arabidopsis* protein database. The first six proteins (black rectangle) with the highest homology to IntCR22 comprise the *Arabidopsis* UDP-glycosyltransferase (UGT) sub-family 73C and cluster in chromosome II from 15417 kb to 15432 kb. All the 73C UGT members lack introns in their genomic DNA sequence. The schematic diagram representing the genomic DNA region containing the six 73C UGTs was obtained from the AtEnsemble Genome Browser.

3.3 Expression of IntCR Genes

It should be noted that the general expression patterns of IntCR (Interacting with CTR2) genes in tomato tissues of different developmental stages and in response to several phytohormones have already been reported (Lin *et al.*, 2003). The authors showed that the LeCTR2 and IntCR genes are highly expressed in ripening fruit by using northern blot assays. In addition, it has also been shown that the mRNA levels of LeCTR2 and IntCR were affected by mechanical wounding, pathogen attack and JA treatments (Lin and Grierson, unpublished data).

3.3.1 IntCR242 is not alone

The sequence analysis revealed that *IntCR22* and *IntCR266* could belong to large gene families as indicated by the *Arabidopsis* genomic information (Section 3.2.2 and 3.2.3). However, there are only two *Arabidopsis* genes having sequence homology to the tomato *IntCR242*. In order to obtain information about the size of the tomato *IntCR242* gene family, the tomato genomic DNA was subjected to Southern blot analysis.

PCR was carried out with primers 5'-cctggtgttcttctgtcag-3' (forward) and 5'-tgtaaacaggcttgaagcc-3' (reverse) using tomato genomic DNA as template. The 0.4 kb PCR product was purified and used for generating the cDNA probe as previously described (Section 2.9.2). The tomato genomic DNA was digested with *Xho*I, *Hind*III and *Eco*RI, respectively. The digested genomic DNA fragments were separated by

electrophoresis and analyzed by Southern blot assay. Because the probe lacks the restriction sites of the aforementioned enzymes, the endogenous *IntCR242* gene could only produce one band in the Southern autoradiography film. The probe hybridized to two bands in the *Xho*I digested genomic DNA and three bands in the *Eco*RI digested genomic DNA. This multiple bands hybridization pattern indicates that there is either more than one copy of *IntCR242* in the tomato genome or the presence of two or more *IntCR242*-like genes (Figure 3.6). However, a single 8 kb band was found in the *Hind*III digested genomic DNA (Figure 3.6 lane 3). It is possible that *Hind*III digestion has generated multiple DNA fragments of the same length that could not be separated by electrophoresis. Alternatively, the missing DNA fragments could be too large to be efficiently transferred to the membrane.

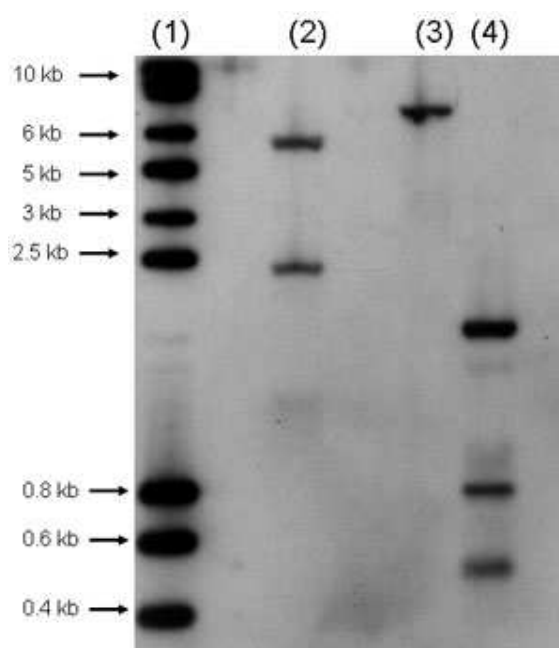

Figure 3.6: Southern blot of *IntCR242*

The tomato genomic DNA was digested with appropriate restriction enzyme and the Southern blot assay was carried out as described in section 2.9. From left to right: 1) Molecular weight marker Hyperladder I; 2) Genomic DNA digested with *Xho*I; 3) Genomic DNA digested with *Hind*III; 4) Genomic DNA digested with *Eco*RI.

3.3.2 Expression patterns of IntCR

Before analyzing the expression patterns of the IntCR genes, possible circadian rhythm of target gene expression was investigated by northern blot assay. RNA was extracted at different time points over a 24 h period from the leaf tissues of the 1 month-old tomato plants maintained in the growth room (18 h photoperiod). Northern blot assay was carried out to detect the IntCR transcripts in these RNA samples. It showed that IntCR299, IntCR266 and *LeApL3* are constitutively expressed, while the expression of IntCR242 and *E4* varies at different time points. IntCR22, however, showed reduced expression from 9:00 to 18:00, which corresponds to the light period (Figure 3.7). Thus, it was hypothesized that light might down-regulate the IntCR22 expression and further northern blot assay was then carried out to compare the RNA extracted from the light- and dark-grown seedlings. It showed that the IntCR22 RNA level is indeed higher in the dark-grown seedlings, whereas the transcripts of IntCR242 and IntCR266 decreased in the light-grown seedlings (Figure 3.8).

IntCR299 is a constitutively expressed DNAJ chaperone gene and was used as a control for equal loading in the northern blot assay. The cDNA probe for the ethylene regulated methionine sulphoxide reductase gene *E4*, was kindly provided by Dr Zhefeng Lin. The tomato *ADP-GLUCOSE PYROHOSPHORYLASE LARGE SUBUNIT3 (LeApL3)*, which is a sugar regulated gene, was used as the endogenous sugar content marker. The 3' end fragment of IntCR in plasmid pJG4-5 was released by *EcoRI* and *XhoI* digestion and purified for generating a cDNA probe for the detection of the IntCR genes.

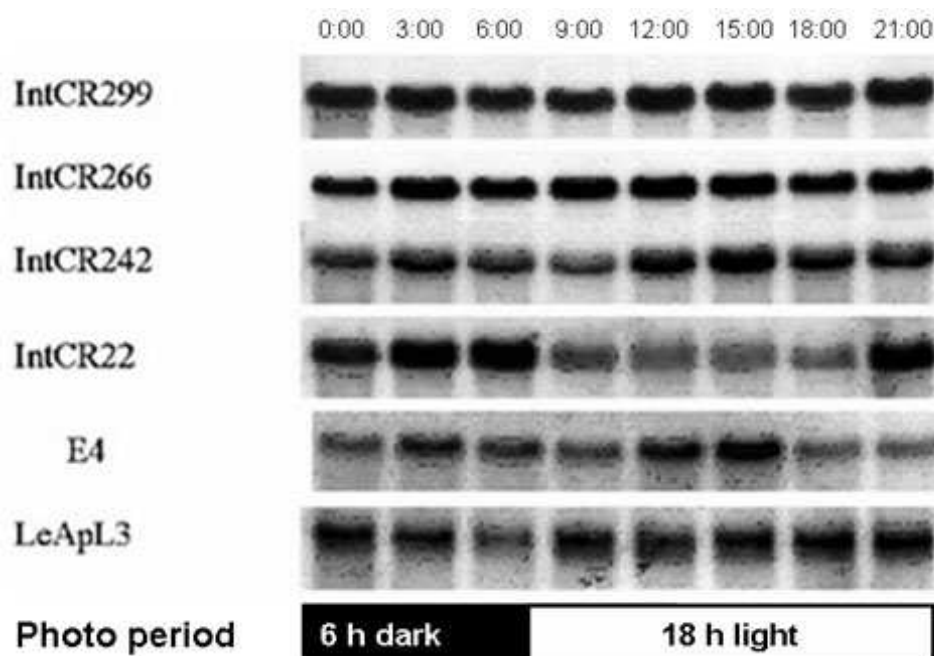

Figure 3.7: Northern analysis of IntCR over a 24 h period

Northern analysis was performed using 10 μ g of total RNA extracted from tomato leaf tissue collected at different time points (indicated by the time above). The northern blot membranes were hybridized to cDNA probes generated from the IntCR, *E4* and *LeApL3* genes. The ethylene regulated *E4* and the sugar regulated *LeApL3* were used as controls. IntCR299, a constitutively expressed DNAJ chaperon gene was also probed to confirm the equal loading of RNA.

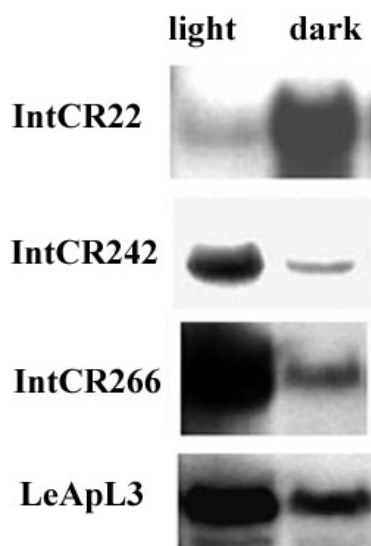

Figure 3.8: Expression of IntCR in the dark/light grown seedlings

RNA was extracted from 2 week-old tomato seedlings grown in the presence or absence of light. Northern blot analysis was carried out using 10 μ g of total RNA and hybridized to 32 P labelled cDNA probes targeting the IntCR genes. The LeApL3, which is positively regulated by the sugar level, was probed as control.

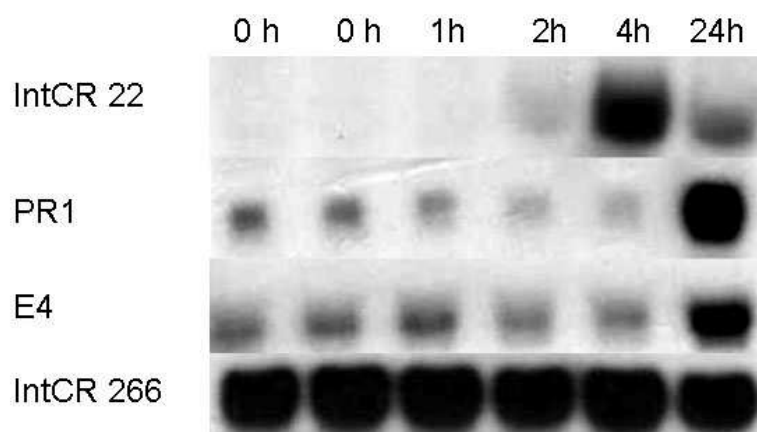

Figure 3.9: SA induced expression of IntCR22

One month-old tomato plants grown in the glasshouse were sprayed with 0.5 mM salicylic acid (dissolved in water with 0.005% (v/v) silvet-77) and RNA was extracted from leaf tissue for northern blot analysis. The duration of the SA treatment is indicated above. The first two columns are zero hour negative control. The SA regulated *LePR1b* gene (positive control) increased a day after the SA treatment. The constitutively expressed IntCR266 were used as the control of the equal loading and *E4* was used as a control for the ethylene response.

3.3.3 The *IntCR22* is up-regulated by SA

The previous northern blot experiments (Figure 3.6 to 3.8) showed that the expression of *IntCR22* could be controlled by environmental factors such as light and timing. In addition, it has been reported that *IntCR22* is related to defence response and its expression is regulated by plant growth regulators like ABA and JA (Lin *et al.*, 2003). Salicylic acid (SA) is a phytohormone involved in stress responses, defence responses and programme cell death. Thus, the expression level of *IntCR22* was monitored in the SA sprayed plants by northern blot assay (Figure 3.9). It was shown that the mRNA accumulation of *IntCR22* was induced 2 h after the SA treatment. The positive control for SA treatment is *LePR1b* (kindly provided by Dr. Zhefeng Lin), which is up-regulated by SA (24 h after the SA treatment). The ethylene regulated gene *E4* was also probed and showed an induction pattern similar to that of the *LePR1b* gene.

3.4 Analysis of Yeast Two-Hybrid Interactions

3.4.1 The His-rich domain is responsible for the interaction of *IntCR242*

The sequence analysis revealed that there is a putative chloroplast transit peptide (cTP) in the N-terminus of *IntCR242*, followed by an ATP binding site (P-loop) and a histidine-rich region (see section 3.2.2 for details). It has also been shown that *IntCR242* has the strongest interaction with the tomato ethylene receptor ETR1 and the putative CTR1-like protein kinase CTR2 in the yeast two-hybrid assay (Lin and

Grierson, unpublished data). In order to identify the domain in IntCR242 responsible for its interaction with the ethylene receptor and the putative downstream kinase, five constructs containing truncated IntCR242 fragments of different length were tested for interaction with the LeETR1 and LeCTR2 in the yeast two-hybrid assay (Figure 3.10). The aforementioned fragments were generated by PCR amplification of a full-length IntCR242 cDNA clone (Table 3.1) and the PCR products were cloned into the yeast two-hybrid prey vector pJG4-5. The subsequent yeast two-hybrid experiment was carried out as previously described (Section 2.13).

The yeast two-hybrid assay showed that only the C-terminal domain of IntCR242 (construct No. 4) containing the His-rich region is capable of associating with the ethylene receptor LeETR1 and the putative downstream kinase LeCTR2 (Figure 3.11). The construct No. 5, in which the His-rich region is deleted, could not interact with LeETR1 and LeCTR2. This showed that the His-rich domain in IntCR242 is essential for its *in vitro* protein-protein interaction. Interestingly, no interaction was observed in the yeast two-hybrid assay using the construct 1, 2 and 3. This suggested that the inclusion of any N-terminal sequence of IntCR242 before the His-rich region might mask its ability to associate with LeETR1 and LeCTR2. The His-rich region in the IntCR242 protein is 42 amino acid residues in length, containing 11 His-Asp (H-D) repeats and 4 His-Glu (H-E) repeats (Figure 3.12). Both aspartic acid and the glutamic acid are negatively charged amino acid residues and this region is likely to associate with positively charged proteins through ionic interactions.



Figure 3.10: Schematic diagram of IntCR242 constructs

Five IntCR242 deletion constructs were generated for the analysis of their interactions in the yeast two-hybrid assay to map the region responsible for the interaction of IntCR242.

- 1: The full-length IntCR242 protein (aa 1 to 463).
- 2: The construct without the chloroplast transit peptide (cTP, aa 93 to 463).
- 3: The fragment minus ATP binding site (aa 112 to 463).
- 4: The His-rich domain (aa 249 to 463).
- 5: The C-terminal fragment minus the His-rich domain (aa 369-463).

Table 3.1: Primers for PCR amplification of the IntCR242 constructs

Construct	Forward primer	Reverse primer
1: full-length	cacatggcttctttgtctataga	cataggtttaaaatTTTTgcttgc
2: w/o cTP	aactcgaggataatcgaattccagctacc	aactcgagcataggtttaaaatTTTTgcttgc
3: w/o P-loop	tgaattcaccttattaaatcacatattgact	aactcgagcataggtttaaaatTTTTgcttgc
4: His-rich	agaattcgatcttgttggtgattct	aactcgagcataggtttaaaatTTTTgcttgc
5: w/o His-rich	aagaattccctggtgtttcttctgtcag	aactcgagcataggtttaaaatTTTTgcttgc

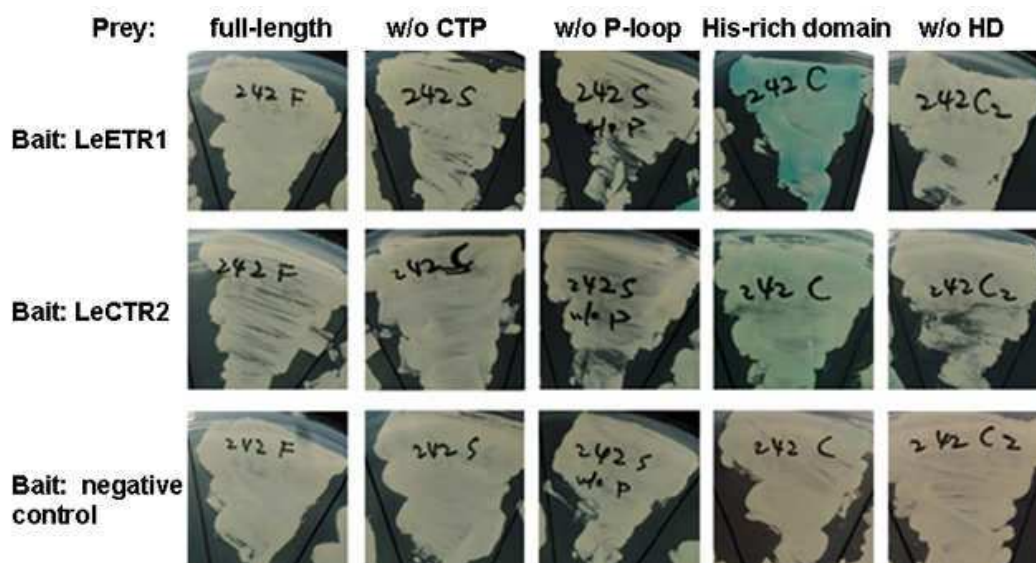

Figure 3.11: Yeast two-hybrid assay of IntCR242

Yeast was transformed with the bait and prey plasmids and grown on synthetic dropout medium (2% galactose, 1% raffinose and 20 mg/l X-Gal). The *LacZ* reporter was only activated (blue coloured colony) in yeasts expressing the His-rich domain of IntCR242 (aa 249-463) with either LeCTR2 or LeETR1. This suggested that the His-rich region of IntCR242 is responsible for the association with LeCTR2 and LeETR1. The His-rich domain expressed with the negative control protein did not activate the *LacZ* reporter, which showed that the IntCR242 protein-protein interaction is not due to self-activation of the reporter gene. The original images of the yeast were taken by Mrs Laura Allard (photographic unit, Sutton Bonington Campus, the University of Nottingham) (yeast two-hybrid\Oct 2004 IntCR242 deletion Y2H). The bait LeETR1 (aa 126-754), LeCTR2 (aa 195-537) and the negative control plasmid (pRFHM1, the homeodomain of bicoid) were all kindly provided by Dr Zhefeng Lin. It should be noted that the yeast two-hybrid interactions between IntCR and ETR/CTR have been reported in a separated experiment (Lin *et al.* 2003).

```

301 GFDLERIESS VGAEGSKEDH TGHDHDDHDDH HHHHHDHDH HEHEHEHDHK HEHHDHHHS
361 DHTHDPGVSS VSIVCEGTLD LEKANMWLGT LLMERSDDIY RMKGLLSVEG MDERFVFQGV

```

Figure 3.12: The His-rich region in IntCR242

The amino acid residues 301 to 421 of IntCR242 were shown. The histidine (H) residues are presented in red. The aspartic acid (D) residues are indicated by the blue colour.

3.4.2 IntCR242 associates with other IntCR proteins

The *Arabidopsis* ethylene receptor ETR1 is known to be able to form a protein complex with CTR1 in the ER membrane (Gao *et al.*, 2003). It has also been shown that the IntCR proteins can associate with the tomato ethylene receptor LeETR1 and the putative CTR1-like MAPKKK LeCTR2 in the yeast two-hybrid assay (Lin *et al.*, 2003). Thus, it has been hypothesized that the IntCR proteins are part of the ethylene receptor LeETR1-LeCTR2 complex in tomato (Dr. Zhefeng Lin, personal communication). To test this hypothesis, the interaction among the IntCR proteins was examined by the yeast two-hybrid assay. The DNA fragment encoding the His-rich region of IntCR242 (construct 4 in Figure 3.11), which has been shown to be important for its interaction with the ethylene receptor LeETR1 and the putative downstream kinase LeCTR2, was released from the pJG4-5 plasmid by *EcoRI* and *XhoI* digestion. It was then cloned into the *EcoRI* and *XhoI* linearized yeast two-hybrid bait vector pEG202. The N-terminus of IntCR242 (minus the His-rich region) was also cloned into the pEG202 (bait) plasmid and used in the yeast two-hybrid assay as a negative control.

The yeast two-hybrid assay results indicated that the C-terminal domain of IntCR242 was indeed capable of associating with all the IntCR proteins (IntCR22, IntCR242, IntCR266 and IntCR299), whereas the N-terminus of IntCR242 as a negative control showed no interaction with any proteins (Figure 3.13).

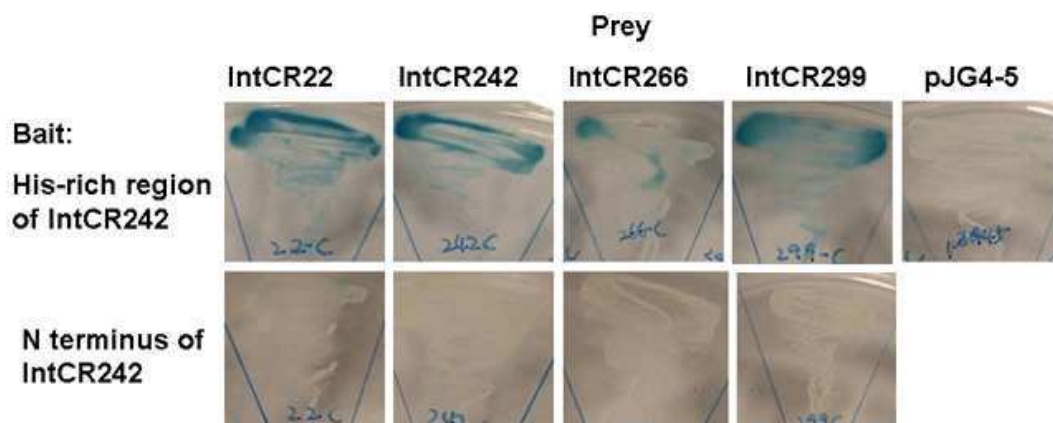

Figure 3.13: Interaction between IntCR proteins

The *LacZ* reporter gene was activated when the His-rich domain of IntCR242 (bait) was expressed with the IntCR proteins (prey) but not the negative control (pJG4-5 alone). The N-terminus of IntCR242 (without the His-rich region) did not interact with any IntCR protein. The results indicate that IntCR242 can associate with the IntCR proteins (including IntCR242 itself) in the yeast two-hybrid assay, and the His-rich domain is likely to be responsible for the interaction.

The IntCR clone 299 was another IntCR clone, which has specific interaction with LeCTR2 but showed no interaction with LeETR1 (Lin and Grierson, unpublished data). The empty prey plasmid pJG4-5 was used as the negative control. The yeasts were transformed with the bait (the His-rich region of IntCR242, aa 264-463) and the prey plasmids and grown on synthetic dropout medium supplemented with 2% (w/v) galactose and 1% (w/v) raffinose. The prey plasmids (IntCR22³³³⁻⁴⁹¹, IntCR266²⁶⁷⁻⁷⁰⁸ and IntCR299³¹⁸⁻⁴³⁰) were kindly provided by Dr Zhefeng Lin.

The original images of the yeast taken by a hand-held digital camera are shown in saved in the accompanied CD (\yeast two-hybrid\Apr 2004 Interaction between IntCR).

3.5 IntCR266 Complements the *Arabidopsis* Mutant *var1-1*

As previously mentioned, IntCR266 shares sequence homology to members of the *Arabidopsis* FtSH metallo-proteinase family (see section 3.2.2 for details). The FtSH proteins are generally involved in degrading the photo-damaged photo-system II and the *Arabidopsis* FtSH5 loss-of-function mutant (*var1-1*) is hypersensitive to strong light and forms white/yellow patches on leaves.

In order to determine the biological function of IntCR266, a mutant complementation experiment was carried out. The full-length CDS (coding sequence) of IntCR266 was cloned into pENTR vector and recombined to the binary plasmid pGWB8 as previously described (Section 2.8.2). The T-DNA region in the binary plasmid pGWB8-IntCR266 contains the CDS of IntCR266 inserted between a CaMV 35S promoter and a terminator (Figure 3.14). *Agrobacterium* (C58) harbouring this construct (pGWB8-IntCR266) was then used to transform the *Arabidopsis* mutant *var1-1* by using the floral dip method (Section 2.3.3). Three independent transgenic lines were obtained and named as *var1-1*::pGWB8-IntCR266.

The transgenic *var1-1* lines showed phenotypes similar to the wild-type *Arabidopsis* (Figure 3.15). The leaf variegation phenotype of the *var1-1* was not observed in the transgenic lines. The rosette size of the transgenic plants is larger when compared to the *var1-1* mutant plants. These observations suggested that the expression of IntCR266 in the AtFtSH5 LOF mutant *var1-1* could complement its leaf variegation phenotype and

the tomato IntCR266 is a functional metallo-proteinase homologous to the AtFtSH5 (VAR1). However, some yellow sectors were occasionally observed on the leaves of the second generation plants, which is similar to the variegation in leaves of the *var1-1* mutant (data not shown). This might result in the local silencing of the IntCR266 transgene or a partial complementation.

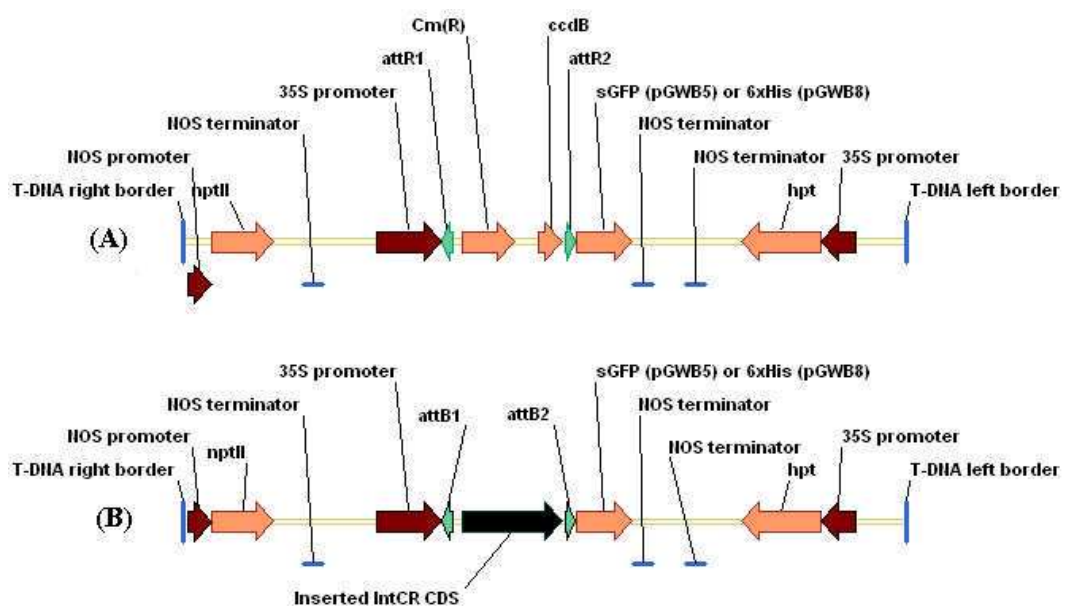

Figure 3.14: T-DNA region of the pGWB plasmids

The schematic diagram of the T-DNA region of plasmid pGWB5 and pGWB8 was generated by Vector NTI (Invitrogen). After cloning the IntCR into the plasmid through LR recombination, the two *attR* sites in the pGWB plasmids (A) were changed to *attB* sites with the CDS of IntCR inserted between the two *attB* sites (B). The CaMV 35S promoter is used to drive the transgene expression in plant and the CDS of IntCR was fused in frame with either the downstream sGFP (pGWB5) or 6xHis tag (pGWB8). The kanamycin resistance gene (*nptII*) and hygromycin resistance gene (*hpt*) are placed near the T-DNA border to provide two antibiotic selections in plants.

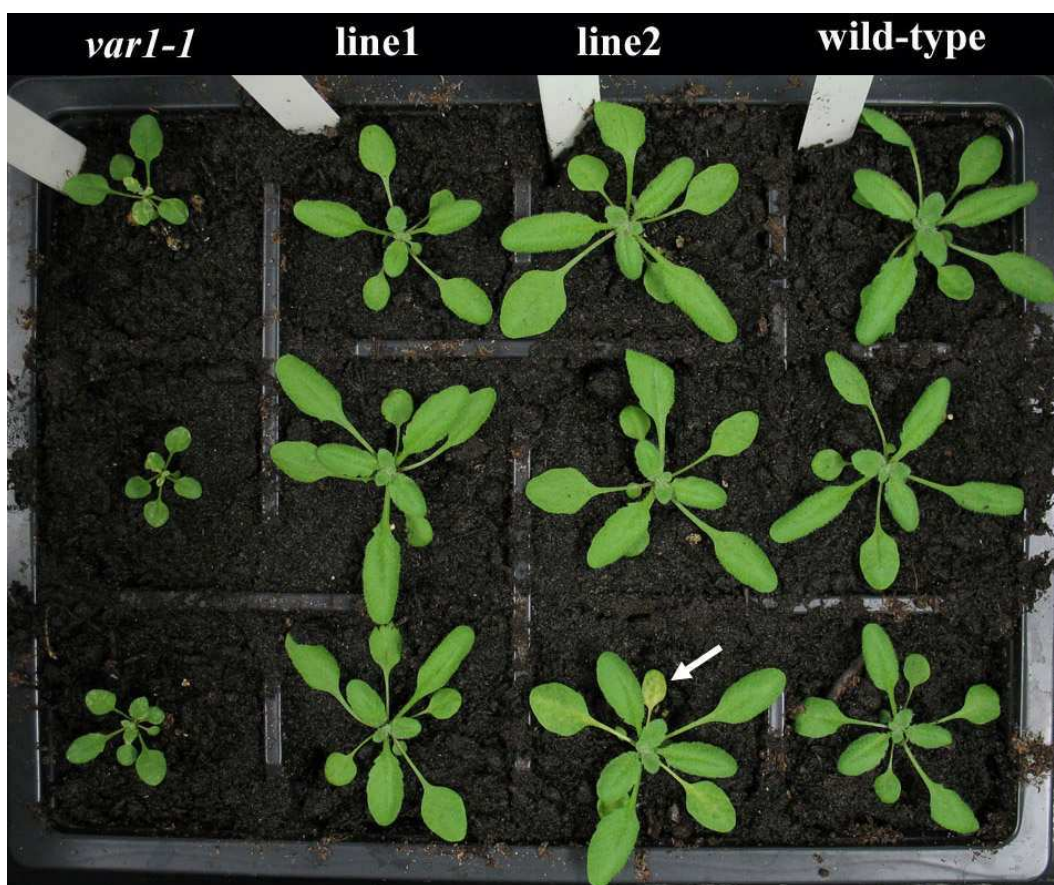

Figure 3.15: IntCR266 transgene rescued the *var1-1* mutant phenotype

Image of the one month old *Arabidopsis* plants grown in the 18 h photoperiod growth room was captured using a hand-held digital camera. The line 1 and 2 are *var1-1* mutant transformed with the construct expressing the cDNA of IntCR266. The leaf variegation phenotype of *var1-1* is restored to wild-type in these transgenic lines. The rosette size of the transgenic lines is also bigger than that of the *var1-1* mutant. One leaf (indicated by the arrow) of the line 2 plant developed yellow sectors similar to those of the *var1-1* mutant.

3.6 Sub-cellular Localization of IntCR

3.6.1 Constructs

Both IntCR242 and IntCR266 have putative chloroplast transit peptide (cTP) in the N-terminal domain and are predicted to be chloroplast proteins by the sub-cellular localization analysis software PSORT (see section 3.2.2 for details). It has been shown that the IntCR proteins can associate with both ethylene receptor LeETR1 and a putative downstream Raf-like kinase LeCTR2 in yeast (Lin *et al.*, 2003). Although the localizations of the tomato ethylene receptors and the putative kinase LeCTR2 have not yet been identified, their homologues in *Arabidopsis* had been located to the ER membrane (Chen *et al.*, 2002; Gao *et al.*, 2003). Thus, the key question is how the chloroplast-located IntCR242 and IntCR266 interact with the ethylene signalling components if they have different sub-cellular localizations.

In order to identify the localization of the IntCR proteins, the recombinant IntCR proteins were expressed in transgenic tobacco plants with the green fluorescence protein (GFP) fused to the C-terminal domain of IntCR. The initial efforts to visualize the IntCR-GFP proteins in plants were unsuccessful (data not shown). Thus, the GFP variant EGFP (enhanced GFP, BD Clontech) was used as the fusion tag of the IntCR proteins in the following studies. The codon of the enhanced GFP has been optimized for expression in mammalian cells and has been suggested to have better intrinsic brightness than the original GFP (GFP manual, BD Clontech). The binary plasmid

pK7FWG2 (Karimi *et al.*, 2002) used for generating the EGFP hybrid protein was purchased from the Functional Genomics Division of the Department of Plant Systems Biology, University of VIB-Ghent. The IntCR cDNA was cloned into the pK7FWG2 through LRTM recombination (Invitrogen) as described previously in section 2.8.2. The T-DNA regions of PK7FWG2 before and after cloning are shown in Figure 3.16.

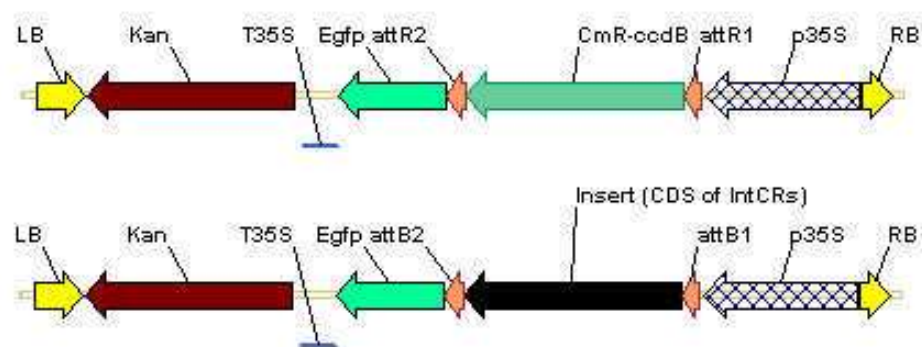

Figure 3.16: T-DNA region of binary vector pK7FWG2

The schematic diagram of the T-DNA region of PK7FWG2 before and after inserting the IntCR cDNA is shown in the picture generated by Vector NTI (Invitrogen). After the recombination, the CDS of IntCR replaces the Gateway cassette in between the two *attR* sites. From left to right: left border (LB); kanamycin resistance gene (Kan); CaMV 35S terminator (T35S); recombination sites (*attB* or *attR*); enhanced green fluorescent protein (EGFP); the CDS of IntCR; CaMV 35S promoter (p35S); right border (RB).

3.6.2 IntCR242 and IntCR266 are targeted to chloroplast

To study the sub-cellular localization of the IntCR242 and IntCR266 protein, wild-type tobacco plants were transformed with the IntCR-EGFP constructs using *Agrobacterium* as previously described (Section 2.3.2). Three IntCR242-EGFP lines and two IntCR266-EGFP lines have been generated.

The GFP fluorescence (green) and the chlorophyll auto-fluorescent (red) in the transgenic tobacco leaf epidermal cells were imaged simultaneously by using the confocal scanning microscope as previously mentioned (Section 2.15.1). The IntCR242-EGFP protein was found predominantly in the chloroplasts of the tobacco epidermal cells (Figure 3.17). The GFP fluorescence was also present in a punctated structure scattered in the cytoplasm. These structures lack the red chlorophyll auto-fluorescence as might possibly be mitochondria. The stromule, which is the tubular extension of the plastid normally found in cells containing non-green plastids, was also highlighted by the IntCR242-EGFP (Figure 3.18). The *Arabidopsis* homologue (AT1G15730) of IntCR242 was also expressed in tobacco with EGFP tag and the localization of the fusion protein was identical to IntCR242 (Figure 3.19 A and B). The IntCR266 protein also contains a putative cTP as predicted by PSORT (see section 3.2.2 for details). The fluorescence images suggested that the IntCR266-EGFP was indeed targeted to the chloroplasts of the transgenic tobacco leaf epidermal cells (Figure 3.19 C and D).

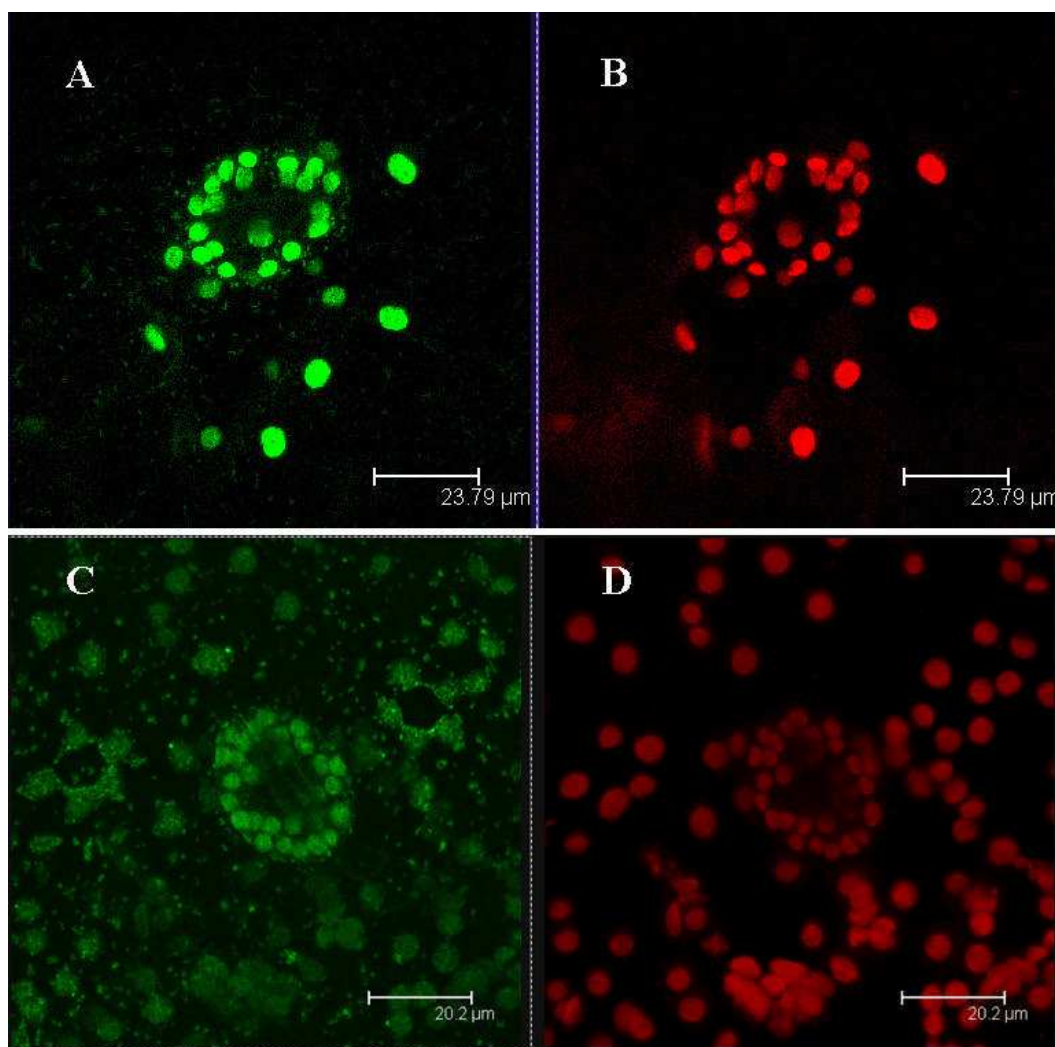

Figure 3.17: IntCR242-GFP in transgenic tobacco leaf epidermal cells

The green fluorescence of IntCR242-EGFP was found in the chloroplast of the guard cell and the epidermal cells. The green dots scattering in the cell represented the IntCR242-EGFP in an unknown punctated structure, which might be mitochondria. Left: GFP image; right: the red chlorophyll auto-fluorescence. The scale bars are shown in the bottom right.

A and B: Lower epidermal cell peel of the transgenic tobacco leaf expressing the IntCR242-GFP construct.

C and D: A leaf disk mounted directly on a glass slide.

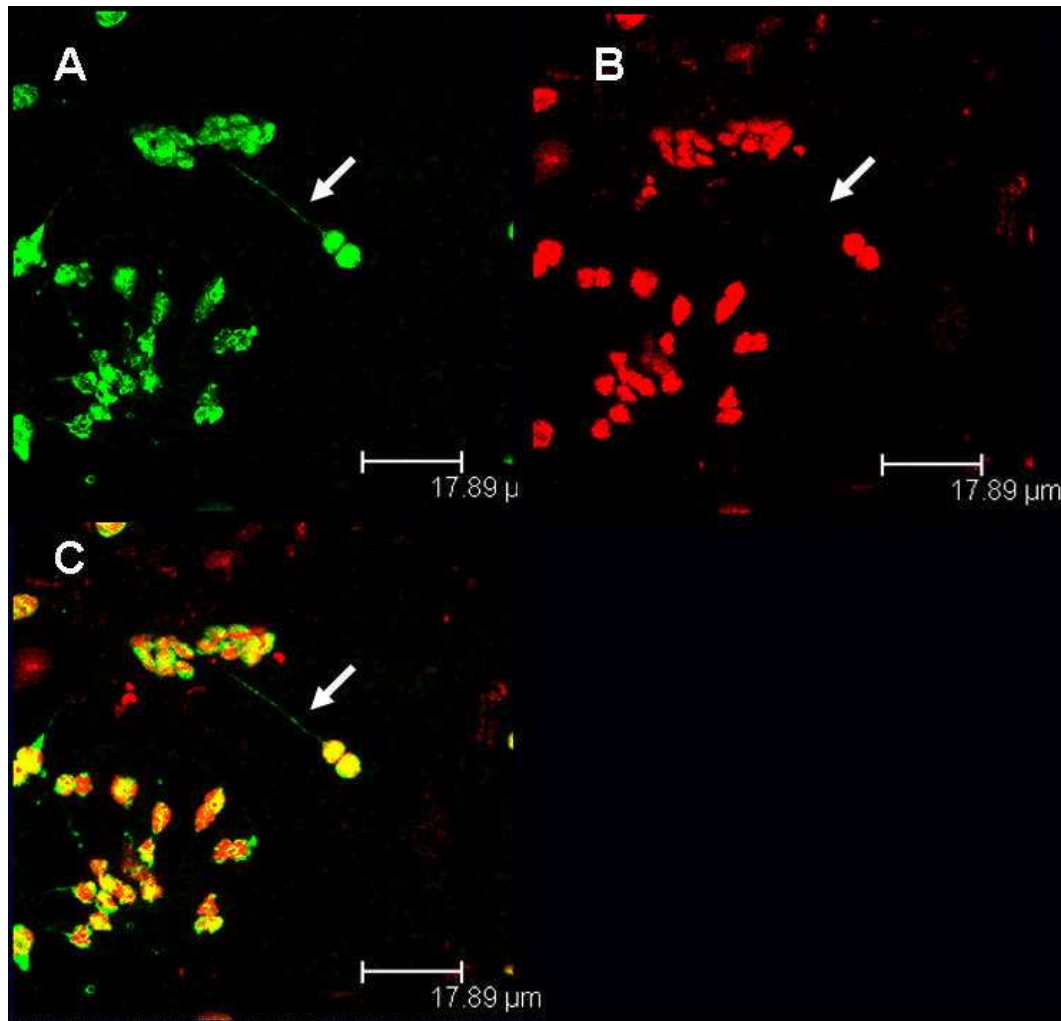

Figure 3.18: IntCR242 in the stromule of the transgenic tobacco cells

The IntCR242-GFP fluorescence was observed in the stromule (indicated by the arrow) in a hypocotyl cell. There is no red chlorophyll in the stromule that could generate red auto-fluorescence, thus the tubular stromule remain green in the over-lapping image while the chloroplasts show up as a yellow colour. The scale bar is 17.89 μm .

A: IntCR242-EGFP image

B: The chlorophyll red auto-fluorescence image

C: Superimposed image of A and B

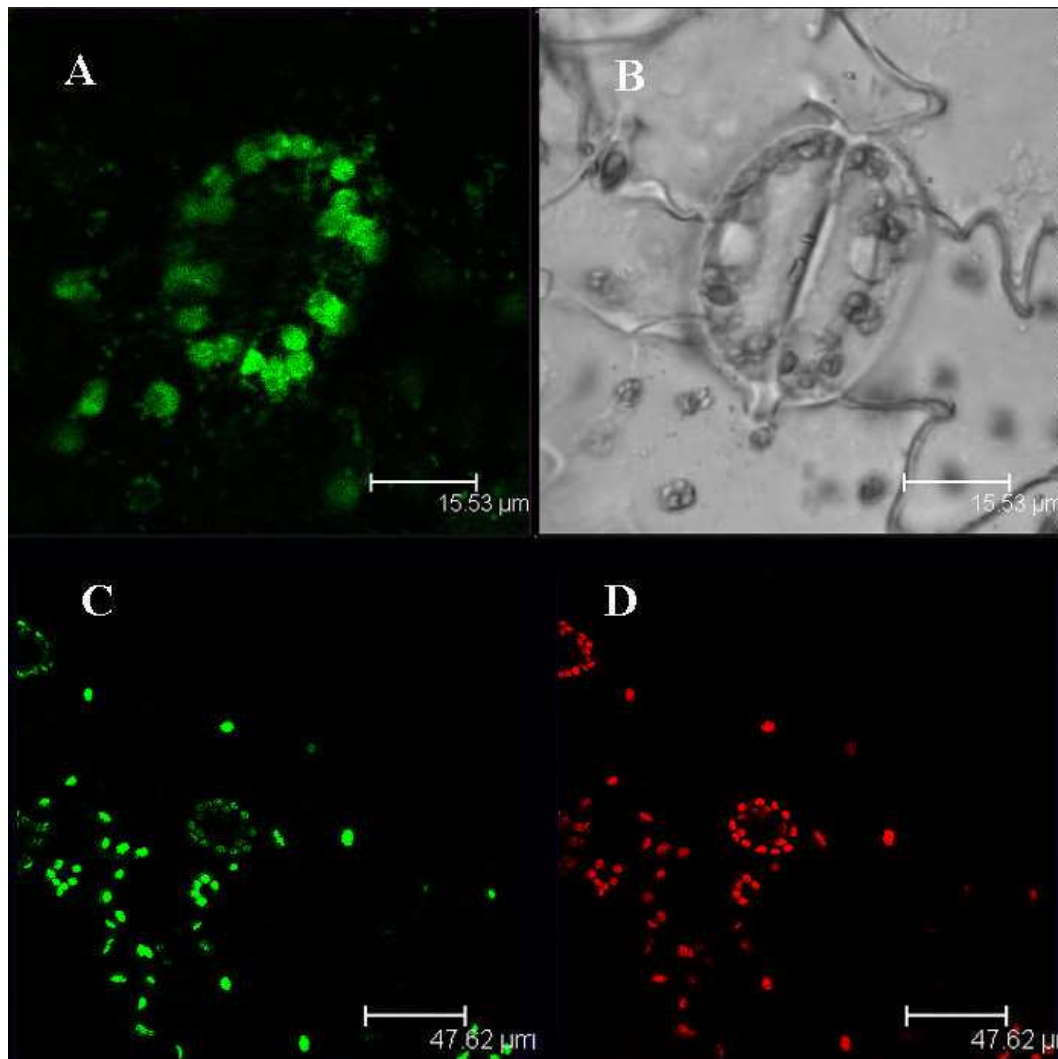

Figure 3.19: Localization of AT1G15730 and IntCR266 in transgenic tobacco

The *Arabidopsis* homologue (AT1G15730) of IntCR242 was expressed in tobacco with the EGFP fusion tag. The AT1G15730-GFP protein was targeted to the chloroplasts of the guard cell and epidermal cells and highlighted the punctated structure similar to those detected from the IntCR242-EGFP transgenic plants. On the other hand, the putative thylakoid membrane bounded IntCR266-EGFP was only observed in the chloroplast.

- A: GFP image of AT1G15730 expressed in tobacco
- B: Grey scale bright-field image of the tobacco leaf
- C: Green fluorescence image of the IntCR266-EGFP
- D: Chloroplast auto-fluorescence image

3.6.3 Cytoplasmic localization of IntCR22

The IntCR22 protein has no sub-cellular organelle targeting sequence and has been predicted to be located in the cytoplasm by PSORT as previously described (see section 3.2.3 for details). In order to study the sub-cellular localization of IntCR22, tobacco plants were transformed with construct expressing the recombinant IntCR22 protein fused to GFP and three transgenic lines have been generated (referred to as IntCR22-EGFP lines).

When the IntCR22 protein fused to EGFP tag was expressed in transgenic tobacco, the green fluorescence was found predominantly in the cytoplasm and nucleus of the leaf epidermal cells and the guard cells (Figure 3.20).

The *Arabidopsis* protein AT2G36780, which is a putative homologue of IntCR22, was cloned into binary vector pK7FWG2 and subsequently used for generating transgenic tobacco as previously described (Section 2.3.2). The AT2G36780-EGFP protein was located in the cytoplasm and nucleus as was found for the IntCR22-EGFP images (Figure 3.21).

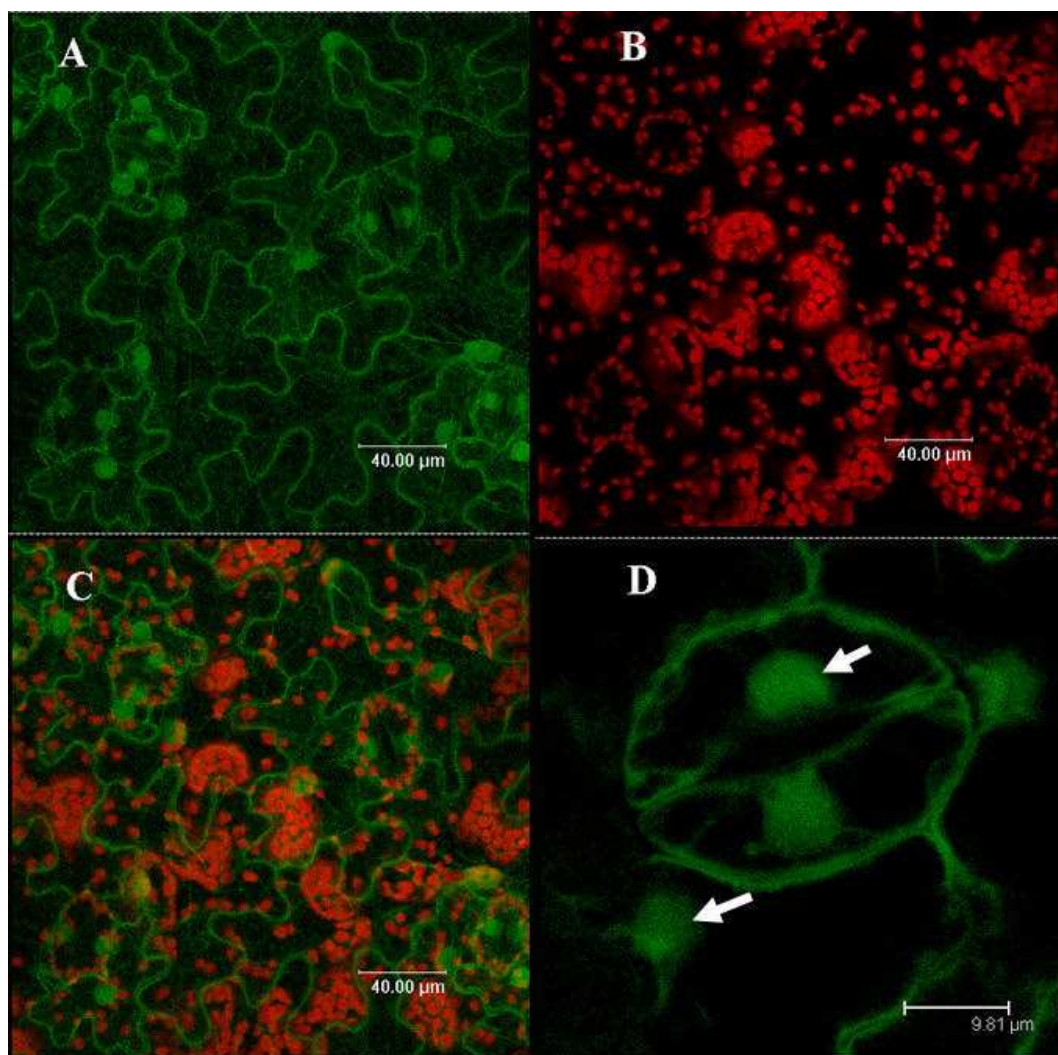

Figure 3.20: Localization of IntCR22-EGFP

Confocal scanning fluorescence microscope images of IntCR22-EGFP expressed in tobacco epidermal cells showed the IntCR22-EGFP was targeted to the nucleus and the cytoplasm. The nucleus of a guard cell and an epidermal cell are indicated by the arrow in image D.

A): GFP fluorescence image

B) Chlorophyll auto-fluorescence

C) GFP image (green) superimposed on the chlorophyll auto-fluorescence (red)

D): Zoom in image of the guard cell.

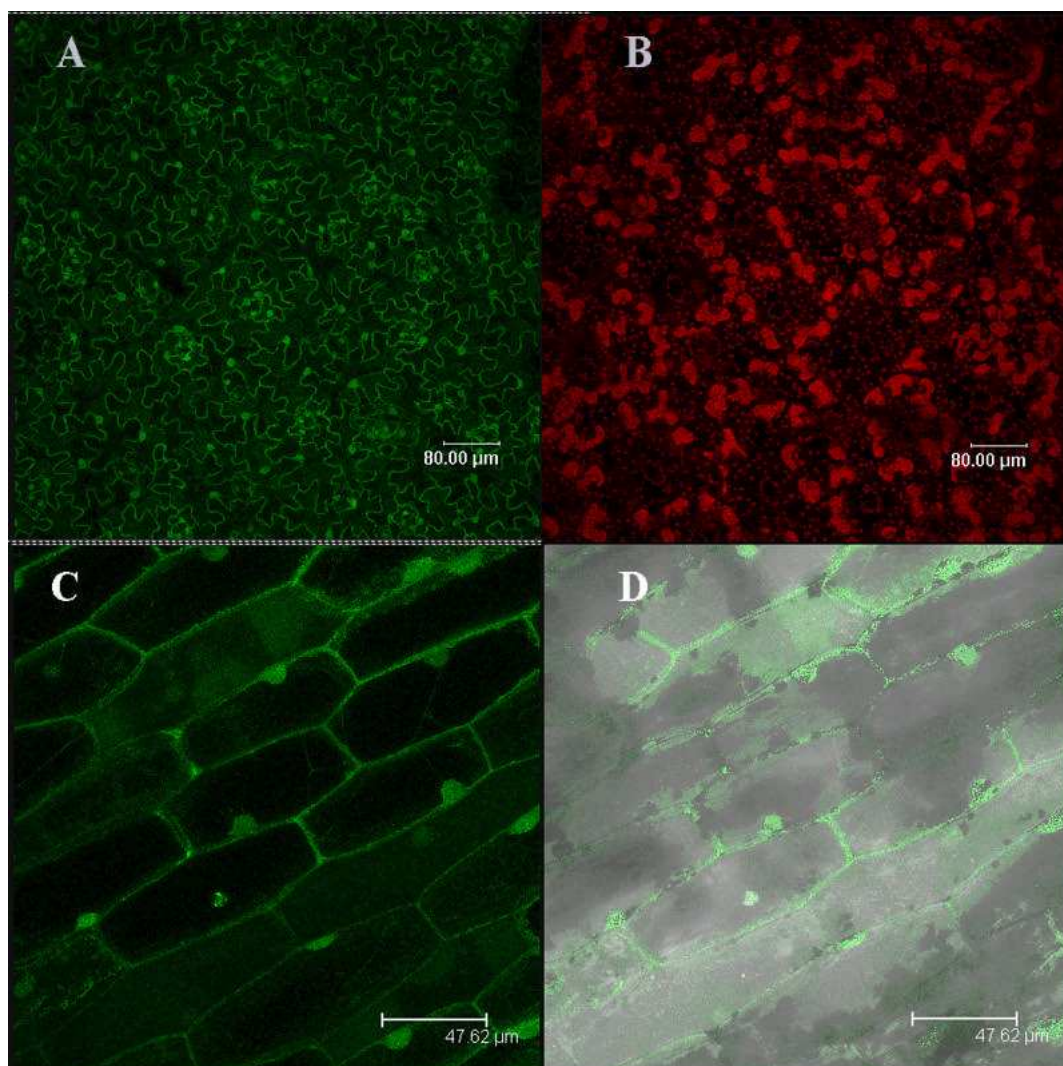

Figure 3.21: Localization of AT2G36780-EGFP

Confocal image of the transgenic tobacco leaf epidermal cells expressing the AT2G36780-EGFP construct.

- A) GFP image of the epidermal cell layer
- B) Chlorophyll auto-fluorescence image
- C) GFP image of the tobacco seedling hypocotyl cells
- D) GFP image C superimposed on the bright-field image

3.7 Localization of LeCTR2 and LeETR1

Since the *Arabidopsis* ethylene receptor ETR1 and CTR1 have been found in the ER membrane (Chen *et al.*, 2002; Gao *et al.*, 2003), it was surprising that two of the IntCR proteins (IntCR242 and IntCR266) contained chloroplast transit peptide (cTP) and were localized to the chloroplast (Figure 3.17-3.19). It is difficult to reconcile these findings with the results of the yeast two-hybrid assay that IntCR proteins could associate with the putative ER membrane-bounded LeETR1 (Figure 3.11). Therefore, the sub-cellular localization of the tomato ethylene receptors and CTRs needs to be investigated. However, it has been reported that transient expression of the *Arabidopsis* ETR1-GFP protein using a strong 35S CaMV promoter in *Arabidopsis* protoplast produced an excess of protein aggregation and impaired the visualization of GFP (Chen *et al.*, 2002). In addition, the attempts to visualize AtETR1-GFP using the endogenous *AtETR1* promoter was also unsuccessful possibly due to the insufficient fluorescent signal (Chen *et al.*, 2002). In this study, efforts to transform tobacco with the construct containing 35S::LeETR1::EGFP were unsuccessful (data not shown), which is in agreement with the aforementioned *Arabidopsis* experiments that over-expressing ethylene receptor in transgenic plants is unlikely to succeed. Furthermore, attempts to express and visualize the LeCTR2-GFP using the CaMV 35S promoter were also unsuccessful, possibly due to the toxicity effects caused by over-expressing a MAPKK kinase (data not shown). Thus, fragments of LeETR1 and LeCTR2 fused to EGFP were expressed in order to circumvent the adverse effects caused by over-expressing the full-length proteins.

3.7.1 Cytoplasmic localization of LeCTR2 and AtEDR1

Two of the IntCR proteins (Interacting with CTR2) have chloroplast transit peptide (cTP) and were targeted to the chloroplast when expressed in tobacco (Section 3.6). A putative cTP was also found in the N-terminus of CTR2 by the localization prediction software ChloroP. However, the prediction results obtained from ChloroP and PSORT (<http://www.expasy.org>) are conflicting (Table 3.2). As chloroplast proteins generally contain an N-terminal cTP that is less than 100 amino acid in length, to test whether LeCTR2 is a chloroplast protein, the cDNA encoding the N-terminus of LeCTR2 (aa 1-98) was PCR amplified, cloned into the binary vector pK7FWG2, in which the LeCTR2¹⁻⁹⁸ DNA sequence is fused in frame to EGFP. It was reasoned that if the N-terminal fragment of LeCTR2 could target the GFP to the chloroplast, the full-length LeCTR2 is likely to be a chloroplast-localized protein.

The confocal image of the GFP fluorescence in the 35S::LeCTR2¹⁻⁹⁸::EGFP transgenic tobacco cells showed that the LeCTR2¹⁻⁹⁸::EGFP fusion protein was located in the cytoplasm and nucleus, which could not co-localize with the red chlorophyll auto-fluorescence of the chloroplast (Figure 3.22, 3.23 and 3.24). This suggests that the LeCTR2¹⁻⁹⁸ is not a functional chloroplast transit peptide in tobacco. Furthermore, the LeCTR21¹⁻⁹⁸ also failed to target GFP to mitochondrion. Therefore, the full-length LeCTR2 protein is not likely to be targeted to chloroplast/mitochondrion and might not be able to interact with the chloroplast IntCR proteins (IntCR242 and IntCR266) in the plant cell.

The *Arabidopsis* gene *EDR1* (AT1G08720, *Enhanced Disease Response1*) shares sequence homology to the tomato *CTR2* as previously discussed (see section 1.3.3 for details). The protein localization of EDR1 was then investigated by generating transgenic tobacco plants expressing EDR1 protein fused to GFP. The cDNA encoding N-terminus of EDR1 (aa 1 to 605) obtained from RT-PCR was cloned into plasmid pK7FWG2 (referred to as construct EDR1-GFP; Figure 3.25). One transgenic tobacco plant was generated expressing EDR1-GFP. The confocal microscope images of the transgenic tobacco leaf epidermal cells indicated that EDR1¹⁻⁶⁰⁵-GFP was predominantly localized in the cytoplasm and nucleus but not in the chloroplasts (Figure 3.25). This is identical to the localization of the LeCTR2¹⁻⁹⁸-EGFP.

Table 3.2: Software prediction of the LeCTR2 localization

Software	Chloroplast localization score/reliability	cTP
ChloroP	0.588	67 aa
PSORT	Mitochondria 7; Nucleus 4; Chloroplast 2	N/A

The software ChlroP generates a score ranging from 0 to 1 for each protein entry. The higher the score, the more likelihood the protein would be targeted to the chloroplast. On the other hand the prediction program PSORT lists possibilities of the protein sub-cellular localization and assigns a value to each prediction (the higher the value, the more reliable the prediction). ChloroP predicted that LeCTR2 is a chloroplast protein with a 67 amino acid cTP, whilst PSORT considers LeCTR2 is more likely to be targeted to mitochondria or nucleus than to the chloroplast. cTP: Chloroplast transit peptide.

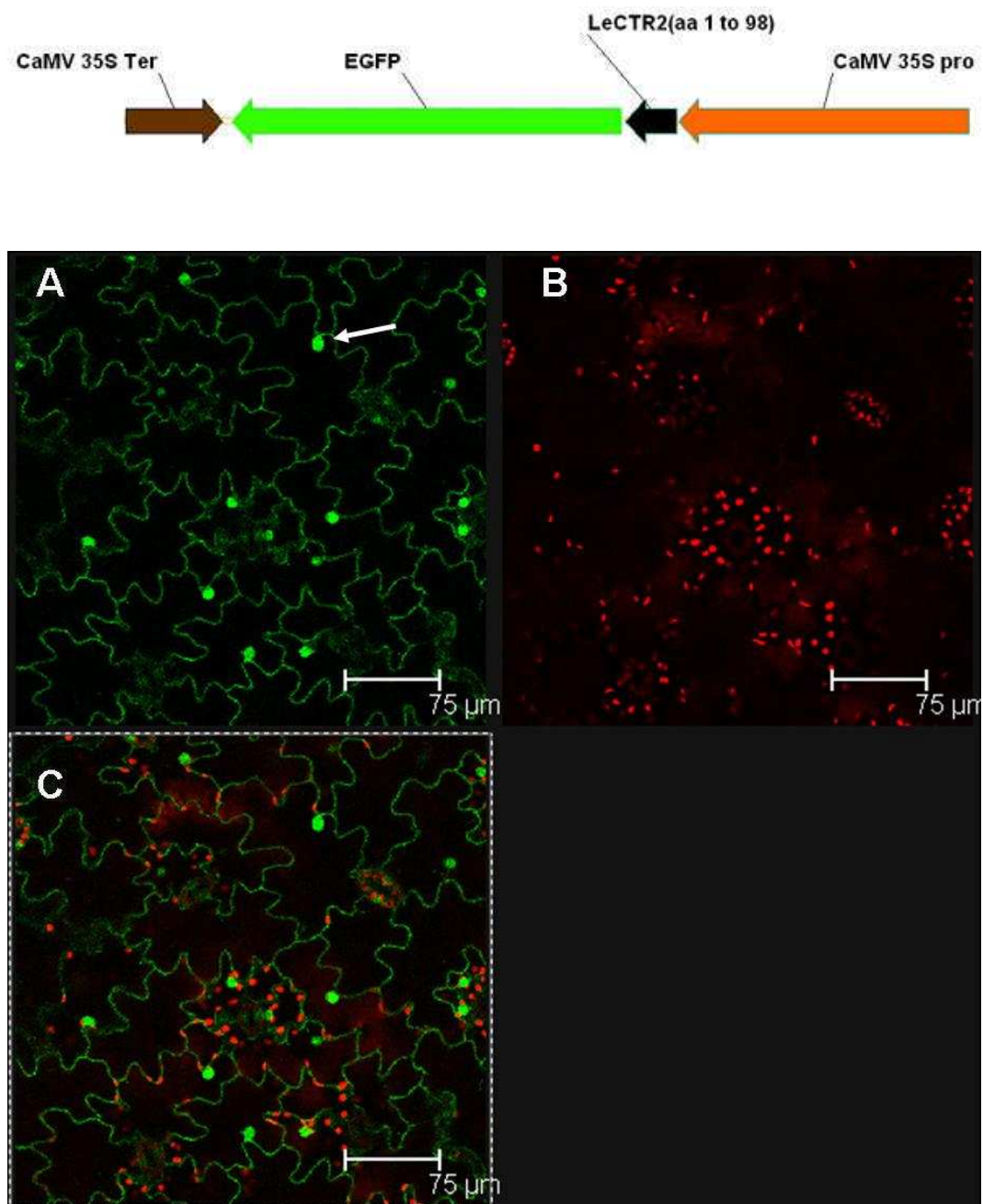

Figure 3.22: LeCTR2¹⁻⁹⁸-EGFP localized to the cytoplasm and nucleus

The confocal image of transgenic tobacco leaf epidermal cells expressing the first 98 amino acid residues of LeCTR2 fused to EGFP under the control of the CaV35S promoter. The schematic diagram of the construct was shown above.

- A) The LeCTR2¹⁻⁹⁸-EGFP was targeted to the nucleus (arrow) and the cytoplasm.
- B) The red chlorophyll auto-fluorescence marked the position of the chloroplasts.
- C) Superimposed image of A and B showing that GFP was not targeted to the chloroplast.

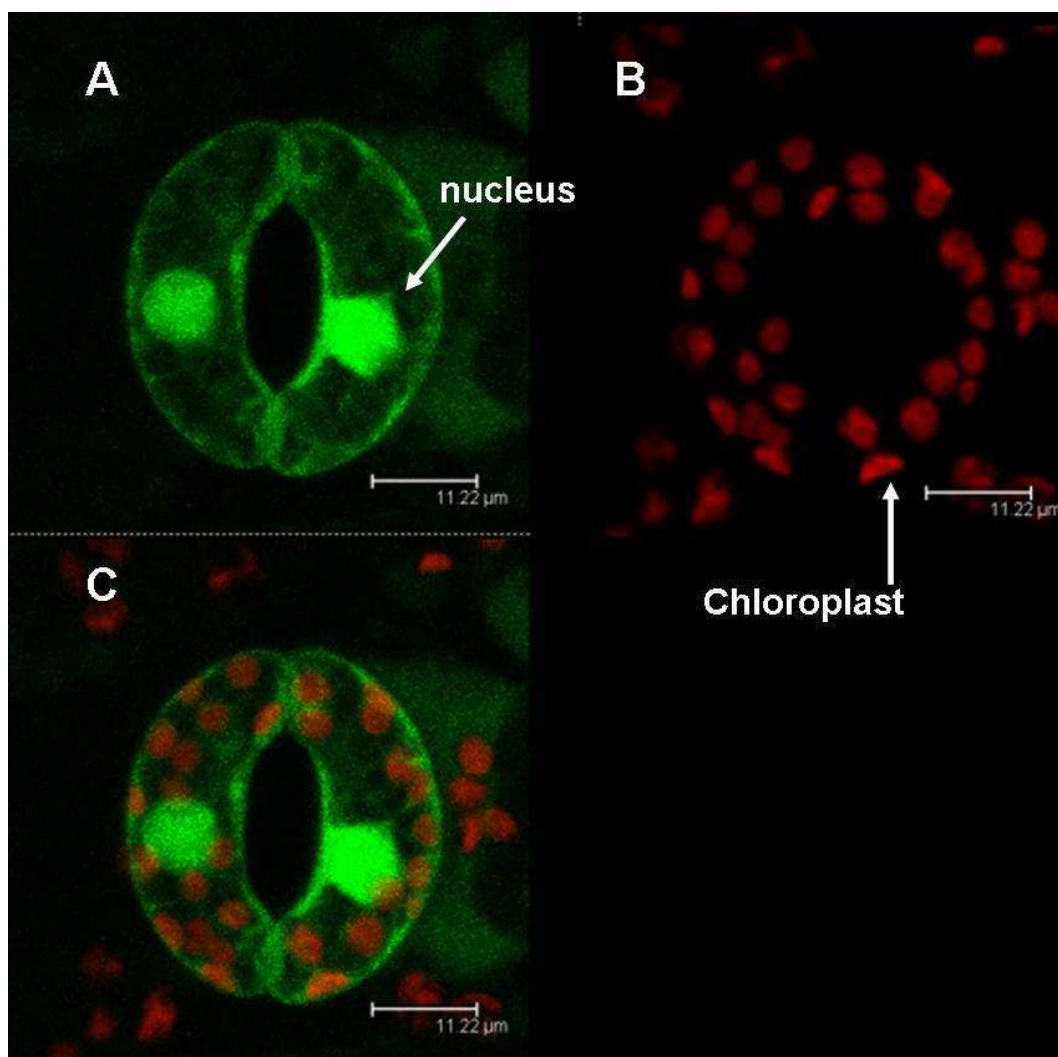

Figure 3.23: Localization of LeCTR2¹⁻⁹⁸-GFP in the guard cells

The confocal image of guard cells expressing the LeCTR2¹⁻⁹⁸-GFP construct showed that the GFP signal is predominantly located in the cytoplasm and nucleus. The red auto-fluorescence of the guard cell chloroplast did not co-localize with the GFP signal. This suggested that LeCTR2 is unlikely to be targeted to the chloroplast as IntCR242 and 266.

- A) GFP image
- B) Chlorophyll auto-fluorescence
- C) Overlay image of A and B.

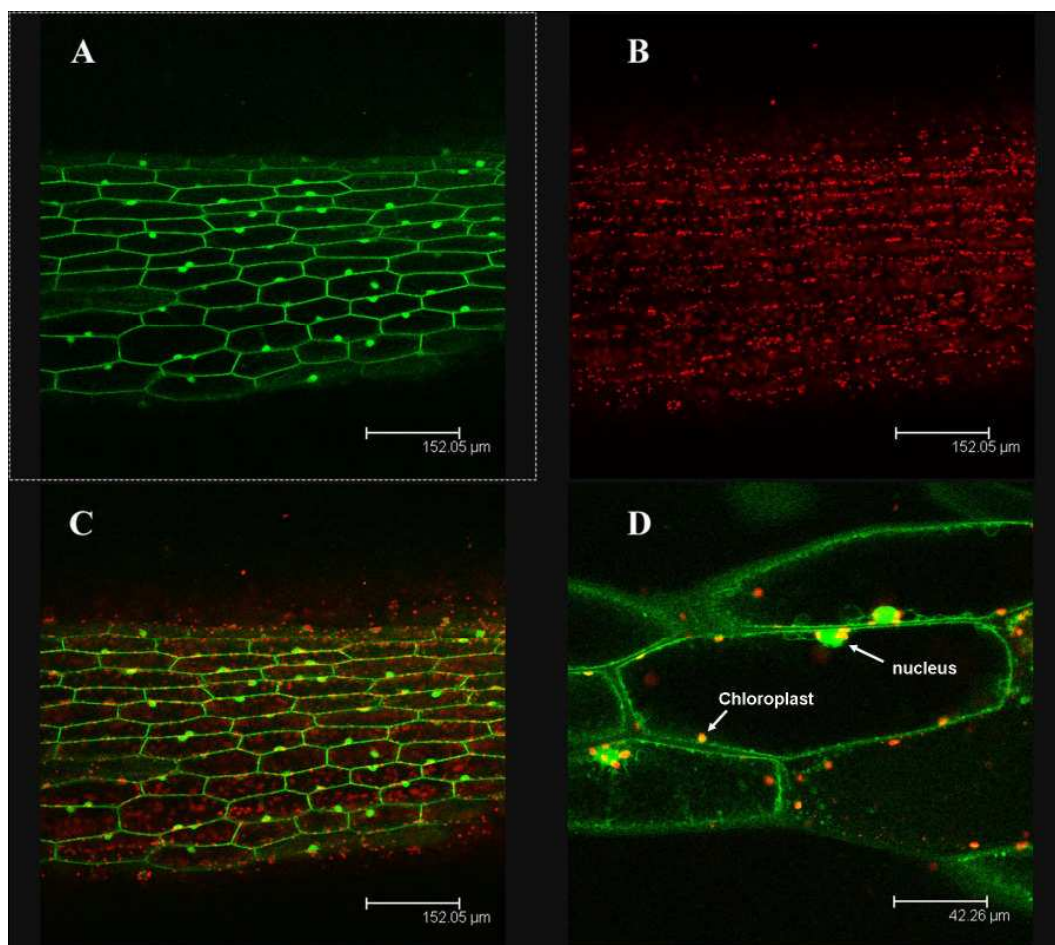

Figure 3.24: Localization of LeCTR2¹⁻⁹⁸-GFP in hypocotyl cells

The confocal image was taken from the transgenic tobacco hypocotyl cells expressing the LeCTR2¹⁻⁹⁸-GFP construct. The green fluorescence is predominantly localized in the cytoplasm and the nucleus but not in the chloroplasts.

- A) GFP image
- B) Chlorophyll red auto-fluorescence
- C) Superimposed image of A and B
- D) Zoom in image (GFP superimposed on the red chlorophyll fluorescence)

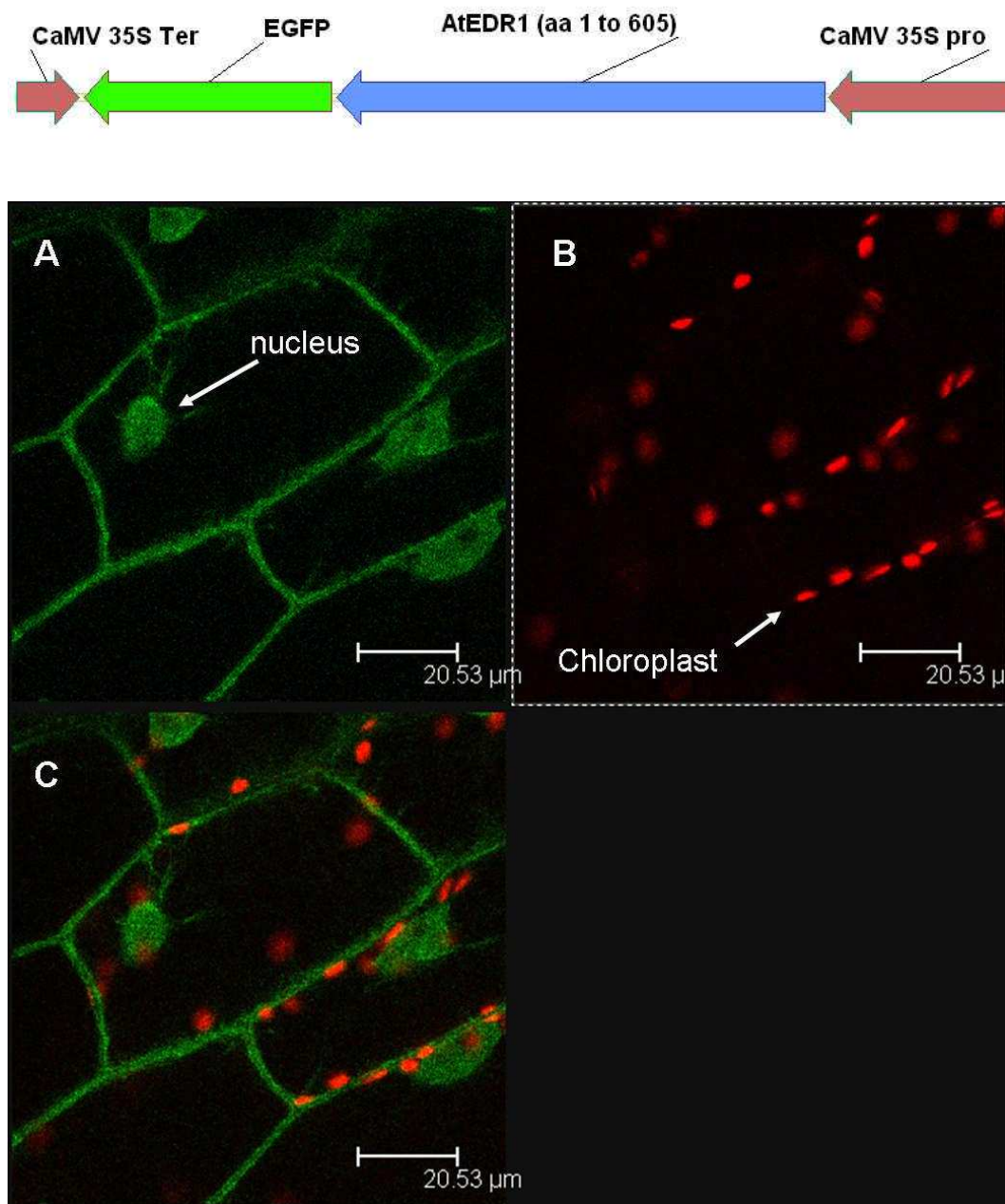

Figure 3.25: AtEDR1¹⁻⁶⁰⁵ was located to the cytoplasm and nucleus

The confocal image was taken from the transgenic tobacco hypocotyl cells expressing AtEDR1¹⁻⁶⁰⁵-EGFP under the control of the CaMV35S promoter. The schematic diagram of the construct was shown above. The localization of the green fluorescence is similar to those of the LeCTR2¹⁻⁹⁸-EGFP transgenic plants.

- A) GFP image
- B) Chlorophyll red auto-fluorescence
- C) Superimposed image

3.7.2 LeETR1 is located to the ER

In order to identify the cellular localization of the putative downstream kinase LeCTR2 and to circumvent the adverse effects caused by over-expressing, a construct expressing only the N-terminal fragment of LeCTR2 fused to EGFP was used to transform tobacco (Figure 3.22-3.24). However, this strategy was unsuccessful when it was applied to visualize the N-terminus of LeETR1 fused to EGFP (referred to as LeETR1¹⁻¹³⁷-EGFP) in tobacco (data not shown). Thus a transient protein expression system based on biolistic delivery of the DNA-coated gold particles to the onion epidermal cells has been used to express the target protein of interest.

The LeETR1¹⁻¹³⁷-EGFP construct was transiently expressed in the onion epidermal cells as previously described (Section 2.15.2). Confocal images showed that the LeETR1¹⁻¹³⁷-EGFP was predominantly localized to the cortical ER network (Figure 3.26 A). The tomato *EIN2* encodes an integral membrane protein and acts genetically downstream the ethylene receptor and CTR. When transiently expressed in onion cells, the LeEIN2-GFP fluorescence was also found in the ER network (Figure 3.26 B). The *Arabidopsis* gene *STL12P* (AT2G01470), which encodes a SEC12-like ER membrane protein, was used as the ER marker for the biolistic experiment as recommended in Hanton and Brandizzi (2006). YFP (Venus) fused to the pumpkin 2S albumin ER targeting sequence and the ER retention sequence (HDEL) was also used as ER control. When expressed in onion cell, both constructs (Sec12-CFP and YFP-HDEL) highlighted the cortical ER network as expected (Figure 3.26 C and D).

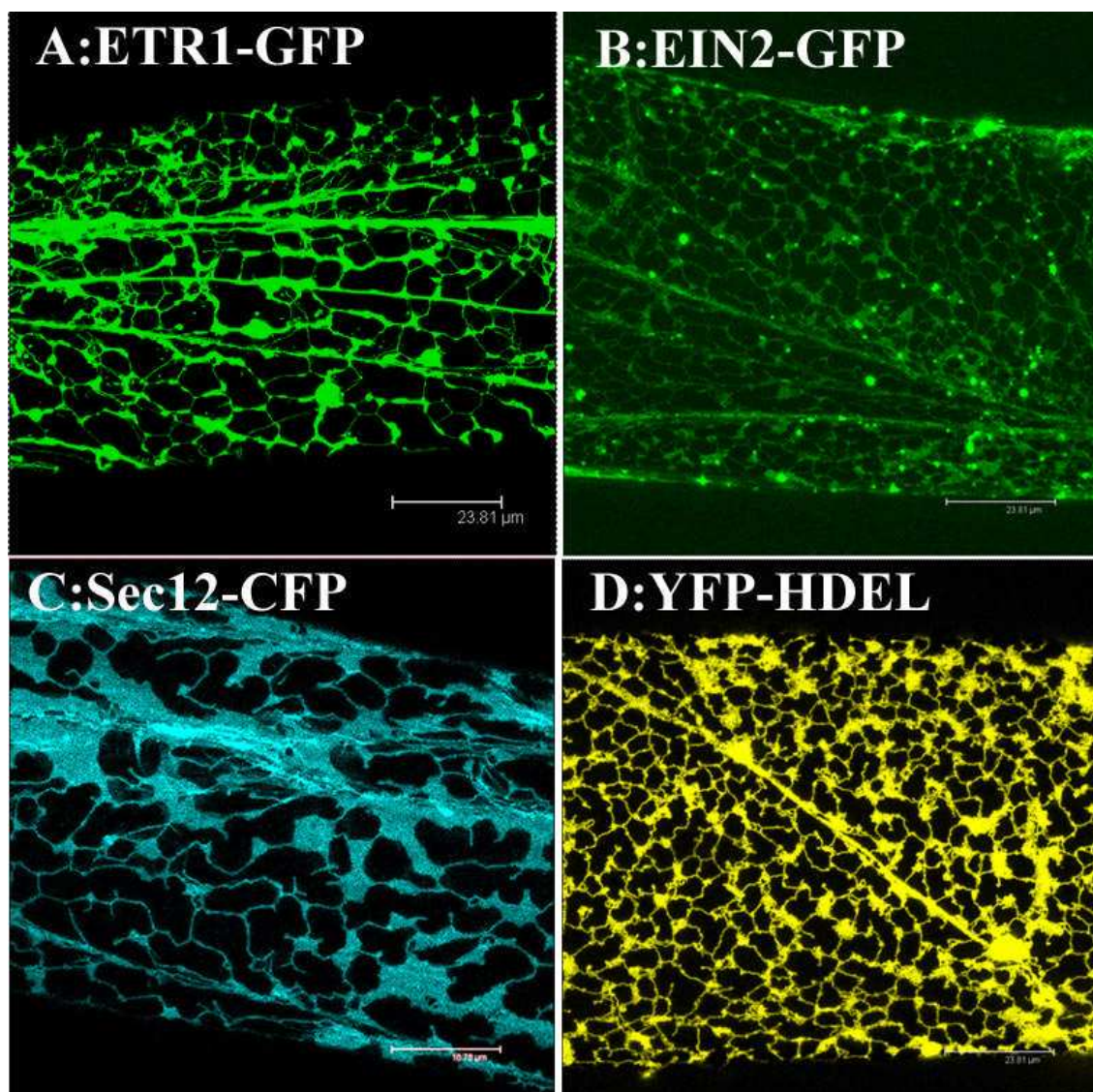

Figure 3.26: LeETR1 and LeEIN2 were targeted to the ER

Recombinant proteins fused to fluorescent protein were transiently expressed in onion epidermal cell as previously described (Section 2.15.2). The images were acquired using the confocal scanning microscope 12-14 h after the transformation.

A: LeETR1¹⁻¹³⁷-GFP

B: LeEIN2-GFP

C: *Arabidopsis* ER membrane protein Sec12 (AT2G01470) fused to CFP

D: YFP targeted to ER lumen

3.7.3 IntCR22 co-localized but showed no FRET with LeCTR2

The IntCR242 and IntCR266 proteins were targeted to the chloroplasts, whereas IntCR22 was localized in the cytoplasm and nucleus while expressed in transgenic tobacco (see section 3.6 for details). On the other hand, LeCTR2 was found in the cytoplasm when transiently expressed in onion epidermal cells (Figure 3.27). Although IntCR242 and IntCR266 showed protein-protein interaction with LeCTR2 in the yeast two-hybrid assay (Lin *et al.*, 2003), it is unlikely that this association could take place in the plant cell, if they were targeted to different sub-cellular organelles. It appears that only IntCR22 could interact with LeCTR2 as both of them could be found in the cytoplasm and nucleus.

In order to study the localization and *in vivo* interaction between LeCTR2 and IntCR22 proteins, they were co-expressed in an onion epidermal cell and FRET experiment was performed. The IntCR22-CFP and LeCTR2-YFP indeed co-localized in the cytoplasm and nucleus when simultaneously expressed in onion (Figure 3.27). However, no Forster resonance energy transfer was observed between IntCR22-CFP and LeCTR2¹⁻⁶⁷⁸-YFP (Figure 3.28). On the other hand, the FRET positive control, which is a construct expressing the YFP fused to CFP, showed 21% FRET efficiency (Figure 3.29). These observations suggest that LeCTR2 might not be able to interact with IntCR22 *in vivo*. However, lack of FRET could not rule out the possibility that LeCTR2 and IntCR22 might interact with each other but have adopted a non-favourable orientation or distance that prevents FRET from taking place.

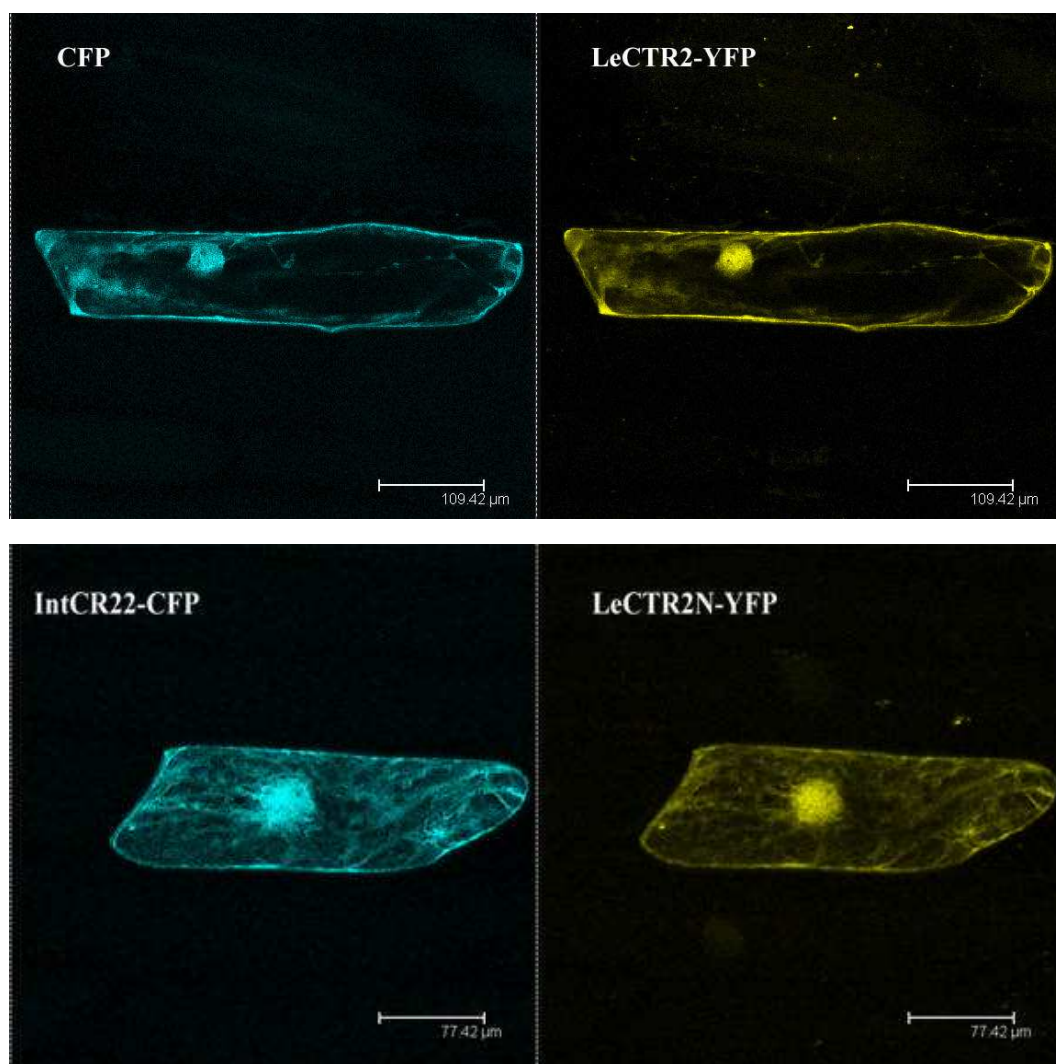

Figure 3.27: Co-localization of LeCTR2 with IntCR22

The fluorescence from CFP (cyan image left) and YFP (yellow image right) co-localized in the cytoplasm and nucleus in an onion cell co-expressing CFP and LeCTR2¹⁻⁶⁷⁸-YFP (top), as well as the cell co-expressing IntCR22-CFP and LeCTR2¹⁻⁶⁷⁸-YFP (bottom).

Top: Onion epidermal cell expressing LeCTR2-YFP and CFP

Bottom: Onion epidermal cell expressing LeCTR2-YFP and IntCR22-CFP

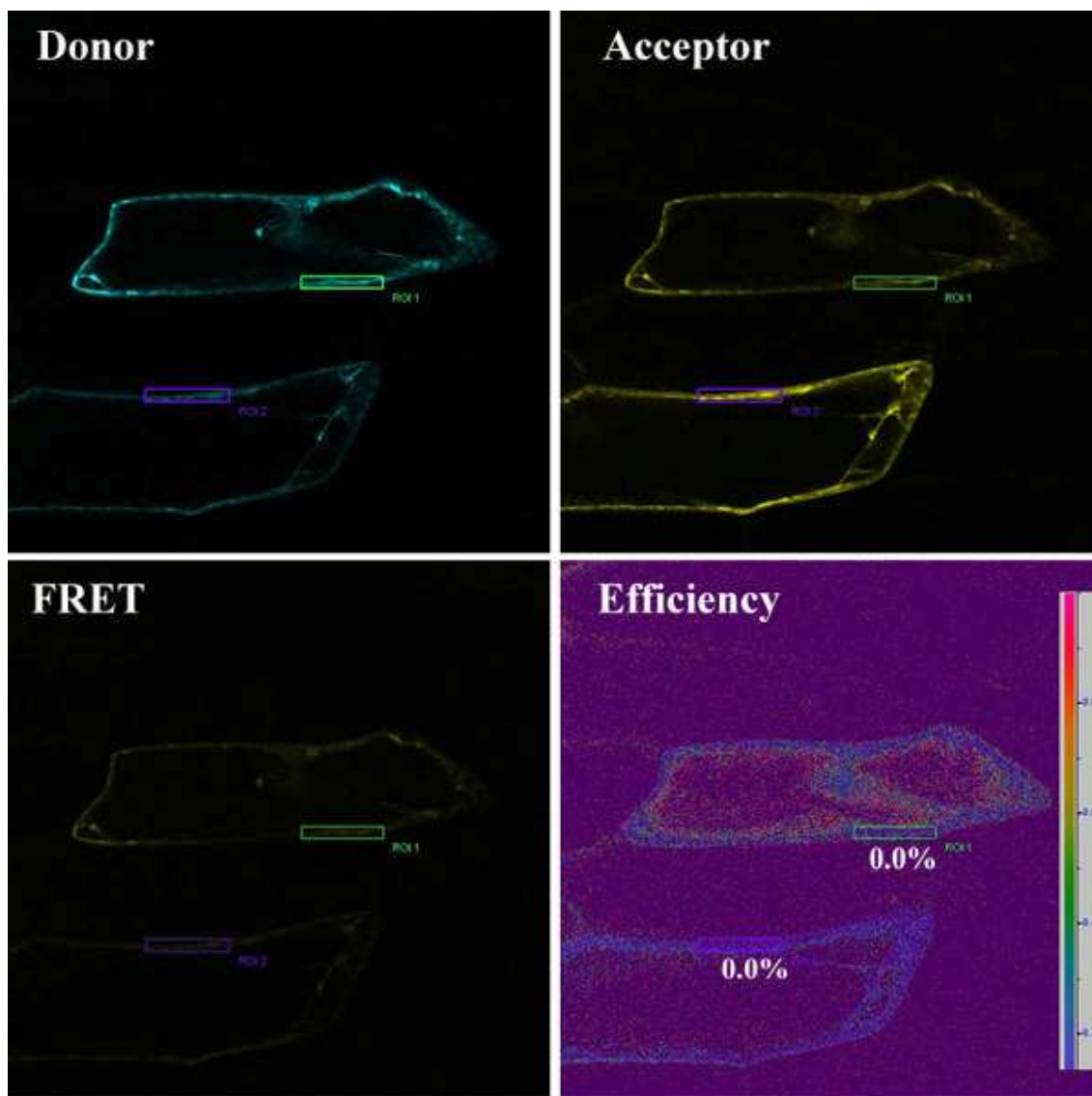

Figure 3.28: No FRET between IntCR22 and LeCTR2

The IntCR22-CFP (donor) and LeCTR2⁶⁷⁸-YFP (acceptor) were co-expressed in the onion epidermal cells. The FRET efficiency is 0% in the two ROIs (region of interest, indicated as rectangles in the images). The FRET and efficiency image were generated by the LCS as previously described in the method section.

Donor: signal from CFP donor channel when excited with 458 nm laser

Acceptor: signal from YFP channel when excited with 514 nm laser

FRET: signal from YFP when excited with 458 nm laser

Efficiency: the FRET efficiency calculated by LCS

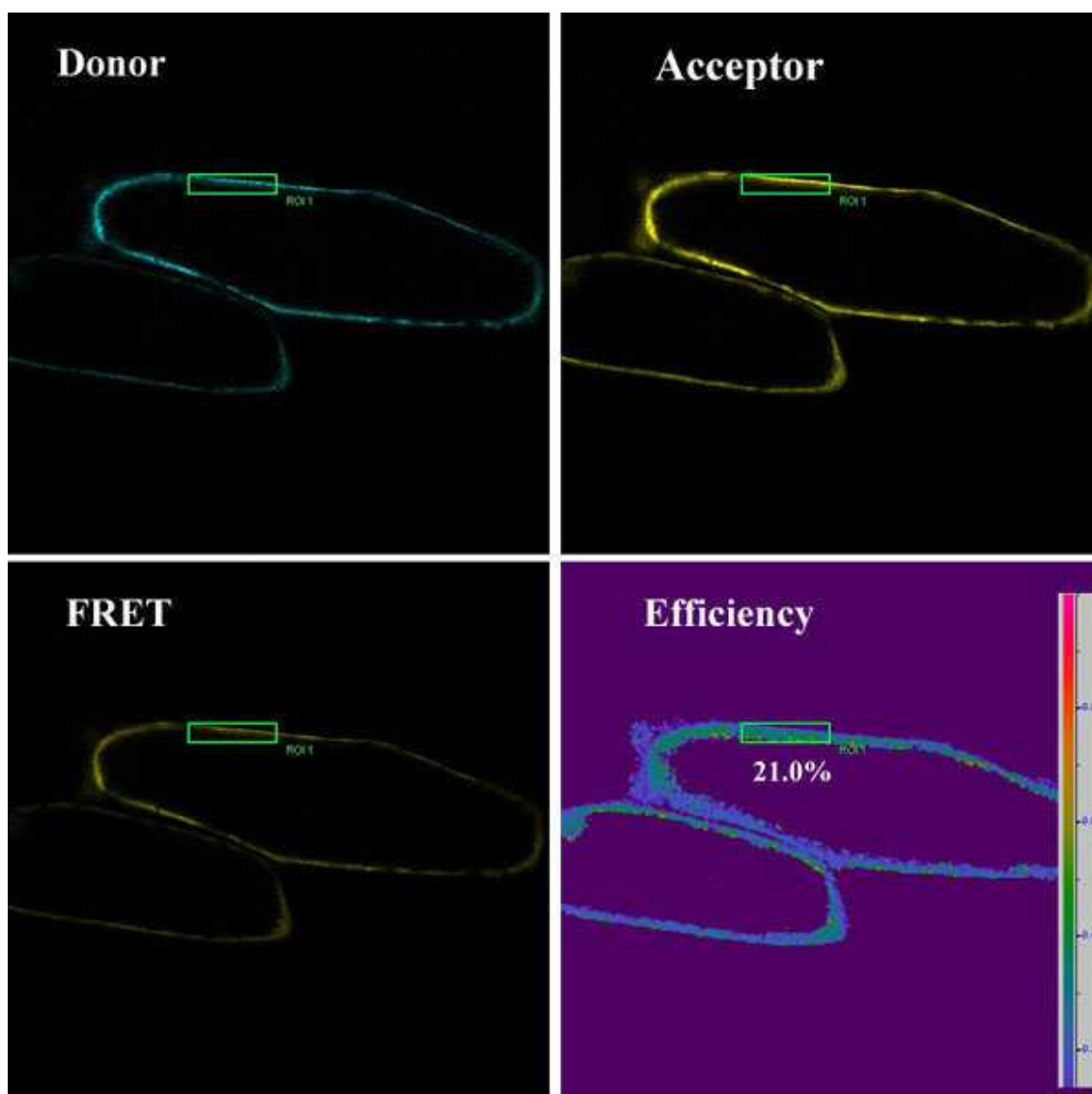

Figure 3.29: FRET positive control

The FRET positive control plasmid (YFP fused to CFP) was expressed in an onion epidermal cell. In the region of interest (indicated by the green rectangle), the FRET efficiency is 21%. The FRET and efficiency image were generated by the LCS as previously described in the method section.

Donor: signal from CFP donor channel when excited with 458 nm laser

Acceptor: signal from YFP channel when excited with 514 nm laser

FRET: signal from YFP when excited with 458 nm laser

Efficiency: the FRET efficiency calculated by LCS

3.8 Re-examination of the Protein-Protein Interactions

Evidence from previous protein localization experiments using either stable transgenic plants or transient expression suggested that the ethylene receptor LeETR1 was targeted to the ER membrane (Figure 3.26), the putative downstream kinase LeCTR2 was localized to the cytoplasm and nucleus (Figure 3.27), whilst two of the IntCR proteins (242 and 266) were found in the chloroplast (Figure 3.17-3.19). However, the yeast two-hybrid assay indicated that the ER localized LeETR1 could associate with the cytoplasmic LeCTR2 (Lin *et al.*, 2003). Furthermore, the chloroplast protein IntCR242 and IntCR266 are also capable to interact with LeETR1 and LeCTR2 in yeast (Figure 3.11; Lin *et al.*, 2003).

This presents an anomaly, since the *in vivo* protein-protein interaction could not take place if the interacting proteins were targeted to different sub-cellular locations inside the plant cell. Thus, further yeast two-hybrid experiments and protein interaction studies were carried out to test the significance of the interaction between the tomato ethylene receptors and the downstream LeCTRs.

3.8.1 The G238E mutated LeCTR2

Evidence from the yeast two-hybrid and immuno-localization experiments suggested that the *Arabidopsis* Ser/Thr kinase CTR1 could interact with the ethylene receptors

(Clark *et al.*, 1998; Gao *et al.*, 2003). It has also been reported that the Gly³⁵⁴ to Glu mutation in the CN (CTR1 N-terminal) motif of the *Arabidopsis* CTR1 protein abolished its interaction with the ethylene receptors AtETR1 and AtERS1 (Huang *et al.*, 2003). The authors also showed that the CN motif is conserved in all identified CTRs, and it is also found in the tomato CTR2. Therefore it was hypothesized that if LeCTR2 associates with LeETR1 in a manner similar to that of the *Arabidopsis* CTR1-ETR1 interaction, the LeCTR2 protein would lose its interaction with the tomato ethylene receptor LeETR1, when a Gly to Glu mutation is incorporated into the LeCTR2 CN motif.

In order to introduce the corresponding Gly to Glu change into the coding sequence (CDS) of LeCTR2, mutation PCR was carried out using a forward primer containing a mismatch nucleotide (GGG to GAG). As the forward primer also incorporates a *Bam*HI site, the PCR product was digested with *Bam*HI and cloned back into the LeCTR2 CDS in the pENTR plasmid (Figure 3.30). The cDNA fragment encoding the mutated LeCTR2⁸⁰⁻⁶⁷⁸ was subsequently cloned into the yeast two-hybrid prey plasmid pJG4-5. The interaction between the mutated LeCTR2 and the ethylene receptors (LeETR1, LeETR2 and NR) was then examined using the LexA-based yeast two-hybrid system as previously described (Section 2.13.2).

Detection of protein-protein interaction in the yeast two-hybrid system is based on two reporter genes: *LacZ*, which generates blue colour in the presence of X-Gal; *LEU*,

which confers yeast growth in the absence of leucine. Yeast transformed with ethylene receptor (LeETR1 or LeETR2) and LeCTR2 (non-mutated) activated both reporter genes as indicated by the blue colour in the filter lift assay and the presence of yeast growth on medium lacking leucine (Figure 3.31). This suggests that the non-mutated LeCTR2 can interact with the ethylene receptors (ETR1 and ETR2) in the yeast two-hybrid assay, which is consistent with the previous yeast two-hybrid results (Lin and Grierson, unpublished data).

However, the G283E mutated LeCTR2 protein (referred to as LeCTR2m) retained its protein-protein interaction with the tomato ethylene receptor ETR1 and ETR2 (Figure 3.31). In addition, both the wild-type and mutated LeCTR2 could not interact with the ethylene receptor NR (Figure 3.31), which is again in agreement with the previous yeast two-hybrid studies that LeCTR2 has no association with NR (Lin and Grierson, unpublished data).

Collectively, the results of the mutation yeast two-hybrid assay suggests that the Gly²⁸³ to Glu mutation in the conserved CN motif of LeCTR2 has no effect on its interaction with the tomato ethylene receptors (ETR1 and ETR2) in the yeast two-hybrid assay (LexA-based yeast two-hybrid system).

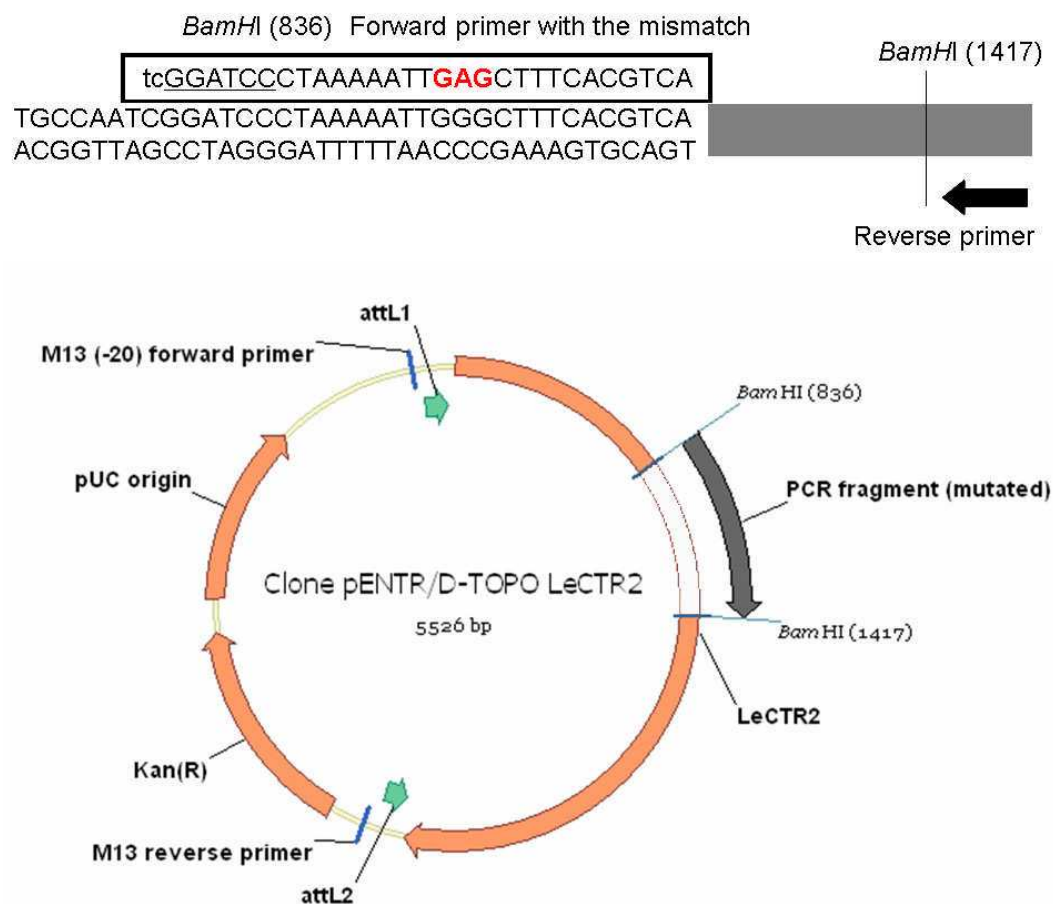

Figure 3.30: PCR mutation (Gly²⁸³ to Glu) of the CN motif in LeCTR2

PCR was performed using a forward primer with a G to A mutation and a gene specific reverse primer in order to incorporate the Gly²³⁸ to Glu mutation into LeCTR2. The PCR product was then digested with *Bam*HI and cloned into *Bam*HI linearized LeCTR2-pENTR plasmid. The PCR primer with the mutation (GGG to GAG) was shown in the rectangle. The *Bam*HI site in the forward primer was underlined.

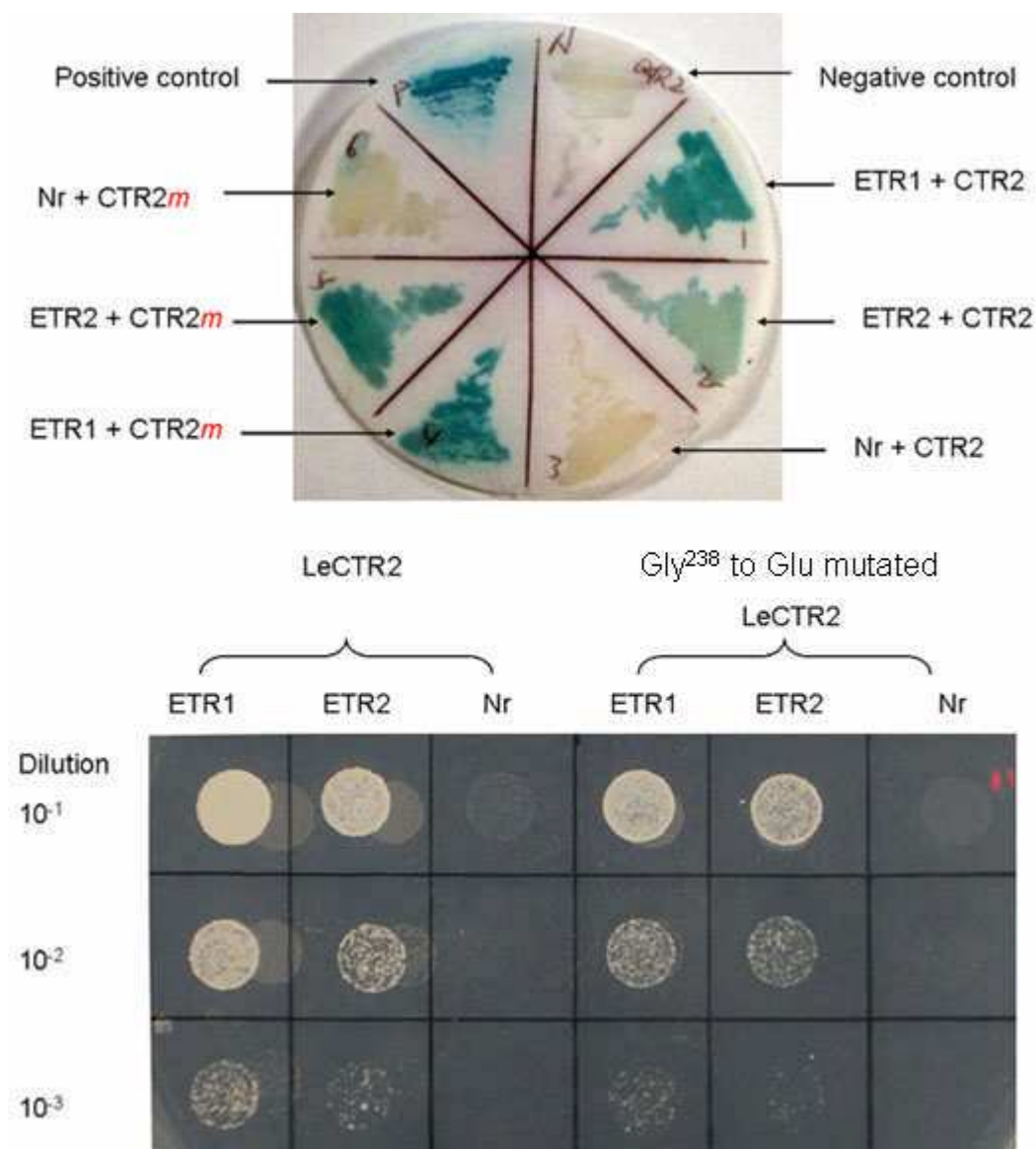

Figure 3.31: Gly²³⁸ to Glu mutated LeCTR2 in the yeast two hybrid-assay

Yeast two-hybrid assay was carried out as previously described (Section 2.13.2). The mutated LeCTR2 (referred to as CTR2_m) could still associate specifically with the ethylene receptor LeETR1 and LeETR2, but not NR. This suggests that the G238E mutation in LeCTR2's CN motif could not disrupt its association with the ethylene receptors (ETR1 and ETR2).

The blue colour in the filter lift assay shows the activation of the *lacZ* reporter gene, (top image). The growth on medium lacking leucine indicates activation of the *Leu* reporter gene (bottom image). The receptor constructs (LeETR1¹³²⁻⁷⁵⁴, LeETR2¹¹⁵⁻⁷³² and Nr¹¹⁷⁻⁶³⁵), positive/negative controls and the non-mutated LeCTR2⁸⁰⁻⁶⁷⁸ were kindly provided by Dr. Zhefeng Lin.

3.8.2 Interaction between receptors and CTRs

It appears that the G238E mutation in LeCTR2 is unable to abolish its interaction with the tomato ethylene receptors ETR1 and ETR2 in the yeast two-hybrid assay (Figure 3.31). One possibility is that the mutated Gly residue in the CN motif is not involved in the interaction of LeCTR2 with the tomato ethylene receptors. It is also possible that the mutation could reduce the strength of the protein-protein interaction, but the LexA-based yeast two-hybrid system is too sensitive to discriminate such difference. Alternatively, the interaction between LeCTR2 and the ethylene receptors might be a false positive result of the yeast two-hybrid assay. The yeast two-hybrid system based on GAL4 transcription factor is generally considered to be more stringent than the LexA ones. The *HIS* reporter gene used in the GAL4-based system also enables quantitative measurement of the strength of the protein-protein interaction. Thus, the interaction between LeCTR2 and the tomato ethylene receptors was re-examined using the GAL4-based ProQuest yeast two-hybrid system (a kind gift from Dr. Zoe Wilson, Plant Sciences Division, University of Nottingham).

In the ProQuest yeast two-hybrid system, yeast transformed with LeETR1 and LeCTR2 could not activate the reporter genes (Figure 3.32). This suggests that the interaction between LeETR1 and LeCTR2 is too weak to be detected by the ProQuest yeast two-hybrid system. It has been reported that the *Arabidopsis* ethylene receptor ETR1 could interact with AtCTR1 in the yeast two-hybrid assay (Clark *et al.*, 1998). Therefore, as a positive control experiment for the ProQuest yeast two-hybrid system, AtETR1 and

AtCTR1 were cloned by RT-PCR and their interaction was tested using the ProQuest system. It was showed that AtETR1 could interact with AtCTR1 strongly in the ProQuest system (Figure 3.32). This indicates that the GAL4-based ProQuest yeast two-hybrid system is capable of detecting the interaction between AtETR1 and AtCTR1, although it is unable to demonstrate the interaction between LeETR1 and LeCTR2. This raises a critical question as to the significance of the interaction detected in the LexA-based yeast two-hybrid system.

In order to gain more insight into the protein-protein interaction between the tomato ethylene receptors and CTRs, the six tomato ethylene receptors (LeETR1 to 6) and the four tomato CTRs (LeCTR1 to 4) were cloned and tested in the ProQuest system. The subsequent yeast two-hybrid assay showed that only LeCTR3 could interact with the sub-family I ethylene receptors (LeETR1, LeETR2 and Nr) (Figure 3.33). It has been previously shown that the CN box mutation could not disrupt the protein-protein interaction between LeCTR2 and the ethylene receptors in the LexA-based yeast two-hybrid system (Figure 3.31). The same Gly to Glu mutation was then introduced to the CN motif of LeCTR3 by PCR mutagenesis and this construct was subsequently tested in the ProQuest system. The yeast two-hybrid assay (ProQuest) showed that the mutated CTR3 protein lost its interaction with the ethylene receptors (Figure 3.34). However, it is not clear why LeCTR1, 2 and 4 showed no interaction with the receptors in the yeast two-hybrid assay. This is particularly interesting, since it has been reported that LeCTR1, 3 and 4 could complement the *Arabidopsis CTR1* loss-of-function mutant

(Adams-Philips *et al.*, 2004). Furthermore, the interaction between the tomato CTRs and the ethylene receptors has been previously demonstrated using the LexA system (Lin and Grierson, unpublished data). Collectively, these findings suggest that the ProQuest yeast two-hybrid system is indeed more stringent than the LexA-based one, but it might not be able to detect the weak interactions. Therefore, to help resolve this issue, the *in vivo* protein-protein interaction was investigated.

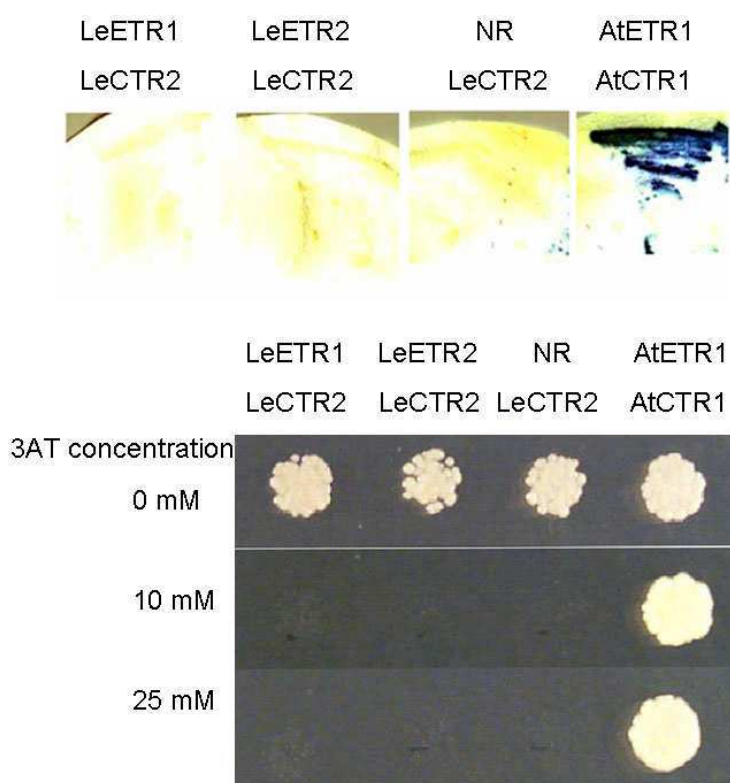

Figure 3.32: LeCTR2 does not interact with the ethylene receptors

The yeast two-hybrid assay was performed using the GAL4-based ProQuest yeast two-hybrid system (Invitrogen) as previously described (Section 2.13.3). Yeast transformed with AtETR1¹¹²⁻⁷³⁷ and AtCTR1¹⁻⁵²⁶ activated both reporter gene: *LacZ* (indicated by the blue colour in the filter lift assay) and *His* (indicated by the growth of yeast in histidine minus medium supplemented with 3-aminotriazole (3AT)). Yeast transformed with LeCTR2¹⁻⁶⁷⁸ and the ethylene receptors (LeETR1¹³²⁻⁷⁵⁴, LeETR2¹¹⁵⁻⁷³² and Nr¹¹⁷⁻⁶³⁵) showed no activation of the reporter gene.

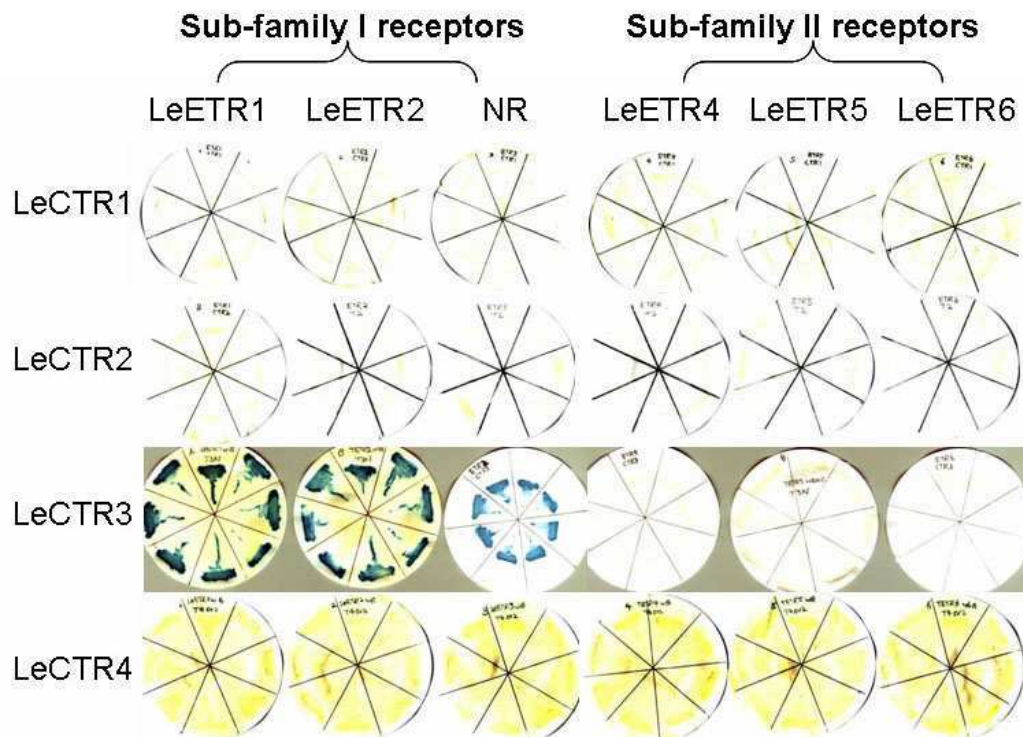

Figure 3.33: LeCTR3 interacts with sub-family I ethylene receptors

The yeast two-hybrid assay was performed using the GAL4-based ProQuest yeast two-hybrid system (Invitrogen). Yeast transformed with LeCTR3¹⁻⁵⁶⁵ (in prey plasmid pDEST22) and the sub-family I ethylene receptors LeETR1¹³²⁻⁷⁵⁴, LeETR2¹¹⁵⁻⁷³² and Nr¹¹⁷⁻⁶³⁵ (in bait plasmid pDEST32) showed *LacZ* reporter gene activity as indicated by the blue colour in the filter lift assay. This suggested that the LeCTR3 could associate specifically with the sub-family I ethylene receptors. The sub-family II receptors (LeETR4, LeETR5 and LeETR6), however, could not interact with any CTR in this Gal4-based yeast two-hybrid system.

























	<i>lacZ</i> reporter		<i>His</i> reporter	
	LeCTR3	G347 to E mutated	LeCTR3	G347 to E mutated
LeETR1				
LeETR2				
Nr (LeETR3)				
LeETR4				
LeETR5				
LeETR6				

Figure 3.34: Gly³⁴⁷ to Glu mutated LeCTR3 in the yeast two-hybrid assay

Yeast transformed with the mutated LeCTR3 protein and the tomato ethylene receptors (ETR1 to 6) could not activate the reporter genes of the yeast two hybrid system. It indicated that mutation of the conserved CN motif in LeCTR3 disrupted its interaction with the ethylene receptors. The *LacZ* reporter produces a blue colour on filter lift assays. Failure to activate the *His* gene stopped the yeast growing on medium deprived of histidine.

3.9 Transient Expression of Fluorescent Proteins

3.9.1 Generating the CFP/GFP/YFP series of plasmids

In order to study the *in vivo* protein-protein interactions between the tomato ethylene receptors and CTRs, a transient expression system was developed. Particle bombardment was chosen as the method to deliver the test transgene constructs. Onion epidermal cells were used as the recipient tissue due to their lack of intrinsic chlorophyll auto-fluorescence. The plasmid pDH51 (Figure 3.35; Pietrzak *et al.*, 1986), which contains a CaMV 35S promoter, a multiple cloning site (MCS) and a 35S terminator, was chosen as the backbone of the cloning vectors.

The CFP variant Cerulean was generated by PCR incorporating three mutations (S72A, Y145A and H148D) to the coding sequence of ECFP (BD Clontech). EGFP was amplified from the plasmid pK7FWG2 (Karimi *et al.*, 2002). The YFP variant Venus (F46L, F64L, M153T, V163A and S175G) was PCR amplified from plasmid pCS2-Venus (a kind gift from Dr. Atshushi Miyawaki, RIKEN Institute, Japan). The cDNAs of the three fluorescent proteins were then cloned into the pDH51 plasmid between the *Bam*HI and *Sal*I sites and tested in transient expression (Figure 3.36; for map and sequence see accompanying CD). The resulting plasmids containing an *Xho*I site in front of the first ATG of the fluorescent protein coding sequence were referred to as pDH51-x-FP (Figure 3.36). The *Xho*I and *Sma*II sites were used to clone the Gateway (Invitrogen) fragment for generating pDestination vectors.

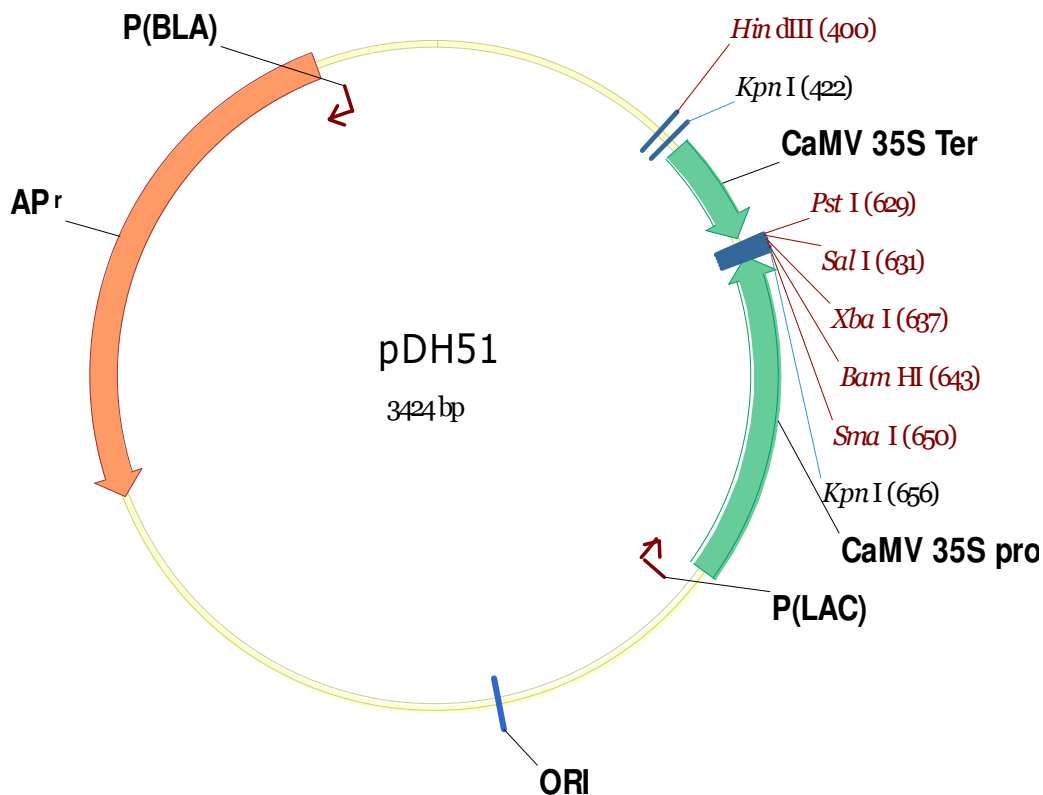
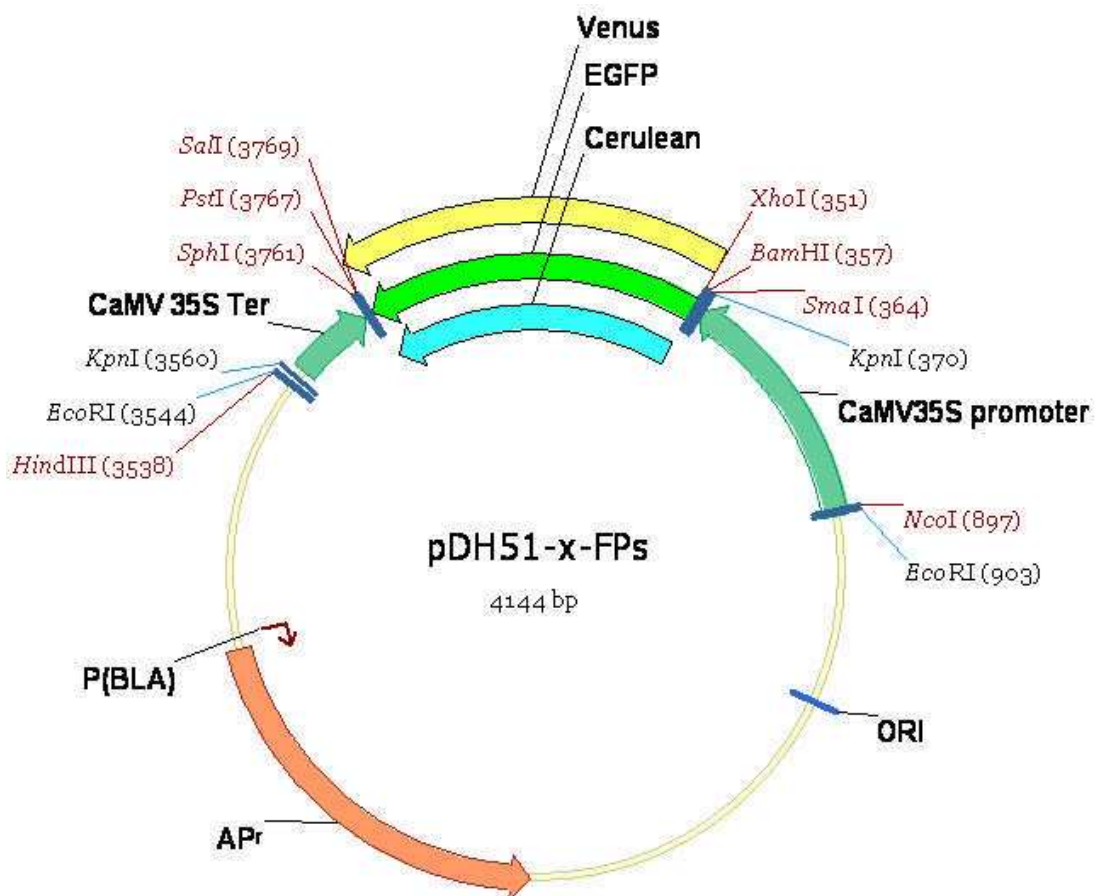

Figure 3.35: pDH51 plasmid

The schematic diagram of the plasmid pDH51 was generated by software VectorNTI (Invitrogen). The multiple cloning site (MCS) is between the CaMV35S promoter and the CaMV35S terminator. Unique restriction enzymes are shown in colour red. AP^r: ampicillin resistance gene; CaMV35S ter: cauliflower mosaic virus terminator; CaMV35S pro: cauliflower mosaic virus promoter; P(LAC): Lac promoter; ORI: origin of replication.



+1 KpnI Small BamHI XhoI SalI PstI SphI
 ACACGGTACCCGGGGATCCCTCGAG ATG-(GFP)-TAA-GTCGACCTGCAGGCATGC

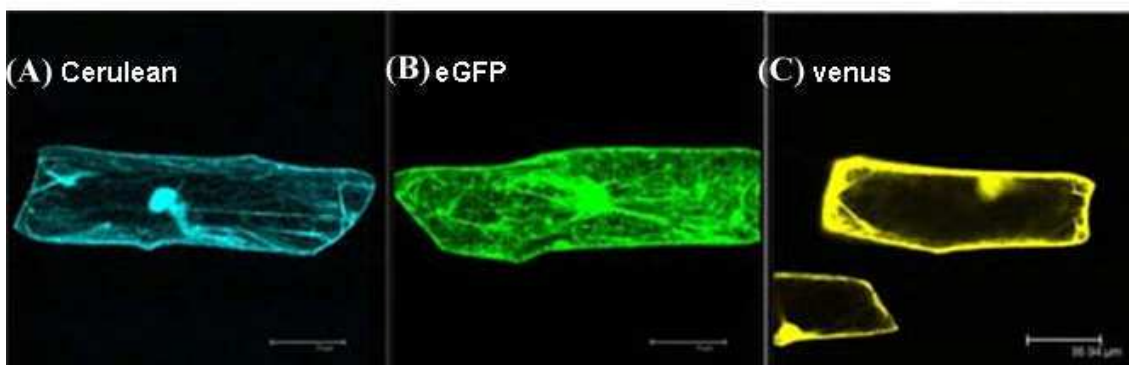

Figure 3.36: pDH51-x-FP plasmid

The schematic diagram of the plasmid pDH51-x-FP (CFP, GFP and YFP) was generated by software VectorNTI (Invitrogen). The multiple cloning site (MCS) is shown below the plasmid map. These plasmids were coated onto gold particles and transiently expressed in onion epidermal cells as previously described (Section 2.15.2). The images were acquired by using the confocal scanning microscope 10 h after the transformation.

3.9.2 Generating gateway cloning vectors: pDH51-GW-FP

In order to convert the fluorescent protein plasmids to Gateway cloning compatible pDestination vectors (Invitrogen), the Gateway DNA fragment was PCR amplified using primers anchored to its *attR* sites (5'-caccggatccacaagtttgtaaaaaagctgaa-3' and 5'-tttctcgagcaccactttgtacaagaaagc-3'). The PCR product was then digested with *XhoI*, and ligated to the *SmaI* and *XhoI* linearized pDH51-x-FP plasmids. The generated plasmids were referred to as pDH51-GW-CFP (Accession: AM773751), pDH51-GW-EGFP (Accession: AM773752) and pDH51-GW-YFP (Accession: AM773753), respectively (Figure 3.37; see accompanying CD for maps and sequence information).

To test the pDH51-GW-FP vectors, the full-length cDNA of IntCR242 and the ethylene receptor NR were cloned into these vectors and transiently expressed in the onion epidermal cells. IntCR242-GFP was targeted to plastid and stromule (Figure 3.37 B), which is in agreement with the results of the previous protein localization experiments using stable transgenic tobacco plants (see section 3.6.2 for details). The tomato ethylene receptor NR fused to YFP highlighted the cortical network of endoplasmic reticulum (ER) when transiently expressed in onion cells (Figure 3.37 C). CFP fused to the N-terminal ER targeting sequence of the pumpkin 2S albumin and the C-terminal ER retention sequence HDEL was used as the ER controls in the transient expression experiments.

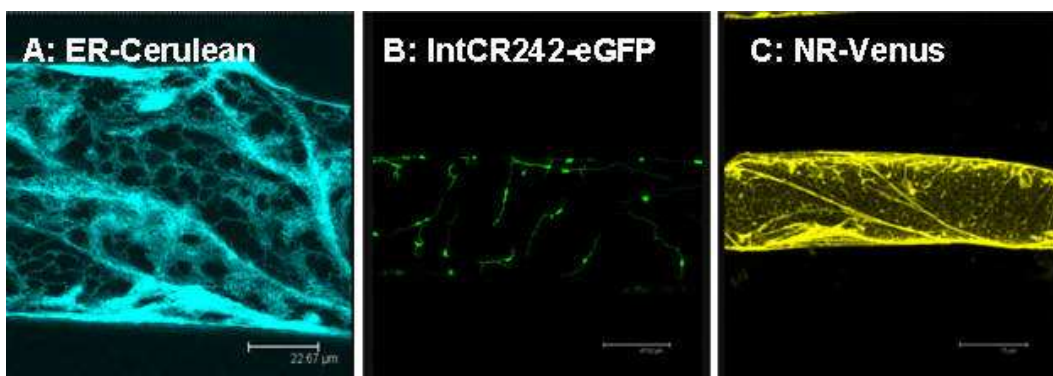
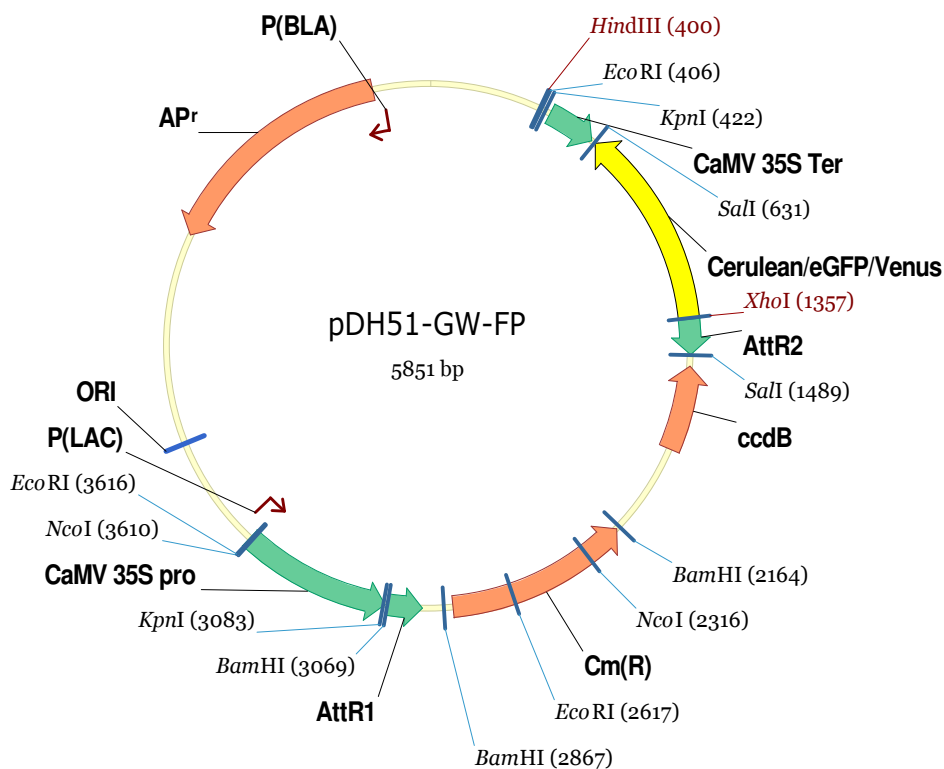

Figure 3.37: pDH51-GW-FP plasmids

A schematic diagram of the plasmid pDH51-GW-FP (CFP, GFP and YFP) is generated by software Vector NTI (Invitrogen). The ER CFP marker, IntCR242-EGFP and ethylene receptor NR-YFP were transiently expressed in onion epidermal cells and imaged 10-14 h after transformation.

- (A): ER targeting CFP (Cerulean)
- (B) IntCR242-EGFP in plastid and stromule.
- (C) NR-YFP (Venus)

3.9.3 Construction of the BiFC vectors and modified pGreenII binary vectors

In order to use the Biomolecular Fluorescence Complementation (BiFC) experiment to study *in vivo* protein-protein interactions, the coding sequence of the N- and C-terminus of YFP (Venus¹⁻¹⁵⁴ and Venus¹⁵⁵⁻²³⁸) were PCR amplified and cloned into the plasmid pDH51. The resulting plasmids were referred to as pDH51-nVenus and pDH51-cVenus, respectively (see accompanied CD for details). The DNA fragment containing the Gateway cassette was then cloned in to the nVenus and cVenus plasmids to generate Gateway compatible pDestination vectors; they are referred to as pDH51-GW-YFPn and pDH51-GW-YFPc (Figure 3.38; see accompanying CD for sequence information). The pDH51-based vectors do not contain either T-DNA borders or the origin of replication in *Agrobacterium* and therefore could only be used for biolistic or protoplast transformation. Collaboration was formed with Dr. Rupert Fray (Plant Sciences Division, University of Nottingham) to generate binary vectors for *Agrobacterium*-mediated plant transformation. The pDH51-based Gateway plasmids were digested with *EcoRI* and *HindIII* to release the DNA fragments containing the 35S promoter, gateway cloning cassette, fluorescent protein and terminator. These were then cloned into binary plasmids (pGreenII0029, pGreenII00179 and pGreenII00229) with different *in planta* selection marker genes. Another set of binary vectors lacking the constitutive CaMV35S promoter has also been generated using the *KpnI* released fragments from the pDH51-based plasmids (see accompanying CD for details). A complete list of the plasmids with the accession numbers were shown in Appendix (Table 1 to 3).

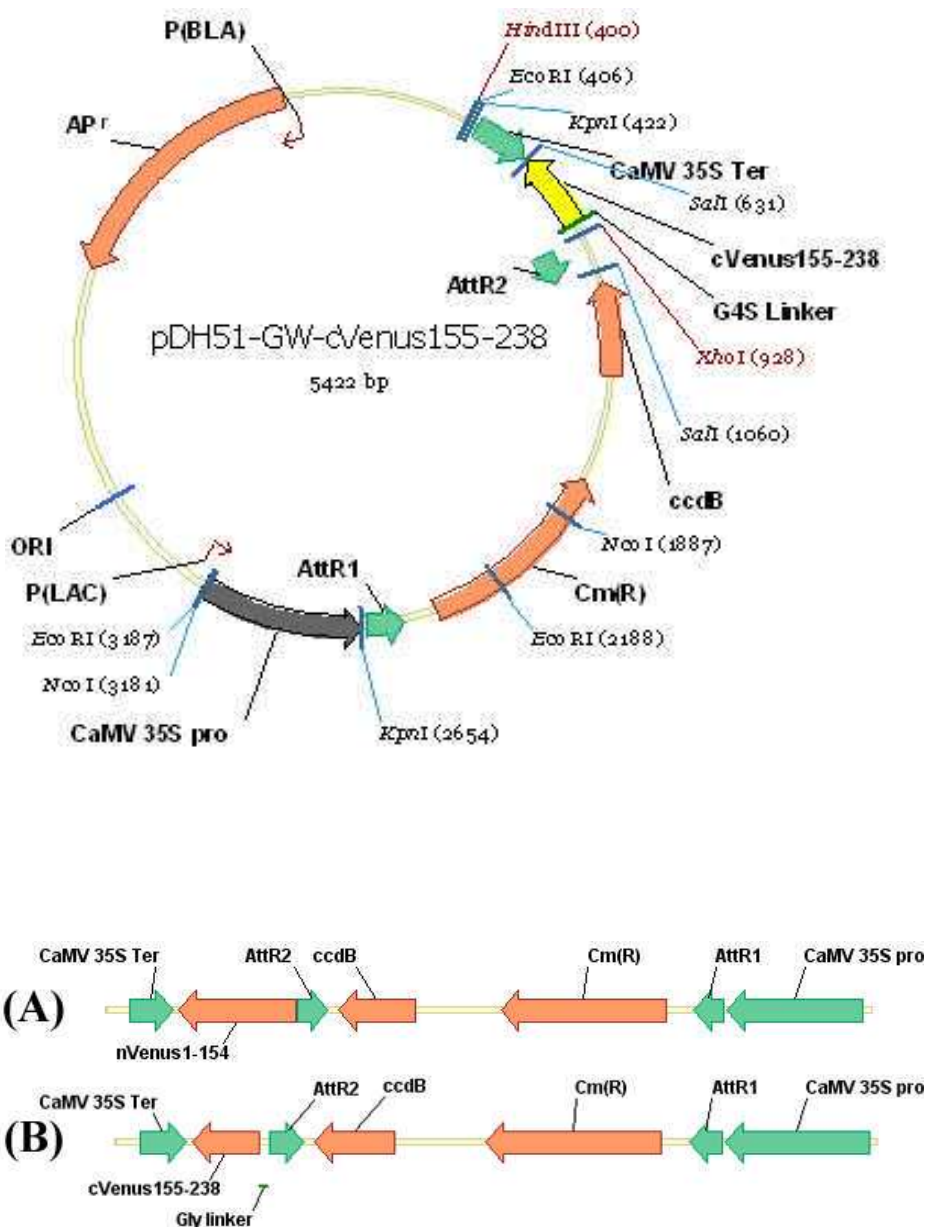

Figure 3.38: Schematic diagram of BiFC vectors

The schematic diagram of one BiFC vector (pDH51-GW-cVenus) is shown. The pDH51-based vector contains a 35S promoter, gateway cloning sites (between *attR1* and *attR2*), a linker peptide, the N- or C-terminal fragment of Venus (YFP) and a 35S terminator.

(A) Fragment of pDH51-GW-nVenus

(B) Fragment of pDH51-GW-cVenus

3.10 Localization of Ethylene Receptors and CTRs

3.10.1 The tomato ethylene receptors are targeted to the ER

The full-length coding sequences of the tomato ethylene receptors NR and ETR4 were cloned into the vector pDH51-GW-GFP. Both receptors (fused to fluorescent protein) were targeted to the ER when transiently expressed in onion epidermal cells (Figure 3.39 and 4.11). Cortical ER localization pattern was also observed when an ER membrane protein (AtSec12p) fused to CFP was transiently expressed as an ER marker (Figure 3.39). The fluorescent protein Venus fused to the N-terminal pumpkin albumin ER targeting sequence and the C-terminal ER retention sequence HDEL was also transiently expressed in the onion cells as the ER marker (referred to as ER-YFP-HDEL) and it highlighted the same cortical ER network (Figure 3.40).

However, the NR-GFP fluorescence was not evenly distributed in the ER network (Figure 3.39). It was observed that NR-GFP accumulated in an unknown aggregation body 15-18 h after the biolistic transformation, whilst expression of the two aforementioned ER makers did not cause such severe aggregation (Figure 3.41). This is consistent with a previous report that expression of the *Arabidopsis* ethylene receptor ETR1 in *Arabidopsis* protoplasts using the strong CaMV 35S promoter caused protein aggregation (Chen *et al.*, 2002). It was therefore hypothesized that the aggregation was caused by over-expression of the ethylene receptor in the ER. To investigate whether the receptor aggregation was an artefact resulting from NR-GFP over-expression, the ER

marker (YFP-HDEL targeted to ER lumen) was co-expressed with NR-CFP in the onion cells for 24 h to allow the receptor to aggregate. The NR-CFP aggregation bodies were found near the nucleus peripheral space and the NR-CFP fluorescence was absent in the cortical ER network (Figure 3.41). On the other hand, the ER network was still highlighted by the YFP fluorescence generated by the YFP-HDEL construct. This suggests that the aggregation of NR-CFP did not result in disruption of the ER but rather, an artefact as a result of over-expression as reported by Chen *et al.* (2002).

The N-terminus of the tomato ethylene receptor ETR1 (aa 1-137) was cloned into the pDH51-GW-CFP vector to fuse the transmembrane domains of the receptor to CFP. This construct was then transiently expressed in the onion epidermal cells and the LeETR1¹⁻¹³⁷-GFP protein was found in the cortical ER network (Figure 3.42). In *Arabidopsis*, it has been hypothesized that a membrane protein RTE1 regulates ethylene sensitivity by controlling the signal output of the ethylene receptor AtETR1 (Resnick *et al.*, 2006). In tomato, it has been shown that GREEN-RIPE (GR) shares sequence homology to the *Arabidopsis* RTE1 and its ectopic expression results in reduced ethylene responsiveness in fruit tissue (Barry and Giovannoni, 2006). To gain more insight into GR's localization and relation with the tomato ethylene receptors, it was cloned into the pDH51-GW-Venus vector and transiently expressed in onion, in which the GR-YFP signal highlighted an unknown punctated structure. Co-expressing GR-YFP with an *Arabidopsis* Golgi nucleotide/sugar transporter GONST1 fused to CFP indicated the punctated structure was Golgi bodies (Figure 3. 42).

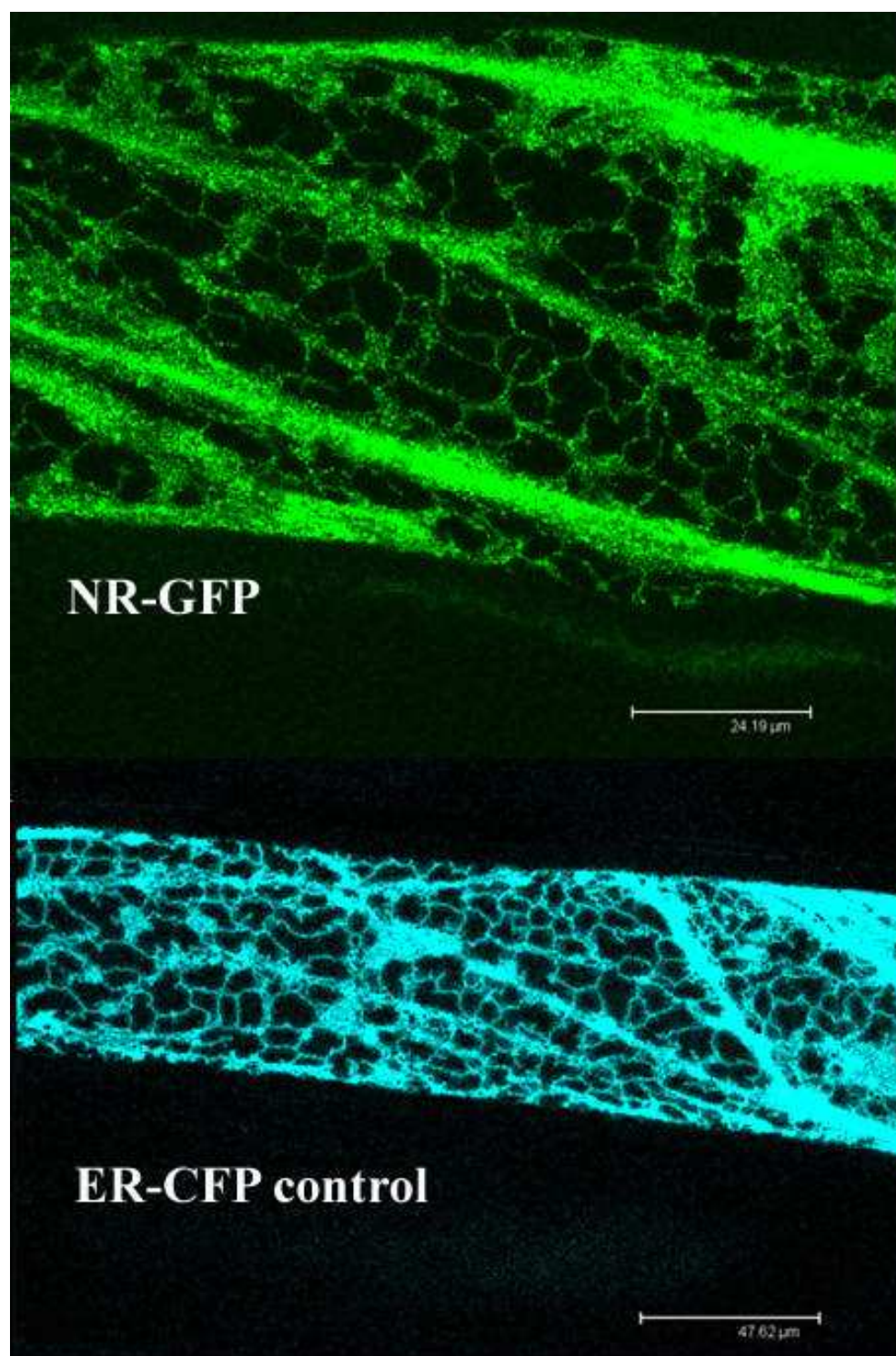

Figure 3.39: Never-Ripe was localized to the ER membrane in the onion cell

The transformed onion cells were incubated in a tissue culture room (22-24°C) for 14 hours before the fluorescence images were taken using the confocal scanning microscope. The NR-GFP fluorescence was predominantly localized in the cortical network of the endoplasmic reticulum. It should be noted that the NR-GFP fluorescence is not evenly distributed in the ER. The ER-CFP marker (AtSec12p-CFP) was also transiently expressed in an onion cell and imaged.

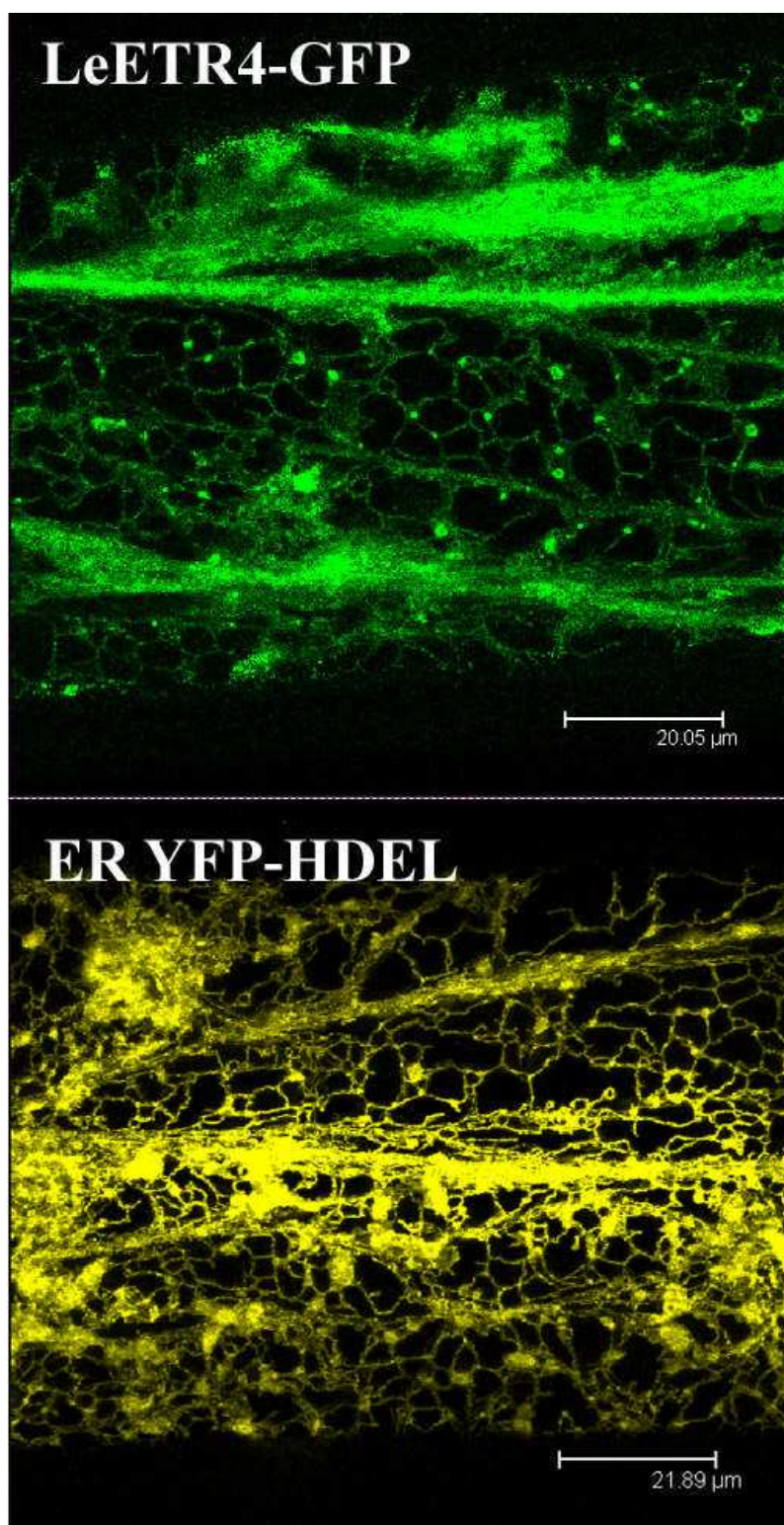

Figure 3.40: ETR4 was localized to the ER of the onion epidermal cell

The transformed onion cells were incubated in a tissue culture room (22-24°C) for 14 hours before the fluorescence images were taken using the confocal scanning microscope. The ETR4-GFP fluorescence was predominantly localized in the cortical network of the endoplasmic reticulum. YFP (Venus) fused to the ER retention sequence (YFP-HDEL) was transiently expressed in onion as an ER marker.

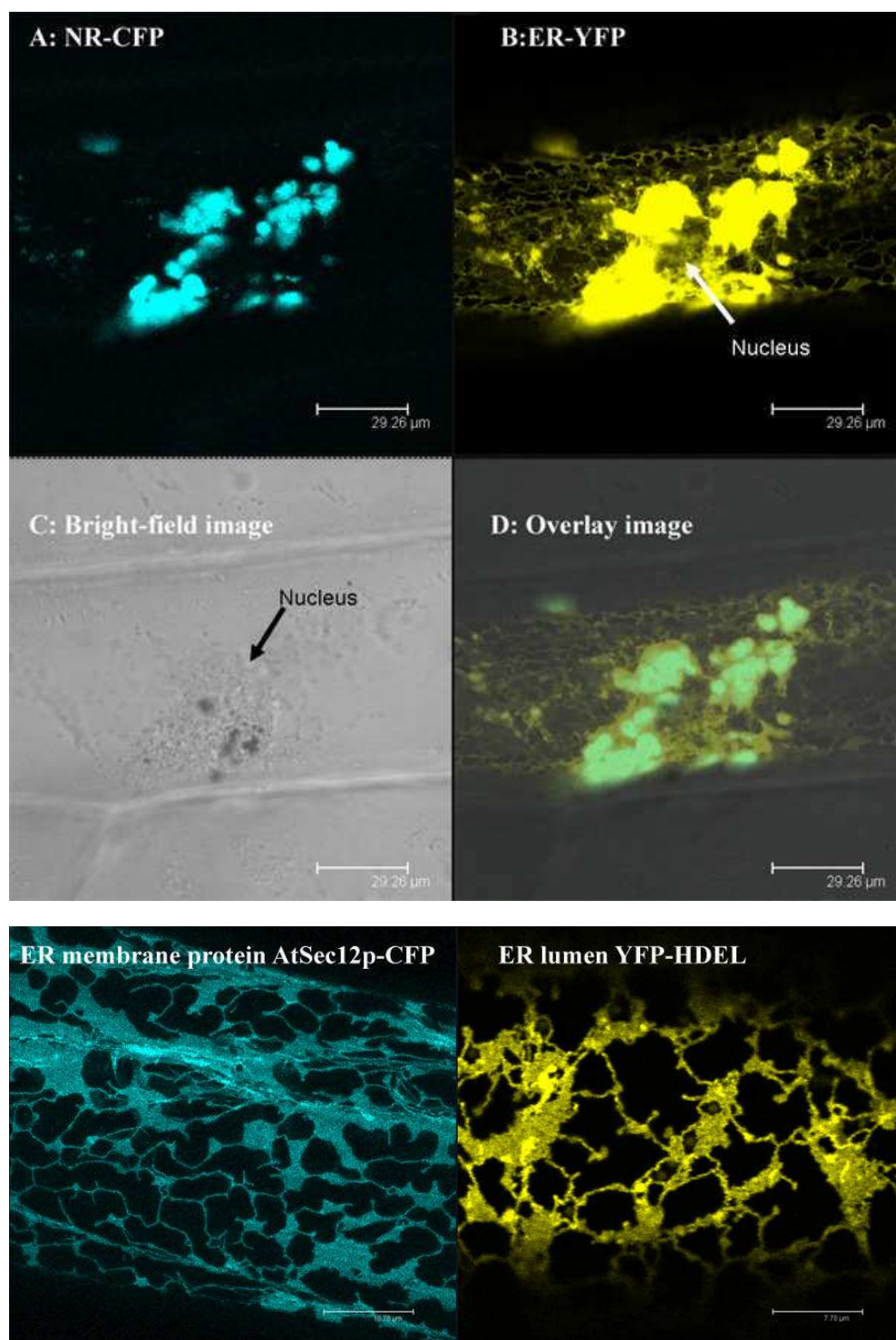

Figure 3.41: NR protein aggregation after prolonged expression

An onion cell was co-transformed with NR-CFP and the ER lumen YFP. The images were acquired 24 h after transformation. The images of AtSec12-CFP and YFP-HDEL are shown as ER controls. A) The NR-CFP aggregated around the nucleus. (B) The ER lumen YFP highlighted the cortical ER network. (C) The bright-field image. (D) The superimposed image.

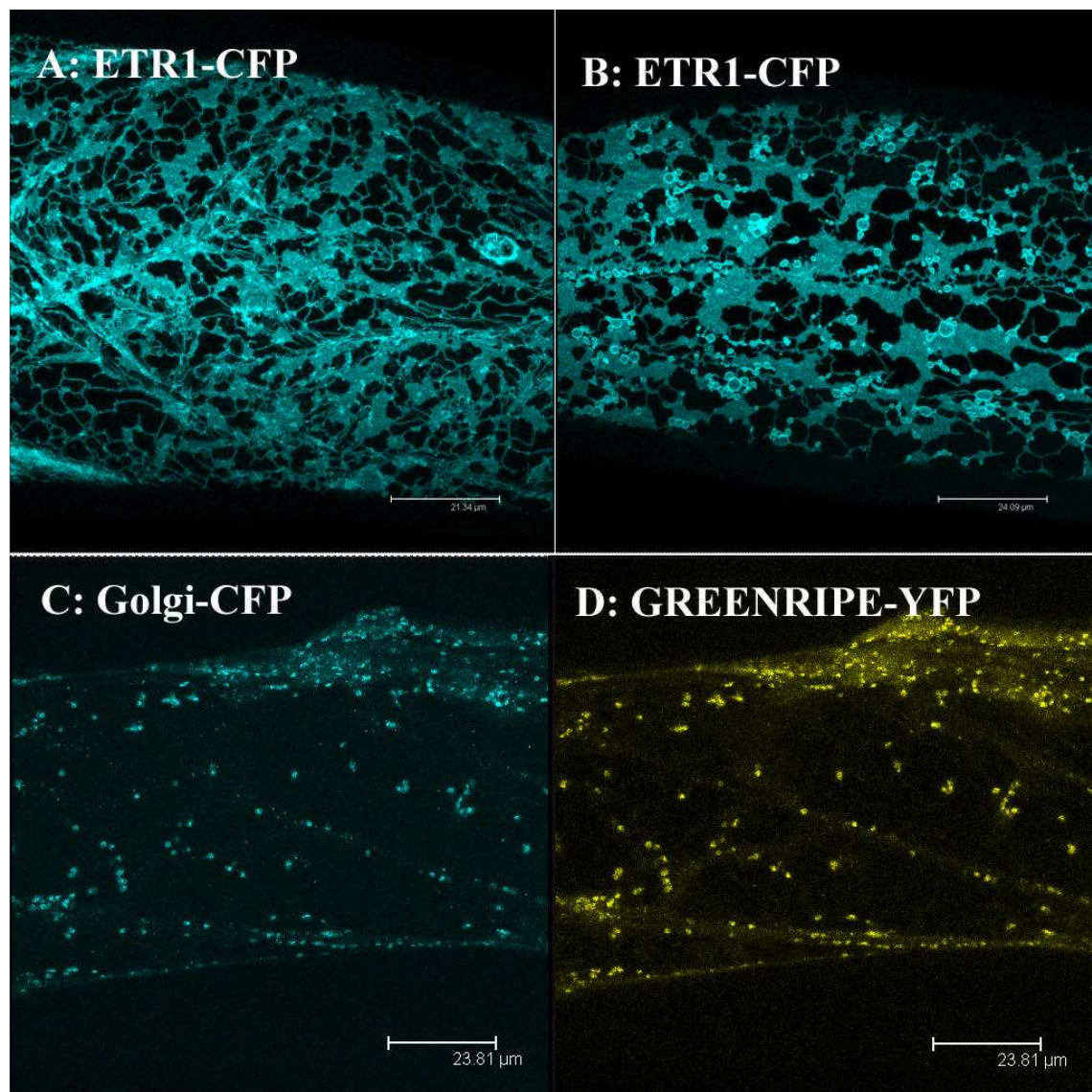

Figure 3.42: LeETR1 was targeted to the ER in onion cells

The N-terminus of ethylene receptor ETR1 (aa 1-137) fused to CFP variant Cerulean was located to the ER when transiently expressed in onion epidermal cells. The newly discovered ethylene signalling component GREEN-RIPE fused with YFP (Venus) could co-localized with the Golgi marker GONST1-CFP, which is an *Arabidopsis* Golgi nucleotide/sugar transporter.

(A and B) Confocal images show two onion cells expressing the N-terminus of LeETR1 fused to CFP.

(C and D) A single onion cell expressing *Arabidopsis* Golgi protein GONST1-CFP as Golgi localization marker and an ethylene signalling component GREEN-RIPE fused to YFP.

3.10.2 NR dependent ER localization of CTR1, 3 and 4

It has been reported that the ER localization of the *Arabidopsis* CTR1 is dependent on the presence of the ER membrane-bounded ethylene receptors (Gao *et al.*, 2003). The authors also suggested that AtCTR1 would dissociate from the ER if the interaction between AtCTR1 and the ethylene receptors were disrupted by the CN motif mutation. In order to gain further insight into the ethylene receptor-CTR interaction, the sub-cellular localization of the tomato CTRs was investigated. The cDNAs encoding the N-termini of the four tomato CTRs (LeCTR1, LeCTR2, LeCTR3 and LeCTR4) were cloned into the transient expression plasmid pDH51-GW-YFP. The LeCTR proteins fused to YFP were localized to the cytoplasm and nucleus when transiently expressed in the onion epidermal cells (Figure 3.43). When the LeCTR-YFP proteins were co-expressed with the full-length ethylene receptor NR (fused to CFP), three of the LeCTR-YFP proteins (LeCTR1, LeCTR3 and LeCTR4) were found to be associated with the ER and co-localized with the NR-CFP (Figure 3.44). In the case of LeCTR2, which showed no interaction with NR in the yeast two-hybrid assay (Section 3.8), no LeCTR2-YFP fluorescence signal could be found in the cortical ER network when co-expressed with NR. To confirm that CTRs alone could not be targeted to the ER when transiently expressed in onion, these CTR-YFP constructs (CTR1, CTR2 and CTR3 fused to Venus) were co-expressed with an ER lumen targeted CFP construct (Cerulean-HDEL). None of the CTR-YFP proteins could co-localize with the ER-CFP (Figure 3.45), which indicates that the ER localization of CTR in Figure 3.44 is indeed dependent on the presence of the ethylene receptor NR.

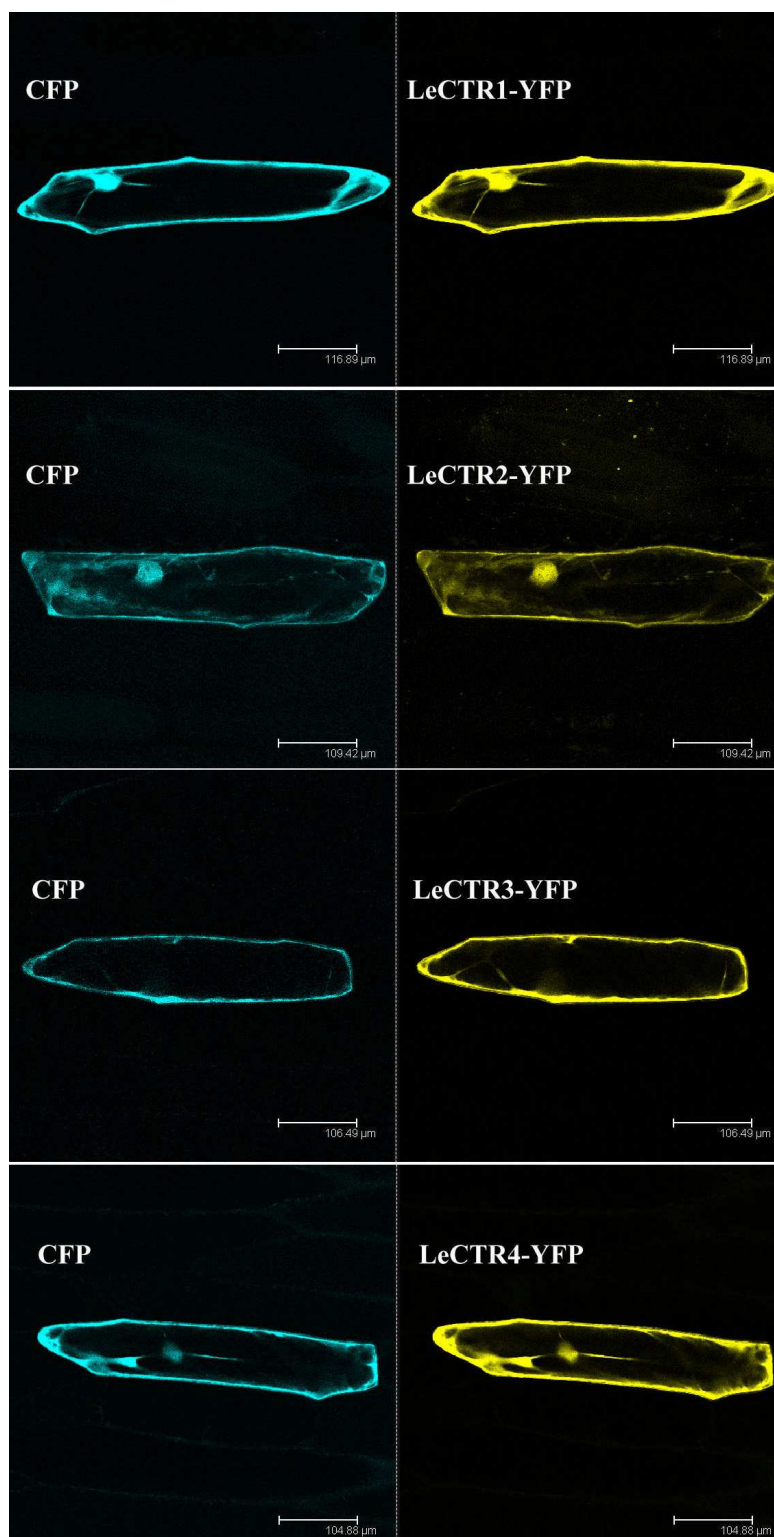

Figure 3.43: LeCTR alone was targeted to cytoplasm and nucleus

Images were acquired from onion cells co-expressing CFP and LeCTR-YFP. CFP alone is known to be located in the cytoplasm and nucleus. All LeCTRs fused to YFP have the same localization pattern as the CFP control. This indicates they were targeted to the cytoplasm and nucleus when transiently expressed in the onion epidermal cells without the tomato ethylene receptors.

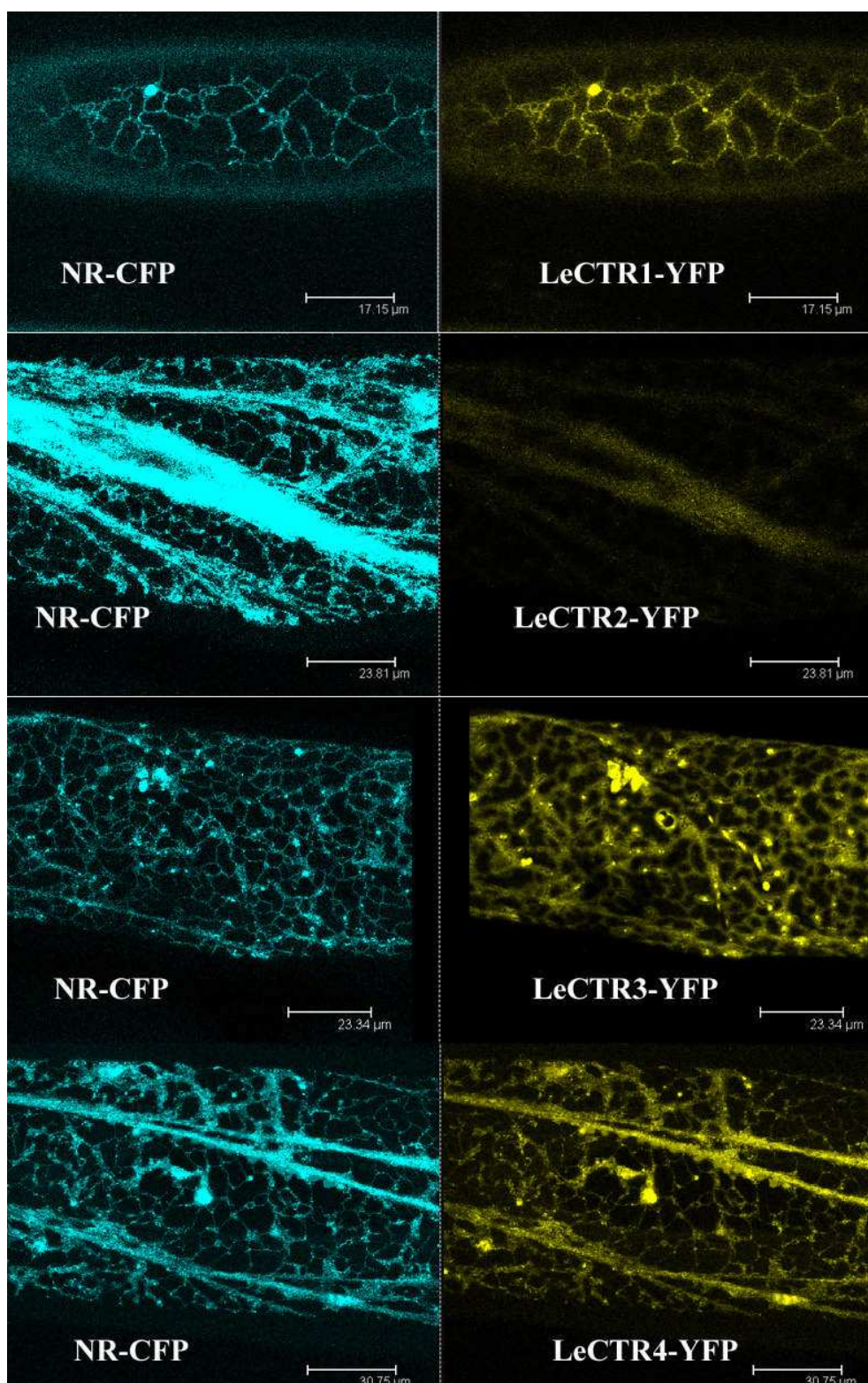

Figure 3.44: LeCTR1, 3 and 4 co-localized with NR in the ER membrane

Confocal images were acquired from onion cells co-expressing NR-CFP and four LeCTRs fused to YFP. Only LeCTR2 was absent from the ER when co-expressed with the receptor NR-CFP.

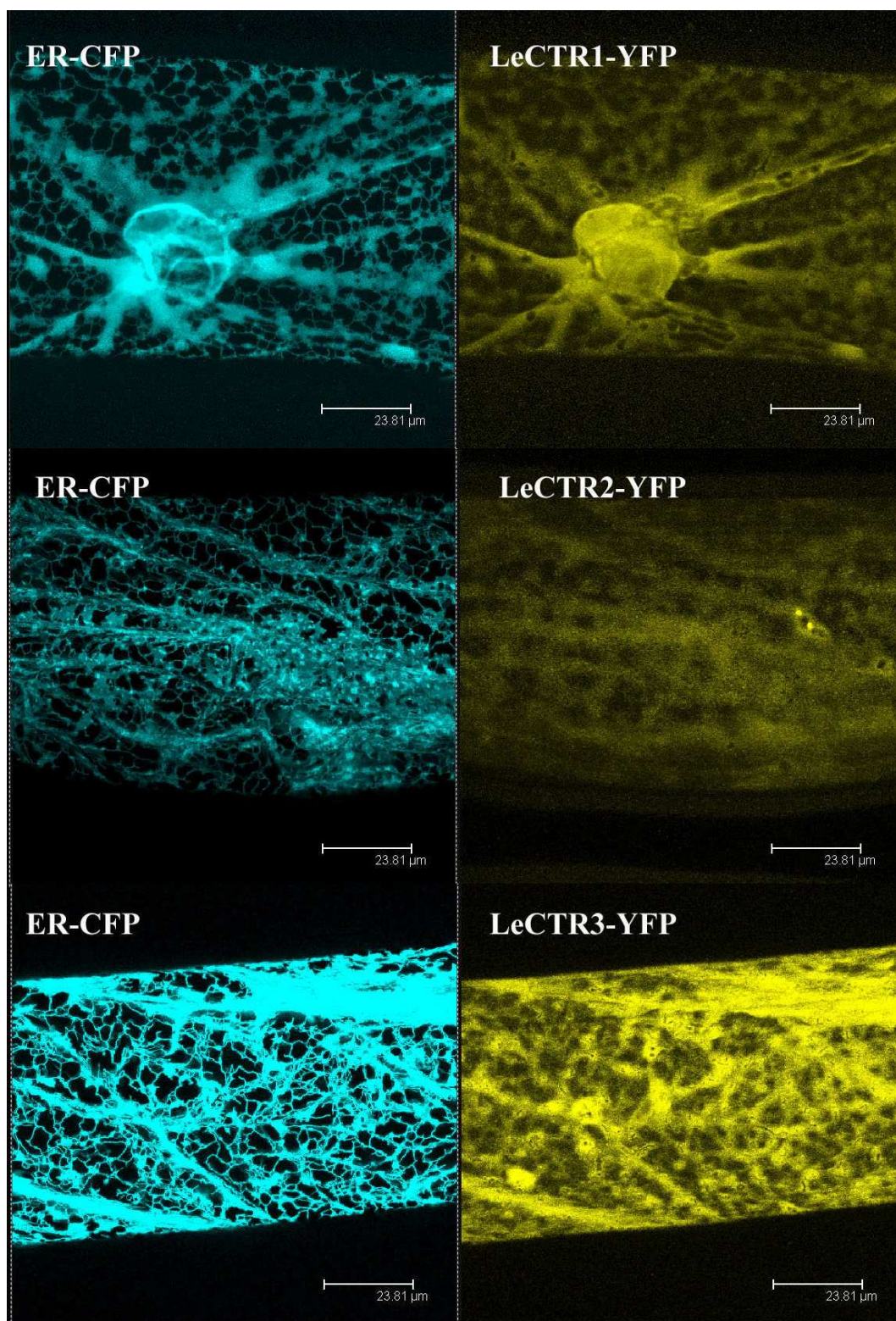

Figure 3.45: LeCTRs did not co-localize with ER-CFP

LeCTR1, 2 and 3 fused to YFP were co-expressed with the ER-CFP marker in onion epidermal cells. The CTR-YFP fluorescence signal did not co-localize with the ER-CFP, which confirms that the CTRs alone could not be targeted to the ER.

3.10.3 Biomolecular fluorescence complementation (BiFC)

The method of choice to examine the *in planta* protein-protein association is Foster resonance energy transfer (FRET). However, efforts to detect the FRET between the ethylene receptor ETR1 and the CTRs were unsuccessful possibly due to the tendency of the ethylene receptor ETR1 to form aggregation bodies (data not shown). Therefore, biomolecular fluorescence complementation (BiFC) assay was used to investigate the receptor-CTR interaction.

The overall strategy of BiFC was outlined in Figure 3.46. In the BiFC assay, the tomato ethylene receptors were expressed in onion cells fused to the N-terminus of YFP (YFPN, aa 1-154) and the putative downstream kinases (CTRs) were expressed with the C-terminus of YFP fusion (YFPC, aa 155-238). Neither YFPN nor YFPC is fluorescent by itself, unless the ethylene receptor associates with CTR, in which case the N- and C-terminus of the YFP would be brought together and a functional YFP would be regenerated. Therefore, the fluorescent emission of the newly formed YFP would be an indication of the protein-protein association between the ethylene receptor and CTR.

As BiFC is a relatively novel technique and has not yet been used to study receptor-CTR interaction, a control experiment was carried out using the ethylene receptor NR. Because in this study, it has been shown that all the tomato CTRs except for CTR2 could co-localize with the ethylene receptor NR (Figure 3.44) and this is also

in agreement with the previous yeast two-hybrid assay that LeCTR2 could not interact with NR (see section 3.8 for details). Therefore, it was reasoned that if the NR-LeCTR1 BiFC pair showed a positive result in the pilot experiment, whilst the NR-LeCTR2 pair could not, this BiFC method would be suitable to investigate the ethylene receptor-CTR interaction. The control BiFC experiment showed that NR has strong BiFC with CTR1 but not with CTR2 (Figure 3.47). Therefore, the interaction between the ethylene receptor LeETR1 and the four CTRs were subsequently examined. The results in Figure 3.48 show that only CTR1, 3 and 4 could have fluorescence complementation with LeETR1 in the BiFC assay. This suggests that LeCTR2 might not be able to interact with LeETR1, which is also in agreement with the ProQuest yeast two-hybrid assay results (see section 3.8).

However, it is not clear whether or not the recombinant LeCTR2 protein fused to the C-terminus of YFP (LeCTR2-YFPC) has been properly expressed; as the LeCTR2-YFPC protein by itself is not fluorescent and could not be detected by using the fluorescent microscope. For example, negative BiFC result would be obtained if the LeCTR2 has not been cloned in frame with the downstream YFPC or the expression of the recombinant protein was suppressed. To help resolve the issue, western blot using anti-GFP antibody could be performed to confirm the presence of the LeCTR2-YFPC protein. However, it is not practical to extract sufficient protein from onion epidermal cells for western blot analysis due to the low efficiency of the biolistic transformation.

It has been reported that the N-terminus of YFP (YFPN) alone can show BiFC with any protein fused to the C-terminus of the YFP (YFPC) through self-assembling (Hu *et al.*, 2000; Hu and Kerppola, 2003; Shyu *et al.*, 2006). The YFPN protein would therefore act as a positive control to demonstrate that the protein fused to YFPC could be correctly expressed. In order to rule out the possibility that lack of a positive BiFC signal in the LeETR1-LeCTR2 experiment is due to the failure of LeCTR2-YFPC protein expression, a control experiment was performed to co-express YFPN with LeCTR2-YFPC. This combination generated a strong BiFC signal and confirmed that the LeCTR2-YFPC protein could be expressed (Figure 3.49). Therefore, the negative BiFC result of LeETR1-LeCTR2 in Figure 3.48 is unlikely to be resulted in experimental error such as lack of LeCTR2-YFPN protein expression.

Collectively, the BiFC analysis suggests that only LeCTR1, LeCTR3 and LeCTR4 could interact with the ethylene receptors LeETR1 when transiently expressed in the onion epidermal cells, while LeCTR2 might not take part in the protein-protein interaction with the ethylene receptor.

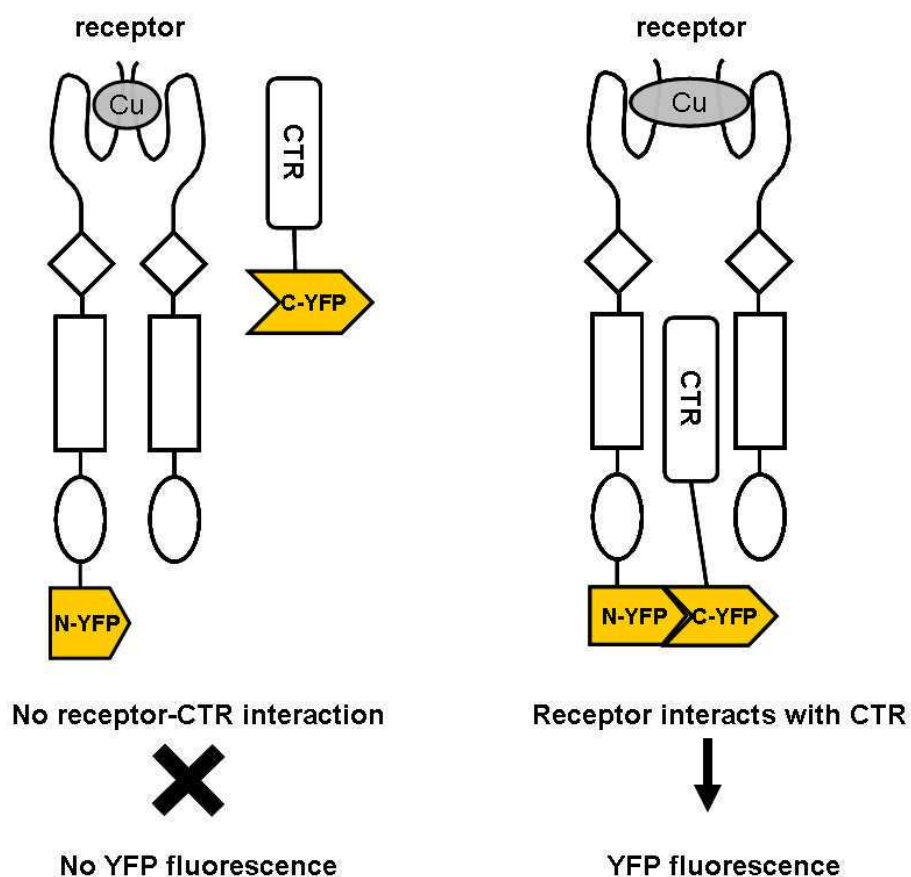

Figure 3.46: Biomolecular fluorescence complementation (BiFC)

The ethylene receptors were fused to the N-terminus of YFP (N-YFP) and the CTRs were fused to the C-terminus of YFP (C-YFP). Neither the N- or C-terminal domain of the YFP would be expected to show any fluorescence by itself (left), unless CTR interacts with the receptor, in which case the two separated fragments of YFP would be brought together and the YFP emission would be observed (right).

In a BiFC assay, onion cells are co-transformed with three constructs that include:

- 1) The ethylene receptor fused to YFPN
- 2) CTR fused to the YFPC
- 3) A construct expressing the red fluorescent protein mRFP1, which act as the indicator for successful transformation.

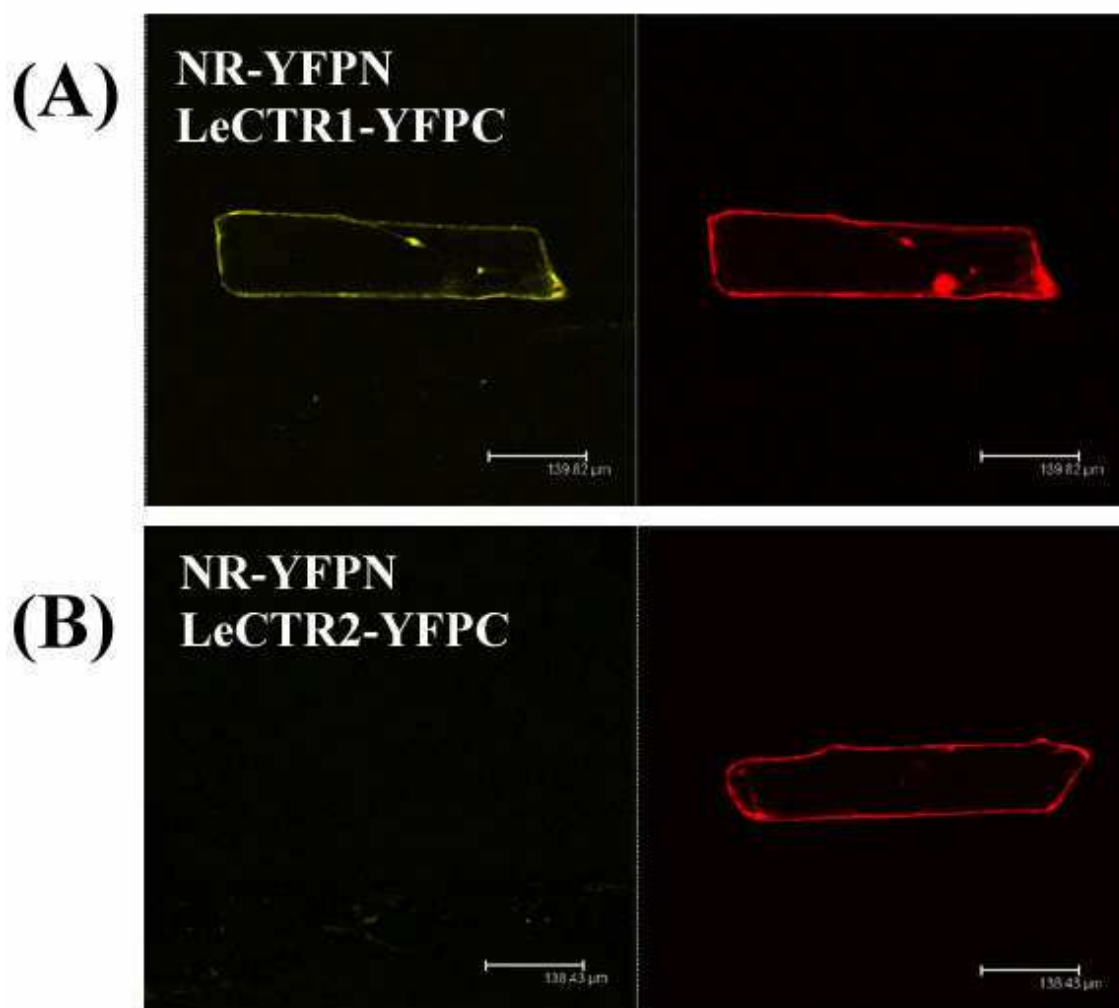

Figure 3.47: BiFC assay of the receptor NR with CTR1 and CTR2

The onion cell expressing NR-YFPN and CTR1-YFPC showed yellow fluorescence in the BiFC channel. This suggests that the LeCTR1 can associate with NR. The left images (yellow) were from the BiFC channel, in which the presence of YFP fluorescence indicates a positive protein-protein interaction result. The red images (right) were from the red fluorescent protein co-transformed with the BiFC constructs, which serves as the indicator of successful transformation. YFPN: N-terminus of YFP; YFPC: C-termini of YFP.

(A) An onion cell co-transformed with NR-YFPN, LeCTR1-YFPC and mRFP1.

(B) An onion cell co-transformed with NR-YFPN, LeCTR2-YFPC and mRFP1.

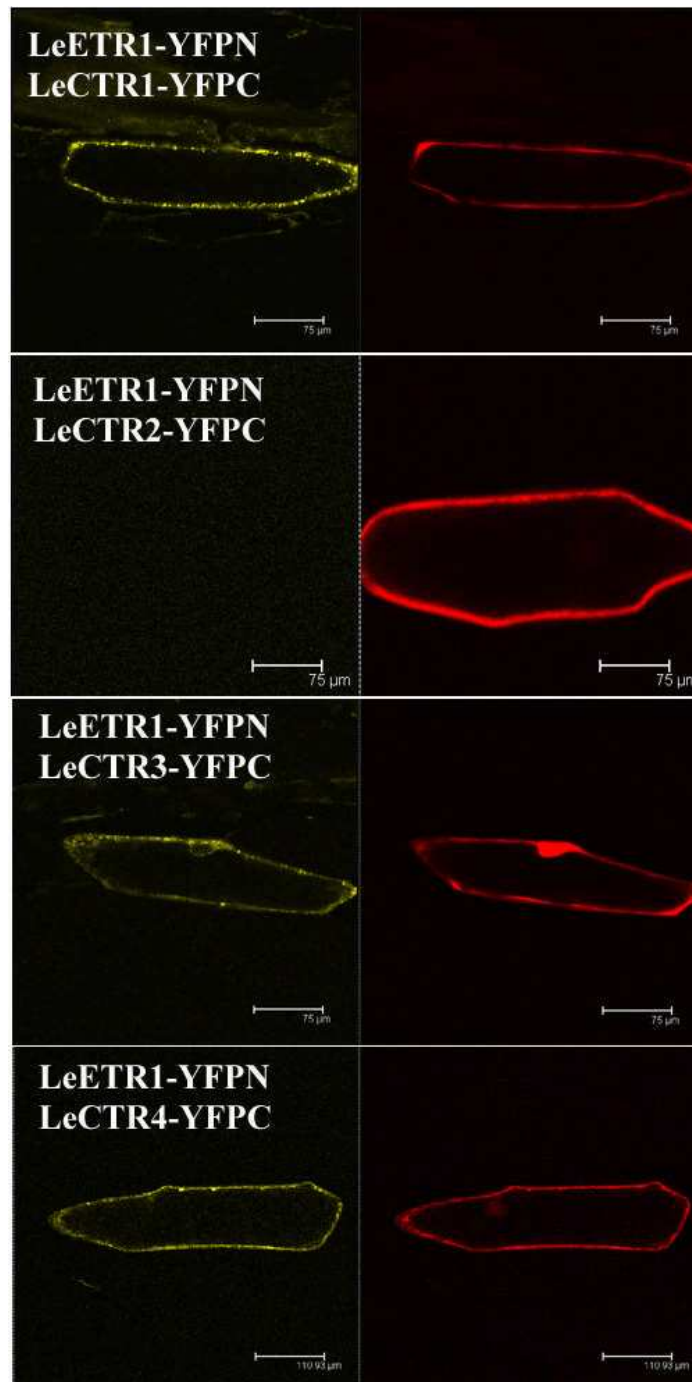

Figure 3.48: BiFC assay of the receptor ETR1 with 4 CTRs

Onion epidermal cells were co-transformed with three constructs: LeETR1-YFPN, CTR (1 to 4)-YFPC and mRFP1. The images of the BiFC channel (left) are shown in the colour yellow and the mRFP1 images (right) are indicator of successful transformation. YFPN/C: the N- and C-terminal fragment of YFP.

The tomato ethylene receptor ETR1 showed positive BiFC results with CTR1, CTR3 and CTR4, but not with LeCTR2 as indicated by the images of the BiFC channel (yellow).

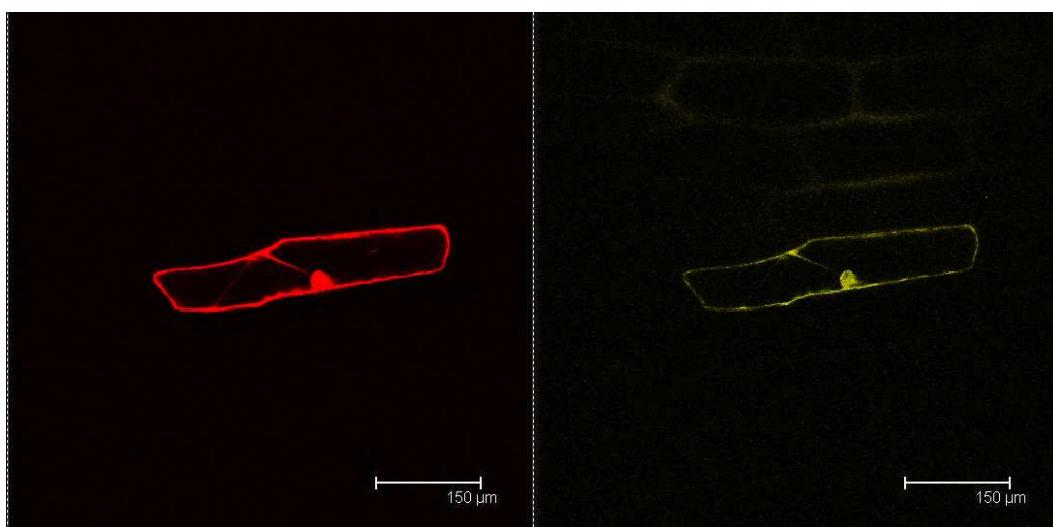

Figure 3.49: LeCTR2-YFPC showed positive BiFC with YFPN

An onion cell was co-transformed with three constructs: YFPN, CTR2-YFPC and mRFP1. The images of the BiFC channel (right) is shown in the colour yellow and the mRFP1 images (left) is the indicator of successful transformation.

The LeCTR2-YFPC construct previously showed no BiFC with the ethylene receptor NR and ETR1 (Figure 3.47 and 4.19). The BiFC between LeCTR2-YFPC and the positive control (YFPN) suggests that the LeCTR2 construct was functional and the LeCTR2-YFPC protein has been properly expressed.

3.11 Summary

In this study, three tomato ripening fruit cDNA clones (IntCR22, 242 and 266) obtained from yeast two-hybrid screens using LeCTR2 as bait (Lin and Grierson, unpublished data) were analyzed in order to understand the role of LeCTR2 in tomato ethylene signalling. Sequence analysis suggested that IntCR22 is a UDP-glycosyltransferase, IntCR242 is a putative homologue of the *Arabidopsis* AT1G15730 and IntCR266 is similar to the FtSH protease (Section 3.2). The expression patterns of the IntCR genes were then examined by northern blot assays (Section 3.3). It was shown that IntCR22 was down-regulated by light and induced by salicylic acid (Figure 3.7 and 3.9). Among the IntCR clones, IntCR242 showed the strongest interaction with ethylene receptor LeETR1 and kinase LeCTR2 (Lin and Grierson, unpublished data) and a His-rich region in the C-terminus of IntCR242 was found to be responsible for its interaction (Section 3.4). To investigate the function of IntCR266, it was expressed in the *Arabidopsis* FtSH5 loss-of-function mutant *var1-1* and restored the leaf variegation mutant phenotype (Figure 3.15). Protein sub-cellular localization studies suggested that IntCR242 and 266 were targeted to the chloroplast, while IntCR22 was localized in the cytoplasm when expressed in transgenic tobacco plants.

However, it has been shown that the *Arabidopsis* ethylene receptor and CTR proteins are localized to the ER (Section 1.2.6). The localization of tomato ethylene receptors and CTRs were therefore examined. Gateway cloning vectors for generating fluorescent protein fusions and a biolistic-mediated transient expression system were

established (Section 4.3). The tomato ethylene receptors (ETR1, NR and ETR4) and three of the LeCTR proteins (CTR1, 3 and 4) were indeed targeted to the ER when transiently expressed in onion epidermal cells (Section 4.4). BiFC assay also confirmed the protein-protein interaction between the tomato ethylene receptors ETR1 and these three LeCTRs (CTR1, 3 and 4) (Figure 3.46-49). It is unlikely that the chloroplastic IntCR proteins (IntCR242 and 266) could interact with the ER localized ethylene receptors and CTRs. In addition, FRET assay showed no interaction between the cytosolic IntCR22 and the LeCTR2 protein, which is the only tomato CTR localized in the cytoplasm. Therefore, IntCR clones could be false positive clones of the yeast two-hybrid screen.

CHAPTER 4: DISCUSSION

4.1 Background

Ethylene is a gaseous plant hormone that regulates many aspects of plant growth and development. Although the molecular basis of the ethylene signalling pathway has been clarified using the model plant *Arabidopsis*, research on ethylene has moved into crop species with agricultural importance, such as the tomato, and many other fruit species where ethylene is critically involved in the fruit ripening process. Tomato perceives ethylene by at least six membrane-bounded receptors and the ethylene signal is then transmitted to a family of downstream kinases (LeCTRs), whereas the “small” *Arabidopsis* has five ethylene receptors and only one downstream kinase (AtCTR1). Yeast two-hybrid assay has been used successfully to study the protein-protein interaction between *Arabidopsis* ethylene receptors and AtCTR1 (Clark *et al.*, 1998). Therefore, yeast two-hybrid screens have been carried out by researchers in the University of Nottingham to identify novel ethylene signalling components in tomato fruit (Lin and Grierson, unpublished data). The IntCR (Interacting with CTR2) clones were initially discovered by screening a yeast two-hybrid library prepared from tomato fruit RNA. Because it has been demonstrated that LeCTR2 is able to interact with the ethylene receptor LeETR1, these IntCR clones were subsequently examined for their ability to associate with LeETR1. Three of the IntCR clones (IntCR22, IntCR242 and IntCR266) could indeed interact with LeETR1 in the yeast two-hybrid assay (Lin *et al.*, 2003). To gain more insight into the ethylene signalling network in tomato, the functions and localization of these IntCR proteins were investigated in this study.

4.2 IntCR22

4.2.1 IntCR22 encodes a UDP-glycosyltransferase

The IntCR22 clone obtained from the yeast two-hybrid screen (Lin *et al.*, 2003) contains a 0.7 kb cDNA fragment which matches the 3' end of the tomato EST TC176700 (see section 1.3.4 for details). Analysis of the deduced amino acid sequence of the full-length IntCR22 suggests that it is a UDP-glycosyltransferase (UGT) (see section 3.2.3 for details). In *Arabidopsis* 107 UGTs have been identified and classified into 31 sub-families. IntCR22 shares sequence homology to the members of the *Arabidopsis* UGT73C sub-family (Figure 3.5).

There are two general experimental approaches to investigate the role of a UDP-glycosyltransferase. One is to alter the expression level of the gene encoding the target UGT and to analyze the phenotype of the transgenic plants. The alternative method utilizes the purified recombinant UGT proteins and studies their *in vitro* enzymatic activity. It would be difficult to use transgenic approaches to study the function of IntCR22. Firstly, the phenotype of the transgenic plant with altered IntCR22 expression might be masked by the functional redundancy of an unidentified tomato UGT. Without a comprehensive genome sequence such as those of the model plant *Arabidopsis*, it is difficult to estimate how many IntCR22-like genes are present in the tomato genome. For the same reason, we might not be able to rule out the possibility that the phenotypes of those transgenic plants with altered IntCR22 expression level resulted from co-silencing of genes sharing sequence homology to IntCR22.

The *in vitro* enzymatic assay approach also has its disadvantages. For example, the plant proteins synthesized and purified from yeast or *E. coli* might not be active due to the lack of essential co-factors or post-translational modifications. All the 107 UGT proteins in the model plant *Arabidopsis* have been synthesized and purified from *E. coli*; the substrates of only 16 *Arabidopsis* UGT proteins have been found (Bowles, *et al.*, 2005). IntCR22 shares sequence homology with the *Arabidopsis* UTG73C3 (AT2G36780), whose substrate specificity has not yet been reported. However, such an *in vitro* method has been used successfully to characterize two other members of the UGT73C family (Popenberger *et al.*, 2003; Hou *et al.*, 2004), and therefore, collaboration was formed with Dr. Francisco Borja Flores (Plant Sciences Division, University of Nottingham) to identify the *in vitro* enzymatic substrate of IntCR22 despite the aforementioned limitations.

It has been demonstrated that the crude total protein extract from the yeast expressing IntCR22 has higher UDP-glycosyltransferase activity than those expressing a negative control protein (Flores, unpublished data). This observation confirmed that the IntCR22 protein is a functional UGT and the next objective is to identify its substrate. The *in vitro* enzymatic activity of IntCR22 was subsequently examined against several plant growth regulators, including auxin, cytokinin and ABA. However, the preliminary results suggested that the plant growth regulators tested could not be glycosylated *in vitro* by the purified IntCR22 protein (Flores, unpublished data).

4.2.2 Possible biological functions of IntCR22

Although the IntCR22 protein showed no *in vitro* activity against zeatin in our study, it was considered possible that IntCR22 might be active against other substrates or, alternatively, possess a tissue specific UDP-glycosyltransferase activity. Thus, northern blot experiments were carried out to investigate where and how IntCR22 is expressed. Evidence from the previous research has demonstrated that the IntCR genes including IntCR22 were highly expressed in the ripening fruit (Lin *et al.*, 2003). In the recent study, northern blot assay showed that IntCR22 is also expressed in leaf and might have a rhythmic expression pattern (Figure 3.7). In addition, it was also shown that the IntCR22 mRNA accumulated in leaf 2 h after spraying the plant with 0.5 mM of salicylic acid (Figure 3.9). These findings suggest that the expression of IntCR22 is indeed regulated by developmental and environmental cues and it might also be involved in defence response. However, the puzzle of the unknown substrate of IntCR22 remains unsolved.

Evidence from a recent report shows that two members (C5 and C6) of the *Arabidopsis* UGT73C family could glycosylate zearalenone (ZON) when heterologously expressed in baker's yeast *Saccharomyces cerevisiae* (Poppenberger *et al.*, 2006). ZON is an oestrogenic metabolite produced by plant pathogenic fungi and could be inactivated through conjugation of a glucose moiety to form of ZON-4-O-Glc. As the expression of IntCR22 is regulated by SA, which is a phytohormone critically involved in defence

response (reviewed in Shah, 2003), it would be interesting to establish whether ZON is a substrate of the IntCR22 protein, although little is known about the function of ZON in plant-pathogen interaction. In a separate experiment, Bowles and her co-workers demonstrated the *in planta* glycosyltransferase activities of UGT73C5 against brassinosteroids (BRs) (Poppenberger *et al.*, 2005). Transgenic *Arabidopsis* plants over-expressing UGT73C5 showed BR-deficient phenotypes including small rosette leaf, reduced petiole length and inhibition of leaf elongation. The BR content was reduced in the UGT73C5 over-expressing lines and a higher level of 23-O-glucosyl conjugated BR was detected in feeding experiments when compared to wild-type (Poppenberger *et al.*, 2005). In addition, the phenotypes of the UGT73C5 over-expresser could be rescued by applying exogenous BR. Collectively, these findings suggested that UGT73C5 was involved in BR inactivation and over-expression of UGT73C5 resulted in BR deficiency. However, preliminary evidence from the transgenic tomato and *Arabidopsis* plants with altered IntCR22 levels suggested that the IntCR22 might have a different substrate specificity, despite its sequence homology with the *Arabidopsis* UGT73C5 (Flores, unpublished data). It is not surprising because although UGT73C5 shares sequence homology to other members of the UGT73C family, all of them appear to have distinct substrate specificities and the tomato IntCR22 might be a homologue of one of the uncharacterized UGT73C members.

It has been reported that the *Arabidopsis* mature dry seeds contain two types of modified zeatin (zeatin riboside and zeatin-O-glucoside), and zeatin riboside is the

predominant form of cytokinin in the wild-type seeds (Chiwocha *et al.*, 2005). Interestingly, the research conducted by Chiwocha and his co-workers also showed that zeatin-O-glucoside became the major cytokinin in the sub-family I ethylene receptor mutant *etr1-2* and the glycosyl-transferase responsible for this has not yet been identified. The tomato IntCR22 could interact with the ethylene receptor LeETR1 protein in the yeast two-hybrid assay (Lin and Grierson, unpublished data), which is the homologue of the *Arabidopsis* ETR1. It is possible that the *Arabidopsis* homologue of IntCR22 could also interact with the ethylene receptor AtETR1 and the interaction might affect its glycosyl-transferase activity, which causes the *etr1-2* mutant to accumulate more zeatin-O-glucoside. Further work will be required to establish whether IntCR22 is the UGT responsible for zeatin glycosylation. One possible experiment is to knockout the endogenous IntCR22 or LeETR1 in transgenic tomato plants using RNAi or antisense constructs, and to compare their glycosylated zeatin levels with the wild-type plants. Alternatively, transgenic plants over-expressing IntCR22 might also be used.

4.2.3 Sub-cellular localization of IntCR22

One of the unique characteristics of IntCR22 protein is its ability to interact with both the tomato ethylene receptor ETR1 and the putative downstream CTR1-like kinase LeCTR2 in the yeast two-hybrid assay (Lin *et al.*, 2003). As the tomato ethylene receptor ETR1 and LeCTR2 is believed to be histidine kinase and Ser/Thr kinase, respectively, it was thus hypothesized that LeETR1 and LeCTR2 might form a protein

complex with IntCR22 and the activity of IntCR22 could be regulated by protein-protein interaction. Therefore, protein localization studies were carried out to investigate whether the ethylene receptor LeETR1, the putative downstream kinase LeCTR2 and IntCR22 would co-localize by expressing recombinant proteins fused to fluorescent protein.

The localization experiment showed that both the tomato IntCR22 and one of its putative *Arabidopsis* homologue (UGT73C3, AT2G36780) are targeted to the cytoplasm and nucleus in the transgenic tobacco plants (see section 3.6.3 for details). However, the ethylene receptors and CTRs are believed to be ER proteins as the *Arabidopsis* ethylene receptor ETR1 and CTR1 have been found in the ER by immuno-localization experiments (Chen *et al.*, 2002; Gao *et al.*, 2003). Therefore, the localization of the tomato ethylene receptor and CTRs were investigated by using a transient expression system (see section 3.9 for details). Evidence from the transient expression experiments show that LeETR1 is indeed targeted to the ER (Figure 3.42). LeCTR2 was found in the cytoplasm and nucleus and co-localized with IntCR22 when transiently expressed in onion cells (Figure 3.26 and 3.27). These suggested that IntCR22 has the potential to interact with LeCTR2 and however, a key question is whether, and how, the ER membrane-bounded LeETR1 could associate with the cytosolic IntCR22.

The recently published melon ethylene receptor CmERS1 topology model suggests that the three N-terminal transmembrane domains of the receptor are anchored to the ER

membrane and the C-terminal domain is exposed to the cytoplasmic side of the ER (Figure 1.6; Ma *et al.*, 2006). The yeast two-hybrid assay showed that IntCR22 interacts with the C-terminal domain of ethylene receptor LeETR1 (Lin *et al.*, 2003). Thus, it is reasonable to suggest that if LeETR1 have the same membrane topology as the melon CmERS1, the C-terminus of LeETR1 could be able to associate with the cytosolic IntCR22. Additionally, evidence from this study shows that the tomato ethylene receptor NEVER-RIPE (NR), which falls into the same category of receiver domain minus sub-family I ethylene receptor as the aforementioned CmERS1, is able to mediate the ER localization of LeCTR1, 3 and 4 (see section 3.10.2 for details). Most importantly, the LeCTR proteins adopt a cytosolic localization pattern unless they were expressed with the ethylene receptor NR (Figure 3.43, 4.15). It is also in agreement with the observation that the *Arabidopsis* CTR1 dissociated from the ER membrane in the absence of the ethylene receptors (Gao *et al.*, 2003). Thus, there is reason to believe that proper localization of IntCR22 to the ER membrane might also require the presence of ethylene receptors such as LeETR1. On the other hand, despite the fact that IntCR22 could associate with both LeETR1 and LeCTR2 in the yeast two-hybrid assay, it has to be borne in mind that these protein-protein interactions might not be able to take place *in vivo*, as the yeast two-hybrid screen could generate false positive results. Therefore further experiments were required to confirm their *in planta* protein interactions.

4.3. IntCR266 and IntCR242

4.3.1 IntCR266 is a functional chloroplast FtSH proteinase

The deduced amino acid sequence of IntCR266 shares 80% homology to the *Arabidopsis* chloroplast metallo-proteinase FtSH5/VAR1 (Figure 3.4). It has been reported that AtFtSH5/VAR1 is involved in degradation of photo-damaged proteins in the thylakoid membrane and the loss-of-function mutant of AtFtSH5/VAR1 has a leaf variegation phenotype (Sakamoto *et al.*, 2002). The protein localization study using transgenic tobacco plants expressing IntCR266 fused to GFP showed that IntCR266 is indeed targeted to the chloroplast (Figure 3.19). Therefore, it was hypothesized that IntCR266 could be a tomato homologue of AtFtSH5/VAR1.

In order to study the biological function of IntCR266, a mutant complementation experiment was carried out. The full-length cDNA of IntCR266 under the control of a CaMV35S promoter was transformed into *Arabidopsis* FtSH5/VAR1 loss-of-function mutant *var1-1*. The IntCR266 transgene complemented the variegation phenotype of the *var1-1* mutant in three independent transgenic lines (Figure 3.15). This suggested that IntCR266 was a functional chloroplast FtSH proteinase homologous to the *Arabidopsis* FtSH5. However, the ethylene receptors including AtETR1, CmERS1 and three tomato ones (ETR1, NR and ETR4) have all been located to the ER (Figure 3.26, 4.10 and 4.11; Chen *et al.*, 2002; Ma *et al.*, 2006). Thus, the chloroplastic IntCR266 protein is unlikely to be able to associate with the ethylene receptors. The interaction detected in the yeast two-hybrid assay might therefore be a false positive result.

4.3.2 IntCR242 is also a chloroplast protein

IntCR242 also contains an N-terminal chloroplast transit peptide (cTP) and the full-length protein was predicted to be targeted to the chloroplast (see section 3.2.2 for details). The two *Arabidopsis* proteins (accession number: AT1G15730 and AT1G80480) sharing sequence homology (70% identity) to IntCR242 have been found in the plastid stroma according to the recently published plastid proteome database (<http://ppdb.tc.cornell.edu/default.aspx>). Therefore, experiments were carried out to investigate the sub-cellular localization of IntCR242. A chimeric construct expressing IntCR242 fused to GFP was generated and transformed to tobacco. Analysis of the transgenic tobacco expressing IntCR242-GFP confirmed that IntCR242 is indeed targeted to the chloroplasts (Figure 3.17 to 3.19).

Collectively, evidence from the protein localization studies suggest that both the IntCR242 and IntCR266 proteins are targeted to chloroplasts, which is an unlikely localization for proteins that could associate with ethylene receptors in the ER. However, it has been recently discovered that some chloroplastic proteins utilize the ER secretion pathway to enter chloroplasts (Radhamony and Theg 2006). It is hypothesized that those proteins do not have the traditional chloroplast transit peptide (cTP) but an ER-signal sequence followed by a cTP-like region. The ER-signal sequence would be removed during or after the secretion and the hidden cTP would be exposed to the chloroplast import mechanism. However, both IntCR242 and IntCR266 have the traditional cTP in their N-termini; therefore they are not likely to enter chloroplasts through the ER.

4.3.3 Are the IntCR clones artefacts of the yeast two-hybrid screen?

The yeast two-hybrid system is a simple and high-throughput technique to screen for partners of a specific protein without previous knowledge of the potential interactions (reviewed in Bartel and Fields, 1997). However, yeast two-hybrid screens generate a significant number of artefact interactions; they are referred to as false positives (Stephens and Banting, 2000; Serebriiskii *et al.*, 2000; Vidalain *et al.*, 2003). The false positives are classified into two categories: technical false positive and biological false positive. The former class consists of proteins that could not interact with the protein of interest (POI), but their expression in the yeast cell could switch on the reporter genes. Proteins with DNA binding capacity such as transcription factors are common technical false positives identified from the yeast two-hybrid screens. The biological false positives are proteins that indeed interact with POI in the yeast cell, but the protein-protein interactions are implausible or impossible to occur *in vivo* in the organism of study.

One criterion to eliminate false positives is to investigate whether or not the identified protein and the POI are expressed in the same time, same tissue and have the same sub-cellular localization. It has been shown that the IntCR, ethylene receptor ETR1 and LeCTR2 are indeed highly expressed in tomato fruit and their transcripts are particularly abundant in ripening tissues (Lin *et al.*, 2003) suggesting they match the first criterion of the true interacting protein. In the protein localization study, however, the IntCR242 and IntCR266 proteins are targeted to chloroplasts, whereas the ethylene receptors are

expected to be localized in ER. Therefore, the IntCR242 and IntCR266 clones might be biological false positives of the yeast two-hybrid screen.

Among the IntCR clones, IntCR242 showed the strongest protein-protein association with the tomato ethylene receptor ETR1 and the putative downstream kinase LeCTR2 (Lin *et al.*, 2003). A deletion yeast two-hybrid assay was then performed to identify the domain responsible for this interaction. It was mapped to a histidine-rich (His-rich) region in the C-terminus of IntCR242, which contains 14 His-Asp repeats and 4 His-Glu repeats (Figure 3.12). Both aspartic acid and glutamic acid contain negatively charged side chains. In addition, this His-rich region is also able to interact with all other IntCR proteins in the yeast two-hybrid assay, which suggests it could be a sticky protein (Figure 3.13). Thus, it seems likely that the negatively charged His-rich region is responsible for IntCR242's random interaction with multiple biologically irrelevant proteins, in which case IntCR242 is a biological false positive of the yeast two-hybrid screen.

4.4 Interaction between Tomato Ethylene Receptors and CTRs

4.4.1 Mutation in the CN motif of LeCTR2 does not abolish its interaction

It has been shown that the putative Ser/Thr kinase LeCTR2 interacted with both the tomato ethylene receptors ETR1 and ETR2 in the yeast two-hybrid assay (Lin *et al.*, 2003). Because LeCTR2 failed to co-localize with the ethylene receptor ETR1 (Figure

3.26 and 3.27), the interaction between LeCTR2 and the tomato ethylene receptors was therefore re-examined. It has been reported that interaction between the *Arabidopsis* CTR1 and ETR1 was abolished by mutation in the conserved CN motif (Huang *et al.*, 2003). It was thus reasoned that if LeCTR2 is a true interacting partner of LeETR1, the same mutation in the CN box would disrupt their association. However, when the CN motif mutation was introduced to LeCTR2 by PCR mutagenesis (Figure 3.30), the mutated LeCTR2 still interacted with the tomato ethylene receptors in the yeast two-hybrid assay (Figure 3.31).

The aforementioned yeast two-hybrid assays were carried out using the LexA-based yeast two-hybrid system - the same system used to generate the two IntCR clones that are likely to be false positives. Therefore, a more stringent yeast two-hybrid system based on GAL4 transcription factor (ProQuest, Invitrogen) was used to study the interaction between LeCTR2 and the ethylene receptors (see section 3.8.2 for details). The ProQuest yeast two-hybrid system showed that LeCTR2 could not associate with the ethylene receptors (LeETR1 and LeETR2), while the *Arabidopsis* CTR1 showed strong interaction with the ethylene receptor AtETR1 in a control experiment (Figure 3.32). Additionally, in the Gal4-based yeast two-hybrid system, the Gly³⁴⁷ to Glu mutation in the CN motif of LeCTR3 abolished its interaction with the tomato ethylene receptors (LeETR1, LeETR2 and NR), which confirmed the previous hypothesis that mutation in the CN motif of the tomato CTRs could interrupt their interaction with the ethylene receptors (Figure 3.34). These observations suggested that the

LeCTR2-LeETR1 interaction might be a false positive of the yeast two-hybrid. However, *in vivo* evidence was still needed to confirm the yeast two-hybrid assay results. As Gao *et al.* (2003) demonstrated that the endoplasmic reticulum localization of AtCTR1 requires the presence of ethylene receptors, it was proposed to investigate the tomato ethylene receptor-CTR interaction through analyzing their protein localization.

4.4.2 Receptor NR dependent localization of LeCTR1, 3 and 4 in onion cells

Efforts to visualize the full-length tomato ethylene receptor or CTR fused to GFP in transgenic plants were not successful (see section 3.7.1 and 4.4.1 for details). Similar experiments to study localization of the *Arabidopsis* ethylene receptors and CTR have also been reported to be problematic (Chen *et al.*, 2003; Gao *et al.*, 2003), while a recent report demonstrated that a melon ethylene receptor CmERS1 fused to GFP could be expressed and visualized through biolistic-mediated transient expression (Ma *et al.*, 2006). Therefore a transient expression system was developed to express the tomato ethylene receptors and CTRs fused to fluorescent protein (see section 3.8 for details).

Using the transient expression system, the tomato ethylene receptor ETR1, NEVER-RIPE and ETR4 were found to be targeted to the endoplasmic reticulum (ER) when transiently expressed in onion cells (Figure 3.39 to 4.13). The putative downstream kinases (LeCTR1, 3 and 4) were located in the cytoplasm and nucleus (Figure 3.43 and 4.16). However, when the ethylene receptor NR was co-expressed in

the same cell, the CTR proteins moved to the cortical ER network and co-localized with the ethylene receptor (Figure 3.44). This receptor dependent localization of CTR supports the results from the previous yeast two-hybrid assay that LeCTR1, 3 and 4 could interact with the ethylene receptor (Lin and Grierson, unpublished data) and is also in agreement with the receptor-mediated CTR1 localization model in *Arabidopsis* (Gao *et al.*, 2003).

On the other hand, LeCTR2 could not co-localize with the ethylene receptor NR in the ER when they were co-expressed in onion cell (Figure 3.44). This again is consistent with the evidence from the yeast two-hybrid assay (Figure 3.31) and previous researches carried out in the University of Nottingham that LeCTR2 has no protein-protein interaction with the receptor NR (Lin and Grierson, unpublished data).

However, prolonged expression of ethylene receptor NR led to formation of the aggregation bodies (Figure 3.41). Additionally, the full-length ethylene receptors LeETR1 and LeETR2, which might interact with LeCTR2, could not be transiently expressed in onion cell due to strong aggregation (data not shown). The truncated N-terminus of the ethylene receptor LeETR1 fused to GFP could, however, be transiently expressed and targeted to the ER (Figure 3.42). It has been reported that transient expression of the full-length *Arabidopsis* ethylene receptor ETR1 also resulted in protein aggregation (Chen *et al.*, 2002). Thus, the results presented in this study, in line with the *Arabidopsis* research suggest the hypothesis that the ethylene receptors

tend to aggregate when expressed at a non-biologically high level. But yet, we do not have an explanation for these data. Since the protein-protein interaction involving LeETR1 and LeCTR2 could not be investigated by fluorescent protein localization study, efforts were made to use alternative fluorescent protein-based approaches such as Forster Resonance Energy Transfer (FRET) and Biomolecular Fluorescence Complementation (BiFC).

4.4.3 Forster Resonance Energy Transfer (FRET)

It was initially attempted to use FRET to characterize the *in vivo* ethylene receptor-CTR interaction (see section 3.1.2 for details). However, efforts to measure FRET between the ethylene receptor and CTR were not successful (data not shown). The measurement of FRET from a positive control ruled out the possibility of equipment failure or faulty experimental design (Figure 3.29). Therefore, two non-mutually exclusive hypotheses were suggested to explain the lack of FRET between the ethylene receptors and CTRs.

1) No FRET between ETR and CTR

FRET is a non-radiation energy transfer phenomenon between two interacting dipoles. It has a strong distance dependence (in Angstrom scale), such that the efficiency of FRET varies as the inverse of the sixth power of the distance that separates the donor and acceptor fluorescent proteins, as described by

$$\text{FRET Efficiency} = 1/[1 + (r/R_0)^6]$$

Where r is the distance between two fluorochromes and R_0 is the Forster distance, which

is proximally 4.9 to 5 nm for the CFP and YFP pair. It is generally considered that it would be difficult to measure FRET with efficiency less than 10% using intensity-based FRET methods (Periasamy and Day, 2005). In a CFP-YFP FRET experiment with efficiency factor larger than 10%, the distance r would have to be less than $1.44 R_0$, which is about 8 nm. The fluorescent proteins themselves are about 3 nm in width (Shaner *et al.*, 2005). Therefore if the distance between ETR and CTR is larger than 5 nm, FRET would be either undetectable or prohibited (Figure 4.1 b). Furthermore, FRET also has a strict angular dependence; it would not occur if the receptor-CTR complex adopts a non-favourable orientation (Figure 4.1 c). In addition, both the ethylene receptor and CTR were cloned into gateway compatible pDestination vectors (Figure 3.37) to acquire the fluorescent protein fusion. In such a case, an 18 amino acids peptide linker, which is encoded by the gateway att recombination site, would be used to join the protein of interest and the fluorescent protein. Although this linker sequence is present in any commercially available gateway vectors, the length and the relative orientation of the linkers might prevent FRET from taking place.

2) Presence of non-interacting proteins

In an intensity-based FRET measurement such as acceptor photo-bleaching FRET, which compares the donor fluorescence in the presence and absence of the acceptor, the FRET efficiency is calculated by dividing the change of donor fluorescence intensity by the donor fluorescence intensity before bleaching the acceptor as

$$\text{Efficiency} = (D_{\text{post}} - D_{\text{pre}}) / D_{\text{post}}$$

Where D_{pre} and D_{post} are the donor fluorescence intensity before and after photo-bleaching the acceptor. It is reasoned that if the donor is a mixture of interacting and non-interacting proteins, the detected FRET efficiency would be reduced directly proportionally to the amount of those non-interacting donor proteins. For example, if 90% of the ethylene receptors did not take part in the interaction with CTR, the observed FRET efficiency would be 10% of the real value and might not be detected.

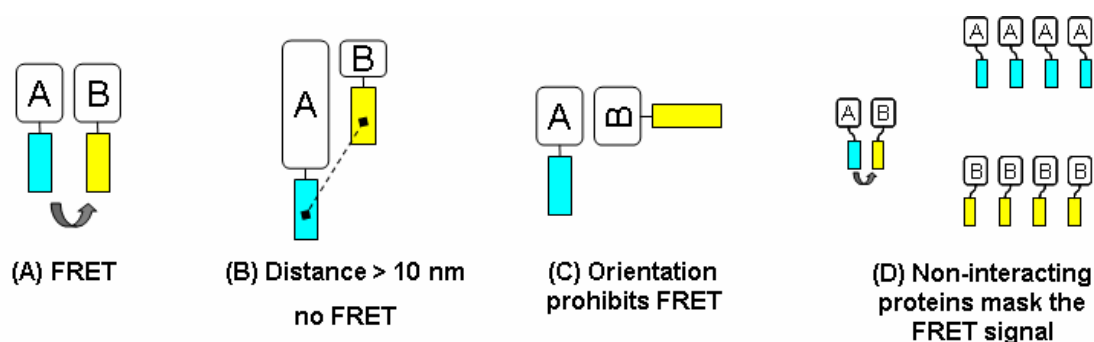

Figure 4.1: Schematic diagram of FRET between two interacting proteins

The associating protein A and B is fused to CFP (cyan rectangle) and YFP (yellow rectangle), respectively. (A): The distance and orientation favour FRET to occur. (B) and (C): The distance and orientation prohibits FRET although the two target proteins are interacting. (D): FRET does occur, the signal, however is mixed with the fluorescent from the non-interacting proteins as may be difficult to detect.

4.4.4 Biomolecular Fluorescence Complementation (BiFC)

BiFC is an alternative experimental approach for *in vivo* visualization of protein-protein interaction, which is based on the formation of a functional fluorescent complex by two non-fluorescent fragments (Hu *et al.*, 2002). For example, the N-terminal domain of YFP (nYFP, aa 1-155) and the C-terminal domain of YFP (cYFP, aa 156-238) do not

emit fluorescence on their own, unless they can be brought together by other forces to form a new YFP complex (Hu and Kerppola 2003). In the case of BiFC, the nYFP and cYFP fragments were fused to two proteins of interest (POI). It was reasoned that when the two interacting POI (fused to either nYFP or cYFP) were expressed simultaneously in a single cell, such as a onion epidermal cell, the fluorescent protein fragments (n/cYFP) could be brought together by the interaction of POI and form an YFP complex capable of emitting light when excited with a 514 nm laser. On the other hand, if the two POI could not associate with each other, the FP fragments fused to the POI could not regenerate the YFP and thus no fluorescent emission would be detected.

The formation of a BiFC fluorescent complex is a two stage process (Figure 4.2 a). The initial step is mediated by interaction of the POI fused to the fluorescent protein fragments, which is the N- or C-terminal domain of the YFP variant Venus in this study (see section 3.9.3 for details). Once the initial POI complex is formed, the N- and C-terminal fragments of YFP may self-assemble into a functional YFP. As this YFP regeneration process is irreversible, the protein complex is stabilized permanently. This then allows visualization of transient (kinetic) protein-protein interactions (Figure 4.2 b), which could not be detected by FRET. Thus, if the ethylene receptor-CTR interaction could be stabilized, the problem of ethylene receptor protein aggregation, which hampers the FRET measurement, would therefore be circumvented. It has also been suggested that through employing a flexible linker peptide between the target protein and the YFP fragment (Figure 4.2 c), BiFC could be used to visualize long distant

protein interaction of greater than 10 nm, which is beyond the detection limit of FRET (Hu *et al.*, 2002).

4.4.5 BiFC assay reveals the interaction between receptors and CTRs

A series of cloning vectors has been generated to express target proteins fused to N- or C-terminal fragments of YFP for BiFC analysis (see section 3.9.3 for details). Because BiFC is a novel technique and has not yet been widely used to visualize protein interaction in living plant cells, a control experiment was carried out to evaluate the applicability of BiFC for studying ethylene receptor-CTR interaction. The ethylene receptor NEVER-RIPE is known to associate with the putative downstream kinase LeCTR1 but not with LeCTR2 in the yeast two-hybrid assay (Figure 3.31; Lin and Grierson, unpublished data). Moreover, protein co-localization studies confirmed that NR could associate with LeCTR1 but not LeCTR2 (Figure 3.44). Therefore, the control BiFC assay was performed by transiently expressing NR fused to the N-terminus of YFP (referred to as NR-YFPN) and CTR fused to the C-terminus of YFP (referred to as LeCTR-YFPC) in onion epidermal cells. Whereas cells transformed with NR-YFPN and LeCTR2-YFPC showed no BiFC signal, a strong fluorescence was observed when NR-YFPN was co-expressed with LeCTR1-YFPC (Figure 3.46). This showed that BiFC could be used to visualize the ethylene receptor-CTR interactions.

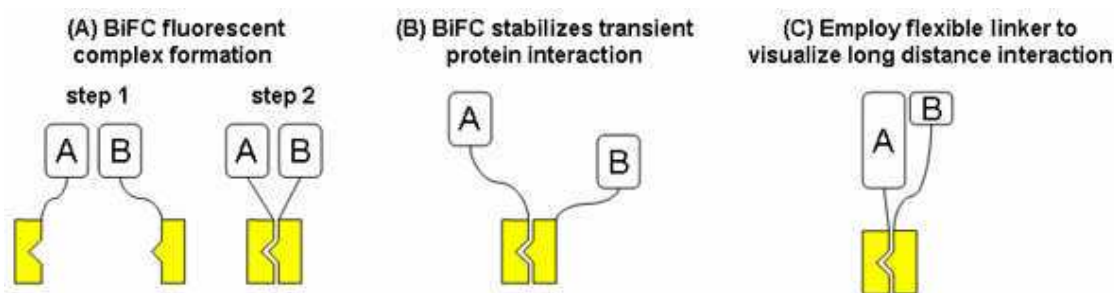

Figure 4.2: Schematic diagram of BiFC between two interaction proteins

Each of the two interacting proteins (presented as rectangles labelled A and B) is fused to the N- and C-terminal fragment of YFP (indicated by the yellow interlocking rectangles).

(A) Two-step process of BiFC complex formation. Protein A and B first interact (step 1) and bring the two YFP fragments close enough to form a complete YFP protein (step 2). Neither fragment is fluorescent on their own unless they are brought together to form a complete YFP by the association between protein A and B. Therefore, no YFP fluorescent would be detected if protein A and B did not interact.

(B) The process of regenerating YFP from the two BiFC fragments is irreversible. Therefore, the BiFC signal is still present after the dissociation of protein A and B, which enable BiFC to visualize transient protein-protein interactions.

(C) Increasing the length and flexibility of the linker peptide joining protein B and the fluorescent protein fragment enables BiFC to occur over a longer distance.

To investigate the *in vivo* protein-protein interaction between the ethylene receptor LeETR1 and the four putative downstream Ser/Thr kinases (LeCTR1 to 4), onion cells were transformed with combinations of these constructs. The BiFC assay indicated that all LeCTRs except for LeCTR2 showed strong BiFC signals when co-expressed with the ethylene receptor LeETR1 (Figure 3.48). This suggests LeETR1 is indeed capable of interacting with CTR1, CTR3 and CTR4 with the exception of CTR2. This is in agreement with the previous report that expression of LeCTR1, 3 and 4 in the *Arabidopsis CTR1* loss-of-function mutant could rescue the *ctr1-8* mutant phenotype (Adams-Phillips *et al.*, 2004). But the problem remained: why LeCTR2 could not

associate with LeETR1 in the BiFC experiment, whilst it could interact in yeast using a LexA-based yeast two-hybrid system (Figure 3.31). The key question is could the LeCTR2-LeETR1 interaction again be a false positive result of the yeast two-hybrid?

4.4.6 Tomato ethylene receptor-CTR interaction: an overview

It has been reported that the *Arabidopsis* sub-family I ethylene receptors (AtETR1, AtERS1) have protein-protein interactions with the downstream Ser/Thr kinase AtCTR1 (Clark *et al.*, 1998; Huang *et al.*, 2003). In tomato, there are at least three sub-family I receptors (LeETR1, LeETR2 and NR) and four CTR1-like proteins (LeCTR1 to 4). Protein localization and interaction results presented in this study, in line with previous research in the University of Nottingham suggested a more complicated receptor-CTR interaction network present in tomato. Four methods have been used to investigate the tomato ethylene receptor-CTR interaction and generated different results.

- 1) Yeast two-hybrid system based on LexA
- 2) Yeast two-hybrid system based on Gal4
- 3) Fluorescent protein-assisted localization study
- 4) Biomolecular fluorescence complementation (BiFC)

Evidence from the LexA-based yeast two-hybrid assay suggested that all four LeCTRs could interact with the receiver domain containing subfamily I receptor LeETR1 and

LeETR2 (Table 5.1), whereas, the ethylene receptor NR, which does not contain the receiver domain, could only interact with three CTRs (CTR1, 3 and 4) in this LexA-based yeast two-hybrid system (Figure 3.31). On the other hand, the more stringent Gal4-based yeast two-hybrid system (ProQuest, Invitrogen) could only detect the protein-protein interaction between LeCTR3 and the sub-family I ethylene receptors (Figure 3.33). More importantly, the LexA-based yeast two-hybrid system failed to distinguish the difference between LeCTR2 with the wild-type and mutated CN motif (Figure 3.31). Previous research has shown that this CN motif mutation in *Arabidopsis* CTR1 could disrupt its interaction with the ethylene receptors (Huang *et al.*, 2003). Consistently, the interactions of LeCTR3 with the ethylene receptors in the Gal4-based yeast two-hybrid system were abolished when its CN motif was artificially mutated (Figure 3.34). It is therefore hypothesized that the conflicting yeast two-hybrid results are due to the variation in stringency of the two yeast two-hybrid systems.

Initially, Chang *et al.* (1998) demonstrated the *Arabidopsis* ETR1-CTR1 interaction using a LexA-based yeast two-hybrid system, in which the reporter gene is integrated into the yeast genome. On the other hand, the reporter gene of the LexA-based yeast two-hybrid system used for the LeCTR2-LeETR1 interaction assay in this study is located in a high copy-number plasmid pSH18-34 (Lin *et al.*, 2003). Genome integrated reporter genes are also adapted in the Gal4-based ProQuest yeast two-hybrid system (Invitrogen), which was used to re-examine the tomato ethylene receptor-CTR interaction. In addition, the ProQuest system uses low copy number plasmids to express

recombinant protein in yeast, whilst high copy number plasmids are used in both LexA-based systems. Therefore, it is generally considered that the Gal4-based system is more stringent than the LexA-based ones (Crickinge and Beyaert, 1999). In addition, the LexA-based yeast two-hybrid system used in this study is more sensitive than the one used by Chang *et al.* (1998) for the *Arabidopsis* ETR1-CTR1 interaction because of the difference in reporter gene copy numbers.

Besides using yeast two-hybrid assays, *in planta* fluorescent protein-assisted protein localization studies were also used to investigate the tomato ethylene receptor-CTR interaction. By analyzing the differences in sub-cellular localization of CTRs when transiently expressed in onion cells with or without the ethylene receptor NR, it was possible to confirm that NR has protein-protein interactions with three CTRs (CTR1, CTR3 and CTR4). Further evidence from BiFC suggested that the tomato ethylene receptor ETR1 also interacts with CTR1, CTR3 and CTR4, but not CTR2 (Table 5.2). Collectively, the *in vivo* fluorescent protein-based studies generated a more plausible ethylene receptor-CTR interaction pattern compared to those obtained from the yeast two-hybrid experiments, presumably because, as discussed above, yeast two-hybrid has the potential to generate false positive results. But when stringent yeast two-hybrid systems are used, weak interactions of biological significance may be missed.

A previous study on the *Arabidopsis* mutant *ctr1-8* has shown that tomato CTR1, CTR3 and CTR4 were capable of complementing the loss-of-function *CTR1* and rescued the

constitutive ethylene response mutant phenotype (Adams-Phillips *et al.*, 2004). It has also been shown that silencing the *LeCTR1* gene in tomato seedlings by virus-induced gene silencing (VIGS) could cause a constitutive ethylene response-like phenotype and activate the ethylene responsive genes, whereas no phenotype was observed from the plants with reduced *LeCTR2* mRNA level (Liu *et al.*, 2002). These results from other studies, in line with the findings presented in this study, support the involvements of *LeCTR1*, *LeCTR3* and *LeCTR4* in the tomato ethylene signalling network. In addition, it is the first time that fluorescent proteins have been used to visualize the tomato ethylene receptor-CTR protein complex in the endoplasmic reticulum, to which they have long been hypothesized to be targeted. However, whether or not *LeCTR2* is a CTR1-like kinase acting downstream of the ethylene receptors in the tomato ethylene signalling network remains unsolved.

Table 4.1: Comparison of the LexA- and Gal4-based yeast two-hybrid systems

LexA-based yeast two-hybrid assay				Gal4-based yeast two-hybrid assay			
bait prey	ETR1	ETR2	NR	bait prey	ETR1	ETR2	NR
CTR1	Yes	Yes	Yes	CTR1	No	No	No
CTR2	Yes	Yes	No	CTR2	No	No	No
CTR3	Yes	Yes	Yes	CTR3	Yes	Yes	Yes
CTR4	Yes	Yes	Yes	CTR4	No	No	No
Failed to distinguish the CN motif mutation in LeCTR2				Able to distinguish the CN motif mutation in LeCTR3			

The protein-protein interaction between the tomato sub-family I ethylene receptor and the four CTRs were examined by using the LexA- and Gal4-based yeast two-hybrid systems. The positive interaction detected by the yeast two-hybrid assay is indicated by “Yes” and lack of interaction by “No”. Part of the LexA-based yeast two-hybrid interaction results involving CTR1, CTR3 and CTR4 were kindly provided by Dr. Zhefeng Lin.

Table 4.2: Ethylene receptor-CTR interactions confirmed by fluorescent protein based methods

	ETR1	NR
CTR1	Yes	Yes
CTR2	No	No
CTR3	Yes	Yes
CTR4	Yes	Yes

The four CTRs fused to fluorescent protein were found in cytoplasm and nucleus when transiently expressed alone in onion epidermal cells. Changes of CTR1, CTR3 and CTR4 localization to the ER were observed when they were co-expressed with the ethylene receptor NR. This suggests CTR1, 3 and 4 interact with NR and the interaction is crucial for their localization. BiFC assay showed that the tomato ethylene receptor ETR1 could interact with CTR1, 3 and 4 but not CTR2.

4.6 Future Work

In this study, a reverse genetic approach was used to investigate the ethylene signalling events in tomato fruit in collaboration with colleagues in Grierson's research group. Firstly, we characterized clones (IntCR) isolated from a yeast two-hybrid library enriched in ripening fruit cDNA. The function of the IntCR266 clone was first revealed by *Arabidopsis* mutant complementation experiments and it turned out to be a chloroplast FtSH protein involved in repairing the photo-damaged PSII in the chloroplast. The endoplasmic reticulum localization of the ethylene receptors and CTRs makes it very unlikely that they could associate with the chloroplast-located IntCR242 and IntCR266. Although it is possible for some protein to enter chloroplast via the ER, the two IntCR proteins lack the appropriate signal sequence for this. Therefore, the IntCR242 and 266 clones are probably false positives of the yeast two-hybrid screen.

The IntCR22 protein was shown to be a cytosolic UDP-glycosyltransferase, although a more detailed enzymatic assay would be required to identify its enzymatic substrate. One interesting observation is that the IntCR22 expression appears to be down-regulated by light (Figure 3.7 and 3.8). It is also possible that the changes of IntCR22 mRNA level are controlled by the circadian clock instead of light. A further experiment would be to subject the wild-type tomato plant to sudden light or dark changes and monitor the IntCR mRNA level by northern blot. If the expression pattern of IntCR22 remained unchanged, it would be more likely to be regulated by the circadian clock. On the other hand, if the mRNA level of IntCR22 could respond rapidly

to the sudden light-dark switches, an experiment could be done to measure the half-life of IntCR22 mRNA and to use the phytochrome and cytochrome mutants to further establish the relationship between IntCR22 and light sensing. IntCR22 is also up-regulated by salicylic acid (SA) treatment (Figure 3.9), which plays an important role in mediating the plant defense response. Therefore, it would be very interesting to test whether or not silencing IntCR22 by introducing an RNAi or antisense construct to wild-type tomato plants would have an effect on the pathogen responses.

In order to study the *in vivo* protein-protein interaction and localization of tomato ethylene receptors, a transient expression system was established and cloning vectors for expressing target proteins fused to GFP variants were generated. The localization and protein-protein interaction results presented here in this study suggested that the ethylene receptors LeETR1, NR and LeETR4 were all targeted to the ER together with three downstream kinases (LeCTR1, LeCTR3 and LeCTR4) possibly as a receptor-CTR protein complex. Although, FRET between receptor and CTR could not be detected by the traditional intensity-based FRET method, the fluorescence lifetime measurement FRET (FLIM-FRET) could be used to quantify the receptor-CTR interaction in the future. In addition, a series of cloning vectors and a BiFC system has been established to visualize the protein-protein interaction between the tomato ethylene receptor ETR1 and CTRs. It is therefore possible to combine FRET with BiFC to investigate whether CTR binds to a receptor hetero- or homo-dimer in the ER membrane. This could be achieved by expressing two ethylene receptors fused to BiFC fragments, which generate

the YFP fluorescence when the ethylene receptors dimerize. The downstream CTR fused to CFP could be expressed simultaneously in the same cell, where a FRET signal could only be generated by energy transfer from CTR-CFP to the YFP in the receptor dimer BiFC complex.

However, the role of LeCTR2 remains elusive as conflicting results have been obtained from different yeast two-hybrid systems with different degrees of sensitivity. It appears that the tomato CTR2 might not be involved directly in ethylene signalling. The *Arabidopsis* EDR1 is a putative homolog of CTR2 due to the sequence similarity between CTR2 and EDR1 (Figure 1.11) and EDR1 is involved in both pathogen and ethylene signalling (Frye *et al.*, 1998; Frye *et al.*, 2001; Tang *et al.*, 2005). To gain more insight into the role of LeCTR2, further experiments would be required to establish the signalling event downstream from LeCTR2, possibly by attempting to use LeCTR2 to complement the *Arabidopsis* EDR1 or CTR1 loss-of-function mutant and to generate LeCTR2 knockout transgenic tomato plants. Preliminary evidence from the *Arabidopsis* mutant complementation experiment showed that the LeCTR2 cDNA under the control of CaMV35S promoter could complement neither *edr1* nor *ctr1* mutant possibly due to post-transcriptional gene silencing (data not shown). On the other hand, wild-type *Arabidopsis* transformed with the 35S:LeCTR2 construct displayed phenotypes resembling the *edr1* mutant, although they are preliminary results that require confirmation (Appendix). In addition, a chimeric construct with the EDR1 promoter fused to either *LeCTR2* genomic DNA or cDNA could be generated and used in *edr1*

mutant complementation experiments.

The protein localization experiments presented in this study showed that the ethylene receptor-CTR complex and the EIN2 protein are all located in the endoplasmic reticulum (Figure 3.26, 4.10 to 4.15). On the other hand, the GREEN-RIPE protein, which might play an important role in regulating the ethylene receptor signal output (Barry and Giovannoni, 2006), was found in the Golgi (Figure 3.42), which is also part of the endomembrane system. Although several ethylene signalling components have been found in the ER, it remains largely unknown how the ethylene signal is transmitted to the downstream transcription factors inside the nucleus to cause physiological changes such as fruit ripening and leaf senescence. The ER happens to be one of the intracellular Ca^{2+} storage sites together with chloroplast and vacuole. In addition, it has long been hypothesized that Ca^{2+} would be a secondary messenger in the ethylene signalling pathway (Raz and Fluhr, 1992). More importantly, Zhao and his colleague have recently shown a transient Ca^{2+} spike induced by ethylene in tobacco protoplasts (Zhao *et al.*, 2007). Therefore, it would be very interesting to establish whether or not ethylene is controlling the ion channels in the ER membrane and uses Ca^{2+} as a secondary messenger to regulate gene expression inside the nucleus. This could be achieved by using the large collection of the *Arabidopsis* ethylene insensitive mutants. For example, if the ethylene induced Ca^{2+} influx could be blocked by mutation in the ER protein EIN2, but not by the nucleus transcription factor EIN3, it would be reasonable to suggest that Ca^{2+} is the “missing” secondary messenger of ethylene.

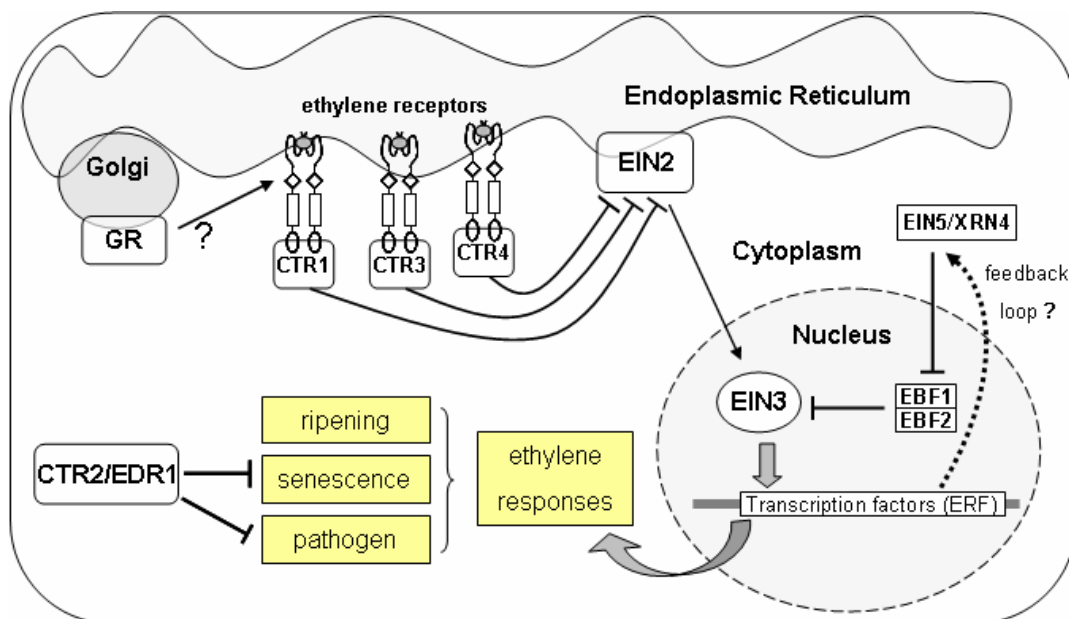

Figure 4.3: Proposed model of ethylene signalling in a tomato cell

The image illustrates a diagram of proposed ethylene action in a tomato cell. The ER membrane-bound ethylene receptors associate with the downstream Ser/Thr kinase CTR1, CTR3 and CTR4. The GREEN-RIPE protein is located in the Golgi and affects the ethylene sensitivity of the receptors. The ER membrane protein EIN2 acts genetically downstream of CTRs and negatively regulates an ethylene response transcription factor EIN3. The EBF1 and 2 are E3 ubiquitin ligase targeting EIN3 for degradation. EBF mRNA is degraded by EIN5 possibly as a feedback loop of ethylene responses. The cytosolic LeCTR2 might be a homologue of the *Arabidopsis* EDR1 and negatively regulates the defence response and ethylene-induced leaf senescence.

References

- Adam Z., Zaltsman A., Sinvany-Villalobo G. and Sakamoto W.** (2004) FtsH protease in chloroplasts and cyanobacteria. *Physiologia Plantarum*. 123:386-390.
- Adams-Phillips L., Barry C., Kannanz P., Leclercq J., Bouzayen M. and Giovannoni J.J.** (2004) Evidence that CTR1-mediated ethylene signal transduction in tomato is encoded by a multigene family whose members display distinct regulatory features. *Plant Molecular Biology*. 54:384-404.
- Alexander L. and Grierson D.** (2002) Ethylene biosynthesis and action in tomato: a model for climacteric fruit ripening. *Journal of Experimental Botany*. 53: 2039–2055.
- Alonso J.M., Hirayama T., Roman G., Nourizadeh S. and Ecker J.R.** (1999) EIN2, a bifunctional transducer of ethylene and stress responses in *Arabidopsis*. *Science*. 284:2148–2152.
- Aravind L. and Ponting C.P.** (1997) The GAF domain: an evolutionary link between diverse phototransducing proteins. *Trends in Biochemical Sciences*. 22:458-459.
- Barry C.S. and Giovannoni J.J.** (2006) Ripening in the tomato *green-ripe* mutant is inhibited by ectopic expression of a protein that disrupts ethylene signalling. *Proceedings of the National Academy of Sciences, USA*. 103:7923-7928.
- Bartel P.L. and Fields S.** (1997) *The yeast two-hybrid system*. Oxford University Press.
- Beyer A.** (1997) Sequence analysis of the AAA protein family. *Protein Science*. 6:2043-2058.
- Bhalerao R.P., Salchert K., Bako L., Okresz L., Szabados L., Muranaka T., Machida Y., Schell J. and Koncz C.** (1999) Regulatory interaction of PRL1 WD protein with *Arabidopsis* SNF1-like protein kinases. *Proceedings of the National Academy of Sciences, USA*. 96:4746-4748.
- Binder B.M., Mortimore L.A., Stepanova A.N., Ecker J.R. and Bleecker A.B.** (2004) Short-term growth responses to ethylene in *Arabidopsis* seedlings are EIN3/EIL1 independent. *Plant physiology*, 136:2921-2927.
- Bleecker A.B., Estelle M.A., Somerville C. and Kende H.** (1988) Insensitivity to ethylene conferred by a dominant mutation in *Arabidopsis thaliana*. *Science*. 241:1086-1089.
- Bowles D., Isayenkova J., Lim E.K. and Poppenberger B.** (2005)

Glycosyltransferases: managers of small molecules. *Current Opinion in Plant Biology*. 8:254-263.

Cancel J.D. and Larsen P.B. (2002) Loss-of-function mutants in the ethylene receptor *ETR1* cause enhanced sensitivity and exaggerated response to ethylene in *Arabidopsis*. *Plant Physiology*. 129:1557-1567.

Chang C., Kwok S.F., Bleecker A.B. and Meyerowitz E.M. (1993) *Arabidopsis* ethylene response gene *ETR1*: Similarity of product to two-component regulators. *Science*. 262:539-544.

Chao Q., Rothenberg M., Solano R., Roman G., Terzaghi W. and Ecker J.R. (1997). Activation of the ethylene gas response pathway in *Arabidopsis* by the nuclear protein ETHYLENE-INSENSITIVE3 and related proteins. *Cell*. 89:1133-44.

Charbonneau H., Prusti R.K., LeTrong H., Sonnenburg W.K., Mullaney P.J., Walsh K.A. and Beavo J.A. (1990) Identification of a noncatalytic cGMP-binding domain conserved in both the cGMP-stimulated and photoreceptor cyclic nucleotide phosphodiesterase. *Proceedings of the National Academy of Sciences, USA*. 87:288-292.

Chen Y.F., Randelett M.D., Findell J.L. and Schaller G.E. (2002) Localization of the ethylene receptor ETR1 to the Endoplasmic Reticulum of *Arabidopsis*. *Journal of Biological Chemistry*. 277:19861-19866.

Chiwocha S.D.S., Cutler A.J., Abrams S.R., Ambrose S.J., Yang J., Ross A.R.S. and Kermod A.R. (2005) The *etr1-2* mutation in *Arabidopsis thaliana* affects the abscisic acid, auxin, cytokinin and gibberellin metabolic pathways during maintenance of seed dormancy, moist-chilling and germination. *The plant Journal*. 42:35-48.

Clark K.L., Larsen P.B., Wang X. and Chang C. (1998) Association of the *Arabidopsis* CTR1 Raf-like kinase with the ETR1 and ERS1 ethylene receptors. *Proceedings of the National Academy of Sciences, USA*. 95:5401-5406.

Clough S.J. and Bent A.F. (1998) Floral dip: a simplified method for *Agrobacterium*-mediated transformation of *Arabidopsis thaliana*. *Plant Journal*. 16:735-743.

Criekinge W.V. and Beyaert R. (1999) Yeast two-hybrid: state of the art. *Biological Procedures Online*. 2:1-38.

Ecker J.R. (2004) Reentry of the ethylene MPK6 module. *Plant Cell*, 16:3169-3173.

Fray R.G. and Grierson D. (1993) Molecular genetics of tomato fruit ripening. *Trends*

in Genetics. 9: 438–443.

Frye C.A. and Innes R.W. (1998) An *Arabidopsis* mutant with enhanced resistance to powdery mildew. *The Plant Cell*. 10:947-956.

Frye C.A., Tang D.Z. and Innes R.W. (2001) Negative regulation of defense responses in plants by a conserved MAPKK kinase. *Proceedings of the National Academy of Sciences, USA*. 98:373-378.

Gamble R.L. and Schaller G.E. (2002) Mutational analysis of the ethylene receptor ETR1. Role of the histidine kinase domain in dominant ethylene insensitivity. *Plant Physiology*. 128:1428-1438.

Gao Z., Chen Y-F., Randlett M.D., Zhao X-C., Findell J.L. Kiber J.J. and Schaller G.E. (2003) Localization of the Raf-like kinase CTR1 to the endoplasmic reticulum of *Arabidopsis* through participation in ethylene receptor signalling complexes. *The Journal of Biological Chemistry*. 278:34725-34732.

Gibson S.I. (2004) Sugar and phytohormones response pathways: navigating a signalling network. *Journal of Experimental Botany*. 55:253-264.

Gibson S.I., Laby R.J and Kim D. (2001) The sugar-insensitive1 (*sis1*) mutant of *Arabidopsis* is allelic to *ctr1*. *Biochemical and Biophysical Research Communications*. 280:196-203.

Gray J., Picton S., Shabbeer J., Schuch W., Grierson D. (1992) Molecular biology of fruit ripening and its manipulation with antisense genes. *Plant Molecular Biology*. 19: 69–87.

Grierson D. and Kader A.A. (1986) Fruit ripening and quality. *The Tomato Crop*, Chapman & Hall, London, 241-280.

Grierson D., Tucker G.A. and Robertson N.G. (1981) The molecular biology of ripening. Recent advances in the biochemistry of fruit and vegetables. Academic Press, London, 147-158.

Grierson D., Tucker G.A., Keen J., Ray J., Bird C.R. and Schuch W. (1986) Sequencing and identification of a cDNA clone from tomato polygalacturonase. *Nucleic Acid Research*. 14:8595-8603.

Guo H. and Ecker J.R. (2003) Plant responses to ethylene gas are mediated by SCF(EBF1/EBF2)-dependent proteolysis of EIN3 transcription factor. *Cell*. 115:667-677.

- Hackett R.M., Ho, C.W., Lin ZF. Foote H.C.C., Fray R.G. and Grierson D.** (2000) Antisense inhibition of the *Nr* gene restores normal ripening to the tomato *Never-ripe* mutant, consistent with the ethylene receptor-inhibition model. *Plant Physiology*. 124:1079-1085.
- Hall A.E. and Bleeker A.B.** (2003) Analysis of combinatorial loss-of-function mutants in the *Arabidopsis* ethylene receptors reveals that the *ers1/etr1* double mutant has severe developmental defects that are EIN2 dependent. *The Plant Cell*. 15:2032-2041.
- Hall A.E., Chen Q.G., Findell J.L., Schaller G.E. and Bleeker A.B.** (1999) The relationship between ethylene binding and dominant insensitivity conferred by mutant forms of the ETR1 ethylene receptor. *Plant Physiology*. 121:291-299.
- Hamilton A.J., Bouzayen M. and Grierson D.** (1991) Identification of a tomato gene for the ethylene-forming enzyme by expression in yeast. *Proceedings of the National Academy of Sciences, USA*. 88:7434-7437.
- Hamilton A.J., Fray R.G., Grierson D.** (1995) Sense and antisense inactivation of fruit ripening genes in tomato. *Current Topics in Microbiology and Immunology*. 197:77-89.
- Hanton S.L. and Brandizzi F.** (2006) Fluorescent Proteins as markers in the plant secretory pathway. *Microscopy Research and Technique*. 69:152-159.
- Haseloff J., Siemering, K.R., Prasher, D.C. and Hodge S.** (1997) Removal of a cryptic intron and subcellular localization of green fluorescent protein are required to mark transgenic *Arabidopsis* plants brightly. *Proceedings of the National Academy of Sciences USA*. 94:2122-2127.
- Heim R., Prasher D.C. and Tsien R.Y.** (1994) Wavelength mutations and posttranslational autoxidation of green fluorescent protein. *Proceedings of the National Academy of Sciences USA*. 91:12501-12504.
- Hirayama T., Kieber J.J., Hirayama N., Kogan M., Guzman P., Nourizadeh S., Alonso J.M., Dailey W.P., Dancis A. and Ecker J.R.** (1999) RESPONSIVE-TO-ANTAGONIST1, a Menkes/Wilson disease-related copper transporter, is required for ethylene signaling in *Arabidopsis*. *Cell*. 97:383-393.
- Holdsworth M.J., Bird C.R., Ray J., Schuch W. and Grierson D.** (1987) Structure and expression of an ethylene-related mRNA from tomato. *Nucleic Acids Research*. 15:731-739.
- Hou B.K., Lim E.K., Higgins G.S. and Bowles D.** (2004) N-glycosylation of cytokinins by glycosyltransferases of *Arabidopsis thaliana*. *Journal of Biological Chemistry*. 279:47822-47832.

- Hu C-D. and Kerppola T.K.** (2003) Simultaneous visualization of multiple protein interactions in living cells using multicolour fluorescence complementation analysis. *Nature Biotechnology*. 21:539-545.
- Hu C-D., Chinenov Y. and Kerppola T.K.** (2002) Visualization of interactions among bZIP and Rel proteins in living cells using biomolecular fluorescence complementation. *Molecular Cell*. 9:789-798.
- Hua J. and Meyerowitz E.M.** (1998) Ethylene responses are negatively regulated by a receptor gene family in *Arabidopsis thaliana*. *The Plant Cell*. 94:261-271.
- Hua J., Chang C., Sun Q., Meyerowitz E.M.** (1995) Ethylene sensitivity conferred by *Arabidopsis* ERS gene. *Science*. 269:1712-1714.
- Huang, Y.F., Li, H., Hutchison, C.E., Laskey, J. and Kieber, J.J.** (2003) Biochemical and functional analysis of CTR1, a protein kinase that negatively regulates ethylene signaling in *Arabidopsis*. *The Plant Journal*. 33:221-233.
- Isaacson T., Ronen G., Zamir D. and Hirschberg J.** (2002) Cloning of *TANGERINE* from tomato reveals a carotenoid isomerase essential for the production of beta-carotene and xanthophylls in plants. *The Plant Cell*. 14:333-342.
- Jones P., Messner B., Nakajima J., Schaffner A.R. and Saito K.** (2003) UGT73C6 and UGT78D1, glycosyltransferases involved in flavonol glycoside biosynthesis in *Arabidopsis thaliana*. *Journal of Biological Chemistry*. 278:43910-43918.
- Karimi M., Inze D. and Depicker A.** (2002) Gateway vectors for *Agrobacterium*-mediated plant transformation. *Trends in Plant Sciences*. 7:193-195.
- Keegan A.B., Kelly K.M. and Staden J.V.** (1988) Ethylene involvement in dormancy release of *Ricinus dendron rautanenii* seeds. *Annals of Botany*, 63:229-234.
- Kieber J.J., Rothenburg M., Roman G., Feldmann K.A. and Ecker J.R.** (1993) *CTR1*, a negative regulator of the ethylene response pathway in *Arabidopsis* encodes a member of the Raf family of protein kinases. *Cell*. 72:427-441.
- Klee H.J.** (2002) Control of ethylene-mediated processes in tomato at the level of receptors. *Journal of Experimental Botany*. 53:2057-2063.
- Klee H.J.** (2004) Ethylene signal transduction: moving beyond *Arabidopsis*. *Plant Physiology*. 135:660-667.
- Lashbrook C., Tieman D. and Klee H.J.** (1998) Differential regulation of the tomato *ETR* gene family throughout plant development. *Plant Journal*. 15:243-252.

- Leclercq J., Adams-Philips L.C., Zegzouti H., Jones B., Latche A., Giovannoni J.J., Pech J.-C. and Bouzayen M.** (2002) *LeCTR1*, a tomato *CTR1*-like gene, demonstrates ethylene signalling ability in *Arabidopsis* and novel expression patterns in tomato. *Plant Physiology*. 130:1132-1142.
- Lin Z., Hackett R.M., Payton S. and Grierson D.** (1998) A tomato sequence (AJ005077) encoding an *Arabidopsis CTR1* homologue. *Plant Physiology*. 117:1125.
- Lin Z., Li H., Kim S., Alexander L. and Grierson D.** (2003) Identification of proteins interacting with TCTR2, an ethylene signalling component in tomato. *Biology and Biotechnology of the Plant Hormone Ethylene III*. IOS Press, Amsterdam, Netherlands.
- Liu Y. and Zhang S.** (2004) Phosphorylation of 1-aminocyclopropane-1-carboxylic acid synthase by MPK6, a stress-responsive mitogen-activated protein kinase, induces ethylene biosynthesis in *Arabidopsis*. *The Plant Cell*. 16:3386-3399.
- Liu Y., Schiff M. and Dinesh-Kumar SP.** (2002) Virus-induced gene silencing in tomato. *The plant Journal*. 31:778-786.
- Ma B., Cui M.L., Sun H.J., Takada K., Mori H., Kamada H. and Ezura H.** (2006) Subcellular Localization and Membrane Topology of the Melon Ethylene Receptor CmERS1. *Plant Physiology*. 141:587-597.
- Mousatche P. and Klee H.J.** (2004) Autophosphorylation of the *Arabidopsis* ethylene receptor multigene family. *Journal of Biological Chemistry*. 279: 48734-48741.
- Nagai T., Ibata K., Park E.S., Kubota M., Mikoshiba K. and Miyawaki A.** (2002) A variant of yellow fluorescent protein with fast and efficient maturation for cell-biological applications. *Nature Biotechnology*. 20:87-90.
- Nemeth K., Salchert K., Putnoky P., Bhalerao R., Koncz-Kalman Z., Stankovic-Stangeland B., Bako L., Mathur J., Okresz L., Stabel S., Geigenberger P., Stitt M., Redei GP., Schell J. and Koncz C.** (1998) Pleiotropic control of glucose and hormone responses by PRL1, a nuclear WD protein, in *Arabidopsis*, *Genes and Development*. 12:3059-3073.
- Nguyen A.W. and Daugherty P.** (2005) Evolutionary optimization of fluorescent proteins for intracellular FRET. *Nature Biotechnology*. 23:355-360.
- Nixon P.J., Barker M., Boehm M., Vries R. and Komenda J.** (2004) FtSH-mediated repair of the photosystem II complex in response to light stress. *Journal of Experimental Botany*. 56:357-363.
- O'Neil M.J.** (2006) *The Merck Index*, 14th Ed. Whitehouse Station, New York.

- Olmedo G., Guo H., Gregory B.D., Nourizadeh S.D., Aguilar-Henonin L., Li H., An F., Guzman F., and Ecker J.R.** (2006) ETHYLENE-INSENSITIVE5 encodes a 5'->3' exonuclease required for regulation of the EIN3-targeting F-box proteins EBF1/2. *Proceedings of the National Academy of Sciences, USA.* 103:13286-13293.
- Ouaked F., Rozhon W., Lecourieux D. and Hirt H.** (2003) A MAPK pathway mediates ethylene signalling in plants. *The EMBO Journal.* 22:1282-1288.
- Pietrzak M., D.Shillito R., Hohn, T. and Potrykus I.** (1986) Expression in plant of two bacterial antibiotic resistance genes after protoplast transformation with a new plant expression vector. *Nucleic Acid Research.* 14:5857-5868.
- Poppenberger B., Berthiller B., Lucyshyn D., Sieberer T., Schuhmacher R., Krska R., Kuchler K., Glössl J., Luschnig C. and Adam G.** (2003) Detoxification of the *Fusarium* Mycotoxin Deoxynivalenol by a UDP-glucosyltransferase from *Arabidopsis thaliana*. *Journal of Biological Chemistry.* 278:47905-47914.
- Poppenberger B., Berthiller F., Bachmann H., Lucyshyn D., Peterbauer C., Mitterbauer R., Schuhmacher R., Krska R., Glossl J. and Adam G.** (2006) Heterologous Expression of *Arabidopsis* UDP-Glucosyltransferases in *Saccharomyces cerevisiae* for Production of Zearalenone-4-O-Glucoside. *Applied and Environmental Microbiology.* 72: 4404 - 4410.
- Poppenberger B., Fujioka S., Soeno K., George G.L., Vaistij F.E., Hiranuma S., Seto H., Takatsuto S., Adam G., Yoshida S. and Bowles D.** (2005) The UGT73C5 of *Arabidopsis thaliana* glucosylates brassinosteroids. *Proceedings of the National Academy of Sciences USA.* 102:15253-15258.
- Potuschak T., Vansiri A., Binder B.M., Lechner E., Vierstra R.D. and Genschika P.** (2006) The exonuclease XRN4 is a component of the ethylene response pathway in *Arabidopsis*. *The Plant Cell.* 18:3047-3057.
- Qu X. and Schaller G.E.** (2004) Requirement of the histidine kinase domain for signal transduction by the ethylene receptor ETR1. *Plant Physiology.* 136:2961-2970.
- Qu X., Hall B.P., Gao Z. and Schaller G.E.** (2007) A strong constitutive ethylene-response phenotype conferred on *Arabidopsis* plants containing a null mutation in the ethylene receptor ETR1 and ERS1. *BMC Plant Biology.* 7:3.
- Radhamony R.N. and Theg S.M.** (2006) Evidence for an ER to Golgi to chloroplast protein transport pathway. *Trends in Cell Biology.* 16:385-387.
- Raz V. and Fluhr R.** (1992) Calcium requirement for ethylene-dependent response. *The Plant Cell.* 4:1123-1130.

- Resnick J.S., Wen C-K., Shockey J.A. and Chang C.** (2006) Reversion-to-ethylene sensitivity1, a conserved gene that regulates ethylene receptor function in *Arabidopsis*. Proceedings of the National Academy of Sciences, USA. 103:7917-7922.
- Rizzo M.A., Springer G.H., Granada B. and Piston D.W.** (2004) An improved cyan fluorescent protein variant useful for FRET. Nature Biotechnology, 22:445-449.
- Rodriguez F.I., Esch J.J., Hall A.E., Binder B.M., Schaller G.E. and Bleeker A.B.** (1999) A copper cofactor for the ethylene receptor ETR1 from *Arabidopsis*. Science. 283:996-998.
- Rolland F., Moore B. and Sheen J.** (2002) Sugar sensing and signalling in plants. The Plant Cell. 14:185-205.
- Sakai H., Hua J., Chen Q.G., Chang C., Medrano L.J., Bleeker A.B., and Meyerowitz E.M.** (1998) *ETR2* is an *ETR1*-like gene involved in ethylene signalling in *Arabidopsis*. Proceedings of the National Academy of Sciences, USA. 95:5812-1517.
- Sakamoto W., Tamura T., Hanba-Tomita Y. and Murata M.** (2002) The *VAR1* locus of *Arabidopsis* encodes a chloroplastic FtsH and is responsible for leaf variegation in the mutant alleles. Genes Cells. 7:769-780.
- Sakamoto W., Zaltsman A., Adam Z. and Takahashi Y.** (2003) Coordinated regulation and complex formation of YELLOW VARIEGATED1 and YELLOW VARIEGATED2, chloroplastic FtsH metallo-proteases involved in the repair cycle of photosystem II in *Arabidopsis* thylakoid membranes. The Plant Cell. 15: 2843-2855.
- Sash J.** (2003) The salicylic acid loop in plant defence. Current Opinion in Plant Biology. 6:365-371.
- Schaller G.E. and Bleeker A.B.** (1995) Ethylene-binding sites generated in yeast expressing the *Arabidopsis ETR1* gene. Science. 270:1809-1811.
- Schaller G.E. and Kieber J.J.** (2002) Ethylene. The *Arabidopsis* book. American Society of Plant Biologists, Rockville, MD.
- Schaller G.E., Mathews D.E., Gribskov M. and Walker J.C.** (2002) Two-component signalling elements and histidyl-aspartyl phosphorelays. The *Arabidopsis* book. American Society of Plant Biologists, Rockville, MD.
- Seo S., Okamoto M., Iwai T., Iwano M., Fukui K., Isogai A., Nakajima N. and Ohashi Y.** (2000) Reduced levels of chloroplast FtsH protein in tobacco mosaic virus-infected tobacco leaves accelerate the hypersensitive reaction. The Plant Cell. 12:917-932.

- Serebriiskii I., Estojak J., Berman M. and Golemis E.** (2000) Approaches to detecting false positive in yeast two-hybrid systems. *Biotechniques*. 28:328-336.
- Seymour G.B., Taylor J.E. and Tucker G.A.** (1993) *Biochemistry of fruit ripening*. 1st Ed., Chapman & Hall, London, UK.
- Shaner N., Steinbach P. and Tsien R.Y.** (2005) A guide to choosing fluorescent protein. *Nature Method*. 12:905-909.
- Shimomura O., Johnson F.H. and Saiga Y.** (1962) Extraction, purification and properties of aequorin, a bioluminescent protein from the luminous hydromedusa, *Aequorea*. *Journal of Cellular Comparative Physiology*. 59:223-239.
- Shyu Y., Liu H., Deng X. and Hu C-D.** (2006) Identification of new fluorescent fragments for BiFC analysis under physiological conditions. *BioTechniques*. 40:61-66.
- Solano R., Stepanova A., Chao Q. and Ecker J.R.** (1998) Nuclear events in ethylene signaling: a transcriptional cascade mediated by ETHYLENE INSENSITIVE3 and ETHYLENE RESPONSE FACTOR1. *Genes and Development*. 12:3703–3714.
- Stephen D.J. and Banting G.** (2000) The use of yeast two-hybrid screens in studies of protein:protein interactions involved in trafficking. *Traffic*. 1:763-768.
- Takeshi U., Kazuko Y.S. and Kazuo S.** (2000) Two-component systems in plant signal transduction. *Trends in Plant Sciences*. 5:67-74.
- Tang D.Z. and Innes R.W.** (2002) Overexpression of a kinase-deficient form of the EDR1 gene enhances powdery mildew resistance and ethylene-induced senescence in *Arabidopsis*. *The Plant Journal*. 32:975-983.
- Tang D.Z., Christiansen K.M. and Innes R.W.** (2005) Regulation of plant disease resistance, stress responses, cell death and ethylene signalling in *Arabidopsis* by the EDR1 protein kinase. *Plant Physiology*. 138:1018-1026.
- Tieman D. and Klee H.J.** (1999) Differential expression of two novel members of the tomato ethylene-receptor family. *Plant Physiology*. 121:1093-1102.
- Vidalain P., Boxem M., Ge H., Li S. and Vidal M.** (2003) Increasing specificity in hi-throughput yeast two-hybrid experiments. *Methods*. 32:363-370.
- Wang K.L., Yoshida H., Lurin C. and Ecker J.R.** (2004) Regulation of ethylene gas biosynthesis by the *Arabidopsis* ETO1 protein. *Nature*. 428:945-950.
- Wang W., Hall A.E., O'Malley R. and Blecker A.B.** (2003) Canonical histidine kinase

activity of the transmitter domain of the ETR1 ethylene receptor from *Arabidopsis* is not required for signal transmission. Proceedings of the National Academy of Sciences, USA. 100:352-357.

Wang, K.L., Li. H. and Ecker, J.R. (2002) Ethylene biosynthesis and signalling networks. *The Plant Cell*, 14:131-151.

Wilkinson J.Q., Lanahan M.B., Yen H-C., Giovannoni J.J. and Klee H.J. (1995) An ethylene-inducible component of signal transduction encoded by *Never-ripe*. *Science*. 270:1807–1809.

Woeste K.E and Kieber J.J. (2000) A strong loss-of-function mutation in *RAN1* results in constitutive activation of the ethylene response pathway as well as a rosette-lethal phenotype. *The Plant Cell*. 12:443-455.

Xie F., Liu Q. and Wen C.K. (2006) Receptor signal output mediated by the ETR1 N-terminus is primarily subfamily I receptor dependent. *Plant Physiology*. 142:492-508.

Yang S.F. and Hoffman N.E. (1984) Ethylene biosynthesis and its regulation in higher plants. *Annual Reviews in Plant Physiology*. 35:155-189.

Yen HC., Lee S., Tanksley S.D., Lanhan M.B., Klee H.J. and Giovannoni J.J. (1995) The tomato *Never-ripe* locus regulates ethylene-inducible gene expression and is linked to a homologue of the *Arabidopsis ETR1* gene. *Plant Physiology*. 107:1343-1353.

Yip W-K and Yang S.F. (1988) Cyanide metabolism in relation to ethylene production in plant tissues. *Plant Physiology*. 88:473-476.

Yu F., Park S. and Rodermeil S.R. (2004) The *Arabidopsis* FtsH metalloprotease gene family: interchangeability of subunits in chloroplast oligomeric complexes. *The Plant Journal*. 37:864-876.

Zhao M-G, Tian Q-Y. and Zhang W-Z. (2007) Ethylene activates a plasma membrane Ca^{2+} -permeable channel in tobacco suspension cells. *New Phytologist*. 174:507–515.

Zhou, D., Kalaitzis, P. Matto, AK. and Tucker, ML. (1996) The mRNA of an *ETR1* homologue in tomato is constitutively expressed in vegetative and reproductive tissues. *Plant Molecular Biology*. 30:1331-1338.

APPENDIX

Sequence of IntCR22

LOCUS IntCR22 1473 bp DNA linear
 KEYWORDS Interacting with CTR2 clone 22
 ORGANISM *Solanum lycopersicum* (*Lycopersicon esculentum*)

```

1 atgggtgttc ttactataga gccacat ttt gtgttg tttc ctttcatggc acaaggccat
61 acaatcccta tgattgatat tgcgcgatta ctagcacaac gcgagttat tatcacaatc
121 gttacaacac atttgaacgc gaatagattc aagaaagtca ttgatcgcgc tatagaatca
181 ggactgaaaa ttcaggtggt tcatctctac tttccaagct tagaggctgg actgcctgaa
241 ggatgtgaaa atttcgacat gcttccatcg atggatttgg ggctgaaatt cttcgatgct
301 acgaaagac ttcagcccca agtggaaaga atgttgcgag aatgaaacc ttcaccaagt
361 tgtataatat ctgatatgtg tttcccatgg acaactaatg ttgcacaaaa gttcaacatt
421 cctagaattg ttttccatgg aatgggttgc ttttcttgt tatgtttaca taatttgaaa
481 gattgggaag ggtagaaaa gatcgagtct gatacagagt attttcgagt gcctggattg
541 ttcgacaaga ttgaactaac caaaaatcag cttggaaatg ctgccaggcc gagaaatgaa
601 gaggggcag taatgagtga aaaaatgaag aaagcggagg aggaagctta tggaatggtg
661 gtgaatacct ttgaggattt ggaaaaagaa tacatcgagg gtttaatgaa tgcgaaaaac
721 aagaaaat tggaccattg ccctgttca ctctgtaaca aagaaaaaca ggacaaagct
781 gaaagagga acgaggctgc aattgatgaa cacaagtgtc taaactggct tgattcgtgg
841 gaacaaaact ctgtactctt tgtatgtctc gggagcctat cgcgccttc cacgtctcag
901 atggttgagc tagggcttgg gttagaatca tcgagacgac cttttatttg ggttgttaga
961 cacatgtcag atgagttcaa gaattggcta gttgaagaag attttgagga aagagttaaa
1021 gggcaaggac tattaatccg cggttgggcg ccacaagtac tactcttgtc acatccttca
1081 ataggtgcgt tcttgactca ctgtggatgg aattcgagcc tggaaaggat aaccgctggc
1141 gtggccatga tcacttgcc aatgtttctc gagcagtttt gtaatgagag gttaatagtg
1201 gatgtactca agacaggagt gaggtcaggc atagagaggc aagtgatggt tggagaagaa
1261 gaaaaattgg gaacacaagt aagcaaagat gacattaaga aggtgattga acaagtgatg
1321 gatgaagaaa tggaaaggta aatgagaaga aaaagagcaa aagaattagg agaaaaggca
1381 aagagggcta tggaggaaga gggttcatct catttcaact tgacacaatt gattcaagat
1441 gtgacagagc aagcaaaaat tttaaaacct atg

```

//

Sequence of IntCR242

LOCUS IntCR242 1389 bp DNA linear
 SOURCE
 ORGANISM *Solanum lycopersicum* (*Lycopersicon esculentum*)

```

1 atggcttctt tgtctataga catagccacc acctttatgg gactggccaa gcgtcagacc
61 ccacagttct atggctcttcg tacagcagtg ttcccaactt tgtggaaaac aagcaaatgt
121 cagaggttca gtttatccac tagttcctct tcgagaatta gtgttgcaat caatacttct
181 tcaaaaccaa acagattctc tcgcggattt actgtttctg ctacatctac ttccgccccg
241 caaagcgagg actctgatat cttaaccaag attcctcaag ataatcgaat tccagctacc
301 attatcactg gtttcttggg ttctgggaaa actaccttat taaatcacat attgactgcg
361 gatcatggca agcgcattgc tgttatagag aatgagtatg gtgaagtgga tattgatggt
421 tctttggttg ctgcaaaaac tgctggggcg gaggagatta tgatgcttaa caatgggtgt
481 ctctgttgca ctgtgagggg tgatctagta agaatgatcg cagagttggt cagtagaaaag
541 aaagggaaat ttgaccatat tgtcatagag actacaggat tggcaaatcc tgcaccaatt
601 attcaaacctt tctacgcgga ggatcaggtt ttcaatgatg ttaagtggga tgggtgtggt
661 aactgggttg attctaaaca tgttggtttt cacttgatg agactaagcc aaaaggtgtc
721 gtcaatgaag cagttgagca aatagcttat gctgaccgta ttataattaa caagactgat
781 cttgttggtg attctgaagt ttcttctttg attcagcgaa ttaagaacat aaataagatg
841 gctcatttga agaggacaca gtttgaaaa gtcgatttgg actatgtcct agggattgga
901 ggctttgatt tggaaagaat tgagagtctg gttggtgctg aaggttctaa ggaggaccat
961 actggccatg atcatgatca tgatcatgat caccaccacc atcatgacca cgaccatgat
1021 catgaacatg aacatgaaca tgatcacaag catgagcatc atgatcatca ccattctcac
1081 gatcatactc atgaccctgg tgtttcttct gtcagcatag tttgtgaagg gaccttggat
1141 cttgagaagg ctaatatgtg gttgggaacg ttgctgatgg aacgaagcga tgacatatat
1201 cggatgaagg gtctttttatc tgttgagga atggatgaga gatttgtctt tcagggagtc
1261 catgacatat ttcaaggttc tccagatagg ccatggaagt cggacgaact aagaacaaac
1321 aagatagtgt ttatagggaa gaacttagat gctaaggaat tagaggaggg cttcaaagcc
1381 tgtttaaca

```

//

Sequence of IntCR266

LOCUS IntCR266 2124 bp DNA linear
 KEYWORDS Interacting with CTR2 clone 266
 ORGANISM *Solanum lycopersicum (Lycopersicon esculentum)*

```

1 atggccaatt ctgtactctc ttccaatttc ttgggttccc aaatctttgt ttctcctccc
61 acacctaaaa cctcaaggta tttccatctt cactccagaa gaaagtatat agttcctcaa
121 tcaattctca gcaaaaaatc caattcagat aatttcaaga atgttccatc taaagctgct
181 atagctgctt tactcttctc ttcaatcacc ccacaagctt ttgctcttga taatacaacc
241 ccagcagcac caccacaagt gattgaagct gaagcaccaa aacctagtgc ctcaactca
301 ttaccctttg ctcaaaatat cattttgaat gctccaaaga ctcaagcgca gcctgcttct
361 gaccttcctg aaggctactca atggaggctac agtgagttct tgaatgctgt gaagaagggg
421 aaagttgaaa gggtagatt tagtaaagac ggaagtacc ttcagcttac agctgtagat
481 gggcgtagag ctaatgtaat tgtgcctaat gacctggatt taatcgatat tttggcgatg
541 aatggtgttg atatatcagt ttctgaaggt gaaggggta atgggttgt tagtgttatt
601 gggaaacttg tgttcctat tattgctttt gctgggttg ttttcctttt caggcggtct
661 cagggcggcc caggtgggcc tggaggactt ggcgggcca tggatttcgg ccggtctaag
721 tccaagtttc aggaggtgcc tgaactgga gtgacttttg ctgatgttgc tgggtctgat
781 caagctaaat tggagttgca ggaagtgtt gatttcttga aaaatcctga taagtatact
841 gcttaggtg ctaagatacc aaaagggtg ctttagttg gtccaccagg tactggaaag
901 acccttttag ctagagcagt agctggtgag gctggtgtgc catttttctc ttgtgcagcg
961 tcagagtttg ttgagttgtt tgtgggtgtg ggagcttcta gagttaggga tttgtttgag
1021 aaggcaaagt cgaaagcacc ttgtattgtg tttattgatg agattgacgc tgtgggaagg
1081 caaagaggtg caggtcttgg aggtggaaat gatgagaggg agcagactat taatcagctt
1141 ttgactgaaa tggatgggtt ctctggaaat tcgggtgtca ttgttttggc tgcaactaac
1201 aggctgatg ttcttgattc tgccttgtt agacctgga ggtttgatcg acaagtgact
1261 gtggatagge ctgatgttgc tggtagagtc aggattcttc aggtgcattc tagaggaaag
1321 gcccttgcca aggatgtgga ctttgataag attgccagga gaacaccagg tttcaccggt
1381 gcagatttgc aaaacttgat gaatgaagca gccatcctt cagctaggcg tgacctaaag
1441 gaaataagta aagatgagat atccgatgct ctagagagga taattgctgg cccggagaag
1501 aaaaatgctg ttgtctcaga tgagaagaag aagctggtag ctatcatga ggctggccat
1561 gccttggttg gtgcacttat gcccgagtat gatcctgtt ccaagatac tataattcct
1621 cgaggccaag ccggtggtct caccttctt gccccagcg aagaaagact tgagtcagcg
1681 ctgtacagca ggagctatct agagaatcaa atggcagttg cacttggttg aagagttgct
1741 gaggaggtta tttttgaca agacaacgta acaactggag catctaacga tttcatgcaa
1801 gtctcacgag tggcaaggca gatggttgag agattaggat tcagcaaaaa gataggccaa
1861 gttgccattg gaggaggtgg tggaaacctg ttctaggcc aacagatgtc aaccagaaa
1921 gactactcca tggcaacagc cgatgtggtc gatgctgaag taaggaatt ggttgaaaag
1981 gcgtacgaaa gagctacaca aatcatcaca actcacatcg acatcctaca caagcttctg
2041 cagctgttga tagagaaaga aactgttgat ggtgaagagt tcatgagcct tttcattgat
2101 ggcaaggctg agctatacat ttct

```

//



Figure: Ethylene-induced leaf senescence phenotype of *edr1* mutant

The *edr1* seeds were a kind gift from Prof. Roger Innes (Department of Biology, Indiana University). The wild-type and *edr1* plants were grown for 6 weeks in a short-day (8 h photoperiod) growth room and treated with 100 ppm ethylene in a sealed plastic container for 72 h. The mutant plant (right) developed more chlorotic leaf (yellowed) than wild-type (left) as reported in Frye *et al.* (2001).

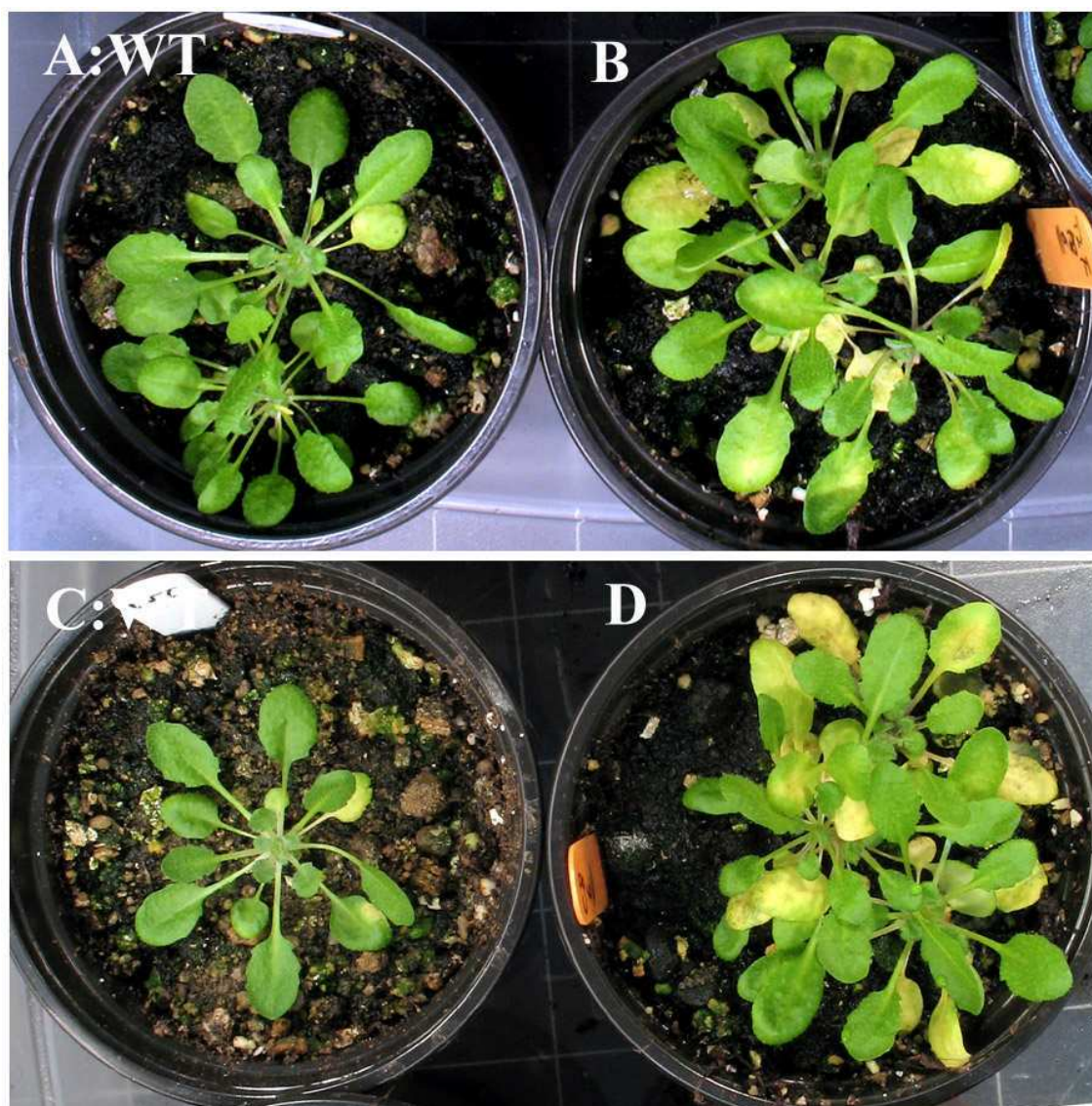

Figure: Ethylene-induced enhanced senescence phenotype of the LeCTR2 transgenic lines

The 6-week-old *Arabidopsis* plants grown in short day condition (8 h photoperiod) were treated with 100 ppm ethylene for three days before the images were taken. The wild-type transformed with the LeCTR2 and LeCTR2-GFP constructs (right) developed more senescent leaves than the untransformed wild-type (left).

(A) and (C): Wild-type

(B) Wild-type transformed with CaMV35Spro::LeCTR2

(D) Wild-type transformed with CaMV35Spro::LeCTR2-GFP

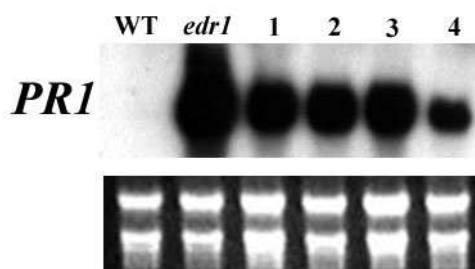

Figure: *PR1* expression in LeCTR2 transgenic lines after ethylene treatment

Northern blot assay was carried out using RNA extracted from the aerial part of the *Arabidopsis* plants treated with 100 pm of ethylene for three days. The mutant *edr1* has the highest *PR1* mRNA level. *PR1* expression in the LeCTR2 transgenic lines (1 to 4) is stronger than that of the wild-type. The UV photograph of the ethidium bromide stained membrane was shown below the autoradiography image.

WT: untransformed wild-type *Arabidopsis* (Col-0)

edr1: *enhanced disease response 1*

Lane 1 and 2: Wild-type transformed with 35S:LeCTR2

Lane 3 and 4: Wild-type transformed with 35S:LeCTR2-GFP

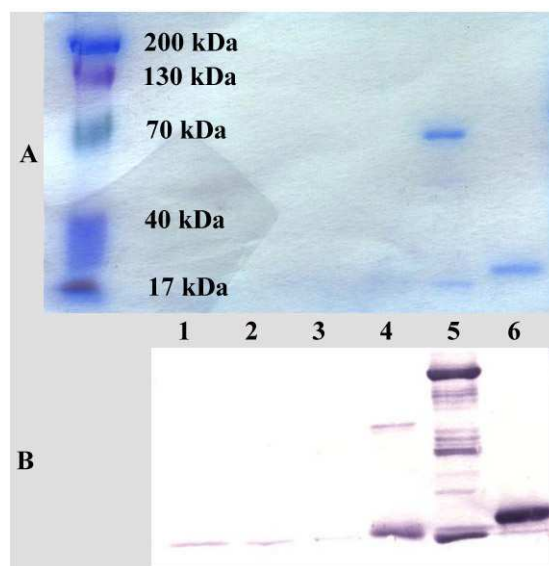

Figure: Purified IntCR22-GST protein

IntCR22 protein fused to GST was purified from yeast using GST affinity resin and western blot was performed as previously described (Section 2.11 and 2.14). This showed that the recombinant IntCR22-GST protein was purified. A) SDS-PAGE gel stained with SimplyBlue; size of the protein markers are indicated. B) Western blot detection of IntCR22-GST using GST antibody.

Lane 1 to 4: Flow through of the washes

Lane 5: Elute, IntCR22 (50 kDa) fused to GST (30 kDa)

Lane 6: Positive control, GST alone (30 kDa)

TABLE1: pDH51-based vectors.

Name	Expression cassette	<i>E. coli</i> and antibiotic
pDH51	35S-MCS-T	DH5 α (Amp)
pDH51-GW	35S-GW-T	DB31 (Amp, Cm)
pDH51-CFP	35S-Cerulean-T	DH5 α (Amp)
pDH51-EGFP	35S-EGFP-T	DH5 α (Amp)
pDH51-YFP	35S-Venus-T	DH5 α (Amp)
pDH51-mRFP1	35S-mRFP1-T	DH5 α (Amp)
pDH51-GW-CFP	35S-GW-Cerulean-T	DB31 (Amp, Cm)
pDH51-GW-GFP	35S-GW-EGFP-T	DB31 (Amp, Cm)
pDH51-GW-YFP	35S-GW-Venus-T	DB31 (Amp, Cm)
pDH51-YFPN	35S-YFPN-T	DH5 α (Amp)
pDH51-YFPC	35S-YFPC-T	DH5 α (Amp)
pDH51-GW-YFPN	35S-GW-YFPN-T	DB31 (Amp, Cm)
pDH51-GW-YFPC	35S-GW-YFPC-T	DB31 (Amp, Cm)

MCS, multiple cloning site; GW, gateway cassette with *attR1* and *attR2* recombination sites; 35S and T, cauliflower mosaic virus 35 S promoter and terminator; Amp, ampicillin resistance; Cm, chloramphenicol resistance; YFPN, N-terminus of Venus (aa 1-154); YFPC, C-terminus of Venus (aa 155-238). Accession number: AM773751-AM773753; AM779183; AM779184.

Table2: Gateway compatible binary vectors with 35S promoter.

Backbone FP Tag	pGreen0029 Kan ⁺	pGreen0229 BAS ⁺	pGreen0179 Hyg ⁺
Cerulean (CFP)	pGKPGWC	pGBPGWC	pGHPGWC
EGFP	pGKPGWG	pGBPGWG	pGHPGWG
Venus (YFP)	pGKPGWY	pGBPGWY	pGHPGWY

All plasmids were propagated in DB31 (kanamycin and chloramphenicol). The *in planta* selection marker gene is based on the pGreen backbone. Kan⁺, kanamycin resistance; BAS⁺, BASTA resistance and Hyg⁺, hygromycin resistance. Accession number: AM884371-AM884379.

Table3: Gateway compatible binary vectors without 35S promoter.

Backbone FP Tag	pGreen0029 Kan ⁺	pGreen0229 BAS ⁺	pGreen0179 Hyg ⁺
Cerulean (CFP)	pGKGWC	pGBGWC	pGHGWC
EGFP	pGKGWG	pGBGWG	pGHGWG
Venus (YFP)	pGKGWY	pGBGWY	pGHGWY

All plasmids were propagated in DB31 (kanamycin and chloramphenicol). The *in planta* selection marker gene is based on the pGreen backbone. Kan⁺, kanamycin resistance; BAS⁺, BASTA resistance and Hyg⁺, hygromycin resistance. Accession number: AM884380-AM884388.