

Petar Andraši¹, Tomislav Radišić¹, Bruno Antulov-Fantulin¹, Doris Novak¹

Methodology for Predicting Sector Capacity in Convective Weather Conditions

¹University of Zagreb, Faculty of Transport and Traffic Sciences, Zagreb, Croatia

Abstract

Convective weather conditions limit airspace capacity and increase the complexity of air traffic. Currently, air navigation service providers calculate sector capacity using air traffic controller workload as reference. The aim of the research is to propose a method for predicting sector capacity in convective weather using air traffic complexity model. In this proposal existing air traffic complexity model should be remodeled to enable finer resolution of complexity results. Also, the model should be upgraded with a new type of indicator showing aircraft-weather interactions. The adopted air traffic complexity model, in combination with the trajectory prediction model and the Weather Ensemble Forecast, should be able to provide a statistical characterisation of sector capacity under impending convective weather conditions.

Keywords: convective weather, air traffic complexity, sector capacity

1. Introduction

One of the main goals of air traffic development in Europe is to increase capacity in order to meet traffic demand while maintaining the necessary levels of safety and efficiency. In the second quarter of 2018, traffic growth of 3.5% was recorded, which is considered a high growth rate [1][2]. Up to 2040, traffic growth of 1.9% per year is forecasted for a regulated growth scenario, while the global growth scenario forecasts growth of 2.7% per year [3].

In order to meet the traffic demand, it is necessary to increase the airspace capacity. Reducing the air traffic complexity is one of the ways of increasing airspace capacity. The first published papers researching air traffic complexity date from 1960s [4] when Davis et al. studied effect of traffic density, traffic mixture and number of terminal areas on air traffic controller. Since the concept of air traffic complexity has not been clearly defined until recent years, most of early research is based on controller workload. It is important to emphasize that air traffic complexity is not the same as air traffic controller workload: rather, these concepts are closely related and directly interdependent. Schmidt [5] approached the problem of complexity from the perspective of controller workload. He created the control difficulty index, which can be calculated as a weighted sum of the expected frequency of occurrence of events that affect controller workload. Each event is given a different weight determined by the time the controller needed to perform the task. Hurst and Rose [6] calculated the correlation between workload and traffic density and proved that only 53% of the variance in reported workload ratings can be explained by traffic density. Stein [7] used Air Traffic

Workload Input Technique (ATWIT), in which controllers reported workload levels during the simulation to determine which of the workload variables mostly affected the workload. Regression analysis proved that out of five starting variables, four variables (localized traffic density, number of handoffs outbound, total amount of traffic, number of handoffs inbound) could explain 67% of variance in ATWIT scores. These variables are also the first defined complexity indicators in literature. In further research, the number of indicators only increased. Kopardekar et al. [8] successfully validated additional 35 indicators, and the same group of researchers demonstrated that only 17 indicators were statistically significant for the calculation of complexity [9]. Masalonis et al. [10] reduced the number of indicators to 12 by referring to probability, predictability, and validity of the given indicator. Klein et al. [11] selected only seven from those 12 indicators by weighting them and using linear regression.

EUROCONTROL experimental center published a detailed complexity study of the Maastricht upper airspace centre [12] in which various complexity indicators were analyzed. Also, in 2006, the EUROCONTROL Performance Review Commission published a final report defining complexity metrics for air navigation service providers benchmarking [13]. In concept of dynamic demand capacity balancing it is suggested that short-term air traffic flow and capacity measures (short-term ATFCM measures) can be used to influence complexity [14]. The proposed short-term ATFCM measures include short notice ground regulations, ground delay, Take Off Not Before, Take Off Not After, re-routing, change in standard instrument departure, flight level reassignment/level capping, and speed regulation. EUROCONTROL continues further exploration of the complexity through

the SESAR PJ.09 project and the first phase will end by the end of October 2019.

So far only Krozel et al. [15] have carried out research on the impact of convective weather on the air traffic complexity. In their research traffic complexity is expressed as a function of velocity variance and traffic density. However, there are many studies that explore the impact of convective weather on flight trajectory, air traffic controller workload, airspace sectorization and air traffic capacity, which is essentially the core of air traffic complexity and complexity reduction measures. Nilim et al. [16] were one of the first to describe the impact of convective weather on the aircraft using Markov decision process and dynamic programming to minimize fuel burn and trip cost or to maximize profit and safety. De-Laura et al. [17] used trajectory data of aircraft flown through convective weather to develop a model for predicting pilot decisions and aircraft trajectories in the three-dimensional space. McNally et al. [18] proposed a weather avoidance system for near-term trajectory-based operations. Considering the shortcomings of previous research, Hentzen et al. [19] proposed a method for modelling the uncertain development of thunderstorms and combined the developed method with an optimal trajectory planning algorithm based on the reach-avoid method. Although all studies on controller workload indicate that with degrading weather, workload increases, Cho et al. [20] were the first to use regression analysis for developing a model which calculates airspace capacity based on controller workload during convective weather. Welch et al. [21] upgraded the controller workload calculation model and repeated the regression process on a new set of data. The result of the regression process is more accurate capacity prediction in all sectors and under all-weather conditions.

Hadley and Sollenberger [22] were the first to combine dynamic sectorization and convective weather by designing by designing a convective weather scenario in their study of the effects of dynamic rectorization on air traffic controllers. Klein et al. [23] demonstrated that dynamic sectorization, together with rerouting can evenly distribute sector occupancy and reduce its peak load. In all previous research dynamic sectorization was applied to two-dimensional space, i.e. the horizontal plane. Klein et al. [24] published a method of dynamic sectorization in three-dimensional space.

Even though Schmidt [5] tried to determine the capacity of airspace through the controller workload, Mitchell et al. [25] were the first to determine the distribution of potential airspace capacity with given probabilistic weather forecast. Krozel et al. [15] published a comprehensive survey assessing airspace capacity in convective weather. In their paper four specific types of traffic flows were considered passing through defined airspace in two operational concepts (free flights and centralized packing systems).

2. Air traffic complexity

Meckiff et al. defined air traffic complexity as a difficulty of monitoring and managing a specific air traffic situation [26]. Complexity is not synonymous with workload, although it has been proven on several occasions that increasing complexity leads to an increase in workload, which in turn limits the capacity of the airspace sector.

Since complexity is a psychological construct, the best estimate of complexity in any traffic situation is the value given by the air traffic controller. By observing traffic data the air traffic controller can evaluate and determine if the traffic situation is complex or not. The main problem with expert-based evaluation is inconsistency between assessors. Different assessors can give different complexity values for the same traffic scenario. This is the main reason why new methods for complexity estimation are developed without human input. Such methods should be validated by comparing them with the experts.

There are three main groups of methods for determining air traffic complexity:

- Expert-based air traffic complexity estimation – as mentioned above, it is a method where experts, in most cases an air traffic controller, gives their estimate of air traffic complexity.
- Indicator-based air traffic complexity estimation – it is method were air traffic complexity is determined using a set of indicators derived from air traffic data.
- Interaction-based air traffic estimation – it is a method where air traffic complexity is described as number of interactions between different aircraft within given airspace cell (this method could also be defined as a very narrow indicator-based air traffic complexity estimation where complexity is estimated using a very small number of indicators).

It further explains only the interaction-based air traffic estimation, as this method is also used by the EUROCONTROL Performance Review Unit (PRU).

3. Interaction-based air traffic complexity model

As already mentioned, interaction-based air traffic estimation is a method that attempts to enumerate all aircraft to aircraft interactions in the defined airspace. The interactions are sorted according to the complexity dimensions that they attempt to describe. This method was proposed in 2006 by EUROCONTROL Performance Review Commission in the final report defining complexity metrics for air navigation service providers benchmarking [13]. The developed method is used by the PRU to calculate the complexity for each air navigation service provider (ANSP) on annual basis and it is one of the indicators for evaluating the effectiveness of ANSPs.

3.1. PRU complexity model

In order to quantify complexity, the EUROCONTROLS working group has defined complexity dimensions that separately describe the characteristics of an air traffic management system, and to the greatest extent affect the complexity experienced by the controller. The complexity dimensions are classified into three groups; traffic characteristics, airspace and external constraints. Each dimension of complexity is described by a set of indicators. The working group extracted four dimensions from the identified complexity dimensions and indicators, each with one indicator. Selected dimensions and indicators have the greatest influence on the route complexity. Complexity dimensions and their indicators are listed in Table 1.

Table 1. Different microreactor types based on specific characteristics

Complexity Dimension	Complexity Indicator
Traffic density	Adjusted density
Traffic in evolution	Potential vertical interactions (VDIF)
Flow structure	Potential horizontal interactions (HDIF)
Traffic mix	Potential speed interactions (SDIF)

Complexity indicators were calculated using a grid of identical 4D cells laid over the desired airspace. As shown in Figure 1, each 4D cell is 20 [nm] wide, 20 [nm] long and 3000 [ft] high, and within the cell there is flight movement data for 60 minutes. The time interval of the data is one day, which means that each day has 24 data sets for each cell (one set for each hour).

Due to the different overlap limits of different airspaces and cell boundaries, a boundary effect occurs where some aircraft are not taken into account in the complexity calculation. To avoid the border effect associated with using the grid, the grid is moved four times horizontally

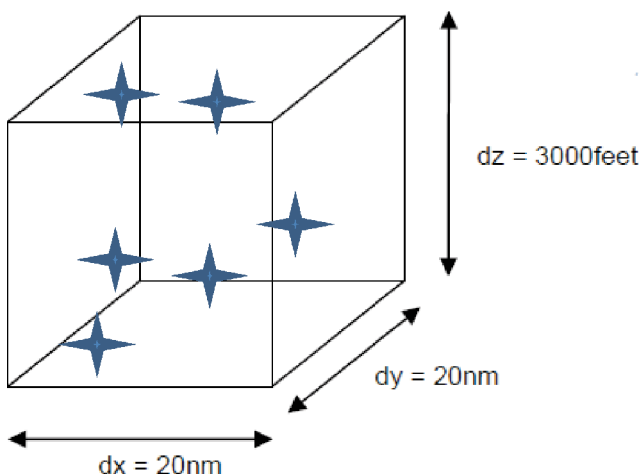

Fig. 1. Cell dimensions

and three times vertically. The horizontal shift is by 10 [nm] and the vertical shift is by 1000 [ft].

Aircraft interaction is the interaction of two aircraft in a single cell. Each pair of planes in a cell forms two interactions. Therefore, when two planes are in a cell, there are two interactions in a cell, but when three planes are in a cell, then there are six interactions in that cell. As indicated in Table 1, there are three types of interaction.

Potential vertical interactions (rVdif) – It is expressed as the duration of potential vertical interactions (in hours) per flight hour. Two aircraft are considered to interact vertically if both are present in the same cell and have different flight phases (one is in climbing and the other is in cruise or any other combination of climbing, descending and cruising). Flight phase of each aircraft is determined when aircraft enters the cell, an aircraft is considered to be in a descending or climbing phase if its rate of change is greater than 500 feet per minute.

Potential horizontal interactions (rHdif) – It is expressed as the duration of potential horizontal interactions (in hours) per flight hour. Two aircraft are considered to interact horizontally if both are present in the same cell and their flight direction differs by more than 20° .

Potential speed interactions (rSdif) – It is expressed as the duration of potential velocity interactions (in hours) per flight hour. Two aircraft are considered to be in speed interaction if both are present in the same cell and have a difference in speeds greater than 35 knots. Cruise speeds for each aircraft were taken from the EUROCONTROL Base of Aircraft Data (BADA) aviation database.

Fourth indicator is *Adjusted density* – the adjusted density is defined as the ratio of sum of aircraft interaction time and sum of aircraft flight time.

Air traffic complexity is the product of adjusted density and the sum of potential vertical, horizontal and speed interactions. The calculation of air traffic complexity is given in equation 1.

$$\text{Complexity} = \text{Adjusted density} * (rVdif + rHdif + rSdif) \quad (1)$$

3.2. Model improvements

The current PRU complexity model was developed for the macroscopic evaluation of various ANSPs. As such it is not precise enough for the microscopic evaluation of different sectors within an airspace. To adopt the current PRU model for microscopic complexity calculations, the following changes must be made:

- Resizing of cell dimensions
- Shortening time window

As the PRU complexity model was developed to calculate air traffic complexity across the European airspace, the cell size (20 x 20 [nm]) was designed to reduce the calculation time. Smaller countries, such as Croatia, cov-

er a relatively small volume of airspace. If the current model were applied to calculate the complexity of sectors in such an airspace, some sectors would have a small number of cells. A small number of cells is not sufficient to locate traffic hotspots within the sector or to calculate the weather effect. To allow a better spatial resolution of the complexity measurement, the horizontal dimensions of cells will be reduced. Further research will investigate the reduction of the cell size to 5 by 5, 7 by 7, 10 by 10 and 15 by 15 [nm].

Convective weather conditions are of short duration. On average, life cycle of cumulonimbus (CB) is 30 minutes. Considering that time frame of PRU complexity model is one hour, a CB cloud could form and dissipate within a time frame. To allow a better temporal resolution, the time frame should be shortened. According to EUROCONTROL [13] in their sensitivity analysis, different time frames had very little effect on the ranking of the centers. The smaller time frames also increased the required computation time. But for microscopic analysis, smaller time frames should allow the localization of peaks in the complexity of air traffic and the possible localization of convective weather.

Even though some indicators are affected by convective weather, e.g. rHdif will increase due to weather avoiding, impact of convective weather on complexity is much higher than indicated by rHdif. To determine the complexity of convective weather conditions, model should be upgraded with another indicator which would relate to aircraft-weather interactions. The weather interaction indicator can be expressed as the ratio of the duration of weather interaction and flight time. Aircraft would be considered for weather interaction if it is in convective weather occupied cell or it is flying in close proximity.

4. Capacity prediction

The calculation of sector capacity is currently based on air traffic controller (ATCO) workload. At sector level, capacity is obtained by measuring or calculating how much time ATCO has actively worked in one hour. Due to safety

concerns the maximum allowable workload of ATCO is 70% of the calculated workload. According to Mogford et al. [27] complexity is a source factor for controller workload. However, complexity and workload are not directly linked. Their relationship is mediated by several other factors, such as equipment quality, individual differences, and controller cognitive strategies. If all mediating factors remain constant, complexity can be used as proxy measure of workload or capacity. Under such conditions, traffic situations of higher complexity will have a higher workload than traffic situations of lower complexity. Sector capacity in convective weather conditions is even harder to calculate due to uncertainties caused by constantly changing weather and mitigating measures taken by pilots. As mentioned in the introduction, DeLaura et al. [17] developed a model that predicts pilots' mitigating actions in convective weather conditions. In their work they proposed a set of weather-based indicators upon which the model determines pilot actions. Since their work is based on historic traffic data in the USA from 2000s it is recommendable to recalculate the indicators in future research. The indicators should be recalculated in the light of advances in aircraft avionics and weather radar, as pilots' actions may not be the same as at the time of data recording. In order to ensure safe separation from other aircraft, the ATCOs must give each pilot permission to avoid action. To allow pilots to avoid action, ATCO must evaluate pilots desired trajectory and confirm that it doesn't create conflict with other aircraft. Such tasks require a lot of time, so that the workload of the ATCOs is significantly increased and the capacity reduced.

Sector capacity in convective weather conditions should be predicted using Ensemble Weather Forecasts (EWF). EWF is a set of forecasts created with multiple weather simulations where each simulation has slight variation of its initial conditions. Sector capacity should be calculated for each weather forecast in EWF and the calculation of sector capacity should employ the above-mentioned trajectory prediction model and the improved complexity prediction model in its calculation method. All results from capacity calculation should be statistically characterized (Fig. 2).

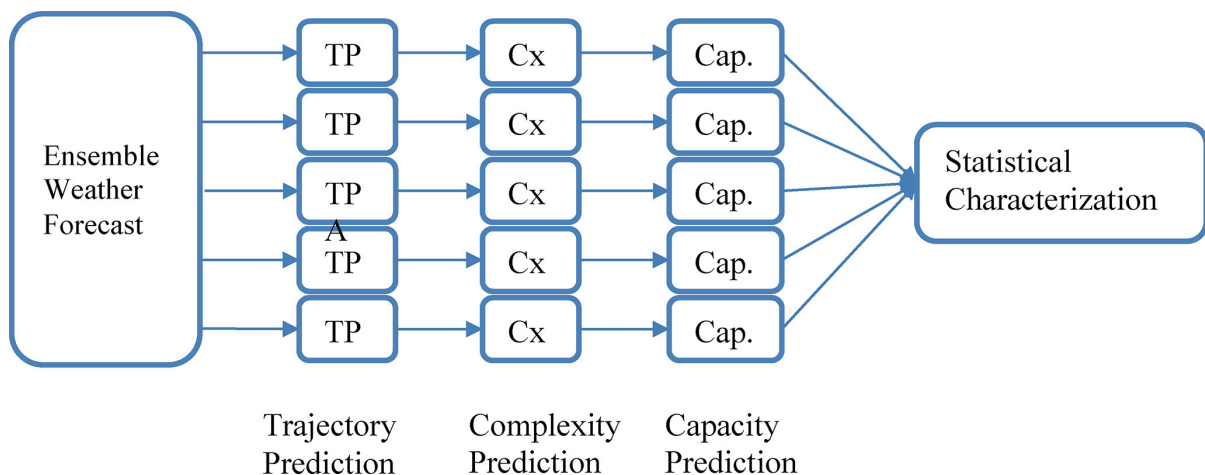

Fig. 2. Sector capacity prediction

5. Conclusions

By applying an improved air traffic complexity assessment method to the current trajectory prediction model, it is possible to increase the reliability of sector capacity prediction. Using such a method with Ensemble Weather Forecast will allow statistical characterization of predicted capacity in uncertain convective weather conditions.

To enable such a prediction, the current air traffic complexity model should be modified to calculate complexity at microscopic level with finer spatial and temporal resolution. Also, air traffic complexity model needs to be improved with a new indicator that will enable quantification of aircraft-weather interaction.

In further development, the developed method for calculating sector capacity will be used to optimize the sector opening scheme. For each forecast given by EWF it is possible to propose ideal sector opening schemes. With such a set of data Flow Manager Position (PMF) will be given prepared opening schemes for the person who created the forecast. Such information enables him to be better prepared for the upcoming traffic flow. Such information will enable him to be more prepared for the upcoming traffic flow.

Another application of predicted sector capacity is to help FMP decide which measures to apply to balance demand capacity. Demand capacity balancing measures are actions implemented by the FMP to reduce or balance workload of ATC. The proposed method can be used to determine which measure would have the minimum impact on aircraft operating costs and the environment in order to maintain maximum traffic flow in a given airspace. The most commonly used measures are sectorisation and changes in sector configuration, as the addition of more ATC does not have a negative impact on aircraft. But in situations where resources are limited, FMPs use measures such as short term air traffic flow and capacity management measures (STAM). As stated in the introduction STAM measures include short notice ground regulations, ground delay, Take Off Not Before, Take Off Not After, re-routing, change in standard instrument departure, flight level reassignment, level capping, and speed regulations. The complexity model can be used to determine the effect of various measures on air traffic complexity. With such calculations it is possible to determine an almost optimal set of measures to reduce the initial complexity and thus help FMT to increase or balance the capacity.

References

- [1] STATFOR Team, »EUROCONTROL Seven-Year Forecast October 2018, « Brussels, 2018.
- [2] STATFOR Team, »EUROCONTROL Seven-Year Forecast FEBRUARY 2018, « Brussels, 2018.
- [3] STATFOR, »European aviation in 2040, « Brussels, 2018.
- [4] C. G. Davis, J. W. Danaher and M. A. Fischl, »The influence of selected sector characteristics upon ARTCC controller activities, « The Matrix Corporation, Arlington, 1963.
- [5] D. K. Schmidt, »On Modeling ATC Work Load and Sector Capacity, « Journal of Aircraft, issue. 13, no. 7, pp. 531-537, July 1976.
- [6] M. Hurst and R. Rose, »Objective job difficulty, behavioral response, and sector characteristics in air route traffic control centres, « Ergonomics, br. 21, pp. 697-708, 1978.
- [7] E. Stein, »Air traffic controller workload: An examination of workload probe, « Atlantic City, New Jersey, USA, 1985.
- [8] P. Kopardekar and S. Magyarits, »Dynamic density: measuring and predicting sector complexity, « The 21st Digital Avionics Systems Conference Proceedings, Irvine, CA, USA, 2002.
- [9] P. Kopardekar, A. Schwartz, S. Magyarits and J. Rhodes, »Airspace Complexity Measurement: An Air Traffic Control Simulation Analysis, « US/Europe 7th Air Traffic Management Seminar, Barcelona, 2007.
- [10] A. Masalonis, M. Callahan and C. Wanke, »Dynamic Density and Complexity Metrics for Real-Time Traffic Flow Management, « Proceedings of the 5th USA/Europe Air Traffic Management R&D Seminar, Budapest, Hungary, 2003.
- [11] A. Klein, M. Rodgers and K. Leiden, »Simplified dynamic density: A metric for dynamic airspace configuration and NextGen analysis, « IEEE/AIAA 28th Digital Avionics Systems Conference, Orlando, USA, 2009.
- [12] EUROCONTROL, »A complexity study of the Maastricht upper airspace centre, « EUROCONTROL, Brétigny-sur-Orge, 2006.
- [13] EUROCONTROL, »Complexity Metrics for ANSP Benchmarking Analysis, « Brussels, 2006.
- [14] SESAR JU, Enhanced DCB OSED for Step1, SESAR JU, 2016.
- [15] J. Krozel, J. Mitchell, V. Polishchuk and J. Prete, »Capacity estimation for airspaces with convective weather constraints, « u AIAA Guidance, Navigation and Control Conference and Exhibit, Hilton Head, 2007.
- [16] A. Nilim, L. E. Ghaoui, V. Duong and M. Hansen, »Trajectory-based Air Traffic Management (TB-ATM) under Weather Uncertainty, « Proceedings of the USA/FAA Air Traffic Management R&D Seminar 2001, Santa Fe, 2001.
- [17] R. DeLaura, M. Robinson, M. Pawlak and J. Evans, »MODELING CONVECTIVE WEATHER AVOIDANCE IN ENROUTE AIRSPACE, « 13th Conference on Aviation, Range, and Aerospace Meteorology (ARAM), New Orleans, LA, 2008.
- [18] D. McNally, K. Sheth, C. Gong, J. Love, C. Han Lee, S. Sahlman and J.-H. Cheng, »Dynamic weather routes: a weather avoidance system for near-term trajectory-based operations, « 28th International Congress of the Aeronautical Sciences, Brisbane, 2012.
- [19] D. Hentzen, M. Kamgarpour, M. Soler and D. González-Arribas, »On maximizing safety in stochastic aircraft trajectory planning with uncertain thunderstorm development, « Aerospace Science and Technology, br. 79, pp. 543-553, 2018.
- [20] J. Y. N. Cho, J. D. Welch and N. K. Underhill, »Analytical Workload Model for Estimating En Route Sector Capacity in Convective Weather, « u Ninth USA/Europe Air Traffic Management Research and Development Seminar (ATM2011), Berlin, 2011.

- [21] J. D. Welch, J. Y. N. Cho, N. K. Underhill and R. A. DeLaura, »Sector Workload Model for Benefits Analysis and Convective Weather Capacity Prediction, « u Tenth USA/Europe Air Traffic Management Research and Development Seminar (ATM2013), Chicago, 2013.
- [22] J. A. Hadley and R. L. Sollenberger, »Dynamic resectorization of airspace boundaries between adjacent air route traffic control centers, « u Focusing Attention on Aviation Safety, Columbus, 2001.
- [23] A. Klein, P. Kopardekar, M. Rodgers and H. Kaing, »" Airspace Playbook": Dynamic Airspace Reallocation Coordinated with the National Severe Weather Playbook,« u 7th AIAA ATIO Conf, 2nd CEIAT Int'l Conf on Innov and Integr in Aero Sciences, 17th LTA Systems Tech Conf; followed by 2nd TEOS Forum, Belfast, 2007.
- [24] A. Klein, M. D. Rodgers and H. Kaing, »Dynamic FPAs: A new method for dynamic airspace configuration, « 2008 Integrated Communications, Navigation and Surveillance Conference, Bethesda, Maryland, 2008.
- [25] J. Mitchell, V. Polishchuk and J. Krozel, »Airspace throughput analysis considering stochastic weather, « AIAA Guidance, Navigation, and Control Conference and Exhibit, Keystone, 2006.
- [26] C. Meckiff, C. Renaud, and N. Jean-Pierre »The tactical load smoother for multi-sector planning, « Proceedings of the 2nd usa/europe air traffic management research and development seminar. 1998.
- [27] R.H. Mogford, J. Guttman, S. Morrow, P. Kopardekar, »The Complexity Construct in Air Traffic Control: A Review and Synthesis of the Literature, « CTA INC MCKEE CITY NJ; 1995.