

Thermoelectric cells cogeneration from biomass power plant: literature review

Augusto Bianchini, Filippo Donini, Marco Pellegrini
DIN, Facoltà di Ingegneria, Università di Bologna
Viale Risorgimento, 2 – 40136 – BO

Abstract

Thermoelectric cells convert directly heat into electricity but, due to the low conversion efficiency (up to 5%), most applications are in waste heat recovery. Another promising application is in biomass boiler. In this case, the installation of thermoelectric modules converts a biomass boiler into a cogeneration system, where the aim of the integration is not the electricity production for external power supply, but the realization of a stand-alone biomass power plant which could match the customer needs in isolated places. This review is focused on the recent research papers in thermoelectric biomass cogeneration.

1. Introduction

In developing countries, the electrical network is typically reliable only in the main cities, furthermore in the rural areas biomass combustion is the main energy source. Usually the biomass combustor used is an open fire stove, which is characterized by a low combustion efficiency. Low combustion efficiency means an inefficient use of the fuel and an unhealthy air pollution (1). An improved stove has to be designed and installed to gain higher energy combustion performance. Due to the lack of electricity network, the electric power required by the improved stove, for example to feed an electrically powered air fan, has to be produced in loco, preferably with renewable resources (RESs). The main low cost available technology is the photovoltaic conversion, but in the winter season, when the biomass stove is used, photovoltaic systems provide the worst performances. An alternative option is the use of thermoelectric cells or thermoelectric generators (TEGs), which can convert directly the heat produced by biomass combustion into electricity through the Seebeck effect (2). The TEG power generation has the advantages of being maintenance free, silent in operation and involving no moving or complex parts. So, the thermoelectric cells could improve the system efficiency with the electricity production. Due to cell's low efficiency in heat conversion into electric energy (up to 5%), the aim of the integration is not the electricity production for external power supply, but the realization of a stand-alone biomass power plant.

However, the applications of the TEG technology are numerous and in continuous development. The main challenge is finding the best integration with the heat generator, in order to ensure top operating conditions for TEG. In 2014, Hasan Nia and Abbas Nejad studied the application of thermoelectric cells with a solar concentrator: the concentrated solar beam heats up reservoirs full of mineral oil, then the heat absorbed by this fluid transfers to water reservoir which is connected by thermoelectric modules. The system layout is shown in Figure 1 (3).

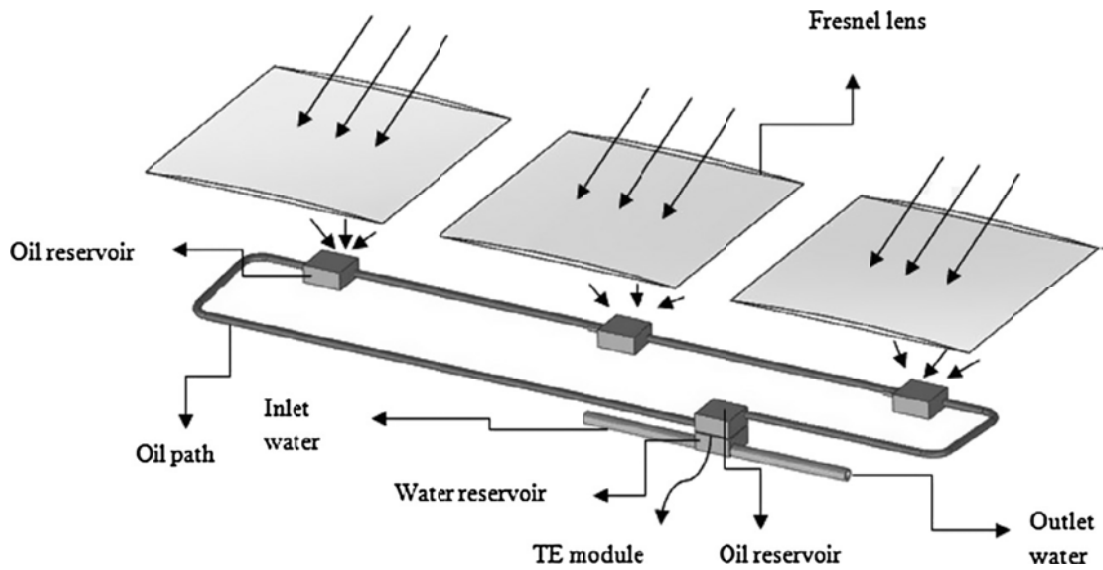

Figure 1 Schematic of the Hasan Nia et al. proposed design (3)

Other applications of TEG can be in the internal combustion engines, both for stationary electric generation and for automotive, with TEGs working between the exhaust stream and the motor cooling water. In this regard Kerri et al. in 2010 demonstrated that the advantages of the TEG technology application are lower in the automotive case, because of the more power required to transport the TEG system weight (4). Bekir and Ahmet in 2013 studied a combined thermal system consisting of a TEG and a refrigerator. They found that the best position where the TEG should be installed is between the condenser and his ambient, as shown in Figure 2. In this way is possible to improve the coefficient of performance of the refrigeration plant (5).

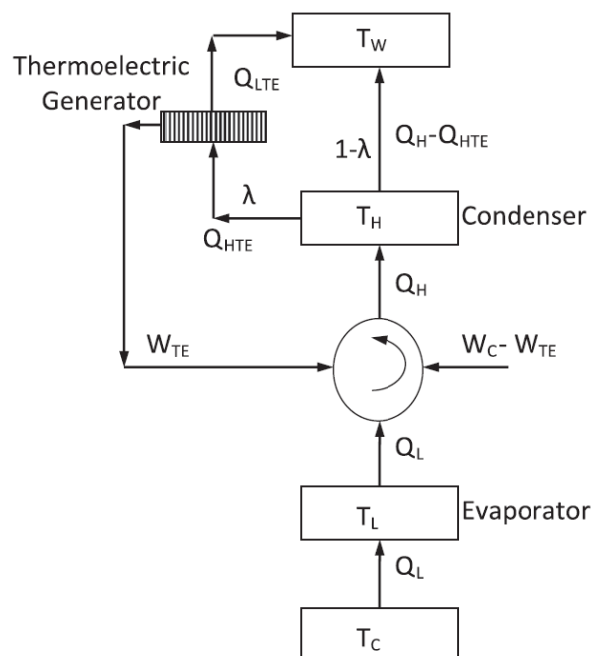

Figure 2 Schematic of Yilbas et al. TEG application in a refrigeration cycle (5)

The aim of this article is to make a brief literature review of the integrations of thermoelectric technology with other plants. In particular the focus will be on applications of thermoelectric cells in biomass power plants.

Nomenclature			
A	Cross area of the thermoelement [m ²]	T _H '	Measured hot temperature [K]
L	Length of thermoelement [m]	T _C '	Measured cold temperature [K]
L _C	Thickness of solder/contact in the module [m]	T _{HF}	Hot fluid average temperature [K]
m	Electrical load ratio	T _{CF}	Cold fluid average temperature [K]
n	Resistivity contact parameter	TEG	Thermoelectric Generator
N	Number of thermoelements per module	V _{OC}	TEG open circuit voltage [V]
P	Power [W]	α	TEG Seebeck coefficient [V/K]
r	Conductivity contact parameter	ΔT	Hot-cold TEG temperature difference [K]
R	Electrical resistance of TEG [Ω]	ρ	TEG electric resistivity [Ωm]
R _L	Load electrical resistance [Ω]	ρ _c	Contact electric resistivity [Ωm]
RES	Renewable Energy Resources	λ	TEG thermal conductivity [W/mK]
T _H	TEG hot temperature [K]	Λ _c	Contact thermal conductivity [W/mK]
T _C	TEG cold temperature [K]	η	TEG conversion efficiency

2. Thermoelectric power generation and biomass power plant

2.1 Thermoelectric Background and power generation

In 1822 *Seebeck* first discovered the thermoelectric effect. He observed an electric flow when the junction of two dissimilar metals, joined at two places, was heated whole the other junction was kept at a lower temperature. The output produced was initially of small magnitude but with the discovery of the semiconductor properties, it was found that the electrical output could be significantly increased. So in the TEG a temperature difference between two different semiconductors creates a voltage. TEG are composed by a set of semiconductor components formed by two different materials; these components are connected thermally in parallel, thanks to an electric insulating layer (typically in ceramic materials), and electrically in series, thanks to metal connectors.

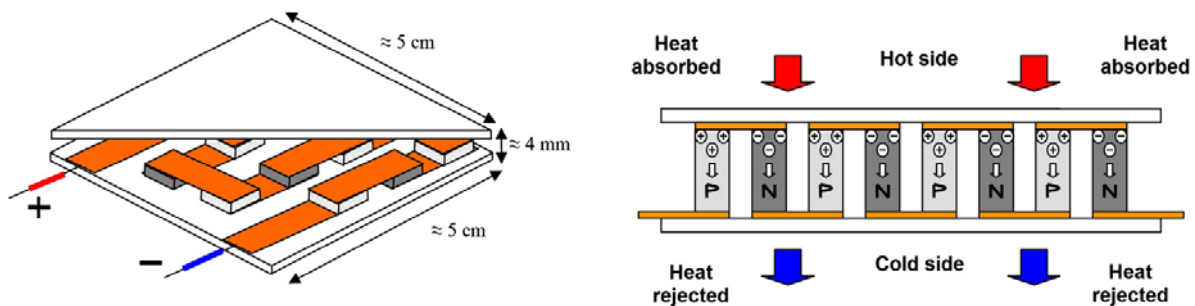

Figure 3 Seebek Cell (2).

Figure 3 provides a schematic of the operation of a thermoelectric cell. The P and N materials are two different semiconductors. When the heat flows from the hot side to the cold one, the

n-semiconductors are loaded negatively (excess of electrons) and the p-semiconductors are loaded positively (deficit of electrons). Thanks to the electrical series connection, between the first n-semiconductor and the last p-semiconductor a voltage is generated. The parameter giving the output voltage for a given couple of materials and for a given temperature difference between the cold side and the hot one is the *Seebeck* coefficient, α . This coefficient is in the range of 0-50 mV/K for metals, and over 300 mV/K for semiconductors.

As explain by Rowe and G. Min in 1998, a realistic estimate of the power output is obtained if we take into account the thermal and electrical contact resistance (6). The power output (P) and the open circuit voltage (V_{OC}) are given by Equation 1 and Equation 2:

$$P = \frac{2m}{(1+m)^2} \frac{\alpha^2}{\rho} \frac{NA(T_H - T_C)^2}{(L+n)(1+2r^{L_c/L})} \quad (1)$$

$$V_{OC} = 2N\alpha(T_H - T_C) \quad (2)$$

where m, n and r are, respectively, the ratio between the load electric resistance and the TEG module resistance, the ratio between contact resistivity and thermoelectric module electric resistance ($m=R_L/R$), the ratio between contact resistivity and thermoelectric module resistivity ($n=\rho_c/\rho$) and the ratio between contact conductivity and thermoelectric module conductivity ($r=\lambda_c/\lambda$). The parameters A, N, L and L_c are defined in the nomenclature. For a given p-n junction the parameter that gives, if multiplied by the hot-cold side temperature difference, the voltage is the “Seebeck coefficient”, α .

From the power equation it is clear that, regardless the other parameters, the maximum power is reached when there is a matched load ($m=1$), as shown in Figure 4.

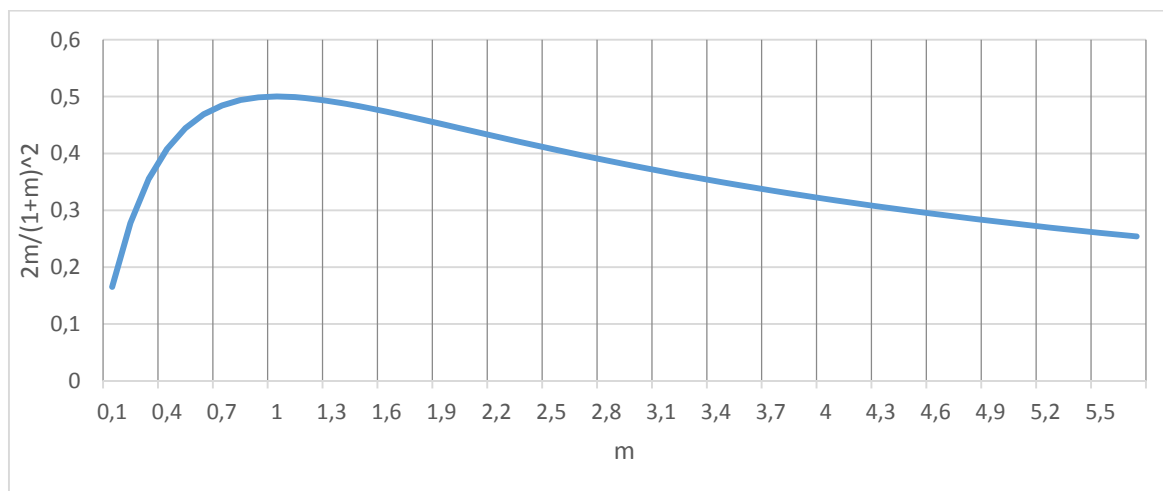

Figure 4 Effect of load factor on the power regardless the other parameters.

2.2 State of the art of thermoelectric generation from biomass combustion

TEGs can be used in boilers like heat exchanger between a hot fluid, i.e. the combustion flue gas, and a cold one, i.e. heating water. The heated cold fluid obtained will heat up the rooms that the boiler serves. In this sense is it possible to let the TEGs work in a cogeneration mode (7). In this configuration it is possible to produce electricity without wasting heat, and is also possible to use the produced electricity for feeding the boiler itself.

Many studies involve the installation of the TEG directly on the casing (external side) of the stove and foresee the clamping of a heat sink in the cold side of the cell. An air fan could be installed to cool down the heat sink (8).

Kilander and Bass first studied the application of thermoelectric cells to rural biomass stoves in Sweden in 1996 (8). The electric output obtained was sufficient for having light such as provided by a 12V small fluorescent light and for feeding a TV for 2 hours a day.

Before the modules installation it is important to study where the installation of the TEG is more suitable or rather where the casing temperature is higher and uniform. Nuwayhid et al. in 2005 installed a TEG generator (HZ-20) on the lateral wall of a domestic wood stove. On the cold side of the generator was installed a heat sink, which was naturally cooled. A maximum power output of 4,2 W for each cells was obtained at a hot temperature of 275 °C with a cold temperature of 123°C. An important result is the reduction of the power output if the number of TEGs installed is higher of two and if all the cells are cooled by the same heat sink (9).

In 2005 Nuwayhid et al. installed the TEG between the top-stove and a thermosyphonic closed loop heat exchanger. The fluid in the closed loop heat exchanger was water. Using HZ-20 module the power obtained was 3 W with a temperature difference of 70-80°C (10).

Lertsatitthanakorn in 2007 using a Chinese module (Taihuaxing model TEP1-1264) in a similar system configuration obtained 2,4 W at a temperature difference of about 150°C, reaching a conversion efficiency of 3,2 %. (11) Champier et al., in 2010 has carried out similar experiments with the same module. (2) Wei-Hsin Chen et al. in 2012 carried out another interesting result; the system was made up of a heater, aluminum plates, TEGs, heat sinks, a cold fluid loop, four compressive loads, an electronic load and a data acquisition unit. The flow rate of cooling water has been varied between 0,4 and 1,6 L min, with a constant temperature on the hot side, and it has been obtained that the flow rate affect the temperature difference across the module only slightly (12).

In 2013 Bianchini et al. have investigated the thermoelectric cells in a test facility which has been configured to reproduce, in scale, the working conditions of a typical biomass power plant (13). The module chosen for the experimental facility is the HZ-20 which gives interesting and demonstrated (8; 9; 10; 14) performance (i.e. power output and conversion efficiency).

Table 1 gives the main specification and properties of the cells. The HZ-20 cell gives under design conditions ($T_H=230^\circ\text{C}$, $T_C=30^\circ\text{C}$ and matched load) 19 W.

Table 1 Main Specifications and properties of the HZ-20 module.

Thermoelectrical material	Bismuth Telluride
Weight [g]	115
Module dimensions [mm]	75x75x5.08
Number of Couples	71
Maximum hot operating temperature T_H [°C]	250
Thermal Conductivity λ [W/mK]	2.4
Internal electric resistance R [Ω]	0.3

Under matched load conditions the power output and open circuit voltage of HZ-20 are (Equation 3 and Equation 4):

$$P = 5.0 * 10^{-4} * \Delta T^2 \quad (3)$$

$$V_{OC} = 0.026 * \Delta T \quad (4)$$

The test facility, which has been configured to reproduce in scale the working conditions of the integration of the TEG in a typical biomass power plant. In the test facility the hot flue gas at the hot side was reproduced by the outlet air of an industrial heat gun. The cold side of the cells was cooled by a water flow regulated by a control manual valve. The cell was compressed between stainless steel plates fixed by bolts fastening. The tightening value of the bolts fastening was set by a torque wrench. On the top and bottom plates a K-type thermocouple measured the value of the temperature. The set up facilities is shown in Figure 5.



Figura 5 Schematic overview of the test facility (13).

The main results published in this paper are:

- The contact surface quality between cells and both top and bottom plate influences the performances, i.e. a lower roughness means higher performances. (13; 14)
- A higher tightening value of the bolts fastening causes higher performances.
- The introduction of ceramic plates and thermal grease increase the surface heat uniformity but decrease the thermal conductivity. As consequence the addition of this two elements seems to be a good solution only when the heat source has a higher temperature than the cell maximum working temperature.
- The matched electrical load maximize the system performances, as predicted by the theory.

Accurate measurements of the conversion efficiency are difficult to obtain, because of the uncertainties about the real heat input absorbed at the hot side of the TEGs. This uncertainties are caused by the temperature unevenness on the hot side of the cell.

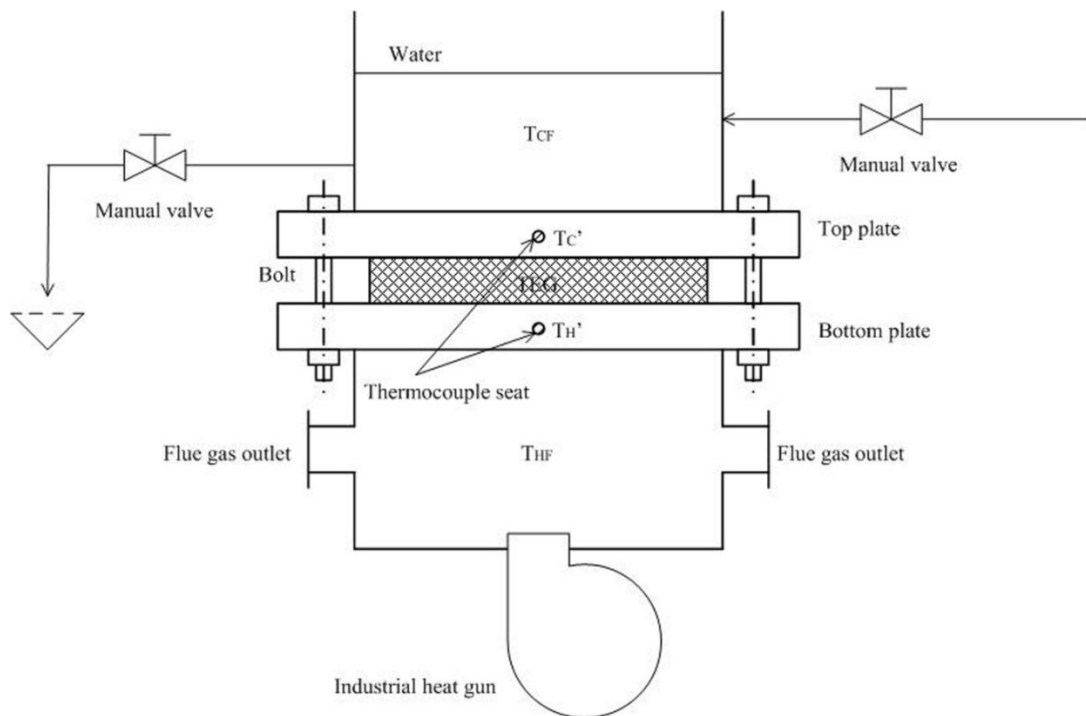
One of the best improvement that one could obtain is the hot temperature uniformity without the decreasing of the contact thermal conductivity of the system. The hot temperature uniformity helps to achieve the maximum cells conversion efficiency and permits an accurate measurement of the heat flux across the cell (i.e. of the equality of the local temperature, measured by the hot side thermocouple, and the average hot side temperature).

3 Conclusion

The paper reviewed the existing work about thermoelectric cells applications, especially in cogeneration from biomass power plant. The integration of thermoelectric generation in biomass power plant is not interesting for the electric power production for external supply but for the designing of a stand-alone biomass power plant. A stand-alone biomass power plant could match the customer needs in isolated places where the electricity network is not present.

One of the main improvement that one could obtain for the testing and the optimization of the thermoelectric integrations in a biomass power plant is the uniformity of the hot temperature. This fact could improve the system efficiency and makes the heat flux across the cell easily measurable. A new test facility where the uniformity of the hot side temperature is implemented could permit to understand the real technical/commercial feasibility of the thermoelectric cells cogeneration from biomass power plants.

References

1. *Evaluation of cooking energy cost, efficiency impact on air pollution and policy in Nigeria*,. **Anozie AN, Bakare AR, Sonibare JA, Oyebisi TO**. s.l. : Elsevier, 2007, Energy, Vol. 32, pp. 1283-90.
2. *Thermoelectric power generation from biomass cook stoves*. **Champier D, Bedecarrats JP, Rivaletto M, Strub F**. 35, s.l. : Elsevier, 2010, Energy, pp. 935-42.
3. *Cogeneration solar system using thermoelectric module and fresnel lens*. **Hasan Nia M, Abbas Nejad A, Goudarzi AM, Valizadeh M, Samadian P**. s.l. : Elsevier, 2014, Energy Conversion and Management, Vol. 84, pp. 305-10.
4. *Exhaust energy conversion by thermoelectric generator: Two case studies*. **Karri MA, Thacher EF, Helenbrook BT**. s.l. : Elsevier, 2010, Energy Conversion and Management, Vol. 52.
5. *Thermal characteristics of combined thermoelectric generator and refrigeration cycle*. **Bekir S. Yilbas, Ahmet Z. Sahin**. s.l. : Elsevier, 2014, Energy Conversion and Management, Vol. 83.
6. *Evaluation of thermoelectric modules for power generation*. **D.M. Rowe, Gao Min**. s.l. : Elsevier, 1998, Journal of Power Science, Vol. 73, pp. 193-98.
7. *"Symbiotic" application of thermoelectric conversion for fluid preheating/power generation*. **G Min, D.M. Rowe**. s.l. : Pergamon, 2002, Energy Conversion and Management, pp. 221-28.
8. *A stove-top generator for cold areas*. **Kilander A, Bass JC**. Pasadena, CA : s.n., 1996. Proceedings of 15th International Conference on Thermoelectrics (1996). pp. 390-93.
9. *Development and testing of a domestic woodstove thermoelectric generator with natural convection cooling*. **Rida Y. Nuwayhid, Alan Shihadeh, Nesreen Ghaddar**. 46, s.l. : Elsevier, 2005, Energy Conversion and Management, pp. 1631-43.
10. *Design and testing of a locally made loop-type thermosyphonic heat sink for stove-top thermoelectric generator*. **Nuwahid RY, Hamade R**. s.l. : Elsevier, 2005, Renewable Energy, Vol. 30, pp. 1101-16.
11. *Electrical performance analysis and economic evaluation of combined biomass cook stove thermoelectric (BITE) generator*. **Lertsatitthanakorn**. 98, s.l. : Elsevier, 2007, Bioresource Technology, pp. 1670-74.

12. *Experimental study on thermoelectric modules for power generation at various operating conditions.* **Wei-Hsin Chen, Chen-Yeh Liao, Chen-I Hung, Wei-Lun Huang.** s.l. : Elsevier, 2012, Energy, Vol. 45.
13. *Thermoelectric cells cogeneration from biomass power plant.* **Bianchini A, Pellegrini M, Saccani C.** Bologna : Elsevier, 2014, Energy Procedia, Vol. 45, pp. 268-77.
14. *Low cost stove-top thermoelectric generator for regions with unreliable electricity supply.* **Nuwayhid RY, Rowe DM, Min G.** s.l. : Elsevier, 2003, Renewable Energy , pp. 205-22.