

# Modelling and Simulation of the Performance Analysis for Peltier Module and Seebeck Module using MATLAB/Simulink

K.N. Khamil<sup>a,b</sup>, M.F.M. Sabri<sup>a\*</sup>, A.M. Yusop<sup>b</sup>, R. Mohamed<sup>c</sup> & M.S.Sharuddin<sup>b</sup>

<sup>a</sup>Department of Mechanical Engineering, University of Malaya, Malaysia

<sup>b</sup>Advance Sensor and Embedded Control Research Group

Centre for Telecommunication Research & Innovation

Faculty of Electronic Engineering and Computer Engineering, Universiti Teknikal Malaysia Melaka, Malaysia

<sup>c</sup> Department of Electrical, Electronic and Systems Engineering, Unversiti Kebangsaan Malaysia

\*Corresponding author : faizul@um.edu.my

Received 20 February 2019, Received in revised form 18 June 2019

Accepted 15 April 2020, Available online 30 May 2020

## ABSTRACT

Currently, the technologies used in power generation are not fully optimised and inefficient. The waste energy produced from the machines, systems and the infrastructure have created interest in energy harvesting researches especially the world is entering the Industrial Revolution 4.0 (IR4.0). This paper investigates the analytical modelling for both Peltier and Seebeck module in terms of the main parameters needed for quick evaluation depending on user's application such voltage, current, coefficient of performance and the efficiency, thermal resistivity, total internal resistance, and Seebeck coefficient of the module. These parameters are normally given by manufacturer of the module through the datasheet. MATLAB/Simulink was used to simulate from the base equations. Graph representation of the output can be generated using several codes on Matlab command window. The simulation was tested on TEPI-1994-3.5 and TES1-05350 where the results obtained agrees well with the datasheet provided by the manufacturer which proved the MATLAB/Simulink's modelling. The real experiment data using Peltier Module, APH-127-10-25-S proved the analytical modelling with the percentage error between simulation real experiments of 0.45% where the analytical simulation estimates the voltage output is 1.6340 V while the experimental voltage output from the in-lab experiment is 1.6266 V at hot temperature of 61°C and cold temperature of 27.5°C.

**Keywords:** peltier; seebeck; analytical modeling; thermoelectric; matlab; simulink

## INTRODUCTION

Energy efficiency and power management become the core component when the Internet of Things (IoT) developed to be the backbone of the Industrial Revolution 4.0 (IR4.0) where most of the

electronic application are connected to each other (Morin, September 12, 2017, i-SCOOP.eu, 2018). The power usage of the connected devices has increase rapidly which results in the rise of energy cost. Hence, the energy harvesting method for

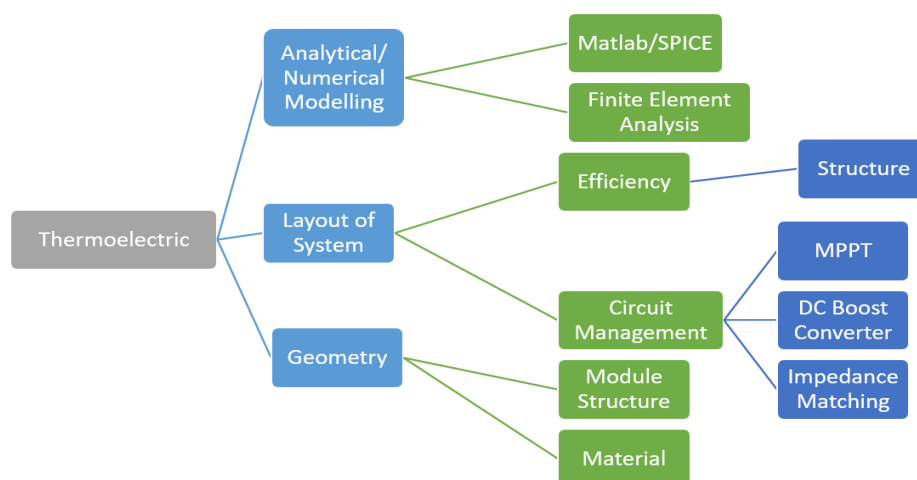

FIGURE 1. Research areas for Thermoelectric Energy Harvesting (TEH)

waste heat recovery such thermoelectric (TE), piezoelectric, and solar helps reduced the cost in power system (Bogue, R, 2015), (Bonisoli, E., Luc, D., Dr Guillaume Crevecoe, P., Di Monaco, F., Tornincasa, S., Freschi, F., Repetto, M., 2014), (Bonisoli, E., Manca, N., & Repetto, M., 2015), (Zafar, M., Naeem Awais, M., Asif, M., Razaq, A., & Amin, G., 2017), (Mohamed, R., Yusop, A. M., Mohamed, A., & Nordin, N. I., 2016).

Over the past few years, there are rise of interest for TE to be used in a lower power application or devices such wireless transceiver for data acquisitions purposes and sensors application. There are immense of element in TE can be explored as shown in Figure 1 that can be categorized in few areas. In material studies, researchers are focusing on lower ZT materials with a high figure of merit in order to achieve high efficiency for TE where the elements like Mg–Mn silicides are seen as alternative thermoelectric materials to bismuth telluride, for the mid-temperature range that have high thermoelectric performances (Twaha et al., 2016) which falls under the areas of TE's geometry development. Whereas, the studies in layout of the system as shown in Figure 1 vary according to the application of the thermoelectric generator system (TEGS) from automation, house appliances like cook stove to water heater and many more. In the circuit management areas under the category of layout for the TEH system such M.R.Sarker, NA.Mohamed, R. Mohamed (2016), proposed a technique to run a low power electronics applications that can be applied to boost up the voltage output in TEG by utilized the voltage doubler and bridgeless boost rectifier circuit to increase the output voltage (M.R.Sarker, A.Mohamed, R. Mohamed, 2016).

The method successfully increases the voltage from 0.9 V to 3 V where the efficiency rises tremendously from 6.1% to 71%. Meanwhile, J.Sampe, N.A.A. Semsudin, F.F.Zulkifli, & B.Y. Majlis (2017) demonstrated the ability to harvest three form of energy (RF, thermal and vibration) where it managed to get an output of 2.12 V.As for improving the performance efficiency, method of power conditioning using DC-DC converter shows a significant power output where it enhanced the effectiveness of the system (J.Sampe, N.A.A. Semsudin, F.F.Zulkifli, & B.Y. Majlis., 2017).

For instance, in marine application, the energy harvesting system (EHS) utilized the temperature gradient between hot lube oil inside azimuth thruster and cold sea water outside thruster where it used different configuration and material to enhance the performance of EHS, an enclosure is added to increase the temperature gradient (Tang et al., 2017). Meanwhile, Favarel, C., Bédécarrats, J.-P., Kousksou, T. & Champier, D demonstrated the performance improvement when the structures are designed in three different configurations with

different number of modules, different temperatures and different airflow rate (Favarel, C., Bédécarrats, J.-P., Kousksou, T., & Champier, D, 2015). For these reasons, the process of development and testing which includes research in the modelling and simulation areas are crucial for product development to predict the performance of the system first hand before developing it instantaneously. There are significant amount of Peltier and Seebeck module in the market for cooling application and power generation. A considerable amount of literature has been published on analytical modelling for the thermoelectric power generator.

For instance, Wu Chih (1996) has presented a numerical analysis of waste-heat thermoelectric power generators in several cases in terms of external and internal irreversible heat engine. The analysis made on the heat equation can be used for numerical simulation which can give much more realistic generator specific power and efficiency prediction than the ideal thermoelectric generator. Meanwhile, Simon Lineykin and Sam Ben-Yaakov (2005) presented the modelling and analysis of thermoelectric modules using SPICE (Lineykin and Ben-Yaakov, 2007). Similarly, Mitrani, Daniel et. Al (2009) also shows a one-dimensional modelling of TE devices but it only considered temperature dependent parameters using SPICE (Mitrani et al., 2009). Both (Mitrani et al., 2009, Lineykin and Ben-Yaakov, 2007) used SPICE as a method of analysis where the governing equation are based on steady-state lumped parameter three-port electrical model and the equivalent circuit under steady state condition. However, very few researchers made their analysis using MATLAB/Simulink. Regardless, how much progress of TE faces, numerical analysis using computer simulation will help to expedite the improvement of TE development for various applications.

Therefore, in addressing the mentioned issues and research gaps, this project is focused on using an analytical modelling for Peltier and Seebeck module developed using MATLAB/Simulink which will be able to estimate the performances specific parameters needed for specific user application of any on-the-shelf module. In addition, the operating principle and the analytical modelling simulation are discussed, and their performances are validated with manufacturer's datasheet and in-lab experiment as well. The rest of the paper is organized as follows. Section 2 presents the basic theory of thermoelectricity. Section 3 discusses the base equations used for the analytical modelling simulated using MATLAB/Simulink and the experimental setup are clearly demonstrated. The experiment results and the discussions are shown in Section 4 and conclusions are drawn in Section 5.

There are two types of TE module in the market, Peltier module and Seebeck Module where Peltier modules are used for the application of cooling and power generation. Meanwhile, Seebeck Module is only use for heat generation. The Seebeck effect stated the electromotive force (emf) or voltage are produced after a significance temperature difference formed by two dissimilar metals or semiconductor:

$$\alpha_{12} = V/\Delta T \tag{1}$$

The dissimilarity of Seebeck coefficient between material 1 and 2 is noted as  $\alpha_{12}$ , the temperature variation labelled as  $\Delta T$  and the emf or voltage as  $V$ . In Peltier effect, when current is applied continuously into the conductor, full cycle is formed and if different material is used, one junction in the cycle or loop will be cold and the others will be hot.

$$Q_{peltier} = \alpha \Delta T I \tag{2}$$

I stated as current flows in the loop or thermocouple. Hence, these fundamental theories are used for the operation of the TE module (TEM). The commercial TEM is coupled parallel to each other in thermal while in terms of electrical, the thermocouple is connected in series. And the number of thermocouples varies to output Thermoelectric module comprises of an array of thermocouples, connected in series, electrically and in parallel, thermally as shown in Figure 2(c).

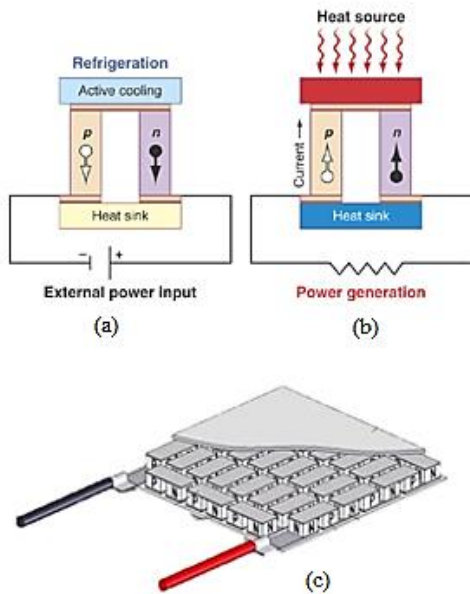

FIGURE 2.(a) Peltier Effect (b) Seebeck Effect (c) Commercial module is an array of thermocouple sandwiched in between two ceramic plates.

Analytical Modelling

In this study, analytical modelling is performed for both Peltier module and Seebeck module to verify

the basic characteristic of these modules which are stated in the manufacturer datasheets

i) Fundamental equation for Peltier Module

According to previous researches (Ivaylo et al., 2017, Lineykin and Ben-Yaakov, 2007), features between Peltier and Seebeck module are similar to each other. Even though Peltier modules can be used for power generation by heating up the cold side of the modules, the performance is more efficient in the temperature range of 20 °C and 40 °C (Nesarajah and Frey, 2016). Most manufacturers of Peltier have set the following parameters to  $\Delta T_{max}$ ,  $V_{max}$ ,  $I_{max}$  and the hot side temperature.

Therefore, using the information given from datasheet, the parameters needed for analytical modelling are: -

$$Z = \frac{R_{th} \cdot \alpha_m^2}{R_{int}} \tag{3}$$

$$\alpha_m = \frac{V_{max}}{T_h} \tag{4}$$

$$R_{int} = \frac{V_{max} (T_h - \Delta T_{max})}{I_{max} T_h} \tag{5}$$

$$R_{th} = \frac{\Delta T_{max}}{I_{max} V_{max}} \frac{2T_h}{(T_h - \Delta T_{max})} \tag{6}$$

where  $R_{th}$  is thermal resistivity,  $R_{int}$  is total internal resistance of the module and  $\alpha_m$  is the Seebeck coefficient of the module. The performance of the module is analyzed in terms of the coefficient of

performance (C.O.P) where  $C.O.P = \frac{Q}{VI}$ . (7)

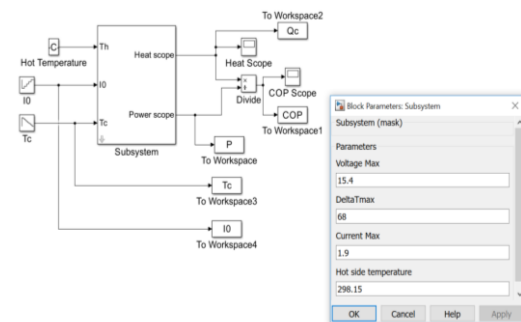

FIGURE 3. Main block diagram of Peltier Module The expression of voltage, V is noted as

$$V = \alpha_m \Delta T + IR_{int} \tag{8}$$

While the heat absorbed,  $Q$  is given as

$$Q = \alpha_m IT_C - 0.5^2 IR_{int} - \frac{\Delta T}{R_{th}} \quad (9)$$

However, if the Peltier module is used for power generation, Palacios, R., Arenas, A., Pecharromán, R. R., & Pagola, F. L. (2009) stated that the heat emitted as

$$Q = \alpha_m IT_H - 0.5^2 IR_{int} + \frac{\Delta T}{R_{th}} \quad (10)$$

And the voltage for power generation using Peltier module is

$$V = \alpha_m \Delta T - IR_{int} \quad (11)$$

The efficiency of the module for heat generation is now noted as

$$\eta(m) = \frac{V \cdot I}{Q} \quad (12)$$

Figure 3 shows the main block diagram of Peltier Module where the specification of the module is entered in the ‘Subsystem’ block Parameter such  $\Delta T_{max}$ ,  $V_{max}$ ,  $I_{max}$  and the hot side temperature. Current,  $I_0$  and  $T_c$  will be varies using *Repeating Sequence Stair* block from the Simulink according to user application.

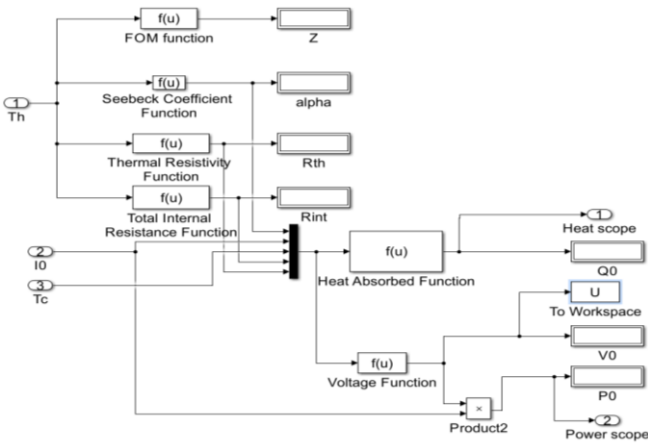

FIGURE 4. Detailed subsystem block diagram of Peltier

Figure 4 shows the detailed main diagram of the modelling from the governing equations (3) – (8). Each equation is entered in ‘function’ block diagram as shown above. However, with MATLAB/Simulink, the output generated is stacked in a single column which made it difficult to plot the results for several conditions of the parameters. For this reason, the analytical of the base-dependence for Peltier can be model using the MATLAB code shown in Figure 5.

```

1 - N = 127;
2 - deltatmax = 68;
3 - Imax = 1.9;
4 - Umax = 15.4;
5 - Th = 298.15;
6
7 - z0 = (2.*deltatmax)./((Th-deltatmax).^2);
8 - alpha = Umax./Th;
9 - rth = (2.*Th.*deltatmax)./((Th-deltatmax).*Umax.*Imax));
10 - rint = ((Th-deltatmax)*Umax)./(Th.*Imax);
11
12
13 - [I0, Tc] = ndgrid(0:0.01:1.9, 341.15:-5:298.15);
14 - Q0 = ((alpha .* I0 .* Tc) - (0.5 .* I0 .* rho)
15 -       - ((Th-Tc)./rth));
16 - U0 = alpha.*(Th-Tc)+(I0.*rint);
17 - W0 = U0.*I0;
18 - COP = Q0./W0;

```

FIGURE 5. MATLAB coding for Peltier analytical base dependence.

ii) *Fundamental equation for Seebeck Module*

In analyzing Seebeck module, most common specification shown in the manufacturer datasheet would be the match load power,  $W_m$ , match load voltage,  $V_m$  with given temperature at both hot and cold side,  $T_h$  and  $T_c$  where some manufacturer provided the optimal efficiency and internal resistance,  $\eta_m$  and  $R_{int}$ . Similar to Lineykin, S., & Ben-Yaakov, S., (2007), from given specifications, the analytical modelling for the below parameters is specified as:

$$Z = \frac{2}{T_h + T_c} \left( \left( \frac{(T_h - T_c) + \eta_m T_c}{(T_h - T_c) - \eta_m T_c} \right)^2 - 1 \right) \quad (13)$$

$$\alpha_m = \frac{2V_m}{(T_h - T_c)} \quad (14)$$

$$R_{int} = \frac{V_m^2}{W_m} \quad (15)$$

However, as the load,  $R_{load}$  of the system changes the efficiency changes as well and this effect the  $R_{th}$  since  $R_{load} = R_{int} \cdot m$  and  $m$  is noted the ratio of the resistance between the load and internal resistance.

$$I = \frac{T_h - T_c}{R_{int}(1 + m)} \alpha_m \quad (16)$$

Therefore, the efficiency  $\eta_m = f(I)$  is: -

$$\eta(m) = \frac{I^2 R_{int}}{q_h} = \frac{2 \cdot Z \cdot m \cdot (T_h - T_c)}{2(1 + m)^2 + Z(T_h + 2mT_h + T_c)} \quad (17)$$

$$R_{th} = \frac{R_{int}}{\alpha_m^2} Z \tag{18}$$

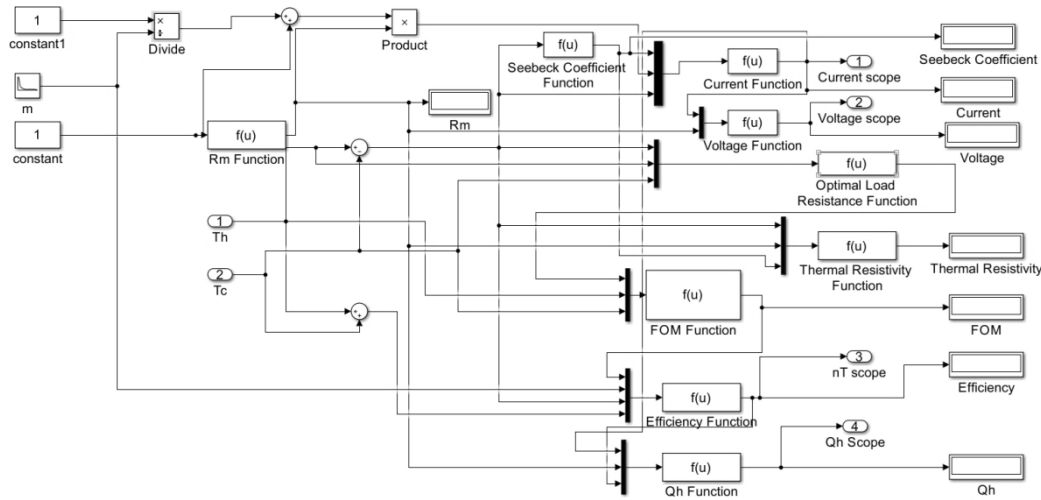

FIGURE 6 Details of MATLAB/Simulink block diagram for Seebeck module under the Subsystem block diagram

By referring to Figure 6, the same Peltier’s base block diagram was built where the parameter from the given specification in the manufacturer datasheet are entered. The parameters such as the match load power,  $W_m$ , match load voltage,  $V_m$  with given temperature at both hot and cold side,  $T_h, T_c$  and occasionally the optimal efficiency and internal resistance,  $\eta_m$  and  $R_{int}$  are given too. Meanwhile, Figure 6 presents the modelling of the equations (13)-(18).

Numerical simulations are performed to analyzed the cooling application and power generation for both Peltier and Seebeck Module. The results obtained from the Peltier module and the Seebeck module are evaluated as a function of temperature difference ( $DT$ ), current and voltage.

Results and Discussion

To prove the governing equations shown, two on-the-shelf modules are analysed between Peltier and Seebeck Module according to the specification provide by the manufacturer as shown in Table 1.

Peltier Module	TES1-05350	Seebeck Module	TEP1-1994-3.5
$\Delta T_{max}$	70 °C	$V_m$	6.7 V
$V_{max}$	6.8 V	$W_m$	7.5 W
$I_{max}$	5 A	$T_h$	300 °C
$T_h$	27 °C	$T_c$	30 °C
		$\eta$	5.5%

TABLE 1 Specifications of Peltier and Seebeck Module (Thermonamic Module: TES1-05350, 2017), (Thermonamic Module: TEP1-1994-3.5, 2017).

Once calculated, the result is displayed in the graph of Figure 7, where  $Q_0$ , heat removed from the module versus the  $DT$  of different currents shows the importance of the performance of the module. The numerical simulations show that at  $DT= 30^\circ C$  and current,  $I_0 = 5 A$ , the heat absorbed,  $Q_0$  is 11.98 W.

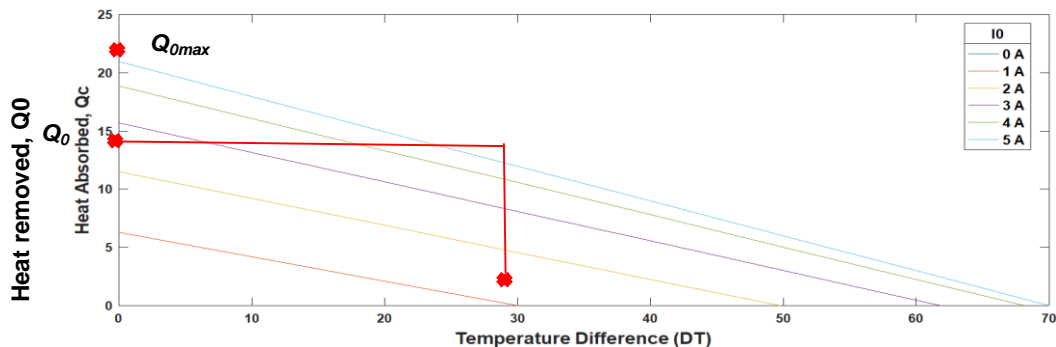

FIGURE 7 Heat removed versus temperature difference,  $DT$  at  $T_h = 27^\circ C$

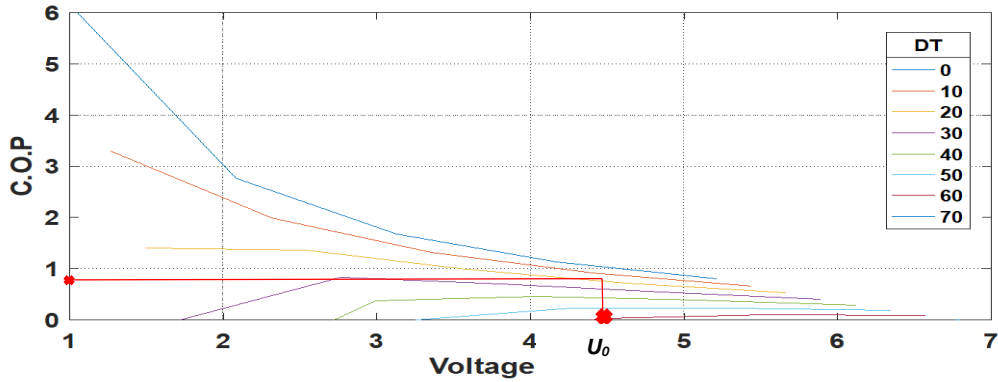

FIGURE 8 Coefficient of performances, *C.O.P* versus voltage,  $U_0$  at  $T_h = 27^\circ\text{C}$

This confirms the datasheet from the manufacturer which gives good agreement,  $Q_0 = 12 \text{ W}$ . Since there will uncounted thermal losses from the contact with the ambient air or the clammer,  $Q_0$  must balance any heat sources on the module cold side. The results also established the datasheets specifications where the  $Q_{0\text{max}}$  obtained is 20.96 W.

In (Adaptive Thermal Management, 2018), to reduce electricity usage and reduce the waste heat produced, a high C.O.P are necessary, but it depends on the stability on the reasonable driving power or DT and the efficiency of the module. However, higher C.O.P only achievable at lower DT. The results, as shown in Figure 8 above, indicate that when  $DT= 20^\circ\text{C}$  and  $U_0 = 4.5 \text{ V}$ , C.O.P is 0.72 which confirmed by the modelling.

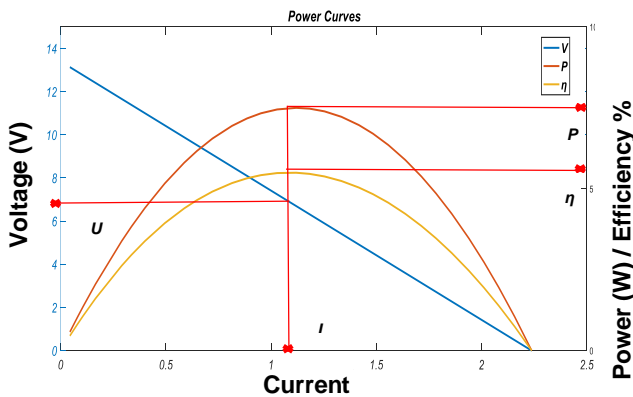

Figure 9 Current-Voltage curve of the Seebeck module

Further analysis for Seebeck module shown in Figure 9 where the power curve proved the current obtained are 1.194 A at match load condition, similar to the match load current from the manufacturer’s datasheet listed in Table 1 which are  $U_0 = 6.7 \text{ V}$ ,  $W = 7.5 \text{ W}$  and  $\eta = 5.5 \%$ .

To prove this modelling even further, an in-lab experiment is done where the analytical modelling simulation follows the equations (10) – (11).

The equations were transferred into the block diagram in Figure 4 for heat generation application and the condition was simulated according to the in-lab experiment setup (Khamil, K.N.; Sabri, M.F.M.; Yusop, A.M.; Sharuddin, M.S., 2018). Depicted in Figure 10 below are the experiment data using Peltier Module, APH-127-25-S where the experimental voltage output from the in-lab experiment is 1.6266 V at  $T_H = 61^\circ\text{C}$  and  $T_C = 27.5^\circ\text{C}$ .

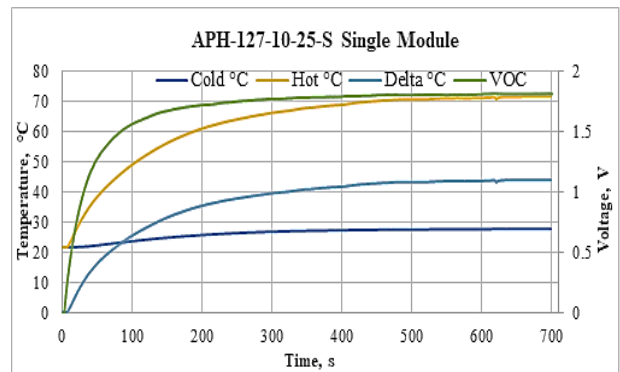

Figure 10 In- Lab experimental result in (Khamil, K.N.; Sabri, M.F.M.; Yusop, A.M.; Sharuddin, M.S., 2018)

While from MATLAB/Simulink’s analytical simulation, it estimates the output voltage is 1.6340 V. The disagreement between experimental and simulation at 0.45% is considered an excellent estimation.

CONCLUSION

In conclusion, the analytical modelling presented in this paper is an easy method to analyze the performance of the module parameters. The equations from the base-dependence are modelled into the Simulink block and graph representation of the output can be generated using several codes on MATLAB command window.

The results obtain agrees well with the datasheet provided from the manufacturer which proved the

modelling and the in-lab experimental values validated the numerical simulation as well. The modelling in MATLAB is a useful tool for the selection of suitable module for specific applications

#### ACKNOWLEDGEMENT

This project is supported by Ministry of Education Malaysia (MOE) (grant number: FRGS/1/2017/TK07/FKEKK-CETRI/F00337) and Universiti Teknikal Malaysia Melaka.

#### REFERENCES

- Adaptive Thermal Management. (2018). Technical Reference: Optimising Thermoelectric Cooler Modules in a System. <http://www.europanthermodynamics.com/images/uploads/Technical%20Documents/Optimising%20a%20thermoelectric%20cooler%20module%20in%20a%20system%20v2.pdf> [May 23, 2018]
- Bogue, R. (2015). Energy harvesting: a review of recent developments. *Sensor Review*, 35(1), 1-5.
- Bonisoli, E., Luc, D., Dr Guillaume Crevecoe, P., Di Monaco, F., Tornincasa, S., Freschi, F., . . . Repetto, M. (2014). Multi-physics optimisation of an energy harvester device for automotive application. *COMPEL - The international journal for computation and mathematics in electrical and electronic engineering*, 33(3), 846-855.
- Bonisoli, E., Manca, N., & Repetto, M. (2015). Multi-physics optimisation of energy harvesters. *COMPEL - The international journal for computation and mathematics in electrical and electronic engineering*, 34(5), 1392-1403.
- Favarel, C., Bédécarrats, J.-P., Kousksou, T., & Champier, D. (2015). Experimental analysis with numerical comparison for different thermoelectric generators configurations.
- i-SCOOP.eu. (2018). Energy efficiency as a core component of Industry 4.0. <https://www.i-scoop.eu/industry-4-0/energy-efficiency-industry-4-0/> [May 21, 2018]
- Ivaylo, B., Liliya, S., Anatoliy, A., & Pavlik, R. (2017). Mathematical Model of Thermoelectric Peltier Module. *Journal of Communication and Computer*, 14.
- J.Sampe, N.A.A. Semsudin, F.F.Zulkifli, & B.Y. Majlis. (2017). Micro Hybrid Energy Harvester Circuit for Biomedical Application. *Jurnal Kejuruteraan*, 29(1), 41-48.
- Khamil, K. N., Sabri, M. F. M., Yusop, A., M., & Sharuddin, M. S. (2018). An Evaluation of TEC and TEG Characterization for a Road Thermal Energy Harvesting. Paper presented at the IEEE 2018 International Conference on Sustainable Energy Engineering and Application (ICSEEA), Tangerang, Indonesia.
- Lineykin, S., & Ben-Yaakov, S. (2007). Modeling and analysis of thermoelectric modules. *IEEE Transactions on Industry Applications*.
- Mahidur R. Sarker\*, Azah. Mohamed, & Mohamed, R. (2016). Vibration Based Piezoelectric Energy Harvesting Utilizing Bridgeless Rectifier Circuit. *Jurnal Kejuruteraan*, 28, 87-94.
- Mitrani, D., Salazar, J., Turó, A., García, M. J., & Chávez, J. A. (2009). One-dimensional modeling of TE devices considering temperature-dependent parameters using SPICE. *Microelectronics Journal*, 40, 1398-1405.
- Morin, K. (September 12, 2017). EcoXperts get it: Critical power availability and reliability in Industry 4.0 <https://blog.schneider-electric.com/building-management/2017/09/12/ecoxperts-get-critical-power-availability-reliability-industry-4-0/> [May 21, 2018]
- Nesarajah, M., & Frey, G. (2016). Thermoelectric power generation: Peltier element versus thermoelectric generator. *IECON Proceedings (Industrial Electronics Conference)*, 4252-4257.
- Palacios, R., Arenas, A., Pecharrom??n, R. R., & Pagola, F. L. (2009). Analytical procedure to obtain internal parameters from performance curves of commercial thermoelectric modules. *Applied Thermal Engineering*, 29, 3501-3505.
- R. Mohamed, A. M. Yusop, A. Mohamed, & Nordin, N. I. (2016). Behavioral Analysis of Thermoelectric Module under Different Configurations and Temperature Gradient. *Jurnal Kejuruteraan*, 28, 19-27.
- Tang, G., Rabeek, S. M., & Arasu, M. A. (2017). Thermal design and temperature gradient analysis for a thermoelectric energy harvest device in off-shore and marine application. *Proceedings of the 2016 IEEE 18th Electronics Packaging Technology Conference, EPTC 2016*.
- Thermonamic. (2017). Thermonamic Module: TES1-05350. [www.thermonamic.com/tes1-05350-English.pdf](http://www.thermonamic.com/tes1-05350-English.pdf) [Feb 16, 2019]
- Thermonamic. (2017). Thermonamic Module: TEP1-1994-3.5. [www.thermonamic.com/tep1-1994-3.5-English.pdf](http://www.thermonamic.com/tep1-1994-3.5-English.pdf) [Feb 19, 2019]



- Twaha, S., Zhu, J., Yan, Y., & Li, B. (2016). A comprehensive review of thermoelectric technology: Materials, applications, modelling and performance improvement. *Renewable and Sustainable Energy Reviews*, 65, 698-726.
- Wu, C. (1996). Analysis of waste-heat thermoelectric power generators. *Applied Thermal Engineering*, 16, 63-69.
- Zafar, M., Naeem Awais, M., Asif, M., Razaq, A., & Amin, G. (2017). Fabrication and characterization of piezoelectric nanogenerator based on Al/ZnO/Au structure. *Microelectronics International*, 34(1), 35-39.