

We are IntechOpen, the world's leading publisher of Open Access books Built by scientists, for scientists

5,000

Open access books available

125,000

International authors and editors

140M

Downloads

Our authors are among the

154

Countries delivered to

TOP 1%

most cited scientists

12.2%

Contributors from top 500 universities



WEB OF SCIENCE™

Selection of our books indexed in the Book Citation Index
in Web of Science™ Core Collection (BKCI)

Interested in publishing with us?
Contact book.department@intechopen.com

Numbers displayed above are based on latest data collected.

For more information visit www.intechopen.com



Fields in Dispersive Media

Emeka Ikpeazu

Abstract

It is not just the case that matter affects the propagation of light—or more specifically electromagnetic (EM) radiation—it is also the case that light affects the matter through which it propagates. Conversely, this affects the propagation of light through the medium, but in a much more specific way; this effect is a function of the properties of both the material and the incident EM radiation. We will additionally discuss the effects of dispersion in confined (bounded) media, i.e., where the dispersion is a function of the arrangement of certain materials and unbounded media where EM radiation is free to propagate undisturbed. This will be important when we discuss the propagation electric field signals of such media as well.

Keywords: refraction, materials, dispersion, electromagnetics, wave propagation, fiber optics

1. Introduction

Incident electromagnetic (EM) radiation excites the molecules in a material, and these molecules become polarized; they respond according to the direction of the electric field. **Figure 1** shows the initial step of the process of material polarization.

It should be adequately noted that there are *several* ways that material response to light-matter interaction can be analyzed. For the purposes of relevance, this chapter will analyze the mechanical response of the atom—as illustrated in **Figure 2**—in response to incident EM radiation waves.

In this chapter we will discuss polarization at the level of the interacting material, the effects of dispersion on a train of pulses, various types of polarization, and methods for reducing polarization to maintain the integrity of optical signals. But first, some words on non-dispersion in unbounded media, a more general term for what would normally be called “free space.”

Unbounded media are the baseline of understanding EM wave propagation. In unbounded media, waves are free to propagate unperturbed. Examples of unbounded media include the ocean, the air, and outer space. An unbounded medium would be the ideal location for an isotropic antenna as the radiation would be free to propagate in all directions, only weakening in accordance with the inverse square law. Such is ideal for radio towers which produce low-frequency EM waves which can propagate for kilometers and reach many people.

Additionally, unbounded media are generally non-dispersive. This is to say that the speed of energy propagation is orthogonal to the frequency of the said propagating energy. In the previous paragraph, it was said the waves in unbounded media

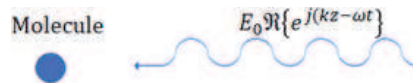

Figure 1.
An EM traveling wave is incident on a molecule of a particular material. This induces a unique response in molecules of the material.



Figure 2.
The mechanical response of the material to incoming monochromatic EM radiation. The vibrational response of the molecule is a function of its properties. This same principle is also related to the color of the flame that a molecule produces [1].

are free to propagate unperturbed. This is not *completely* true. Natural disturbances *within* the air or sea can interfere with the propagation of energy therein. However, these natural impediments are not necessarily treated as features of the media itself. It is for this reason that direct or *line-of-sight* propagation is key in facilitating communication between antennas and cell towers.

2. Understanding dispersion

Dispersion can be difficult to understand. There are picture balls on two parallel infinite conveyor belts running at different speeds, Belt A at the top and Belt B at the bottom. The conveyor belts in **Figure 3** carry balls at 2.5 cm/s and 3.0 cm/s, respectively. Additionally, the centers of the balls on each belt are separated by 10 cm and 12.5 cm, respectively. At time $t = 0$, the centers of Red Ball 0 (RB₀) and Blue Ball 0 (BB₀) are aligned. However, the center of BB₋₁ trails that of RB₋₁ by a distance of 2.5 cm.

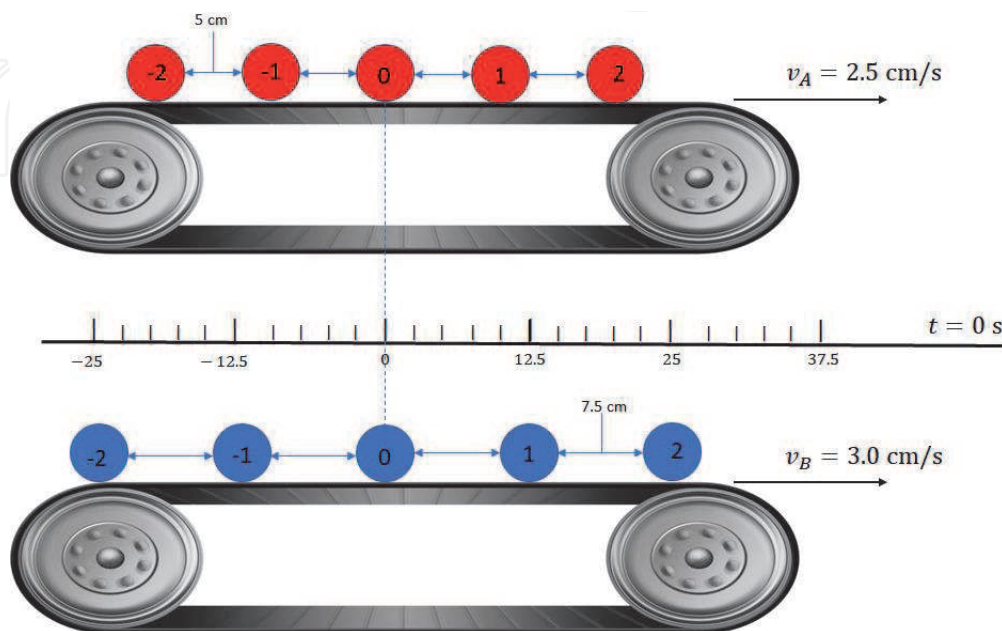

Figure 3.
A mechanical kinematic illustration of the principle of the dispersion.

Since Belt B is traveling faster than Belt A, the distance between BB_{-1} and RB_{-1} will decrease. From the perspective of Belt A, Belt B is moving with a velocity of 0.5 cm/s. At time $t = 5$, the center of BB_{-1} is aligned with that of RB_{-1} ; however, in that time the balls on Belt B have moved a net 15 cm, while those on Belt A have moved a net 12.5 cm. However, if one were to see the conveyor belts as a group, the belts would appear to have moved 2.5 cm (measuring from location of alignment) within that time, giving the conveyor belts a “group velocity” of 0.5 m/s even though the individual components are moving faster.

The situation described is analogous to the behavior of a wave propagating in free space. As the individual waves travel with their respective phase velocities along the guide, the two peaks become disaligned for a period [2]. Because the center of RB_{-1} will have traveled a distance $\lambda_{RB} + \Delta z$ with a phase velocity $v_{z, RB}$ and the center of BB_{-1} will have traveled a distance $\lambda_{BB} + \Delta z$ with phase velocity $v_{z, BB}$, one can then write a set of equations as

$$\lambda_{RB} + \Delta z = v_{z, RB} \Delta t \quad (1)$$

$$\lambda_{BB} + \Delta z = v_{z, BB} \Delta t \quad (2)$$

We can then write Δt as

$$\Delta t = \frac{\lambda_{RB} - \lambda_{BB}}{v_{z, RB} - v_{z, BB}} \quad (3)$$

In the same way, one can express Δz as

$$\Delta z = \frac{\lambda_{RB} v_{z, BB} - \lambda_{BB} v_{z, RB}}{v_{z, RB} - v_{z, BB}} \quad (4)$$

Finally, one can express the group velocity as

$$\begin{aligned} \frac{\Delta z}{\Delta t} = v_z &= \frac{\lambda_{RB} v_{z, BB} - \lambda_{BB} v_{z, RB}}{\lambda_{RB} - \lambda_{BB}} = \frac{\lambda_{RB} \lambda_{BB} f_{BB} - \lambda_{BB} \lambda_{RB} f_{RB}}{\lambda_{RB} - \lambda_{BB}} \quad (5) \\ &= \frac{\lambda_{BB} \lambda_{RB} (f_{BB} - f_{RB})}{\lambda_{RB} - \lambda_{BB}} = \frac{f_{BB} - f_{RB}}{\frac{1}{\lambda_{BB}} - \frac{1}{\lambda_{RB}}} \rightarrow \frac{\omega_{BB} - \omega_{RB}}{2\pi \left(\frac{1}{\lambda_{BB}} - \frac{1}{\lambda_{RB}} \right)} \end{aligned}$$

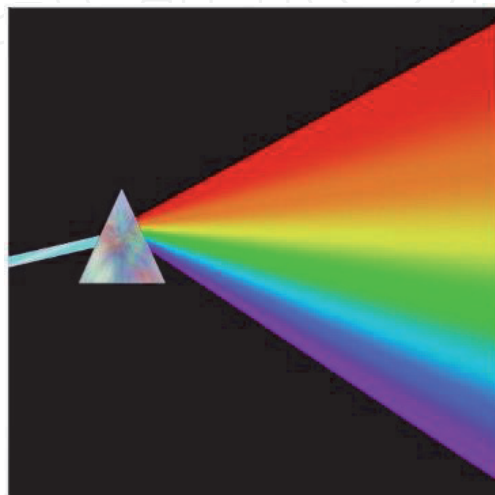

Figure 4.
 The separation of white light into different colors by prismatic dispersion.

We know that the wavevector $k = 2\pi/\lambda$, so one express the group velocity as

$$v_g = \frac{d\omega}{dk} \quad (6)$$

This is to say the group velocity is the degree change in the temporal frequency for every change in the spatial frequency. What this means is that the value of the frequency is on some level a function of the k -vector and ultimately a function of the wavelength. As illustrated in **Figure 4**, this has implications for the propagation of light through various media as different wavelengths will travel at different velocities and take various pathways therein [3].

3. Plasmonic dispersion

The Lorentz force is the force on a point charge due to EM fields. As discussed in the Introduction, EM radiation causes motion among the particles in a material as shown in **Figure 2**. The direction (vector) of this force is called the polarization. Assuming a sea of free particles in vacuum [4], the strength of the Lorentz force on a point charge is expressed as

$$\vec{F} = q(\vec{E} + \vec{v} \times \vec{B}), \quad (7)$$

where \vec{F} , q , \vec{E} , \vec{v} , and \vec{B} are the force, the charge, the electric field strength, the particle velocity, and the magnetic flux density, respectively. For our purposes, we consider an isotropic material where the electric permittivity is a simple scalar ϵ . This means that the Lorentz force vector will be unidirectional. In birefringent and anisotropic, the permittivity would be expressed as a tensor, and the Lorentz force vector would be multidirectional.

We additionally assume a dielectric unmagnetized material such that the value of \vec{B} is assumed to be zero. This makes the response of the atoms into a simple harmonic oscillator. In this case we can express the Lorentz force as simply

$$\vec{F} = q\vec{E} = m\vec{a} = m\left(\frac{d^2\vec{d}}{dt^2}\right) = m(j\omega)^2\vec{d} = -m\omega^2\vec{d}, \quad (8)$$

where m , ω , and \vec{d} are the mass, the angular frequency, and dipole vector, respectively. We can simplify to get the dipole vector as

$$\vec{d} = -\frac{q\vec{E}}{m\omega^2} \rightarrow \vec{P} = Nq\vec{d} = -\frac{Nq^2\vec{E}}{m\omega^2}, \quad (9)$$

where \vec{P} is the polarization vector and N is the dipole density. The electric displacement field \vec{D} is the permittivity ϵ multiplied by the electric field \vec{E} , but in dielectric materials, the electric field induces a response in the material known as the polarization. This effect is added to the original displacement field to make it so that

$$\vec{D} = \epsilon_0\vec{E} + \vec{P} = \left(\epsilon_0 - \frac{Nq^2}{m\omega^2}\right)\vec{E} \quad (10)$$

As a result, the *effective* permittivity is expressed in (11) as

$$\epsilon = \epsilon_0 \left(1 - \frac{Nq^2}{\epsilon_0 m \omega^2} \right) = \epsilon_0 \left(1 - \frac{\omega_p^2}{\omega^2} \right), \quad (11)$$

where the plasma frequency $\omega_p = q \sqrt{N/\epsilon_0 m}$.

The plasma frequency is the natural oscillation frequency of the displaced electrons in a neutral plasma [4, 5] of free electrons where it is assumed that collisions are rare. Altogether we can express the dispersion relation thusly

$$k^2 = \omega^2 \epsilon \mu = \epsilon_0 \mu_0 (\omega^2 - \omega_p^2) \rightarrow \omega(k) = \sqrt{k^2 c^2 + \omega_p^2} \quad (12)$$

This means that the group velocity is expressed as

$$v_g = \frac{kc^2}{\sqrt{k^2 c^2 + \omega_p^2}} = c \sqrt{1 - \left(\frac{\omega_p^2}{\omega^2} \right)} \quad (13)$$

In a material like germanium (Ge) the intrinsic carrier density N_{Ge} is $2.5 \times 10^{19} \text{ m}^{-3}$ [6]; the rest of the variables are known constants. This gives germanium a plasma frequency of $f_{p,\text{Ge}} = 44.8 \text{ GHz}$. We apply the relation in (13) to germanium to measure the frequency-dependent group velocity of light therein as demonstrated in **Figure 5**.

Below the plasma frequency, the value of the k -vector becomes purely imaginary, meaning that the electric field is purely evanescent—and non-propagating—at that point. The group velocity is the slope of the dispersion curve in **Figure 6**. For both curves, the lowest allowable frequency is the plasma frequency. Below this frequency, the permittivity is negative, the k -vector is imaginary, and,

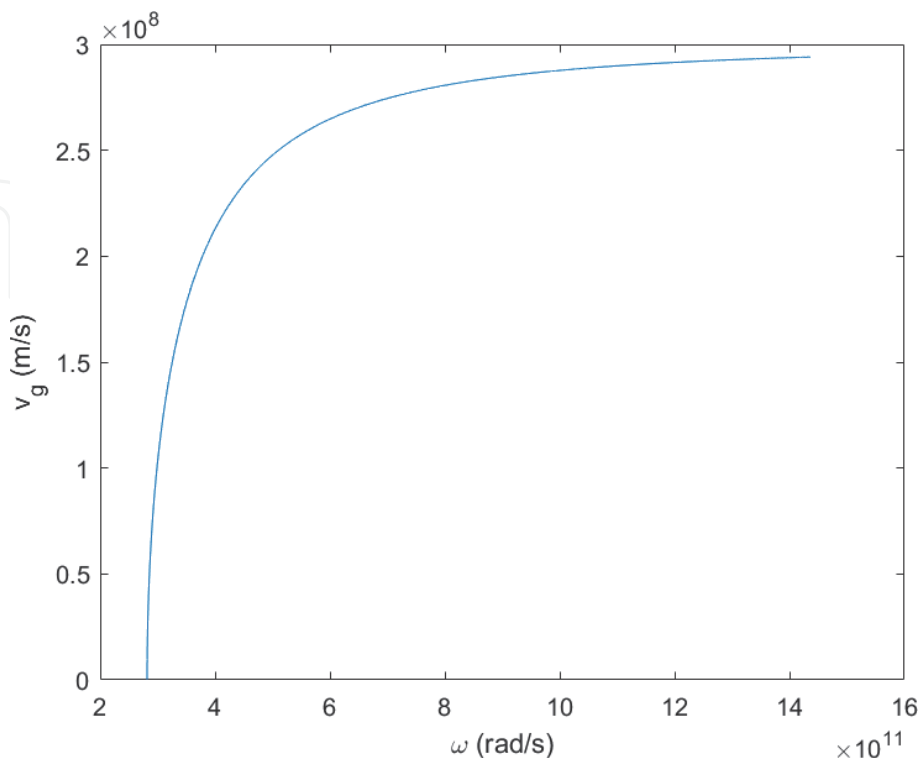

Figure 5.
The group velocity of light through germanium as a function of frequency.

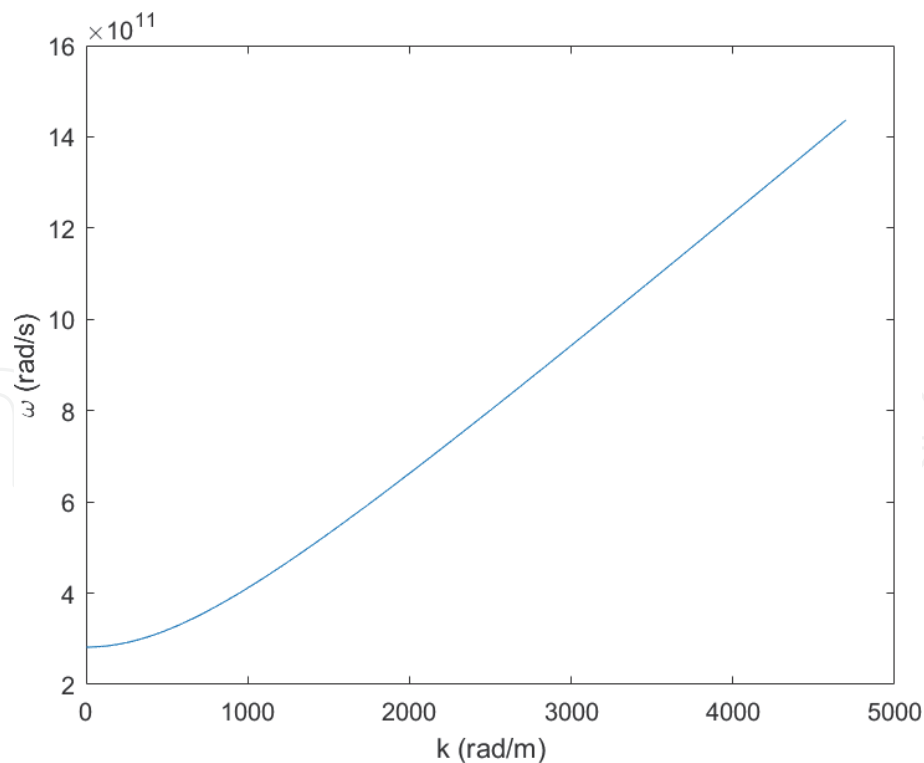

Figure 6.
The dispersion relation for germanium where ω is function of k .

consequently, the field simply evanesces into the material and propagation completely ceases.

4. Dispersion in conductive media

In the previous section, we derived plasmonic dispersion from understanding the Lorentz force law as it pertains to electrons in a dielectric material. Dispersion can also occur in a conducting material where the charges therein are unbound. When we apply our knowledge of electromagnetics and electrostatics to a conductor, we discover a few things:

1. There is zero net charge within a conductor, although charges can still randomly move around therein as seen in **Figure 7**.
2. All the charge rests on the surface of the conductor, perpendicular to the surface.
3. The presence of an electric field induces the motion of electrons, creating a conduction current [7].

Additionally, in a conductor the free charges are always pushed to the surface so that electrostatic equilibrium is maintained. This means that the gradient of the electric field $\vec{\nabla} \cdot \vec{E}$ equals zero. Things are different in the presence of an electric field, e.g., **Figure 8**, where the electrons are pulled in the opposite direction of the electric field.

With regard to conductive media, we can do the same thing through an understanding and application of Faraday's law which states that a time-varying magnetic flux density *always* accompanies a nonconservative electric field, i.e., a field \vec{E} for which $\vec{\nabla} \times \vec{E} = \mathbf{0}$. This is demonstrated by the equation

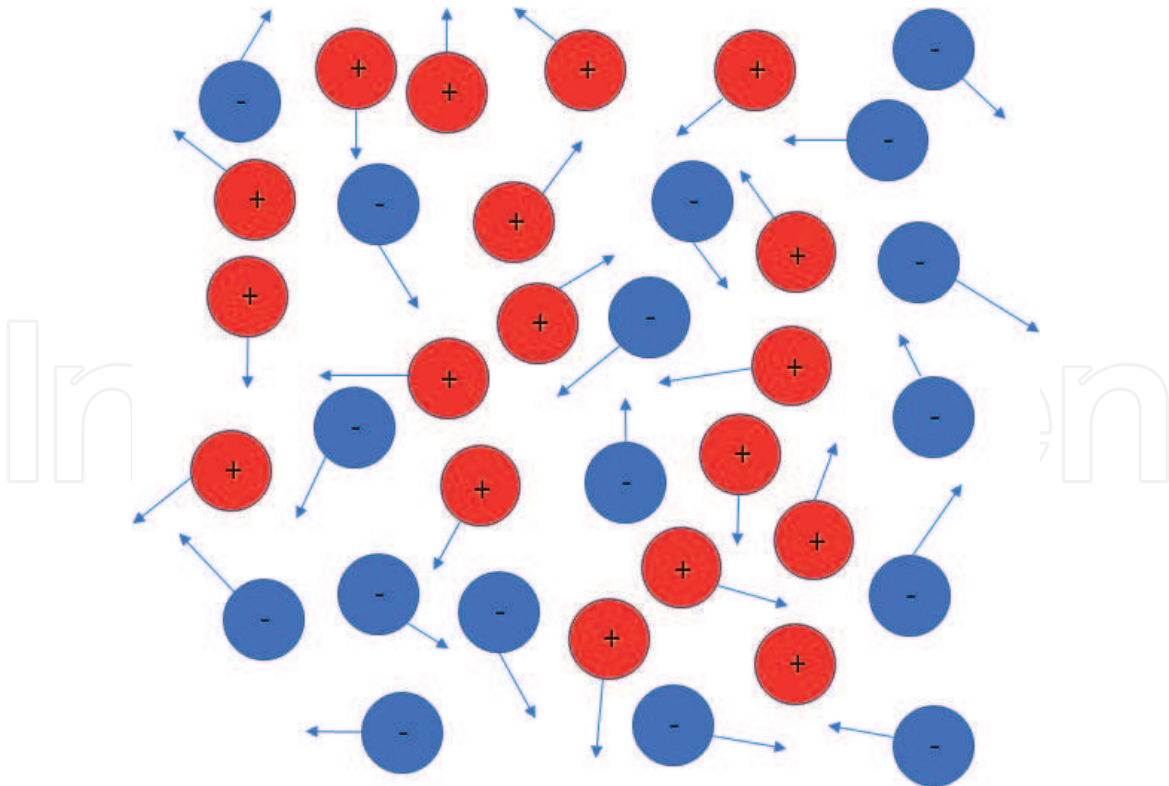

Figure 7.
 The distribution of freely moving protons (red) and electrons (blue) in a conductive material in electrostatic equilibrium where $Q_{\Sigma} = 0$.

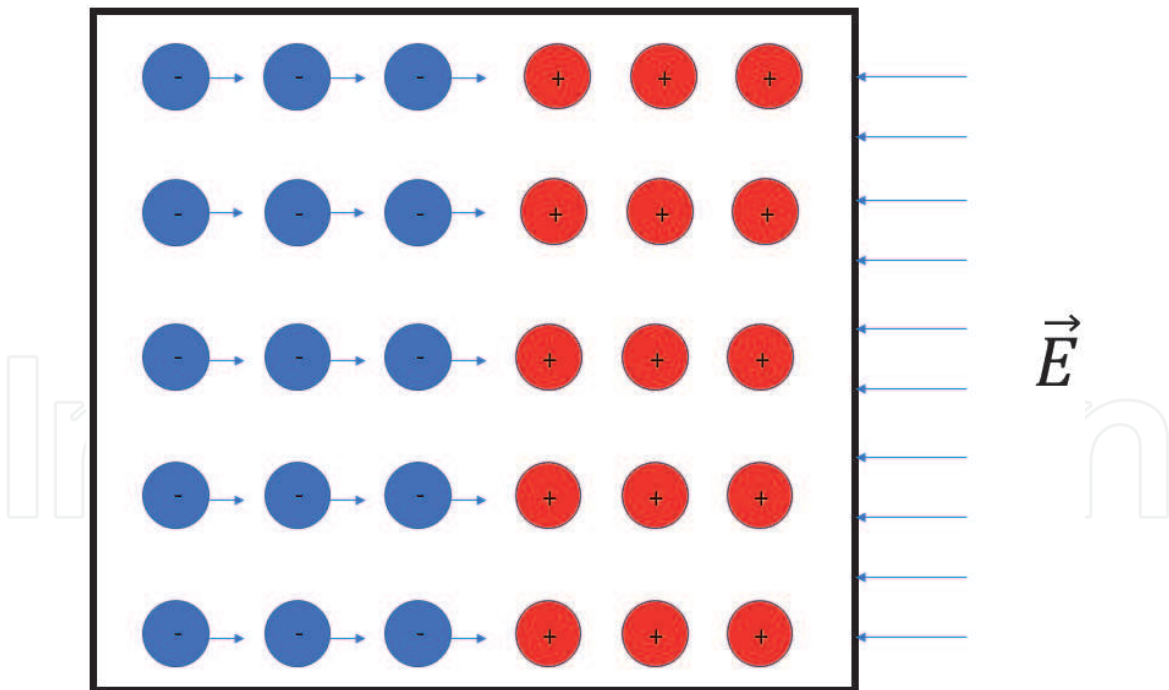

Figure 8.
 The kinetic behavior of electrons in the presence of an electric field produces a steady-state current known as the conduction current.

$$\vec{\nabla} \times \vec{E} = -\frac{\partial \vec{B}}{\partial t} = -\mu_0 \frac{\partial \vec{H}}{\partial t} \quad (14)$$

We can combine this with Ampère's law where the curl of the magnetic field generates a time-varying electric field such that

$$\vec{\nabla} \times \vec{H} = \vec{J}_f + \epsilon \frac{\partial \vec{E}}{\partial t} = \sigma \vec{E} + \frac{\partial \vec{E}}{\partial t} = (\sigma + j\omega\epsilon) \vec{E} = j\omega\epsilon_{eff} \vec{E}, \quad (15)$$

where \vec{J}_f is the free current density vector produced in the presence of an electric field as exemplified in **Figure 8** and σ is the conductivity. We can calculate the effective permittivity this way such that $\epsilon_{eff} = \epsilon \left(1 - \frac{j\sigma}{\omega\epsilon}\right)$. In this way we can write the dispersion relation.

$$\begin{aligned} k &= \omega \sqrt{\mu_0 \epsilon_{eff}(\omega)} = \omega \sqrt{\frac{\mu_0 \epsilon}{\epsilon_0}} \sqrt{1 - \frac{j\sigma}{\omega\epsilon}} = \sqrt{\frac{\mu_0 \epsilon}{\epsilon_0}} \sqrt{\omega^2 - \frac{j\sigma\omega}{\epsilon}} \\ &= \sqrt{\frac{\mu_0 \epsilon}{\epsilon_0}} \sqrt{\omega^4 + \left(\frac{\sigma^2 \omega^2}{\epsilon^2}\right)} e^{-i \left(\frac{\tan^{-1}(\frac{\sigma}{\epsilon\omega})}{2}\right)} \end{aligned} \quad (16)$$

This wavenumber k is also complex where $k = k' - jk''$, where

$$\begin{aligned} k' &= \sqrt{\frac{\mu_0 \epsilon}{\epsilon_0}} \sqrt{\omega^4 + \left(\frac{\sigma^2 \omega^2}{\epsilon^2}\right)} \cos\left(\frac{\tan^{-1} \frac{\sigma}{\epsilon\omega}}{2}\right) \leftrightarrow \\ k'' &= \sqrt{\frac{\mu_0 \epsilon}{\epsilon_0}} \sqrt{\omega^4 + \left(\frac{\sigma^2 \omega^2}{\epsilon^2}\right)} \sin\left(\frac{\tan^{-1} \frac{\sigma}{\epsilon\omega}}{2}\right). \end{aligned} \quad (17)$$

The real part of the wavenumber k' represents wavenumber inside the material and the imaginary part k'' represents the attenuation coefficient inside the material.

$$\begin{aligned} v_g &= \left(\frac{dk'}{d\omega}\right)^{-1} \\ &= \sqrt{\frac{\epsilon_0}{\mu_0 \epsilon}} \left\{ \frac{\left(\frac{\sigma^2}{\epsilon^2} + 2\omega^2\right) \cos\left(\frac{\tan^{-1} \frac{\sigma}{\epsilon\omega}}{2}\right)}{2\omega \left(\frac{\sigma^2}{\epsilon_0} + \omega^2\right)} + \frac{\frac{\sigma}{\epsilon} \sqrt{\omega^4 + \left(\frac{\sigma^2 \omega^2}{\epsilon^2}\right)}}{\left(\omega^2 + \frac{\sigma^2}{\epsilon^2}\right)} \sin\left(\frac{\tan^{-1} \frac{\sigma}{\epsilon\omega}}{2}\right) \right\}^{-1} \\ &= \frac{2\sqrt{\frac{\epsilon_0}{\mu_0 \epsilon}} \left(\omega^2 + \frac{\sigma^2}{\epsilon^2}\right)}{\left(\frac{\sigma^2}{\epsilon^2 \omega} + 2\omega\right) \cos\left(\frac{\tan^{-1} \frac{\sigma}{\epsilon\omega}}{2}\right) + \frac{\sigma}{\epsilon} \sqrt{\omega^4 + \left(\frac{\sigma^2 \omega^2}{\epsilon^2}\right)} \sin\left(\frac{\tan^{-1} \frac{\sigma}{\epsilon\omega}}{2}\right)} \end{aligned} \quad (18)$$

Of course, there are various conditions that could simplify Eq. (16). The $\sigma/\omega\epsilon$ component in (15) is known as the dielectric *loss tangent* $\tan \delta$ [8]. This figure δ describes a materials inherent ability to dissipate electromagnetic energy within it. For example, a material with a high conductivity will absorb—dissipate—EM radiation more quickly. Such a material has would have a high loss tangent compared to a good dielectric.

We can express the dielectric relaxation time τ_d as ϵ/σ . In cases that $\delta \ll 1$ or $\tau_d^{-1} \ll \omega$ —as would be the case in a lossy dielectric—we can approximate the permittivity as $\epsilon_{eff} \approx 1 - \frac{j\sigma}{2\omega\epsilon}$ using the binomial expansion theorem. The material behaves like a standard dielectric as $v_g = c/n$, where n is the index of refraction, and $k'' = \sigma\eta/2$, where η is the impedance of the material $\sqrt{\mu_0/\epsilon}$.

In cases where $1 \ll \delta$ or $\omega \ll \tau_d^{-1}$, the case of a good conductor, $k \approx \sqrt{\sigma\mu_0\omega/2}(1-j)$ and $v_g \approx \sqrt{8\omega/\sigma\mu_0}$. In the latter case, the field penetrates only slightly into the material as $\mathcal{O}(k') = \mathcal{O}(k'')$.

$$\frac{2\sqrt{\frac{\epsilon_0}{\mu_0\epsilon}}\left(\omega^2 + \frac{\sigma^2}{\epsilon^2}\right)}{\left(\frac{\sigma^2}{\epsilon^2\omega} + 2\omega\right) \cos\left(\frac{\tan^{-1}\frac{\sigma}{\epsilon\omega}}{2}\right) + \frac{\sigma}{\epsilon} \sqrt{\omega^4 + \left(\frac{\sigma^2\omega^2}{\epsilon^2}\right)} \sin\left(\frac{\tan^{-1}\frac{\sigma}{\epsilon\omega}}{2}\right)} \quad (19)$$

Additionally, the attenuation is a new phenomenon resulting from the fact that the k -vector is complex. When we take the reciprocal of this coefficient get another quantity known as the *skin depth* or penetration depth δ_p , the extent to which the field penetrates the material. In a good conductor, δ_p takes a value $\sqrt{2/\sigma\mu_0\omega}$. The values of ϵ and σ are listed in **Table 1** for some good conductors [9].

Good conductors are characterized by an abundance of free electrons. Good conductors (good dielectrics), on the other hand, are characterized by a paucity of such electrons. Examples of good dielectrics are enumerated in **Table 2** [10].

Figure 9 shows the interaction between an electric field and an good conductor (e.g., gold) at a wavelength of 1.55 μ m. The field decays very rapidly as gold has a skin depth of 5.66 nm and a dielectric relaxation time of 1.49 attoseconds (10^{-18} s) at this wavelength. This contrasts with a lossy dielectric where the skin depth is much larger, and there is thus more field penetration as displayed in **Figure 10** with germanium where the skin depth is roughly a centimeter and the dielectric relaxation time is 66.1 picoseconds.

Conductive media have more free electrons that *move* in the presence of an electric field than those that simply vibrate. Conductive media produce a loss (attenuation) component in propagation of incoming EM radiation. Additionally, the drift movement of electrons in conductive media causes heat to which the electrical energy from the incoming field is transferred. This energy conversion causes the dissipation of the field. Nevertheless, in the context of the phenomenon of dispersion, the degree of this attenuation is a function of the frequency of the incoming EM radiation.

Material	Conductivity (S/m) @ $T = 293$ K
Silver	6.1×10^7
Copper	5.8×10^7
Gold	4.1×10^7
Aluminum	3.5×10^7
Brass	1.5×10^7

Table 1.
 Conductivities of some good conductors.

Material	Permittivity (F/m)
Calcium	2.685×10^{-11}
Marble	7.08×10^{-11}
Silicon dioxide (SiO ₂)	3.452×10^{-11}
Slate	3.54×10^{-11}
Polytetrafluoroethylene (PTFE)	1.77×10^{-11}

Table 2.
 Conductivities of some good dielectrics.

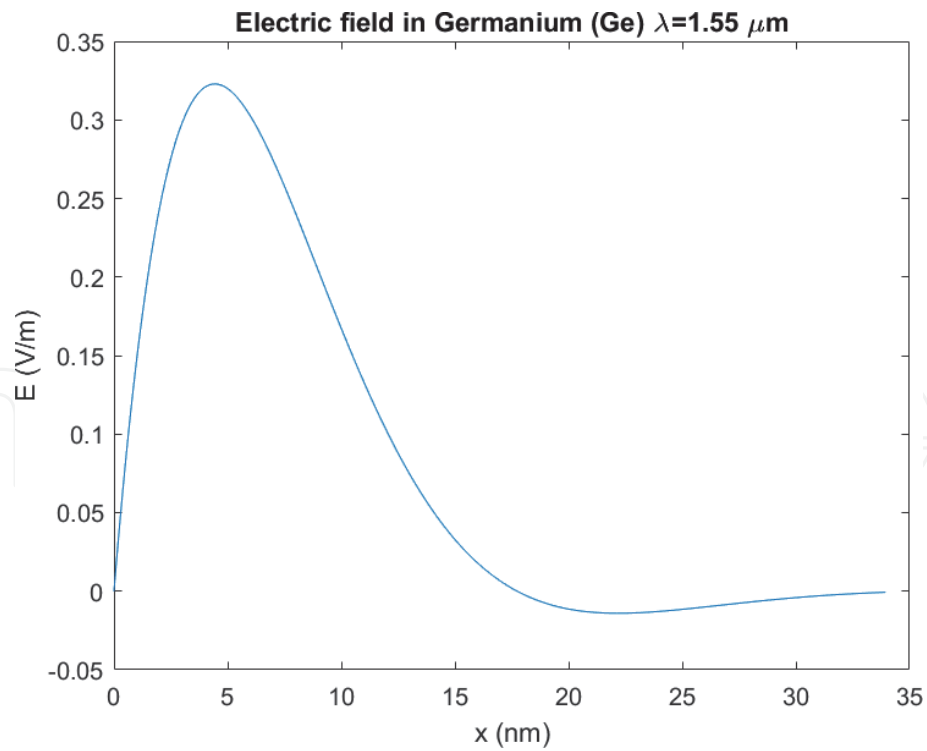

Figure 9.
The rapid decay of an electric field upon impact interaction with gold.

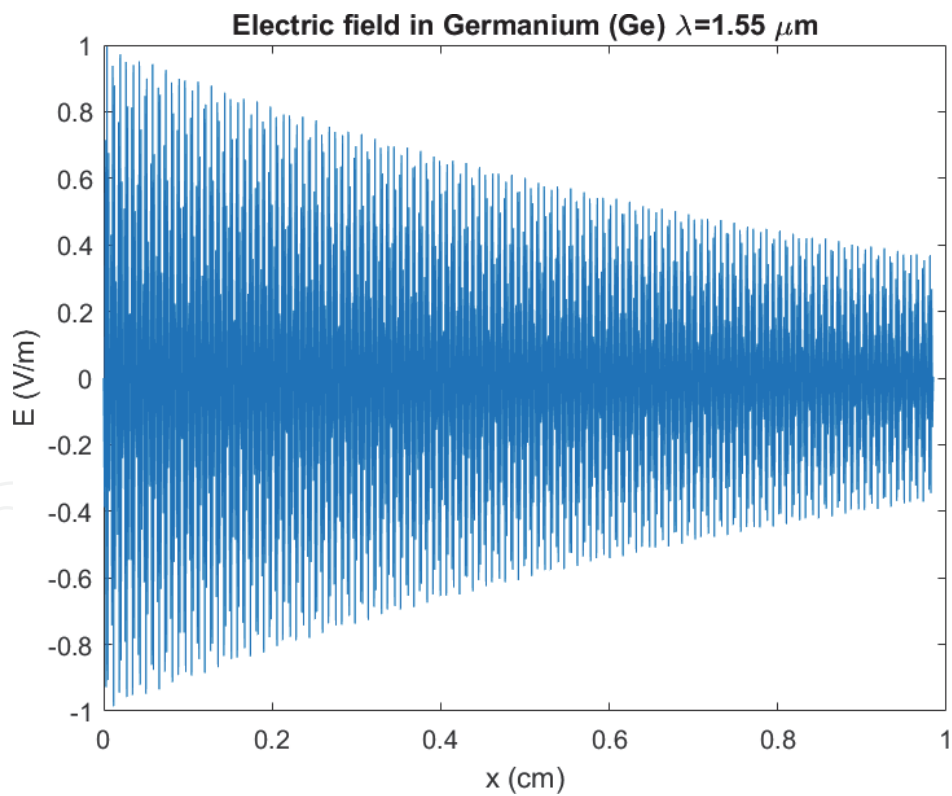

Figure 10.
The comparatively slow decay of an electric field upon impact interaction with germanium.

5. Modal dispersion

So far, this chapter has covered the form that dispersion takes in media (i.e., material dispersion). However, there are other types of dispersion that exist which ultimately stem from the properties of the material. One of these other ways is

modal dispersion [11]. This is when the velocity of various modes changes as a function of the input wavelength. As displayed in **Figure 11**, the different modes that propagate at different group velocities and angles, which themselves are functions of an input wavelength. These modes that arise in a waveguide are the different forms that the electric field can take in a geometrically confined structure. These forms are functions of satisfying the Helmholtz equation for the geometry of the confining structure. Only a finite number of fields do this and produce the appropriate wavevector in the z -direction, β . Consequently, only a finite number of modes will be allowed in the structure.

The angle at which certain modes propagate within makes a difference as to the speed of propagation because shallower angles have less deviation from the center equilibrium as shown in **Figure 12**.

In a rectangular waveguide, the total distance a mode must travel is expressed as

$$L = \frac{L}{\cos \theta_x \cos \theta_y} \quad (20)$$

where θ_x and θ_y are the angles of deviation in the x - and y -directions, respectively. The higher the order of the mode, the steeper the angle of the travel, and the more distance the mode must traverse through the waveguide. In **Figure 13**, the same principle holds true in an optical fiber. The rays of the fundamental modes (TM and TE) take a meridional form (a) passing through origin as they propagate and the hybrid modes—HE and EH—spiral in a helical form taking a twisted path through the fiber.

Additionally, modes that have a shallower angle of interaction with the core-cladding boundary will have higher group velocities. A higher-order mode has a

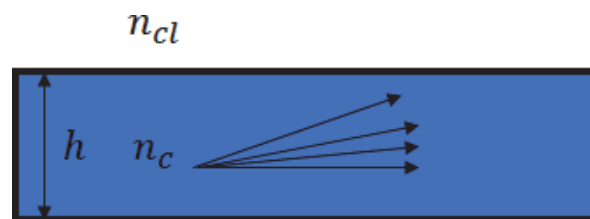

Figure 11. The various modes within a step-index waveguide—where h , n_c , and n_{cl} are the height and the core and cladding indices, respectively.

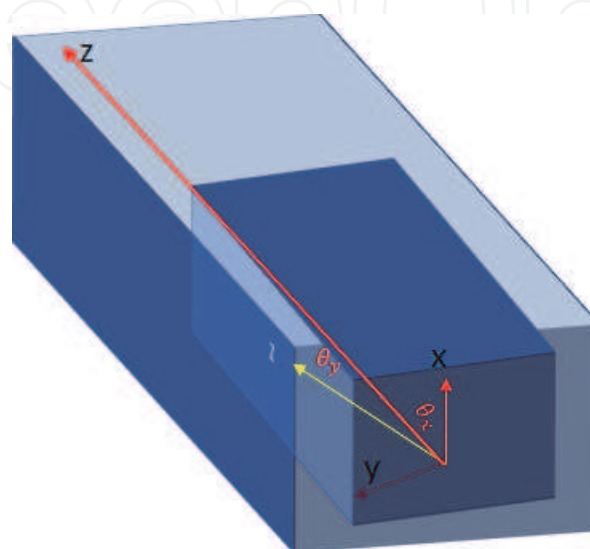

Figure 12. A mode in a rectangular waveguide propagates in the x - and y -directions at various angles.

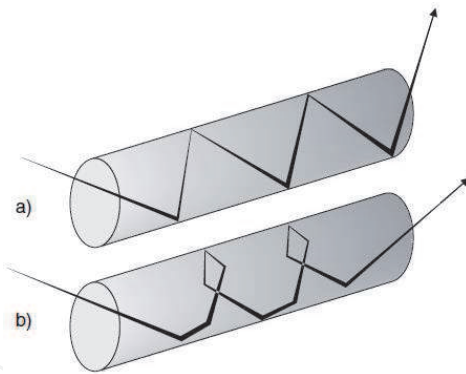

Figure 13.
Rays taking meridional (a) and helical (b) forms in an optical fiber [12].

lower β value as its k -vectors in other directions are higher, leading to steeper interaction angles with the core-cladding boundary.

The way that the modes propagate through the fiber at different velocities makes the waveguide an effective multipath propagation channel where the received signal is a sum of the various scaled “echoes” of the original signal carried by the various modes that propagate therein.

As a result, this dispersion distorts the pulse and corrupts the information. As shown in **Figures 14** and **15**, the pulses deform from their respective Gaussian and rectangular forms as a result of the different path delays, a phenomenon known as *delay distortion* [13]. Calculation of modal delays is used in order to set various bit rates for optical pulses.

One way to ameliorate modal (intermodal) dispersion is to use a single-mode waveguide where the only one mode is carried through. Another way is to make use of waveguides with a parabolic index of refraction, producing a quasi-sinusoidal pathway through the waveguide as demonstrated in **Figure 16**.

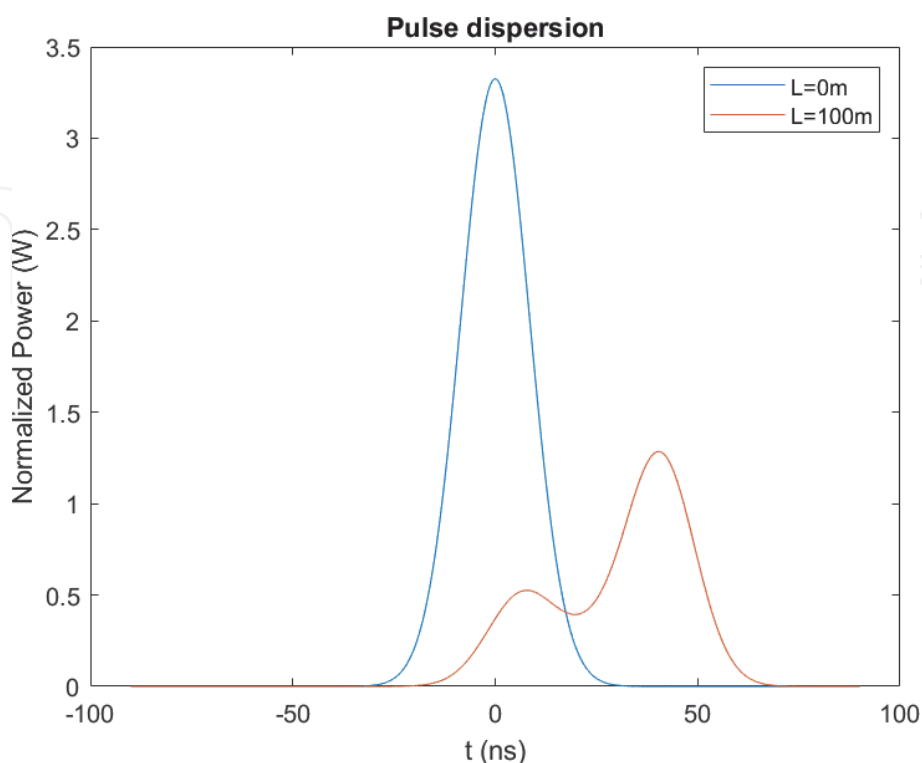

Figure 14.
The intermodally dispersive time evolution of a Gaussian optical pulse in a multimode rectangular waveguide.

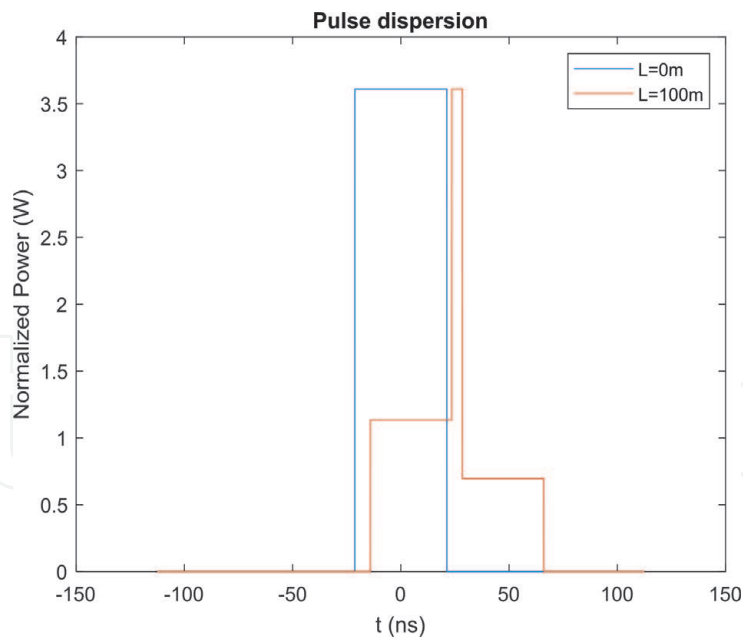

Figure 15.
 The intermodally dispersive time evolution of the more commonly used rectangular pulse in a multimode rectangular waveguide.

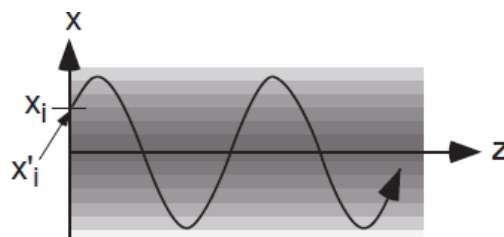

Figure 16.
 The pathway through the waveguide is sinusoidal [14] as it is bound to its axis.

The ray switches paths as it passes the region of highest index, meaning that it spends less of its time in the region of lowest index. This is to say that the phase velocity of the wave changes within the waveguide. From a ray optics perspective, the crest of the wave has a position-varying velocity, effectively making continuous switches through “different materials.”

The dispersion characteristic for graded-index (GRIN) waveguides is quite different as well. **Figure 17** shows that higher wavelengths are correlated with less dispersion for GRIN waveguides. The step-index, on the other hand, maintains a positive wavelength dispersion characteristic.

It should be noted that modal dispersion is more of a function of the *arrangement* of media, not the sole medium itself. Changes in size, cladding material, and wavelength can affect the propagation of light therein.

6. Chromatic dispersion

Changes in wavelength are important in understanding how light will propagate. As shown in **Figure 18**, the way these β values vary with the wavelength produces various group velocities for different modes. The higher-order modes have a lower group velocity as they travel. The index of the fused silica core in the waveguide

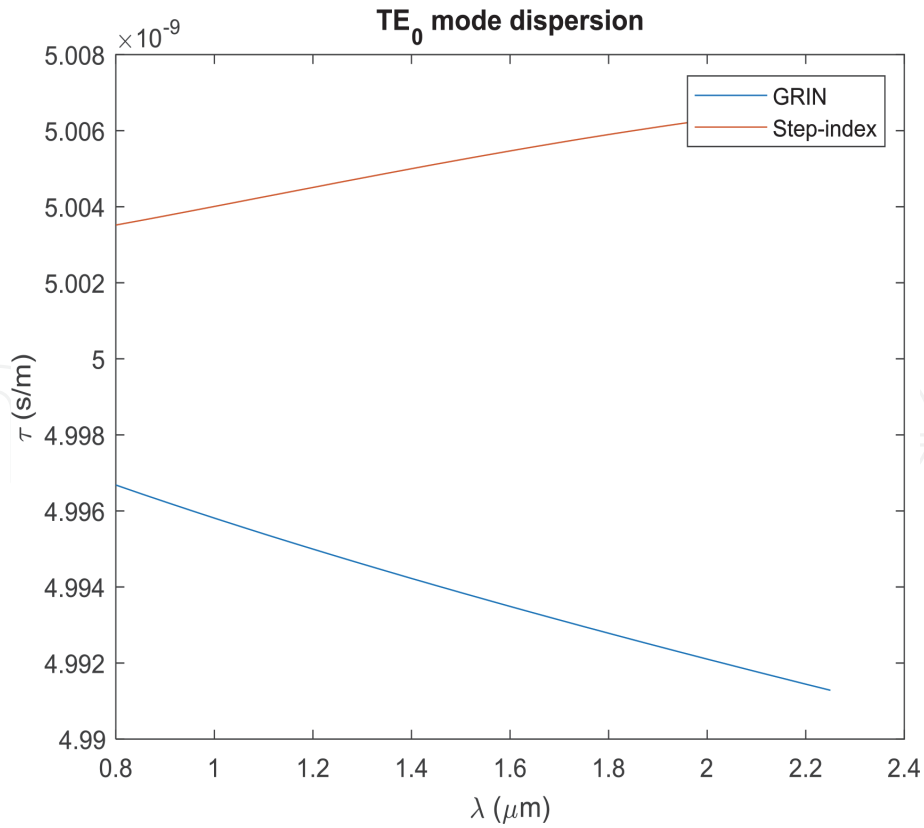

Figure 17. The fundamental mode (TE_0) dispersion characteristic of GRIN slab waveguide vs. that of a step-index slab waveguide.

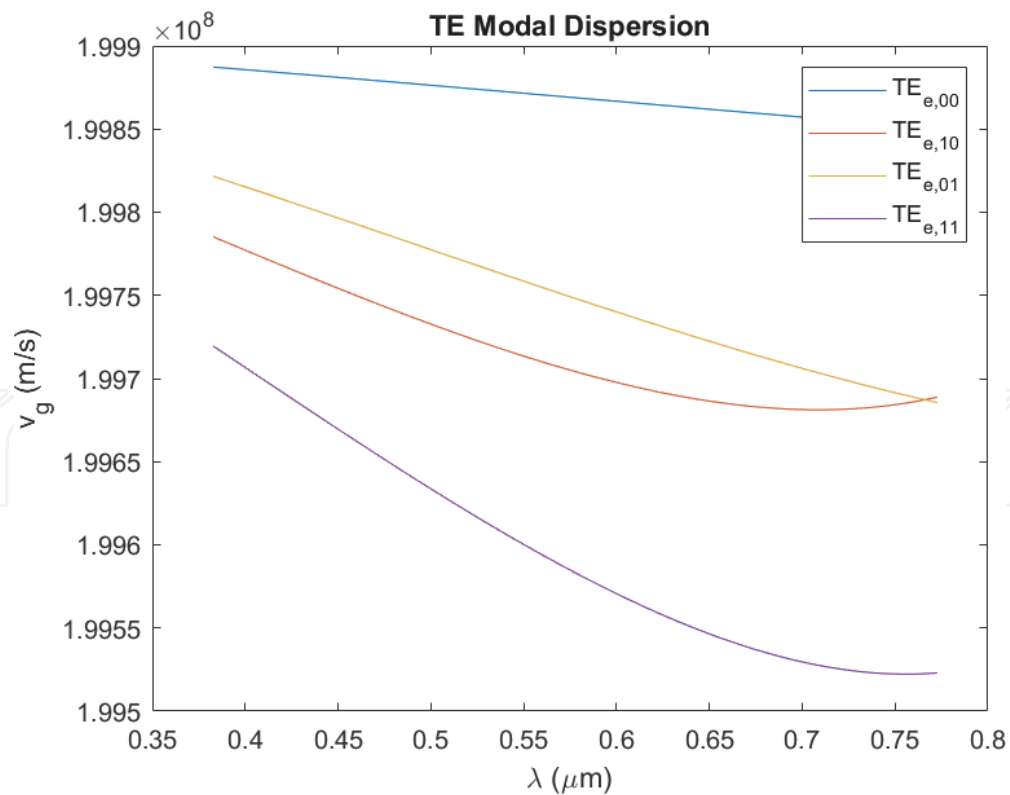

Figure 18. The group velocities of the transverse electric (TE) modes in a fused silica rectangular waveguide as a function of the wavelengths in the visible spectrum.

described in **Figure 18** is 1.5, meaning that light will travel roughly 2×10^8 m/s therein. However, the contribution from dispersion increases the *effective index* n_{eff} “experienced” by each mode at a particular wavelength.

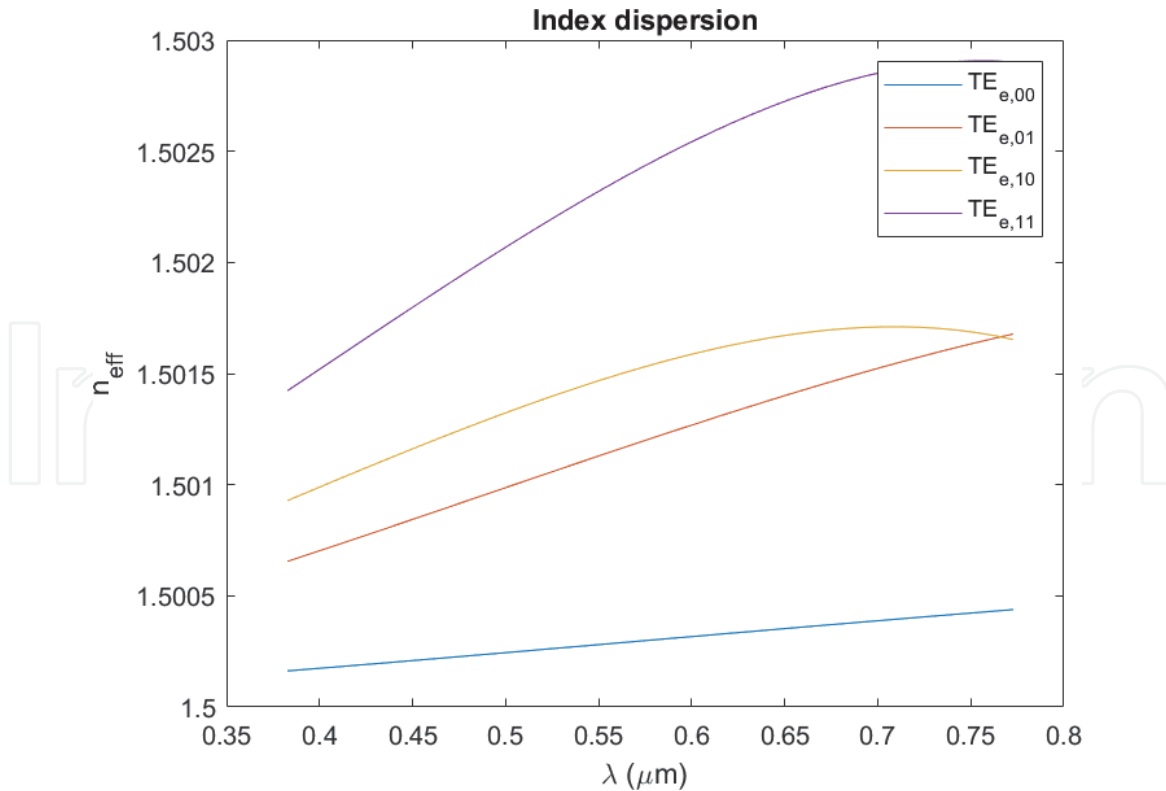

Figure 19.
 Dispersion creates a higher refractive index for the modes as λ increases.

The plot in **Figure 18** can be reconfigured to show that each mode has an effective index of refraction in the core that varies with its wavelength. This means that different “colors” of light will have different refractive indices in the waveguide. **Figure 19** shows that as λ increases, the group velocity decreases.

Figure 19 shows that there is an added index of refraction that comes from the dispersion that contributes the delay of the modes; this is also known as the group index N_g .

7. Intramodal dispersion

Dispersion can occur even in the context of a single-mode waveguide (of whatever geometry). In the previous section, we demonstrated a difference in n_{eff} as it pertains to various wavelengths stimulating a particular mode. However, we can observe a similar phenomenon in a single-mode fiber.

In the Introduction, we discussed how one can model the plasmonic impulse response of a material in the presence of an electric field as a mechanical system for which

$$\vec{x}(t) = \frac{-e/m}{(\omega^2 - \omega_0^2) + j\gamma\omega} E_0 e^{j\omega t}, \quad (21)$$

where E_0 , ω_0 , e , m , and γ are the electric field amplitude, the resonant frequency, the electric charge, the mass of the electron, and the damping constant, respectively [11]. We can multiply the quantity described in (21) by e to get the dipole moment vector. We additionally multiply by the dipole density N to get the bulk polarization. We see in (9) that the displacement field is equal to the added

effect of the field and the polarization response of the material. However, we get a different value because we are not dealing in the plasmonic regime. The relative permittivity or the square of the index n is expressed as

$$n^2(\omega) = \frac{\epsilon(\omega)}{\epsilon_0} = 1 + \frac{Ne^2/\epsilon_0 m}{(\omega^2 - \omega_0^2) + j\gamma\omega} \quad (22)$$

We can further imagine that there are a certain number of mechanical systems operating simultaneously. This means that for the i th system, there will be a certain fraction of atoms f_i in that system; i.e., the effective dipole density for the i th system is $f_i N$.

$$\begin{aligned} n^2(\omega) &= \sum_i^Z 1 + \frac{f_i \left(\frac{Ne^2}{m\epsilon_0} \right)}{(\omega^2 - \omega_i^2) + j\gamma_i\omega} = \sum_i^Z 1 + \frac{f_i \left(\frac{Ne^2}{m\epsilon_0} \right)}{\left(\frac{4\pi^2 c^2}{\lambda^2} - \frac{4\pi^2 c^2}{\lambda_i^2} \right) + \frac{j2\pi c\gamma}{\lambda}} \\ &= \sum_i^Z 1 + \frac{f_i \left(\frac{Ne^2}{m\epsilon_0} \right) \lambda^2}{\left(4\pi^2 c^2 - \frac{4\pi^2 c^2 \lambda^2}{\lambda_i^2} \right) + j2\pi c\gamma\lambda} = \sum_i^Z 1 + \frac{f_i \lambda_i^2 \left(\frac{Ne^2}{m\epsilon_0} \right) \lambda^2}{\left(4\pi^2 c^2 \lambda_i^2 - 4\pi^2 c^2 \lambda^2 \right) + j2\pi c\gamma \lambda_i^2 \lambda} \end{aligned} \quad (23)$$

where c is the speed of light.

We then make the assumption that γ , the damping constant, goes to zero for the assumption of a simple harmonic oscillator.

$$n^2(\lambda) = \sum_i^Z 1 + \frac{f_i \lambda_i^2 \left(\frac{Ne^2}{4\pi^2 c^2 m\epsilon_0} \right) \lambda^2}{(\lambda_i^2 - \lambda^2) + \frac{j\gamma \lambda_i^2}{2\pi c} \lambda} \underset{\gamma \rightarrow 0}{\approx} \sum_i^Z 1 + \frac{f_i \lambda_i^2 \left(\frac{Ne^2}{4\pi^2 c^2 m\epsilon_0} \right) \lambda^2}{(\lambda_i^2 - \lambda^2)} \quad (24)$$

We can make further simplifications to say that

$$n^2(\lambda) = \sum_i^Z 1 + \frac{G_i \lambda^2}{(\lambda_i^2 - \lambda^2)}, \quad (25)$$

where λ_i is the i th resonant wavelength and the coefficient G_i is the strength of that resonance. The coefficient G_i is expressed as

$$G_i = \left(\frac{Ne^2}{4\pi^2 c^2 m\epsilon_0} \right) f_i \lambda_i^2 \quad (26)$$

These coefficients are known as Sellmeier coefficients [15]. These coefficients play a role in determining the group velocity of a particular wavelength in a fiber.

One of the misconceptions brought about by our knowledge of lasers is the “myth of monochromaticity.” The light sources we use—even for optical fibers—are never fully monochromatic. Rather they emit a spectrum of frequencies (and wavelengths) concentrated around a particular center [16]. This spectrum will generate respectively scaled eigenmodes with their own group velocities and delays through the fiber. This causes pulse broadening even when only a single mode is propagating.

For a typical laser with a homogenous linewidth undergoing natural line broadening due to atomic decay, we can express the line-shape function as a typical Lorentzian for which

$$\phi_N(\nu) = \frac{1}{\pi} \frac{\Delta\nu_N/2}{(\nu - \nu_0)^2 + \left(\frac{\Delta\nu_N}{2}\right)^2}, \quad (27)$$

where $\Delta\nu_N$ is the FWHM frequency point or the natural linewidth [17]. This is the spectral profile of a typical laser centered around a frequency $\nu = \nu_0$. We can convert this line-shape function to one of the k -vector k where

$$\phi_N(k) = \frac{1}{\pi} \frac{\Delta\nu_N/2}{\left(\frac{k c}{2\pi} - \frac{k_0 c}{2\pi}\right)^2 + \left(\frac{\Delta\nu_N}{2}\right)^2} = \frac{2\pi\Delta\nu_N/c^2}{(k - k_0)^2 + \left(\frac{\pi\Delta\nu_N}{c}\right)^2}. \quad (28)$$

where k_0 is the center spatial frequency.

The spectrum described in (28) shows that there is an uncountable infinity—i.e., a continuum—of k -vectors (and thus wavelengths) that is allowed.

In the case of a gas, the same can be done with the Boltzmann relation that is used to compute the statistical distribution of velocities (and thus k -vectors) under Doppler [18] broadening where the velocity component v is normally distributed $\mathcal{N}(0, k_B T/m)$ while the energy E undergoes a chi-squared distribution $\chi_1^2(E)$ as shown in (28):

$$P(v) = \sqrt{\frac{m}{2\pi k_B T}} e^{-\frac{mv^2}{2k_B T}} \leftrightarrow_{E=mv^2/2} P(E) = \frac{1}{\sqrt{4\pi k_B T}} \frac{e^{-\frac{E}{k_B T}}}{\sqrt{E}} \quad (29)$$

where m, k_B, T , and v are the particle's mass, Boltzmann's constant, the temperature, and the velocity, respectively.

Because of the Doppler effect, the radiation will be shifted to a higher frequency ν which can be expressed as

$$\nu = \nu_0 \left(1 + \frac{v}{c}\right) \quad (30)$$

where ν_0 is the center frequency.

With (30) in mind, we can rewrite (28) in terms of ν and convert to the k -domain like so

$$P(\nu) = \frac{c}{\nu_0} \sqrt{\frac{m}{2\pi k_B T}} e^{-\frac{m c^2 (\nu - \nu_0)^2}{2\nu_0^2 k_B T}} \leftrightarrow P(k) = \frac{c}{k_0} \sqrt{\frac{m}{2\pi k_B T}} e^{-\frac{m c^2 (k - k_0)^2}{2k_0^2 k_B T}} \quad (31)$$

What this means is that in the case of a realistic laser, dispersion within a confined medium will result even if the medium allows for only *one* mode to be activated. This is to say that Lorentzian homogenous broadening and Gaussian Doppler broadening *both* result in intramodal pulse broadening.

What is interesting is the counterintuitive connection between the frequency broadening and the temporal pulse broadening as their behaviors mirror each other. However, this is because we are dealing with *two* separate systems that happen to be connected. The first system is that of the laser linewidth and the decaying atoms and spontaneous thermal processes that diminish monochromaticity. These processes spread the spectrum out and a broader range of frequency (and wavelength) contribution to the spectrum. The second system is that of the delays accrued within the fiber-waveguide channel according to the wavelength contributions of the input spectrum. The input laser spectrum allows for a larger contribution to delays that will be “experienced” by the larger range of frequency and wavelength components, which *broaden* the temporal profile of the signal.

As noise is intrinsic to a lasing system so is dispersion when that system is directed into a medium; this is especially true in the context of confined or *bounded* media and their applications in modern communication networks.

8. Conclusion

Dispersion has been discussed in this chapter as it relates to electric fields in various media. We first begin with an understanding of electron responses to EM radiation; i.e., the light-matter interaction as understood in classical electromagnetics. When then used this concept to understand how the velocity of a signal through a medium is a function of the frequency of that signal.

Additionally, we explained and developed the concept of a group velocity with a simple analogy and then moved on to discuss that concept at length in various media. We contrasted group velocity with phase velocity and developed dispersion relations which contrasted the two.

We took the discussion of dispersive materials to light-confining structures. Optical waveguides and fibers function as dispersive materials not only because of their material properties but also because these materials are arranged. The arrangement of these materials—i.e., core-cladding indices, size, index distribution, etc.—all plays a role in the phenomenon of dispersion. This also influences the allowable forms of light that propagate in one of these confined media; the properties of the medium affect these modes of propagation. We additionally learned about ways in which this effect can be eliminated for engineering applications.

We finally ended this chapter with a discussion of effect of intramodally dispersive media on the frequency spectrum and time evolution of electric field signals. This was demonstrated by first dismantling the “myth of monochromaticity” and understanding light itself as a spectrum. This helped us better understand how a single mode can undergo dispersion with itself. It most importantly demonstrated the degree to which dispersion is inherent in EM propagation through all media.

IntechOpen

Author details

Emeka Ikpeazu

University of Virginia, Charlottesville, Virginia, United States of America

*Address all correspondence to: eikpeazu@gmail.com

IntechOpen

© 2020 The Author(s). Licensee IntechOpen. This chapter is distributed under the terms of the Creative Commons Attribution License (<http://creativecommons.org/licenses/by/3.0>), which permits unrestricted use, distribution, and reproduction in any medium, provided the original work is properly cited. 

References

- [1] Le Bourhis E. Appendix 1. Glass; Mechanics and Technology. 1st ed. Weinheim: Wiley-VCH; 2007
- [2] Rao NN. Waveguide Principles. Fundamentals of Electromagnetics for Electrical and Computer Engineering. 1st ed. Upper Saddle River, NJ: Pearson/Prentice Hall; 2009. pp. 290-338. DOI: 10.1002/978047974704.ch8
- [3] Isaac N. Opticks. London: Royal Society; 1704. ISBN: 0-486-60205-2
- [4] Staelin DH. Electromagnetics and Applications. Cambridge, MA: Department of Electrical Engineering and Computer Science, Massachusetts Institute of Technology; 2011
- [5] Charles K. Introduction to Solid State Physics. 8th ed. Hoboken, NJ: Wiley; 2005
- [6] Newman R, Tyler WW. Photoconductivity of germanium. In: Seitz F, Turnbull D, editors. Solid State Physics. Vol. 8. New York: Academic Press; 1959. pp. 49-107
- [7] Rao NN. Waveguide Principles. Fundamentals of Electromagnetics for Electrical and Computer Engineering. 1st ed. Upper Saddle River, NJ: Pearson/Prentice Hall; 2009. p. 142. DOI: 10.1002/978047974704.ch8
- [8] Chen LF, Ong CK, Neo CP, Varadan VV, Varadan VK. Microwave Electronics: Measurement and Materials Characterization. 1st ed. Chichester: Wiley; 2004
- [9] Rao NN. Waveguide Principles. Fundamentals of Electromagnetics for Electrical and Computer Engineering. 1st ed. Upper Saddle River, NJ: Pearson/Prentice Hall; 2009. p. 143. DOI: 10.1002/978047974704.ch8
- [10] Engineering ToolBox. Relative Permittivity—The Dielectric Constant [online]. 2010. Available from: https://www.engineeringtoolbox.com/relative-permittivity-d_1660.html [Accessed: 09 October 2019]
- [11] Pollock CR. Dispersion in Waveguides. Fundamentals of Optoelectronics. 1st ed. Chicago: Irwin; 2003
- [12] Mitschke F. Fiber Optics: Physics and Technology. Heidelberg, Dordrecht, London, New York: Springer; 2009. p. 22
- [13] Mitschke F. Fiber Optics: Physics and Technology. Heidelberg, Dordrecht, London, New York: Springer. 2009. p. 21
- [14] Pollock CR. Graded-index Waveguides. Fundamentals of Optoelectronics. 1st ed. Chicago: Irwin; 2003
- [15] Sellmeier W. Über die durch die Aetherschwingungen erregten Mitschwingungen der Körpertheilchen und deren Rückwirkung auf die ersteren, besonders zur Erklärung der Dispersion und ihrer Anomalien (II. Theil). *Annalen der Physik und Chemie*. 1872;223(11):386-403
- [16] Kasap SO. Optoelectronics and Photonics—Principles and Practices. 1st ed. Upper Saddle River, NJ: Prentice Hall; 2001. p. 78
- [17] Peach G. Theory of the pressure broadening and shift of spectral lines. *Advances in Physics*. 1981;30(3):367-474
- [18] Siegman AE. Lasers. 1st ed. Mill Valley, CA: University Science Books; 1986