

# We are IntechOpen, the world's leading publisher of Open Access books Built by scientists, for scientists

**5,000**

Open access books available

**125,000**

International authors and editors

**140M**

Downloads

Our authors are among the

**154**

Countries delivered to

**TOP 1%**

most cited scientists

**12.2%**

Contributors from top 500 universities



**WEB OF SCIENCE™**

Selection of our books indexed in the Book Citation Index  
in Web of Science™ Core Collection (BKCI)

Interested in publishing with us?  
Contact [book.department@intechopen.com](mailto:book.department@intechopen.com)

Numbers displayed above are based on latest data collected.

For more information visit [www.intechopen.com](http://www.intechopen.com)



# Development of a Rough Terrain Wheelchair Design

*Ignatio Madanhire, Loice Gudukeya and Roy Mushonga*

## Abstract

Conventional wheelchairs do not cope well in less-resourced rural areas as they are not stable and can topple easily. This chapter seeks to develop a wheelchair design that offers optimum stability and comfort for people in rural areas where there is rough and uneven terrain environment. The design development process entailed the generation of three possible wheelchair design concepts. Wide rear wheel design was further developed to come up with a detailed design with a maximum tipping angle of 43.17 degrees. This could be considered to be a great improvement compared to the conventional wheelchair configuration. The design was made to function using a ratchet lever bar to push the rear wheels forward to initiate motion. It was established that fabrication of the prototype could be done easily at a lower cost cap of USD200 using locally available materials. The proposed wheelchair design would improve the mobility and consequent living conditions of those disabled individuals living in rough terrain rural set up environments.

**Keywords:** wheelchair, stability, rough terrain, off-road, uneven ground, design, rural

## 1. Introduction

Wheelchairs may take a variety of forms to meet particular needs of users. Such configurations may entail specialized seating set up, individualized controlling mechanisms, and in some cases specific to certain activities, as is the case with sports and beach wheelchairs [1]. The commonly known distinction among wheelchairs is between powered wheelchairs, where mobility is powered by batteries and electric motors, and manual propulsion, where the propulsive force is provided by the user pushing the wheelchair by hand, or by having someone pushing from the rear [2].

The user of a standard wheelchair, when utilizing the wheelchair on rough terrain, is confronted with a plenty of difficulties. The most exceedingly awful being, the unsteadiness brought about by a high position of gravity point from the wheel contact with the ground [3]. In this manner wheelchair may topple over in reverse during negotiating steep slanted territory. When horizontally navigating a steep grade, the wheelchair is probably going to tip sideways [4]. During descending a slope, the operator may risk sliding out of the seat or having the seat unstable and having a forward pitch [5].

Most wheelchair designs are not conducive for use in rough terrain (**Figure 1**) found in the rural country side, nonetheless this should not discourage those who are



**Figure 1.**  
*Rough terrain [5].*

unable to walk to work for themselves and earn a living [6]. It is in this regard that some effort has been made to improve the mobility of wheelchair users so that they are able to move from one point to the other despite how rough the terrain maybe.

## 2. Background

Users of wheelchairs continue to encounter some difficulties as they seek to navigate from one point to the other on rough terrain due to lack of stability when using rural off-road environment pathways [4]. Most existing wheelchairs are not suitable for use on extremely rough terrain thereby compromising the safety of the occupant [7]. Hence the objective of this chapter to design a wheelchair frame that offers optimum stability on rough terrain and does not readily overturn.

Effort to navigate extreme rugged pathways in a rural setting could be a challenge, such that even a great modern wheelchair may be found to be of limited usefulness [8]. What could be needed is an off-road design that is easy to manufacture and repair compared to designs done for a city environment where there are sidewalks. All terrain wheelchairs can increase the mobility range and access by taking occupant where one always wanted to go but were not able [9]. All terrain wheelchairs could be in various shapes and sizes, powered, manual and sometimes with a lever drive. Some have specific advantages such as the ability to maneuver on loose terrain covered by sand or gravel, in snow, over hilly terrain or on hills [10].

It is the unstable nature of existing wheelchair frames that demands for a wheelchair design modification to ensure increased increase stability on “non-ideal” terrain surfaces. Such rugged terrain may entail (but are not limited to): gravel, grass, dirt, and cracked asphalt or concrete. A wheelchair design modification is required for successful traversing of the adverse terrain while keeping four points of contact between the wheels and ground as well as maintaining the required stability

and comfort for the operator [11]. It is the intention of this chapter to improve the current design within a reasonable cost range that most users within the rural area and other low-income earners category can afford to buy.

### **3. Wheelchair literature review**

#### **3.1 Design and standards**

The intended mandate is come with a design with improved performance that provides requisite seating and postural support without compromising strength, durability and safety [12]. The International Organization for Standardization (ISO) formulated international standards for wheelchair frames, the ISO 7176 series (1). The series specify the relevant terminology and testing processes to evaluate wheelchair parameters such as performance, size, strength, durability and safety. In some cases, the required conditions in the ISO 7176 series may not capture all typical requirements in less-resourced environment, as some of the requirements were meant to simulate the conditions in city environs with smooth tarred roads. It is therefore necessary to consider varied environments when formulating national standards, by looking at key parameters such as the weights and sizes of users, typical uses, and the available wheelchair designs and associated technologies within the country [13].

#### **3.2 General considerations**

Wheelchair configuration should afford users to partake in whatever number life exercises as could be allowed. As a base prerequisite, a wheelchair ought to allow the operator to lead an increasingly dynamic existence without having any antagonistic impact on one's well-being or security. Solace and well-being comprise the two significant perspectives that influence the personal satisfaction of happy wheelchair users [14]. The well-being and security of operators ought not to be undermined so as to lessen costs during structure improvement. In spite of the fact that it might be contended that any wheelchair is superior to no wheelchair, this cannot be correct when the wheelchair turns into the reason of well-being dangers. It is in this respect a wheelchair ought to be intended to guarantee the client's improved great well-being and convenience [15].

#### **3.3 Common wheelchair limitations**

The basic difficulties that a standard wheelchair faces involve challenges while crossing lopsided surfaces or negotiating hindrances in the pathway. Such problems may be the failure to continue any further when a wheel gets stuck in a downturn, with the end result that when the user endeavors to free oneself, the seat may get agitated and topples [7]. A comparative issue, with similar results, may happen when endeavoring to cross obstructions, for example, rocks, logs or curbs the pathway (**Figure 2**). A surface not smooth, covered with scrub and stones, may likewise be considered as uneven or unpredictable consequently imposing difficulties to mobility.

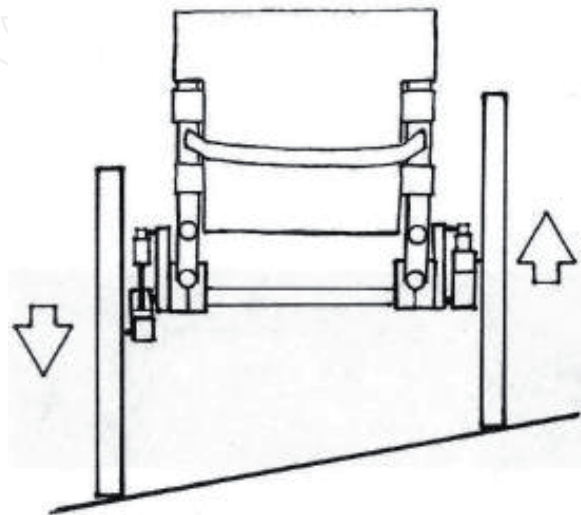
There are also cases where the user may be unable to generate enough sustained human power to climb steep grades. Thus, the conventional wheelchair has limited capability to traverse steep inclines [7]. The standard wheelchair typically uses narrow width pneumatic tires which can easily get punctured by branches, rocks and the like. When utilized in sandy, loose and unstable soil, the wheels sink and the occupant may get stuck in the process [16].



**Figure 2.**  
*Rock obstructions [7].*

### 3.4 Mechanisms to negotiate uneven terrain

The system should allow for significantly more maneuverability on uneven (off-camber) terrain than the standard wheelchair. The suspension would manage the off-camber surfaces through autonomous adjustments (**Figure 3**), when the user



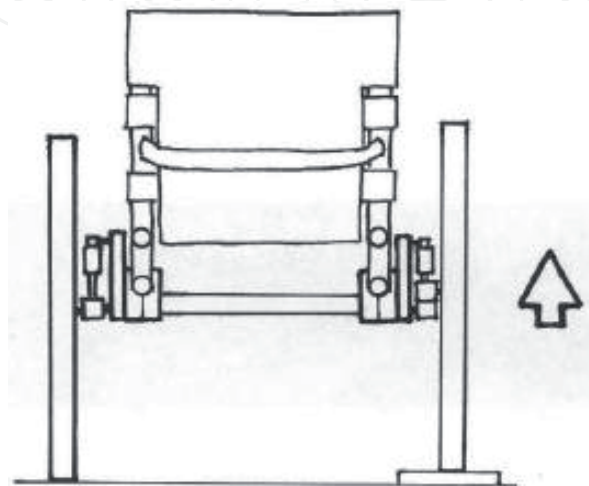
**Figure 3.**  
*Independent suspension travel [18].*

is on an incline of around 10 degrees. As the right shock compresses and the left relaxes, consequently enabling the seat to level itself, offering greater stability to the wheelchair structure seat. The determination of shocks ought to take into consideration autonomous control of spring rate and damping ratio, consequently enabling the system work even in a stationary situation as well [17].

Different obstacles may require the suspension to work autonomously, for instance, a block of wood or a crack in the walkway can be effectively explored with the same suspension framework. As given in **Figure 4**, the right side of the wheelchair must articulate upwards so as to keep up all the four wheels in contact with the ground surface, as the wheelchair moves over the obstructions. The right rear shock compresses, while the others adjust to equilibrium, allowing for all four wheels to have some type of contact, and a resulting good stability is achieved [18].

The operators explore obstructions in their everyday life. A number of these snags require autonomous wheel articulation, while others may require the shocks to work in unison. A typical impediment that wheelchair clients face everyday (or avoid) is the street curb. Assuming the user is moving on a path perpendicular to the curb, the wheels will act in unison as the back end of the chair rolls off of the curb, with the suspension absorbing the force. This is not a navigation that could be safely done in a conventional wheelchair [18].

In some cases, there can be need to attach a set of wide auxiliary wheels or wheel extensions to the standard wheelchair for it to be stable when used off road on sandy, loose or unstable terrain. Of late, a couple of expansive tire-like plastic or elastomeric treads are connected and fitted onto the back wheels of the wheelchair to give a substitute handhold grip to the user in a way similar to mounted standard wheels arrangement above [19]. The treads are additionally marginally recessed inward from the original tire, being of a smaller diameter than the back wheel, to allow the wheelchair to ride exclusively on the tire on hard surfaces and make drive on such surfaces equivalent to one would typically anticipate. The treads act together with a second pair of lightweight plastic wheels which are adjusted to fit on either side of every one of the two stanchion mounted front wheels, the combination acting to give an broad bearing surface to better steadiness, load bearing capacity and simpler controlling of said vehicle when utilized on said sandy, loose or shaky landscapes. The wheelchair may likewise be fitted with an anti-tip over mechanical assembly to prevent flipping in reverse when navigating difficult landscape and to allow the wheelchair to be moved in an upward angled position which puts the most substantial portion of the weight on the back wheel, increasing grip on the shaky terrain [19].



**Figure 4.**  
*Independent pass over obstacle [18].*

Push-bar outfitted gadget permits structures that allow people of varying physical strength to move the wheelchair along a wide scope of landscapes, including delicately tricky terrain. The push-bar enable the users to initiate mobility without hand to wheel system. The unique design drives the chair forward with a forward movement of the drive bars while pulling back on the push-bars effects the braking mechanism. Turning is accomplished with a forward movement on one push-bar and a backward movement on the other push-bar. The off-road seat of this design offers the operator a multi-speed equipped favorable advantage over traditional wheelchairs. Changing into lower gears for very adverse terrain such as sandy environment, gives the operators the opportunity to go where they have not had the option to go with conventional wheelchairs. Just changing into higher gears considers allows for movement on pavement and other hard surfaces. The push-bars are removable and may consequently be put away with so that the wheelchair might be moved utilizing traditional hand-to-wheel pushing [20]. This component enables the user to deal with a wide range of landscapes and conditions that are normally restrictive to operators of ordinary wheelchairs and power wheelchairs to be used particularly in open air situations and elements for example forest floors, uneven and harsh terrain. Further, it very well may be utilized to conquer numerous every day snags, for example, curbs and high thresholds [21]. It is advantageous for people with less upper body and arm strength. Accordingly, it accommodates more independent participation in open air exercises, such as hunting, chasing, and so forth.

The review above points toward one thing that current rough terrain wheelchairs do not provide total stability (“not ideal”). Thus, there is still a need to come up with a wheelchair that will prevent the user either toppling backward, forward or sideways.

#### **4. Materials and methods**

The design development process entailed coming up with a design that improves the wheelchair stability mechanism, safety precautions as well as reduce power-ing requirements. Some investigations were done on existing all-terrain stability mechanisms, including the possibility of redesigning the wheels and adjusting the center of gravity for improved stability. The safety of the operator, the machine and influence to the nearby environment were considered among other key parameters. Some effort was made to ensure that the final framework of the wheelchair would address the issues of user safety.

The researchers carried out a study on current wheelchair powering methods as well as noting their efficiencies. Power transmission mechanism was fundamental in achieving speed and power. Some engagement with different disability organizations was done to acquire first hand expectations of users.

The generated design concepts were evaluated and analyzed for suitability for adoption. The chosen concept was further developed to come up with dimensions of the wheelchair, sizing of the wheelchair parts, material selection and detailed drawing of the final design. The detailed drawings were drawn using AutoCAD (2007) and Autodesk Inventor (2017) was used to simulate the strength of the wheelchair frame. The bill of materials was drawn up and the cost estimate and the feasibility of fabricating the prototype unit in the local workshop were done.

#### **5. Design concept generation**

The concepts were formulated based on the ability of the design to meet the objective criteria which were: reliability, maintainability, efficiency, robustness,

machinability, stability, safety, cost, ease of operation, and weight. Three possible design solutions were generated for the off road wheelchair as explained in the following sections.

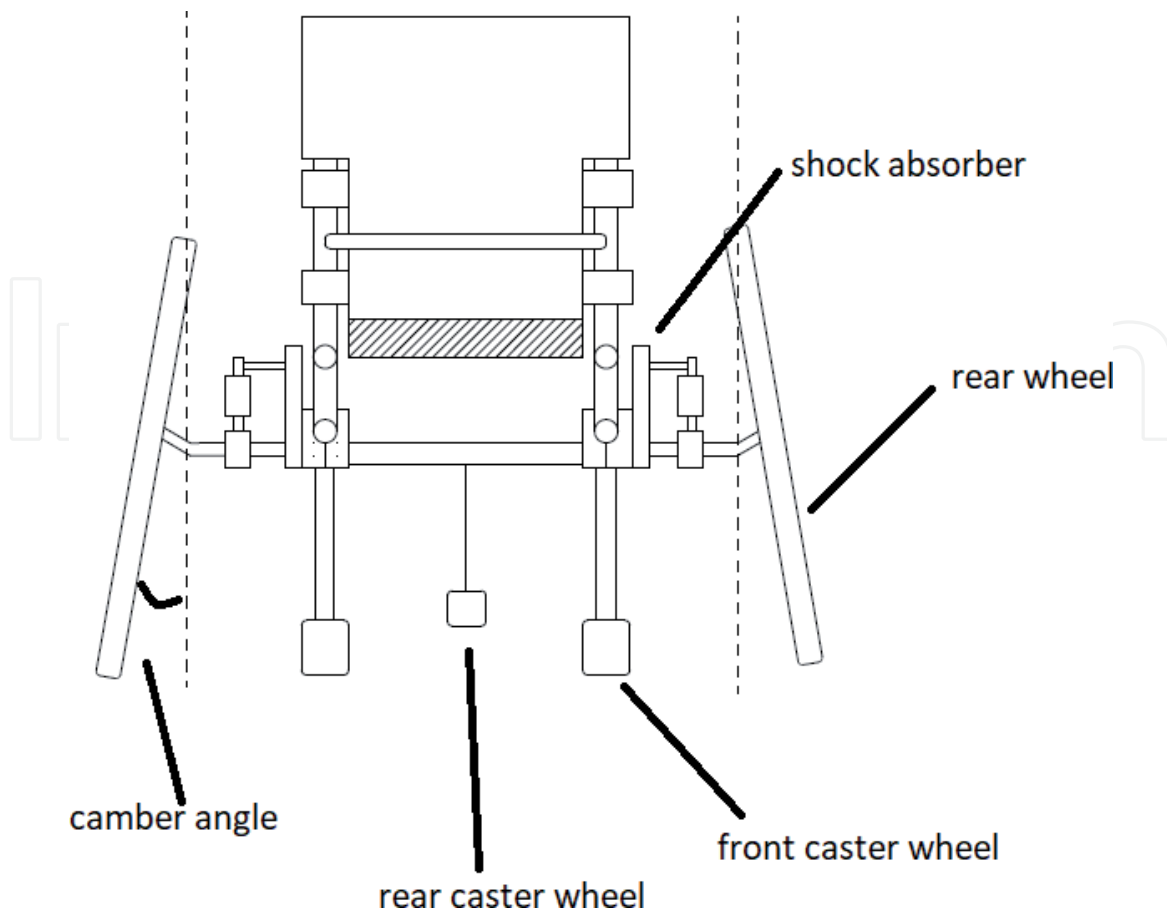
### 5.1 Cambered rear wheels concept

The wheelchair is operated like a normal conventional wheelchair, by pushing the wheels forward. Sideways stability is affected by wheelchair width (**Figure 5**). The rear wheels are tilted inwards to increase the base width thus stabilizing the chair. A back-caster wheel is fitted to prevent the wheelchair from falling backwards.

The further out to the side of the wheelchair base, the more the chair resists tipping over sideways. The camber pushes the wheels nearer to the wheelchair user and more in accordance with the operator's forward push stroke, therefore making it simpler to push. This can be particularly useful for ladies, who normally have smaller shoulders yet more extensive hips than men. Additionally, with cambering, traction is improved when navigating slopes. The wheelchair provides more stability, comfortable seating and it is better for overweight people. On the other hand, a wide wheelchair is more difficult to get through narrow pathways as camber increases the width of the wheelchair. Most anti-tip designs restrict the wheelchair's ability to travel over uneven surfaces (such as kerbs or dips). It is also hard to push.

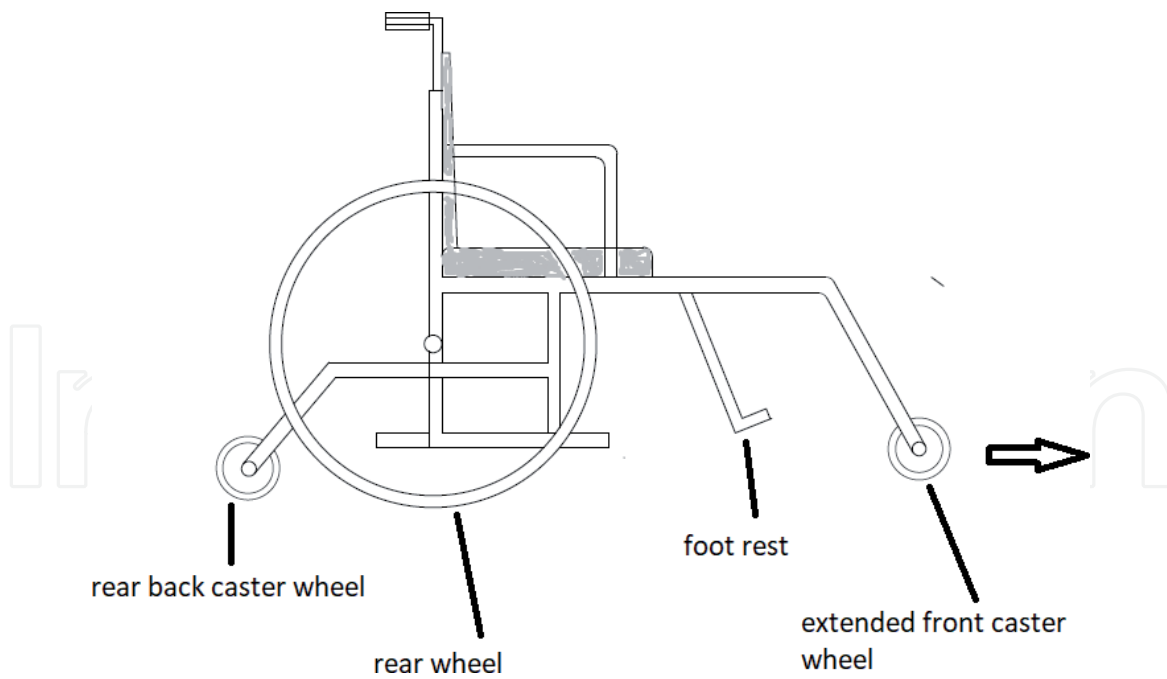
### 5.2 Extended front caster wheels concept

The user propels the wheelchair forward by pushing the rear wheels to the front. A back-caster wheel is fitted to prevent the wheelchair from tipping backwards.

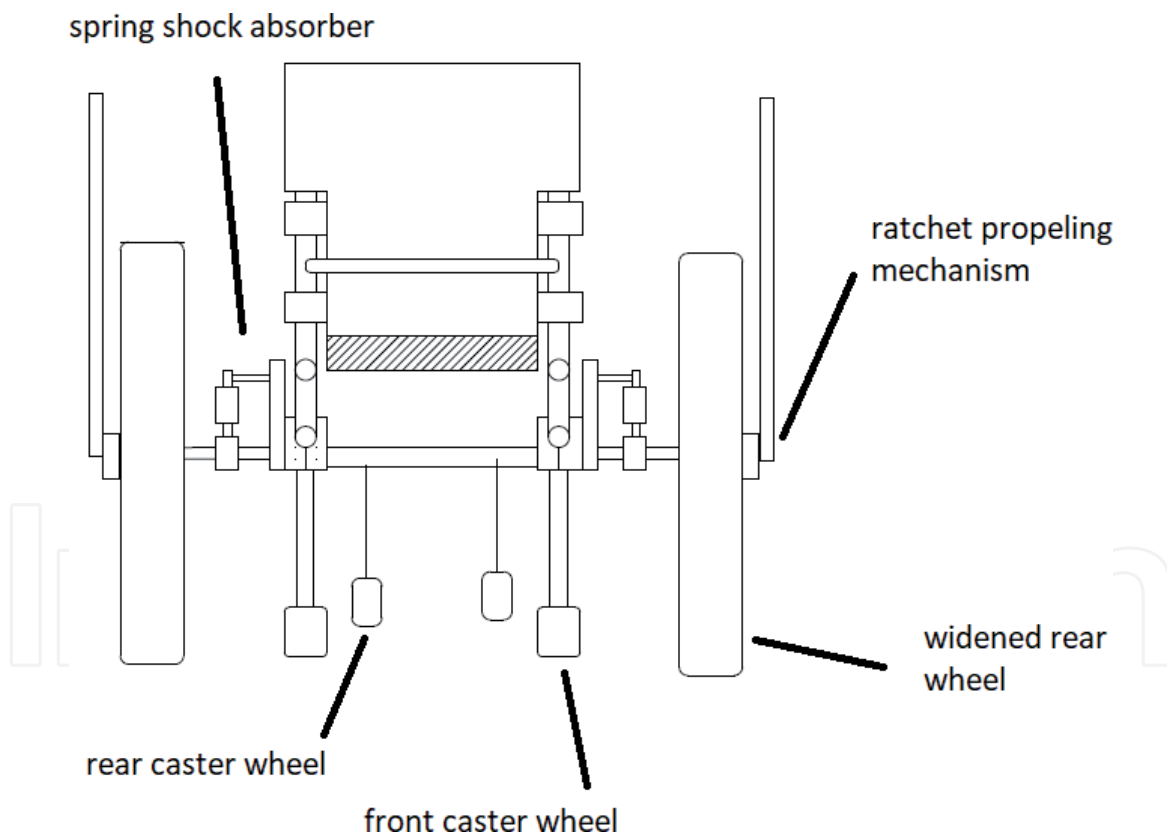


**Figure 5.**  
*Cambered rear wheels.*





**Figure 6.**  
*Extended front castor wheels.*



**Figure 7.**  
*Widened rear wheels [12].*

Forward stability is affected by the size and position of the front castor wheel in relation to the operator's center of gravity. The front castor wheels of the above wheelchair in **Figure 6** are extended to the front to provide forward stability.

The wheelchair resists tipping forward when the castor wheels are stopped suddenly by an object they cannot roll over. Less weight on the front wheels will reduce the rolling resistance of the front wheels, allowing the wheelchair to roll more easily. More of the user's weight on the rear wheels will provide more traction on

the rear wheels to drive through soft ground. On the downside, overall wheelchair length is longer, making it harder to maneuver in confined spaces.

### 5.3 Widened rear wheels concept

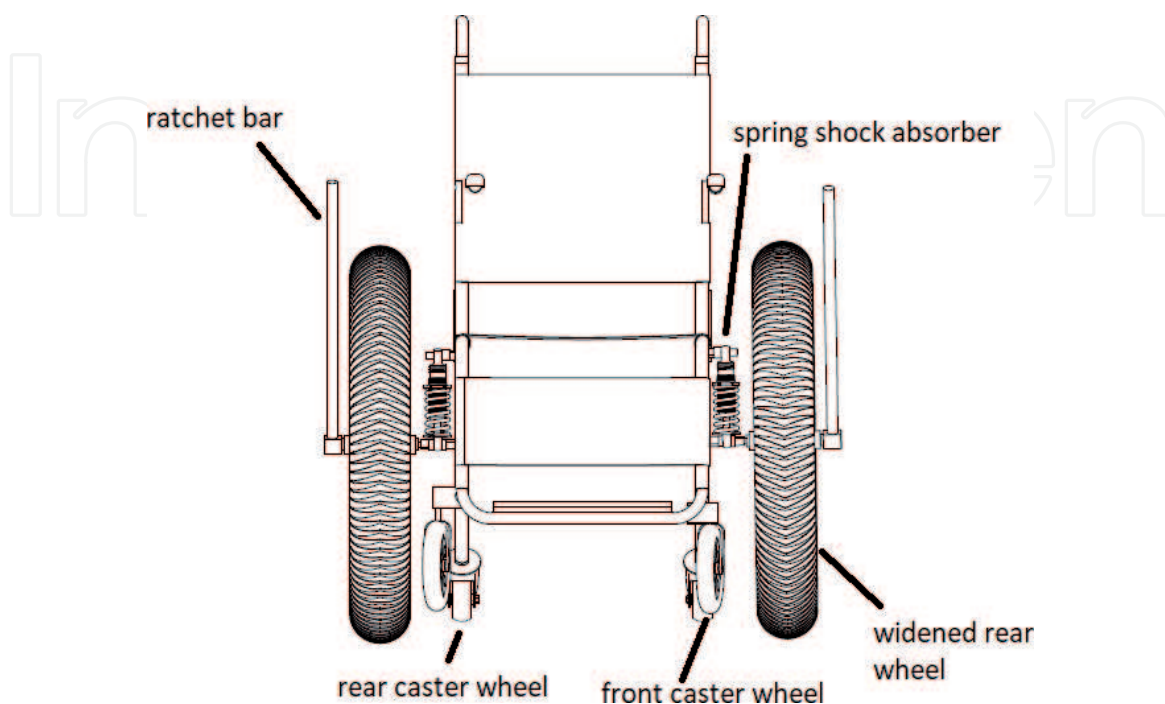
Sideways stability is affected by wheelchair width, thus the need for wide rear wheels. A ratchet arm assembly is operatively connected to each of the rear wheels to enable the operator to propel the wheelchair by that method, should the person so choose. Shock absorbers are fitted to the rear wheels to provide independent wheel articulation, such that if one wheel is to go over an obstacle the other one remains on the ground (**Figure 7**).

The further out to the side of the wheelchair the front and rear wheels touch the ground, the more the chair will resist tipping over sideways. The width of the rear wheels increases their bearing ability such that when utilized in sandy, loose or unstable terrain they do not sink into the underlying terrain and loose traction resulting in the occupant being left stuck. The wheelchair becomes easy to push and there is increased stability. On the downside a wide wheelchair is more difficult to get through narrow pathways. Side way stability is limited due to vertical wheels.

Using the binary dominance matrix method, widened rear wheels concept was chosen for further development. The mechanical design of this concept was developed into the final design in the next section of this chapter.

## 6. Detailed wheelchair design

The widened rear wheels design concept was further designed in detail. The parts making up the system were sized and materials for the parts selected according to the design standards for mechanical parts. The designed parts were tested to configure if they could withstand the operating stresses and adjustments if any were taken in order to minimize failure of the parts during operation. The main parts are the widened rear wheels, ratchet bar, spring shock absorbers, rear caster wheels and front caster wheels given in **Figure 8**.



**Figure 8.**  
*Detailed design assembly.*

## 6.1 Center of gravity

The center of gravity (CG) is the focal point of a body's weight appropriation, where the force of gravity can be considered to act. It is the point in any object about which it is in perfect balance regardless of how it is turned or pivoted around that point. For a limited arrangement of point masses, CG might be characterized as the normal of positions weighted by mass. For its figuring a few parameters were viewed as, for example, the thickness of the material, the volume of the piece and the good ways from the origin arrange around the focal point of the piece. This is critical for the stability of the wheelchair. Thus considering x, y and z axis the center of gravity of the point masses will be given, and to find the center of gravity of composite bodies this was considered in the detailed design.

## 6.2 Calculations of stress and failure

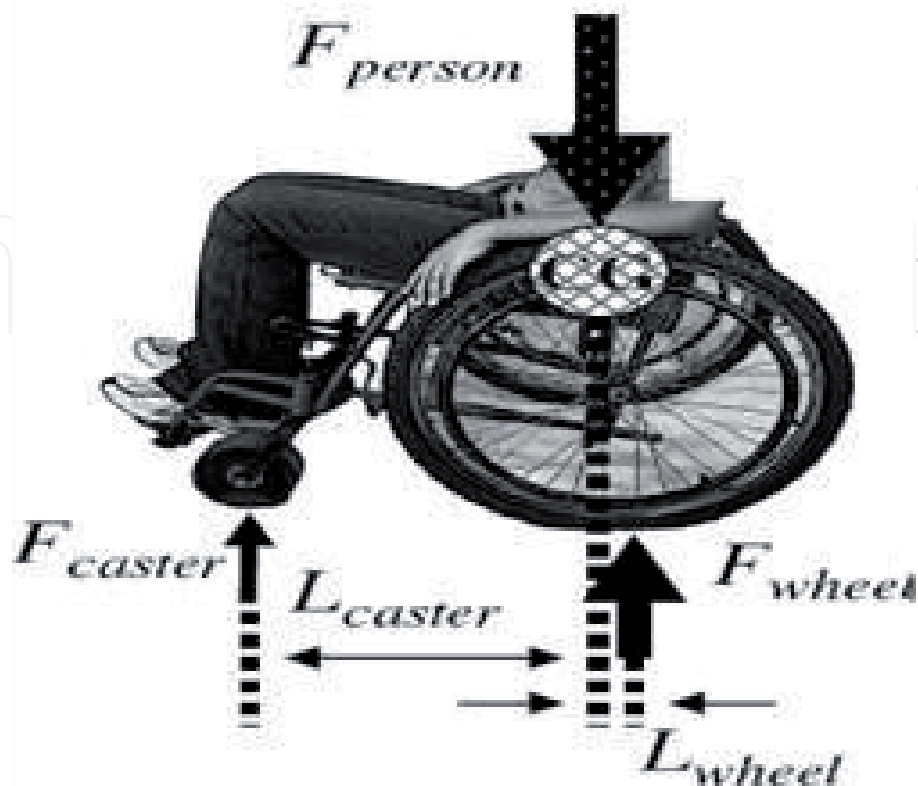
Forces on a wheelchair casters and wheels, when the assumption is that the operator weighs 100 kg (**Figures 9–12**) (Eqs. (1)–(3)).

$$\text{Considering: } F_{person} = F_p = 981N \text{ (100 kg)} \quad (1)$$

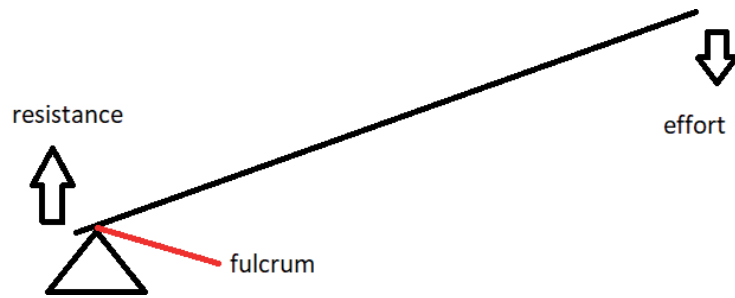
$$L_{caster} = L_c = 315.81 \text{ mm} \quad (2)$$

$$L_{total} = L_c + L_w = 448.11 \text{ mm} \quad (3)$$

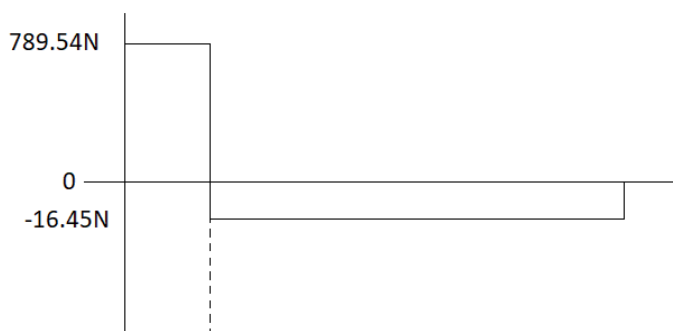
The findings are that each rear wheel will take a weight force of 345 N. While the caster wheel takes 144.815 N.



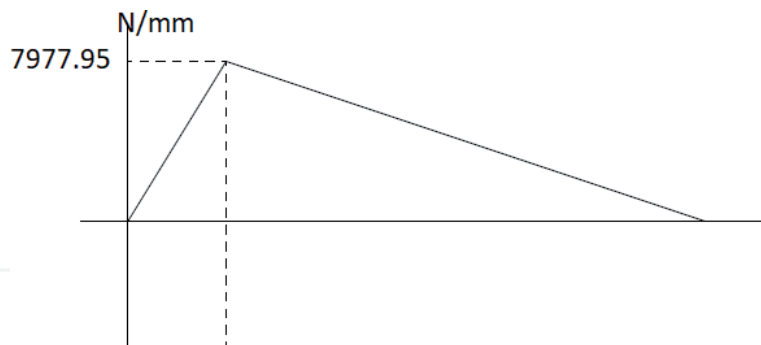
**Figure 9.**  
Force analysis [3, 13].



**Figure 10.**  
 Ratchet set up [13].



**Figure 11.**  
 Shear force diagram on the ratchet lever [13].



**Figure 12.**  
 Bending moment diagram [13].

### 6.3 Internal moments and forces in a wheelchair axle

The forces and moments acting on the back hub of a wheelchair were determined a similar path as above. The greatest moment exists where the hub is welded to the frame. There are vertical forces applied on the wheel starting from the ground, there likewise might be horizontal forces that act on the wheel when the wheelchair tips over, these forces cause moments on the axle. Von Mises stresses were analyzed for the axle to take note of the critical points.

### 6.4 Bending stress in a wheelchair axle

At the point when a section is twisted the applied moment creates stresses in the material. On one side of the part the material is extended and in this way has tensile

stresses. On the opposite side the material is compressed by compressive loading. The maximum bending moment was found to be 62.125 MPa.

### 6.5 Stress and failure

Shear stress is the stress that attempts to tear something separate. It is characterized as the shear force divided by the area over which the force is acting. In a wheelchair hub, its value is low and is rather higher in the X-brace pivot of a wheelchair. The modulus of elasticity (E) is a material property that tells how much a material make an effort not to distort when it is under stress. Strain is the proportion of how a lot of a material twists when under pressure.

Looking at the most extreme bending stress in a wheelchair axle with the limit elastic of the material used, it is possible to know whether the hub is sufficiently strong enough to hold up under the individual user's weight and other external forces applied on it. The weight of the person should not exceed 212.33 kg.

### 6.6 Shock absorber spring

The material of the spring should have high fatigue strength, high ductility, high resilience and it should be creep resistant, hence carbon steel was chosen. The free length of 100 mm and the spring wire diameter was determined to be 5 mm.

### 6.7 Ratchet bar

The ratchet is used to turn the wheels by the operator. The effort by the operator was determined to be 16.45 N, at the top of the lever assuming the frictionless movements.

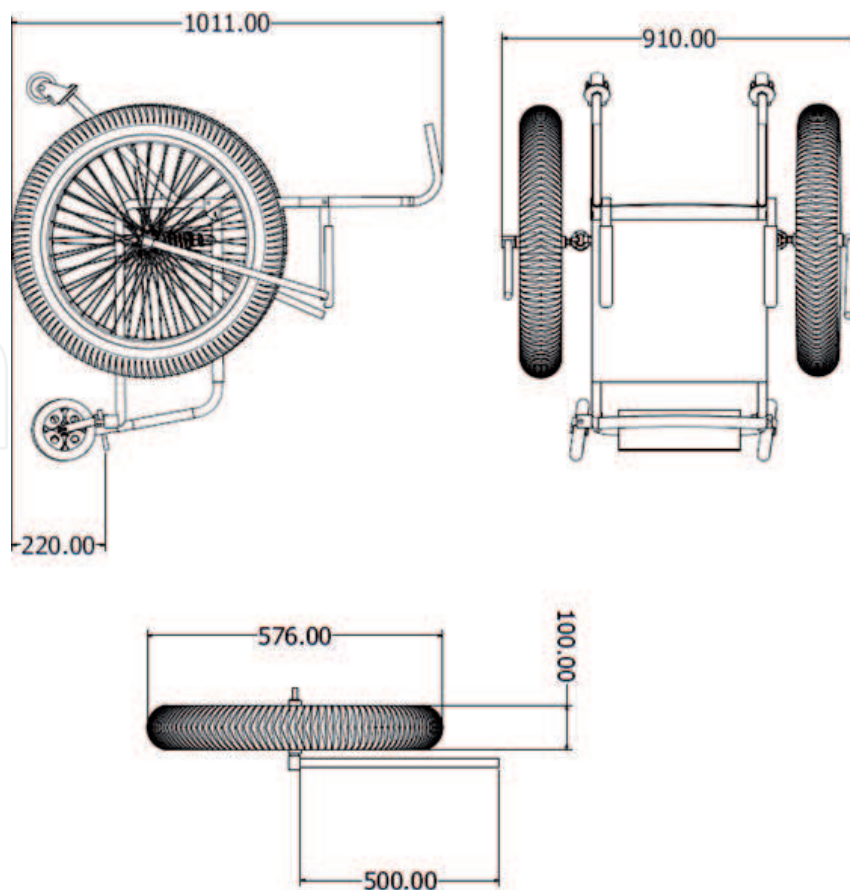


Figure 13. Side and top view of sized design, and the sized rear wheel.



**Figure 14.**  
*Final wide wheel design.*

If this results in a reaction on the fulcrum of 789.54 N, the force and bending moment distribution acting in the lever is described by the shear force diagram and bending moment diagram as shown below.

For a bending moment of 7922 Nm, the material for the lever, is designed to be mild steel selected from tables to be Fe 310 steel of tensile strength  $310 \text{ Nmm}^2$ , yield stress  $180 \text{ Nmm}^2$  and minimum elongation of 26.

Designing for a factor of safety of 3, the resulting allowable working stress is  $60 \text{ Nmm}^2$ .

## 6.8 Tipping angle

The widened rear wheels design was found that it could sustain a tipping angle of about 43.17 degrees from the calculations.

## 6.9 Designed wide rear wheels

**Figure 13** gives the sized views of the resulting design, as well as the recommended the rear wheel size.

The final 3D view of the resulting wheelchair is given by **Figure 14** below.

## 7. Economic analysis

Some costing was done for components that are going to be manufactured from workshop and others standardized components which are going to be bought. **Table 1** gives the major components the materials they would be made from.

The bill of quantities are given by **Table 2** as well as the costing of a prototype.

The cost of fabricating a prototype is estimated to be USD 186 including components cost and labor, which is within a maximum cap of USD200. This could vary depending on the manufacturer's requirements and specifications.

Component	Material
Wheelchair frame	Mild steel
Spring	Carbon steel
Ratchet bar	Mild steel
Seating material	Cotton
Rear wheel axle	Mild steel
Caster wheel bearing	Mild steel
Rear wheel rim	Mild steel
Footrest	Mild steel

**Table 1.**  
*Components and material specifications.*

Component	Quantity	Total cost (USD)
Frame	16 × 500 mm	30
Rear wheel	2	28
Caster wheels	4	16
Ratchet	2	32
Shock absorber	2	60
Labor	—	20
	Total	186

**Table 2.**  
*Bill of quantities.*

## 8. Recommendations

The wheelchair design is still limited when it comes to very steep inclines, in which case an incorporation of a motor to assist the hand effort will be required. There is also need to have adjustable rear wheels that can be pushed in or outwards from the chair so that it is not hindered when passing through narrow pathways of the rural terrain.

The operator has to always lock the brakes before getting in and out of the wheelchair. They have to also avoid putting heavy loads on the back of a wheelchair, as this may result in a shift in the position of center of gravity. This could cause the chair to tip over backwards.

The operator of the chair can keep it maintained by being knowledgeable about the wheelchair, and having a handy list of providers that one can rely on for repairs, parts, and maintenance. The user may not be able to perform the basic daily and weekly cleaning and upkeep but can set up a routine that can be followed by caregivers, family members or others to monitor the chair for problems. Assemble and store a set of tools that you will need to have on hand for maintenance and emergencies. There is need to keep the wheelchair clean to help keep the operator healthy and free of infections, this will also make it easier to identify equipment problems as they arise. The casters (front wheels) can present a safety hazard when they are worn out. One has to always check your casters for cracks in the spokes that may eventually cause the caster to collapse.

## 9. Conclusion

The chapter investigated the development of a rough terrain wheelchair design which is capable to withstand tipping angles up to 43.17 degrees, which is relatively

higher as compared to conventional wheelchairs. The wheelchair counters toppling in almost every direction due to the wide wheels and back caster wheels for anti-tipping. This wheelchair is intended to improve the mobility of those operators living in rural uneven terrain by reducing wheelchair related accidents. The incorporation of the spring shock absorber will also contribute to the comfortable sitting of the user. The overall cost of the design was estimated to be USD 186, if local raw materials are used for manufacturing of the wheelchair.

## Acknowledgements

We would like to thank the University of Zimbabwe (UZ), Mechanical Workshop team for working with this team of researchers in fabricating the prototype which gave the study a practical form result. We also acknowledge Danhiko Rehabilitation Centre for allowing us to access their facilities and also their input on wheelchair operator expectations. Also, we do really appreciate the solicited guidance offered by colleagues we work with at the University of Zimbabwe. Finally, we wish to thank all those who are implementing measures that help to protect the disabled from any injuries.

## Author details

Ignatio Madanhire\*, Loice Gudukeya and Roy Mushonga  
University of Zimbabwe, Harare, Zimbabwe

\*Address all correspondence to: [imadhanire@gmail.com](mailto:imadhanire@gmail.com)

## IntechOpen

© 2020 The Author(s). Licensee IntechOpen. This chapter is distributed under the terms of the Creative Commons Attribution License (<http://creativecommons.org/licenses/by/3.0>), which permits unrestricted use, distribution, and reproduction in any medium, provided the original work is properly cited. 



## References

- [1] Andrew M, Kwarciak MS. Determining the general considerations in needs and requirements of the wheelchair users from MHD and HHD countries. *Journal of Rehabilitation Research and Development*. 2014;**1**(2):1-2
- [2] Philipa C, Angela C. Fact sheet on wheelchairs. 2007;**1**:1-4
- [3] Winter A, Hotchkiss R, Durban M. Mechanical principles of wheelchair design. 2010
- [4] Forkenbrock DJ. Comparison of external costs of rail and truck freight transportation. *Transportation Research Part A: Policy and Practice*. 2001;**35**(4):321-337. DOI: 10.1016/S0965-8564(99)00061-0
- [5] Devillard X et al. Validation of a new ergometer adapted to all types of manual wheelchair. *European Journal of Applied Physiology*. 2005;**85**:479-485. DOI: 10.1007/s004210100407
- [6] Devillard X et al. Validation of a new ergometer adapted to all types of manual wheelchair. *World Health Organization*; 2001
- [7] Landerman LR, Shipp KM. Activity restriction among wheelchair users. *Journal of the American Geriatrics Society*. 2003:1244-1251
- [8] Chakwiriza J, Nhemachena C. Rural travel and disability in Leroro and Moremela Villages South Africa; 2010
- [9] Cooper RA, Cooper R, Boninger ML. Trends and Issues in Wheelchair Technologies. *Assistive Technology*. 2008;**20**(2):61-72
- [10] Db M. Guidance on the Stability of Wheelchairs BULLETIN, 2004(March); 2004
- [11] Jones ML, Sanford JA. People with mobility impairments in the United States today and in 2010. *Assistive Technology*. 1996;**8**(1):43-53
- [12] Di Marco A, Russell M, Masters M. In Practice Standards for Wheelchair Prescription. *Physical Medicine and Rehabilitation*; 2003. pp. 30-39
- [13] Wirth DA. The International Organization for Standardization: Private Voluntary Standards as Swords and Shields. *Massachusetts institute of Technology*; 2009. pp. 79-102
- [14] Adventures A. All-Terrain Wheelchair System; 2011
- [15] Rory A, Ken J, Stewart JK, David P, VanSickle DP. Evaluation of Methods for Determining Static Stability of Manual Wheelchairs. *Sacramento: California State University*; 2011
- [16] Trudel G et al. Effects of rear-wheel camber on wheelchair stability. *Archives of Physical Medicine and Rehabilitation*. 1997;**78**(January):78-81
- [17] Van der Woude L, Dallmeijer A, Janssen T. Alternative modes of manual wheelchair ambulation: An overview. *American Journal of Physical Medicine and Rehabilitation*. 2001b;**80**:765-777
- [18] Winter A. Mechanical Principle of Wheelchair Design. USA: Massachusetts Institute of Technology; 2010
- [19] Hill PEJ. United States Patent (19) 11 Patent Number: US. Patent June 27, 1995(19); 1995
- [20] Examiner A, Stabley MR, Chris A. (12) United States Patent (10) Patent No.: 1(12); 2011
- [21] Paquet V, Feathers D. An anthropometric study of manual and powered wheelchair users. *International Journal of Industrial Ergonomics*. 2004;**33**:191-204. DOI: 10.1016/j.ergon.2003.10.003