

We are IntechOpen, the world's leading publisher of Open Access books Built by scientists, for scientists

5,000

Open access books available

125,000

International authors and editors

140M

Downloads

Our authors are among the

154

Countries delivered to

TOP 1%

most cited scientists

12.2%

Contributors from top 500 universities



WEB OF SCIENCE™

Selection of our books indexed in the Book Citation Index
in Web of Science™ Core Collection (BKCI)

Interested in publishing with us?
Contact book.department@intechopen.com

Numbers displayed above are based on latest data collected.
For more information visit www.intechopen.com



Analysis and Development of Closed Cycle OTEC System

*Estela Cerezo Acevedo, Jessica G. Tobal Cupul,
Victor M. Romero Medina, Elda Gomez Barragan
and Miguel Angel Alatorre Mendieta*

Abstract

In this chapter, we present the methodology for the selection of the working fluid, the environmental and working conditions for operation, and the development carried out for the design of a closed cycle OTEC prototype plant. This prototype uses the temperature difference between the cooler deep waters and the warmer surface waters of the Mexican Caribbean Sea to feed a thermal machine capable of generating 1 kW of electrical energy; and it works with an organic Rankine cycle, composed of a pump, a turbine, and two heat exchangers. The advances carried out in installing the prototype are also presented.

Keywords: OTEC, working fluid, organic Rankine cycle, Mexican Caribbean Sea

1. Introduction

This chapter shows the design and progress of the installation of the first 1 kW_e OTEC prototype plant carried out in Mexico to be tested first at the laboratory level and then at potential thermal gradient sites in Mexico. Mexican Caribbean is a potential site because of its physical characteristics being a renewable energy deposit and a resource in Mexico that is located in an area of 98,000 km², with 825 km of littoral, corresponding to its exclusive economic zone (EEZ), adjoining the sea portions of the Republic of Cuba, Republic of Honduras, and Belize [1]. In the Caribbean Sea, as the surface temperature is very stable and the depth of 1000 m is not reached far from the coast, there are potential areas to install an OTEC plant in Cozumel Island, Punta Allen, Tulum, Sian Ka'an, Xcalak, Mahahual, and Chinchorro Bank [2]. It should be noted that all these areas meet the thermal gradients greater than or equal to 20°C and are located at 700 m depth and at a distance from the coast less than or equal to 10 km [3], as shown in **Figure 1**.



Figure 1. Potential sites in the Mexican Caribbean Sea. Source: Barcenas (2014).

2. Operation temperature conditions

To install an OTEC plant, its proximity to the land and a city must be considered.

2.1 Thermal potential of the Mexican Caribbean

In 2014, Barcenas mentions that the technically available power in the Mexican Caribbean is 2000 MWe, taking into account the potential OTEC locations shown in **Figure 1** with a thermal gradient of 20°C [2].

Analyzing the results of [2], we observe that the site in which an OTEC plant could be installed taking into account its proximity to land and a city is the island of Cozumel as the isobath of 700 m, closer to the coast, is located 4 km from the southeast coast of this island.

Another place where the installation of an OTEC plant would be very useful is in Punta Allen since it is a town that lacks electricity, drinking water, and sewage system, although the nearest isobath of 700 m is 9 km away from the coast.

2.2 Caribbean Sea temperature profiles

The key parameter is the temperature at different depths. In **Figure 2**, the annual average of the temperature gradient is shown. A minimum gradient in March (18.38°C) and a maximum in October (22.21°C) are observed.

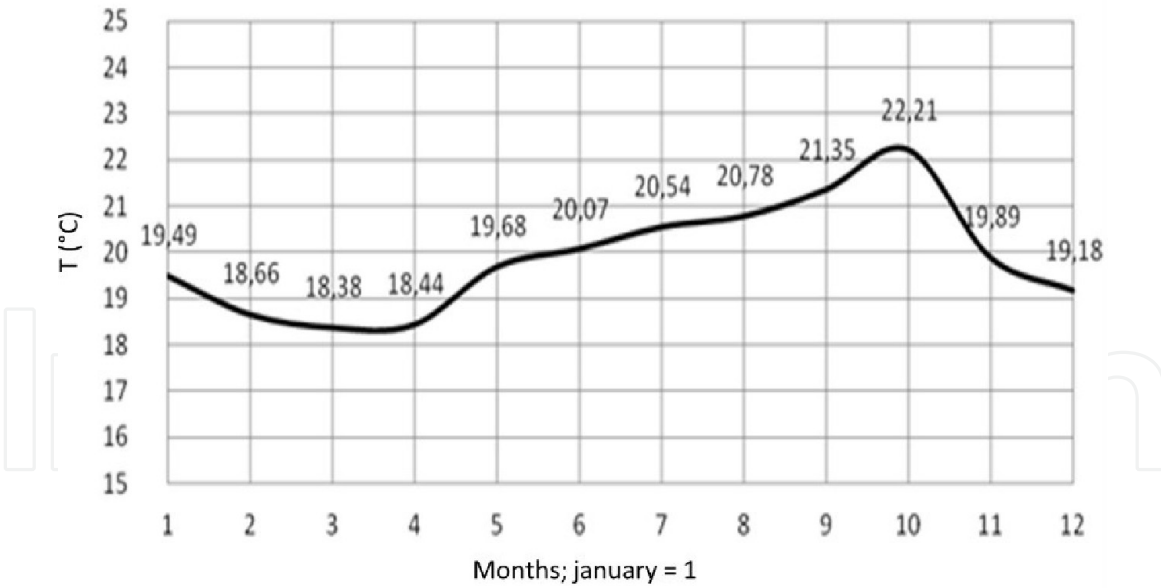

Figure 2.
Difference in temperature average between 0 and 1000 m. Source: Barcenas (2014).

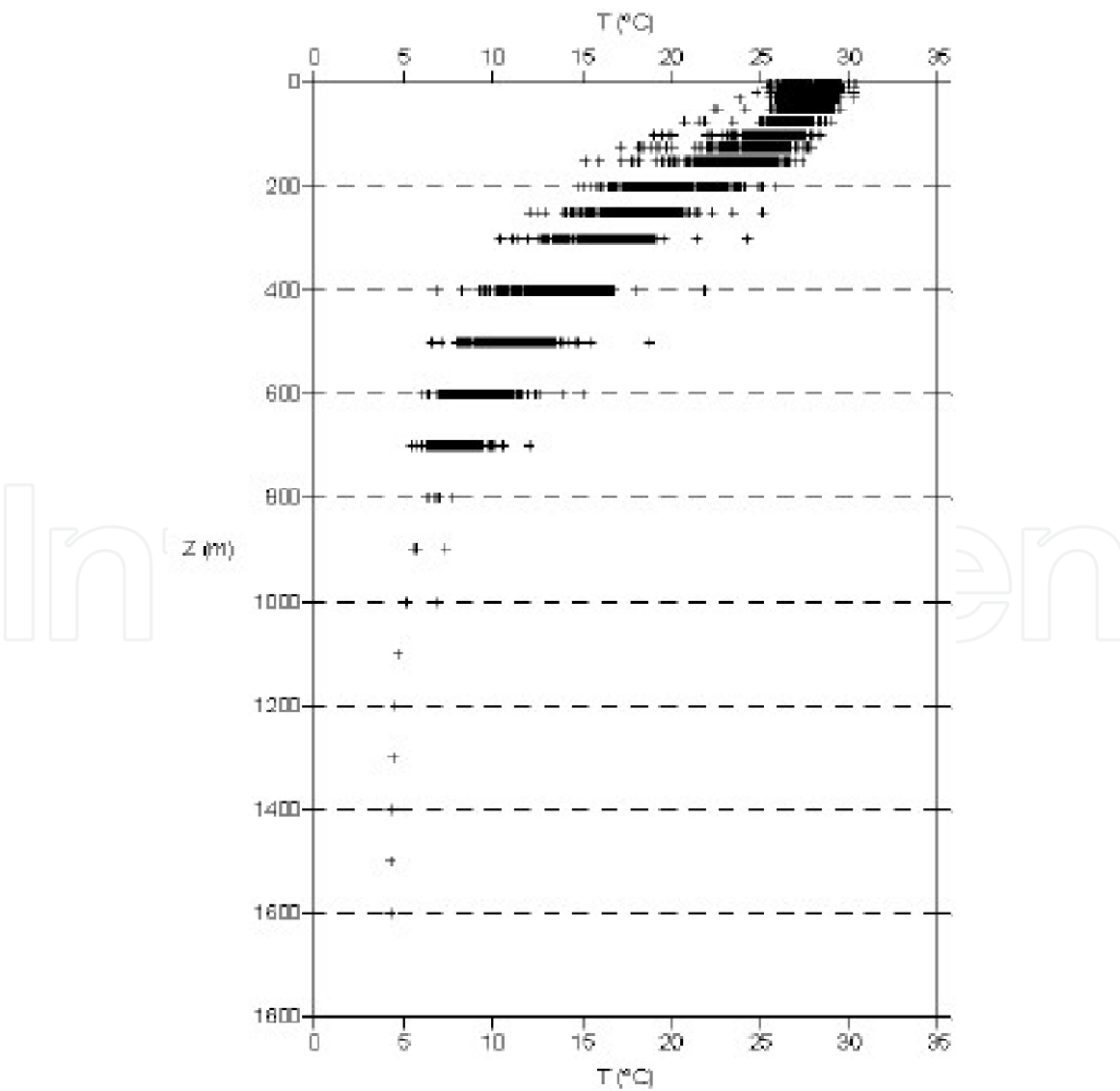

Figure 3.
Dispersion of Caribbean Sea temperatures with depth (latitudes 22°N to 17°N and -88.5°W and -84.5°W). Source: Barcenas (2014).

Barcenas (2014), based on the data collected to date by the National Oceanic and Atmospheric Administration, dispersed the temperature with respect to the depth for the Caribbean area (latitudes 22°N and 17°N and longitudes –88.5°W to –84.5°W). In **Figure 3**, we can observe this dispersion.

In the same reference, it is mentioned that the annual average is for the minimum temperature at 700 m of 7.69°C and the maximum surface is 27.46°C. Therefore, our initial temperature conditions will be minimum temperature 7°C and maximum temperature 27°C to overestimate.

3. Working fluid selection

The selection of the working fluid is of vital importance to achieve the maximum efficiency of the cycle in the OTEC plant, since the thermodynamic performance of the fluid has an impact on the size of the components of the plant and finally on the cost of the same [4].

In the following sections is described the methodology for selecting the working fluid in the OTEC-CC prototype plant that is being built at the University of the Caribbean according to different selection criteria.

3.1 Selection criteria

The working fluid is selected from commercial version of EES according to next criteria: (a) turbine and exchangers dimensions (φ and β); (b) environmental impact, ozone destruction potential (ODP) and global warming potential (GWP); and (c) safety (toxicity and flammability) and others (saturation pressure at 15.56° C and costs).

φ and β are defined as follows:

$$\varphi = \left(\frac{k^3 \rho^2 h_{lg}}{\mu} \right)^{1/4} \quad (1)$$

$$\beta = P_v \Delta h_{lg} M \quad (2)$$

where P_v is the saturation pressure at 15.59°C (kPa), h_{lg} is the evaporation enthalpy (kJ/kg), M is the molecular weight (kmol/kg), k is the liquid fluid thermal conductivity (W/m*K), ρ is the liquid density (kg/m³), and μ is the liquid dynamic viscosity (Pa*s).

φ is associated to the turbine diameter: if there is a maximum diameter, there is a minimum heat loss transfer to atmosphere. β is inversely proportional to mass flow, so the greater value of β can be found elsewhere [4, 5].

ODP is referred to ozone destruction capacity on stratosphere according to R11 ozone destruction capacity (which ODP = 1). GWP measures global warming potential according to carbon dioxide for 100 years [6]. For toxicity and flammability parameters, the occupational exposure limit (OEL) and the lower flammable limit (LFL) were investigated. OEL indicates the maximum amount that a person can be exposed for hours per week: a high value means low toxicity. LFL indicates the minimum amount of fluid concentration to be flammable in contact with the air: a high number means low flammability [6].

P_v was calculated on EES at 15.56°C, because 15.56°C is the evaporator's estimated phase change temperature. P_v relevance is because of the pressure effect cycle total efficiency; it could be required to attach a vacuum system or increase pump pressure [7].

The working fluid cost is in American Dollar. This represents an average fluid cost when there was more than one provider.

3.2 First selection of working fluid

ODP, GWP, and P_v are the parameters used as the first filter of the 50 fluids available in the EES program. On this phase those fluids that had any of the following characteristics were dismissed: (1) $ODP > 0$; (2) $GWP > 2500$ (according to European legislation, it is the same limit used for fixed refrigeration systems) [8]; and (3) P_v below atmospheric pressure (101.35 kPa) and greater than 1 MPa.

According to the first limit for P_v , if there would be a P_v lower than the atmospheric pressure, it would be necessary to make a vacuum to achieve fluid evaporation [9]. The second limit for P_v was determined to avoid creating a high pressure with the pump.

From this first selection of working fluids, the remaining were ammonia, isobutane, n-butane, propane, propylene, R134a, R152a, R407C, and R600a. These fluids were used for the next evaluations.

3.3 Evaluations

The evaluation of these nine remaining fluids was made using six parameters: GWP, OEL, LFL, φ , β , and the cost, as listed in **Table 1**. These were normalized in order to make a comparison with each other.

Each parameter has a different weight according to the importance that the parameter represents in the evaluation, and therefore there is a different weighting in each of them.

In this study, five weightings with specific weights for each parameter were considered, and each weighting corresponds to a specific work fluid selection objective.

3.4 Weightings and results

3.4.1 Weighting 1

Environmental impact and the cost of the fluid were considered the most important parameters, so 50% of the evaluation weight was divided equally for these parameters. Thirty-four percent of the evaluation weight was divided equally

Fluid	GWP	LFL (%)	OEL (PPMv)	φ	B	Cost(\$/kg)
Ammonia	1	16.7	25	10910.54	15224309.1	0.63
Isobutane	20	1.6	1000	18849.26	5193836.84	14.22
n-butane	20	2	1000	19411.61	3868581.12	0.06
Propane	20	2.1	1000	16321.13	11505975.77	18.59
Propylene	20	2.7	500	16605.01	13450526.52	2.49
R134a	1370	0	1000	34352.59	9443644.5	9.01
R152a	133	4.8	1000	25008.43	8558070.76	3.97
R407c	1700	0	1000	31875.68	12855787.83	10.44
R600a	20	1.6	1000	18612.92	5126886.38	14.22

Table 1.
Evaluated fluids.

between the parameters related to safety. The remaining 16% was divided among the other parameters (**Table 2**).

The results of this weighting are presented in **Table 3**, where it is shown that n-butane was the best fluid for this weighting with 69.69% effectiveness, followed by R152a with 68.45% and R134a with 63.71%.

3.4.2 Weighting 2

In this weighting scheme, the construction of an OTEC plant at the laboratory level was the main scenario to determine the weight of each parameter in the evaluation. Therefore 50% was directed to parameters related to safety, assigning 30% to toxicity and flammability with 20%. Then, 30% of the evaluation weight was divided equally between the environmental impact and the fluid cost. The remaining 20% was divided equally between the parameters referring to the size of the components of the OTEC plant (see **Table 4**).

Factor	Weight
GWP	0.25
<i>B</i>	0.08
Φ	0.08
Costs	0.25
Toxicity	0.17
Flammability	0.17

Table 2.
Weighting 1.

Fluid	Points (%)	Fluid	Points (%)
n-butane	69.69	R407C	58.48
R152a	68.45	Isobutane	51.26
R134a	63.71	R600a	51.13
Propylene	63.6	Propane	49.03
Ammoniac	59.84		

Table 3.
Results of weighting 1.

Factor	Weight
GWP	0.15
<i>B</i>	0.10
Φ	0.10
Costs	0.15
Toxicity	0.30
Flammability	0.20

Table 4.
Weighting 2.

In the **Table 5**, the results of this weighting are observed, with R134a being the fluid with the highest percentage, followed by R407C and R152a with 73.45 and 66.46%, respectively.

3.4.3 Weighting 3

The conviction that safety conditions could be controlled by taking appropriate measures during the OTEC prototype plant tests was the scenario considered for weighting 3 (see **Table 6**). Therefore, the safety parameters were considered 50% less important than the other parameters.

As a result of this weighting (see **Table 7**), R152a, R134a, and propylene fluids were the refrigerants that obtained the highest percentage, with respective values of 64.84, 64.04, and 63.87%.

Fluid	Points (%)	Fluid	Points (%)
R134a	75.58	Propylene	53.57
R407C	73.45	Isobutane	52.92
R152a	66.46	R600a	52.76
n-butane	63.54	Ammonia	42.61
Propane	53.97		

Table 5.
Results of weighting 2.

GWP	0.20
<i>B</i>	0.20
ϕ	0.20
Costs	0.20
Toxicity	0.10
Flammability	0.10

Table 6.
Weighting 3.

Fluid	Points (%)	Fluid	Points (%)
R152a	64.84	n-butane	57.07
R134a	64.04	Propane	42.89
Propylene	63.87	Isobutane	43.60
R407C	62.51	R600a	43.28
Ammonia	60.92		

Table 7.
Results of weighting 3.

3.4.4 Weighting 4

Considering all the equally important parameters was the objective of the weighting (see **Table 8**). Therefore, 100% of the evaluation weight was divided equally among the six parameters.

The results of **Table 9** showed R134a (with 70.04%), R407C (68.76%), and R152a (62.64%) as the fluids that best adapted to the weighting.

3.4.5 Weighting 5

For weighting 5 (of **Table 10**), the parameters referring to the OTEC plant equipment were considered the most important, so that 50% of the weight was divided equally into the value of ϕ and β . Then, another 40% was divided equally into the parameters related to environmental impact and safety; the latter has 10% for toxicity and flammability. Finally, the remaining 10% was allocated to the cost of the fluid.

Factor	Weight
GWP	0.16
B	0.16
ϕ	0.16
Costs	0.16
Toxicity	0.16
Flammability	0.16

Table 8.
Weighting 4.

Fluid	Points (%)	Fluid	Points (%)
R152a	64.84	n-butane	57.07
R134a	64.04	Propane	42.89
Propylene	63.87	Isobutane	43.60
R407C	62.51	R600a	43.28
Ammonia	60.92		

Table 9.
Results of the weighting 4.

Factor	Weight
GWP	0.20
B	0.25
ϕ	0.25
Costs	0.10
Toxicity	0.10
Flammability	0.10

Table 10.
Weighting 5.

Fluid	Points (%)	Fluid	Points (%)
R407C	66.54	Propane	52.41
R134a	66.33	n-butane	48.88
R152a	62.02	Isobutane	43.52
Propylene	60.62	R600a	43.12
Ammonia	56.23		

Table 11.
Results of weighting 5.

Position	Weighting 1	Weighting 2	Weighting 3	Weighting 4	Weighting 5
1	n-butane	R134a	R152a	R134a	R407C
2	R152a	R407C	R134a	R407C	R134a
3	R134a	R152a	Propylene	R152a	R152a

Table 12.
Frequency of the first three positions in evaluations.

The fluids R407C, R134a, and R152a were the ones that best suited the weighting, according to the evaluation results (see **Table 11**).

3.5 Selected fluid

The summary of evaluations is given in **Table 12**, where it is shown that R134a, R152a, and R407C were the fluids that had the highest frequency along the different weightings. The R134a appeared in one of the first three positions in all evaluations and obtained the first position in 2/5 evaluations, the second position in 2/5 evaluations, and the third position in 1/5 evaluations. R152a also appeared in one of the first three positions in all the evaluations and obtained the first position in 1/5 evaluations, the second position in 1/5 evaluations, and the third position in 3/5 evaluations. Finally, the R407C did not appear in 2/5 evaluations; however, it obtained the first position in one evaluation and the second position in the two remaining evaluations.

Finally, R152a (1,1-difluoroethane, $C_2F_2H_4$) was selected for the OTEC-CC prototype plant, since the laboratory conditions will be controlled throughout the process. The working fluid was evaluated under ideal Rankine cycle with temperatures of hot and cold source of 27 and 7°C, respectively, obtaining the thermal efficiency (η_T) of 3.445%.

4. A 1 kWe CC-OTEC prototype plant

The main components in this prototype are the evaporator, condenser, turbine, and pump; a steam separator and a tank are also included. For the prototype to be tested in the laboratory, heating and cooling systems are included, as shown in **Figure 4**. All the components relate to each other using pipes and valves. R-152a at compressed liquid state is transported by the pump to the evaporator, where the working fluid is evaporated into a saturated vapor state by warm water from the heating system. The vapor of the working fluid passes through the steam separator to prevent liquid to enter to the turbine, and it could damage the blades. Then the

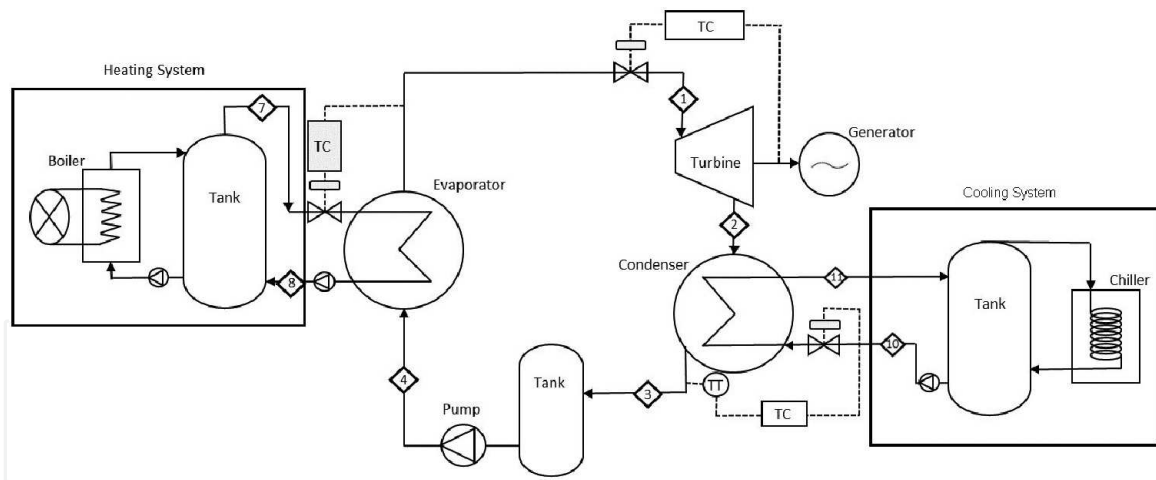

Figure 4.
Closed cycle OTEC prototype plant.

vapor drives the turbine and the connected electrical generator to produce 1 kW of electricity. The mixture vapor from the turbine is cooled into a saturated liquid state by the cool water in the condenser, and then the saturated liquid of the working fluid is transported by the pump to the evaporator to close the cycle. However, because of the small temperature difference between the warm water and cool water, the thermal efficiency of prototype OTEC plant is very low, about 3%. The balances of mass and energy were made for the diagram of **Figure 4**.

The heat added in kJ/kg (q_e) is

$$q_e = h_1 - h_4 \quad (3)$$

where \dot{m} is mass flow and h is the enthalpy at the indicated state point. The turbine's real work in kJ/kg (w_{Tr}) is

$$w_{Tr} = h_1 - h_{2r} \quad (4)$$

where

$$h_{2r} = h_1 - \eta_T(h_1 - h_{2s}) \quad (5)$$

and η_T is the turbine efficiency, h_{3r} is the real enthalpy, and h_{3s} is the isentropic enthalpy.

The heat rejected in kJ/kg (q_c) is

$$q_c = h_2 - h_3 \quad (6)$$

and the pump work is

$$w_p = h_4 - h_3 \quad (7)$$

4.1 Carnot efficiency

It is the maximum efficiency that this system can have that will operate between two thermal energy deposits at temperatures $T_L = 280.2$ K and $T_H = 300.3$ K.

$$\eta_{carnot} = \left(1 - \frac{T_L}{T_H}\right) 100 \quad (8)$$

Parameter	
η_{Carnot}	6.7%
η_{th}	2.4%
X	0.99
Q_e	45.31 kW
Q_c	44.20 kW
W_p	0.017 kW
W_t	1.11 kW

Table 13.
Heat and mass balance for 1 kWe prototype plant.

Parameter	Unit	R152a					Water			
		1	2	3	4	7	8	9	10	
Temperature	°C	22.5	22.5	12	11.61	27	23	7	10	
Pressure	MPa	0.55	0.55	0.4	0.39	0.13	0.1	0.11	0.1	
Mass flow	kg/s	0.15	0.15	0.15	0.15	2.71	2.71	3.51	3.51	

Table 14.
Flow mass results.

The real efficiency of this system is

$$\eta_{th} = 1 - \frac{q_c}{q_e} \quad (9)$$

The results of the heat and mass balance are presented in **Table 13**.

The thermodynamic evaluations were carried out with the EES program.

The results of mass flow of the working fluids and intake seawater flow for the evaporator and condenser are presented in **Table 14**. 2.71 kg/s of surface seawater at 27°C and 3.51 kg/s of deep seawater at 7°C are necessary in this prototype.

5. Advances of the installation of the OTEC prototype plant

This section describes the progress of the installation of the OTEC prototype plant to generate 1 kWe, which will be tested in the laboratory and later the sites of interest in Mexico.

5.1 Pipe sizing

Once the mass and energy balances were made, the sizing of the pipe diameters (ϕ_t) was carried out based on the mass flow equation (Eq. 12), which is a physical quantity that expresses the variation of mass with respect to time in a specific area (A_T).

$$\dot{m} = \rho v A_T \quad (10)$$

where

$$A_T = \frac{\pi \phi_t^2}{4} \quad (11)$$

and

$$\phi_t = \sqrt{\frac{4\dot{m}}{\rho v \pi}} \quad (12)$$

In all cases, the calculation for pipe diameter size was made in mm, and subsequently the result was adjusted to the immediate higher pipe diameter size for commercial pipes. For example, if $\phi_t = 210$ mm, around 0.82 in, a commercial pipe of 1 in of diameter was selected.

In the case of the pipe for the liquid refrigerant, a speed of 1.5 m/s was considered. For the refrigerant in gaseous state a speed of 20 m/s (Table 15).

5.2 Installation

The installation of the OTEC prototype plant was carried out based on Figure 4. The storage tank (1100 L) of the cooling system was connected with the plate condenser (Line 10 and 11 of Figure 4) by a PVC pipeline Schedule 40 with a nominal diameter of 1½".

To connect the storage tank of the heating system (1100 L) with the plate evaporator and a ¾ HP surface pump (lines 7 and 8, Figure 4), PVC pipeline 40 of 1½" and heavy duty 2 × 12 cable were used. Rheem 89V40 electric heater was connected to storage tank with PVC pipeline 40 of ¾" (hydraulic line) and to a 220 V socket with heavy duty 3 × 12 cable (electrical line).

To complete the installation of the OTEC prototype plant (Figure 5), the turbine and the working fluid pump must be connected. The turbine was designed because

Dates	R152a						Water			
Line	1	2	3	4	5	6	7	8	9	10
Diameter (in)	°C	1	1	1	0.5	0.5	1.5	1.5	1.5	1.5
Materials	Cu						PVC			

Table 15.
Pipe diameter and materials.

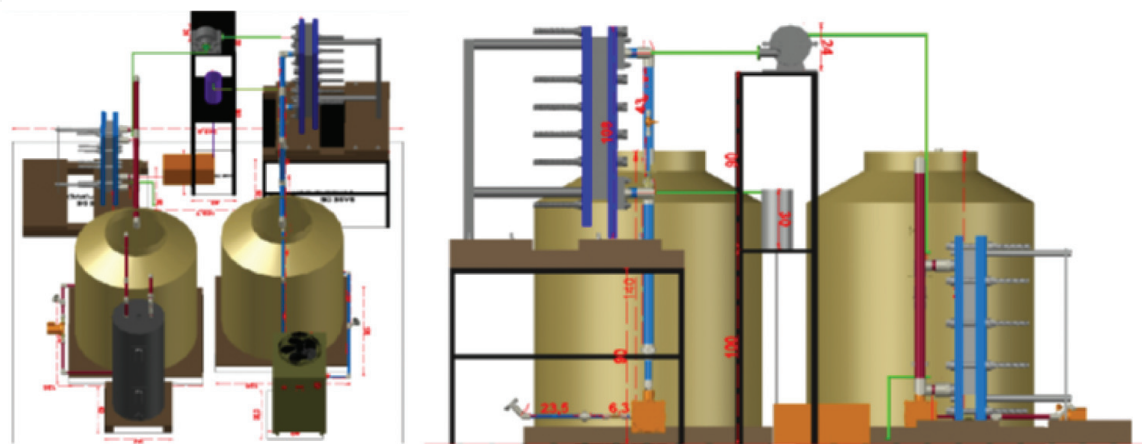

Figure 5.
3D prototype installation diagram.

there is no commercial turbine with the characteristics of the project and at the moment it is in manufacturing process.

6. Conclusions

According to the temperature profile of the Mexican Caribbean Sea, it was determined that the temperatures for the operating conditions are 27 and 7°C for surface seawater and 700 m depth, respectively. A closed cycle OTEC system was also selected for the expected dimensions of the turbine-electric generator, and according to the assigned weights, the best working fluid was R-152a, being compatible with copper, pipe material, and equipment that are planned to be used.

As expected, the maximum efficiency is low ($\eta = 6.7\%$) since the difference in temperature between the heat source and the heat sink is small ($\Delta T = 20^\circ\text{C}$); therefore, the effective thermal efficiency will be much lower ($\eta = 2.4\%$) than the other plants that use the Rankine cycle, such as thermoelectric plants; however, it should be noted that fossil fuels are not consumed and the source of heat is free and inexhaustible. Likewise, it was observed that only 2% of the power produced by the generator would be used to power the pump.

Up to now, the heating and cooling systems have been installed; we continue working on the installation and testing of the OTEC prototype plant.

Acknowledgements

This work was financially supported by the Mexican Centre of Innovation in Ocean Energy supported by the National Council for Science and Technology and the Mexican Secretariat of Energy.

Author details

Estela Cerezo Acevedo^{1*}, Jessica G. Tobal Cupul¹, Victor M. Romero Medina¹, Elda Gomez Barragan² and Miguel Angel Alatorre Mendieta³

¹ Department of Basic Sciences and Engineering, University of Caribe, Cancun, Quintana Roo, Mexico

² Academy of Environmental Engineering, Mountain Technological Institute, Tlapa de Comonfort, Guerrero, Mexico

³ Institute of Marine Sciences and Limnology, National Autonomous University of Mexico, Mexico City, Mexico

*Address all correspondence to: ecerezo@ucaribe.edu.mx

IntechOpen

© 2020 The Author(s). Licensee IntechOpen. This chapter is distributed under the terms Commons Attribution - NonCommercial 4.0 License (<https://creativecommons.org/licenses/by-nc/4.0/>), which permits use, distribution and reproduction for non-commercial purposes, provided the original is properly cited. 

References

- [1] Bárcenas J. El mar Caribe de México y su potencial energético renovable. Cuba: Memorias IX Congreso Internacional de Ciencias del; 2012
- [2] Bárcenas J. Evaluación del potencial energético renovable del Caribe Mexicano. México, D.F., México: Instituto de Ciencias del Mar y Limnología; 2014
- [3] Garduño E et al. Conversión de Energía Térmica Oceánica (OTEC) Estado del Arte. Cemie-Océano: Universidad Autónoma de Campeche; 2017
- [4] Yoon J-I et al. Efficiency comparison of subcritical OTEC power cycle using various working fluids. *Heat and Mass Transfer*. 2014;**50**:985-996
- [5] Avery WH, Wu C. Renewable Energy from the Ocean: A Guide to OTEC. New York, Oxford: Oxford University Press; 1994
- [6] Bernal M. Estudio técnico y económico de una planta OTEC y sus usos secundarios en México. (Tesis de maestría). Ciudad de México: Universidad Nacional Autónoma de México; 2016
- [7] Calm JM, Hourahan GC. Physical, safety, and environmental data for current and alternative refrigerants. In: *Proceedings of 23rd International Congress of Refrigeration (ICR2011)*; Prague, Czech Republic: s.n.; August 2011. pp. 21-26
- [8] Domanski PA. Evolution of refrigerant application. *International Congress of Refrigeration*. 1999;**4**:131
- [9] REGLAMENTO (UE) N° 517/2014 del Parlamento Europeo y del Consejo, de 16 de abril de 2014, sobre los gases fluorados de efecto invernadero y por el que se deroga el Reglamento (CE) N° 842/2006. Unión Europea. s.l.: Diario Oficial de la Unión Europea