

Field Programmable Gate Array-based Readout for Surface Acoustic Wave Portable Gas Detector

Fahim Durani^{#,@}, Mainuddin^{*,*}, U. Mittal[#], J. Kumar[#], D. Barlewar[#], and A.T. Nimal[#]

[#]DRDO-Solid State Physics Laboratory, Delhi - 110 054, India

[@]Department of ECE, Jamia Millia Islamia University, Delhi - 110 025, India

^{*}E-mail: mainuddin@jmi.ac.in

ABSTRACT

Surface acoustic wave (SAW) is one of the most promising technology in the field of gas sensing at low concentrations. Field deployable portable SAW detectors are, however, prone to noise, there by limiting the detection at low concentrations. To meet the current requirements of gas detection at low concentrations, the readout methodology needs to be based on minimal hardware and better noise management. In this paper we describe a readout scheme for portable SAW gas detectors incorporating a field programmable gate array (FPGA). The developed readout system includes a modified reciprocal frequency counter for differential SAW sensor, median noise filtering and moving averages smoothing for noise management, peak detection and interfacing with external display, all implemented in FPGA. The developed readout was tested against VOCs using a lab developed vapour generator and the results have been presented in the paper. The readout system is compact, low power consuming and expandable through software thus ideal for portable handheld applications..

Keywords: Surface acoustic wave; FPGA; Oscillator; Readout; Median filter; Smoothing;

1. INTRODUCTION

Surface acoustic wave (SAW) vapour sensors are well recognised for their high sensitivity, reversibility, quick response, reliability and low cost¹⁻⁴. Extensive work has been done in the past to realise SAW based systems for detection of volatile organic compounds (VOCs)^{5,6}, humidity⁷, wine⁸, NO₂⁹, chemical warfare agents¹⁰, hydrogen¹¹, SO₂, NH₃, H₂S¹², odour¹³ and air quality¹⁴. All these applications justify a sustained demand for development of SAW based portable detector systems. One reason for the detectors being bulky in size is the complexity of the readout and control electronic circuits¹⁵. The approaches commonly used are either lab instrument based or discrete electronic component based. The former approach uses large sized equipment like spectrum or network analysers while the later approach comprises of multiple discrete components like counters, digital logic ICs, multiplexers and microcontrollers¹⁶⁻¹⁸.

This paper presents FPGA based SAW sensor readout. A high resolution reciprocal frequency counter, impulse noise removal, smoothing, peak detection, display interface and PC interface have been implemented in FPGA.

2. SAW VAPOUR DETECTOR

SAW vapour detector essentially consists of an air sampler, gas flow controllers, SAW sensor and electronic readout and control. For gas sensing application SAW delay line, resonator, filter or dispersive delay line can be used¹⁹. For this work a commercial one port 433.92 MHz SAW resonator

(RFM RO3101, TO39 package) has been used. As it is known that adsorption of mass (from gas/vapor molecules) results in change in SAW parameters like phase and attenuation. The variation SAW parameters can be measured as frequency change by connecting SAW device in the feedback path of the RF amplifier thus forming an oscillator²⁰. For this work the device is configured as a Colpitt oscillator due to its better SNR²¹. The schematic diagram of SAW Colpitt oscillator used is shown in Fig. 1. SAW is also sensitive to changes in physical variables like temperature, vibrations, stress and hence, to minimize the effect of such fluctuations, dual device sensing mode is employed²²⁻²⁴. The differential frequency $\Delta f = f_0 - f_s$,

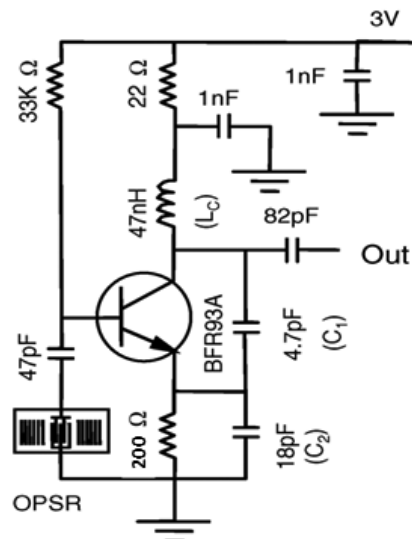

Figure 1. SAW colpitt oscillator circuit.

f_s and f_0 are the absolute frequencies of sensing SAW device and reference device respectively. The differential mode also makes the readout easier by bring down output frequency from MHz to KHz range. The package of the sensing device is opened from the top to expose the device while the reference is kept closed. The output from both oscillators is mixed in a mixer IC (BGA 2022). A differential output signal of around hundred KHz is obtained from the mixer which serves as a baseline. The block diagram and complete circuit board having both oscillators and mixer is shown in Fig. 2.

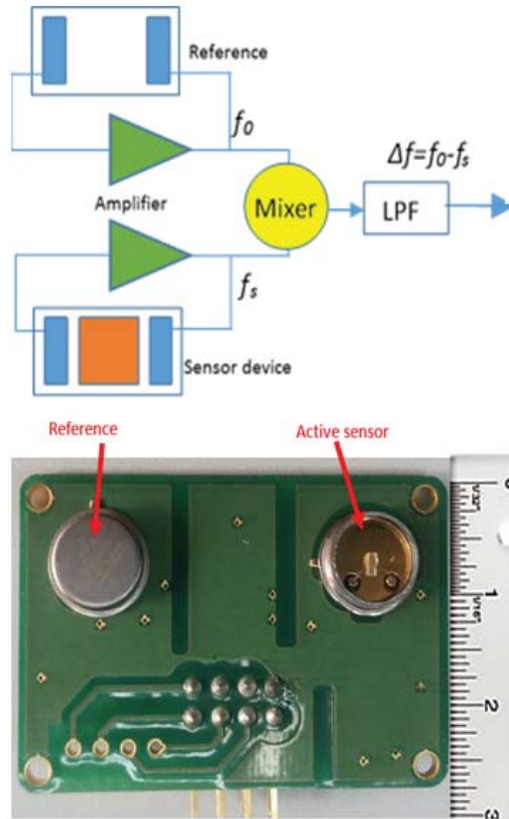

Figure 2. Block diagram and sensor circuit board.

3. FPGA READOUT AND PROCESSING

Field programmable gate array (FPGAs) devices are reconfigurable platforms for building digital hardware. They integrate the advantages of parallelism in hardware and programmability through software. FPGAs consist of predesigned elementary units and programmable interconnects enabling the end user to design specific digital hardware²⁵. Thus, these provide excellent low-cost and high performance resource for design exploration and even in final prototyping²⁶. FPGAs also enable us lateron convert the design into ASIC (application specific IC)²⁷. Low power consumption, reconfigurable (flexible) logic, large number of I/Os, on-chip PLLs & ADC (in some cases) and short development cycle make FPGAs highly suitable for portable/handheld applications. Being a single IC, FPGA also offers advantages compared to multiple IC based circuits which are plagued by noise due to interference through interconnecting paths, stray capacitances and feedback through air²⁸.

For this work, Microsemi Fusion FPGA AFS600PQ208 was used. It is a mixed signal FPGA with inbuilt ADC, RAM and Flash memory. Microsemi FPGAs are flash based with low power consumption²⁹. The readout is powered by a 3.7 v Li-Ion battery drawing less than 100 mA.

For detection of chemical vapours, the differential frequency signal from sensor circuitry is to be acquired, processed, analysed and outcome communicated in terms of audio/visual alarm. This part of the circuitry was implemented in FPGA. This includes frequency counter, impulse noise filter, data smoothing, peak detection, OLED interfacing and PC interfacing. The software design, synthesis and simulation, place-and-route, timing and power analysis, debugging and programming was done using Microsemi Libero Integrated Development Environment.

3.1 Frequency Counter

Frequency counting is the first step in SAW readout. For sensing application, a fast counting method with decent resolution is required. Among the established frequency counting techniques, reciprocal counting is best suited for SAW application due to following two reasons. One, it is fast and has better resolution compared to direct counting technique. Secondly, compared to the techniques based on regression and extrapolation, the reciprocal frequency count is an averaged value of input frequency and hence absorbs the distributed noise due to oscillator fluctuations.

Reciprocal frequency counter measures time period of a signal over an integral number of input cycles and frequency is then computed by the division of number of cycles by time interval providing very high resolution^{21,30}. Time period (t) of signal is, therefore, determined using time period (T) of a reference signal²². The time period (and hence the frequency) thus obtained is the average value of (n) input cycles with an accuracy of $\pm T$ (if synchronised at the start). The frequency is calculated as a reciprocal of time period Eqn. (1).

$$t = N * \frac{T}{n} \tag{1}$$

It is important to understand here that the accuracy of measurement is dependent on the stability and accuracy of reference clock. For the present work a 100 MHz crystal oscillator with ± 25 ppm stability over a wide temperature range was used as reference.

The reciprocal frequency counter was implemented in FPGA by using two counters for counting number of input counts (n) and reference counts (N). The number of bits of counters has direct bearing on the speed and resolution of measurement. Higher resolution with increased bits comes at a cost of speed of measurement. For a varying input frequency (from differential oscillator), number of counter bits vary and hence an automatic range selector (coordinator) has been implemented to cater to it as shown in block diagram Fig. 3. The coordinator monitors the number n of input counter and based on this adjusts the gate time. In order to achieve uniform resolution and speed, n is less for smaller frequencies and high for higher frequencies. The auto ranging reciprocal frequency counter implemented has been patented vide Patent design no.

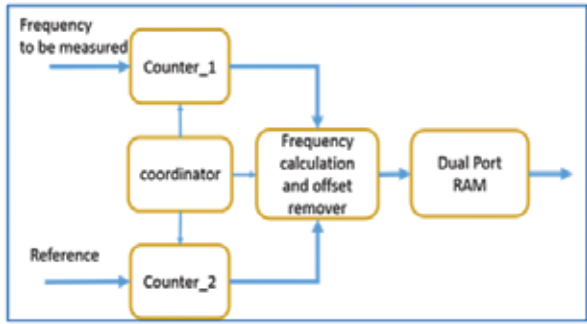

Figure 3. Block diagram of frequency counter.

252073. The frequency values are stored in a dual port RAM built inside the FPGA.

3.2 Impulse Noise Removal using Median Filtering

The frequency values obtained were found to contain occasional sharp and sudden jumps usually termed as impulse or spike noise. This single point noise was observed at random locations and with random frequency of occurrence. The presence of spike noise is attributed to extraneous noise generated by vibration, noise from sampling pump and dc-dc power supply switching noise. The detection and removal of these points is critical as they can be mistaken as genuine peaks and can result in false positive alarms.

Median filtering has been implemented for removal of Impulse noise. It is considered good for removal of impulse noise³¹. In this method, the noise value is replaced by the median of appropriate window³². The first step is to identify the impulse noise value and then obtain the median and finally replace the value. For single point impulse noise, a minimum 3 point window is required for median filtering. If data contains double (2 consecutive) impulse points then 5 point window is required. Since our data contains only single point impulse noise thus only 3 point window has been implemented. The identification of impulse point is done by calculating density D value and comparing with a threshold. Three data points are fetched from RAM and extend of middle point from first and third point form the density. Let $f(t_1-1)$, $f(t_1)$ and $f(t_1+1)$ be the three consecutive frequency values. The density D is calculated by Eqn. (2) as below.

$$D = \{f(t_1) - f(t_1 - 1)\} + \{f(t_1) - f(t_1 + 1)\} \\ = 2 * f(t_1) - [f(t_1 - 1) + f(t_1 + 1)] \quad (2)$$

D values above threshold are taken as impulse noise and $f(t)$ is replaced by the median of $f(t-1)$, $f(t)$ and $f(t+1)$. The three data values are arranged using bubble sorting with middle point being the median.

3.3 Smoothing

In addition to impulse noise the sensor data also has distributed noise. The average variation in sensor data was found to be around 50 Hz. To make the data smooth and arrest small frequency excursions moving averages method has been implemented. Moving averages is an effective way of smoothing random data fluctuations^{33,34}. Each data point $f(t_j)$ is replaced by average of m data points as calculated by Eqn. (3).

$$f(t_j) = \frac{1}{m} \sum_{t_i = \frac{m}{2}}^{\frac{m-1}{2}} f(t_i) \quad (3)$$

The averaging was performed for $m = 8, 16, 32$ and 64 points. As averaging is increased, data becomes smoother but the peak values also decrease. Thus $m = 16$ was taken as an optimised value.

3.4 Peak Detection

Detecting peaks is one of the major steps in the detection analysis³⁵. In the absence of target vapour, a baseline frequency output is produced. However, when the sensor is exposed to target vapour, peaks are produced in the signal. The presence of signal peaks above the noise base is an indication of sensor detection. Thus peak detection is very critical. The algorithm for peak detection has been developed using threshold method. When the signal increases beyond a positive threshold and again when it falls below a negative threshold, a peak is registered. The developed algorithm is easily extendable to window-threshold technique for future use of gas chromatography for time separated simultaneous detection of multiple vapours.

3.5 Display and PC Interfacing

Organic light emitting diode (OLED) display has been interfaced with FPGA for real time plot of sensor data. This will enable a handheld detection system. 128x64 yellow Densitron OLED has been used. The system can also be interfaced with PC through serial port. 14 bit data along with time information is send through UART port at 19200 baud rate. A software for display and storage of data on PC has been written in VB.net.

4. VAPOUR GENERATOR AND EXPERIMENTAL SETUP

A vapour generation and delivery system as shown in Fig. 4 was developed to test and verify the readout. It consists of three flow controllers (F1, F2 and F3), three solenoid valves (V1, V2 and V3) and a corrugated glass tube. The corrugated glass tube with controlled heating arrangement is filled with a small quantity of target agent (in liquid form) for precise concentration generation. A carrier gas is continuously passed through its head space and is split into three paths, controlled by individual flow controllers, the first one carries the target gas (F1), the second one carries the carrier (F2) and the third is the dilution line (F3). Nitrogen gas (N_2) was used as the carrier and was supplied from a Nitrogen generator.

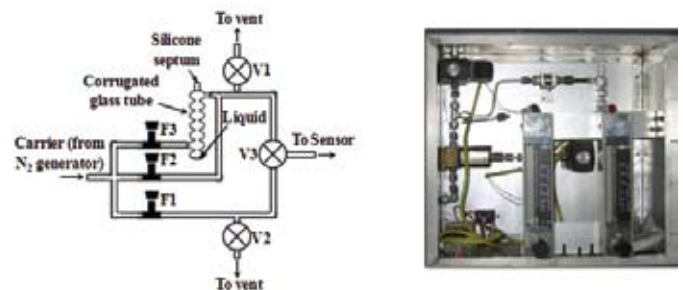

Figure 4. Schematic of vapour generator and vapour generator system.

A fixed value flow rate (100 ml/min) was maintained at the output. There are two paths to the SAW sensor – carrier and carrier with target vapours. In order to open either of the two paths, the three solenoid valves were used. While V3 is a 3-way valve, V1 and V2 are 2-way valves. To avoid excess pressure buildup when one path is closed, the corresponding vent valve is simultaneously opened. The switching time of valves is in milliseconds for seamless flow of gases along the two paths with negligible flow disturbance during the switching of the valves. A stainless steel sensor cell was fabricated and the sensor board containing SAW sensor is placed within the cell as shown in Fig. 5.

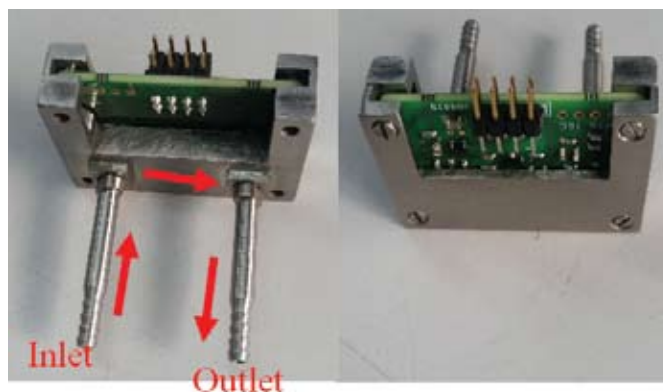

Figure 5. Sensor cell along with circuit board.

5. RESULTS AND DISCUSSION

To carry out the testing, initially carrier gas is passed at a constant flow rate (100 cc/min) to obtain a baseline. Next the vapours of 2-chloroethyl ethyl sulfide (CEES), a simulant of deadly chemical warfare agent Sulfur Mustard, were generated and passed through the inlet tube of sensor cell. The vapours flow over the sensor and exit the cell through the outlet tube. As the vapours were introduced along with carrier gas the differential frequency output from the sensor cell began to increase and returned to base value after vapour is stopped thus forming clear peaks as shown in Fig. 6. The height of peak is an indication of concentration. The data was found to be smooth and without Impulse noise. Subsequently, concentration of CEES was varied in steps and response studied. The results are shown in Fig. 7. The generated concentrations were verified by GC-MS (Perkin-Almer make). Table 1 shows the noise and peak height at different concentrations.

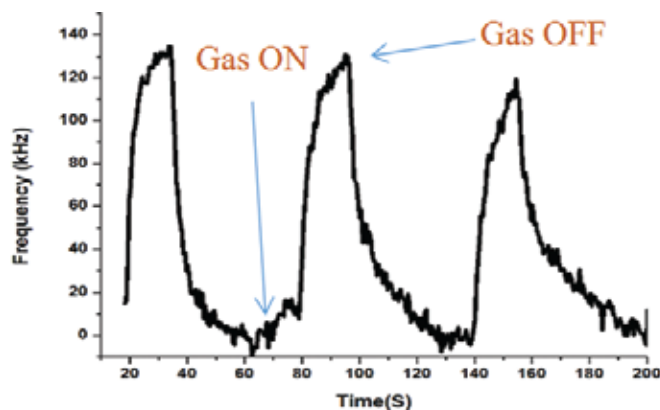

Figure 6. Plot showing frequency versus time for CEES.

Table 1. Showing sensor response and noise at various concentrations of 2-Chloroethyl Ethyl Sulfide (CEES).

Conc. (ppm)	Noise (Hz)	Peak height (Hz)
2.0	14	3492
1.0	15	1555
0.6	12	733
0.4	11	350
0.35	13	264
0.3	12	165

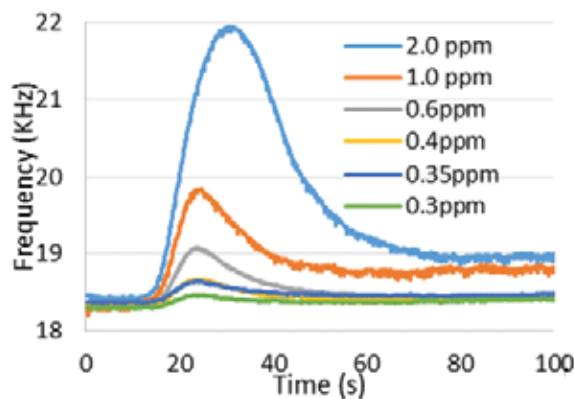

Figure 7. Sensor response at different concentrations of CEES.

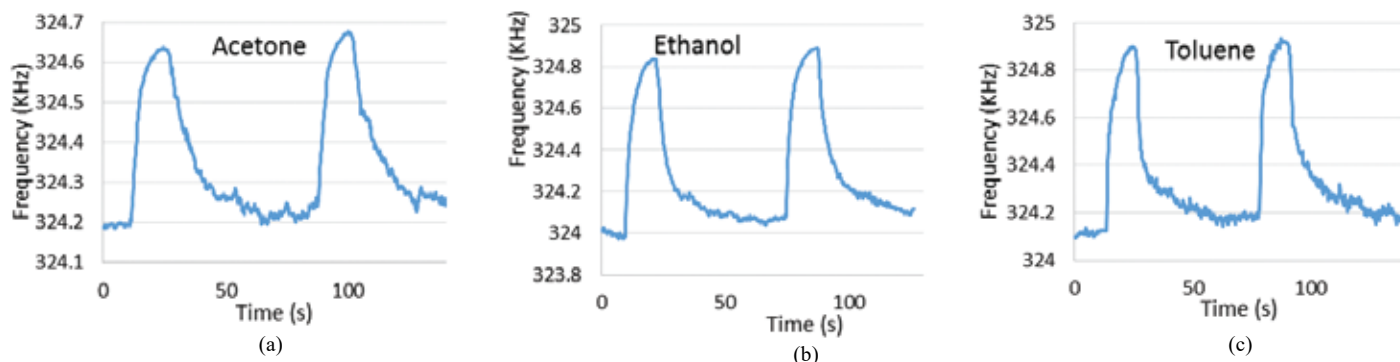

Figure 8. (a) Sensor response for Acetone at 0.5 ppm conc, (b) Sensor response for Ethanol at 0.5 ppm conc, and (c) Sensor response for Toluene at 0.5 ppm conc.

The experiment was repeated for VOCs like Acetone, Ethanol and Toluene as shown in Figs. 8(a), 8(b), and 8(c) respectively.

6. CONCLUSIONS

The FPGA based readout for portable SAW gas detector presented is a complete set of hardware and software. It allows to acquire frequency values from sensor, filter out noise from it, analyse and communicate the outcome. The minimalist hardware is used for readout for realizing a portable gas detector.

The developed readout was tested against CWA simulant CEES and VOCs and the results have been presented here. Although the readout was tested for a single differential SAW sensor, the same readout hardware can be used for multi-sensor approach called e-nose.

REFERENCES

- Jakubik, W.; Powroznik, P.; Wrotniak, J. & Krzywiecki, M. Theoretical analysis of acoustoelectrical sensitivity in SAW gas sensors with single and bi-layer structures. *Sens. Actuators B, Chem.*, 2016, **236**, 1069-1074. doi: 10.1016/j.snb.2016.05.157
- Lim, Chunbae; Wang, Wen; Yang, Sangsik & Lee, Keekeun. Development of SAW-based multi-gas sensor for simultaneous detection of CO₂ and NO₂. *Sens. Actuators B, Chem.*, 2011, **154**, 9–16. doi: 10.1016/j.snb.2010.02.057
- Shen, Chi-Yen; Huang, Chun-Pu & Huang, Wang-Tsung. Gas-detecting properties of surface acoustic wave ammonia sensors. *Sens. Actuators B, Chem.*, 2004, **101**, 1–7. doi: 10.1016/j.snb.2003.07.016
- Wolff, Ulrich; Dickert, Franz Ludwig; Fischerauer, Gerhard K.; Greibl, Wolfgang & Ruppel, Clemens C. W. SAW sensors for harsh environments. *IEEE Sensors J.*, 2001, **1**(1), 4-13. doi: 10.1109/JSEN.2001.923583
- Fang, Ming; Vetelino, Kevin; Rothery, Michael; Hines, Jacqueline & Frye, Gregory C. Detection of organic chemicals by SAW sensor array. *Sens. Actuators B, Chem.*, 1999, **56**, 155–157. doi:10.1016/S0925-4005(99)00176-8
- Rapp, M.; Reibel, J.; Voigt, A.; Balzer, M. & Bulow, O. New miniaturized SAW-sensor array for organic gas detection driven by multiplexed oscillators. *Sens. Actuators : B, Chem.*, 2000, **65**, 169–172. doi:10.1016/S0925-4005(99)00321-4
- Tashtoush, N.M.; Cheeke, J.D.N. & Eddy, N. Surface acoustic wave humidity sensor based on a thin PolyXIO film, *Sens. Actuators : B, Chem.*, 1998, **49**, 218–225. doi: 10.1016/S0925-4005(98)00131-2
- Santos, J.P.; Fernandez, M.J.; Fontech, J.L.; Lozano, J.; Alexandre, M.; Garcia, M.; Gutierrez, J. & Horrillo, M.C. SAW sensor array for wine discrimination. *Sens. Actuators : B, Chem.*, 2005, **107**, 291–295. doi: 10.1016/j.snb.2004.10.013
- Wen, Changbao; Zhu, Changchun; Ju, Yongfeng; Xu, Hongke & Qiu, Yanzhang. A novel NO₂ gas sensor using dual track SAW device. *Sens. Actuators: A*, 2010, **159**, 168-173. doi: 10.1016/j.sna.2010.03.012
- Joo, Byung-Su; Huh, Jeung-Soo & Lee, Duk-Dong. Fabrication of polymer SAW sensor array to classify chemical warfare agents. *Sens. Actuators : B, Chem.*, 2007, **121**, 47–53. doi: 10.1016/j.snb.2006.09.013
- Huang, Fu-Chun; Chen, Yung-Yu & Wu, Tsung-Tsong. A room temperature surface acoustic wave hydrogen sensor with Pt coated ZnO nanorods. *Nanotechnology*, 2009, **20**(6). doi: 10.1088/0957-4484/20/6/065501
- Dkjous, Corinne; Rebikre, Dominique; Pistre, Jacques; Tiret, Colette & Planade, Roger. A surface acoustic wave gas sensor: detection of organophosphorus compounds, *Sens. Actuators : B, Chem.*, 1995, **24-25**, 58-61. doi: 10.1016/0925-4005(95)85012-0
- Nakamoto, T.; Aoki, K.; Ogi, T.; Akao, S. & Nakaso, N. Odor sensing system using ball SAW devices. *Sens. Actuators: B, Chem.*, 2008, **130**, 386–390, doi.org/10.1016/j.snb.2007.09.022
- Bender, F.; Barie, N.; Romoudis, G.; Voigt, A. & Rapp, M. Development of a pre-concentration unit for a SAW sensor micro array and its use for indoor air quality monitoring. *Sens. Actuators : B, Chem.*, 2003, **7076**, 1–7. doi: 10.1016/S0925-4005(03)00239-9
- Wilson, Denise M.; Hoyt, Sean; Janata, Jiri; Booksh, Karl & Obando, Louis. Chemical sensors for portable, handheld field instruments. *IEEE Sensors J.*, 2001, **1**(4), doi: 10.1109/7361.983465
- Hao, H.C.; Tang, K.T.; Ku, P.H.; Chao, J.S.; Li, C.H.; Yang, C.M. & Yao, D.J. Development of a portable electronic nose based on chemical surface acoustic wave array with multiplexed oscillator and readout electronics, *Sens. Actuators : B, Chem.*, 2010, **146**, 545–553. doi: 10.1016/j.snb.2009.12.023.
- Kea-Tiong Tang; Shih-Wen, Chiu; Hsu-Chao, Hao; Shang-Chia, Wei; Tai-Hsuan, Lin; Chia-Min, Yang; Da-Jeng, Yao & Wei-Chang, Yeh. An electronic-nose sensor node based on polymer coated surface acoustic wave array for environmental monitoring. *IEEE ICGCS 2010*, pp. 118 - 122. doi: 10.1109/ICGCS.2010.5543083
- Wu, Cheng-Chun; Liu, Szu-Chieh; Chiu, Shih-Wen & Tang, Kea-Tiong. A Low Noise CMOS readout based on a polymer-coated SAW array for miniature electronic nose. *Sensors 2016*, **16**(11), 17. doi: 10.3390/s16111777.
- Nimal, A.T.; Mittal, Upendra; Singh, Mohan; Khaneja, Mamta; Kannan, G.K.; Kapoor, J.C.; Dubey, Vinita; Gutch, P.K.; Lal, Gobardhan; Vyas, K.D. & Gupta, D.C. Development of handheld SAW vapor sensors for explosives and CW agents. *Sens. Actuators B, Chem.*, 2009, **135**, 399–410. doi: 10.1016/j.snb.2008.08.040
- Fahim; Mainuddin; Mittal, U.; Kumar, Jitender; Nimal,

- A.T. & Sharma, M.U. Single chip readout electronics for SAW-based gas sensor systems. *IEEE SENSORS* 2017. doi: 10.1109/ICSENS.2017.8233886
21. Nimal, A.T.; Singh, Mohan; Mittal, U. & Yadava, R.D.S. A comparative analysis of one-port Colpitt and two-port Pierce SAW oscillators for DMMP vapor sensing. *Sens. Actuators : B, Chem.*, 2006, **114**, 316–325. doi: 10.1016/j.snb.2005.05.021
 22. Penza, M. & Cassano, G. Relative humidity sensing by PVA-coated dual resonator SAW oscillator, *Sens. Actuators : B, Chem.*, 2000, 68, 300–306. doi: 10.1016/S0925-4005(00)00448-2
 23. Wohltjen, H. & Dessy. Surface acoustic wave probe for chemical analysis. *Anal. Chem.*, 1979, **51**(9), 1458–1464. doi: 10.1021/ac00089a023.
 24. D'Amico, & Verona, E. Saw sensors. *Sens. Actuators*, 1989, 17, pp 55–66. doi: 10.1016/0250-6874(89)80064-2
 25. Eric Monmasson. FPGAs in industrial control applications. *IEEE Trans Ind. Informat.*, 2011, **7**(2). doi: 10.1109/TII.2011.2123908
 26. Encyclopedia of computer science and technology. edited by Phillip A. Laplante. doi: 10.1081/E-ECST
 27. Panigrahy, D.; Rakshit, M. & Sahu, P.K. FPGA implementation of heart rate monitoring system. *J Med Syst.*, 2016, **40**(49). doi: 10.1007/s10916-015-0410-4
 28. Siddiqui, Asim; Mahboob, Md. Rahat; Khan, Anwar U.; Khan, S.A.; Islam, Tarikul & Shahani, D.T. A highly sensitive readout circuitry for a wide range thin film capacitive humidity sensors. *IEEE ET2ECN*, 2014, pp. 1-5. doi: 10.1109/ET2ECN.2014.7044941.
 29. Piedra, Antonio de la.; Braeken, An. & Touhafi, Abdellah. Sensor systems based on FPGAs and their applications: A Survey. *Sensors*, 2012, **12**(9), 12235-12264. doi.org/10.3390/s120912235.
 30. Vig, John R. & Walls, Fred L. A review of sensor sensitivity and stability. *IEEE/EIA IFCSE*, pp. 30-33, 2000. doi: 10.1109/FREQ.2000.887325.
 31. Hsieh, Mu-Hsien; Cheng, Fan-Chieh; Shie, Mon-Chau & Ruan, Shanq-Jang. Fast and efficient median filter for removing 1–99% levels of salt-and- pepper noise in images. *Engineering Appl. Artificial Intel.*, 2013, **26**, 1333–1338. doi: 10.1016/j.engappai.2012.10.012
 32. Gupta, Vikas; Chaurasia, Vijayshri & Shandilya, Madhu. Random-valued impulse noise removal using adaptive dual threshold median filter. *J. Vis. Commun. Image R.* 26, pp. 296–304, 2015. doi: 10.1016/j.jvcir.2014.10.004
 33. Holt, Charles C. Forecasting seasonals and trends by exponentially weighted moving averages. *Int. J. Forecasting.* **20**(1), 5-10, 2004. doi: 10.1016/j.ijforecast.2003.09.015
 34. Azami, Hamed; Mohammadi, Karim & Bozorgtabar, Behzad. An improved signal segmentation using moving average and Savitzky-Golay Filter. *J. Signal Infor. Processing*, 2012, 3, 39-44. doi: 10.4236/jsip.2012.31006
 35. Fong, Sim S.; Rearden, Preshious; Kanchagar, Chitra; Sasseti, Christopher; Trevejo, Jose & Breerton, Richard G. Automated Peak detection and matching algorithm for gas chromatography–differential mobility spectrometry. *Anal. Chem.*, **83**(5), 1537–1546. doi: 10.1021/ac102110y.

ACKNOWLEDGMENTS

Authors are extremely thankful to Director SSPL Dr Seema Vinayak, for permitting and supporting this work. They are also thankful to Dr M.U. Sharma and Dr J.S. Rawat for their support and patronage. Authors are also thankful to Dept. of Electronics and Information Technology (DietY) for their support under Visvesvaraya Scheme.

CONTRIBUTORS

Mr Fahim Durani received MTech (Instrument Technology) from Indian Institute of Technology Delhi, in 2012 and currently pursuing PhD from Jamia Millia Islamia University, Delhi. He is working as Scientist 'E' in DRDO-Solid State Physics Laboratory, Delhi. His research interests include FPGA design, surface acoustic wave sensor-based chemical detectors, sensor interface electronics and Instrumentation.

In the current study, he has carried out design and development of FPGA based digital electronics. He has also developed VHDL coding, synthesised and validated the codes. He carried out the experimental work and has written/prepared the manuscript.

Prof. Mainuddin received ME from the Department of Electronics and Communication Engineering, Delhi College of Engineering, in 2003 and PhD from Jamia Millia Islamia, New Delhi, in 2008. Presently working as a Professor at the department of Electronics and Communication Engineering, Jamia Millia Islamia, New Delhi. He has over 100 research publication in journals/conferences. His research interests include optoelectronics, optical diagnostics, sensors and instrumentation and high power lasers.

In the current study, he has carried out design review, data analysis and result interpretation. He has continuously provided the guidance and given many valuable inputs.

Dr Upendra Mittal received his ME (Electrical Engineering) from Delhi College of Engineering, University of Delhi, in 2003 and PhD (electrical engineering) from Jamia Millia Islamia University, Delhi, in 2016. His current research interests are RF circuit design, RF characterisation and development of chemical vapour sensors and SAW Technology including fabrication of SAW devices and its application as sensors.

In the present study, he has carried out design, implementation and characterisation of SAW sensor electronic circuitry and supported in making experimental setup and carried out data collection and analysis.

Mr Jitender Kumar received his BSc (Life science) from University of Meerut, Meerut, in 2001 and MSc (Organic Chemistry) from University of Meerut, Meerut, in 2004. He is working as a Scientist at Solid State Physics Laboratory, Delhi. He is involved in the development and characterisation of Gas Chromatography and SAW based chemical sensor.

In the present study he has carried out design and implementation of vapour generator. He carried out the literature survey on VOCs and their detection techniques. He also contributed towards the safe handling of chemicals and concentration verification.

Mr Devendra Barlewar received his BE (EC) from Jamia Millia Islamia, Delhi, in 2003. He has been working as scientist in DRDO-Solid state Physics Laboratory. His areas of interest include Microcontroller based circuit design, RF circuit design and surface acoustic wave sensor based chemical detectors. In the current study, he has carried out the schematic design, design of PCBs, implementation of PC communication and interfacing of digital and sensor modules. He has also contributed towards noise analysis and reduction.

Dr A.T. Nimal received MSc (Physics) from Government Arts College, Bharathiar University, Coimbatore, (1993) in and PhD (2004) in Physics from National Physical Laboratory, Delhi, and University of Delhi, Delhi. He is working as a Scientist at DRDO-Solid State Physics Laboratory, Delhi. Presently involved in the development of SAW based electronic nose for CW agents. He was also involved in the design and development of SAW devices such as delay lines, dispersive delay lines, resonators and filters for the above sensors and signal processing.

In the current study, he has carried out the SAW sensor design, frequency counter design and software development in VB. He has helped in data analysis, result validation, review of incremental work.