

1987

What is a Subject? Non-Nominative Subjects in Icelandic

Elizabeth A. Cowper
University of Toronto

Follow this and additional works at: <https://scholarworks.umass.edu/nels>



Part of the [Linguistics Commons](#)

Recommended Citation

Cowper, Elizabeth A. (1987) "What is a Subject? Non-Nominative Subjects in Icelandic," *North East Linguistics Society*. Vol. 18 , Article 8.

Available at: <https://scholarworks.umass.edu/nels/vol18/iss1/8>

This Article is brought to you for free and open access by the Graduate Linguistics Students Association (GLSA) at ScholarWorks@UMass Amherst. It has been accepted for inclusion in North East Linguistics Society by an authorized editor of ScholarWorks@UMass Amherst. For more information, please contact scholarworks@library.umass.edu.

WHAT IS A SUBJECT? NON-NOMINATIVE 'SUBJECTS IN ICELANDIC'

Elizabeth A. Cowper

University of Toronto

The notion of subject is not primitive in the theory of government and binding. However, certain properties have been traditionally associated with subjects: nominative case, participation in inversion processes, superiority of various kinds. If the theory is correct in treating subjecthood as a derived notion, then the possibility arises that subject properties might not all be observed to hold of the same element in a sentence. In this paper, I will argue that Icelandic provides an example of this.

It has been claimed (Thrainsson 1979, Andrews 1982, Zaenen, Maling and Thrainsson 1985, Yip, Maling and Jackendoff 1986) that there are non-nominative subjects in Icelandic. Specifically, these authors claim that in sentences like those in (1), the clause-initial argument is not a topicalized constituent, but rather is the subject of the sentence, despite the fact that it is not nominative, and that the verb fails to agree with it.

ELIZABETH A. COWPER

- (1) a. **mig sækir syfja**
me(acc.) seeks(3sg) sleepiness(nom.)
 'I am sleepy'
- b. **mér byður við setningafræði**
me(dat.) is-nauseated(3sg) at syntax
 'I abhor syntax'

Zaenen, Maling and Thrainsson (1985) demonstrate that what they term 'oblique subjects' have properties which are characteristic of subjects but not of topics. Some of their examples are given in (2) - (7).

(2a) shows that an oblique subject may serve as the antecedent of a reflexive pronoun, while (2b) shows that a topicalized constituent cannot bind a reflexive pronoun.

- (2) a. **Henni_i þykir bróðir sinni/*hennar_i leiðinlegur**
her(D) thinks brother(N) her(*-REFL) boring
 'She finds self's/*her brother boring'
- b. **Siggu_i barði ég með dúkkuni hennar_i/*sinni_i**
Sigga(A) hit I(N) with her(*+REFL) doll
 'Sigga, I hit with her/*self's doll'

Oblique subjects participate in subject-verb inversion, whereas topicalized constituents do not, as shown in (3) and (4). In (3), the oblique subject henni inverts with the auxiliary verb to form a question, while in (4), the topicalized object Haraldi cannot participate in inversion. Thus (4b) is ungrammatical.

- (3) a. **Henni hefur alltaf þótt Olafur leiðinlegur**
she(D) has always thought Olaf(N) boring
- b. **Hefur henni alltaf þótt Olafur leiðinlegur?**
has her(D) always thought Olaf boring
 'Has she always thought Olaf boring'
- (4) a. **Haraldi hafði Sigga aldrei hjálpað**
Harald(D), Sigga(N) had never helped

NON-NOMINATIVE SUBJECTS IN ICELANDIC

- b. *Hafði Haraldí Sigga aldrei hjálpað?
had Harald(D), Sigga(N) never helped

Oblique subjects, but not topicalized constituents, occur clause-initially in an extraction domain, as shown in (5).

- (5) a. Hvenær_i telur Jón [að henni hafi þótt Ólafur leiðinlegur t_i]
when believes J.(N) that she(D) has thought O. boring?
'When does John believe that she thought Olaf boring?'
- b. *Hvenær_i telur Jón [að Harald hafi María kysst t_i]?
when believes J.(N) that H.(A) has M.(N) kissed
'When does John believe that Harald, Mary kissed?'

Oblique subjects but not topics undergo indefinite-subject postposing, as shown in (6).

- (6) a. Það hefur einhverjum þótt Ólafur leiðinlegur
there has someone(D) thought Olaf(N) boring
'Someone has found Olaf boring'
- b. *Það hefur hjóli þjófurinn stolið
There has a bicycle(A) the thief(N) stolen
'A bicycle, the thief has stolen'

Finally, oblique subjects may surface as controlled PRO. This is illustrated in (7).

- (7) a. Mig vantar peninga
me(A) lacks money(A)
'I need money'
- b. Eg vonast til að PRO vanta ekki peninga
I hope for to PRO lack not money
'I hope not to need money'

There is thus a systematic difference between oblique subjects and topicalized constituents in Icelandic. Oblique subjects are clearly more subject-like than topicalized constituents. However, it is insufficient simply to say that they are subjects. In the works mentioned above, it is stipulated that the verb does not agree with the subject. It agrees with the nominative case-marked argument if one is present, and is

ELIZABETH A. COWPER

marked third person singular otherwise.

It is my aim to come up with an analysis of these Icelandic facts in which neither the subjectlike properties of these oblique NP's nor the verb agreement facts need to be stipulated.

I begin by claiming that in Icelandic, all verbal arguments originate inside VP (see Fukui 1986). The D-structure of a sentence like (8) is thus as shown in (9).

- (8) Hann lamdi hana
 he(N) hit her(A)
 'He hit her'

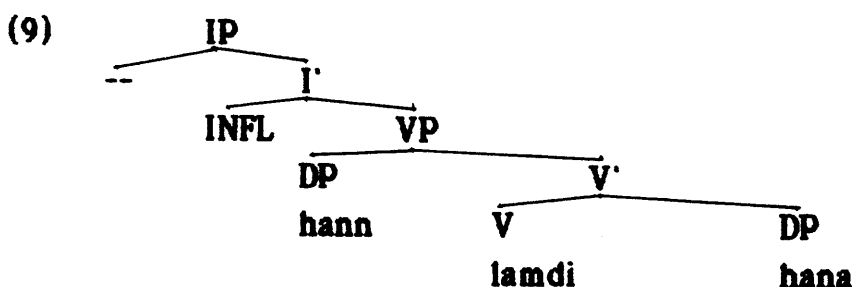

The specifier of IP is therefore not a θ -position.

The S-structure of (8), given in (10), results from the movement of the nominative DP to specifier position in IP, and the movement of the verb to INFL.

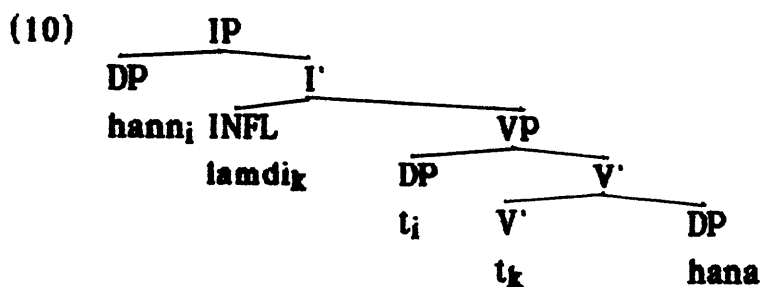

Secondly, I would like to propose that case is invariably assigned to the right. This claim will be refined below. For the moment, however, this means that INFL will assign nominative case, not to the specifier of IP as in English, but rather to VP. Since VP cannot bear case, the nominative case feature is realized on the argument in the VP specifier.¹ In (10), this means that hann 'he'

NON-NOMINATIVE SUBJECTS IN ICELANDIC

receives nominative case from INFL through its trace in the VP specifier. Thus the specifier of IP seems not to be a case position.

The S-structure of (1a) is given in (11). Mig, in the IP specifier, receives case from its trace in the verb phrase. Syfja, in the VP specifier, receives nominative case from INFL.

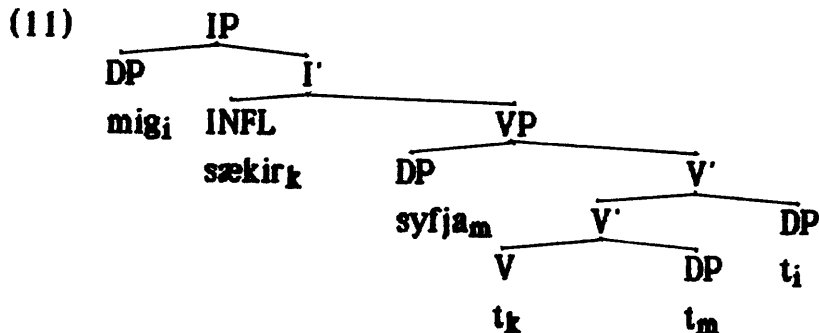

The structure of a topicalized sentence, on the other hand, involves CP. The S-structure of (2b), an example of topicalization, is given in (12).

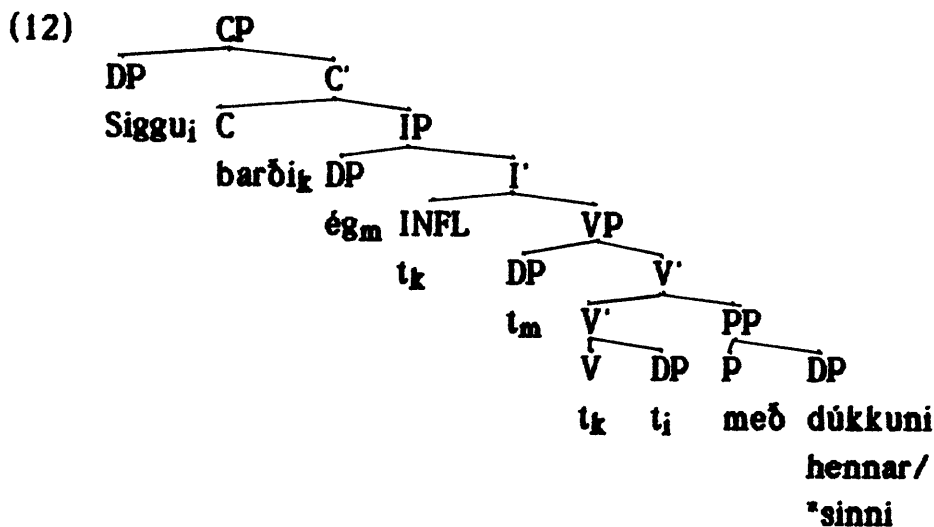

Before discussing any further details of this analysis, I will briefly show how the structures in (11) and (12) might account for the data in (1)-(7). The verb agreement in (1) is accounted for if we assume that AGR in INFL must share person and number features with the argument which INFL governs and casemarks. In (1a), this element is the DP syfja 'sleepiness', while in (1b) there is an empty expletive pronominal in the VP specifier position.

ELIZABETH A. COWPER

The binding facts in (2) are relatively straightforward. Consider the S-structure of (2a), given in (13).

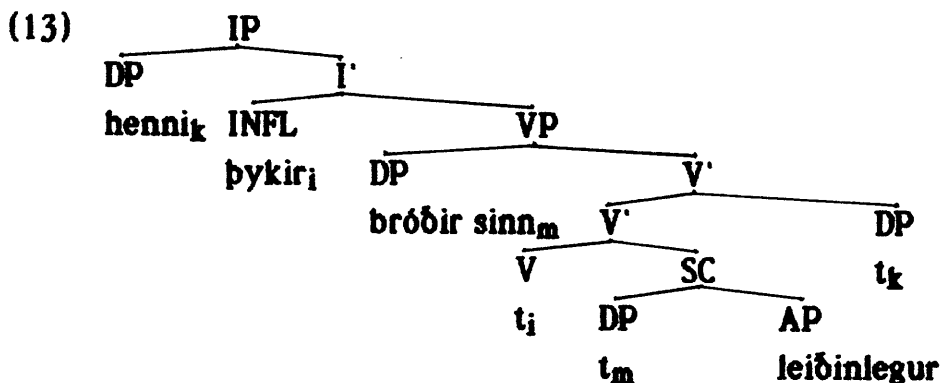

Henni in specifier position in IP, and also its trace in the verb phrase, are in a position to bind the reflexive. Both henni and the trace c-command the reflexive and are sufficiently local, being within IP. The situation in (2b), shown in (12), is rather different. The Θ -trace of the topicalized constituent does not c-command the reflexive and therefore cannot bind it. The topicalized constituent c-commands the reflexive, but occurs outside IP in an \bar{A} -position. As such, it cannot locally A-bind the reflexive.

Let us now turn to the inversion facts in (3). I assume that inversion involves the movement of a verb from INFL to COMP. In (3a,b), henni is in specifier position in IP, and hefur moves from INFL in (3a) to COMP in (3b). In (4a), on the other hand, Haraldi is in specifier position in CP while hafði is in COMP. There is thus no further possibility for movement of hafði to the left of Haraldi, and (4b) is ungrammatical.

Leaving aside for the moment the data in (5), let us look at indefinite-subject postposing. By my hypothesis, 'someone' in (6a) must occupy the IP specifier position. This means that the auxiliary verb has moved to COMP, and that the expletive það occupies the CP specifier position. The ungrammaticality of (6b) is thus accounted for, since hjóli, the topicalized constituent, occupies the CP specifier. Just as with the inversion cases, there is no way to move the auxiliary to the left of the topicalized constituent, and in addition there is no position for það to occupy.

Thus it seems that the structures I have proposed for oblique

NON-NOMINATIVE SUBJECTS IN ICELANDIC

subjects and for topicalized constituents provide a basis on which to distinguish their behaviour. However, there are many details still to be worked out.

First, if the IP specifier is neither a Θ -position nor a case position, why does a sentence like (2b) unambiguously involve topicalization? By the hypothesis I have just outlined, it ought to be possible for *ég* to remain in the VP specifier, leaving the IP specifier free to receive the accusative object. Second, why are oblique subjects in Icelandic as limited as they are? The fact is that oblique subjects occur with a restricted class of verbs, all of which assign quirky case, and are either ergative verbs or psych verbs.. The answer to these questions will involve a close look at the nature of case assignment in Icelandic, and in particular at how case is assigned in sentences involving oblique subjects.

I make the following assumptions about case assignment. First, a particular verb may be lexically associated with one or more morphological case features. When present, such features are linked to the verb's Θ -grid. Thus, for example, a verb like *þykir* has the representation given in (14).

(14) <experiencer, theme>
 |
 DATIVE

Second, a verb may have what I shall refer to as a structural case grid, consisting of one or more structural case positions. The verb *lamdi*, which lacks quirky case but assigns case to its object, has the representation in (15).

(15) <agent, theme>
 (—)

There is a system of default rules which fills in the appropriate morphological case features for a verb such as *lamdi*. My final assumption is that at S-structure, an argument must be associated with both a morphological case feature and a structural case position.

Given these assumptions, there are various possibilities for the

ELIZABETH A. COWPER

case-assigning properties of a verb. A verb might assign morphological case, but not structural case, or it could assign structural case alone, leaving the morphological case to be specified by default. A third possibility is that the verb assigns both structural and morphological case.

I will claim that verbs taking oblique subjects assign morphological case, but no structural case, to the argument which surfaces as the oblique subject. This argument cannot remain in its D-structure position, but must move so as to receive structural case. The case-assigning properties of INFL are as follows. INFL has two structural case positions associated with it. Following Cowper (1987), this means that structural case will be assigned both to the specifier and to the complement of INFL. However, the default rules spelling out morphological case are incomplete in the case of INFL. Nominative case is filled in only for the structural case associated with the complement of INFL, and is therefore realized on the argument in the VP specifier.

Let us now see how the analysis just outlined will account for sentences with oblique subjects. An example is given in (16).

- (16) **Mér brestur kjarkur**
 me(D) lacks(3sg) courage(N)
 'I lack courage'

- (17) D-structure:

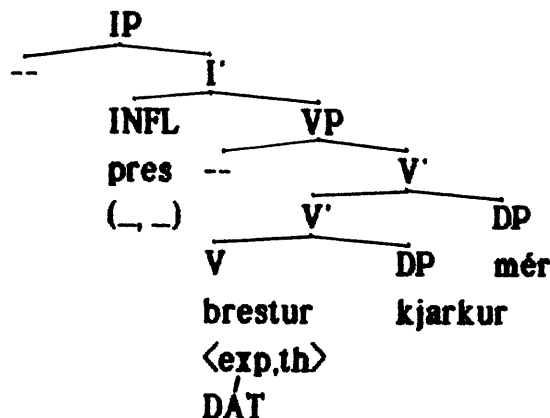

The verb brestur 'lack' is a psych verb, and following Belletti and Rizzi (1986), has no external argument. It has one morphological case feature associated with it, but no structural case. The dative feature is

NON-NOMINATIVE SUBJECTS IN ICELANDIC

linked to the experiencer. The only possible S-structure is given in (18).

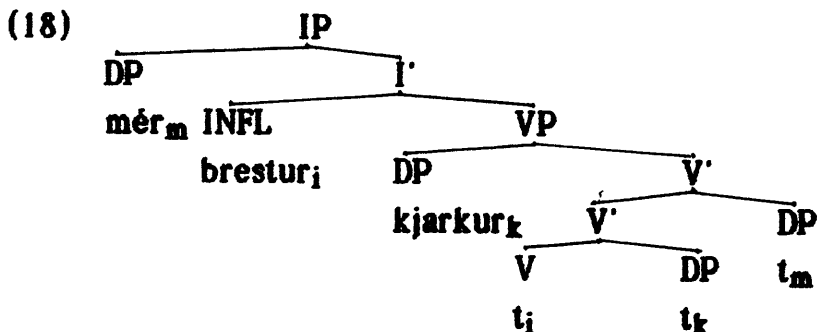

Kjarkur receives neither morphological nor structural case from the verb. As such, it must move to a position to which both structural case and default morphological case are assigned, namely the VP specifier position. Mér, on the other hand, receives (dative) morphological case, but no structural case, from the verb. It must therefore move to a position to which only structural case is assigned. If the positions of the arguments were reversed in (18), kjarkur would lack morphological case and mér would receive two morphological case features.

Let us now look at an example without an oblique subject.

(19) hann lamdi hana
 he(N) hit her(A)

(20) a. D-structure

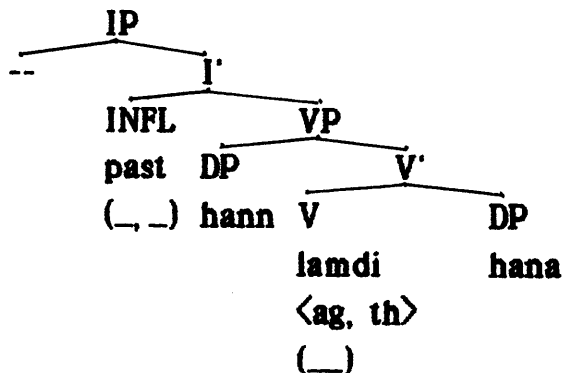

ELIZABETH A. COWPER

(21) S-structure:

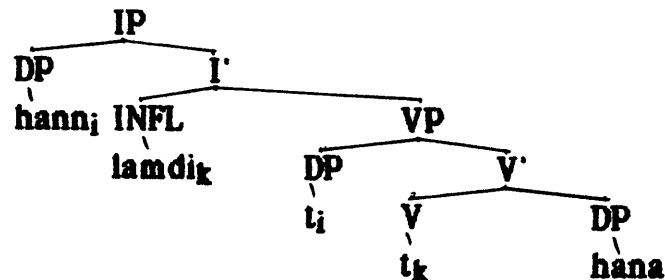

Here, the verb, or more properly its trace, assigns structural case to the direct object. The accusative case feature arises by default specification. INFL assigns structural case to the trace of hann in the VP specifier, and the nominative case feature arises by default. However, it would seem that hann should receive a second structural case from INFL in the IP specifier position. Why is this sentence grammatical?

In order to answer this question, let us think for a moment about what structural case is. A reasonable view is that structural case is simply a relationship, expressed by coindexing, between an argument and a case-assigner. Thus, if an argument receives structural case from a particular case-assigner, it is coindexed with that case-assigner. If the same argument receives structural case again from the same case-assigner, the representation will not change in any way. It thus does not matter that hann receives structural case twice from INFL.

Let us now return to sentence (2b), repeated here as (22).

- (22) *Siggu barði ég með dúkkuni hennar*
 Sigga(A) hit I(N) with doll her
 'Sigga, I hit with her doll'

The question was why (22) can only be interpreted as an instance of topicalization. (23) shows the S-structure that would arise if Siggu were treated as an oblique subject.

NON-NOMINATIVE SUBJECTS IN ICELANDIC

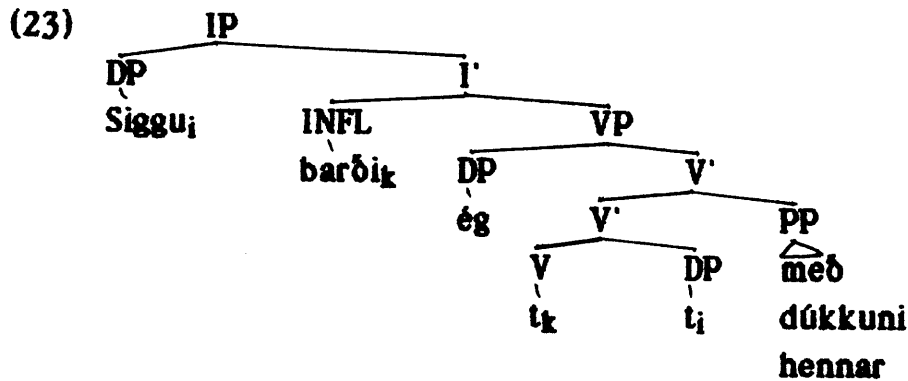

In this example, the trace of Siggu receives structural case from the trace of the verb. The accusative case feature arises by default. However, Siggu also receives structural case from INFL. This example is very different from the preceding one. There, the nominative argument received structural case twice from the same case-assigner. Here, Siggu is receiving structural case once each from two distinct case-assigners, giving an ill-formed representation.

I have outlined a system of case assignment which allows the theory to distinguish oblique subjects from topicalized constituents in a principled way, and which accounts for the fact that the only oblique elements which behave like subjects are those which receive lexically specified morphological case from the verbs of which they are arguments.

Several questions remain. First, why is it that only ergative and psych verbs have oblique subjects? There are other verbs whose objects receive lexically specified morphological case. An example is given in (24).

- (24) a. Guðrun saknar Haraldar
 Guðrun(N) misses Harald(G)
 'Guðrun misses Harald'
- b. Haraldar saknar Guðrun
 Harald(G) misses Guðrun(N)
 'Harald, Guðrun misses'

According to Zaenen, Maling and Thrainsson (1985), (24b) is unambiguously an instance of topicalization. It seems that this verb must be analyzed as assigning structural, as well as morphological case, to

ELIZABETH A. COWPER

its object, giving it the representation in (25).

- (25) <exp, th>
 |
 GEN
 (—)

The movement of Haraldar to the IP specifier would give Haraldar two structural cases, one from the verb and the other from INFL. (24) thus represents essentially the same situation as (22).

Another question which must be answered is why oblique subjects can surface as controlled PRO. Controlled PRO occurs in infinitival clauses, where INFL, we assume, has no structural case to assign. The embedded clause in (7b), repeated here as (26), has the structure in (27).

- (26) ... til að PRO vanta ekki peninga
 ... to that PRO lack not money
 '... not to lack money'

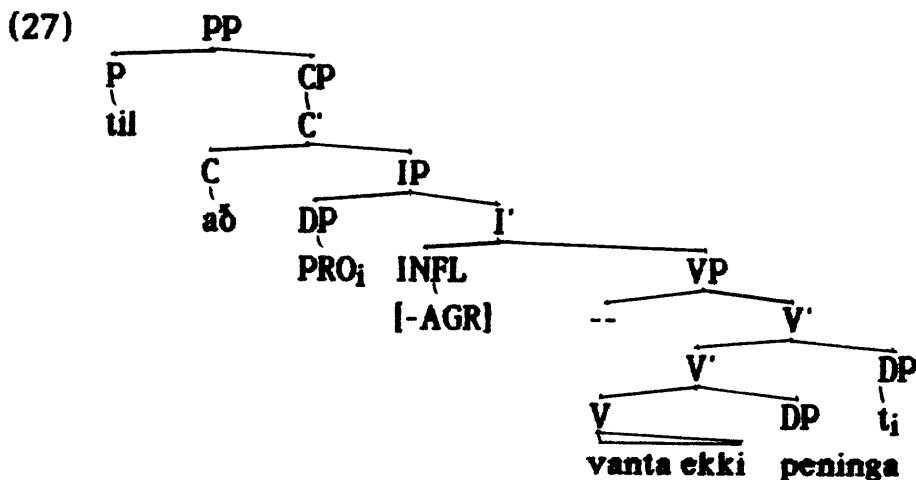

The verb vanta assigns lexical accusative case, but no structural case to the trace of PRO. Whether or not PRO moves through the VP specifier, it will not receive structural case from INFL, since INFL has no structural case to assign. Given that a lexical argument must have both structural and morphological case, and assuming that any argument lacking either or both of these can be non-lexical, we have accounted for the presence of PRO in this example.

NON-NOMINATIVE SUBJECTS IN ICELANDIC

Finally, let us return to the extraction data in (5), repeated here with some additions as (28-29).

- (28) a. **Jón telur [CP að [IP henni hafi þótt Olafur leiðinlegur]]**
 John(N) believes that she(D) has thought Olaf boring
- b. **Hvenær_i telur Jón[t_j[að henni hafi þótt Olafur leiðinlegur t_j]**
 when believes Jon(N) that she(D) has thought Olaf boring?
 'When does John believe that she thought Olaf boring?'
- (29) a. **Jón telur [að [Harald_k hafi María kysst t_k]]**
 John(N) believes that Harald(A), Mary(N) kissed.
- b. ***Hvenær_i telur Jón [að Harald hafi María kysst t_j]?**
 when believes J.(N) that H.(A) has M.(N) kissed
 'When does John believe that Harald, Mary kissed?'

The analysis of (28a), which contains an oblique subject, is straightforward. The \bar{A} -chain headed by *hvenær* is well-formed, with antecedent government holding between all chain links. The problem arises with (29). I have stated that topicalization in Icelandic involves the movement of the verb to COMP, and the movement of the topicalized constituent to the CP specifier position. The difficulty in (29a) is that the topicalized structure is clearly embedded inside another CP headed by *að*. This problem is by no means confined to Icelandic; English sentences like (30) are grammatical for many people.

- (30) John said that Mary, he would never hire.

A possibility one might consider for English, but not, as we shall see, for Icelandic, is that the topicalized constituent is adjoined to IP in some way. However, assuming the properties of adjunction structures given in Chomsky (1986), IP-adjunction does not create an additional barrier. It therefore predicts that it should be as possible to extract from a topicalized structure as from a non-topicalized structure. This prediction is false, as shown in (31).

- (31) a. *When do you think that John, we should hire?
 b. When do you think that we should hire John?

IP-adjunction is not even a possibility for Icelandic, since topical-

ELIZABETH A. COWPER

ization also triggers inversion of the finite verb with the subject. We are thus stuck with a CP analysis for Icelandic. However, a CP treatment of topicalization does neatly account for the extraction facts, since the presence of a second CP with a filled specifier position will constitute an impenetrable barrier for antecedent government.

To summarize, I have argued that oblique subjects in Icelandic are, indeed, subjects in a sense. The assumption that INFL in Icelandic assigns nominative case to its complement, and purely structural case to its specifier, provides a non-stipulative account of exactly which subject properties are exhibited by oblique subjects. The conclusion to be drawn from this is that the notion of subject is not necessarily a unified one. The usual characteristics of subjects follow either from their structurally prominent S-structure position, or from the fact that they are governed and case-marked by INFL. When these two criteria pick out different arguments, as they often do in Icelandic, then there are two apparent 'subjects', neither of which has all the properties traditionally associated with subjecthood.

* I am indebted to Diane Massam for helpful discussion, and to Joan Maling for comments at the conference. All remaining errors are of course my own.

† I am assuming a theory of barriers in which no maximal projection is a barrier for its own specifier.

REFERENCES:

- Andrews, Avery. 1982. 'The Representation of Case in Modern Icelandic' in J. Bresnan (ed.) The Mental Representation of Grammatical Relations, MIT Press, Cambridge, pp. 427-503.
- Belletti, Adriana and Luigi Rizzi. 1986. 'Psych-Verbs and θ -Theory', ms.
- Chomsky, Noam. 1986. Barriers, MIT Press, Cambridge.
- Cowper, Elizabeth A. 1987. 'Case Assignment and Syntactic Grids', ms.

NON-NOMINATIVE SUBJECTS IN ICELANDIC

**Thráinsson, Hoskuldur. 1979. On Complementation in Icelandic.
Garland, New York**

**Yip, Moira, Joan Maling and Ray Jackendoff. 1987. 'Case in Tiers'
Language, vol 63, no. 2, pp. 217-250**

**Zaenen, Annie, Joan Maling and Hoskuldur Thráinsson. 1985. 'Case and
Grammatical Functions: The Icelandic Passive' Natural
Language and Linguistic Theory, vol 3, no. 4, pp. 441-484.**