

Photochemical Degradation of Organic Pollutants in Wastewaters

Gaukhar Balbayeva, Azat Yerkinova, Vassilis J Inglezakis and Stavros G Pouloupoulos*

Department of Chemical Engineering, Environmental Science & Technology Group (ESTg), School of Engineering, Nazarbayev University, Astana, Kazakhstan.

*Email: stavros.pouloupoulos@nu.edu.kz

Abstract. In the present work, the photochemical treatment of a synthetic wastewater in a batch recycle photochemical reactor using ultraviolet irradiation (254 nm, 6 W), hydrogen peroxide and ferric ions was studied. Reactor volume was 250 mL with 55.8 mL of irradiated volume in the annular photoreactor. The synthetic wastewater was composed mainly of organic carbon. The effect of initial total carbon (136-1080 mg L⁻¹), initial H₂O₂ amount (1332-5328 mg L⁻¹), pH, and Fe(III) presence (2-40 ppm), on total carbon (TC) removal was studied. Each experiment lasted 120 min, and the process was attended via pH and TC concentration. Direct photolysis in the absence of any oxidant had practically no effect on TC removal. Regarding the effect of initial TC concentration in the wastewater keeping the same initial hydrogen peroxide concentration (2664 mg L⁻¹), it was observed that for 136-271 mg L⁻¹ TC, around 60% TC removal was achieved, while when initial TC was increased at 528 mg L⁻¹, the TC removal observed decreased to 50%. For a further increase in TC at 1080 mg L⁻¹, TC removal dropped to 14%. Initial pH adjustment of the wastewater resulted in slight variations of the TC removals achieved. Finally, adding Fe(III) in the process was beneficial in terms of TC removal obtained. Particularly, the addition of 40 ppm Fe(III) in the presence of 2664 mg L⁻¹ H₂O₂ and initial TC equal to 528 mg L⁻¹ increased the TC removal from 50% to 72%.

1. Introduction

Nowadays the efficient use of natural resources becomes more and more important, as world population is steadily increasing, and standard of living is being improved. Access to clean, drinking water is of paramount importance for sustaining life, preserving health, and ensuring development. It should be noted that the problem of water is associated with two dimensions; it is related with both insufficient resources to fulfil people's needs and with water pollution caused by human activities. Specifically, discharging of untreated wastewater into water bodies is a problem associated with water pollution and water management. Wastewater treatment technologies (WWT) can help to prevent water pollution, and depending on the degree of treatment, it can decrease also the water demand for industrial or agricultural purposes by recycling the treated water back to the process. WWT are used to remove chemicals, bacteria, and other contaminants from wastewaters before they are recycled back into the process or discharged to the environment. Consequently, there is an expanding worldwide interest in such techniques, and research on more advanced technologies for purifying water is of continuously great importance.

Advanced Oxidation Processes (AOPs) are classified as very useful methods used for the degradation of toxic organic compounds [1]. Processes are classified as "AOPs", when hydroxyl radicals ($\bullet\text{OH}$) are formed and used for the oxidation of organic pollutants [2]. Hydrogen peroxide (H₂O₂) can play the role of hydroxyl radicals source after being irradiated with ultraviolet (UV) light.



In that case, the process is further classified as photochemical treatment. There is a number of studies conducted on different types of AOP technologies applied for the degradation of toxic compounds [1-18]. Most of these studies refer to the treatment of single compounds in water. More studies need to be performed using complex wastewaters, while photochemical treatment can be effective in cases where traditional WWT fail to eliminate the target compounds like emerging pollutants.

This paper focuses on the photochemical treatment of a synthetic organic wastewater using UV light and H₂O₂. The efficiency of the photo-Fenton like process (UV/H₂O₂/Fe(III)) is also examined [3].

2. Experimental Details

2.1. Chemicals and Reagents

Photochemical treatment was applied for a synthetic wastewater. The composition of the synthetic wastewater is provided in table 1. All compounds used, except lab lemco, were purchased from FISHER-CHEMICAL. Lab lemco was purchased from OXOID LTD.

Table 1. Composition of synthetic wastewater.

Compound	Assay	Concentration [mg L ⁻¹]	Molar weight [g/mol]	Total carbon [mg L ⁻¹]
D-Glucose anhydrous (C ₆ H ₁₂ O ₆)	≥97.5%	1600	180	639.4
Bacterial peptone		480		
Lab Lemco		320		
Ammonia hydrogen carbonate (CH ₅ NO ₃)	≥99%	160	79	24.3
Potassium hydrogen carbonate (CHKO ₃)	≥99%	80	100	9.6
Sodium hydrogen carbonate (CHNaO ₃)	≥99.7%	80	84	11.4

For pH adjustment, hydrochloric acid (HCl, 37% w/w) and sodium hydroxide (NaOH, ≥97.0% w/w) purchased from FISHER-CHEMICAL were used. Anhydrous FeCl₃ (≥97.0% w/w) from FISHER-CHEMICAL was used as source of Fe(III). Hydrogen peroxide (37.6% w/w) from SKAT-REACTIV was used as source of hydroxyl radicals.

2.2. Reactor Configuration and Experimental Procedure

All experiments were conducted with the apparatus illustrated in figure 1. A reactor with 250 mL solution was operated in batch recycle mode, where wastewater was continuously pumped through the annular photoreactor with an active volume of 55.8 mL. Ultraviolet light of 254 nm was produced from the 6 W lamp placed inside the photoreactor. A peristaltic pump with a rate of 175 mL min⁻¹ was used to continuously circulate the wastewater solution. A magnetic stirrer was used to constantly mix the part of the solution that was not directly irradiated by UV-lamp. Throughout the whole duration of each experiment the pH was measured. The pH electrode LE409 by Mettler Toledo was used.

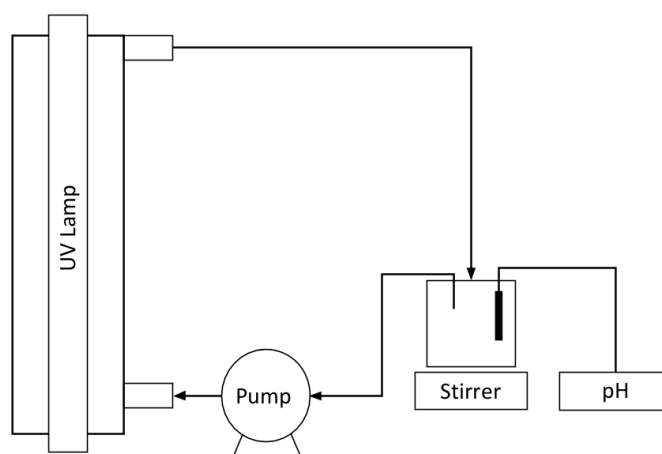

Figure 1. The experimental setup.

All experiments lasted two hours. The start of the experiment was considered immediately as the UV-lamp with the pump was turned on. Samples were taken each 15 or 30 min and sent for total carbon (TC) analysis. TC analysis was performed using the Multi N/C 3100 instrument by Analytik Jena AG.

3. Results and Discussion

3.1. Direct Photolysis Using UV Light

Firstly, the direct effect of UV light on the treatment of the wastewater was examined. The initial concentration of total carbon was around 130 mg L^{-1} (95% organic carbon). After two hours of treatment with direct photolysis, the results obtained showed 0% conversion for TC removal, which meant that oxidant addition was required to achieve removal of total carbon from the solution.

3.2. Photochemical Treatment Using H_2O_2 with UV Light

Secondly, the degradation of total carbon in the synthetic wastewater under UV light in the presence of H_2O_2 was studied. Hydrogen peroxide under UV light irradiation decomposes to highly reactive $\bullet\text{OH}$ radicals, which then react with organic compounds leading to the degradation of total carbon in solution.

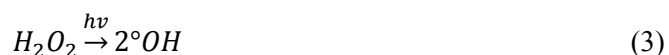

During the first step of these reactions, hydrogen peroxide breaks down into two ions (HO_2^- anion and H^+ cation). HO_2^- anion under the direct UV light leads to the desired formation of hydroxyl radicals ($\bullet\text{OH}$) [3]. The process behind this experiment can also be expressed in terms of overall reaction (3), which shows that two hydroxyl radicals are formed from using one molecule of hydrogen peroxide. Previous studies have showed that higher formation rates of hydroxyl radicals result in more effective decomposition of total carbon [2]. However, it has its own limitation as an excessive amount causes generation of hydroperoxyl radicals, which decrease the effectiveness of the degradation process [2].

The initial concentration of compounds plays a significant role in the effectiveness of the degradation process. Therefore, the initial concentration of TC was first varied, keeping constant the initial concentration of hydrogen peroxide (2664 mg L^{-1} or 78 mmol L^{-1}). It was observed that with initial concentration of 136 and 271 mg L^{-1} TC, around 60% TC removal was achieved (figure 2). When initial TC was further increased at 528 mg L^{-1} , the TC removal observed decreased to 50%. A

further increase in TC at 1080 mg L⁻¹, TC removal achieved dropped to around 14%. As a result of these observations, 528 mg L⁻¹ was used as initial TC concentration for next experiments.

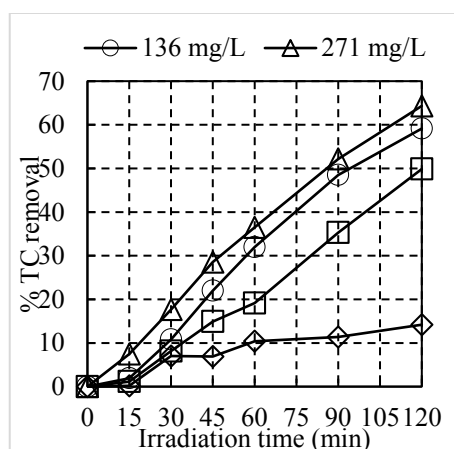

Figure 2. Effect of initial $[TC]_0$ in terms of conversion with constant H_2O_2 (2664 mg L⁻¹).

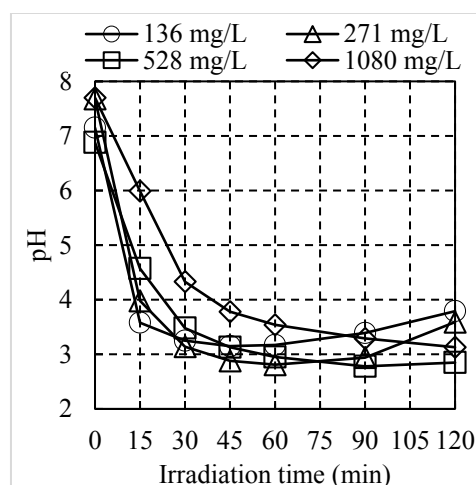

Figure 3. Effect of initial $[TC]_0$ in terms of pH with constant H_2O_2 (2664 mg L⁻¹).

The evolution of pH during these experiments is illustrated in figure 3. It can be noted that all experiments start approximately at pH 7. Then, pH values start to drop with time, implying that organic compounds degrade to organic acids, which in turn are decomposed slowly to carbon dioxide. At the last step, pH is expected to increase, as CO₂ leaves the solution.

The next step was to evaluate the optimum amount of H₂O₂ keeping constant the initial total carbon concentration. Specifically, the experiments were conducted for 1332, 2664 and 5328 mg L⁻¹ of hydrogen peroxide, and the mean initial TC value was 528 mg L⁻¹. The results obtained are shown in figure 4. Taking into account the TC removals achieved and the amount of H₂O₂ used, 2664 mg L⁻¹ of hydrogen peroxide were used for next experiments.

To examine whether the reaction follows a different pathway depending on the initial TC and H₂O₂ concentrations, a series of experiments was conducted for varied amounts of initial TC and H₂O₂ concentrations, but keeping the same initial TC/H₂O₂ (=4.9) ratio (figure 5).

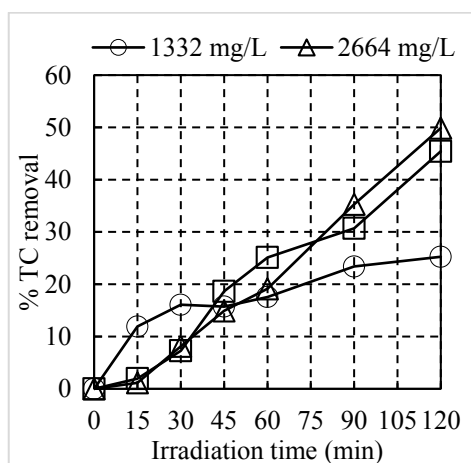

Figure 4. Effect of H_2O_2 in terms of conversion for constant initial TC (528 mg L⁻¹).

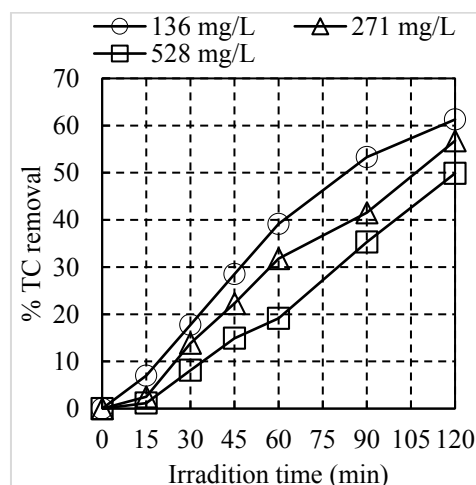

Figure 5. Effect of $[TC]_0$ in terms of conversion for constant $[TC]_0/[H_2O_2]_0$ ratio (=4.9).

3.3. Adjustment of pH

The effect of initial pH value of the synthetic solution on the photochemical degradation of organic pollutants ($[TC]_0=528 \text{ mg L}^{-1}$) using only H_2O_2 ($[H_2O_2]_0=2664 \text{ mg L}^{-1}$) was investigated. The results obtained are depicted in figures 6 and 7. Without any pH adjustment the initial pH of the solution was around 7. After two hours of operation 50% TC removal was achieved.

When the initial pH was lowered by addition of HCl to around 5, TC removal was slightly decreased to 45%. Finally, pH was increased to 8 by NaOH addition. Nevertheless, after hydrogen peroxide addition and process start, pH almost instantly dropped back to values around 5. In that case, the TC removal observed was 54%. The same trend was observed by other authors and the photochemical oxidation by hydrogen peroxide has been shown to be a pH-dependent process [19]. It was claimed that with higher pH, at alkaline conditions, the rate of photolysis using H_2O_2 is higher. This observation may be explained due to the higher molar absorption coefficient ($240 \text{ M}^{-1} \text{ cm}^{-1}$ at 254 nm) of the peroxide anion HO_2^- [19].

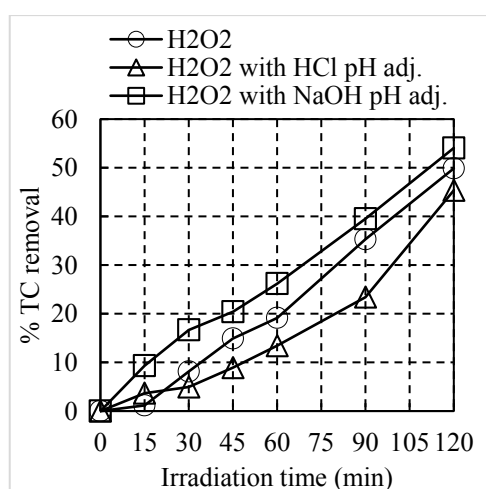

Figure 6. Effect of pH adjustment on process with H_2O_2 in terms of TC removal.

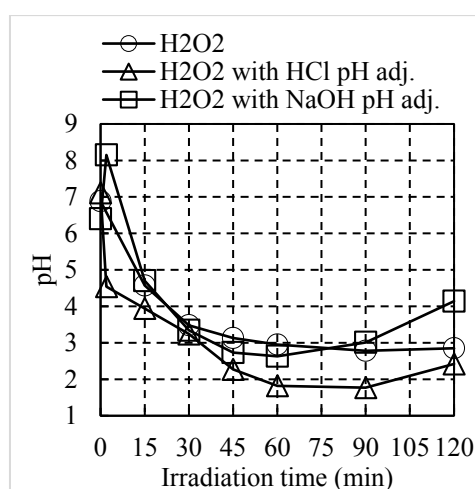
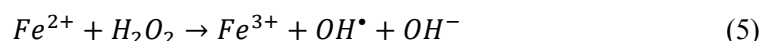
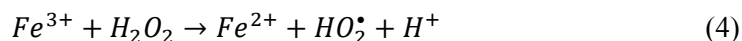

Figure 7. Effect of pH adjustment on process with H_2O_2 in terms of pH.

3.4. Photo-Fenton Process with Synthetic Wastewater

This method is based on accelerating H_2O_2 decomposition under UV irradiation by $Fe(III)$ addition (photo-Fenton “like” process). Reduction of Fe^{3+} to Fe^{2+} ensures the formation of $\bullet OH$ radicals as shown in reactions (4) and (5) [20].



The focus of these experiments was given on the effect of ferric ions concentration on the process. All experiments were conducted using the same initial TC (528 mg L^{-1}) and H_2O_2 (2664 mg L^{-1}) concentrations and different initial $Fe(III)$ amounts (0-40 ppm). It was observed that increasing initial $Fe(III)$ concentration resulted in higher TC removals after two hours. For the base case with no addition of $Fe(III)$, a conversion of 50% was achieved. The highest rate of TC removal of 72% was observed at 40 ppm of ferric ions (figure 8).

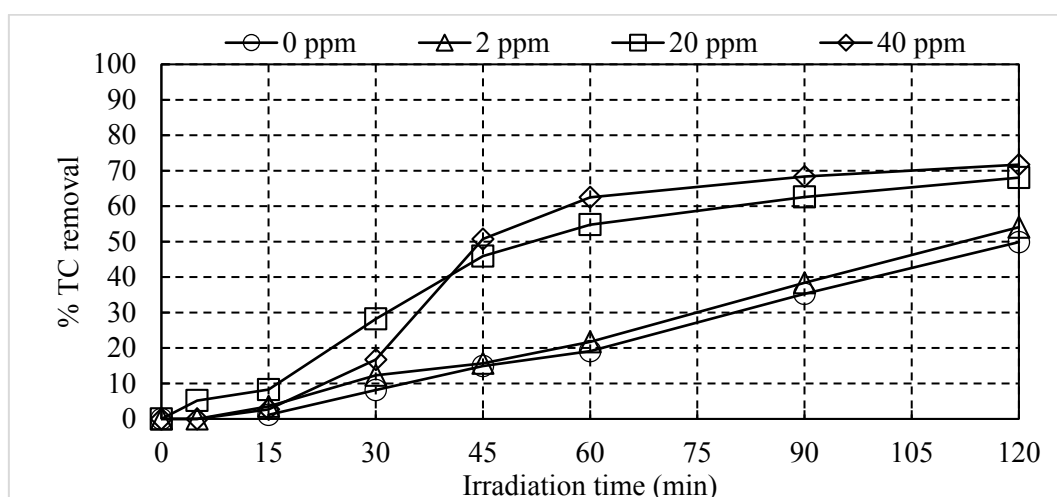

Figure 8. Effect of Fe(III) in terms of TC removal for initial TC 528 mg L⁻¹ and initial H₂O₂ 2664 mg L⁻¹

Increased concentrations of iron ions can significantly increase the generation of hydroxyl radicals, which in turn can lead to rapid removal of contaminants in the solution. However, a further increase in Fe ions will only result in a marginal improvement in the degradation of pollutants. This can be attributed to both increased turbidity of the solution due to excess iron that prevents the penetration of UV light and the reaction of hydroxyl radicals with excessive iron ions [21]. This trend is also depicted in figure 8 when Fe(III) was increased from 20 to 40 ppm.

4. Conclusion

Advanced Oxidation Processes and particularly photochemical processes can be effective in cases where traditional methods do not achieve the complete elimination of all harmful compounds in water like emerging pollutants. Moreover, more studies are required for treating complex wastewaters. In this work, the photochemical process (UV/H₂O₂/Fe(III)) was applied for the treatment of a synthetic wastewater containing mainly organic carbon. The main conclusions are:

(a) The photochemical treatment using UV (254 nm, 6W) and 2664 mg L⁻¹ H₂O₂ was effective in the mineralization of a synthetic complex wastewater with initial TC concentration 528 mg L⁻¹, leading to 50% TC removal after 2 h.

(b) The process can be significantly enhanced by the addition of ferric ions. Specifically, adding 40 ppm Fe(III) increased the TC removal achieved from 50% to 72%.

(c) Adjustment of initial pH from 7 to the value of 8 resulted in a slightly better TC removal; from 50% to 54%.

5. References

- [1] Pouloupoulos S G, Arvanitakis F and Philippopoulos C J 2005 *Journal of Hazardous Materials* B129 64-68
- [2] Stasinakis A 2008 *Global Nest Journal* 10 376-385
- [3] Munter R 2001 *Proceedings of the Estonian Academy of Sciences. Chemistry* 50 59-80
- [4] Chong M N, Jin B, Chow W K and Saint C 2010 *Water Research* 44 2997-3027
- [5] Zhao J 2012 *Procedia Environmental Sciences* 12 445-452
- [6] Carey J 1992 *Water Pollution Research Journal of Canada* 27 1-21
- [7] Chatzisyneon E, Stypas E, Boosios S, Xekoukoulotakis N P and Mantzavinos D 2008 *Journal of Hazardous Materials* 154 1090-1097
- [8] Coelho A, Castro A, Dezotti M and Sant'Anna G 2006 *Journal of Hazardous Materials* 137 178-184
- [9] Dincer A, Karakaya N, Gunes E and Gunes Y 2008 *Global NEST Journal* 10 31-38

- [10] Duguet J, Brodard E, Dussert B and Mallevalle J 1985 *Ozone: Science & Engineering* 7 241-258
- [11] El-Hajjoui H, Barje F, Pinelli E, Baily J, Richard C, Winterton P, Revel J and Hafidi M 2008 *Bioresource Technology* 99 7264-7269
- [12] Fenton H 1984 *Journal of the Chemical Society* 65 889-899
- [13] Latifoglu A and Gürol M D 2000 *Advanced Oxidation Processes in Water Treatment*. In: Hahn H.H., Hoffmann E., Ødegaard H. (eds) *Chemical Water and Wastewater Treatment VI*. Springer, Berlin, Heidelberg
- [14] Pignatello J, Oliveros E and MacKay A 2006 *Critical Reviews in Environmental Science and Technology* 36 1-84
- [15] Preis S, Terentyeva Y and Rozkov A 1997 *Water Science and Technology* 35 165-174
- [16] Sun J, Sun S, Fan M, Guo H, Lee Y and Sun R 2008 *Journal of Hazardous Materials* 153 187-193
- [17] Ugurlu M and Kula I 2007 *Environmental Science and Pollution Research* 14 319-325
- [18] Way T and Wan C 1991 *Industrial & Engineering Chemistry Research* 30 1293-1300
- [19] Andreozzi R, Caprio V, Insola A and Marotta R 1999 *Catalysis Today* 53 51-59
- [20] Deng Y and Englehard J 2006 *Water Research* 40 3683-3694
- [21] Mirzaei A, Chen Z, Haghghat F and Yerushalmi 2017 *Chemosphere* 174 665-688.