

## IOP Conference Series: Materials Science and Engineering

---

PAPER • OPEN ACCESS

# R1234yf vs R134a in automotive air conditioning system: A comparison of the performance

To cite this article: M Z Sharif *et al* 2020 *IOP Conf. Ser.: Mater. Sci. Eng.* **863** 012049

View the [article online](#) for updates and enhancements.

# R1234yf vs R134a in automotive air conditioning system: A comparison of the performance

M Z Sharif<sup>1,\*</sup>, W H Azmi<sup>1,2</sup>, N N M Zawawi<sup>1</sup>, R Mamat<sup>1</sup> and A H Hamisa<sup>1,3</sup>

<sup>1</sup> Department of Mechanical Engineering, College of Engineering, Universiti Malaysia Pahang, Lebuhraya Tun Razak, 26300 Gambang, Kuantan, Pahang, Malaysia.

<sup>2</sup> Automotive Engineering Centre, Universiti Malaysia Pahang, Pekan, Pahang 26600, Malaysia.

<sup>3</sup> Faculty of Engineering, University College of Yayasan Pahang (UCYP), Taman Gelora, Jln Dato' Abdullah, Kuantan Pahang, 25050, Malaysia.

\*E-mail: sharif5865@yahoo.com

**Abstract.** The main objective of this study is to evaluate the performance of a compact automotive air conditioning (AAC) system operating with R1234yf and R134a refrigerant. The different ranges of initial refrigerant charge and compressor speed have been tested on the AAC to evaluate the effect of different refrigerant on the thermodynamic performance. The results of this study have shown that the cooling capacity of R1234yf AAC system is significantly lower (between 5 to 25 %) than R134a system. In the experiment, the power of the compressor is slightly lower (up to 11 %) for refrigerant R1234yf compared to R134a inside the AAC system. Finally, the experimental results reveal that, under the same operating conditions, the COP of R1234yf AAC system is always lower than with R134a (14.5 % on average). In order to maximize the efficiency and performance of AAC system, further optimization needs to be done in order to reduce the gap in term of performance of the AAC system operating with R1234yf refrigerant.

## 1. Introduction

In the past, numerous types of refrigerant are being used inside vapor compression system. However, in recent years, researcher has understood that not all refrigerant is created equal. Some of the refrigerant blends is not safe and durable, while some of them contributes to ozone depletion and also global warming [1]. In 1992, the Kyoto protocol which is an international treaty has been held to discuss measures taken to reduce global warming by limiting greenhouse emission. At that time, R134a, R22, and R12 which is widely used in automotive should be phased out as the result of the treaty due to high global warming potential (GWP) [2]. The researcher has done various research to replace these high GWP and ozone depletion potential (ODP) refrigerant [1]. The promising replacement for the phased-out refrigerant is R-1234yf, R-290 (propane), R-600a (isobutane), R-1270 (propylene), R-774 (CO<sub>2</sub>), and R-717 (ammonia). All these refrigerants have zero ODP and low GWP.

As such, the R1234yf refrigerant identified as the best alternative to replace the current R134a refrigerant. At present, most of the European car is equipped with R1234yf refrigerant in their automotive air conditioning (AAC) system and is used without restriction. Moreover, the R1234yf refrigerant has thermodynamic properties almost similar to R134a refrigerant. Thus it can straightforwardly be used in the current AAC system without much modification to the original system.



The performance of the vapor compression system employing R1234yf refrigerant has been a debatable subject among researchers in these past several years. From the conducted literature survey, it has been found that several experimental studies have been performed to investigate the potential of direct substitution of R134a refrigerant with the R1234yf refrigerant system with minimum modifications to the existing system.

Several investigation findings showed that R1234yf refrigerant has significant environmental benefit compared to R134a refrigerant in AAC [3]. However, Park, Lee, Choe and Jung [4] reported a reduction of COP up to 2.7 % and the cooling capacity up to 4.0 % in the R1234yf refrigerant system compared to R134a. Hence, to overcome the performance reduction concern, the author proposed a mix ratio of R1234yf/R134a refrigerant. This newly proposed mixture has resulted in the reduction of the compressor discharge temperature up to 6.7 °C while the amount of refrigerant charge is decreased up to 11 %. Chen, Zhao and Qi [5] performed extensive experimental studies of R1234yf refrigerant MAC system at the different condition of driving mode. The studies show even under the various driving mode conditions, the system with R1234yf refrigerant proved to give out a lower performance of COP and cooling capacity compared to R134a system. Hence, further optimization and new energy-saving technologies are required to overcome this concern as suggested by the author. Later, Lee and Jung [6] conducted an experimental analysis to compare the performance of R1234yf and R134a in a MAC bench tester system integrated with the heat pump. The performance of these systems in summer and winter conditions using R134a and R1234yf refrigerant was done on an open type compressor for MACs bench tester. Interestingly, even though the experiment shows the reduction in cooling capacity and COP of the system with R1234yf compared to R134a refrigerant, the amount of refrigerant charge is 10 % lower in the R1234yf. This is because R1234yf has a lower density, so the use of the refrigerant can be saved [7]. Also, the compressor discharge temperature is 6.5 °C lower than those of the R134a system.

To date, experimental data for AAC systems using R1234yf are still limited. This paper is intended to update the knowledge regarding the behaviour of R1234yf inside the AAC system for the compact car. The experimental test setup used in this investigation used the real component from vehicles. In this paper, performance analysis of an AAC system using R134a and R1234yf is carried out experimentally. A comparative study of AAC performance will be performed for refrigerants R134a and R1234yf. The study will be conducted to analyse the effect of initial refrigerant charge and compressor speed on refrigerant mass flow rate, cooling performance, compressor performance, and Coefficient of Performance (COP).

## 2. Methodology

### 2.1. AAC experimental setup

The AAC test setup is build based on the principle of vapor compression refrigeration system. The four main components of the AAC system are compressors, condensers, expansion valves and evaporators (cooling coils). In the air-conditioning system, the primary working fluid used in the system is the refrigerant and compressor lubricants. This experimental setup was developed for the R134a as the refrigerant. For this experiment, the performance of the AAC system using refrigerants R134a and R1234yf will be compared. The role of the lubricant in the compressor is to protect and reduce the friction between two surfaces that slide together [8]. The PAG ND12 lubricant is used as a lubricant compressor as recommended by the manufacturer. All major components are taken from real vehicles including pipes and expansion valves to ensure the authenticity of the experiment. The main driver of the AAC system which is the internal combustion engine has been replaced with an electric induction motor to drive the compressor. Figure 1 shows the schematic diagram of the experimental test setup. The experimental test setup is connected with the water-cooling system where the evaporator is put inside the insulated calometric water bath. The circulation of the water inside the calometric will act as the heating load to the evaporator of the AAC system. The difference of water inlet and the outlet is used to calculate refrigeration mass flow rate and cooling capacity in accordance to the ASHRAE standard of Standard 41.9-2000: Calorimeter Test Methods for Mass Flow Measurements of Volatile

Refrigerants. The experimental setup will be placed in a special room with constant ambient temperature, which 25 °C with an increment of  $\pm 0.1$  °C and constant humidity.

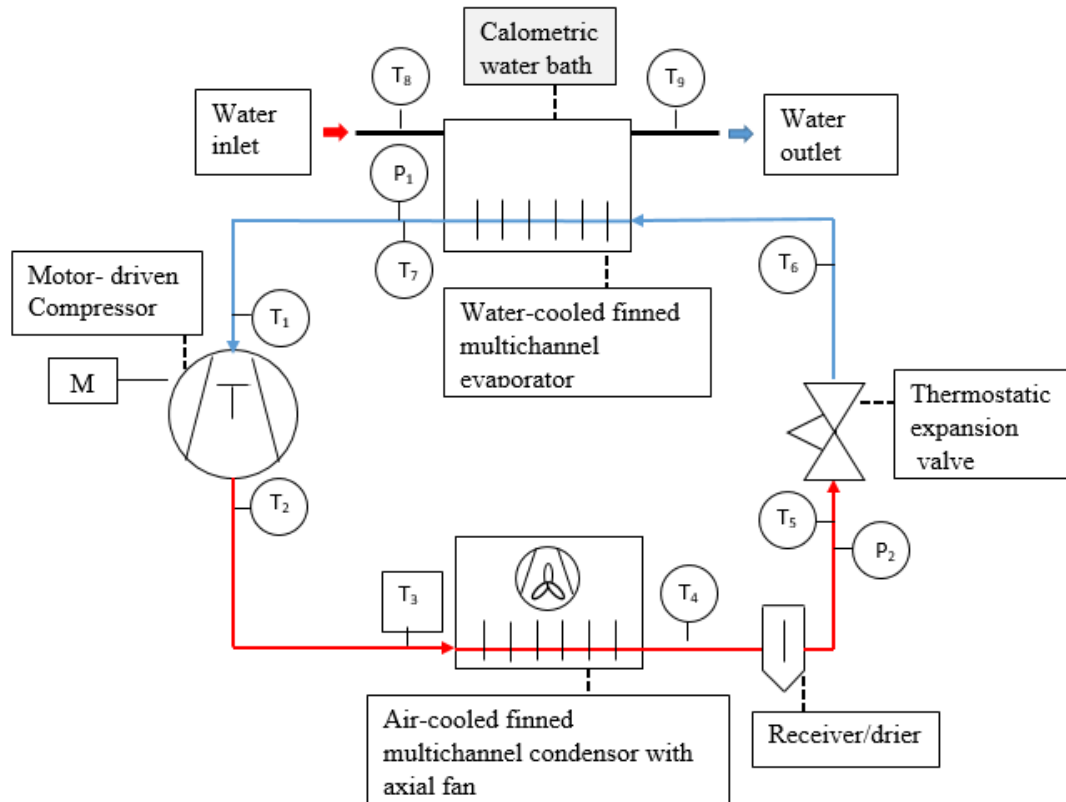

**Figure 1.** Schematic diagram of Automotive Air Conditioning experimental set-up.

## 2.2. Instrumentation and uncertainties

Multiple instruments and sensors are used for measurement purposes in AAC test rig investigations under various working conditions. In the AAC system investigation, important parameters such as pressure and temperature will be recorded. The location of all sensors are shown in figure 1 (Section 2.1). The measurement of temperature and pressure will be taken using T-type thermocouple and pressure sensor. The accuracy of the measuring instrument is illustrated in table 1. Uncertainty for each measuring device is summarized in the table. The temperature and pressure readings will be retrieved and stored in PC using data acquisition tool for analysis purposes.

**Table 1.** The summary for the uncertainties of the experimental parameters.

Parameters	Full scale	Uncertainty
K-type thermocouples, K	233.15 to 648.15	$\pm 1.5$
pressure gauge, psi	0- 200	$\pm 0.1$
Tachometer, rpm	0-20,000	$\pm 2$
water flow meter, LPM	0-100	$\pm 0.1$
Weighing scale, kg	0-25	$\pm 0.001$

### 2.3. Performance analysis of the AAC system

The vapor compression refrigeration system (VCRS) in the air conditioning system works by absorbing heat from refrigerated space and releasing to the surrounding. The compressor will compress the refrigerant to high-pressure gas. Then, the condenser will condense this high-pressure gas refrigerant to high-pressure saturated liquid refrigerant. Later, the expansion valve will change the refrigerant pressure via the throttling process. The pressure reduction process changes the state of the refrigerant from liquid to the gas in which the refrigerant starts to boil. The boiling process happens inside the evaporator and this condition causes the refrigerant to absorb a lot of heat from the cooling medium. The VCRS process include an isentropic compression (reversible adiabatic) in the compressor, heat rejection of constant pressure in the condenser, extension (isenthalpic) expansion in the capillary tubes and the constant pressure heat absorption in the evaporator.

The process of heat absorbs from the cooling medium via the evaporator is calculated from the enthalpy difference of the evaporator inlet and outlet. The heat absorb in the evaporator ( $Q_L$ ) can be calculated as:

$$Q_L = h_1 - h_5 \quad (1)$$

The cooling capacity in the evaporator is the product of the enthalpy difference and the refrigerant mass flow which is calculated as:

$$\dot{Q}_L = \dot{m}_r(h_1 - h_5) \quad (2)$$

The refrigerant mass flow rate,  $\dot{m}_r$  are obtained by using the following relation [9, 10]:

$$\dot{m}_r = \frac{\dot{Q}_{water}}{(h_1 - h_5)} \quad (3)$$

where,

$$\dot{Q}_{water} = \dot{m}_{water}(h_8 - h_9) \quad (4)$$

The indicated work in the compressor is calculated from the enthalpy difference of the compressor inlet and outlet [11]. The compressor work ( $W_{IN}$ ) can be calculated as:

$$W_{IN} = \dot{m}_r(h_2 - h_1) \quad (5)$$

The indicated power in the compressor is the product of the enthalpy difference and the refrigerant mass flow which is calculated as:

$$\dot{W}_{IN} = \dot{m}_r(h_2 - h_1) \quad (6)$$

The coefficient of performance (COP), which is the ratio of the cooling capacity and the compressor power input which is expressed by:

$$COP = \frac{\dot{m}_r(h_1 - h_5)}{\dot{m}_r(h_2 - h_1)} \quad (7)$$

### 2.4. Experimental procedures

Before starting the experiment, all the conditions of the equipment used and the conditions of the test setup must be checked and ensured that all safety precautions were followed before the experiment started. The experimental procedure of the AAC performance investigation will be conducted by following the regulations and recommendations from the standard of SAEJ2765 [12]. The AAC experimental test set-up was vacuum first by using a vacuum pump to remove the moisture and to determine if there are leaks in the system. The compressor lubricant is filled into the compressor with 110 ml. The compressor lubricant used in this experiment is PAG ND12 which specially formulated for

use in R1234yf and R134a AAC system. According to the manufacturer, PAG ND12 are specially formulated to solve several issues regarding the solubility and the higher moisture content of R1234yf refrigerant. The charging machine will be utilized to charge the refrigerant R1234yf and R134a into the AAC system. The desired amount of refrigerant charge is charged into the system. The refrigerant tank will be weighed on a weighing scale to determine the amount of refrigerant charge. The water in the calorimetric water tank was heated up until the temperatures for the inlets and outlets were the same. Then, the experiment started by starting the induction motor with a speed of 900 rpm, which is adjusted by the frequency inverter. The experiment was kept running for 20 minutes and the data reading of temperatures, pressure, power analyzers, and water mass flow rates were taken for 10 minutes after that. The data will be recorded and analyzed. The variables of the following parameters were used to evaluate the response of the AAC system performance which is the compressor speed ( $n$ ) and initial refrigerant charge ( $m_{rc}$ ).

### 3. Results and discussion

#### 3.1. Refrigerant mass flow rate performance of R1234yf vs R134a

Figure 2 presents the experimental data of the refrigerant mass flow rate as a function of the initial refrigerant charge for both R134a and R1234yf AAC system at a various compressor rotational speed. From the data in figure 2, it is apparent that the refrigerant mass flow rate increases with the increment of the initial refrigerant charge. In addition, the compressor speed has a clear effect on the refrigerant mass flow rate. The mass flow rate increases with the increasing compressor speed. These findings further support the theoretical predictions from previous research [13], where they also reported the same trend for the refrigerant mass flow rate in the vapor compression system experiment. A comparison of the two results reveals that the mass flow rate values for R1234yf are up to 12 % higher compared R134a, especially at a higher initial refrigerant charge. The higher refrigerant mass flow rate in R1234yf AAC system is related to the refrigeration system pressure. The compression ratio in inlet and outlet through the compressor for AAC system with R1234yf is smaller than the AAC system with R134a. Therefore, the number of refrigerant specific volume in the compressor inlet is small under the same saturated temperature, thus more refrigerant is released by the compressor in order to achieve equivalent cooling performance [14].

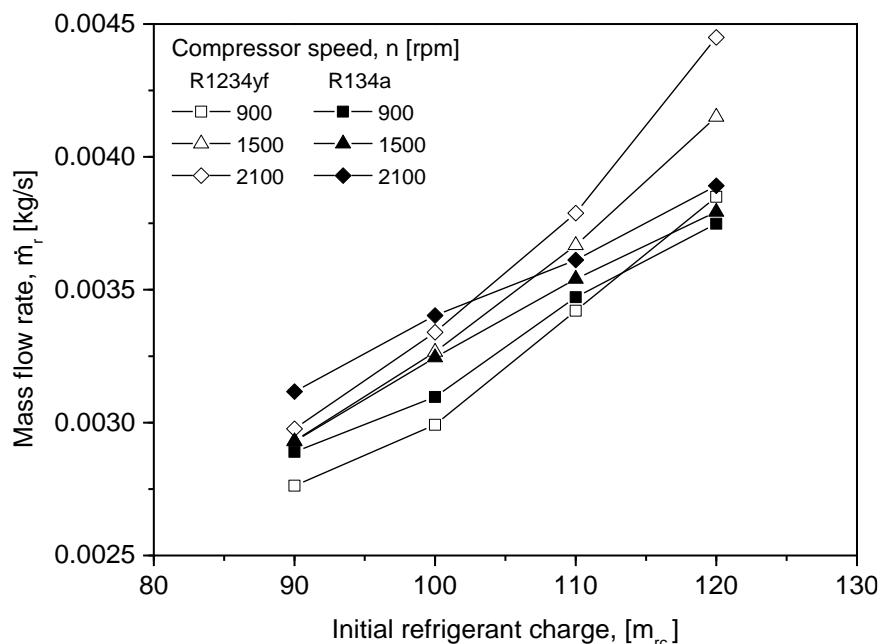
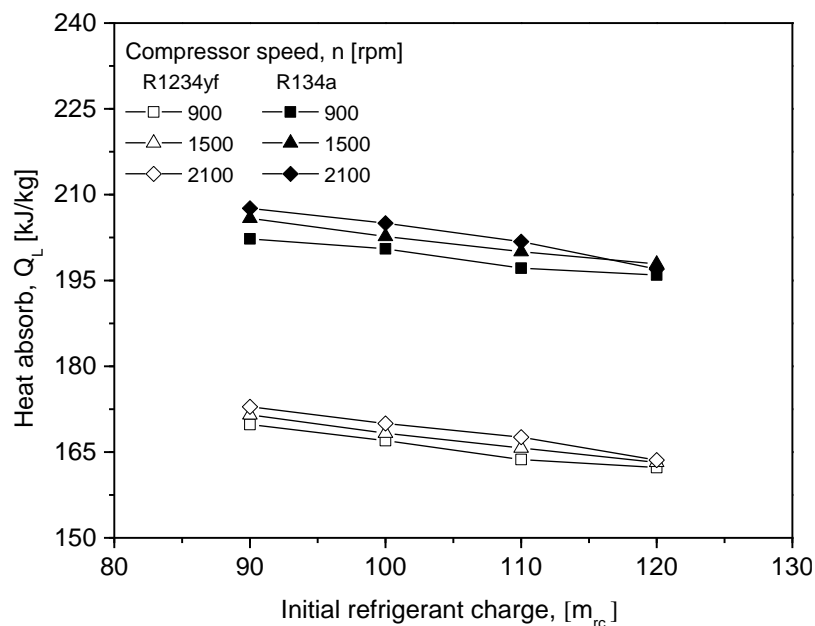

**Figure 2.** Variation of refrigerant flow rate against various initial refrigerant charge.

### 3.2. Cooling performance of R1234yf vs R134a

Figure 3 present the variation of heat absorb against the initial refrigerant charge for different compressor speed. The heat energy differences for the evaporator inlet and outlet show decreasing trend with the initial refrigerant charge and the compressor speed for the both refrigerant. The compressor of the AAC system with a lower initial refrigerant charge undergo starvation due to the lack amount of refrigerant. Due to this condition, the AAC system with an expansion valve system increase the superheat as a feedback mechanism to satisfy the same cooling requirement. Interestingly, the AAC system with R1234yf has a significantly lower heat absorb as compared to R134a AAC system. The possible explanation of this result is related to the properties of latent heat of vaporization. The R1234yf have a slightly lower latent heat of vaporization thus it can absorb less heat energy compared to R134a [15].

Figure 4 shows the experimental results of the cooling capacity against the function of the initial refrigerant charge for refrigerants R134a and R1234yf at various compressor rotational speed. As shown in figure 4, the experimental results show the cooling capacity is in the increasing trend with the initial refrigerant charge. For any initial refrigerant charge, the cooling capacity increases with the compressor speed for both refrigerants. Contrary to the finding in figure 3, the cooling capacity show increment with initial refrigerant charge and compressor speed despite having a reduction in heat absorb. This is due to the mass flow rate, which is shown in figure 2, where the increment in the refrigerant mass flow rate overweight the effect of the evaporator heat absorb reduction. It is also seen that for any refrigerant charge and compressor speed value, the cooling capacity of the R134a AAC system has a significantly higher cooling capacity (from 5 to 25 %) than the R1234yf AAC system. This result may be due to the higher heat absorb value as shown in figure 3 which help the evaporator absorb more heat and provides a better cooling effect in the R134a AAC system.



**Figure 3.** Heat absorb per unit mass of R1234yf and R134a AAC system as a function of initial refrigerant charge.

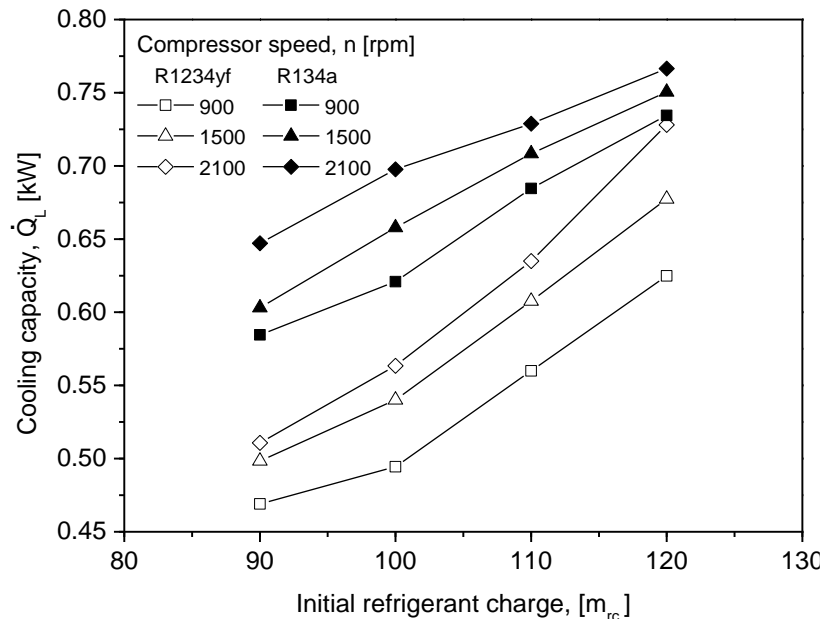
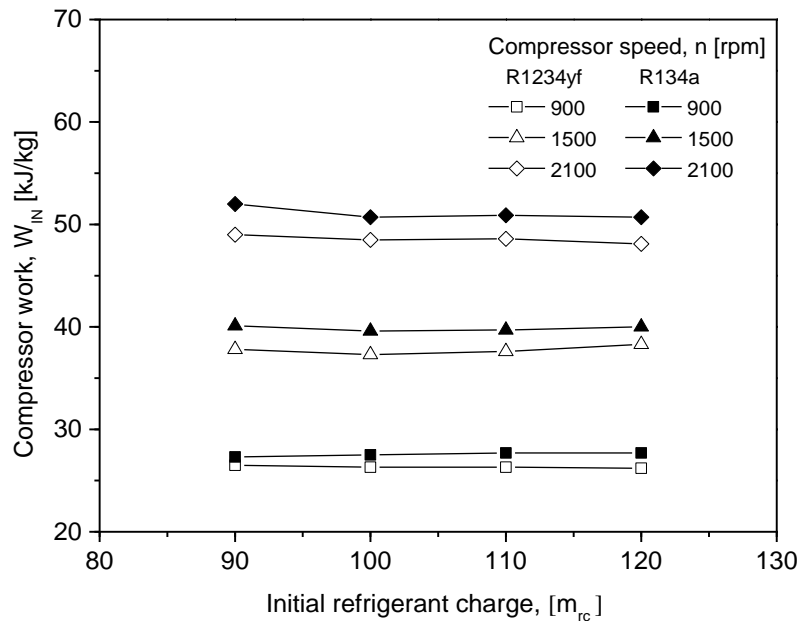

**Figure 4.** Cooling capacity per unit mass of R1234yf and R134a AAC system as a function of initial refrigerant charge.

### 3.3. Compressor performance of R1234yf vs R134a

The indicated compressor work and compressor powers for the same set of experiments are shown in figure 5 and figure 6, respectively. Figure 5 shows the compressor work is in an increasing trend with the compressor speed, for both refrigerants. The compressor at high speeds tends to work much harder than at low speeds, and subsequently reduces its efficiency. However, the compressor work shows no obvious changes with the increment of the initial refrigerant charge. It is interesting to note that the R1234yf AAC system requires lower compressor work compared to R134a AAC system. On the compressor indicated power data analysis of the AAC experiment, this study found that compressor indicated powers increase with increasing values the initial refrigerant charge and compressor speed as shown in figure 6. Previously, theoretical analysis from the previous study has already shown that the refrigerant cycle predicts the isentropic compressor power to increase with the initial refrigerant charge and compressor speed [13]. The increment of the compressor power is due to the rise in the refrigerant mass flow rate, which is shown in figure 2. Finally, a comparison between the experimental results for R134a and R1234yf show a clear effect on the compressor indicated power. The experimental values for the compressor indicated power is slightly lower (up to 11 %) for the AAC system with R1234yf compared to R134a. As noted in another study, R1234yf AAC system has a lower compressor ratio due to the influence if the thermodynamic characteristic thus the compressor work and compressor power are lower compare to R1234yf AAC system [14].





**Figure 5.** Compressor per unit mass of R1234yf and R134a AAC system as a function of initial refrigerant charge.

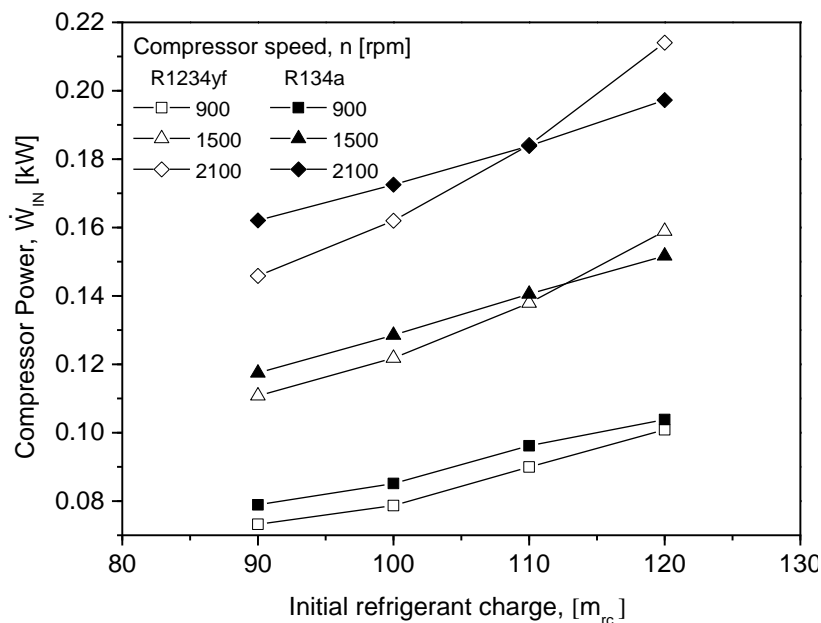
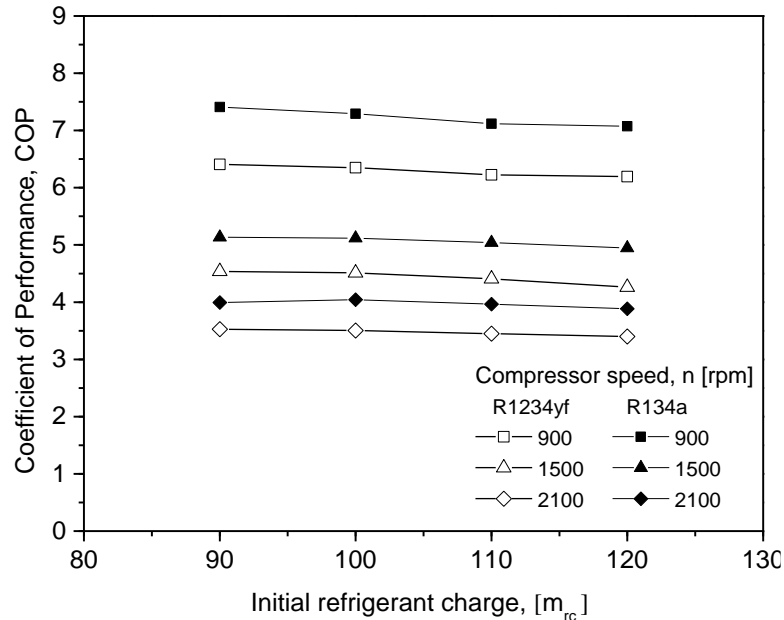

**Figure 6.** Compressor indicated power per unit mass of R1234yf and R134a AAC system as a function of initial refrigerant charge.

### 3.4. Coefficient of performance of R1234yf vs R134a

Figure 7 compares the experimental data of COP for the same cases considered in the previous figures. From the graph, there are no obvious changes in COP increment of the initial refrigerant charge. As expected, there is a decrement trend in the COP value with the increasing compressor speed. This is due to the high compressor work and compressor power (as shown in figure 5 and figure 6) with the compressor speed, that outweighs the increment of the heat absorb and cooling capacity in COP calculation. Finally, the experimental results reveal that, under the same operating conditions, the COP of R1234yf AAC system is always lower than with R134a (14.5 % on average). The findings of the

current study are consistent with the previous study where the author found the same finding regarding the trends of COP inside the refrigeration system operating with R1234yf [6, 13, 14].



**Figure 7.** COP of R1234yf and R134a AAC system as a function of initial refrigerant charge.

#### 4. Conclusion

The performance of the AAC system operating with R1234yf and R134a refrigerant were analysed and compared. The study was carried out by analysing the effect of initial refrigerant charge and compressor speed on the heat absorb, cooling capacity, compressor work, compressor power, and coefficient of performance. In this study, there is a notable difference in term of performance between R1234yf and R134a operating inside AAC system. A comparison of the two results reveals the mass flow rate values for refrigerant R1234yf are up to 12 % higher than the R134a at a higher initial refrigerant charge. The AAC system with the R1234yf has a significantly lower heat absorb as compared to the R134a AAC system. It is also noticed that for any refrigerant charge and compressor speed value, the cooling capacity of the R1234yf AAC system has a significantly lower cooling capacity (from 5 to 25 %) than the R134a system. However, the compressor work shows no obvious changes with the increment of the initial refrigerant charge. Interestingly, the experimental values for the compressor indicated power is slightly lower (up to 11 %) for the R1234yf compared to the R134a operating inside the AAC system. Finally, the experimental results reveal that, under the same operating conditions, the COP of the R1234yf AAC system is always lower (14.5 % on average) compared to the R134a AAC system. Nevertheless, a detailed optimization procedure is recommended in order to reduce the gap in term of performance of the AAC system operating with R1234yf refrigerant.

#### Acknowledgments

The authors are grateful to the Universiti Malaysia Pahang (UMP) for financial supports given under PGRS190335.

#### References

- [1] Calm J M 2008 The next generation of refrigerants—Historical review, considerations, and outlook *international Journal of Refrigeration* **31** 1123-33

- [2] Manoj V, Balamurugan V and Kumar B S 2016 A Review on selecting an eco-friendly refrigerant alternate to R134a in domestic refrigerators *International Journal of Science, Engineering and Technology Research* **5** 2992-9
- [3] Koban M 2009 HFO-1234yf low GWP refrigerant LCCP analysis *SAE Technical Paper* **2009** 1-5
- [4] Park K-J, Lee Y-H, Choe D-S and Jung D-S 2010 Performance of R1234yf and R1234yf/R134a mixture under mobile air-conditioner operating conditions *Korean Journal of Air-Conditioning and Refrigeration Engineering* **22** 837-44
- [5] Chen J, Zhao Y and Qi Z 2011 New developments in mobile air conditioning systems in China *Frontiers of Energy and Power Engineering in China* **5** 53-8
- [6] Lee Y and Jung D 2012 A brief performance comparison of R1234yf and R134a in a bench tester for automobile applications *Applied Thermal Engineering* **35** 240-2
- [7] Minor B and Spatz M 2008 HFO-1234yf low GWP refrigerant update
- [8] Zawawi N N M, Azmi W H, Redhwan A A M, Sharif M Z and Samykano M 2018 Experimental investigation on thermo-physical properties of metal oxide composite nanolubricants *International Journal of Refrigeration* **89** 11-21
- [9] Sharif M Z, Azmi W H, Zawawi N N M, Mamat R and Shaiful A I M 2019 Energy and exergy analysis of compact automotive air conditioning (AAC) system. In: *IOP Conference Series: Materials Science and Engineering*: IOP Publishing) p 012042
- [10] Redhwan A A M, Azmi W H, Sharif M Z, Mamat R, Samykano M and Najafi G 2019 Performance improvement in mobile air conditioning system using Al<sub>2</sub>O<sub>3</sub>/PAG nanolubricant *Journal of Thermal Analysis and Calorimetry* **135** 1299-310
- [11] Redhwan A A M, Azmi W H, Sharif M Z and Hagos F Y 2017 Development of nanolubricant automotive air conditioning (AAC) test rig. In: *MATEC web of conferences*: EDP Sciences) p 01050
- [12] SAEJ2765 S I S 2008 SAE J2765 - Procedure for Measuring System COP [Coefficient of Performance] of a Mobile Air Conditioning System on a Test Bench. SAE internationals) p 20
- [13] Sieres J and Santos J M 2018 Experimental analysis of R1234yf as a drop-in replacement for R134a in a small power refrigerating system *International Journal of Refrigeration* **91** 230-8
- [14] Cho H, Lee H and Park C 2013 Performance characteristics of an automobile air conditioning system with internal heat exchanger using refrigerant R1234yf *Applied Thermal Engineering* **61** 563-9
- [15] Wang C-C 2014 System performance of R-1234yf refrigerant in air-conditioning and heat pump system—An overview of current status *Applied Thermal Engineering* **73** 1412-20