

FINITE ELEMENT ANALYSIS USING A HIERARCHAL DECOMPOSITION FOR THE INTERACTION OF STRUCTURE, FLUID AND ELECTROSTATIC FIELD IN MEMS

D. ISHIHARA^{*}, T. HORIE^{*}, T. NIHO^{*} AND A. BABA[†]

^{*} Department of Mechanical Information Science and Technology
Kyushu Institute of Technology
680-4 Kawazu, Iizuka, Fukuoka 820-8502, Japan
e-mail: ishihara@mse.kyutech.ac.jp

[†]Center for Microelectronic System (CMS)
Kyushu Institute of Technology
680-4 Kawazu, Iizuka, Fukuoka 820-8502, Japan

Key words: Structure-Fluid-Electric Interaction, Decomposition, Partitioning, Splitting, Finite Element Analysis, Micro-Electro-Mechanical System (MEMS).

Abstract. In this study, a hierarchal decomposition for the interaction of the structure, fluid and electrostatic field or the structure-fluid-electrostatic interaction, which is one of typical phenomena in micro-electro-mechanical system (MEMS), is proposed in order to solve it efficiently. The proposed decomposition partitions the structure-fluid-electrostatic interaction into the fluid-structure interaction (FSI) and the electrostatic field, and, moreover, splits the FSI into the velocity and fluid pressure fields. In this way, the whole interaction system is decomposed into the three fields in a hierarchal way. The proposed decomposition is implemented using a finite element method and is applied to a micro cantilever beam actuated by the electrostatic force in air. It follows from the comparison among the results for the structure-fluid-electrostatic interaction, the FSI and the experiment that the proposed method taking into account the full-interaction can predict the vibration characteristic of the MEMS accurately.

1 INTRODUCTION

MEMS are typically smaller than 1 millimeter and larger than 1 micrometer in size. At these size scales, the surface forces are superior to the body forces due to the scale effect. Therefore, MEMS are typically driven by the electrostatic force, and their vibrations are damped significantly due to the fluid viscous force from air. In addition, both the electrostatic and fluid viscous forces are sensitive to the structural behavior. Therefore, the structure-fluid-electrostatic interaction is one of typical phenomena in MEMS. Vibration characteristics such as the resonance frequency and the damping ratio are the key design parameters, and the interaction analysis is required in order to predict them accurately [1, 2].

In this study, a finite element analysis for the structure-fluid-electrostatic interaction is proposed. The proposed analysis consists of the partitioned analysis, where the structure-fluid-electrostatic interaction is partitioned into the FSI and the electrostatic field, and the

monolithic analysis for the FSI. Moreover, the monolithic FSI system is solved using a projection method [5, 6, 7], where the FSI is split into the velocity and fluid pressure fields. Its application can be seen in [8, 9]. The decomposition used in the proposed analysis consists of the partitioning and the splitting in a hierarchal way. Therefore, it is called as the hierarchal decomposition.

The proposed analysis is applied to the micro cantilever beam driven by the electrostatic force in air. It is demonstrated from the comparison among the results for the structure-fluid-electrostatic interaction, the FSI, and the experiment that the proposed analysis taking into account the full interaction can predict the dynamic behavior of MEMS accurately.

2 FINITE ELEMENT ANALYSIS USING HIERARCHAL DECOMPOSITION

2.1 Finite element discretized equations

The finite element discretized equilibrium equation system for the structure-fluid-electrostatic interaction is schematically written as

$$\mathbf{Q}^s + \mathbf{Q}^f = \mathbf{g}^e, \quad (1)$$

where \mathbf{Q} is the equivalent internal force vector including all effects such as the structural and fluid inertia, the structural elasticity, the fluid diffusion, and the fluid pressure gradient, \mathbf{g} is the external force vector, and the superscripts s, f and e denote the quantities corresponding to the structure, the fluid, and the electrostatic field, respectively. Since MEMS can undergo large deformation, the finite deformation is taken into account using the total Lagrangian formulation, where the Hooke's law is used for the relation between the second Piola-Kirchhoff stress and the Green-Lagrange strain under the assumption of small strain. The fluid is assumed to be Newtonian.

The electrostatic force \mathbf{g}^e is the nonlinear function with respect to the structural displacement vector \mathbf{u}^s . In the present study, \mathbf{g}^e is obtained as follows: The electrostatic potential ϕ is obtained from the Laplace equation with the boundary including the structural surface. Next, the electrostatic field \mathbf{E} is given by the gradient of ϕ . Finally, \mathbf{g}^e is obtained as

$$\mathbf{g}^e = -(\varepsilon/2)(\mathbf{E} \cdot \mathbf{n})^2 \mathbf{n}, \quad (2)$$

where ε is the dielectric constant, \mathbf{n} is the unit vector outward normal to the structural surface.

2.2 Coupled analysis using hierarchal decomposition

In order to partition the structure-fluid-electrostatic interaction into the FSI and the electrostatic field, Eq. (1) is evaluated as

$${}^{t+\Delta t}\mathbf{Q}^s (k+1) + {}^{t+\Delta t}\mathbf{Q}^f (k+1) = \mathbf{g}^e ({}^{t+\Delta t}\mathbf{u}^s (k)), \quad (3)$$

where the superscript $t+\Delta t$ denotes the current time step, and the superscript k with the round brackets denotes the iteration at the current time step. After deriving the electrostatic force \mathbf{g}^e using the previous structural displacement ${}^{t+\Delta t}\mathbf{u}^s (k)$, Eq. (3) can be solved monolithically.

Moreover, the FSI is split into the velocity and pressure fields using a projection method [5, 6, 7]. In this way, the structure-fluid-electrostatic interaction is decomposed into the three fields in a hierarchical way. Therefore, the proposed decomposition is called as the hierarchical decomposition.

The predictor multi-corrector algorithm based on the Newmark's method is used for the time integration. Fig. 1 shows the analysis flow of the proposed analysis.

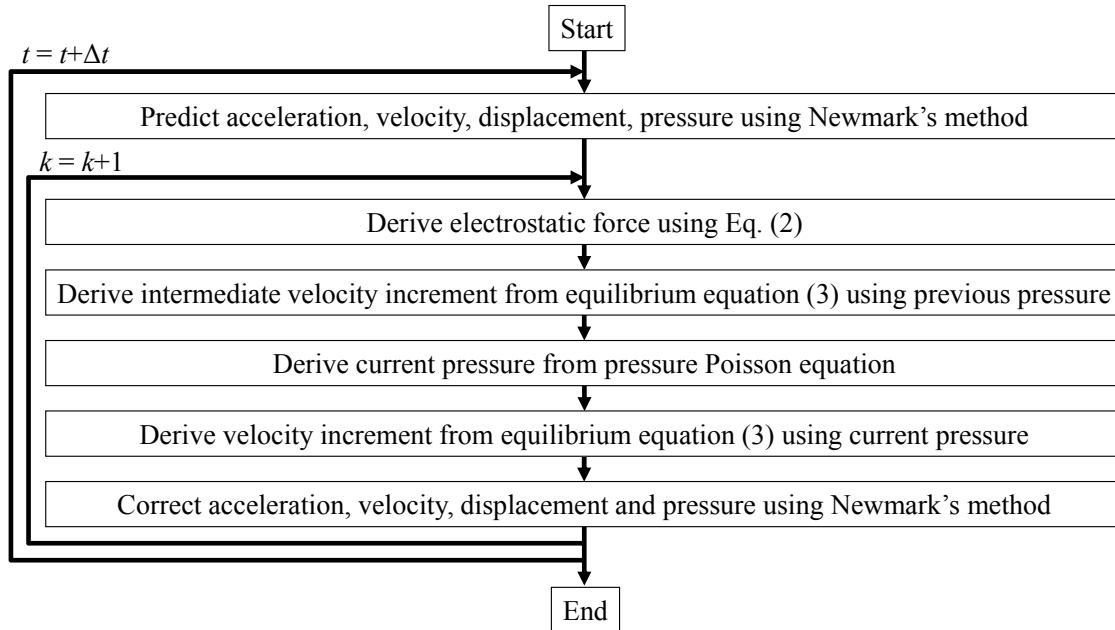

Figure 1: Analysis flow of the proposed method.

3 NUMERICAL EXAMPLE

3.1 Problem setup

The present problem is schematically shown in Fig. 2. A micro cantilever beam is made using a chemical etching for the SOI wafer (the upper and bottom layers are made of arsenic-doped Si and conductive, while the middle layer is made of SiO₂ and isolated). The step voltage is applied between the beam (the upper layer) and the base (the bottom layer). The beam has the dimensions of the length $L = 1.00 \times 10^3 \mu\text{m}$, the width $W = 36 \mu\text{m}$, the thickness $H = 3.0 \mu\text{m}$ and the gap $G = 5.0 \mu\text{m}$, which are identified using the SEM images.

The structural mass density ρ^s is assumed to be equal to that of the bulk material of Si 2328 kg/m³. The Poisson's ratio ν is assumed to be 0 [3]. Since the Young's modulus E is usually different from that of the bulk material of Si due to the scale effect, it is evaluated as follows: The natural frequency of the beam is evaluated from the experimental result of its free vibration in vacuum (under 2 Pa). Then, E is evaluated using the natural frequency from the experiment and its theoretical solution under the assumption of the Euler-Bernoulli beam. E is evaluated as 184.2 GPa, which is consistent with that in the previous study [4]. The material properties of air (26 degrees C) are the mass density $\rho^s = 1.18 \times 10^{-3} \text{ g/cm}^3$ and the viscosity $\mu = 1.82 \times 10^{-4} \text{ g/(cm sec)}$. The dielectric constant of air is $8.859 \times 10^{-12} \text{ F/m}$.

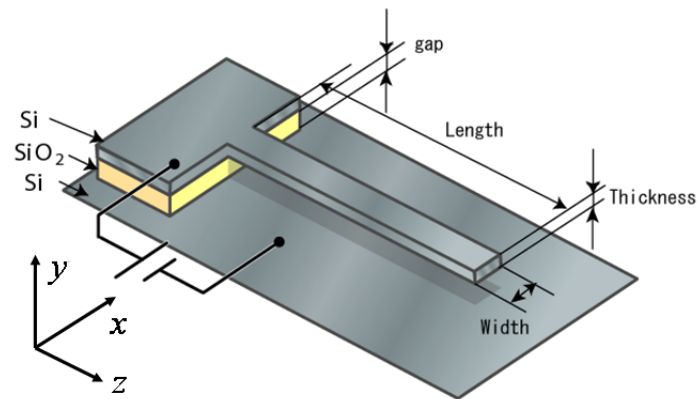

Figure 2: Schematic view of the problem setup. The micro cantilever beam is driven and vibrated by the electrostatic force generated by the step voltage between the beam and the base.

Each voltage to the chip is supplied by the high speed DC power supply (the risetime is approximately $50\mu\text{sec}$). The velocity in the y -direction of the free end of the beam is measured using the laser Doppler vibrometer (Ono Sokki Co., Ltd., Japan). The data of the supplied voltage and the velocity of the beam are simultaneously collected using a data acquisition system with a sampling speed of $500,000\text{Hz}$. The former is used to obtain the applied voltage between the beam and the base, and the latter is used for the validation of the present numerical results. The time histories of the maximum applied voltages are shown in Fig. 3.

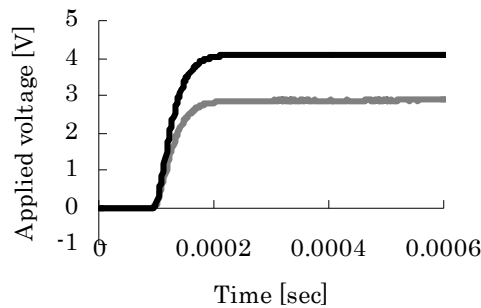

Figure 3: Time histories of the maximum applied voltages. The black line indicates the applied voltage in air, while the gray line indicates that in vacuum.

The symmetry with respect to the y - z plane is taken into account for the analysis domain. The mesh for the structural domain consists of 661 nodes and 240 elements, where the quadratic hexahedral elements (20 nodes) are used, the mesh for the fluid domain consists of 5,916 nodes and 26,698 elements, where the linear tetrahedral elements (4 nodes) are used, and the mesh for the electrostatic field domain consists of 195 nodes and 480 elements, where the linear tetrahedral elements (4 nodes) are used. The time increment used in the numerical analyses is $1\mu\text{sec}$.

3.2 Results and discussion

Fig. 4 shows the time histories of the velocity in the y-direction of the free end of the beam for the applied voltage in Fig. 3. As shown in this figure, the air damping was significant. Therefore, the FSI must be taken into account in the present problem. Fig. 4 also shows the necessity of the full interaction analysis. As shown in this figure, the numerical result for the structure-fluid-electrostatic interaction was consistent with the experimental result, while the numerical result for the FSI was inconsistent with the other results. The vibration from the full interaction analysis was over-damping, while that from the FSI analysis was under-damping. This qualitative difference was caused by the high sensitivity of damping to the gap. At equilibrium, the displacement from the full interaction analysis was $-1.36\mu\text{m}$, while that from the FSI analysis was $-0.899\mu\text{m}$. Therefore, the damping in the full interaction analysis was far larger than that in the FSI analysis.

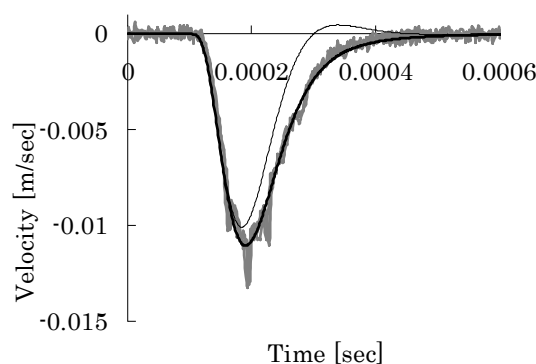

Figure 4: Time histories of the y-velocity of the free end of the micro cantilever beam for the applied voltage in Fig.3. The black line indicate the numerical result for the structure-fluid-electrostatic interaction, and the narrow black line indicates the numerical result for the FSI, while the gray line indicates the experimental result in air.

4 CONCLUSIONS

In the present study, the finite element analysis using the hierarchal decomposition was proposed in order to solve the structure-fluid-electric interaction. The proposed analysis was applied to the micro cantilever beam driven by the electrostatic force in air. It follows from the comparison among the results for the structure-fluid-electrostatic interaction, the FSI, and the experiment that the proposed analysis taking into account the full-interaction can predict the MEMS dynamic behavior accurately.

ACKNOWLEDGEMENT

This work was supported by JSPS KAKENHI 26390133.

REFERENCES

- [1] De SK, Aluru NR. Coupling of hierarchical fluid models with electrostatic and mechanical models for the dynamic analysis of MEMS. *Journal of Micromechanics and Microengineering* 2006;16:1705-1719.

- [2] Ghosh R, Mukherjee S. Fully Lagrangian modeling of dynamics of MEMS with thin beams-part 2: undamped vibration. *Journal of Applied Mechanics* 2009;76:051008.
- [3] Namazu T, Tanaka M, Inoue S. A simple determination method of in-plane Poisson's ratio for MEMS materials by means of on-chip pure bending test. *Proceedings of 20th IEEE International Conference on Micro Electro Mechanical Systems* 2007; 235-238.
- [4] Sato K, Yoshioka T, Ando T, Shikida M, Kawabata T. Tensile testing of silicon film having different crystallographic orientations carried out on a silicon chip. *Sensors and Actuators A* 1998;70:148-152.
- [5] Ishihara D, Horie T. A projection method for the interaction of an incompressible fluid and a structure using new algebraic splitting. To appear in *Computer Modeling in Engineering and Sciences*.
- [6] Ishihara D, Yoshimura S. A monolithic approach for interaction of incompressible viscous fluid and an elastic body based on fluid pressure Poisson equation. *International Journal for Numerical Methods in Engineering* 2005;64:167-203.
- [7] Ishihara D, Kanei S, Yoshimura S, Horie T. Efficient parallel analysis of shell-fluid interaction problem by using monolithic method based on consistent pressure Poisson equation. *Journal of Computational Science and Technology* 2008;2(1):185-196.
- [8] Ishihara D, Horie T, Denda M. A two dimensional computational study on fluid-structure interaction cause of wing pitch changes in dipteran flapping flight. *The Journal of Experimental Biology* 2009;212:1-10.
- [9] Ishihara D, Horie T, Niho T. An experimental and three-dimensional computational study on the aerodynamic contribution to the passive pitching motion of flapping wings in hovering flies. *Bioinspiration and Biomimetics* 2014;9(4):046009(23pp).