



**National
Oceanography Centre**

NATURAL ENVIRONMENT RESEARCH COUNCIL

National Oceanography Centre

Cruise Report No. 32

RRS James Cook Cruise JCI20

15 APR - 19 MAY 2015

Manzanillo to Manzanillo, Mexico

Managing Impacts of Deep-sea resource exploitation (MIDAS)

Clarion-Clipperton Zone

North Eastern Area of Particular Environmental Interest

Principal Scientist

D O B Jones

2015

National Oceanography Centre, Southampton
University of Southampton Waterfront Campus
European Way
Southampton
Hants SO14 3ZH
UK

Tel: +44 (0)23 8059 6257

Email: djl@noc.ac.uk



DOCUMENT DATA SHEET

| | |
|----------------------------------------------------------------------------------------------------------------------------------------------------------------------------------------------------------------------------------------------------------------------------------------------------------------------------------------------------------------------------------------------------------------------------------------------------------------------------------------------------------------------------------------------------------------------------------------------------------------------------------------------------------------------------------------------------------------------------------------------------------------------------------------------------------------------------------------------------------------------------------------------------------------------------------------------------------------------------------------------------------------------------------------------------------------------------------------------------------------------------------------------------------------------------------------------------------------------------------------------------------------------------------------------------------------------------------------------------------------------------------------------------------------------------------------------------------------------------------------------------------------------------------------------------------------------------------------------------------------------------------------------------------------------------------------------------------------------------------------------------------------------------------------------------------------------------------------------------------------------------------------------------------------------------------------------------------------------------------------------------------------------------------------------------------------------------------------------------------------------------------------------------------------------------------------------------------------------------------------------------------------------------------------------------------------------------------------------------------|---------------------------------|
| <i>AUTHOR</i> JONES, D O B et al | <i>PUBLICATION DATE</i> 2015 |
| <i>TITLE</i> RRS <i>James Cook</i> Cruise JC120, 15 Apr - 19 May 2015. Manzanillo to Manzanillo, Mexico. Managing Impacts of Deep-seA resource exploitation (MIDAS): Clarion-Clipperton Zone, North Eastern Area of Particular Environmental Interest. | |
| <i>REFERENCE</i> Southampton, UK: National Oceanography Centre, Southampton, 117pp. (National Oceanography Centre Cruise Report, No. 32) | |
| <i>ABSTRACT</i> <p>RRS <i>James Cook</i> Cruise JC120 was part of the Managing Impacts of Deep-seA resource exploitation (MIDAS) European Union Framework Programme 7 Project. It was jointly funded by the UK Natural Environment Research Council</p> <p>JC120 was the first UK science cruise to the Clarion Clipperton Zone (CCZ) in the northern equatorial Pacific, an area likely to be targeted for deep-sea mining for polymetallic nodules. This cruise visited the north easternmost Area of Particular Environmental Importance (APEI). There are a total of nine of these APEIs situated to the north and south of the mining claim areas defined by the International Seabed Authority (ISA) across the CCZ. The APEIs have been delineated by the ISA as part of their environmental management plan for the CCZ and are designed to protect representative species and habitats for the CCZ. The APEIs have been designed based on surface ocean characteristics and the topography of the seafloor, estimated from satellite altimetry. At present there has been virtually no sampling of seafloor habitats or species in the APEIs. The NERC cruise aimed to change that. The cruise studied a representative area of the APEI in great detail at high resolution and over a variety of scales. This characterised the habitats, biology, physical and chemical conditions - adding important information about the CCZ in general and making a detailed baseline assessment for this area, which can be compared to other sites and used as a barometer of change in the deep sea associated with mining activities.</p> <p>The NERC cruise JC120 used a variety of tools for assessment of this >4000m deep area of the CCZ. Shipboard mapping of depth and backscatter were carried out (EM12). The autonomous underwater vehicle (AUV) Autosub6000 carried out wide-area acoustic surveys (Edgetech Side-scan sonar, EM2040 Multibeam Bathymetry and sub-bottom profiler), collected seabed photographs and made physical measurements of the water column of the APEI. There were also more detailed HD video and photographic surveys of the seafloor using the HyBIS vehicle. Sediment samples (megacore, boxcore and gravity core), water samples (CTD) and biological samples (Agassiz Trawl) were also collected.</p> | |
| <i>KEYWORDS</i> | |
| <i>ISSUING ORGANISATION</i> National Oceanography Centre University of Southampton Waterfront Campus European Way Southampton SO14 3ZH UK Tel: +44(0)23 80596116 Email: nol@noc.soton.ac.uk <i>A pdf of this report is available for download at: http://eprints.soton.ac.uk</i> | |

Page intentionally left blank

JC120 Cruise Report

Contents

| | |
|-----------------------------------------------------------------|----|
| Scientific Personnel | 7 |
| Ship's Personnel..... | 8 |
| Itinerary..... | 9 |
| Track Chart | 9 |
| Background..... | 9 |
| List of equipment used..... | 11 |
| Narrative | 12 |
| Geophysical data processing..... | 29 |
| Shipboard EM120 Multibeam Bathymetry (191 beams)..... | 29 |
| Shipboard EM120 Multibeam Backscatter (12kHz)..... | 32 |
| Shipboard SBP120 sub-bottom profiler (2.5-6.5 kHz) | 33 |
| Autosub EM2000 Multibeam Bathymetry (256 beams)..... | 34 |
| Autosub EM2040 Multibeam Backscatter (200 - 300 - 400kHz) | 36 |
| Autosub Edgetech low frequency Sidescan (120kHz)..... | 38 |
| Autosub Edgetech high frequency Sidescan (410kHz)..... | 39 |
| Autosub EdgeTech Chirp profiler (2-13 kHz sweep) | 41 |
| Survey design..... | 44 |
| APEI-4 Study areas..... | 44 |
| Sampling locations..... | 44 |
| Hydraulic Benthic In Situ Sampler (HyBIS) | 46 |
| Camera Setup..... | 48 |
| HyBIS dives | 48 |
| Autosub6000 | 56 |
| Image collection..... | 56 |
| AUV Missions | 59 |
| Amphipod Trap..... | 66 |
| Agassiz Trawl | 69 |
| Coring | 70 |
| Megacorer | 70 |

| | |
|------------------------------------------------|-----|
| Box Coring..... | 78 |
| Macrofaunal Genetics | 83 |
| Aims & General Summary of Work completed..... | 83 |
| Methods | 84 |
| Preliminary Results..... | 89 |
| Further Work..... | 91 |
| Lessons Learnt & Suggested Improvements..... | 91 |
| Other Notes | 92 |
| Meiofauna analysis (benthic foraminifera)..... | 93 |
| General aim..... | 93 |
| Sampling and analyses..... | 93 |
| Quantitative meiofauna..... | 93 |
| Meiofauna DNA..... | 94 |
| Additional material | 94 |
| Preliminary results | 95 |
| Megacore samples for eDNA..... | 99 |
| CTD sampling for eDNA..... | 99 |
| Geochemistry Group Sampling and Methods..... | 102 |
| Water column sampling | 102 |
| Sediment sampling..... | 102 |
| Mn-nodule sampling..... | 107 |
| References..... | 111 |
| Acknowledgements..... | 111 |
| Appendix 1: JC120 Station list | 112 |

Scientific Personnel

| | | |
|---------------------------|---------------------|-----------------------------------------------|
| Daniel Jones | Principal Scientist | National Oceanography Centre, OBE |
| James Bell | Scientist | University of Leeds & Natural History Museum, |
| Brian Bett | Scientist | National Oceanography Centre, OBE |
| Clemence Cauille | Scientist | University of Angers, France |
| Douglas Connelly | Scientist | National Oceanography Centre, MG |
| Jennifer Durden | Scientist | University of Southampton and NOC, OBE |
| Janine Felden | Scientist | Pangaea, Germany |
| Andrew Gates | Scientist | National Oceanography Centre, OBE |
| Veerle Huvenne | Scientist | National Oceanography Centre, MG |
| Pierre Josso | Scientist | University of Southampton |
| Claire Laguionie-Marchais | Scientist | National Oceanography Centre, OBE |
| Anna Lichtschlag | Scientist | National Oceanography Centre, MG |
| Amaya Menendez | Scientist | University of Southampton and NOC, MG |
| Kate Peel | Scientist | National Oceanography Centre, MG |
| Kathleen Robert | Scientist | National Oceanography Centre, MG |
| Natalia Shulga | Scientist | Shirshov Institute of Oceanography, Moscow |
| Erik Simon | Scientist | University of Southampton and NOC, OBE |
| Sergio Taboada | Scientist | Natural History Museum, London |
| C. Robert Young | Scientist | National Oceanography Centre, OBE |
| Andrew Webb | Tech | National Oceanography Centre, MARS |
| Martin Bridger | SST | National Oceanography Centre, NMF |
| David Turner | Tech | National Oceanography Centre, MARS |
| Benjamin Poole | Tech | National Oceanography Centre, NMF |
| James Perrett | Tech | National Oceanography Centre, MARS |
| Ella Richards | Tech | National Oceanography Centre, MARS |
| Daniel Roper | Tech | National Oceanography Centre, MARS |
| David Edge | Tech | National Oceanography Centre, MARS |
| Rachel Marlow | Tech | National Oceanography Centre, MARS |
| Antonio Campos | Tech | National Oceanography Centre, MARS |
| Howard King | Tech | National Oceanography Centre, NMF |

Ship's Personnel

| | |
|------------------|--------|
| John Leask | Master |
| Richard Warner | C/O |
| Stewart Mackay | 2/O |
| Richard Vaughan | 3/O |
| Robert Brett | Ch.Eng |
| Christopher Kemp | 2/E |
| Noel Doherty | 3/E |
| Gary Slater | 3/E |
| Paul Damerell | ETO |
| Graham Bullimore | PCO |
| John Macdonald | CPOS |
| Steven Duncan | POD |
| Dean Anderson | ERPO |
| John Hopley | POD |
| Stephen Toner | SG1A |
| Adam Osborne | SG1A |
| Graham Bartlett | SG1A |
| Simon Wilcox | SG1A |
| John Haughton | H/Chef |
| Walter Link | Chef |
| Paul Marler | Stwd |
| Kevin Osborne | A/Stwd |

Itinerary

Port of mobilisation of equipment: Port of Spain, Trinidad (left 31 March 2015)

Departure: Manzanillo, Mexico 15 April 2015

Arrival: Manzanillo, Mexico 19 May 2015

Number of days: 34

Track Chart

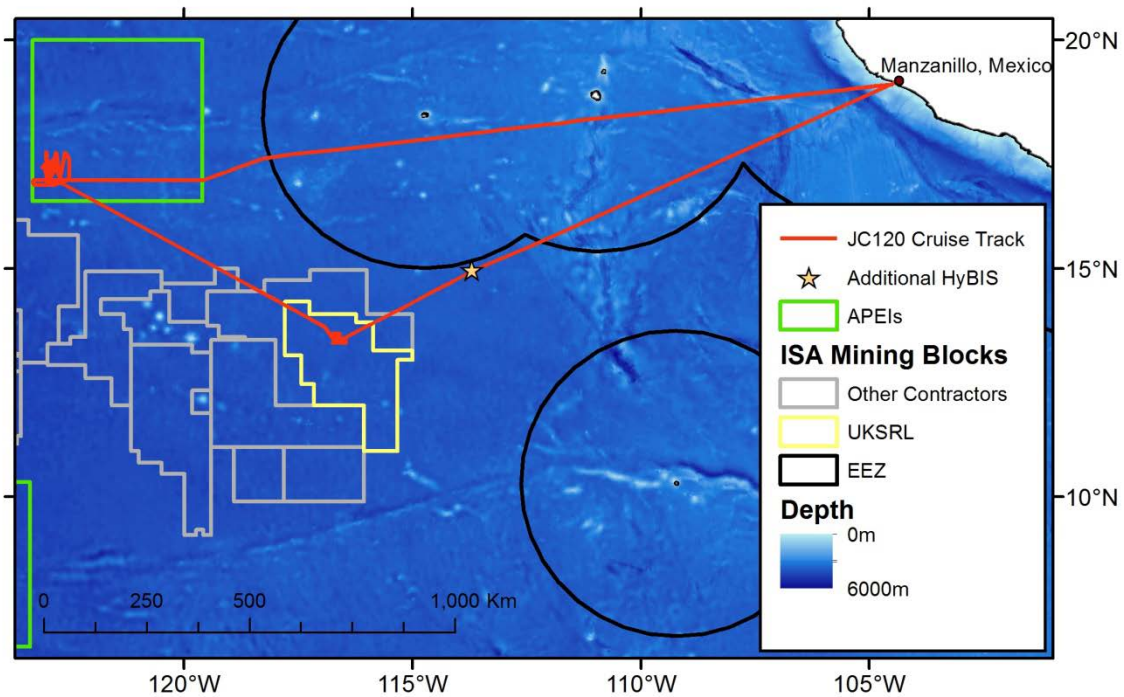

Background

This cruise is part of the Managing Impacts of Deep-sea resource exploitation (MIDAS) European Union Framework Programme 7 Project. It was jointly funded by the UK Natural Environment Research Council.

This is the first UK cruise to the Clarion Clipperton Zone (CCZ) in the northern equatorial Pacific, an area likely to be targeted for deep-sea mining for polymetallic nodules. This cruise will visit the north easternmost Area of Particular Environmental Importance (APEI). There are a total of nine of these APEIs situated to the north and south of the mining claim areas defined by the International Seabed Authority (ISA) across the CCZ. The APEIs have been delineated by the ISA as part of their environmental management plan for the CCZ and are designed to protect representative species and habitats for the CCZ. At present the APEIs have been designed based on surface ocean characteristics and the topography of the seafloor, estimated from satellite altimetry. At present there has been virtually no sampling of seafloor habitats or species in the APEIs. The NERC cruise aims to change that. The cruise plans to study a representative area of the APEI in great detail at high resolution and over a variety of scales. This will characterise the habitats, biology, physical and chemical conditions

- adding important information about the CCZ in general and making a detailed baseline assessment for this area, which can be compared to other sites and used as a barometer of change in the deep sea associated with mining activities.

The NERC cruise will use a variety of tools for assessment of this >4000m deep area of the CCZ. The autonomous underwater vehicle (AUV) Autosub6000 will carry out wide-area acoustic surveys, collect seabed photographs and make physical measurements of the water column of the APEI. There will also be more detailed HD video surveys of the seafloor using the HyBIS vehicle. Sediment samples, water samples and biological samples will also be collected.

Specifically, the cruise has a number of aims:

1. Obtain multi-resolution AUV bathymetry and backscatter data for resource assessment
2. Assess spatial variation in nodule abundance and size at the landscape scale.
3. Explain patterns in nodule abundance using environmental data (e.g. bathymetric derivatives)
4. Mapping of seabed habitats using acoustic data
5. Characterise the megafaunal, macrofaunal, meiofaunal and microbial assemblages of the APEI (density, diversity, community structure) to compare with other areas in the CCZ
6. Assess spatial pattern in the distribution of megafaunal, macrofaunal, meiofaunal and microbial (patchiness at a range of scales)
7. Assess the environmental controls on megafaunal, macrofaunal, meiofaunal and microbial assemblages (from explanation to prediction)
8. Better understand biodiversity in the CCZ (obtain collections and photographs of as many species as possible for morphological and genetic analysis, will link to other datasets for connectivity studies)
9. Assess rare earth element concentrations in nodules and surrounding sediments
10. Assess geochemistry of sediments and overlying water in nodule area
11. Assess the role of microbes in the formation of Manganese nodules

List of equipment used

Autosub6000 AUV – Deep-water autonomous underwater Vehicle

EM120 - Kongsberg swath bathymetry / sub-bottom profiling system coupled to an OLEX display.

HyBIS – Towed camera system with interchangeable bases (large grab, camera and manipulator modules). Hydraulic Benthic In situ Sampler.

CTD - Conventional conductivity, temperature depth rosette sampler with 24 bottles, ADCP and other sensors

Megacore - A multi-corer for sampling sediment

Boxcore – A 50 x 50cm NMFD-supplied USNEL-type box core for sampling sediment

Gravity core – a gravity corer with a 3m long barrel

SVP - Sound Velocity Profiler

Amphitrap - A free fall baited trap with acoustic releases and buoyancy

Agassiz trawl – Agassiz trawl modified by welding steel bars vertically at 10cm intervals across the mouth of the trawl. This was done to strengthen the trawl for obtaining samples in areas with high nodule densities

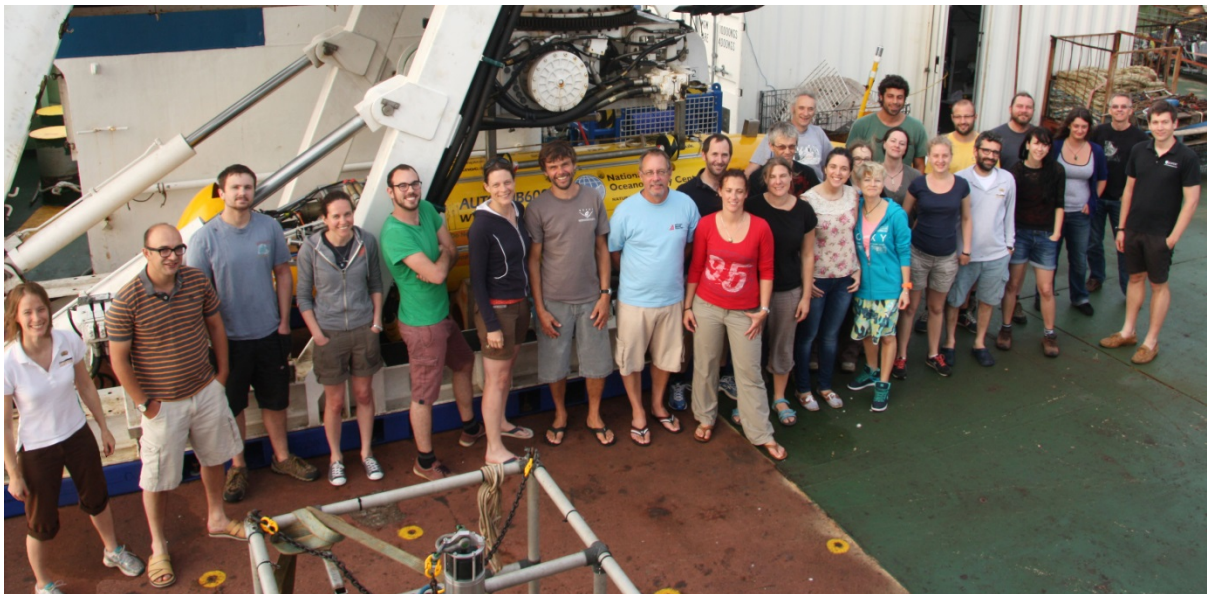

Figure 1: JC120 cruise science and technical team

Narrative

All times and dates are based on the time for the ship

(transit = GMT -5 and GMT -6; Almost all of the science area = GMT -7).

15 April 2015

The science party were given an induction at 10:30.

The ship left the tourist berth in Manzanillo Harbour at 15:00 (GMT -5). We had been delayed in leaving (by 6 hours) as we waited for a member of the scientific team, who had been unavoidably delayed in transit. Her flight arrived in ZLO at 12:10 and she was transferred to the vessel quickly, arriving at around 14:00.

The ship clocks were set back 1 hour (GMT -6) at midnight.

Midnight position: 18°53.2'N 105°46.7'W

Weather: slight seas, fine, air temp. 26.4°C, sea temp. 27.2°C, wind 350° 16kn.

16 April 2015

In transit

We had a boat drill for all people onboard at 10:30.

All science and technical staff attended a science meeting at 14:00

Midnight position: 18°21.7'N 114°45.2'W

Weather: slight seas, partly cloudy & fine, air temp. 24.7°C, sea temp. 27.0°C, wind 010° 6kn.

17 April

In transit

We had a safety meeting at 10:30.

The ship clocks were set back 1 hour (GMT -7) at midnight.

Midnight position: 17°49.4'N 114°45.2'W

Weather: slight seas, partly cloudy & fine, air temp. 24.3°C, sea temp. 25.5°C, wind 020° 12kn.

18 April

In transit

We arrived at the edge of the Mexican EEZ at 17:30. We planned to do a CTD around 5nm away from the edge of the EEZ to get a good SVP for the subsequent swath survey and to provide some eDNA samples throughout the water column. We arrived at the CTD station at 17:45. Unfortunately, there had been a problem with the cooling fan for the inverter that provided the clean power supply and we lost power for around two hours while it was fixed. This prevented several key systems from working and delayed the CTD and SVP deployment. The power was back on at around 19:10. The

CTD was deployed at 19:41 (2:41 UTC). We recovered the CTD successfully at 22:44. Three bottles of water were collected for eDNA analysis at 6 depths (3763, 3713, 3300, 500, 127 and 32 meters depth) and filtered. The Niskin bottles were topped up and acidified to acid clean the bottles prior to trace metal work later on.

At 23:21 we started the EM120 swath and sub-bottom profiler survey towards the NE APEI. We were collecting very good data at 8kn vessel speed. Sea conditions were relatively calm.

We continue to see Gannets following the ship and catching flying fish disturbed by the hull.

Midnight position: 17°24.1'N 118°18.4'W

Weather: slight seas, partly cloudy & fine, air temp. 22.4°C, sea temp. 26.3°C, wind 045° 8kn.

19 April

The swath survey continued to go well and we passed over several seamount features including obvious volcanic cones, some with high backscatter around the rim of the cone. The sub-bottom profiler did not show any obvious sedimentary structures in the flatter areas. We reached the edge of the APEI at 9:45 and turned so we followed a due westerly track line. Our swath width was around 12.5km. The first part of the APEI had seamount complexes with rolling abyssal ridges. As we progressed further west, the terrain started to level out a little and looked more suitable for operations.

The VSAT satellite has been dropping out a lot and most communications have been through the Fleet Broadband system.

Midnight position: 16°55.9'N 121°38.3'W

Weather: slight seas, partly cloudy & fine, air temp. 23.9°C, sea temp. 27.0°C, wind 080° 8kn.

20 April

EM120 swath survey along base of APEI was finished at 16:07 (JC120-003).

Arrived at the edge of the CTD station at 16:20. The CTD was in the water at 17:02 and on deck at 20:15. There was a problem with the CTD bottle firing, which was being controlled by the computer. On the software it was not clear whether they had fired or not. Subsequent CTD bottle firing will be triggered manually.

The acoustic release for the amphipod trap (serial number 332) was also tested on the CTD frame and released successfully.

Hybis was deployed with the grab base at 20:53 and reached the seabed at 22:44. Our first view of the seabed at the APEI showed large numbers, almost complete coverage, of small (1-2cm nodules). There appears to be a gradient in the number and size of nodules along the Hybis transect. The Hybis transect was designed to go from an area of high backscatter (white on our maps) on a slight ridge crest to an area of low backscatter (black on our maps) in a valley between ridges. Our nodule size observations appeared to correspond, with more numerous smaller nodules on the ridge crests and less numerous larger nodules in the valley.

Several organisms were observed on the Hybis transect including stalked sponges, polychaetes, holothurians, anemones and fish.

Midnight position: 16°53.7'N 122°51.1'W

Weather: slight seas, cloudy & fine, air temp. 24.5°C, sea temp. 26.3°C, wind 050° 15kn.

21 April

The Hybis grab was fired at 02:45 and Hybis was recovered, arriving on deck at 05:24. It was not possible to access the core from the top and we emptied the core bucket into a large bathtub. The contents were run through two basket sieves. We recovered hundreds of small nodules and a few larger nodules (up to around 8cm long). Microscopic nodules were also present in the red clay sediments. Several sharks teeth were found in the Hybis grab sample, including an approximately 3cm long shark tooth with serrated edges (preserved by the NHM).

At 06:26 we started an EM120 shipboard swath survey of the work area. We were swathing all day. At 21:00 the weather picked up and we were on a northerly course with the weather head on the bow. This resulted in problems with the swath and backscatter data. We reduced the ship speed to 6kn, which helped the problem a bit. We later found out that the *James Cook* collects better data when the weather is on the beam or the ship is running with the weather. Indeed, the southerly transect was better and we were able to resume the survey speed of 8kn.

Midnight position: 17°25.1'N 122°43.8'W

Weather: slight to moderate seas, low to moderate swell, overcast, air temp. 24.0°C, sea temp. 26.3°C, wind 040° 16kn.

22 April

The swath survey continued through the night.

The AUV was in the water for station JC120-007 at 08:00. The sub was left holding position while the communications were tested. There was limited communication between the sub and the hull-mounted transponder, so the AUV coms fish was launched. Unfortunately, the junction box module within the fish was not functioning. The fish was recovered and the junction box was found to be full of salt water as a result of a crack in the plastic housing (at a bolt hole, caused by overtightening the bolt). As a result of limited communications, the AUV mission was reduced to a test mission, during which the sub dived to 100m and transited between two waypoints. This mission started at 10:10. This test mission was generally successful but the AUV USBL was detecting what it thought was the seabed at 100m depth (not altitude), possibly because of high volumes of biological particulates in the water column at this depth (it corresponded with a fluorescence maximum in the CTD data). The AUV was recovered with no problems.

After the AUV mission the amphipod trap lander was prepared (the traps were baited with yellowfin? Tuna, cut into mackerel-sized pieces and 8 hooks were attached to the frame to try and catch fish). The lander was safely launched at 13:30 (JC120-008).

After the lander release the deck crew switched wires from the deep-tow wire required for Hybis operations to the coring wire (for megacores/boxcores etc).

At the same time as the amphipod trap was being prepared the AUV team and NMF technician had repaired the junction box housing by cutting off the broken section and re-machining the attachments. We spent 15 minutes testing that this new housing was water tight in the fish at 12m depth. It was.

The CTD was deployed at 15:52 (JC120-009). Bottles were fired along a depth transect and the CTD was back on deck at 19:10 (3h20m later).

The megacore was launched at 19:48 (JC120-010). It was prepared for geochemical sampling with 8 tubes, three of which were drilled for profiling purposes. Six of the 8 cores were successful and nodules were obtained in the core tubes. The megacore was back on deck at 23:23 (4h 35m later).

The swath survey was resumed at WP17 and continued all night. There were some problems with poor data on the northerly leg and the speed was reduced.

Midnight position: 16°54.78'N 122°59.83'W

Weather: slight seas, low swell, cloudy and fine, air temp. 24.0°C, sea temp. 26.5°C, wind 030° 17kn.

April 23

The swath survey continued until around 11:45.

Once we had arrived at the AUV test site (in the Deep Plain area), we began preparations for AUV launch. While the AUV was on deck and during tests there was a power issue, which resulted in the camera flash firing and the AUV abort weight being dropped on deck. The AUV camera logger was thought to be responsible. However, a circuit breaker was subsequently found to have failed. It was decided to take this out of the system as multiple other breakers / fuses were on the same circuit. This put the AUV out of action for around 24 hours.

At 17:01 we launched the megacore (JC120-012), which recovered 7 of 8 tubes for biological analysis. The corer was on deck at 20:34 (3h 33 mins).

We then carried out a boxcore sample (JC120-013) at 21:30. The boxcore was on deck at 01:15 (3h 45m) and recovered a fair core. The top water drained through the corner.

The biology team had several sieves and samples were sieved at both 300µm (NHM) and 250µm (others). It should be assumed that all samples need to be sieved to 300µm once they arrive at the laboratory.

As we had all the swath data we were able to plan the subsequent sampling programme. We selected a representative area of ridge and trough, based on broad-scale bathymetric position index (central area 500m, window 10km). These areas were constrained within 100m bathymetry contours. We then selected two areas of flat ground, based on broad scale (500m window) terrain ruggedness index, one area was at an intermediate depth (Flat) and one area was deeper (Deep Plain). Again these were constrained within 100m bathymetry contours. Five sampling locations were selected randomly within each area. The previous samples at the AUV surface test location were all within the Deep Plain area.

Midnight position: 16°54.77'N 122°59.83'W

Weather: slight seas, low swell, cloudy, fine and clear, air temp. 23.7°C, sea temp. 26.3°C, wind 050° 21kn.

24 April

After recovering Boxcore (JC120-013) we steamed up to the ridge area.

At 04:31 we deployed the boxcore (JC120-014) at the ridge 1 area. The boxcore was on deck at 08:07 (3h 36m).

At 10:05 we deployed the boxcore (JC120-015) at the flat 1 area. The boxcore was on deck at 13:32 and was found to be disturbed as the boxcore had bounced twice on the seabed.

As we transited from the northern work area back to the first AUV surface test location we collected swath data (JC120-016). We arrived at the AUV test location at 16:08.

We started the preparations for an AUV mission. Unfortunately, the fish quickly stopped working after deployment. The AUV was still on deck and remained so. When the fish was recovered and taken apart, it became apparent that the junction box pressure case had failed and flooded with salt water again (it was full of water). This contained the only spare electronics. The two sets of junction box electronics had both been flooded now. With no more spares available, the flooded parts were rinsed in milli-Q water, dismantled, dried and then sprayed with WD-40. Fortunately, one of the electronic units started working after this.

As the fish junction box housing was so unreliable, work was started on sourcing a spare housing. The AUV team found a titanium housing that was not being used that had an identical diameter to the original plastic housing. They were able to modify the existing plastic pressure cap (with penetrators / connectors) to fit on the titanium tube.

This work on the AUV took some time so we continued with a coring programme.

We had a coring team meeting at 16:00 to try and capture the lessons learned from the previous core deployments and ensure standards were good and consistent and data were all captured and complete.

At 18:43 we deployed the first gravity core (JC120-017) at the AUV surface test location (deep plain site). This was on deck at 22:15 (3h 32m). The gravity core collected a reasonable sample but the sediment water interface was not visible as the sediment had come out through the top of the core. This meant that the core was not useful for working out the depths from the sediment surface for the chemical measurements. The soft sediments were easy to core and less weight will be put on the corer for the next deployment.

We then began the transit back to the flat area. The EM120 swath was turned on for the transit (JC120-18).

Midnight position: 17°11.3'N 123°01.1'W

Weather: moderate seas, moderate swell, overcast, air temp. 24.3°C, sea temp. 25.9°C, wind 080° 24kn.

25 April

We arrived in the northern area at 00:27.

At 00:47 the megacore was deployed (JC120-019) at the flat 2 site. This was set up for biological operations (no drilled tubes) with 8 tubes. The megacore was on deck at 04:20 (3h 33m) and had taken a good sample.

At 05:08 the megacore was deployed (JC120-020) at the flat 3 site for biological sampling. The megacore was on deck at 08:53 (3h 45m) and had obtained a good sample in 4 cores of 8.

At 09:11 the boxcore was deployed (JC120-0021) at the flat 3 site. An acceptable sample was obtained.

At 13:25 the boxcorer was deployed at (JC120-022) at the flat 2 site. The corer was recovered at 16:47 (3h 22m) and it retrieved an acceptable sample.

After the core the AUV fish was tested at 17:45 for 15 minutes. It was found to be working.

At 18:11 the megacore was deployed (JC120-023) at the flat 1 site for biological analysis. It was back on deck at 21:31 (3h 20m) and it had recovered good samples in all 8 tubes.

At 22:42 the megacore was deployed (JC120-024) at the flat 4 site for biology. The corer was back on deck at 02:05 (3h 23m) after recovering samples in all 8 tubes.

Midnight position: 17°13.20' N 123°02.67'W

Weather: moderate seas, confused moderate swell, overcast, air temp. 24.4°C, sea temp. 25.4°C, wind 050° 22kn.

26 April

At 03:11 the megacore was deployed (JC120-024) at the flat 1 site for geochemical analysis. The megacore was back on deck at 06:40 (3h 29m) after recovering samples in all 8 tubes.

After the megacore was up we steamed to the AUV mission location in the flat area. The AUV was in the water at 08:15 for AUV mission 76 (JC120-026). The AUV was underwater at 08:25. The AUV was programmed to go down to 1000m and wait for a command to proceed. Unfortunately, the acoustic communications with the sub were unsuccessful as a result of an incorrect setting on the AUV surface computer (this was not found out until 14:10 - during M77). As no communication was received in the designated time window, the AUV mission was aborted and the AUV returned to the surface. The AUV arrived at the surface at 11:35.

At 11:55 the AUV team were able to send a new mission plan to the floating AUV via WiFi. This mission M77 (JC120-027) was the same as the previous mission, except the AUV was not required to wait for an acoustic command prior to commencing the rest of the mission. Although acoustic communications couldn't be established, we could have got good data from the mission. Normally after completing the navigation box on the seafloor the AUV is sent a command that tells it an offset from where it thinks it is to where it actually is (determined by acoustic interrogation of the USBL beacon from the ship). If no acoustic communications were available we could still calculate the offset but could not apply it. This would mean that we could establish accurate geographic positions of the AUV by correcting the navigation after the dive, but we could not target specific features on the seafloor during the dive (as there would still be the offset in the navigation).

The AUV commenced its dive as planned, reaching 1000m at 12:35, 2000m at 13:10 and 3000m at 13:45. At 14:10 the AUV team found the problem with the acoustic communications resulted from an incorrect setting on the topside computers and started communications with the AUV.

At 15:22 the AUV surfaced after having dropped its abort weight shortly after reaching the target altitude of 100m above the seabed. The AUV was recovered at 16:20. The fault with the AUV seems to have been a combination of a ground fault and another fault. They had not established a cause for the problem by the end of the day. Subsequent investigations showed that the AUV aborted the dive

as a result of a buoyancy issue. The AUV was not going down fast enough and thought that it was stuck. The ground fault would have caused an aborted dive if the buoyancy issue had not happened.

In the meantime, the megacore was deployed (JC120-028) at 18:04. This core was recovered at 21:34 (3h 30m) having successfully recovered sediment in all 8 tubes.

A boxcore was deployed (JC120-029) at 22:15 with the penetration limiter off at the trough 1 site. The core was recovered at 01:45 (3h 30m) having recovered a good sample. There was still some wash out, but this was reduced compared to other samples.

Midnight position: 17°13.06'N 122°49.38

Weather: slight / moderate seas, confused moderate swell, partly cloudy, air temp. 23.8°C, sea temp. 25.1°C, wind 060° 21kn.

27 April

A swath survey was carried out between the trough site and the deep plain site (JC120-030) starting at 03:00. This covered some areas of noisy data in the previous survey. The new bathymetry data were good. However, owing to the different survey path the backscatter data were not very useful.

We arrived at the deep plain site and deployed the modified Agassiz trawl (modified with bars welded vertically across the opening – every 100mm – to strengthen the frame and reduce the number of nodules that were captured). The trawl was deployed (JC120-031) at 06:26 and a pinger was put on the first part of the trawling wire, after the 500m pennant wire. The trawl was deployed with the ship moving at 0.5kn at 040° heading. The pinger was not working very well, but we estimated that the trawl was on the seabed at 10:04. The trawl was then slowly recovered. The end of the pennant wire was on deck at 13:15 and the trawl itself was on deck at 13:47 (7h 21m). The trawl was unsuccessful, there was no catch and nothing tangled in the mesh. There was mud on the frame and staining the net but the cod end had parted. This was probably caused by the trawl taking one big bag of sediment on its first bite of the seabed.

After the trawl we transited back to the Trough site. The swath was turned on (JC120-032). The transit was started at 14:11.

The gravity corer was deployed (JC120-033) at the trough 1 site at 16:40. The corer was deployed with only half the weights and the sediment still came out of the liner (only by ~25cm). There was a problem with the CLAM system as a result of a faulty USB stick that records the data. This meant that the gravity corer recovery was slower than expected. The gravity corer was back on deck at 20:13 (3h 33m) with a good sample.

At 21:29 we deployed (JC120-034) a megacore for biological analysis at the Trough 2 site. This was reasonably successful, obtaining 5 of 8 tubes of sediment. The core was back on deck at 00:57 (3h 38m).

Midnight position: 17°09.47'N 122°48.78'W

Weather: slight seas, moderate swell, cloudy fine and clear, air temp. 24.2°C, sea temp. 25.1°C, wind 030° 11kn.

28 April

At 02:35 we deployed (JC120-035) the CTD (with SVP) at the Trough 1 site. The CTD obtained samples at several depths (5 x 4230; 2 x 4225; 2 x 4215; 2 x 4185; 2 x 4135; 2 x 3735; 6 x 2800m). The CTD was recovered at 06:03 (3h 28m).

During the transit between Trough 1 and Flat 1 we obtained swath data (JC120-036)

At 08:15 the Agassiz trawl was launched (JC120-037). It was back on deck at 14:19 (6h 4m). The trawl successfully obtained a sample from the seabed, without damage. The sample comprised around 40kg nodules. When we sorted carefully through the sample we obtained several megafaunal organisms (a large prawn and an ophiuroid were the best megafaunal specimens). We also obtained some sharks' teeth, including *Carcharodon megalodon* and *C. carcharias*, and some whale ear bones. *C. megalodon* lived between 2.6 and 15.9 million years ago, so these teeth must have been on the seabed for a considerable time.

After the trawl we transited from the flat 1 site to the north of the trough site. We obtained swath data and a sub-bottom profile across the primary habitat types (JC120-038). This one was done at a low speed to try and get as good sub-bottom profile data as possible.

At 17:03 we deployed the amphipod trap with 10 hooks at the north of the trough site (JC120-039). We used tuna bait, cut into mackerel-sized chunks (within the 4 traps) and smaller pieces of tuna as bait on the hooks. This trap was recovered on the 30th April after a soak time of 39:26 hours. The trap was released from the seabed at 10:15 (30 April) and was on deck at 12:25 (30 April). The trap caught tens of amphipods in the traps but nothing on the hooks.

We did a short swath line and SBP within the trough (JC120-040) on the way to the next station.

The weather was good and the swell low so we launched Hybis at 18:25 with the vertical camera base for JC120-041 at the trough site. The seabed was in view at 20:52 and we started the survey at 20:59. The 6km long zig-zag dive was complete at 06:11 and Hybis was on deck at 08:15. There had been a problem with the winch resulting from lots of small movements and they had to pay out additional cable to fix gaps in the wraps on the drum. This resulted in a short delay.

Midnight position: 17°13.70'N 122°49.2'W

Weather: slight seas, low swell, partly cloudy, air temp. 22.4°C, sea temp. 25.1°C, wind 080° 16kn.

29 April

During the transit between trough and flat area we carried out a swath and SBP profile (JC120-042). The swath line started at 08:57 and ended at 09:50.

At 10:26 we launched Autosub6000 for Mission M78 (JC120-043). The mission started at 10:36 and the vehicle had submerged at 10:39. The vehicle was recovered on 30th April and on deck at 14:50 (total of 28h 11m underwater).

At 16:22 we launched Hybis (JC120-044) at the ridge site.

Midnight position: 17°20.95'N 122°53.0'W

Weather: slight seas, low swell, cloudy and fine, air temp. 23.3°C, sea temp. 24.5°C, wind variable 4kn.

30 April

Hybis was recovered (JC120-044) at 06:23 after a successful dive. The pictures were not as good as the previous dive as we had set the camera to have aperture priority (F8), which meant that the shutter speed was too slow (1/25) and some image blurring resulted.

We carried out a swath and sub-bottom profile between the ridge and flat site (JC120-045). The line was started at 06:37 and completed at 08:29.

We had planned to pick up Autosub at the flat site at 8:30. When we got there we found that the mission was going to take longer than we thought and was due to end at 12:00. As a result we went back to the ridge site to recover the amphipod trap. This transit was completed very quickly.

We recovered the amphipod trap at 12:25 (JC120-039). See above for details. It turned out that the amphipod trap surfaced a few minutes after Autosub surfaced (at the flat location). So after recovering the amphipod trap we went straight to the flat area to recover Autosub. Autosub was recovered successfully (M78) having carried out a swath bathymetry survey at an altitude of 100m of an area of seabed at the flat site of approximately 10km by 2km. In addition, a 10km line was carried out at 50m altitude with the Edgetech low-frequency side-scan sonar running. There were some problems with the bathymetry data, which meant that they were more difficult to process.

We did a Hybis dive (JC120-046) at the flat area. Hybis was off deck at 15:49 and started the transect at 18:10. This was a successful dive with lots of good photographs obtained.

Midnight position: 17°15.1'N 123°04.1'W

Weather: slight seas, low swell, cloudy and fine, air temp. 24.0°C, sea temp. 24.3°C, wind 060° 10kn.

1 May

The Hybis transect was stopped at 03:27 as there was a problem with the winch. Hybis was on deck at 05:50.

There was some delay while Autosub was prepared. We were expecting an increase in swell height, so it was important to get the AUV in the water as soon as possible. As a result, we waited until Autosub was ready.

The AUV was launched at 09:32 (JC120-047; Autosub Mission 79) and started diving at 09:34. It had completed the navigation box at 15:12. The AUV was carrying out a photography mission at the flat site, within the area surveyed in the last mission. The AUV was recovered to deck at 15:40 on the 2nd May (total of 30h 6m underwater).

At 16:42 the megacore (JC120-048) was deployed at the Ridge 1 site for geochemistry. The core was back on deck at 20:09 having collected all eight tubes of sediment.

At 20:42 the megacore was deployed (JC120-049) at the same site (Ridge 1) for biological analysis. The core was back on deck at 00:10 having collected all eight tubes of sediment.

Midnight position: 17°21.56'N 122°54.18'W

Weather: slight seas, long low swell, cloudy and fine, air temp. 24.0°C, sea temp. 24.7°C, wind 040° 14kn.

2 May

At 01:53 the boxcore was deployed (JC120-050) at the Ridge 2 site. It was recovered at 05:42 having obtained a good sample.

During the transit between the ridge and the flat areas we obtained swath and sub-bottom profiler data (JC120-051). The line was started at 06:35 and finished at 07:36.

We tried, unsuccessfully, to track the AUV. Having not found it we proceeded with the next station, waiting for the AUV to finish its mission.

At 10:58 the CTD was deployed (JC120-052) at the Flat 1 site. It did a profile and collected water at (5 x 4147m; 2 x 4143; 2 x 4122; 2 x 4087; 2 x 4047; 2 x 3798 and 2 x 2800m depth). The CTD was on deck at 14:04.

We then proceeded to the AUV mission endpoint and picked up Autosub (JC120-047; Autosub Mission 79). The AUV was recovered to deck at 15:40. The AUV had successfully completed its mission, as planned. Owing to buoyancy issues, the AUV speed was reduced to 1.2m/s, explaining the difference in expected and actual AUV mission length.

At 17:16 we deployed (JC120-053) the CTD at the Ridge 1 site. The CTD was back on deck at 20:30.

At 20:57 we deployed (JC120-054) the Gravity core at the Ridge 1 site. The Gravity core was back on deck at 23:52. It had obtained a good sample with very little, if any, over penetration.

Midnight position: 17°21.51'N 122°54.17'W

Weather: slight seas, long low swell, overcast and fine, air temp. 24.5°C, sea temp. 24.7°C, wind 040° 10kn.

3 May

At 00:53 we deployed (JC120-055) the boxcorer at the Ridge 3 site. The boxcore was on deck at 05:18.

At 05:38 we deployed (JC120-056) the boxcorer at the Ridge 4 site. The corer obtained a good sample. This site was unusual in having stiffer dry clay. The boxcore was on deck at 09:03.

At 11:03 we deployed (JC120-057; Autosub Mission 80) the AUV at the Ridge site. We had planned a swath bathymetry (at 100m altitude) survey that collected data at the Ridge site before transiting to the trough site to collect a few swath lines there. The AUV began its mission at 11:10 and had completed the navigation box at 14:59, leaving the ship free to carry on the coring programme. The AUV surfaced on the 4th May at 12:42 (total of 25h 32m).

At 15:48 we deployed (JC120-058) the megacore at the ridge 2 site. The corer was back on deck at 19:12 (3h 24m) having obtained 7/8 cores.

At 20:22 we deployed (JC120-059) the megacore at the ridge 3 site. The corer was back on deck at 23:35 (3h 13m) having obtained 7/8 cores (two cores were lost during processing).

Midnight position: 17°22.02'N 122°53.98'W

Weather: slight seas, low swell, cloudy and fine, air temp. 24.9°C, sea temp. 24.6°C, wind 070° 15kn.

4 May

At 01:45 we deployed (JC120-060) the boxcore at the trough 2 site. The boxcore was back on deck at 09:34.

At 06:00 we deployed (JC120-061) the boxcore at the trough 3 site. The core was recovered at 09:34 (3h 34m). In this core I went through the deeper layers of mud and found a layer of larger nodules at around 15cm below the surface of the sediment. This may be the result of a sediment slip event covering up an old nodule field.

At 10:27 we deployed (JC20-062) the megacore at trough 3. All 8 tubes were full of sediment. The megacore was back on deck at 14:02 (3h 34m).

At 12:42 the AUV was at the surface after mission 80 (JC120-057). We recovered the vehicle at 16:07.

At 17:02 we deployed (JC120-063) the megacore at trough 1. The corer was back on deck at 20:34 (3h 32m). This was a deployment for geochemistry with three drilled cores. All 8 tubes were recovered full of sediment.

At 21:18 we deployed (JC120-064) the megacore at trough 4. The corer was back on deck at 00:42 (3h 24m). The corer recovered 4 of 8 tubes of sediment.

Midnight position: 17°13.88'N 122°48.90'W

Weather: slight seas, low swell, overcast, air temp. 24.6°C, sea temp. 24.7°C, wind 050° 20kn.

5 May

At 01:50 we deployed (JC120-065) the megacore at ridge 4. Six tubes of 8 were full of sediment on recovery. The corer was back on deck at 05:08.

At 05:58 we deployed (JC120-066) the megacore at ridge 5. Four of 8 tubes were full of sediment on recovery. The megacore was back on deck at 09:03.

At 10:15 we deployed (JC120-067) the megacore at trough 5. The megacore was back on deck at 13:45.

We went to the AUV dive start location and deployed the AUV (JC120-068) at 14:57. Unfortunately, the vehicle didn't dive. It appeared that a fuse had blown and the vehicle had dropped its dive weight on the surface. There was also a ground fault recorded. The vehicle was recovered and back on deck at 15:57. Subsequent investigations suggested that the power harness was faulty and was replaced.

At 16:45 a boxcore was deployed (JC120-069) at the trough 4 site. The core was back on deck at 20:32. After the biology samples (0-2 and 3-5cm) were taken, the core >5cm was searched for deeper nodules by sieving through the 10mm mesh bucket sieve. No nodules were found.

At 21:47 a boxcore was deployed (JC120-070) at the trough 5 site. The core was back on deck at 01:18. Sharks' teeth were found on the core surface, including a *C. megalodon* tooth.

Midnight position: 17°17.78'N 122°50.13'W

Weather: slight seas, low swell, fine, air temp. 23.4°C, sea temp. 24.7°C, wind 040° 16kn.

6 May

A swath and SBP profile was carried out (JC120-071) as we transited between the trough and flat site. The survey was began at 01:59 and ended at 03:10.

At 03:30 a boxcore was deployed (JC120-072) at the flat 4 site. The corer was on deck at 07:20 (3h 50m).

At 08:00 a boxcore was deployed (JC120-073) at the flat 5 site. The corer was on deck at 11:32 (3h 32m).

At 13:05 a gravity core was deployed (JC120-074) at the flat 1 site.

At 17:06 a megacore was deployed (JC120-075) at the flat 5 site. The core included one drilled tube for oxygen profiling. The corer was on deck at 20:38 (3h 32m). The corer recovered 7 of 8 tubes containing sediment.

At 21:16 a megacore was deployed (JC120-076) at the flat 3 site. This was a repeat of a previous core (JC120-020) that had not returned much sediment. The corer was back on deck at 00:41 (3h 25m). The core included one drilled tube for oxygen profiling. The corer recovered sediment in 7/8 samples.

Midnight position: 17°15.03'N 123°01.75'W

Weather: slight seas, low swell, partly cloudy and fine, air temp. 24.3°C, sea temp. 24.4°C, wind 060° 19kn.

7 May

At 02:37 the boxcore was deployed (JC120-077) at the ridge 5 site. The corer was on deck at 06:00 (3h 23m).

At 08:18 the AUV was launched (JC120-078; Autosub mission 82) at the trough site. The AUV was programmed to obtain some bathymetry data at the trough site and then transit over to the ridge site, where it will carry out a photographic mission. We followed the vehicle with the ship's USBL tracking system until the mission started at 12:18 (4h).

At 14:00 Hybis was launched (JC120-079) for a photographic mission transiting between the trough site and the flat site. This was designed to image some of the steeper wall features that we could not see with the AUV. We obtained images of the scarp features, which had some exposed basalt. There was a lot of variation in nodule density.

Midnight position: 17°17.20'N 122°50.10'W

Weather: slight seas, low swell, overcast, air temp. 24.0°C, sea temp. 24.7°C, wind 060° 16kn.

8 May

After the Hybis run we transited to the deep plain site (JC120-080) collecting swath and sub-bottom profiler data. We started the line at 16:27 and ended at 18:37.

At 18:58 we deployed (JC120-081) the gravity core at the deep plain 1 site. The gravity core was recovered at 22:25 (3h 33m). It obtained a good core with no over penetration. This core was a repeat of JC120-017.

At 23:02 we deployed (JC120-082) the boxcorer at the deep plain 2 site. The boxcore was back on deck at 02:55 (3h 53m).

Midnight position: 16°54.17'N 123°00.96'W

Weather: slight seas, low swell, overcast, air temp. 25.0°C, sea temp. 25.5°C, wind 060° 25kn.

9 May

At 03:42 we deployed (JC120-083) the boxcorer at the deep plain 3 site.

At 08:05 we deployed (JC120-084) the megacore at the deep plain 3 site. The core recovered all 8 tubes of sediment.

We transited between the deep plain and trough site and collected swath and sub-bottom profiles (JC120-085). The line started at 9:56 and ended at 12:56.

We deployed Autosub at the trough site (JC120-086) for a swath, side-scan and photographic mission. This mission had been named M82 in error (we had already completed M82) The AUV was launched at 15:03. The mission was started at 15:09 and the vehicle dived at 15:11. At 18:15, during the navigation box, the sub was observed to be circling instead of continuing its mission, probably as a result of a jammed rudder. At 18:34 we sent the command for the sub to surface. To save time on ascent we sent an abort command at 18:50. The AUV was back on deck at 20:08.

As a result of limited time availability we decided to reduce the length of the AUV mission and so sent a new mission plan to the vehicle. This new mission included some side-scan at 50m at the ridge site and then the trough site and a photographic run at the trough site. The vehicle was launched for mission 83 (JC120-087) at 23:36. The mission was started at 23:43.

Midnight position: 17°16.84'N 122°52.5'W

Weather: slight seas, low swell, overcast, air temp. 24.0°C, sea temp. 24.7°C, wind 030° 19kn.

10 May

The AUV started the navigation box at 02:17. The navigation box was completed at 03:16. We were monitoring the AUV during descent and navigation box, as planned. A new offset command was transmitted at 03:21 and the AUV started the first mission leg at 03:28. The AUV was on the surface at 23:02 but it we did not return until the 11th May. The vehicle was sighted at 06:48 on the 11th May. This mission was successful.

At 04:48 we started the transit over to the volcanic cone seamount site (JC120-088) we were recording swath and SBP data over this north to south line. The line finished at 08:09.

At 08:28 we deployed (JC120-089) Hybis at the volcanic cone site. We planned a mission that went from the plain at the edge of the summit down into the caldera and up the other side again. We found extensive areas of exposed basalt and a sedimented area within the caldera. There were steep, near vertical, basalt walls at the edge of the caldera with little life. The photographic transect was started at 10:16 and ended at 15:12. Hybis was recovered after this at 16:48.

At 18:23 we deployed (JC120-090) the megacore (with 3 drilled tubes) at the sedimented area we had noted on the Hybis run in the centre of the caldera. The megacore was recovered at 21:29 having collected 6 of 8 tubes of sediment. It had paler and coarser sediment than previously observed.

During the transit between the volcano site to the deep plain we collected (JC120-091) swath and SBP data. This line started at 21:53 and ended at 23:36.

Midnight position: 16°54.15'N 123°00.97'W

Weather: slight seas, low swell, overcast, air temp. 24.9°C, sea temp. 25.7°C, wind 060° 18kn.

11 May

At 00:02 we deployed (JC120-092) the megacore (deep plain site). Recovered at 03:48 (3h 46m).

During the transit between the deep plain site and the trough we collected (JC120-093) swath and sub-bottom profile data. The line started at 04:20 and ended at 06:47.

We collected the AUV after mission 82 (JC120-087). See earlier section for details.

We then transited over to the volcano site (JC120-094). The transit started at 07:50 and ended at 09:58.

At 10:22 we deployed (JC120-095) the CTD in the caldera of the volcano.

During the transit from the volcano site to the edge of the APEI we collected swath and SBP data (JC120-096). We started this survey at 13:41 and reached the edge of the APEI at 17:48.

We continued collecting Swath and SBP data (JC120-097) as we progressed to the UK1 area. This survey continued from the last survey and started at 17:51.

Midnight position: 16°08.6'N 122°00.4'W

Weather: slight seas, low swell, overcast, air temp. 24.9°C, sea temp. 25.1°C, wind 040° 17kn.

12 May

In transit continuing swath and SBP survey (JC120-097)

Midnight position: 14°04.4'N 117°34.1'W

Weather: slight seas, low swell, partly cloudy and fine, air temp. 26.4°C, sea temp. 27.2°C, wind 050° 15kn.

13 May

The swath and SBP survey (JC120-097) continued until 03:51.

We picked a small study area with no obvious seamounts (based on GEBCO bathymetry) in the UK1 mining area. We wanted an area to compare to the APEI. The area was at a similar depth to the APEI and around 750km away. We thought the UK1 area we selected would have a high coverage of nodules.

When we arrived at the western edge of the study site in the UK1 area at 04:13 we deployed (JC120-098) the CTD and SVP to get a good sound velocity profile for the swath data. This was back on deck at 07:13 having collected 8 water samples (2 at 4207m, 2 at 4162m, 2 at 4112m and 2 at 3712m).

We then carried out a swath survey from west to east (JC120-099) to try and find an optimal site for the AUV launch. This survey was started at 08:06 and finished at 14:38. The area was comprised of predominantly rolling hills and valleys, with some steeper transitions (scarps) between features. We designed an AUV survey on one of the flat areas on top of a ridge.

The AUV was launched (JC120-100; Mission 84) at 15:10 and dived to 100m altitude. The AUV started the navigation box at 18:00. The AUV team sent a navigation update to the vehicle and at a similar time lost communications with the sub. We could see that the vehicle was rising towards the surface at around 0.5 m/s at this point. The AUV reached the surface at 22:01.

At 23:11 we deployed (JC120-101) the gravity core. It was recovered to deck at 02:13 (3h 02m) having obtained a good core.

Midnight position: 13°27.8'N 116°36.5'W

Weather: slight seas, low swell, overcast and rain, air temp. 26.0°C, sea temp. 26.8°C, wind 120° 9kn.

The UK1 area is just within the intertropical convergence zone, known to have heavy rain showers.

14 May

At 02:49 we deployed a megacore (JC120-102). During the lowering of the core to the seabed we were reviewing a video of the deployment and noticed that the core had not been armed. As a result, the core was retrieved before reaching the seabed. It reached the surface at 05:10.

We waited on station for the AUV team to get the AUV ready for re-deployment. We did not want to do any additional work because we needed to deploy the AUV as soon as possible. Later deployment would have meant that we would not recover the vehicle before the cut-off time for leaving this site.

The AUV was ready at 07:46 and was launched. There was a communication problem with the vehicle and WiFi communications were lost. We were manoeuvring the vessel to get close enough to throw the grappling hooks over the AUV and WiFi connections were resumed. As a result we were able to set the AUV going on its mission. The AUV dived at 09:47 for mission 85 (JC120-103). The AUV started the navigation box at 12:15. The AUV was recovered at 14:40 on the 15th May. Unfortunately, little data were obtained. Only the edgetech side-scan sonar data were collected.

At 14:20 we deployed (JC120-104) an Agassiz trawl at the UK1 site. This was on the seabed for around an hour at 0.5kn. The trawl was recovered to deck. We collected some nodules and fauna. The nodules were considerably larger than in the APEI area.

At 21:28 we deployed (JC120-105) the megacore to take some geochemical samples at the UK1 area. The corer was on deck at 00:40 having obtained 6 of 8 samples.

Midnight position: 13°27.81'N 116°50.0'W

Weather: slight seas, low swell, heavy rain, air temp. 26.1°C, sea temp. 26.8°C, wind 040° 9kn.

15 May

At 01:23 (GMT-7) we deployed (JC120-106) the megacore to take some biological samples. The corer was on deck at 04:05 (GMT-6) having obtained sediment in 4 of 8 cores.

The clocks went forward one hour (to GMT-6) at 02:00

At 06:26 we deployed (JC120-107) the boxcore.

At 10:41 we started a swath survey around the UK1 area (JC120-108), while we were waiting for Autosub to come up. This survey finished at the AUV recovery area at 13:50.

We recovered the AUV and set off towards the site at a similar depth to the APEI, but much closer to the Mexican EEZ (we were still in international waters). During this transit we collected swath and sub-bottom profiler data (JC120-109). This survey started at 16:23.

Midnight position: 13°54.5'N 115°40.2'W

Weather: slight seas, low swell, cloudy fine and clear, air temp. 27.6°C, sea temp. 27.6°C, wind 060° 16kn.

16 May

We arrived at the HyBIS location (14° 57.001' N 113° 41.2' W) and deployed (JC120-110) HyBIS at 10:32. At 15:00 we recovered HyBIS and it was on deck at around 16:40.

We then set off on our way back to Manzanillo. Our last scientific sample (JC120-111) was a swath transect from the Hybis location to the edge of the Mexican EEZ. This run was started at 16:57 and we turned off the system just before we got into the Mexican EEZ at 01:45 on 17th May.

Midnight position: 13°18.5'N 112°51.3'W

Weather: slight seas, low swell, fine and clear, air temp. 26.6°C, sea temp. 27.0°C, wind 060° 16kn.

17 May

Swath survey continued until 01:45. After this we transited directly towards Manzanillo.

Clean power was shut down in the lab for a few hours.

Midnight position: 16°58.5'N 108°55.8'W

Weather: slight seas, low swell, partly cloudy, fine and clear, air temp. 26.0°C, sea temp. 27.1°C, wind 350° 5kn.

18 May

The clocks went forward one hour (GMT-5) at 02:00.

Transit towards Manzanillo

19 May

Arrive at Manzanillo 07:00.

End of cruise.

Geophysical data processing

Veerle Huvenne and Katleen Robert (NERC NOC)

Eight types of acoustic data were processed, cleaned and mosaiced/plotted during JC120:

1. RRS *James Cook* EM120 Multibeam bathymetry (191 beams)
2. RRS *James Cook* EM120 Multibeam backscatter (12kHz)
3. RRS *James Cook* SBP120 sub-bottom profiler data
4. Autosub EM2040 Multibeam Bathymetry (256 beams)
5. Autosub EM2040 Multibeam Backscatter (200kHz)
6. Autosub Edgetech Low frequency Sidescan (120kHz)
7. Autosub Edgetech High frequency Sidescan (410kHz)
8. Autosub Edgetech CHIRP profiles

The software packages used were CARIS HIPS & SIPS v.8.0 for shipboard bathymetry, Fledermaus FMGT for shipboard backscatter, CARAIBES for Autosub bathymetry, PRISM v5.0 for Autosub backscatter and sidescan sonar, and a combination of Matlab, Linux code and SeismicUnix for the CHIRP and SBP profiles.

Not all systems were run at the same time, Table 1 gives an overview of the datasets that were produced, the resolutions of the final processing results and some additional information.

Shipboard EM120 Multibeam Bathymetry (191 beams)

Multibeam data were collected with the shipboard Simrad EM120 system along all long transits, during a number of dedicated multibeam surveys, and in general along most passages between sample stations if they took more than ~1hour (although in a few cases this was not carried out). For dedicated surveys, a speed of 8kn was used, occasionally reduced to 6kn when data quality was too poor. All other transits were carried out at full speed (~10kn). The system was kept in 'DEEP' mode (expected depths between 800 and 5000m), and swath width was fixed at 60deg on either side, with equidistal spacing. A sound velocity profile was taken at the start of the cruise, as soon as multibeam operations started (i.e. just outside the Mexican EEZ), and at the start of every major multibeam survey. Additional sound velocity profiles were recorded during every CTD station, which will be available for post-processing if deemed necessary. However, during the cruise, each area was processed with one SVP only.

Data processing was carried out in CARIS Hips & Sips v8.0. For each area, a new project was created, using the UTM zone that was most appropriate (see Table 1). The vessel file used was James_Cook_EM120_TLB.hvf, and had the following offsets:

Time Corr: 0.00

X (m): 1.832

Y (m): 19.199

Z (m): 6.944

Pitch (deg): 3.00 (later corrected to 0)

Roll (deg): 0.00

Yaw (deg): 0.00

The data were imported as .all (Generic Simrad data), and were checked for navigation and attitude (generally OK). The 'zerotide' was applied, the data were merged and a BASE surface with 100m grid size was calculated. An initial calibration exercise did not indicate any errors, but later on in the cruise (after the first main survey of the APEI area was completed and additional data came in through short transit lines), it was observed that a pitch error remained. It turned out that the pitch error of 3 degrees wasn't right, and it was taken out. Data cleaning was carried out on the individual

Table 1. Overview of shipboard and Autosub-based bathymetry, backscatter, sidescan sonar and sub-bottom surveys and pixel resolutions

| Area | EM12 0 bathy | EM12 0 backsc | SBP12 0 | EM204 0 bathy | EM204 0 backsc | EdgeTech LowRes | EdgeTech HighRes | Chirp (pulse length) | UTM zone | Mercator standard parallel | SVP | EM120 lines |
|------------------------------------|--------------------|---------------------|--------------|------------------|----------------------|--------------------|---------------------|----------------------------|-------------|----------------------------------|-------------------------------------|----------------|
| Transit 1 (Mexico EEZ - APEI1) | 100m | 20m | Y(poor) | - | - | - | - | - | 11 | 17 | 19042015_SV_CTD_1_thinned_done.asvp | 0-20 |
| APEI1 | 100m | 25m | Y(some poor) | - | - | - | - | - | 10 | 17 | 19042015_SV_CTD_1_thinned_done.asvp | 21-237 |
| M78 | - | - | - | 5m | 2.5m | 50cm | - | 16ms | 10 | 17 | 1525.vel | |
| M79 - 100m alt | - | - | - | 5m | 2.5m | - | - | - | 10 | 17 | 1525.vel | |
| M79 - 50m alt | - | - | - | 5m | 2.5m | 50cm | - | 16ms | | 17 | 1525.vel | |
| M79 - 40m alt | - | - | - | 5m | 2.5m | 50cm | - | 16ms | | 17 | 1525.vel | |
| M79 - 15m alt | - | - | - | - | - | - | 15cm | 16ms | | 17 | | |
| M79 - 3m alt | - | - | - | - | - | - | 10cm | 16ms | | 17 | | |
| M80 | - | - | - | 5m | 2.5m | - | - | - | 10 | 17 | 1525.vel | |
| M81 - 100m alt | - | - | - | 5m | 2.5m | 50cm | - | 5ms | 10 | 17 | 1525.vel | |
| M81 - 15m alt | - | - | - | - | - | - | 20cm | 5ms | | 17 | | |
| M81 - 3m alt | - | - | - | - | - | - | 10cm | 5ms | | 17 | | |
| M83 - 50m alt | - | - | - | 2m | 1.0m | 50cm | - | 16ms | | 17 | 1525.vel | |
| M83 - 3m alt | - | - | - | - | - | - | 15cm | 16ms | | 17 | | |
| Transit 2 (APEI1 - UKclaim) | 150m | 25m | Y(poor) | - | - | - | - | - | 11 | | 19042015_SV_CTD_1_thinned_done.asvp | 236-305 |
| UKclaim | 100m | 25m | Y | - | - | - | - | - | 11 | | JC120_CTD_8_thinned_done.asvp | 306-330 |
| M84 - 100m alt | - | - | - | 3m | 2m | - | - | - | 11 | 13.5 | 1525.vel | |
| M85 - 100m alt | - | - | - | 3m | 2m | 50cm | - | 5ms | 11 | | 1525.vel | |
| M85 - 50m alt | - | - | - | - | - | 50cm | - | 5ms | 11 | 13.5 | | |
| M85 - 3m alt | - | - | - | - | - | - | 15cm | 5ms | 11 | 13.5 | | |
| Transit 3 (UKclaim - pot. APEI) | 100m | 25m | Y | - | - | - | - | - | 11 | | JC120_CTD_8_thinned_done.asvp | 331-364 |
| Transit 4 (pot. APEI - Mexico EEZ) | 100m | 25m | Y | - | - | - | - | - | 12 | | JC120_CTD_8_thinned_done.asvp | 365-382 |

lines using the Swath Editor, and was fine-tuned with the Subset Editor. Eventually the grids were interpolated (5x5) to fill individual gaps, and exported as ASCII .txt files with lat, long and depth. They were converted into negative depths, and turned into .grd grid files in Surfer (using inverse distance to power 2, with search radius 2 x pixel size), and imported into the cruise ArcGIS (needs setting of the Spatial Reference).

Shipboard EM120 Multibeam Backscatter (12kHz)

Together with the EM120 bathymetry, backscatter data were collected. They were processed in Fledermaus Geocoder Toolbox ('FMGT') v7.4.2b, using default processing for all steps. A project was created for each area, choosing the appropriate UTM zone. The source files were imported, using the default options for the coordinate system. From there, we let the software identify the suggested pixel size, based on the dataset content. An appropriate pixel size close to this value was then chosen, and the data were run through the default set of processing steps ('Mosaic' command). They were exported as GeoTiff and imported straightaway into ArcGIS.

Some of the survey lines in the APEI were of fairly poor quality, even after slowing down to 6kn and with reasonable weather conditions (however sailing into the swell). The FMGT software does not offer many options to interpolate or correct for dropout lines, hence the resulting mosaic was imported into ERDAS for smoothing and filtering. With some trial & error the 'Landsat Destripe' function, followed by a Low Pass filter (11x11 pixels convolution) was found to best improve the mosaic for overall viewing. It did however introduce a fair amount of smoothing, hence for detailed work the original mosaic was best.

Processing in PRISM was also attempted, which resulted in a better solution for the drop-out lines, but again produces a very much smoothed end-result. Processing steps were the following:

- Conversion of .all files to their 'Processed' components in the Kongsberg Neptune 'Replay' programme in the Windows XP emulator.
- Setting up of typical PRISM file structure in the Linux (RedHat) emulator (parent directory with cruise name (JC120), including cdf, nav and necessary mapn folders)
- Conversion to PRISM format in the cdf directory: *em12cdlinux*
- *do_create_index* to create index file in cdf directory, copy to parent directory
- *do_make_nav* in the cdf directory (no-header option), copy to nav folder
- creating map directories with *maptile* in cdf directory or *mapcreate* in each map folder. In this case, a map was created manually to make sure the entire APEI core area was captured in one map, with the long run-in into another one. A Mercator projection with standard parallel (latitude of true scale) of 17N was chosen as it proved less troublesome in PRISM than the UTM projection.
- Copying of commands.cfg file from the library of available commands in the PRISM/dat folder. It contains the following commands:

```
mrgnav -i %1 -o %0 -n navfile.nav -l 0,0
```

```
avg_heading -i %1 -o %0 -l 5
```

```
filter -i %1 -o %0 -b 1,21 -z -v 130,255
```

```
filter -i %1 -o %0 -b 1,301 -h -v 130,255
```

```
filter -i %2 -o %0 -b 31,301 -L -v 130,255
```

wtkombo -i %2 , %1 -o %0 -c 1,1 -a -128

restorehdr -i %1 -h %5

resol -i %2 -o %0 -r res

shade -i %1 -o %0 -t 1,254

- Actual PRISM processing: *prism5* command in the parent directory (or running *prismrange* in the map directories),
- The resulting .lan files were imported directly into ArcGIS (again after identifying the Spatial Reference first).

During the sampling phase of the APEI1 area, we had the opportunity to re-map some sections of questionable bathymetry/backscatter data, and those were processed separately in FMGT, to later on be integrated into the final backscatter mosaic.

Shipboard SBP120 sub-bottom profiler (2.5-6.5 kHz)

Each time EM120 data were recorded, the SBP120 was switched on and data were recorded there as well. However, as none of the scientific party, nor the IT technician had particular expertise in seismics, it took several days before the optimal settings were achieved.

Initial settings included (for full settings, see configuration files in cruise backup):

- External trigger (EM120)
- Linear chirp pulse, ranging from 2500 to 6500 Hz
- Minimised pulse shape (13%), 30ms
- Source power starting at -10, decreased to -30 at some point because there seemed to be too much energy in the water column. Later on this turned out to be the effect of too much gain.
- Beam width Tx: Normal, Rx: Wide 10, Number of Beams: 1
- Calculating delay from depth (EM120)
- Processing included Filters, AGC, Gain and TVG

From 24 April onwards, the source sweep was changed to a Hyperbolic pulse, still ranging from 2500 to 6500 Hz, Beam width Rx was changed to Normal, but 5 beams (with 3deg spacing) were used. Processing was changed to Gain Correction, Filters, AGC and Gain (no TVG any more).

Data were stored in segy format. The first few days, only 'processed' data were stored (i.e. convoluted with the source sweep). From 24 April onwards, also 'raw' data (but still in segy format) were recorded. Raw files were named by time-stamp, processed files were named after the equivalent EM120 line number at the start of recording of each section.

In order to visualise the profiles, a quick command in SeisUnix was used (under Linux, RedHat), reading in the 'processed' segy files and printing a PostScript result :

```
segypread tape=inputfile.seg endian=0 / segyclean / sushift tmin=5 tmax=6 / supsimage perc=98 > outputfile.ps
```

An example profile created through this process is shown in Figure 2. In addition, screen shots were taken from the SBP acquisition computer whenever a feature of interest was observed on the real-time profile.

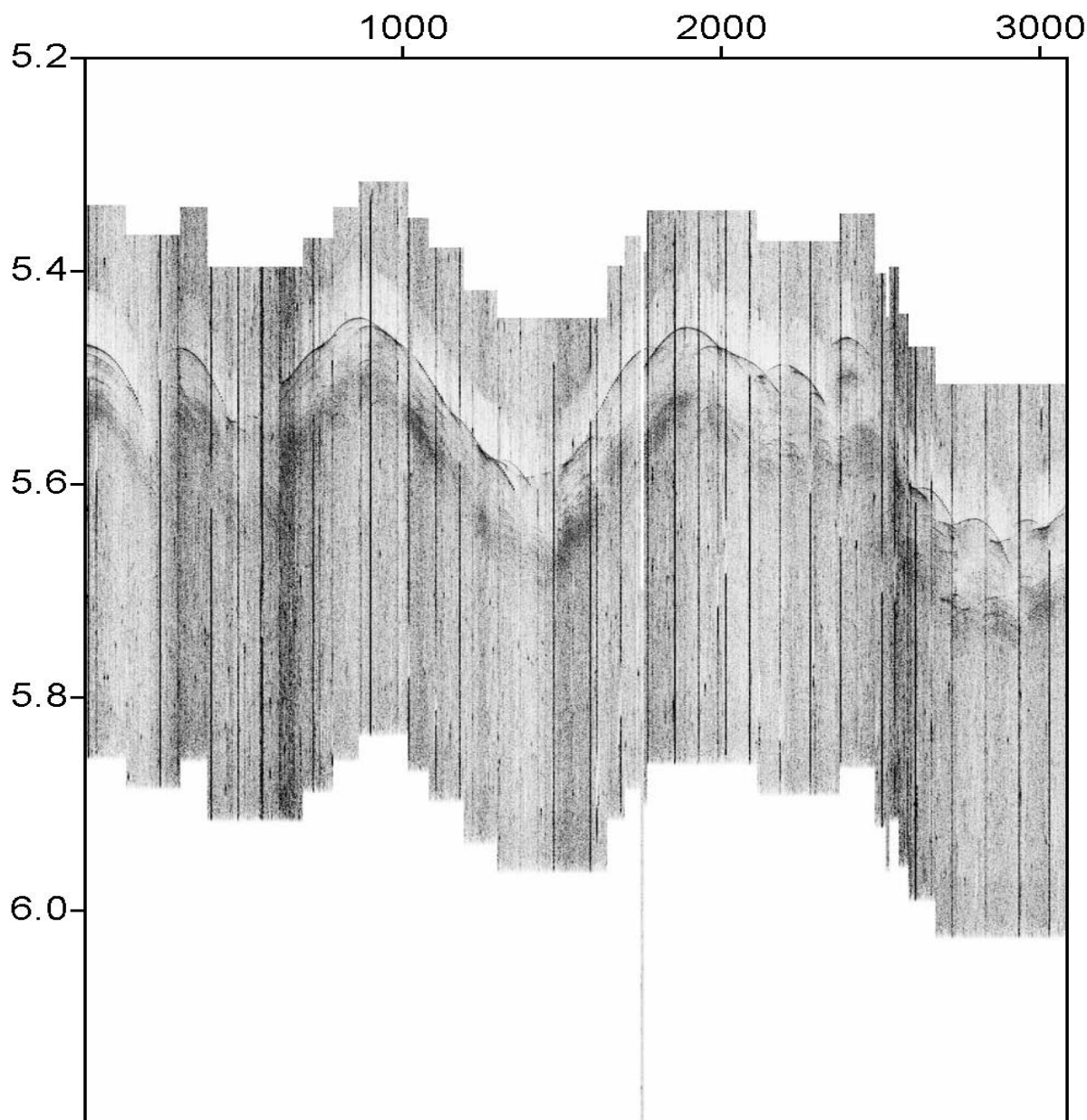

Figure 2. Example shipboard sub-bottom profile from line 323 (Transit 3) collected at ~4110m depth, hyperbolic pulse (2500 to 6500 Hz). X-axis: trace number, Y-axis: two way travel time in seconds (TWT).

Autosub EM2000 Multibeam Bathymetry (256 beams)

JC120 was the first expedition during which the new EM2040 system was used on Autosub6000. The system has three possible working frequencies: 200, 300 and 400kHz. All dedicated bathymetric surveys were run at 200kHz, with a nominal altitude of 100m, but a number of additional datasets were collected for (1) multifrequency backscatter analysis or (2) simultaneous data collection during dedicated low frequency sidescan sonar surveys. Those were carried out at altitudes of 40 or 50m above the seabed. For an overview of surveys, frequencies, altitudes above the seabed and resulting pixel size, please refer to Table 1. The processing flow described below is mainly reflecting the steps and settings for the 200kHz case, although the processing of the other frequencies ran along the same lines.

There had been delays with the integration of the system on the AUV, which meant that no preliminary data was available for testing until the day before we sailed, and even then this was only a short 10 min test in the docks of Manzanillo. The initial plan was to process the EM2040 data with CARIS, much in the same way as the EM120 shipboard data. However, CARIS did not manage to import the .all files. Assistance from Tim Le Bas onshore helped us finding a time-stamp error in the first datagram, but even then, CARIS could not open the .all files. The old Kongsberg Replay software, however, was able to deal with the files and the resulting .depth file could be read by CARIS.

When the first real Autosub mission data came in (M78), however, this processing strategy only worked for the first file - the subsequent ones missing essential header information. To solve the problem, all .all files were concatenated into one large multibeam data file and processed this way. However, once imported into CARIS, it became clear that other problems were persisting. Unrealistic seafloor depths and ping ranges (up to 500000m) were displayed, and the data seemed inaccessible.

An alternative method was sought, and found in the use of the CARAIBES software, written at IFREMER. Although the initial Manzanillo test dataset could not be read into the system, the adapted format (with corrected timestamp in the first datagram) could be imported. Hence, from that point onwards, the EM2040 data processing took place in CARAIBES.

The processing flow included following steps:

- *Tm2040*: importation of .all files, creation of .mbg (bathymetry) and .nvi (navigation) file for each. The function also allows to extract the sound velocity file used for the data recording (.vel). Offsets between the EM2040 sounder (Rx) and Navigation reference (Phins) had to be imported, and were interpreted as the offsets when going from navigation to EM2040: 2.202m ahead, 0.00m across, -0.08m below.

- *Ananav*: quick check on the navigation

- *FusMbg*: concatenation of .mbg files into sections corresponding to the different lines/parts of each survey.

- *Coratt*: application of heading correction. Very early on, it became clear that the EM2040 system is mounted back to front in Autosub6000. By adding a heading offset of -180deg this was corrected ('bias' option, constant value).

- *EdiMbg*: function to display and extract individual parameters, used to extract roll data from each .mbg into .txt files. Diagnostics on the first EM2040 data showed that either the roll sensor is also mounted in reverse, or that CARAIBES defines roll inversely compared to the coordinate frame of Autosub. Hence all roll records need to be concatenated in a text editor, and then inverted (either in the text editor, by some clever 'search & replace' or in a spreadsheet, making sure the column structure is maintained).

- *Coratt*: application of roll correction. This can be carried out as a batch on the heading corrected files, using the 'Absolute value' and 'Values from file' options, referring to the concatenated and inversed roll .txt.

- *Celeri*: creating a .vel sound velocity file from a generic text file containing the sound velocity profile under the vehicle (2 columns needed: depth and sound velocity to 2 decimal places). As all missions took place in deep water, for ease of processing a constant sound velocity profile was used.

- *CmpLay*: application of the new sound velocity profile, at the same time disabling the 'compensation layer mode'. It turns out that the EM2040 data is recorded without sound velocity profile, only with indication that the surface sound velocity (i.e. the sound velocity at the transducer) is a certain value. This is most probably the cause of the problems with the data in CARIS, and also causes incorrect projection of the soundings in Caraiibes. By applying this constant sound velocity profile (or any other that may be deemed applicable), the rays can be projected correctly.

- *Mailla*: gridding of the .mbg files to create a DTM (.dtm file). Under the cartography tab, the projection can be set. In keeping with the shipboard bathymetry data, UTM with the correct zone was chosen. Deleting isolated values and interpolating after gridding may help avoiding ragged edges and holes in the final grid.

- *Cocoul*: visualisation of the gridded data on a map (note that View3D can be used as well for a 3D view, but may need special graphics settings in the Linux emulator).
- *Odicce*: cleaning module of CARAIBES, can be used to clean data, or to carry out diagnostics, as the soundings of each line/file can be displayed in different colours. The EM2040 data were very stable and contained minimal noise, which means no cleaning was necessary during the cruise.
- *CalBat*: calibration module - was used to check for calibration, which was deemed sufficient.
- *MntAsc*: exportation of .dtm file to .flt (& associated .hdr) for direct importation into ArcGIS (after specification of the Spatial Reference).

The EM2040 data were of very good quality, with hardly any noisy spikes. The sound velocity profile can probably still be improved, there still seemed to be a limited amount of 'frownies' left. Also the roll correction left a very small amount of roll on the data, showing up in shaded relief images. The main issue, however, was positioning: when integrated into the GIS, and compared to HyBIS video imagery, there seemed to be inconsistencies. Autosub6000 drifts off position during descent, an effect which can be corrected through its range-only navigation correction procedure at the start of each mission ('navigation box'). However, detailed analysis showed that a simple offset for the bathymetric grids was not sufficient. Using clearly identifiable features on the seabed (small volcanic cones, narrow depressions etc.), the EM2040 data were tied in with the shipboard bathymetry, using the Georeferencing function within ArcGIS (effectively rubbersheeting the grids). It appeared that all grids had to be stretched, which seems to indicate that the Autosub inertial navigation may have problems correctly estimating the distance travelled.

Autosub EM2040 Multibeam Backscatter (200 - 300 - 400kHz)

Processing of the Multibeam backscatter was carried out in the PRISM software. Transfer of data to PRISM was done via the Kongsberg Replay system which converts the raw .all files to proc format which can be read by PRISM. Usually, as the internal names in the .all files are set to a single value, the conversion to proc must be carried out on each file individually to avoid overwriting them. However in this case, as the .all files had to be concatenated, the replay was carried out in a single large file per mission.

The resulting proc was then converted in PRISM using a similar process as for the shipboard EM120 backscatter:

- Conversion to PRISM format in the cdf directory: *em710cdlinux*
- *do_create_index* to create index file in cdf directory, copy to parent directory
- *do_make_nav* in the cdf directory (no-header option), copy to nav folder
- creating a single map directory in the parent directory which covered the full extent of each mission with *mapcreate*. A Mercator projection with standard parallel (latitude of true scale) was once again chosen.
- Copying of *commands.cfg* file from the library of available commands in the PRISM/dat folder. It contains the following commands:

```
mrgnav -i %1 -o %0 -n navfile.nav -l 0,0
```

```
filter -i %1 -o %0 -b 1,21 -z -v 130,255
```

```
filter -i %1 -o %0 -b 1,301 -h -v 130,255
```

```
filter -i %2 -o %0 -b 31,301 -L -v 130,255
```

```
wtkombo -i %2 , %1 -o %0 -c 1,1 -a -128
```

```
restorehdr -i %1 -h %5
```

```
resol -i %2 -o %0 -r res -a
```

```
# shade -i %1 -o %0 -n 128 -t 1,254
```

-prismrange command in the map directory (eliminating coverage overlap by direction priority), leaving the option to ignore nadir sections out. The backscatter data were processed to 2.5 m or 1m pixel resolution depending on Autosub height.

The resulting .lan files were directly imported into ArcGIS and georeferenced to match the extent of the bathymetric maps and displayed with high backscatter in white and low backscatter in black. As with the bathymetry, the data heading has an offset of 180 degrees. As a result of lacking vehicle heading information in the .cdf files, no offset could be applied during the cruise, but post-processing back at base should repair this problem. In addition, more optimal settings of the filters may be required, as the backscatter mosaics did not provide a lot of detail (Figure 3).

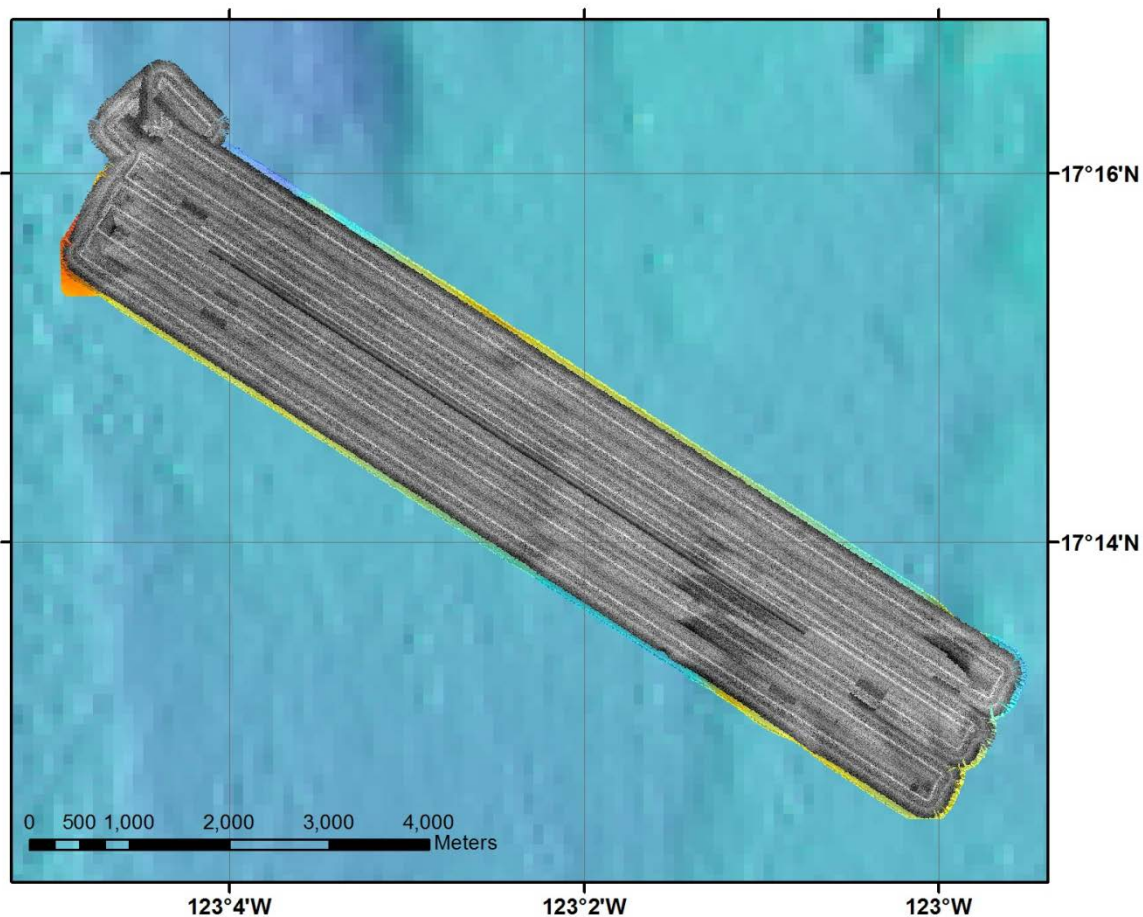

Figure 3. Detail of EM2040 backscatter mosaic from M78. Note the along-track striping and the fact that the data is mirrored on each track as a result of the 180deg heading offset. Further processing will be necessary to obtain optimal results.

Autosub Edgetech low frequency Sidescan (120kHz)

Edgetech sidescan sonar data were collected in a number of configurations, depending on mission aims. Low-frequency data were collected at altitudes of 100m (simultaneously with some of the EM2040 200kHz multibeam data), 50m (nominal optimal altitude for the low-frequency sidescan sonar, occasionally simultaneously with 300kHz EM2040 multibeam data), 40m (simultaneously with EM2040 300kHz multibeam data). The Edgetech .jsf data files contain the low and high frequency sidescan data as well as the chirp sub-bottom profiler, all collated together. The Edgetech Discover 4200-FS software was used to convert the .jsf format data into XTF format. This has the advantage of viewing the data whilst being converted. A few files were corrupted (especially M78), and they were repaired with the SalvageCorrupZeros.exe routine provided by Edgetech.

Conversion of the sidescan is tempered by the gains set on the video display, hence those were set to:

Low Freq: Gain 0dB TVG 0dB/100m

The .xtf data were then converted into PRISM format (.cdf) using the *reson2prism* program. For missions with extensive Edgetech datasets, the *loopfile* command was used for batch-processing. The original data have an across-track resolution of ~3.5 cm but as the ping rate was 2Hz (75cm) the data were averaged and subsampled by a factor of 4 to ~14 cm (with slight variations between missions). The number of samples was also limited to 5000, which is close to the total number after subsampling (5174), eliminating the noisy far ranges from the swaths, but keeping the maximum amount of information.

Navigation was obtained separately from Autosub data files (Mxx_EdgetechNav.txt). Two versions of these files are generally available: raw, and corrected for drift during the descent (calculated from the range-only navigation correction). As with the multibeam processing, the final results proved to still be misplaced, hence where possible the original navigation was used (before drift correction), and georeferencing was applied on the resulting maps in ArcGIS. Heading was calculated from track heading as there seemed to be a lot of variation in the vehicle heading. Vehicle altitude was also not available and was therefore measured from the first return (*do_alt*).

Maptiles were generally created manually, to have a minimum number of maps, cutting the sometimes irregularly shaped surveys at the most optimal locations (*mapcreate* command).

Sonar processing and geometrical correction used a 45° course deviation factor for segments and a 50cm pixel resolution. Overlap of coverage was eliminated by direction priority and range location parameters (*prismrange*). The commands.cfg file contained the following:

```
mrgnav_inertia -i %1 -o %0 -u 0 -r 0.0,0.0 -n navfile.veh_nav
```

```
tobslr -i %1 -o %0 -r0.1405 , res # 400 range
```

```
edge16 -i %1 -o %0 -m
```

```
shade_tobi -i %1 -o %0 -n 1000
```

```
# shade -i %1 -o %0 -n 100
```

```
# shade3 -i %1 -o %0 -c navfile
```

```
# shade5 -i %1 -o %0 -c navfile
```

```
filter -i %1 -o %0 -b 1,351 -h -v 1,5000
```

```
filter -i %2 -o %0 -b 21,351 -l -v 1,5000
```

```
wtcombo -i %2 , %1 -o %0 -c 1,1
```

```
restorehdr_tobi -i %1 -h %5
```

```
lowpass2b2 -i %2 -o %0
```

```
restorehdr_tobi -i %1 -h %3
```

```
widealt -i %2 -o %0 -h -l 500
```

Where surveys were split into several maps, the results were collated in ERDAS Imagine and mosaiced into a single image, which could be imported into ArcGIS and georeferenced.

Autosub Edgetech high frequency Sidescan (410kHz)

The high frequency setting of the Edgetech sidescan sonar was used both for short dedicated transects (15m altitude) and during the photo transects carried out by Autosub. Initial tests during M79 showed that with 3m altitude, the high-res sidescan sonar data, although not optimally placed, still provided valuable information about the seabed directly around the photographs. The extremely low incidence angles at this altitude allowed to image very shallow depressions, which could also be seen faintly in the 15m altitude data, but not in the low frequency datasets (Figure 4). From that point onwards, high-resolution data were collected simultaneously with all photo transects.

Processing of the high frequency sidescan sonar data was very similar to the processing of the low frequency data. During the conversion from .jsf to .xtf, the following Gain settings were used in the Discover software:

High Freq: Gain 15dB TVG 0dB/100m

The .xtf data were then converted into PRISM format (.cdf) using the *reson2prism* program, making use of *loopfile* where necessary. The original data have a sample resolution of 1.152cm but as the ping rate was 6Hz (25cm) the data were averaged and subsampled by a factor of 4 to 4.61cm for the 15m altitude data, and by a factor of 2 to 2.34cm for the 3m altitude data. Data files were given 4500 (15m altitude) or 8000 samples per side (3m altitude). Heading was calculated from track heading and vehicle altitude was measured from the first return (*do_alt*). Maptiles were again created manually, and the commands.cfg file contained the following programmes (adapting the resolution where necessary):

```
mrgnav_inertia -i %1 -o %0 -u 0 -r 0.0,0.0 -n navfile.veh_nav
```

```
widealt -i %1 -o %0 -p -h
```

```
tobslr -i %1 -o %0 -r0.0234 , res # high freq 110m 6 Hz subsamp 5
```

```
edge16 -i %1 -o %0 -m
```

```
shade_tobi -i %1 -o %0 -n 1000
```

```
# shade -i %1 -o %0 -n 100
```

```
# shade3 -i %1 -o %0 -c navfile
```

```
# shade5 -i %1 -o %0 -c navfile
```

```

filter -i %1 -o %0 -b 1,351 -h -v 1,5000
filter -i %2 -o %0 -b 21,351 -l -v 1,5000
wtcombo -i %2 , %1 -o %0 -c 1,1
restorehdr_tobi -i %1 -h %5
lowpass2b2 -i %2 -o %0
restorehdr_tobi -i %1 -h %3
widealt -i %2 -o %0 -h -l 50

```

Sonar processing and geometrical correction used a 45° course deviation factor for segments and a pixel resolution ranging from 10 to 20cm (see Table 1). Overlap of coverage was eliminated by direction priority and range location parameters (*prismrange*).

Results were again collated in ERDAS Imagine and mosaiced into a single image where necessary.

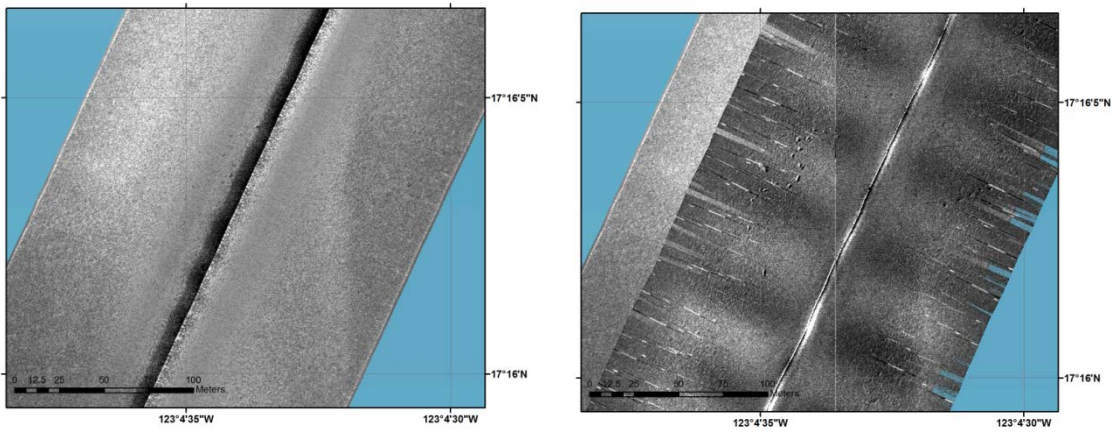

Figure 4. Detail of the 15m and 3m altitude sidescan sonar data, illustrating the occurrence of strings of small circular depressions.

Autosub EdgeTech Chirp profiler (2-13 kHz sweep)

In addition to the sidescan sonar, the Edgetech system also contains a chirp profiler, which again was used in a number of configurations. Two different source sweeps were used, either a 16ms sweep, optimised for 15m altitude work but also recording data at 50m, and a 5ms sweep which was the preferred option for 3m altitude work. Unfortunately the sweep had to be chosen at the start of each mission, and was fixed for the entire mission, hence for each mission a decision had to be made which dataset would be most useful. Basically the 16ms sweep was too long to be used at 3m altitude, and would interfere with the first return and upper sections of the profiles. However, the 5ms sweep does not carry enough energy to give anything else than the seabed reflector at 50m altitude, and is also quite weak at 15m altitude. Table 1 gives the information as to which sweep was used for which mission.

Preliminary data processing was carried out on the incoming data to be able to visualise the profiles, although further processing at base will be necessary to include the correct time delay related to the Autosub depth, amongst others. Processing consisted of three steps:

- inclusion of navigation information in the .jsf files. A Matlab routine (*jsf_nav_modified.m*) written by Melis Cevatoglu from NOC was used for this step. Required input: original .jsf file and navigation data provided by Autosub team (_10HzMxx). Output: updated .jsf file
- conversion to SEG-Y format, using the programme *jsf2segy* in a Linux environment (programme version adapted by Melis Cevatoglu). Input: nav-updated .jsf file, output (-o): segy file, options used: -a (use the analytical data rather than the raw data).
- visualisation through the SeisUnix command: *segyread tape=inputfile.segy endian=0 | segyclean | supsimage perc=98 > outputfile.ps*

The resulting profiles showed interesting details of the sub-seabed sediment thickness and the occurrence of shallow rock formations (Figure 5). In the 'ridge' and 'flat' areas, they also provided a hint of a high amplitude reflection at ca. 10-15ms TWT depth. The 3m altitude profiles are heavily affected by the vehicle motion, though, and will need further post-processing before interpretation can be carried out (Figure 6).

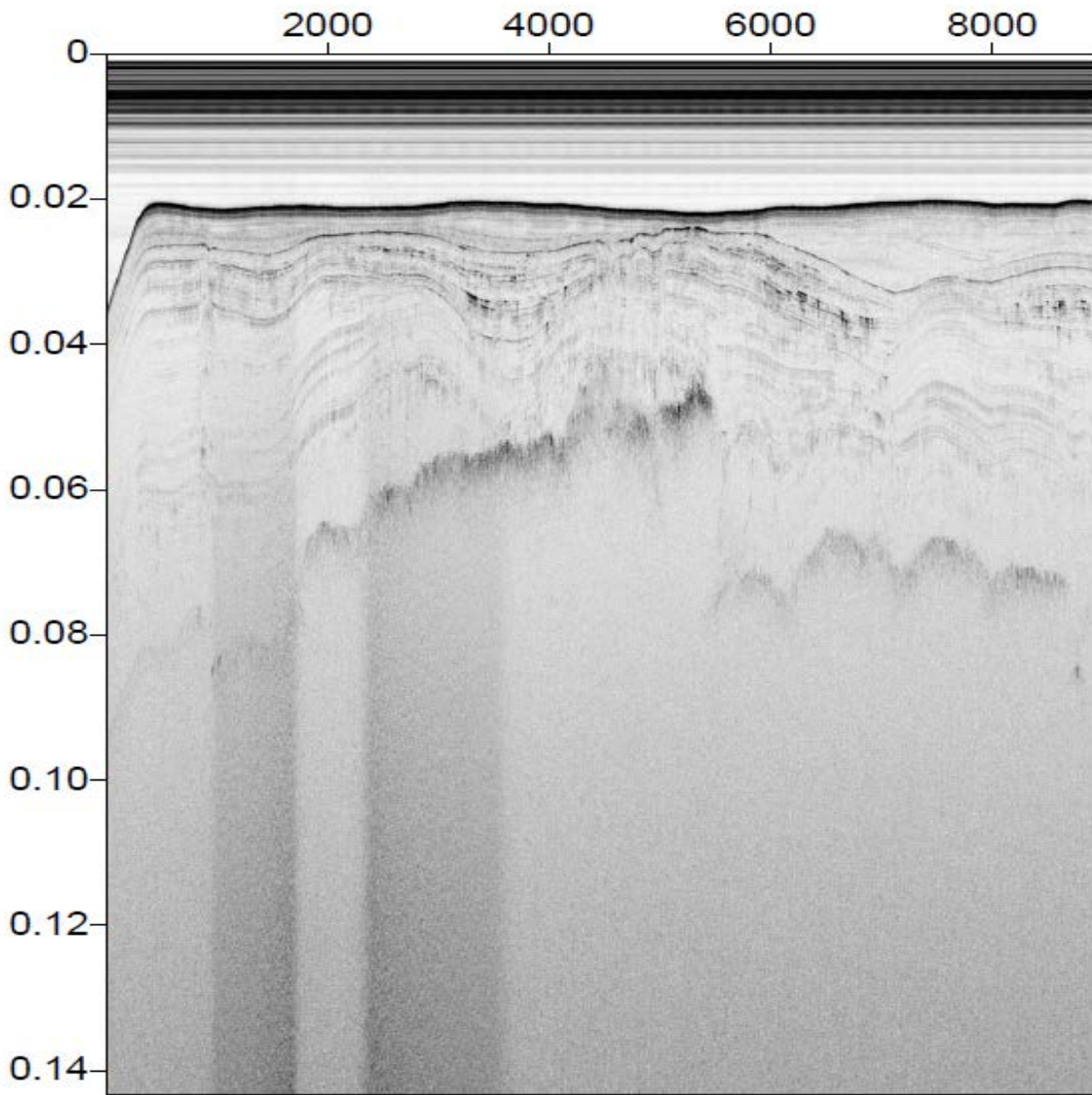

Figure 5. Example CHIRP profile collected at 15m altitude, 16ms sweep, M79. X-axis: trace number, Y-axis: TWT below the Autosub vehicle. Note the basement rock, sediment packages with basin infill and onlapping reflectors, and the high amplitudes in at least 2 reflectors

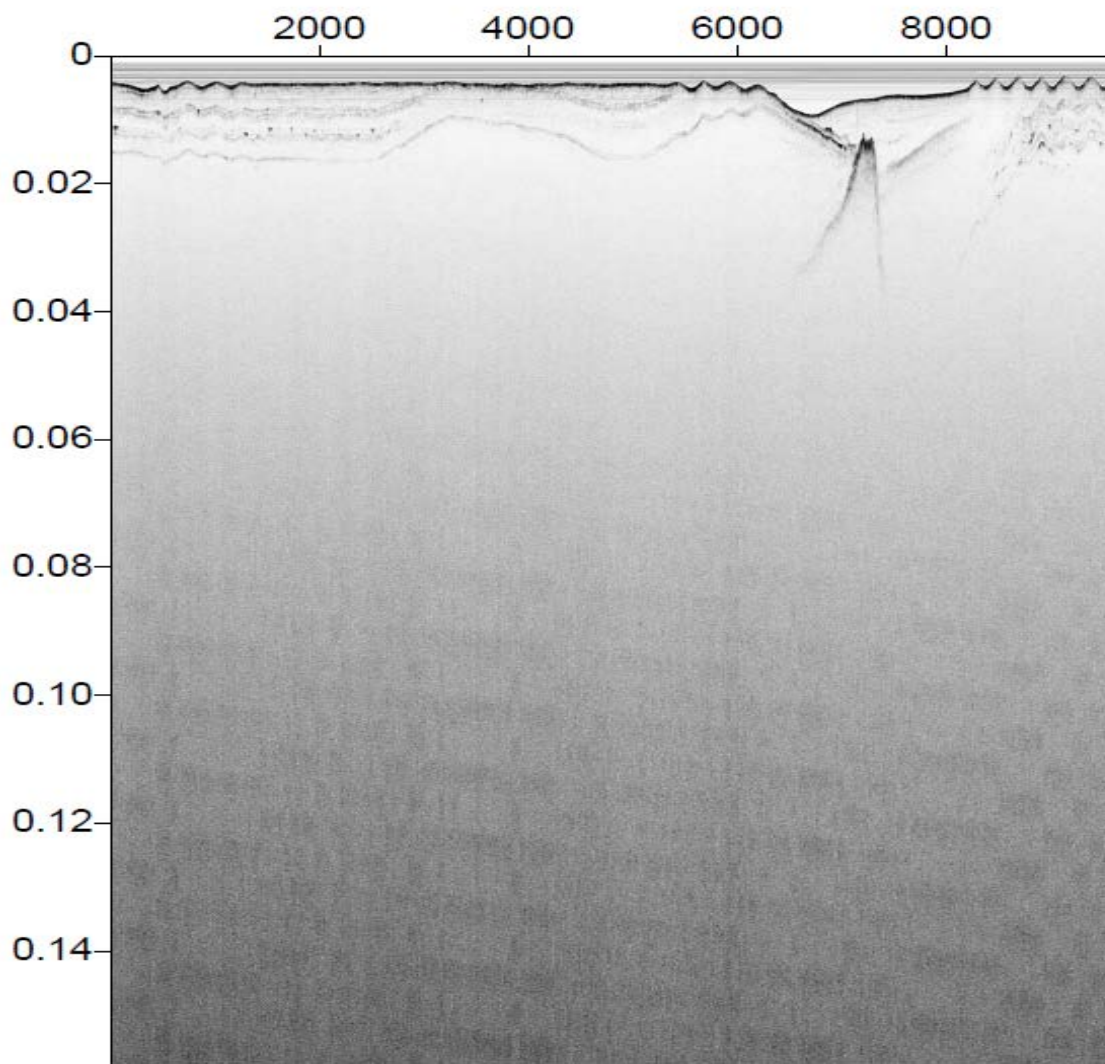

Figure 6. Example CHIRP profile collected at 3m altitude, 5ms sweep, M81. X-axis: trace number, Y-axis: TWT below the Autosub vehicle. Again basement can be seen, as well as sediment packages and high amplitude reflectors. The profile is affected by the Autosub depth variations as the vehicle was working close to the seabed (wavy pattern).

Survey design

Erik Simon and Daniel Jones

APEI-4 Study areas

Our operations in the APEI were constrained within a 5,500 km² area of seafloor approximately 20 nautical miles NNE from the South Western limit of the APEI-4 of the CCFZ (Polygon SE corner: 123° 5' 34.724" W, 16° 46' 6.359" N; NW corner: 122° 27' 47.481" W, 17° 31' 45.262" W). We completed a complete EM120 swath bathymetry survey of this area and EM120 swath bathymetry data gridded at 100m resolution was used to create bathymetric derivatives for survey planning. In the bathymetry data several morphological features were clearly visible in the region. There was a range of north to south ridges and troughs, some relatively large flat areas and a chain of seamounts to the south of the survey area. To try and capture this variation we designed a stratified random survey, which included the top of the ridges, the base of the troughs and flat areas. We wanted to use an objective method to delineate polygons of interest, upon which we would base the remainder of the sampling strategy. As a result, we used a range of bathymetric derivatives to determine our polygons of interest. Broad-scale bathymetric position index (BPI), slope and terrain ruggedness (TRI) layers were calculated from the EM120 data using SAGA software. The BPI was calculated using an inner radius of 500 m and an outer radius of 10,000 m. The TRI was calculated with a 500m round radius. Slope was calculated with the slope tool in ArcGIS 10.1. Contours were drawn using ArcGIS representing the threshold values. These were used to delimit polygons (Figure 7). Four polygons of interest, at flat sites (at two depths), a ridge and a trough, were defined using the criteria described in Table 2. Given that mining operations would only be possible on flat seafloors (Kuhn *et al* 2012), we delimited the Flat and Deep Plain polygons along areas with slope gradients below 3°, so that these 2 stratum could be considered homologous to other potentially exploitable seafloors along the CCFZ. All data were typically projected using WGS 1984 UTM zone 10 North projection.

Table 2. Classification criteria used to delimit each of the 4 final stratum selected for sampling within the APEI-4. In bold: primary selection criteria.

| Stratum | Depth band (m) | bBPI index | TRI index |
|------------|---------------------|--------------------|----------------|
| Flat | 4100 to 4200 | -100 to 50 | 0 to 50 |
| Deep plain | 4200 to 4300 | -100 to 50 | 0 to 50 |
| Trough | 4200 to 4300 | -100 to -50 | 0 to 150 |
| Ridge | 4000 to 4100 | 50 to 100 | 0 to 150 |

Sampling locations

Coring

Coring sampling locations were selected using a stratified random sampling design. We determined the sampling stations by randomly allocating 5 points within each stratum polygon, with a minimum separation of 100m, using ArcGIS "Create Random Point" tool (Table 3). A mega core and a box core were deployed on most of these 20 locations. In addition, a gravity core and a CTD per stratum were deployed on all four station 1 points.

Acoustics datasets

High resolution acoustic data from the Flat, the Ridge and the Trough strata were recorded using the Autosub6000 AUV at varying depths. On the Flat and Ridge areas a 10,000 x 1800 meter rectangle was drawn across the polygon covering the central areas of seafloor (this was the swath area covered by 6 parallel autosub6000 lines at 100m altitude). Given the narrower shape of the Trough area, we delimited a 9,000 x 1200m rectangle along the maximum width of the area to undertake the AUV acoustic survey (further information below).

Imagery

The towed camera system HyBIS and the Autosub6000 were used to record photographic transects on the seafloor of the Flat, the Ridge, and the Trough areas. AUV transects were fitted within the rectangles where acoustic data was recorded for each of these 3 strata. HyBIS photo transects were conducted across a randomly selected point of each

polygon. This points were selected by creating a box (maximum size; 500 x 1000 m) per stratum to generate a random point enclosed within it, using the “Create Random Point” tool of ArcGIS (further information below).

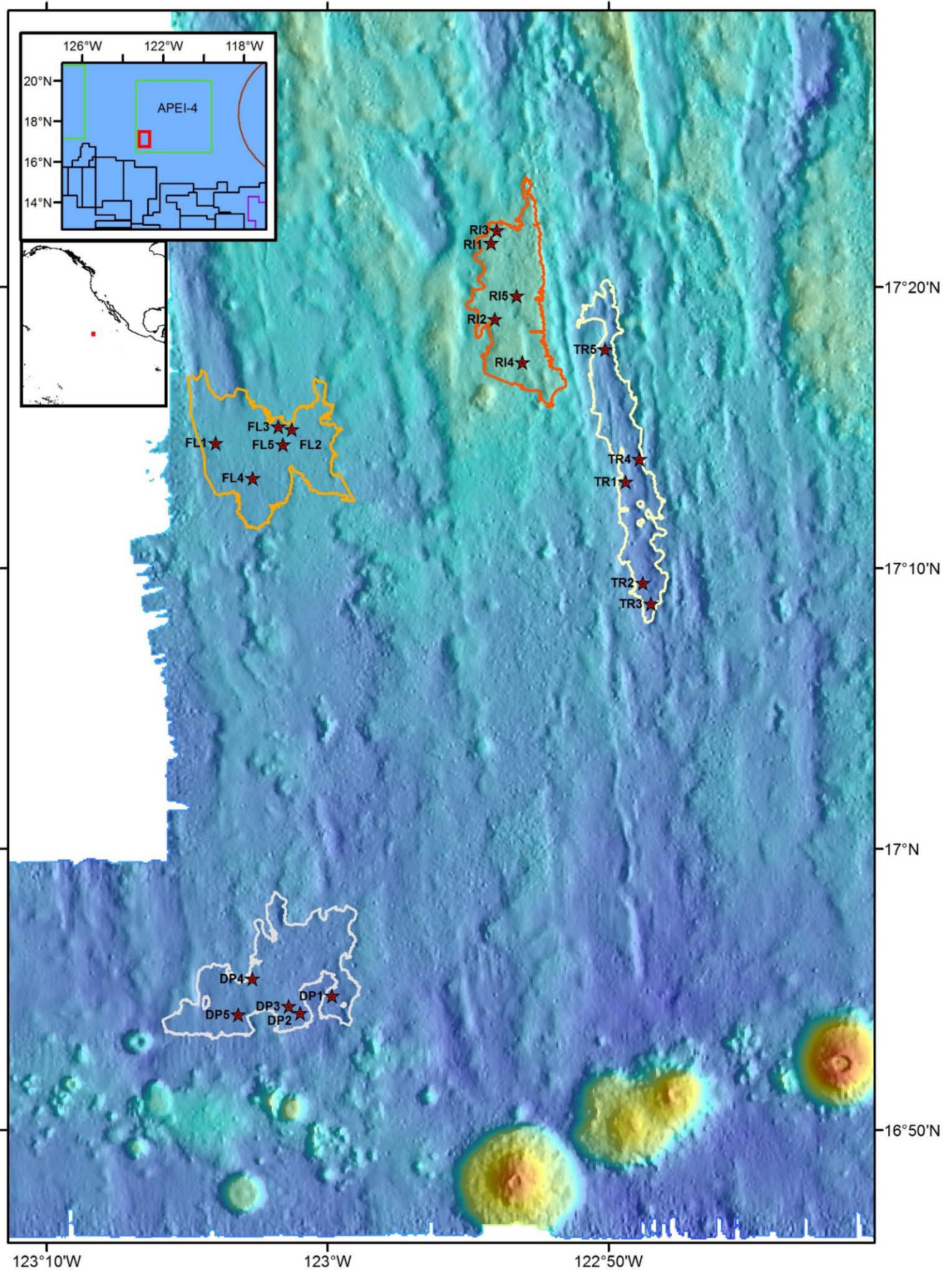

Figure 7. Chart illustrating locations of each of the four strata delimited within the APEI-4 zone shown with JC120 swath (100m resolution) as base map. Coring locations depicted with a red star. (Strata. DP: Deep Plain; FL: Flat; RI: Ridge; TR: Trough)

| Stratum | Latitude | Longitude |
|--------------|---------------|----------------|
| Deep Plain 1 | 16° 54.771' N | 122° 59.842' W |
| Deep Plain 2 | 16° 54.156' N | 123° 0.974' W |
| Deep Plain 3 | 16° 54.407' N | 123° 1.380' W |
| Deep Plain 4 | 16° 55.381' N | 123° 2.674' W |
| Deep Plain 5 | 16° 54.106' N | 123° 3.178' W |
| Flat 1 | 17° 14.448' N | 123° 3.978' W |
| Flat 2 | 17° 14.934' N | 123° 1.277' W |
| Flat 3 | 17° 15.031' N | 123° 1.754' W |
| Flat 4 | 17° 13.198' N | 123° 2.669' W |
| Flat 5 | 17° 14.389' N | 123° 1.592' W |
| Ridge 1 | 17° 21.564' N | 122° 54.182' W |
| Ridge 2 | 17° 18.850' N | 122° 54.053' W |
| Ridge 3 | 17° 22.017' N | 122° 53.977' W |
| Ridge 4 | 17° 17.313' N | 122° 53.073' W |
| Ridge 5 | 17° 19.685' N | 122° 53.273' W |
| Trough 1 | 17° 13.069' N | 122° 49.391' W |
| Trough 2 | 17° 9.466' N | 122° 48.784' W |
| Trough 3 | 17° 8.729' N | 122° 48.497' W |
| Trough 4 | 17° 13.873' N | 122° 48.897' W |
| Trough 5 | 17° 17.778' N | 122° 50.128' W |

Table 3. Coordinates of each of the coring locations selected within each stratum.

Hydraulic Benthic In Situ Sampler (HyBIS)

Erik Simon

HyBIS (Hydraulic Benthic In Situ Sampler) is a towed camera platform equipped with two video cameras and a stills camera system. Video was recorded using a forward-looking *Bowtech* L3C-550C and a vertically-mounted *Insite Pacific* Super-Scorpio video cameras, the latter is also used to take stills (Figure 8a and B). The HyBIS system also has an additional camera facing upwards (towards the wire) for piloting purposes. HyBIS has three sleds that can be mounted below a main frame: a benthic grab, a hydraulic manipulator for directed sampling and a vertical video camera system. The video camera is either on the top of the vehicle (Grab and manipulator mode) or on the sled (vertical video mode). When the grab unit is mounted, *Bowtech* video camera gets reallocated vertically-looking towards the seafloor across the grab, in order to use the higher resolution Scorpio as forward facing device (Figure 8c).

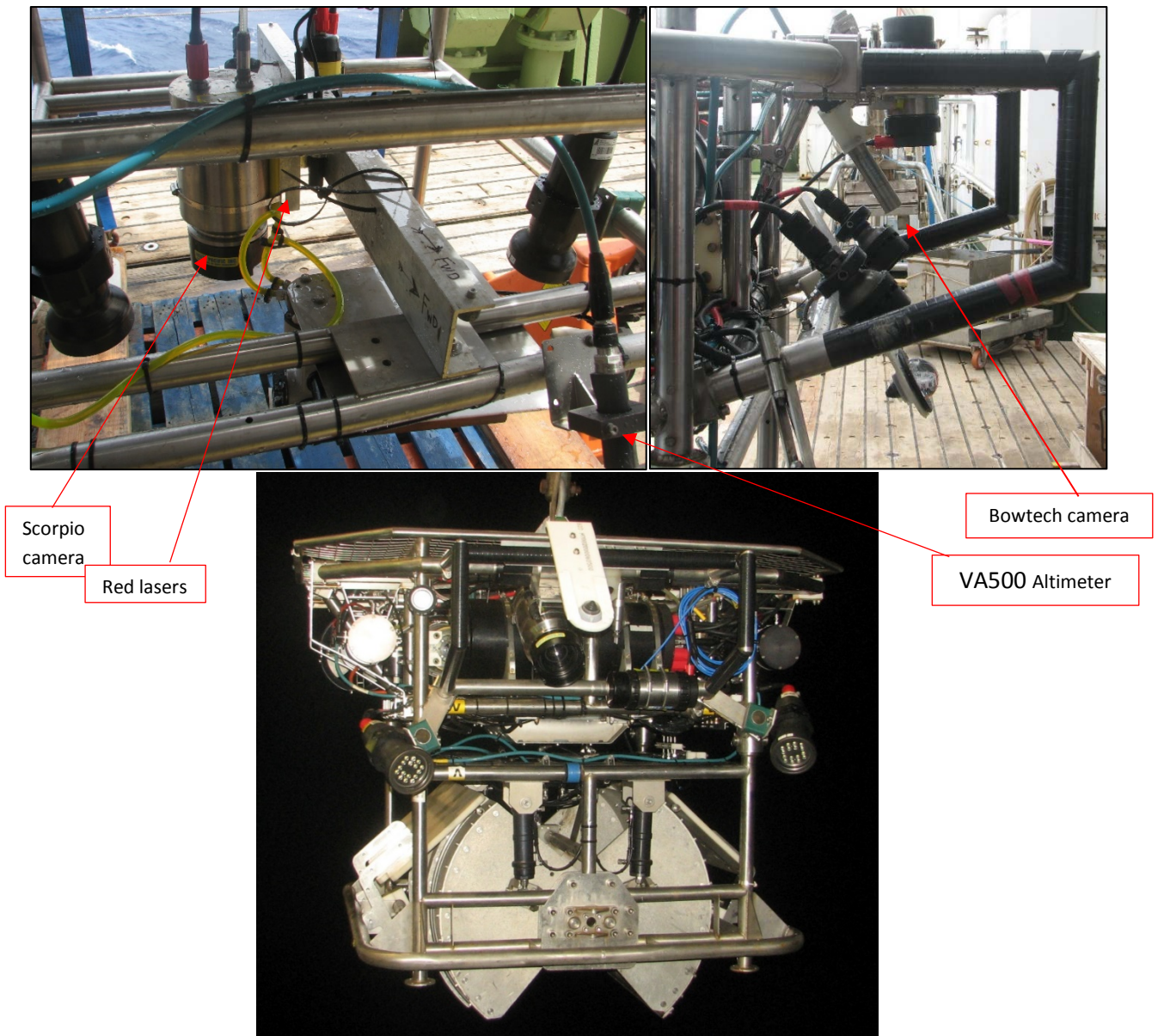

Figure 8. HyBIS device in two different configurations; Top: HyBIS mounted for only image recording purposes; Bottom: HyBIS mounted with attached grab subunit. a) Oblique view of bottom area depicting the vertical facing camera and lighting system. b) Side view of forward looking camera. c) Frontal view of HyBIS main and subunit frames. *Note the different positioning of the Super-Scorpio camera in picture c).

The forward facing camera was mounted at an angle of 58° from the horizontal frame (the Bowtech camera was always allocated with this positioning, with the only exception of Dive 01). The Scorpio video camera was vertically mounted 43cm from the base of the frame, and had two parallel red lasers attached on the case 110 mm apart. The lighting system for the vertically facing frame was composed by two 28,000 lumens LED lights (Aphos 16) mounted vertically in Dives 01 to Dive 03. We added a third light up from Dive 04. The forward facing system had two 2,600 lumens LED lights (Multi-SeaLite), also mounted with the same angle of the camera. HyBis was also equipped with a Valeport VA500 Altimeter connected to a 500kHz transducer that measured altitude and pressure of the device every second.

| | | |
|--------------------------|------------------------------------------------------|-------------|
| Focus Range | 203mm (8 inches) to Infinity | |
| Sensor type | SONY HDR-CX560VE | |
| Angle of view | 3.8mm(26.3mm) | 38mm(263mm) |
| In water | Wide angle | Telephoto |
| Diagonal | 72° | 9.0° |
| Horizontal | 59° | 7.4° |
| Vertical | 44° | 5.5° |
| Lens Focal Length | (Video) f=3.8mm to 38mm (Photo) f=26.3mm to 263mm | |

Table 4. Super-Scorpio camera optical specification

| | |
|----------------------|-----------------------------------|
| Focus Range | 100mm to Infinity |
| Sensor type | 1/3" SONY Ex-View HAD CCD |
| Lens | 2.9mm, F2.0 |
| Angle of view | 91° Diagonal in Air, 65° in Water |

Table 5. Bowtech camera optical specification

Camera Setup

Video images from all cameras and VA500 measurements were transmitted real-time back to the vessel (via fibre-optics). Video data were directly transmitted to a data multiplexer (Focal 907-R/C), broadcasted live on deck and recorded on AJA KiStor storage modules. Both forward and vertically facing footage data were stored as 2h long videos, and backed up twice into a LaCie 8big rackmount direct-attached storage (DAS) system. Scorpio camera stills were recorded on a memory card within the camera, extracted after each dive and stored into a QNAP drive. Along all dives, all Scorpio camera settings were set to Auto mode with exception of the white balance, which was manually calibrated at the start of each dive, once the bottom reached. These settings were only modified on Dive 03, where an Iris F8 configuration was used.

No flash was used for taking stills and picture dimensions were 4672 x 2628 pixels.

HyBIS dives

Observations and navigation data of each HyBIS dive were recorded using the Ocean Floor Observation Protocol (OFOP) software version 3.2.0k on the vertical facing camera live broadcast. In parallel to the OFOP observations, a total abundance count was undertaken by a 2nd observer in all dives from Dive 02 to Dive 07.

Dive 01

Dive 01 was planned as a first reconnaissance mission, across an area with varying range of backscatter measurements in order to assess the potential colinearity between grey values and nodule cover (Figure 9). This is the only dive where the Scorpio camera was mounted in the forward facing position, and where the grab sled was mounted. A grab was taken at the end of the dive. The Bowtech camera was mounted and used from the vertical facing position.

Remarks:

- We had a navigation problem during this dive; ship coordinates were logged instead of the actual HyBIS positioning.

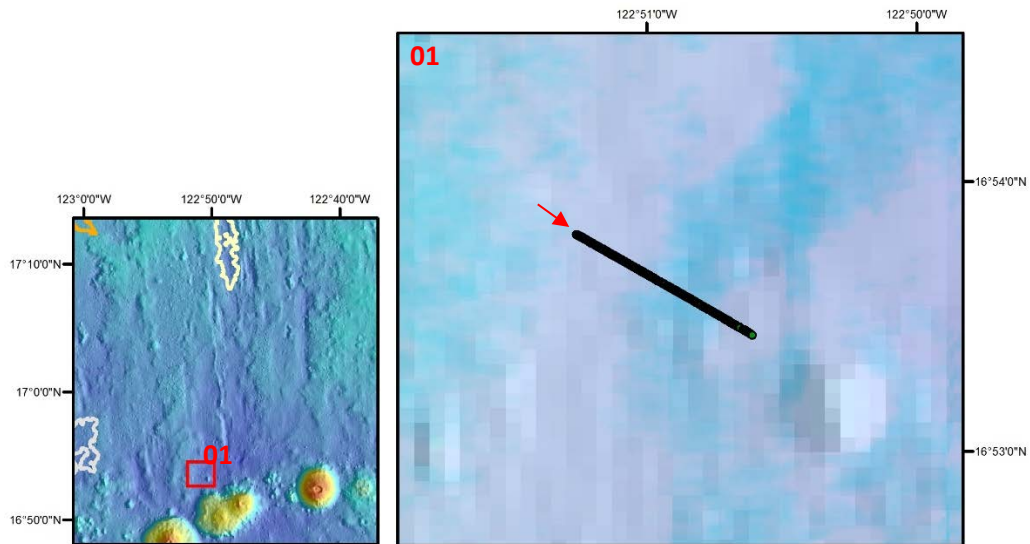

Figure 9. Chart illustrating the path followed during HyBIS Dive 01. Arrow indicates starting point.

Dive 02, 03, and 04

These three dives were planned for visual megafauna/geomorphology assessment of the three most northern study areas; Trough: Dive 02; Ridge: Dive 03; Flat: Dive 04 (Figure 10). The planned route for these dives followed 3 consecutive 2km long transects delimited across a random point allocated within each of these polygons (see Survey design).

Remarks:

- We had a navigation logging problem during Dive 02. HyBIS and ship positions were logged simultaneously into the same file. A subset of actual HyBIS positions was possible to be extracted from the logged navigation and interpolated into a final platform navigation file (by KR).
- After the planned 6km, in dives 03 and 04 we extended the dive for an extra 30 minutes.

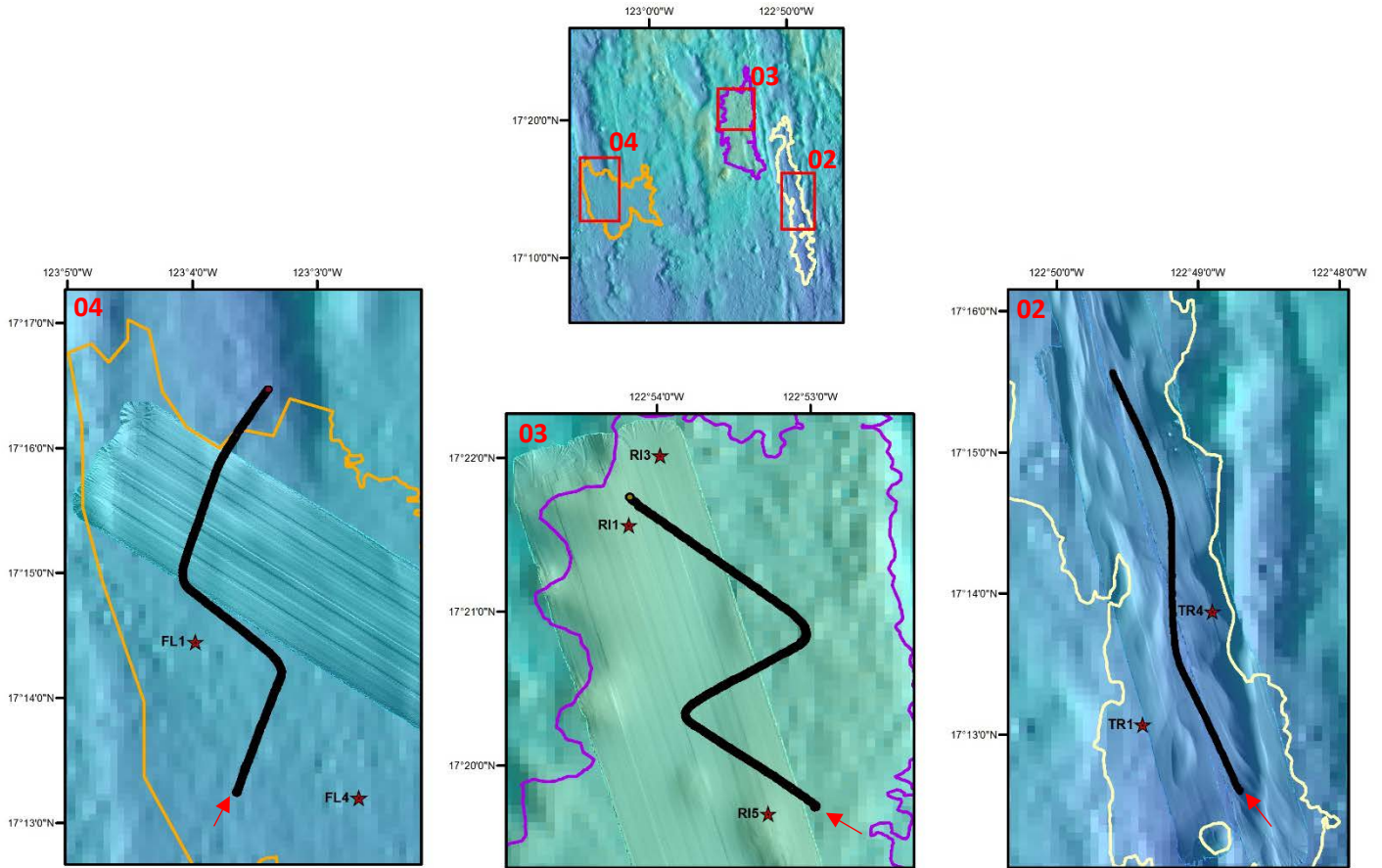

Figure 10. Chart illustrating the path followed during HyBIS Dive 01, Dive 03, and Dive 03. Arrows indicate starting points.

Dive 05

This dive was delimited along a series of topographical variations between the Trough and the Ridge study areas. The track started with a long straight line from the northern area of the Trough towards the south of the Ridge, to then turn North in order to visualise the central area of this last, where a potential rocky outcrop was detected next to a small depression.

Remarks

- The dive had to be interrupted twice due to problems with the ship which. The first was solved by pulling 30 meters up HyBIS and the second by resting the platform on the seafloor to deploy an extra 20m of cable. Hence, along the picture sequence there are two interruptions within this dive; the first happened between 04:15 and 04:36, and the second between 07:32 and 07:43.
- Due to the large length of this dive, the navigation logging had to be interrupted. The OFOP posi.txt file of the dive reached 65931 lines. We stopped and restarted logging position at 15:20, hence we obtained 2 sets of OFOP positioning files from this dive: Dive_05 and Dive_05b.
- The number of pictures taken during this dive was above the length that the camera can automatically give a name to. Hence, we had to batch rename the last subfolder containing pictures above DSC_9999; the last section of transect pictures was renamed (by BB), from ESC_0001 onwards.

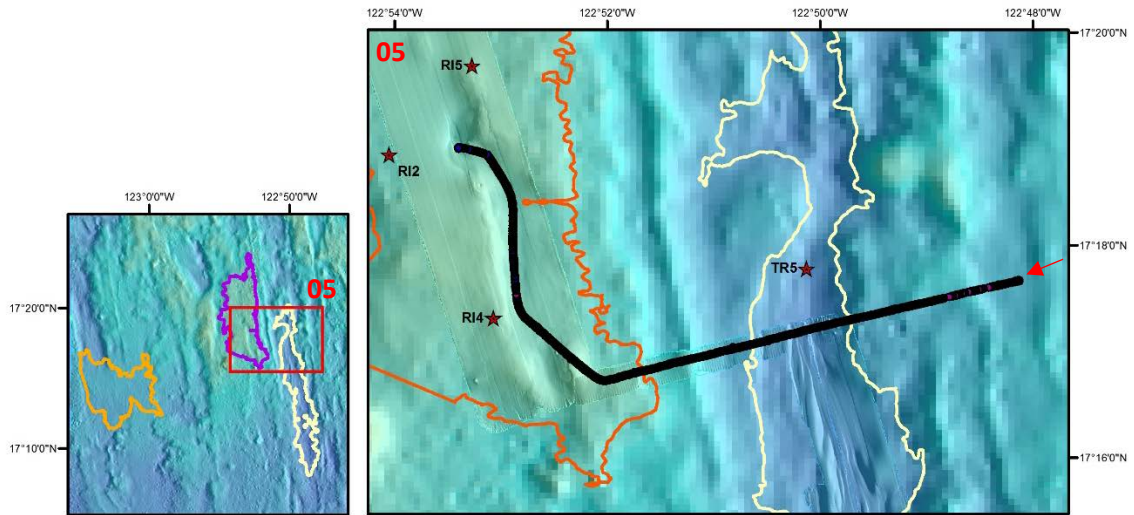

Figure 11. Chart illustrating the path followed during HyBIS Dive 05. Arrow indicates starting point.

Dive 06

This dive was delimited along the top and crater of a small volcano located within the South Eastern corner of the swath area.

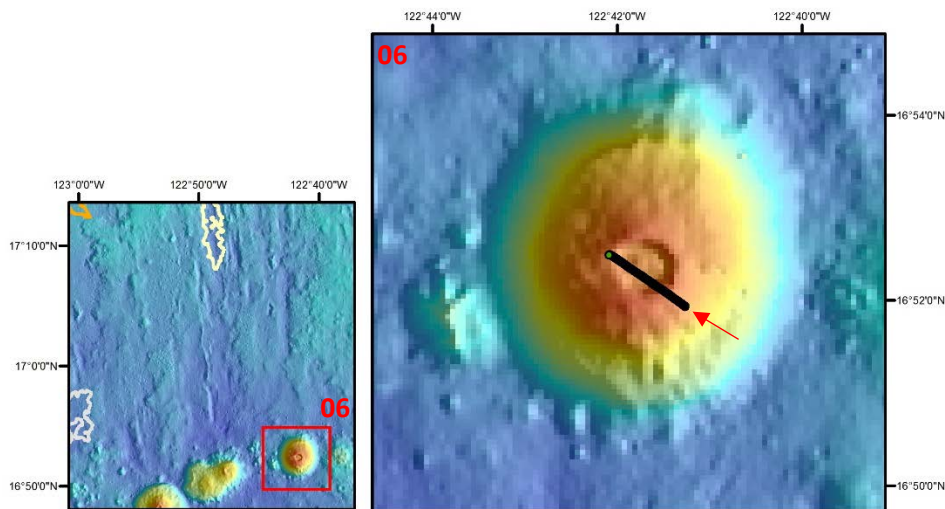

Figure 12. Chart illustrating the path followed during HyBIS Dive 06. Arrow indicates starting point.

Dive 07

This dive was carried out along a section of seafloor located North East from the UK claim zone 1 of the CCFZ.

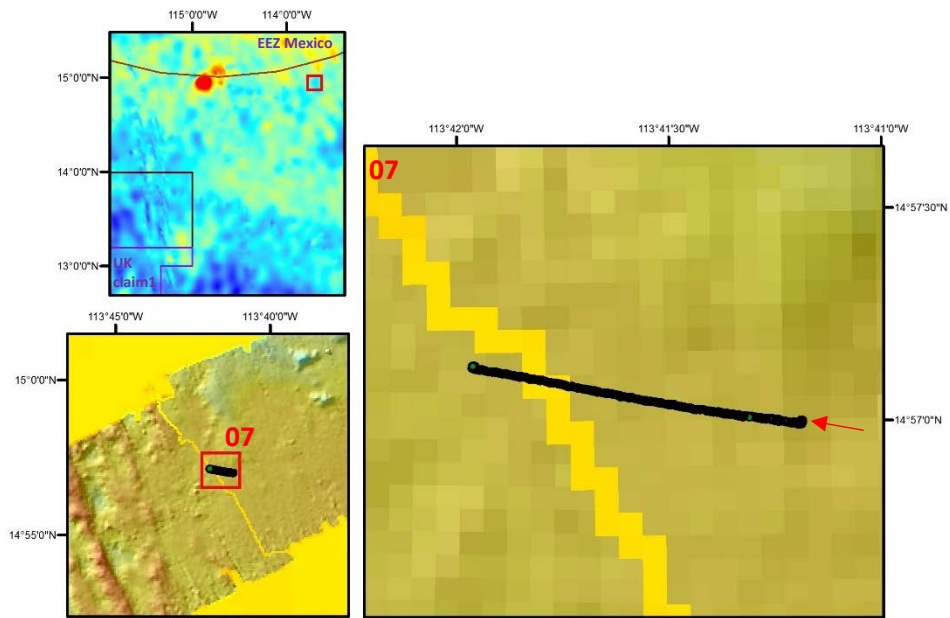

Figure 13. Chart illustrating the path followed during HyBIS Dive 07. Arrow indicates starting point.

| Mission | Station | Deployment (time) | At bottom (time) | Off Bottom (time) | On deck (time) | Depth start (m) | Depth end (m) | Lat_start | Long_start | Lat_end | Long_end | Length (m) | Num pictures | Pict. interval | Towing speed |
|---------|-----------|-------------------|------------------|-------------------|----------------|-----------------|---------------|----------------|-----------------|----------------|-----------------|------------|--------------|----------------|--------------|
| Dive 01 | JC120-005 | 04:12:02 | 05:43:46 | 10:12:08 | 12:24:03 | 4321 | 4324 | 16° 53.8138' N | 122° 51.2782' W | 16° 53.4313' N | 122° 50.6087' W | 1230 | 814 | manual | 0.2 knots |
| Dive 02 | JC120-041 | 01:29:44 | 03:54:43 | 13:12:10 | 15:15:54 | 4257 | 4030 | 17° 12.6097' N | 122° 48.7110' W | 17° 16.4617' N | 122° 50.0381' W | 5780 | 4569 | 4" | 0.4 knots |
| Dive 03 | JC120-044 | 23:25:04 | 01:42:26 | 11:00:52 | 13:23:45 | 4030 | 4021 | 17° 19.7319' N | 122° 52.9617' W | 17° 21.6339' N | 122° 54.0343' W | 6280 | 5902 | 4" | 0.4 knots |
| Dive 04 | JC120-046 | 22:49:57 | 01:06:18 | 10:47:04 | 12:49:16 | 4223 | 4248 | 17° 13.2471' N | 123° 03.6396' W | 17° 16.2935' N | 123° 03.5222' W | 6970 | 6178 | 4" | 0.4 knots |
| Dive 05 | JC120-079 | 20:58:40 | 23:32:22 | 19:31:01 | 21:22:15 | 4133 | 4013 | 17° 17.6669' N | 122° 48.1290' W | 17° 18.9115' N | 122° 53.3505' W | 12410 | 12462 | 5" | 0.4 knots |
| Dive 06 | JC120-089 | 16:08:59 | 17:16:30 | 22:13:03 | 23:52:16 | 3457 | 3412 | 16° 51.9373' N | 122° 41.2674' W | 16° 52.4733' N | 122° 42.0441' W | 1780 | 3106 | 4" | 0.2 knots |
| Dive 07 | JC120-110 | 16:35:00 | 18:24:09 | 21:00:57 | 22:41:05 | 3925 | 3929 | 14° 56.9928' N | 113° 41.1880' W | 14° 57.1024' N | 113° 41.8513' W | 1430 | 1640 | 2" | 0.3 knots |

Table 6. Summary table representing main details of all HyBIS dives undertaken during JC120.

Station No: JC120-05**Dive No: 01**

| Date (JD) | KiPro Name | Time Start (GMT) | Time End (GMT) | File Name | Comments |
|-----------|------------|------------------|----------------|-----------------|----------|
| 15111 | Spare 1 | | | JC120 Scorpio_1 | |
| 15111 | Spare 3 | | | JC120 Scorpio_2 | |
| 15111 | Spare 4 | | | JC120 Grab_1 | |

Station No: JC120-41**Dive No: 02**

| Date (JD) | KiPro Name | Time Start (GMT) | Time End (GMT) | File Name | Comments |
|-----------|-------------|------------------|----------------|-----------------|----------|
| 15119 | Spare 3 | | | JC120 Grab_2 | |
| 15119 | Spare 1 | 03:41:18:00 | 05:44:06:15 | JC120 Scorpio_3 | |
| 15119 | Spare 2 | 05:44:37:00 | 07:44:54:13 | JC120 Scorpio_4 | |
| 15119 | Pal Rec | | | JC120 Grab_3 | |
| 15119 | Spare 5 | | | JC120 Grab_4 | |
| 15119 | Spare 3 | 07:45:16:00 | 09:45:24:19 | JC120 Scorpio_5 | |
| 15119 | Spare 3 500 | 09:45:48:00 | 11:46:37:10 | JC120 Scorpio_6 | |
| 15119 | Spare 4 500 | 09:46:18 | 11:47:05 | JC120 Grab_5 | |
| 15119 | Pal Rec 250 | 11:47:10:00 | 13:29:09:21 | JC120 Scorpio_7 | |
| 15119 | Spare 2 500 | 11:47:39 | 13:29:38 | JC120 Grab_6 | |

Station No: JC120-44**Dive No: 03**

| Date (JD) | KiPro Name | Time Start (GMT) | Time End (GMT) | File Name | Comments |
|-----------|-------------|------------------|----------------|------------------|-------------------|
| 15120 | Spare 5 | 01:51:42 | 03:57:06 | JC120 Scorpio_8 | |
| 15120 | Spare 1 | 01:52:17 | 03:57:36 | JC120 Grab_7 | |
| 15120 | Spare 3 | 03:57:58 | 06:03:47 | JC120 Grab_8 | overlap 1 min off |
| 15120 | Spare 4 | 03:57:28 | 06:03:17 | JC120 Scorpio_9 | |
| 15120 | Spare 2 | 06:03:50 | 08:07:56 | JC120 Scorpio_10 | |
| 15120 | Pal Rec | 06:03:31 | 08:07:36 | JC120 Grab_9 | |
| 15120 | Spare 3 | 08:08:01 | 10:11:44 | JC120 Grab_10 | |
| 15120 | Spare 5 | 08:08:21 | 10:12:04:03 | JC120 Scorpio_11 | |
| 15120 | Spare 3 250 | 10:12:23:00 | 11:34:48:01 | JC120 Scorpio_12 | |
| 15120 | Spare 1 500 | 10:12:04:00 | 11:35:09 | JC120 Grab_11 | |

Station No: JC120-46**Dive No: 04**

| Date (JD) | KiPro Name | Time Start (GMT) | Time End (GMT) | File Name | Comments |
|-----------|-------------|------------------|----------------|------------------|-----------------------|
| 15121 | Spare 2 | 01:09:55 | 03:10:20 | JC120 Grab_12 | |
| 15121 | Spare 4 | 01:09:34 | 03:09:50 | JC120 Scorpio_13 | |
| 15121 | Pal Rec | 03:10:33 | 05:15:17 | JC120 Grab_13 | |
| 15121 | Spare 3 | 03:10:13 | 05:14:58 | JC120 Scorpio_14 | |
| 15121 | Spare 3 | 05:15:17 | 07:20:27 | JC120 Scorpio_15 | |
| 15121 | Spare 5 | 05:15:38 | 07:20:48 | JC120 Grab_14 | |
| 15121 | Spare 1 | 07:20:50 | 09:23:04 | JC120 Scorpio_16 | Problems with Pal Rec |
| 15121 | Spare 2 | 07:21:11 | 09:23:25 | JC120 Grab_15 | |
| 15121 | Spare 4 | 09:23:57 | 10:46:49:04 | JC120 Scorpio_17 | |
| 15121 | Spare 3 250 | 09:25:35 | 10:47:20 | JC120 Grab_16 | |

Station No: JC120-079. Trough to Ridge (long across)**Dive No: 05**

| Date (JD) | KiPro Name | Time Start (GMT) | Time End (GMT) | File Name | Comments |
|-----------|-------------|------------------|----------------|------------------|----------|
| 15128 | Pal Rec 250 | 23:25:25 | 01:29:18 | JC120 Scorpio_18 | |
| 15128 | Spare 2 | 23:25:27 | 01:29:22 | JC120 Grab_17 | |
| 15128 | Spare 3 | 01:30:03 | 03:33:04 | JC120 Grab_18 | |
| 15128 | Spare 5 | 01:30:00 | 03:33:02 | JC120 Scorpio_19 | |
| 15128 | Spare 1 | 03:33:25 | 05:35:05 | JC120 Scorpio_20 | |
| 15128 | Spare 4 | 03:33:27 | 05:35:06 | JC120 Grab_19 | |
| 15128 | Pal Rec | 05:35:26 | 07:34:53 | JC120 Scorpio_21 | |
| 15128 | Spare 2 | 05:35:27 | 07:34:54 | JC120 Grab_20 | |
| 15128 | Spare 3 | 07:35:14 | 09:38:13 | JC120 Scorpio_22 | |
| 15128 | Spare 5 | 07:35:16 | 09:38:14 | JC120 Grab_21 | |
| 15128 | Spare 1 500 | 09:38:39 | 11:37:35:15 | JC120 Scorpio_23 | |
| 15128 | Spare 4 500 | 09:38:42 | 11:37:39 | JC120 Grab_22 | |
| 15128 | Pal Rec 250 | 11:38:11 | 13:37:46:05 | JC120 Scorpio_24 | |
| 15128 | Spare 2 500 | 11:38:17 | 13:37:49 | JC120 Grab_23 | |
| 15128 | Spare 3 500 | 13:38:12:00 | 15:37:33:04 | JC120 Scorpio_25 | |
| 15128 | Spare 5 250 | 13:38:12 | 15:37:34 | JC120 Grab_24 | |
| 15128 | Spare 1 500 | 15:37:54 | 17:38:25:17 | JC120 Scorpio_26 | |
| 15128 | Spare 4 500 | 15:37:55 | 17:38:28 | JC120 Grab_25 | |
| 15128 | Pal Rec 250 | 17:38:48:02 | 19:39:04:05 | JC120 Scorpio_27 | |
| 15128 | Spare 2 500 | 17:38:48 | 19:39:04 | JC120 Grab_26 | |

Station No: JC120-089**Dive No: 06**

| Date (JD) | KiPro Name | Time Start (GMT) | Time End (GMT) | File Name | Comments |
|-----------|-------------|------------------|----------------|------------------|----------|
| 15130 | Spare 3 | 16:59:49 | 19:00:48 | JC120 Scorpio_28 | |
| 15130 | Spare 5 | 16:59:53 | 19:00:53 | JC120 Grab_27 | |
| 15130 | Spare 4 500 | 19:01:14 | 21:03:02 | JC120 Grab_28 | |
| 15130 | Spare 5 500 | 19:01:09 | 21:02:06 | JC120 Scorpio_29 | |
| 15130 | Spare 2 | 21:03:20 | 22:16:04 | JC120 Scorpio_30 | |
| 15130 | Pal Rec | 21:03:19 | 22:16:02 | JC120 Grab_29 | |

Station No: JC120-110**Dive No: 07**

| Date (JD) | KiPro Name | Time Start (GMT) | Time End (GMT) | File Name | Comments |
|-----------|------------|------------------|----------------|------------------|----------|
| 15136 | | 18:20:32 | 21:01:24 | JC120 Scorpio_31 | |
| 15136 | | 18:20:30 | 21:01:21 | JC120 Grab_30 | |

Table 7. Video transfer log sheet for all HD media recorded using HyBIS dives during JC120.

Autosub6000

Erik Simon and Daniel Jones

The Autosub is an automated vehicle devised to cover large distances (~100km transects) with a large payload of scientific equipment. It carries a number of instrument modules for surveying benthic or pelagic systems to depths of up to 6000m. During JC120 we used the Autosub to obtain both acoustic and visual imagery datasets, flying above the seafloor at varying altitudes, ranging from 3 to 100m.

Image collection

Camera setup

Autosub6000 is equipped with 2 photographic cameras (both the same model) positioned vertically and forward facing (oblique view). Distance between cameras is 686mm and each camera has a flash system mounted along a parallel direction to the camera angle (Figure 14). The frontal facing camera is separated 180mm from its corresponding flash, whereas the vertically camera is 430mm separated from its flash. The submersible speed was 1.2 m s^{-1} , and the interval between pictures was set at 850 milliseconds.

| | |
|---------------------------|------------------------------------|
| Serial number | 11370385 (forward) |
| Serial number | 13331848 (downward) |
| Camera model | Grasshopper2 GS2-GE-50S5C |
| Camera vendor | Point Grey Research |
| Sensor | Sony ICX625AQ (2/3" 2448x2048 CCD) |
| Resolution | 2448x2048 |
| Image pixel format | RAW8 |
| Bayer tile format | GBRG |
| Lens | 12.5mm, F2.7 |
| Focal range | 2.25m |

Table 8. Autosub6000 cameras specifications.

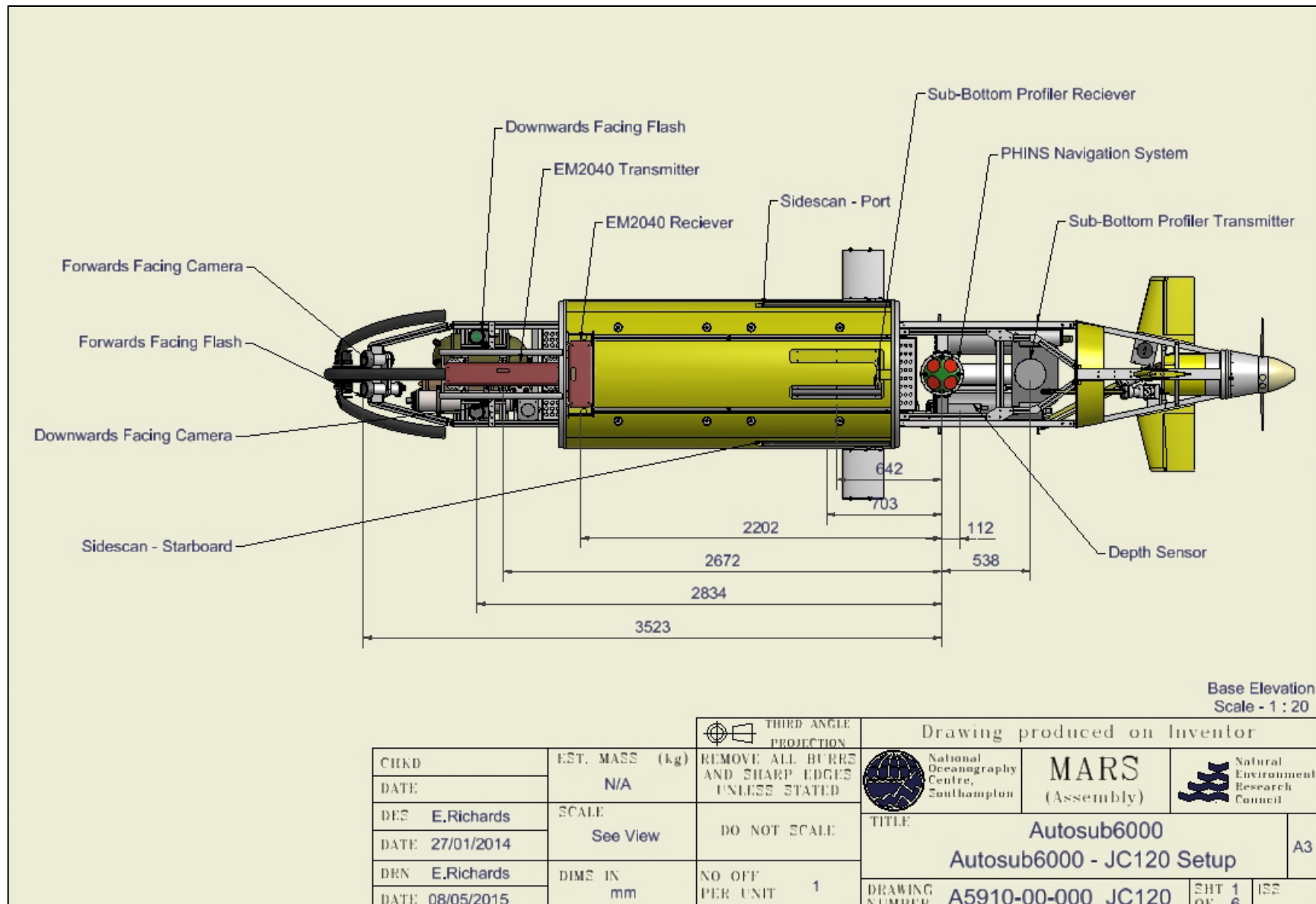

Figure 14. Lateral view of Autosub6000 showing the position of key sensors used during JC120. (Courtesy of E. Richards)

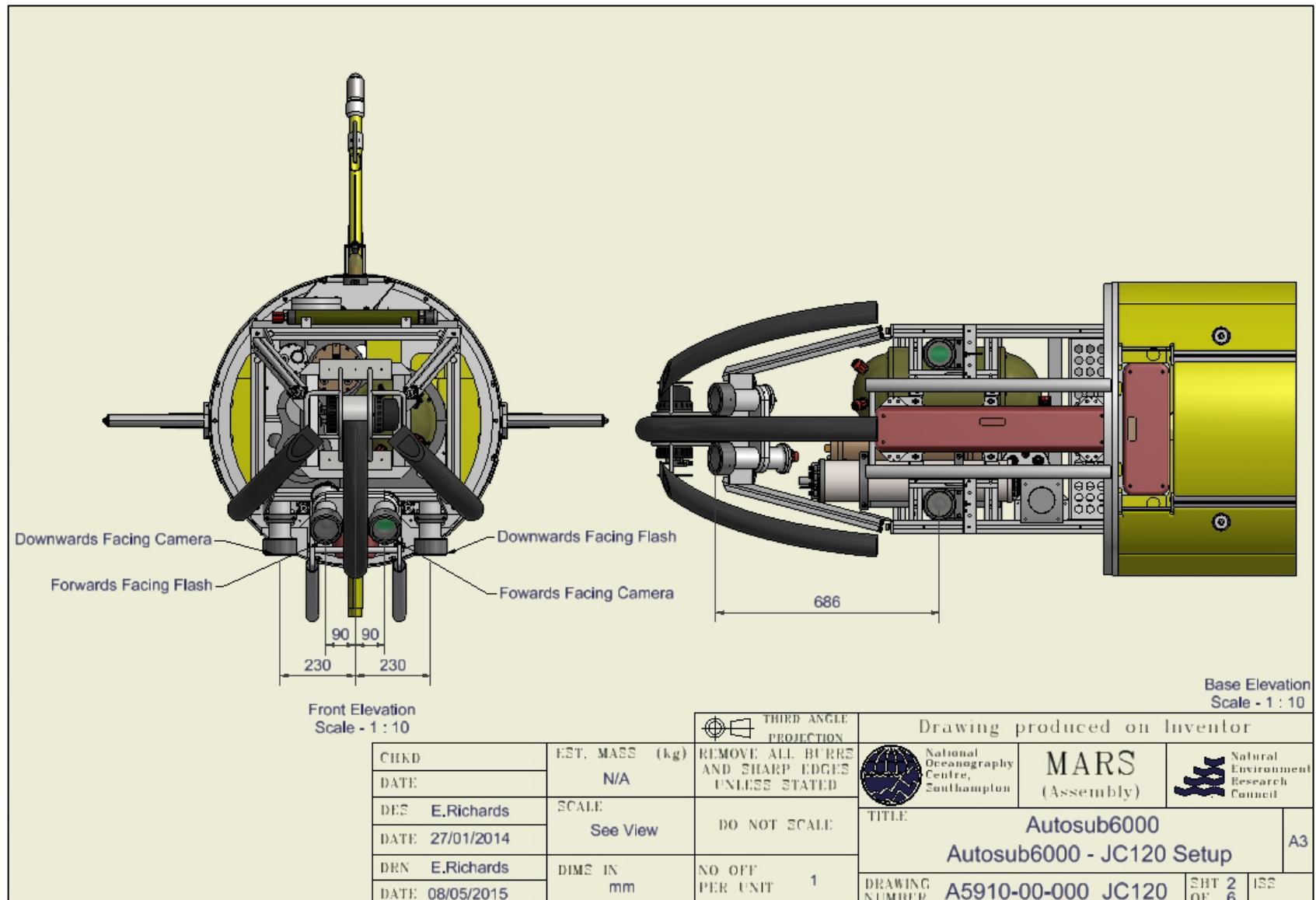

Figure 15. Frontal and lateral view of the anterior section of Autosub6000 with a diagram of the image recording system used during JC120. (Courtesy of E. Richards)

AUV Missions

Our aim during JC120 was to get as much data using the AUV as possible. We had planned to carry out 11 missions (10 at the APEI and 1 at the UK1 site). However, the success rate of the AUV was low, so we had to optimise the missions to obtain as much survey data from the three northern strata (flat, ridge and trough) as possible in each mission. As an additional constraint, we had to obtain and analyse AUV swath data prior to each photographic mission to check for dangers to the AUV prior to deployment. We were able to undertake 5 successful missions (from a total of 14 attempted missions). In a given mission, 3 different measurements could be undertaken within the limits of the AUV battery: i) Multibeam at varying depths and frequencies (EM2040), ii) Sidescan sonar at varying depths and frequencies (Edgetech), and/or iii) photographic transects at 3m altitude (Grasshoper 2 cameras).

Mission 78

We designed this mission to collect EM2040 swath and sidescan sonar data at 100m altitude, and sidescan data at 50, 15 and 3m altitude. These extra 3 levels of edgetech data were devised in order to test the efficiency of sonar data recorded at different depths. The 15m and 3m altitude parts of this mission were not run owing to vehicle safety considerations.

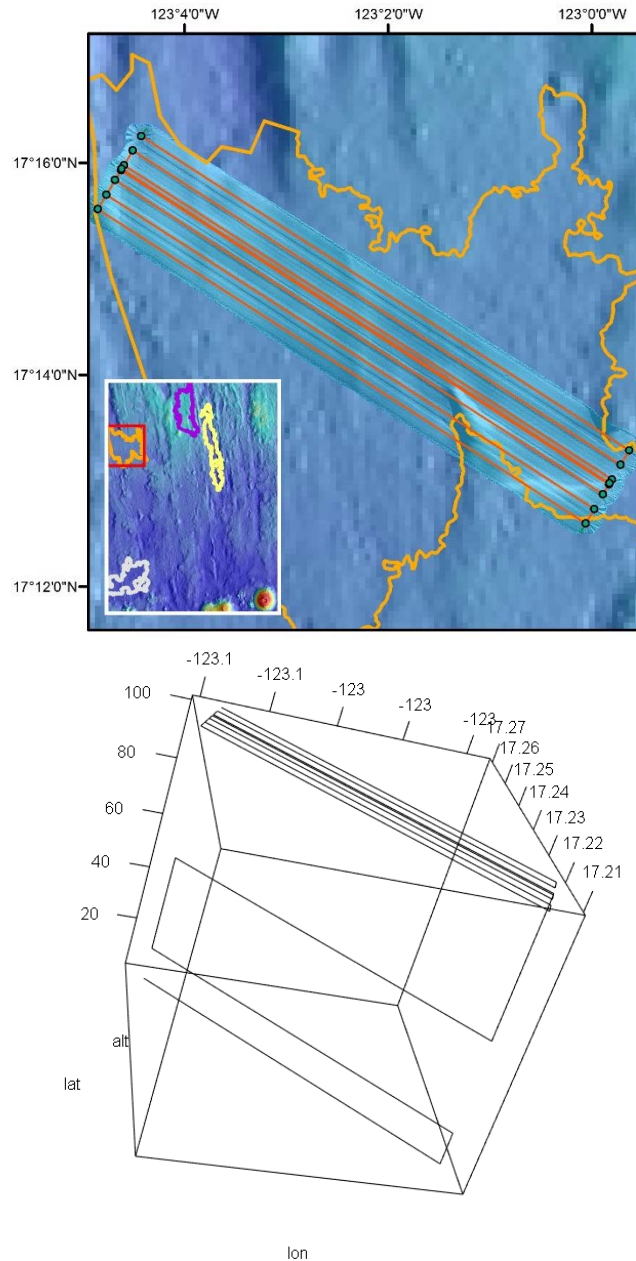

Figure 16. Diagram in 2 dimensions (top) and in 3 dimensions (bottom) of the planned route for Mission 78 within the Flat study area during JC120.

Mission 79

We designed this mission to carry out a multi-frequency assessment of the same 1.8km long area of seabed (for Tim LeBas). We collected Edgetech and EM2040 data at varying depths (100, 50, 40, and 15 meters altitude). The following data were collected:

- 100m altitude: EM2040 (200KHz)
 - 50m altitude: EM2040 (300KHz); Edgetech at low frequency
 - 40m altitude: EM2040 (400KHz); Edgetech at low frequency
 - 15m altitude: Edgetech at high frequency
 - 3m altitude: Photography and Edgetech at high frequency (offset from other lines by 25m)
- We also collected the first Autosub photographic dataset during JC120. This was composed by 40 transects of 1.8km each, taken at a targeted depth of 3m altitude.

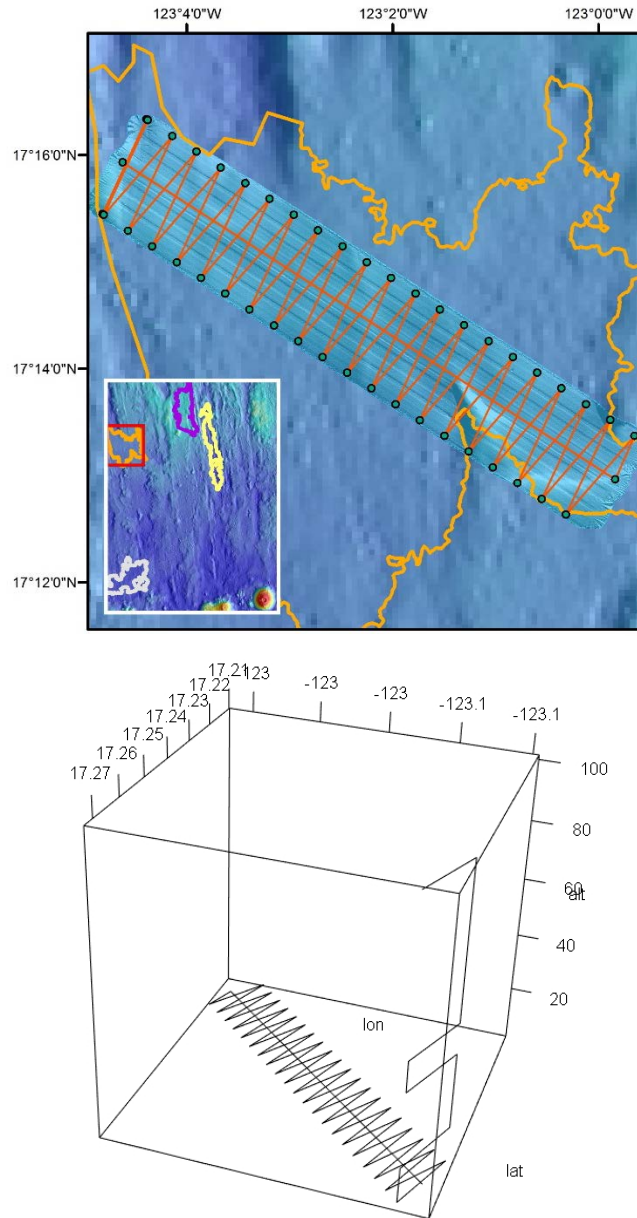

Figure 17. Diagram in 2 dimensions (top) and in 3 dimensions (bottom) of the planned route for Mission 79 within the Flat study area during JC120.

Mission 80

This mission was designed to collect EM2040 swath data at the ridge site and cover a small area of the trough site. All the swath was recorded at 100m altitude.

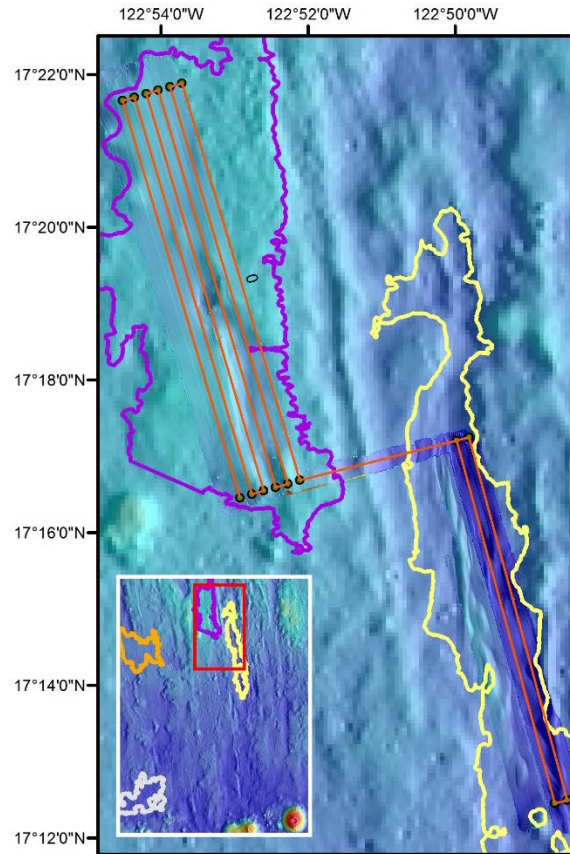

Figure 18. Diagram in 2 dimensions of the planned route for Mission 80 between the Ridge and the Trough study areas during JC120.

Mission 81

This mission was designed to collect EM2040 swath data at the Trough area at 100m altitude, to then dive to 3 meters to record a set of 40 x 1.8km photographic transects within the Ridge zone.

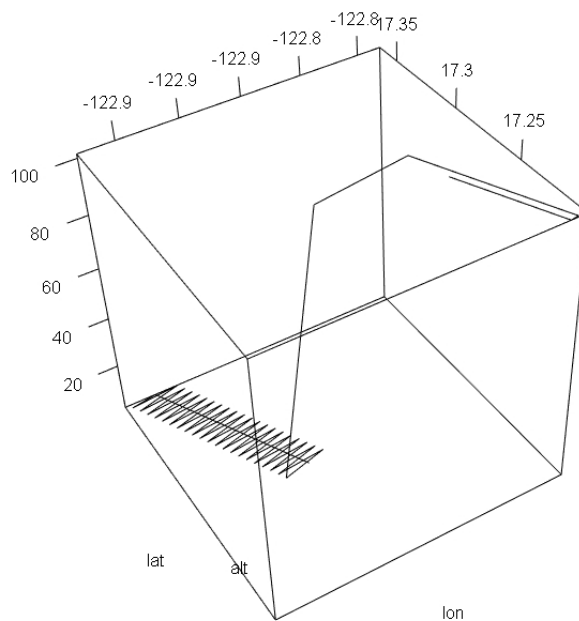
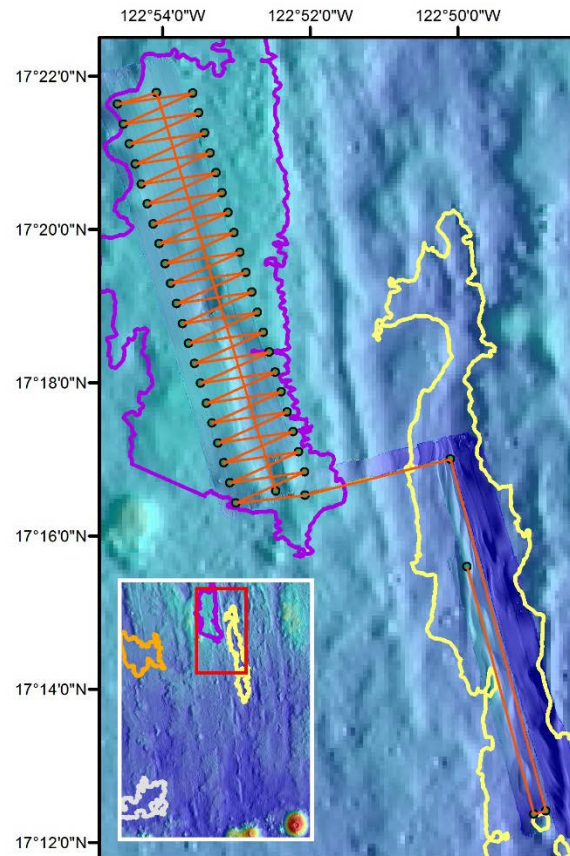

Figure 19. Diagram in 2 dimensions (top) and in 3 dimensions (bottom) of the planned route for Mission 81 between the Trough and the Ridge study areas during JC120.

Mission 83

This mission was devised to record sidescan data at 50m altitude along the central areas of the Ridge and the Trough zones. After this collection, we devised a set of 20 photographic transects (average length = 900m) along the prominent topographical features of the Trough zone. The potential area for camera transect allocation was very narrow in this area given the ant crash system of Autosub, that does not allow transects over slope gradients above 1:6 when flying at altitudes of 3m.

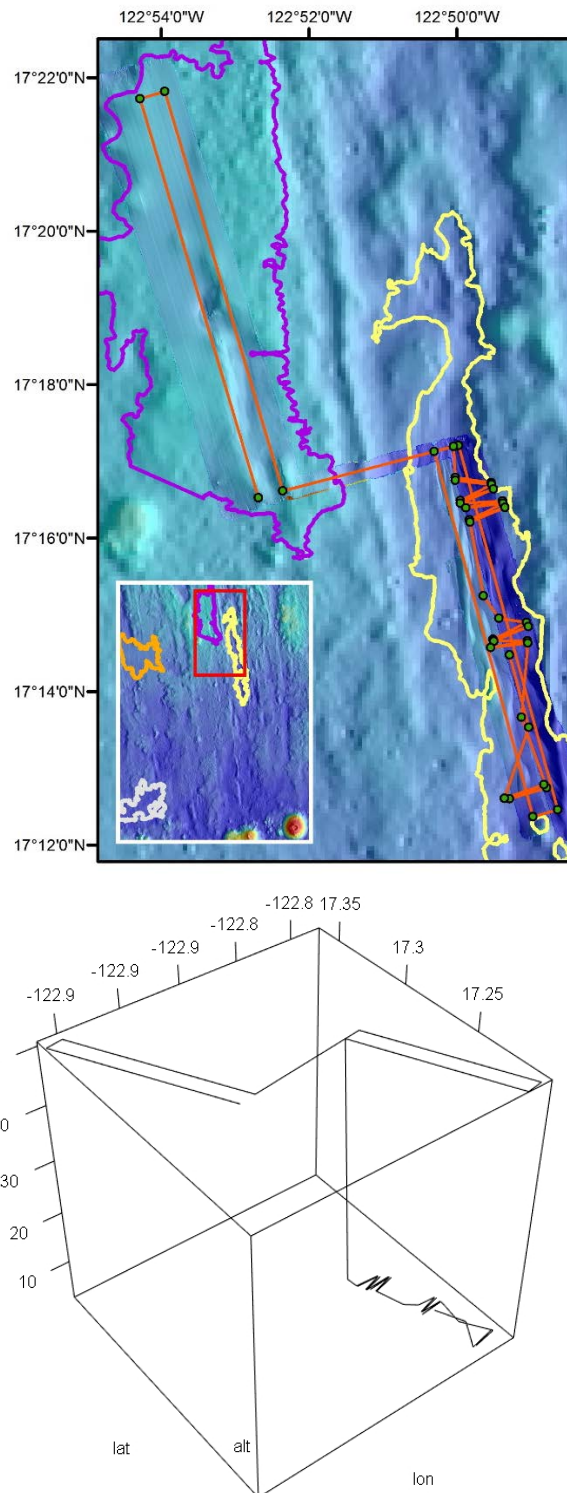

Figure 20. Diagram in 2 dimensions (top) and in 3 dimensions (bottom) of the planned route for Mission 83 between the Ridge and the Trough study areas during JC120.

| Station | Mission | Deployment | | | | Collection | | | |
|-----------|------------|------------|----------|---------------|----------------|------------|----------|----------------|----------------|
| | | UTC Date | UTC time | Latitude | Longitude | UTC Date | UTC time | Latitude | Longitude |
| JC120-043 | M78 | 29/04/2015 | 17:27:00 | 17° 16.559' N | 123° 4.397' W | 30/04/2015 | 21:52:00 | 17° 12.626' N | 123° 7.336' W |
| JC120-047 | M79 | 01/05/2015 | 18:45:00 | 17° 16.649' N | 123° 4.358' W | 02/05/2015 | 02:43:00 | 17° 16.2104' N | 123° 4.4604' W |
| JC120-057 | M80 | 03/05/2015 | 18:03:00 | 17° 16.8' N | 122° 52.6' W | 04/05/2015 | 22:47:00 | 17° 17.173' N | 122° 51.563' W |
| JC120-078 | M81 | 07/05/2015 | 15:18:00 | 17° 15.882' N | 122° 49.83' W | 08/05/2015 | 23:20:00 | 17° 16.571' N | 122° 52.596' W |
| JC120-087 | M83 | 10/05/2015 | 07:26:00 | 17° 16.81' N | 122° 52.555' W | 11/05/2015 | 14:35:00 | 16° 14.61' N | 122° 48.92' W |

Table 9. Summary table of coordinates and time of deployment and collection for each successful Autosub6000 mission. All positions WGS1984.

| | Total distance (km) | Mission duration (hh:mm:ss) | Data record (km) | | | | Num pictures | Usable pictures |
|------------|------------------------|--------------------------------|------------------|-------|----------|--------|--------------|-----------------|
| | | | Total length | Swath | Sidescan | Camera | | |
| M78 | 115.4 | 27:50:05 | 103.1 | 62.8 | 40.2 | | | |
| M79 | 113.7 | 27:24:49 | 84.9 | | 84.9 | 81.3 | 92184 | 83600 |
| M80 | 102.9 | 24:35:56 | 84.4 | 84.4 | | | | |
| M81 | 125.8 | 30:23:56 | 104.3 | 18 | 86.3 | 86.3 | 91075 | 84700 |
| M83 | 141.4 | 34:06:26 | 73.8 | 73.8 | 73.8 | 30.4 | 73175 | 29600 |

Table 10. Summary table of recorded data and mission spatial and temporal lengths for each successful Autosub6000 mission. Number of pictures described account for each of the two cameras used. Useful images are based on survey time between 2m and 4m altitude.

Amphipod Trap

Brian Bett

The amphipod trap used during RRS *James Cook* cruise 120 was of NOC deepseasgroup design and in its present form has been in use for c. 5-years, representing a development of the DEMAR trap used formerly (IOS / SOC). The seabed frame carries four separate double-parlour traps (see Figure 21), two located close to the seafloor and two about 1-metre above bottom. The trap was deployed on a simple mooring as follows:

- Ballasted seabed frame with four traps and acoustic release.
- 50m braid rope.
- Five yellow benthos spheres on 3m chain, swivel each end.
- 10m polyprop rope.
- Dan buoy of one benthos sphere carrying weighted mast with simple flag.
- 20m polyprop rope.
- Lazy float (one benthos sphere)

Two deployments were successfully completed during the present cruise:

| Station | Date, JDay, 2015 | Depth (m corr.) | Latitude | Longitude | Soak time |
|-----------|------------------|-----------------|-------------|--------------|------------|
| JC120-008 | 112-113 | 4300 | 16 53.454 N | 123 00.266 W | 22 hours |
| JC120-039 | 119-120 | 4230 | 17 19.258 N | 122 49.957 W | 39.5 hours |

In each case, all traps were baited with a section of tuna, approximating the weight of a large mackerel. On recovery the catch from each trap was preserved separately in c. 100% ethanol for return to NOC. A single fish caught in a bottom trap of Stn. JC120-008 was preserved separately in 10% formalin. In addition 10 baited hooks were also attached to the frame. Deployment JC120-008 did return a large rattail fish to the surface, apparently on a hook, however, it was lost as the trap was lifted from the water. The NHM team photographed a selection of specimens from the catches these were similarly preserved, individually labelled, and retained with the bulk catch samples. Station data were recorded for the moment of mooring deployment (ship's position, and sounding), soak time was estimated based on an assumed descent speed of 40m/min (i.e. equal to ascent speed) and recorded release time.

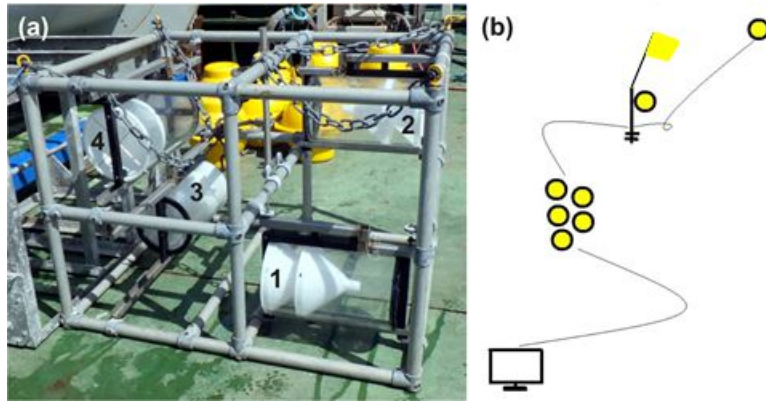

Figure 21. Amphipod trap. (a) Seabed frame showing locations of traps. (b) Mooring sketch for amphipod trap as deployed during RRS James Cook cruise 120.



Figure 22. Example specimens from amphipod trap deployment at Stn. JC120-008.



Figure 23. Example specimens from amphipod trap deployment at Stn. JC120-039.

Amphipod trap catches will be returned to Dr Tammy Horton (NOC) for community analysis, and morphologic and genetic taxonomic description.

Agassiz Trawl

Brian Bett

A NMFSS-supplied, modified 3m Agassiz trawl was employed during RRS *James Cook* cruise 120. In expectation of fishing ground with polymetallic nodules and concretions, the trawl frame was fitted with a robust trawl-mouth grill (Figure 24). Top and bottom bars were fitted to the trailing edge of the frame, and a series of 27 plates (1cm thick) welded vertically between them, giving 10cm horizontal apertures to the net mouth. The trawl was rigged with double weak-links, one on the towing bridles, one on the side recovery wire. A 500m pennant wire was used during all trawl deployments. In an attempt to avoid excess catches the trawl was fished at a minimal scope (c. 1.06). The trawl was deployed to c. 100mab with the ship holding station, the ship then began towing at 0.5 knots and wire was paid out at 10m/min. Bottom contact was detectable as a slight reduction in tension. Pay-out was continued until the c. 1.06 scope was achieved. Deployments were monitored with an NMFSS-supplied 2-second 10kHz pinger mounted on the wire at the outboard end of the trawl warp, i.e. 500m above the gear. Pinger traces were displayed on the ship's Simrad EK500 oceanographic echosounder, which performed well, a useful bottom echo was intermittently detectable, pinger-seabed separation was c. 300m during the fishing phase of each deployment. No attempt was made to quantify the seabed track length (or area fished) as the gear is very likely to have 'skipped' over the seafloor. Station data recorded was selected as time and net position of the centre of the fishing phase and a representative sounding for the tow.

| Station | Date, JDay, 2015 | Latitude | Longitude | Depth (m corr.) | Catch |
|-----------|------------------|------------|-------------|-----------------|---------------|
| JC120-031 | 117 | 16 55.88 N | 123 01.45 W | 4270 | Zero |
| JC120-037 | 118 | 17 15.08 N | 123 03.73 W | 4160 | c. 40 litres |
| JC120-104 | 135 | 13 30.42 N | 116 35.35 W | 4130 | c. 200 litres |

The first deployment (Stn. JC120-031) failed (zero catch) as a result of the codend (Shrimper's) knot being pushed off the net. For subsequent deployments (Stn.s JC120-037, 104) a sacrificial codend knot (multiple surgeon's knots), interlaced through the net was employed. Stn. JC120-037 produced a modest catch dominated by small (order 2cm) polymetallic nodules, a good number of artefacts (*Charcharodon megalodon* teeth, other shark's teeth, whale ear bones), and only a very modest catch of invertebrates (c. 5 specimens). Stn. JC120-104 recovered a much more substantial catch, dominated by larger (to >10cm maximum dimension, note largest nodules will have been excluded by net mouth grill) polymetallic nodules, a few artefacts, and a small catch of invertebrates (c. 20 specimens).



Figure 24. Modified 3m Agassiz trawl as deployed during RRS *James Cook* cruise 120. (Left) Modified frame in toto. (Right) Detail of the net mouth grill (horizontal aperture 10cm).

Coring

Andy Gates, Brian Bett, Claire Laguionie-Marchais and Jen Durden

The boxcorer, megacorer and gravity corer were used to sample seabed sediments during JC120.

Megacorer

The deepseas group Megacore (Bowers & Connelly design) was employed during RRS *James Cook* cruise 120. For all deployments it was fitted with eight 10cm internal diameter coring units and four extra lead ballast plates (in addition to its standard ballast load). Deployments were monitored with an NMFSS-supplied 1-second 10kHz pinger and an USBL beacon mounted on the wire 50m above the gear. Pinger traces were displayed on the ship's Simrad EK500 oceanographic echo-sounder, which generally performed well, although bottom echo detection was highly variable (likely on sea state and ship's thruster noise). The USBL system appeared to work well throughout. Station data were recorded for the moment of bottom contact: time (UTC), ship's position, estimated gear position (USBL), sounding, and metres of wire deployed.

The NOC-OBE Bowers & Connelly megacorer was used on 26 occasions during the cruise for collection of sediment for biology and geochemistry analysis (Table 11). At each of the Ridge, Flat and Trough strata one geochemistry and five replicate biology megacorer deployments were carried out. At Deep Plain there were three replicate biology megacorer deployments and one for geochemistry. A single megacorer deployment was carried out at the volcano in the south of the APEI survey area for geochemistry. Some material was available for environmental parameters used in biology analysis (grain size and lipids). At UK-1 two megacorer deployments were completed, one for geochemistry and one for biology. Eight cores were used on every drop. For geochemistry deployments three of the eight cores were drilled tubes for pore water oxygen sample collection.

The megacorer performed well in the survey of the APEI. On average 7/8 cores (mean) worked on each deployment in the APEI with 12 deployments retaining the maximum 8 samples. Sample length was generally good with penetration reaching 42 cm (mean across all core tubes 37 cm). The least successful deployment was at JC120-020 (Flat-3) where only four short samples were recovered. This may have been caused by swell lifting of the megacorer shortly after the initial contact with the seabed. A replacement drop (JC120-076) was completed later in the cruise in which seven cores of approximately 39 cm length were recovered. In some samples nodules were pushed down the side by the core tube. This was most notable in cores from UK-1 where the nodules were larger. At the Volcano site (JC120-090) the only 5 cores recovered and they were shorter, perhaps because of the sediment type.

| Strata | Location | Station | latitude | longitude | eDNA | Meiofauna DNA | Quantitative Meiofauna | Macrofauna DNA | Pigments | Lipids | Grain size | Nematodes | UALG | Geochem |
|------------|--------------|-----------|--------------|--------------|------|---------------|------------------------|----------------|----------|--------|------------|-----------|------|---------|
| Deep Plain | Deep Plain-1 | JC120-010 | 16° 54.769 | 122° 59.819 | | | | | | | | | | 6 |
| Deep Plain | Deep Plain-1 | JC120-012 | 16° 54.769 | 122° 59.819 | 1 | 1 | 1 | 2 | 1 | 1 | 1 | | | |
| Deep Plain | Deep_Plain_2 | JC120-092 | 16° 54.1431 | 123° 0.9724 | 1 | 1 | 1 | 1 | 1 | 1 | | 1 | | |
| Deep Plain | Deep_Plain_3 | JC120-084 | 16° 54.44 | 123° 1.504 | 1 | 1 | 1 | 1 | 1 | 1 | 1 | 1 | | 1 |
| Flat | Flat_3_1 | JC120-076 | 17° 15.04836 | 123° 1.76285 | 1 | 1 | 1 | 1 | | 1 | 1 | 1 | 1 | |
| Flat | Flat_5 | JC120-075 | 17° 14.3809 | 123° 1.59376 | 1 | 1 | 1 | | 1 | 1 | 1 | 1 | | 1 |
| Flat | Flat-1 | JC120-023 | 17° 14.4476 | 123° 3.9769 | 1 | 1 | 1 | 1 | 1 | 1 | 1 | | | 3 |
| Flat | Flat-1 | JC120-025 | 17° 14.4229 | 123° 3.9938 | | | | | | | | | | 7 |
| Flat | Flat-2 | JC120-019 | 17° 14.9352 | 123° 1.2778 | 1 | 1 | 1 | 1 | 1 | 1 | 1 | | | |
| Flat | Flat-3 | JC120-020 | 17° 15.031 | 123° 1.754 | 1 | 1 | | 1 | 1 | 1 | | | | |
| Flat | Flat-4 | JC120-024 | 17° 13.1865 | 123° 2.6707 | 1 | 1 | 1 | | 1 | 1 | 1 | | | |
| Ridge | Ridge_1 | JC120-048 | 17° 21.5579 | 122° 54.1743 | 1 | 1 | | | | | | | | 8 |
| Ridge | Ridge_1 | JC120-049 | 17° 21.5566 | 122° 54.173 | 1 | | 1 | 1 | 1 | 1 | 1 | 1 | 1 | |
| Ridge | Ridge_2 | JC120-058 | 17° 18.8441 | 122° 54.0525 | 1 | 1 | | 1 | 1 | 1 | 1 | 1 | | |
| Ridge | Ridge_3 | JC120-059 | 17° 22.0177 | 122° 53.9258 | 1 | | 1 | | 1 | 1 | 1 | | | |
| Ridge | Ridge_4 | JC120-065 | 17° 17.3004 | 122° 53.0735 | 1 | 1 | 1 | 1 | 1 | 1 | 1 | 1 | | 1 |
| Ridge | Ridge_5 | JC120-066 | 17° 19.685 | 122° 53.273 | 1 | 1 | 1 | 1 | 1 | 2 | 1 | 1 | | |
| Trough | Trough_1 | JC120-028 | 17° 13.0663 | 123° 49.3885 | 1 | 1 | 1 | | 1 | 1 | 1 | 1 | 1 | |
| Trough | Trough_1 | JC120-063 | 17° 13.0723 | 122° 49.3904 | 1 | 1 | | | | | | | | 8 |
| Trough | Trough_2 | JC120-034 | 17° 9.45121 | 122° 48.7756 | 1 | 1 | 1 | | 1 | 1 | 1 | | | |
| Trough | Trough_3 | JC120-062 | 17° 8.725 | 122° 48.518 | 1 | 1 | 1 | 2 | 1 | 1 | 1 | | | |
| Trough | Trough_4 | JC120-064 | 17° 13.86791 | 122° 48.898 | | | 1 | | 1 | 1 | 1 | | | |
| Trough | Trough_5 | JC120-067 | 17° 17.769 | 122° 50.128 | 1 | 1 | 1 | 1 | 1 | 1 | 1 | 1 | | |
| Volcano | Volcano | JC120-090 | 16° 52.37487 | 122° 41.9143 | 1 | | | 1 | | 1 | 1 | | | 5 |
| UK-1 | UK-1 | JC120-105 | 13° 27.7888 | 116° 36.4874 | 1 | | | | | | 1 | | | 6 |
| UK-1 | UK-1 | JC120-106 | 13° 27.8125 | 116° 34.4962 | 1 | 1 | | 1 | 1 | 1 | | | | |

Table 11. Megacorer deployments during JC120

Initial observations

Megacorer samples were routinely photographed on recovery to deck. Examples are shown from the four strata of the APEI survey in Figure 25 to Figure 28 and the Volcano and UK-1 sample areas in Figure 29 and Figure 31. In the APEI the core profiles were generally a fine mud, consistent in colour with no notable layers but there were occasional white inclusions at various depths within the cores. With the exception of most of the samples at the Trough strata, nodules were often found on the surface of the cores (Figure 31). Nodules were occasionally forced down the side of the core (Figure 25, Core V) during operation at the seabed. On some occasions the top water was slightly turbid: not crystal clear as may be expected from previous megacorer experience. Some disturbance in the upper 1-2 cm of the cores may have been the result of bioturbation or perhaps disturbance as the corer

landed. There are notes in the biological rough log. There were occasionally cracks in the cores which were also documented in the biological rough log. This may have resulted from the movement of nodules on the sediment surface during corer operation at the seabed. Despite this the samples were deemed of sufficient quality for all analyses and none were rejected for this reason. At the Volcano station the appearance of the core samples was quite distinct from elsewhere. There were three layers of differing colour. The surface sediment was much paler in colour than the APEI sites and there was distinct darker layer below this (Figure 29). The grain size in the paler coloured sediment samples from Volcano was much coarser than elsewhere and examination of the sediment under a stereomicroscope showed it comprised the remains of pelagic foraminifera with little non-biogenic material. At UK-1 the nodules were much larger than other study sites and in some cases were pushed down in the core and all sediment had risen above it, so sediment in cores was very mixed.

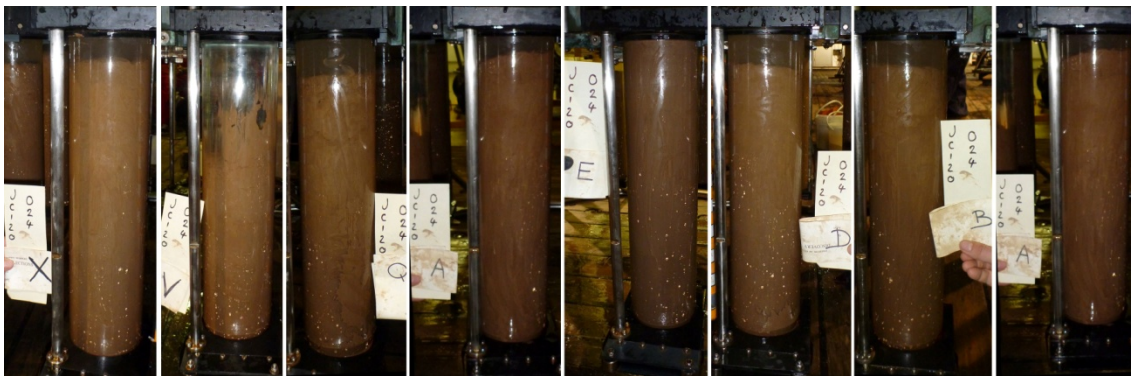

Figure 25. Megacore profiles from the Flat site (station JC120-024, Flat-4)

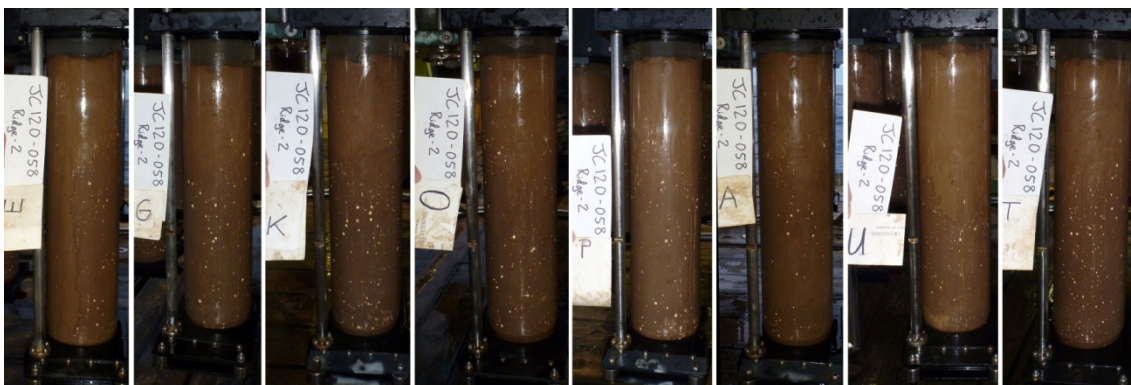

Figure 26. Example megacore profiles from the Ridge site (station JC120-058, Ridge-2)

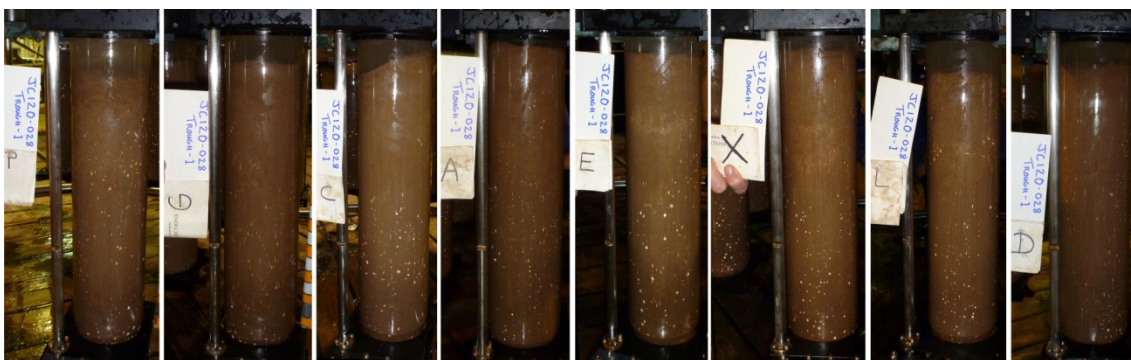

Figure 27. Example megacore profiles from the Trough site (station JC120-028, Trough-1)

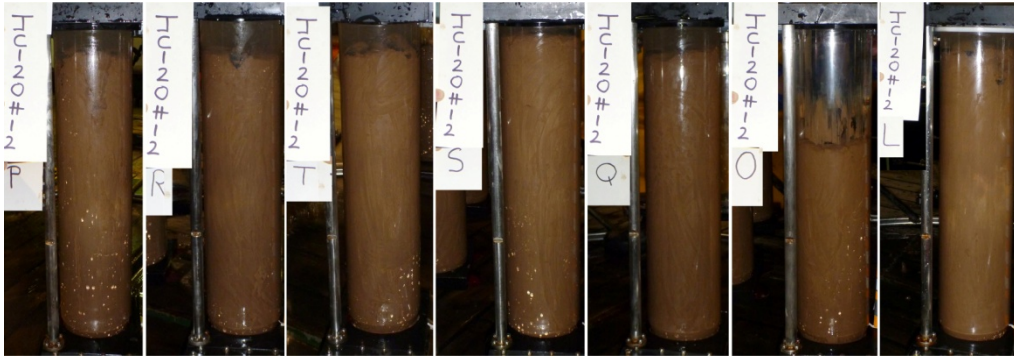

Figure 28. Example megacore profiles from the Trough site (station JC120-012, Deep Plain-1)

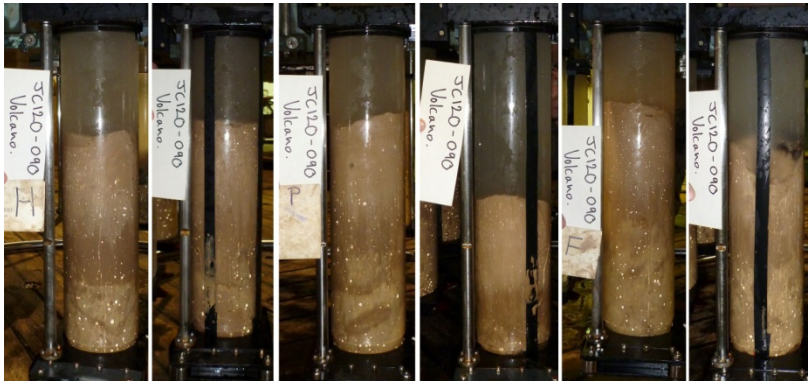

Figure 29. Example megacore profiles from the Volcano site (station JC120-058, Volcano)



Figure 30. Example megacore profiles from the UK-1 site (station JC120-105, UK-1)



Figure 31. Example megacore sample surfaces from high (left, Deep Plain 1) and low (right Trough-1) nodule density

Biology sample processing

On deck- Once megacorer was recovered to deck the cores were examined for overlying water clarity, presence of surface nodules, disturbance and cracks in the core and notable layers or patches in the sediment. They length of core sediment retention was measured and the core profiles photographed. They were then removed from the megacorer and transported as quickly as possible to the controlled temperature laboratory. The cores were allocated to the appropriate (future) analysis. Wherever possible samples were allocated randomly on the basis of sample priority but in some cases application of selection criteria was necessary. For example in the case of a full sample requiring multiple sections short cores were rejected in favour of longer samples and cores in which nodules had been forced down the side of the unit were rejected in the case of samples requiring very fine slicing. Once in the laboratory the core surfaces were photographed and the following processing carried out.

Lab processing:

Once in the controlled temperature laboratory cores were processed by two teams of two with assistance from others if available. One person held the core in position while the other sliced. Once the surface water had been collected or discarded a photograph was taken of the sample surface. When nodules were encountered on core surfaces, within the cores or when core surfaces were not level the protocol summarised by the diagram in Figure 32 was employed.

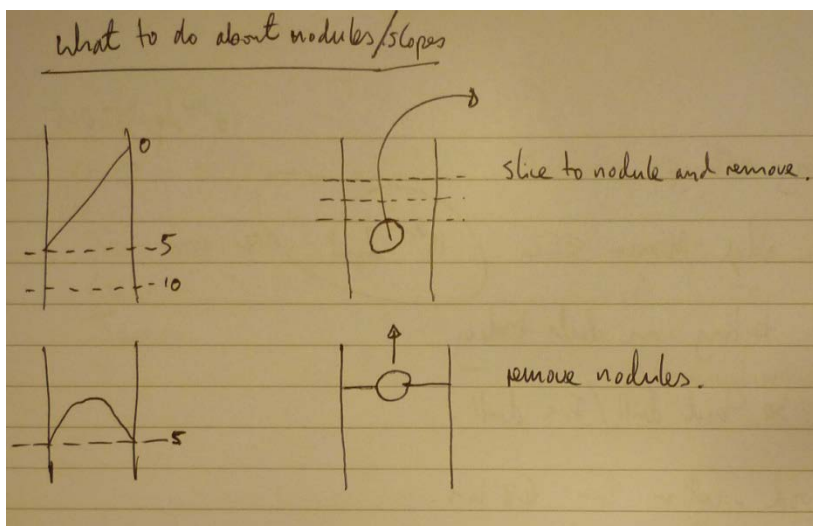

Figure 32. How to deal with nodules and slopes on the surface of the sediment in core processing

Details of slicing procedures to acquire the necessary sediment horizons are detailed in

Table 12. Samples retained from biological megacore processing and summarised below.

Grain size: The top water was discarded. From the sediment surface 0.5 cm slices were taken down to 2 cm, a 1 cm slice was then taken to 3 cm, followed by a 2 cm slice to 5 cm and then three 5 cm slices were taken to 20 cm as follows: 0-0.5 cm, 0.5-1 cm, 1-1.5 cm, 1.5-2 cm, 2-3 cm, 3-5 cm, 5-10 cm, 10-15 cm and 15-20 cm. The horizons were placed in labelled sealable plastic bags, contained within a single larger bag for each sample and stored in the fridge for transport back to Southampton. Slicing equipment was washed with filtered seawater before slicing and between slices.

eDNA

eDNA cores were sliced at 1 cm intervals to 10 cm below which 2 cm slices were taken as far as possible down to 34 cm. Material in contact with the side of the core was removed and small subsamples of the interior of the cores were removed using a spatula and retained in sterile vials or small sterile plastic bags. They were then frozen at -80°C (Freezer in hold). All slicing equipment was washed in 80% ethanol prior to sample processing and between each slice and gloves were worn at all stages. Nodules found on the surface were added to the meiofaunal DNA sample (below). Other nodules within the sediment were dried and weighed. Some nodules were frozen for microbial analysis (see eDNA section). eDNA samples were also collected from most geochemistry megacorer deployments.

Meiofaunal DNA: The remainder of 0-1 cm section of the eDNA cores and the overlying 3 cm of water were retained for meiofaunal DNA analysis along with the top 3 cm of overlying water. Once the slice was processed the sample was placed in cold filtered seawater, sieved over 300 and 150 µm mesh and stored in the fridge (4°C) until it was examined under a stereomicroscope for foraminifera. Any live specimens encountered were then preserved in RNA Later for DNA analysis and then frozen at -20 in a Freezer in the ship's hold. Nodules from this sample were examined for foraminifera. Specimens found were preserved in RNA Later and frozen. Once examined the nodules were dried, measured and weighed then retained in labelled plastic bags.

Lipids: The top water was discarded. Before slicing and between slices the equipment was rinsed with milliQ water. Four sections were taken at 0.5 cm horizons to 2 cm. Sediment in contact with the core tube was removed using a knife rinsed in MilliQ water and the remaining material preserved in muffled foil held inside labelled petri dishes, placed inside a single bag per sample and frozen at -80. When nodules were found in the sediments there were rinsed into the corresponding petri dish and placed in muffled foil and frozen in the same manner as the main sample. Gloves were worn at all stages of processing lipids samples.

Pigments: The top water was discarded. Before slicing and between slices the equipment was rinsed with milliQ water. Four sections were taken at 0.5 cm horizons to 2 cm. Sediment in contact with the core tube was removed with a knife washed in MilliQ water and the remaining material preserved in muffled foil held inside labelled petri dishes and frozen at -80. When nodules were found in the sediments they were rinsed into the corresponding petri dish and then dried and weighed and preserved in plastic bags, placed within a single bag per core. Some were also frozen, this is documented in the main sample list. Gloves were worn at all stages of processing lipids samples.

Quantitative meiofauna: Before processing and between slices the sampling equipment was washed with filtered seawater. 1 cm of top water was added to the 0-0.5 cm sample then quantitative meiofaunal samples were sliced at 0.5 cm intervals to 2 cm, at 1 cm intervals from 2-6 cm and then 2 cm intervals to 10 cm. The sediment and nodules from these samples were preserved in 10% formalin buffered with borax (5 g l⁻¹) and stored in Grey Crate 06 for transit back to Southampton. Slicing equipment was washed in filtered seawater.

Macrofaunal cold chain "live sort": Megacorer samples were used to collect macrofaunal specimens. This was non-quantitative and to supplement the specimens collected in the box corer samples (see box corer section). The aim of the megacorer macrofauna sampling was to attain high quality specimens rather than quantity. Megacores for macrofauna analysis were only processed when time was available for the cold chain processing. Megacore macrofaunal samples were sliced to 0-5

and 5-10 cm depth horizons and all the overlying water siphoned into the 0-5 cm sample. These were then sieved in cold filtered seawater and examined in cold water under a stereomicroscope. All megacore macrofaunal specimens were photographed and logged in the NHM dataset and then preserved in 90% ethanol and frozen at -20°C. Nodules were examined for epifauna before they were dried and weighed.

University of Algarve Toxicity: A core sample was retained from three contrasting sites for assessment of the toxicity of deep-sea sediments in the APEI (Flat, Ridge and Trough). Top water was discarded and then cores were sliced at 3 cm intervals: 0-3 cm, 3-6 cm, 6-9 cm and 9-12 cm. Sediment from the interior of cores was used. Material that had contacted the core tube was removed with a MilliQ washed knife. The material was placed in muffled aluminium foil inside a labelled plastic sample bag and frozen at -20°C in Freezer 3 in the ship's hold. Slicing equipment washed in filtered seawater and the top water discarded. Gloves were worn at all stages of processing lipids samples.

Nematodes: Samples for metazoan meiofauna were distinguished from the quantitative meiofauna samples by labelling them as "nematodes". Samples were low priority and were collected when spare material was available. The top three cm of sediment were retained in 1.5 l plastic bottles and preserved in 10% formalin buffered with borax (5 g l⁻¹) and stored in Grey Crate 06. Sampling equipment was washed in filtered seawater and 1 cm of top water was added to the sample. Nodules were rinsed, dried and stored.

Geochemistry: Megacorer deployments for geochemistry samples included three core tubes with holes drilled at 1 cm intervals vertically on four sides of the tube. These were placed on three separate sides of the megacorer. The lines of holes were taped prior to assembly of the megacorer. Tape must be applied as thinly as possible because it may interfere with the megacorer operation. The application of tape makes it difficult to remove the rings on the megacore tubes. Care must be taken not to tear the tape on removal of the rings. On most occasions eDNA samples were also taken from Geochemistry megacores. Further consideration of geochemistry samples is given elsewhere in this report.

Labelling

All samples were labelled with Cruise ID, Station number, Date (Julian Day), core letter, analysis type and type of preservative. The outside of every container was labelled and a paper label was placed inside the container.

| | eDNA | Meiofaunal DNA | Macrofauna DNA | Grain size | Quantitative meiofauna | Lipids | Pigments | Nematodes | UALG |
|------------------------|----------|----------------|----------------|------------|------------------------|------------|----------|-----------|-------|
| Surface Nodules | Meio DNA | dried | dried | dried | In sample | frozen -80 | dried+ | dried | dried |
| Horizons retained (cm) | 0-1 | 0-1 | 0-5 | 0-0.5 | 0-0.5 | 0-0.5 | 0-0.5 | 0-3 | 0-3 |
| | | | | 0.5-1 | 0.5-1 | 0.5-1 | 0.5-1 | | |
| | 1-2 | 1-1.5 | | 1-1.5 | 1-1.5 | 1-1.5 | | | |
| | | 1.5-2 | | 1.5-2 | 1.5-2 | 1.5-2 | | | |
| | 2-3 | 2-3 | | | | | | | |
| | 3-4 | 3-5 | | 3-4 | | | 3-6 | | |
| | 4-5 | 4-5 | | | | | | | |
| | 5-6 | 5-10 | 5-10 | 5-6 | | | | | |
| | 6-7 | | | 6-8 | | | | | |
| | 7-8 | | | 8-10 | | | | | |
| | 8-9 | | | | | | | | |
| | 9-10 | | | | | | 9-12 | | |
| | 10-12 | | 10-15 | | | | | | |
| | 12-14 | | | | | | | | |
| | 14-16 | | | | | | | | |
| | 16-18 | | | 15-20 | | | | | |
| | 18-20 | | | | | | | | |
| | 20-22 | | | | | | | | |
| | 22-24 | | | | | | | | |
| | 24-26 | | | | | | | | |
| 26-28 | | | | | | | | | |
| 28-30 | | | | | | | | | |
| 32-32 | | | | | | | | | |
| 32-34 | | | | | | | | | |

* the same sample as eDNA
+ some also frozen -80

Table 12. Samples retained from biological megacore processing

Box Coring

A NMFSS-supplied box core (USNEL-type design, 50x50cm square box) was employed during RRS *James Cook* cruise 120. Deployments were monitored by pinger and USBL beacon as per Megacore operations. It was rigged and operated as normal, penetration limiters were fitted to the column for the first five deployments (Stn. JC120-013 to 022) and removed for all remaining deployments (Stn. JC120-029 to 083). With the penetration limiters fitted, cores were of essentially uniform length (22-25cm). With the penetration limiters removed, cores were generally 40+cm in length, with notable exceptions at Stn. JC120-056 (29cm) and Stn. JC120-077 (33cm), and to a lesser extent at Stn. JC120-055 (38cm). Station data were recorded for the moment of bottom contact: time (UTC), ship's position, estimated gear position (USBL), sounding, and metres of wire deployed.

Boxcores were used primarily to sample the macrofauna. Once on deck and secured safely the surface water was immediately drained using a siphon and retained for analysis (there were some issues with top water draining) before samples were processed. Full details of sample processing are provided elsewhere in this report. Once the box was removed the sample was assessed visually, penetration measured and the surface and profiles were photographed.

Surface nodules were removed with forceps and counted and placed in cold filtered seawater to be examined for epifauna. The top 0-2 cm of sediment was then removed with trowels and immediately placed in cold filtered seawater and taken to the controlled temperature laboratory, sieved to 300 μm and sorted by the NHM macrofaunal ecologists. All specimens encountered in the "live sort" were preserved in vials of 90% ethanol and frozen at -20° Freezer 3. The residues from the live sort were preserved in 10% formalin buffered with borax (5 g l^{-1}) (Table 14) and stored in Grey Crate 06 in the hanger. The 2-5 cm section was removed with trowels and sieved with ambient seawater over 300 μm sieves on the sieving table on the back deck. A two-stage sieving procedure was employed. One person carefully broke up the sediment by gently agitating it in water ("washing machine technique") then the sediment was put in the sieve and sieved by the second team member.

The 2-5 cm samples were preserved in 10% formalin buffered with borax (5 g l^{-1}).

Nodules were dried, counted, measured (length, width and height) and weighed. In some cases nodules were preserved with the rest of the sample in formalin. These are detailed in Table 15.

| Date (JD) | Station | Area | Latitude (N) | Longitude (W) | Depth (m) | Penetration Limiter? |
|-----------|-----------|--------------|--------------|---------------|-----------|----------------------|
| 15114 | JC120-013 | Deep Plain-1 | 16° 54.765 | 122° 59.84 | 4297 | On |
| 15129 | JC120-082 | Deep Plain-2 | 16° 54.145 | 123° 0.9744 | 4320 | Off |
| 15129 | JC120-083 | Deep Plain-3 | 16° 54.399 | 123° 1.387 | 4265 | Off |
| 15114 | JC120-015 | Flat-1 | 17° 14.448 | 123° 3.978 | 4156 | On |
| 15115 | JC120-022 | Flat-2 | 17° 14.934 | 123° 1.282 | 4161 | On |
| 15115 | JC120-021 | Flat-3 | 17° 15.03 | 123° 1.754 | 4180 | On |
| 15126 | JC120-072 | Flat-4 | 17° 13.198 | 123° 2.668 | 4179 | Off |
| 15126 | JC120-073 | Flat-5 | 17° 14.381 | 123° 1.584 | 4162 | Off |
| 15114 | JC120-014 | Ridge-1 | 17° 21.561 | 122° 54.185 | 4021 | On |
| 15122 | JC120-050 | Ridge-2 | 17° 18.851 | 122° 54.053 | 4045 | Off |
| 15123 | JC120-055 | Ridge-3 | 17° 22.002 | 122° 53.972 | 4029 | Off |
| 15123 | JC120-056 | Ridge-4 | 17° 17.31 | 122° 53.068 | 4015 | Off |
| 15127 | JC120-077 | Ridge-5 | 17° 19.672 | 122° 53.271 | 4012 | Off |
| 15117 | JC120-029 | Trough-1 | 17° 13.069 | 122° 49.387 | 4240 | Off |
| 15124 | JC120-060 | Trough-2 | 17° 9.456 | 122° 48.774 | 4288 | Off |
| 15124 | JC120-061 | Trough-3 | 17° 8.728 | 122° 48.495 | 4280 | Off |
| 15126 | JC120-069 | Trough-4 | 17° 13.869 | 122° 48.9 | 4264 | Off |
| 15126 | JC120-070 | Trough-5 | 17° 17.774 | 122° 50.128 | 4231 | Off |
| 15135 | JC120-107 | UK-1 | 13° 27.814 | 116° 36.496 | 4110 | Off |

Table 13. Boxcorer sampling stations

| Station | Area | Macrofauna DNA | Sample 0-2 cm | Sample 2-5 cm | Nodules 0-2 | macrofauna 0-2 cm |
|-----------|--------------|----------------|---------------|---------------|------------------|-------------------|
| JC120-013 | Deep Plain-1 | Ethanol frozen | Formalin | Formalin | Formalin & Dried | Formalin |
| JC120-082 | Deep Plain-2 | Ethanol frozen | Formalin | Formalin | Dried | Dried |
| JC120-083 | Deep Plain-3 | Ethanol frozen | Formalin | Formalin | Dried | Formalin |
| JC120-015 | Flat-1 | Ethanol frozen | Formalin | Formalin | Formalin & Dried | Formalin |
| JC120-022 | Flat-2 | Ethanol frozen | * | Formalin | Dried | Dried |
| JC120-021 | Flat-3 | Ethanol frozen | * | Formalin | Dried | Formalin |
| JC120-072 | Flat-4 | Ethanol frozen | Formalin | Formalin | Dried | Formalin |
| JC120-073 | Flat-5 | Ethanol frozen | Formalin | Formalin | Dried | |
| JC120-014 | Ridge-1 | Ethanol frozen | Formalin | Formalin | Dried | |
| JC120-050 | Ridge-2 | Ethanol frozen | Formalin | Formalin | Dried | Dried |
| JC120-055 | Ridge-3 | Ethanol frozen | Formalin | Formalin | Formalin & Dried | |
| JC120-056 | Ridge-4 | Ethanol frozen | Formalin | Formalin | Dried | Formalin |
| JC120-077 | Ridge-5 | Ethanol frozen | Formalin | Formalin | Formalin & Dried | Dried |
| JC120-029 | Trough-1 | Ethanol frozen | * | Formalin | Dried | |
| JC120-060 | Trough-2 | Ethanol frozen | Formalin | Formalin | | |
| JC120-061 | Trough-3 | Ethanol frozen | Formalin | Formalin | Dried | Dried |
| JC120-069 | Trough-4 | Ethanol frozen | Formalin | Formalin | Dried | Dried |
| JC120-070 | Trough-5 | Ethanol frozen | Formalin | Formalin | Dried | Dried |
| JC120-107 | UK-1 | Ethanol frozen | | | | |

*residues were not retained after live sort

Table 14. Samples retained from the box corer

Initial observations

Nodule abundance on the surface of the box core samples seemed variable. Example surface images are shown in Figure 33. Most nodules were noted in Deep Plain-1. At the Trough strata sites nodule density was lowest. Nodule size also varied. In the APEI they were generally small but at UK-1 they were large, and brittle. Initial data from on board box corer nodule counts and measurements are shown in Table 15.

The sediment in the samples was somewhat variable in consistency. This was most notable in JC120-056 where the deeper clay was drier and firmer than other samples. This information is not visible in sample photographs. The box core sediment profiles were generally consistent brown in colour with no notable layers or changes apart from those mentioned above (Figure 34 a). Occasionally samples demonstrated white inclusions (Figure 34 b) similar to the megacore samples). Nodules from the UK-1 site were notably larger but may have affected the operation of the sampling device because the surface was not flat on recovery to deck.

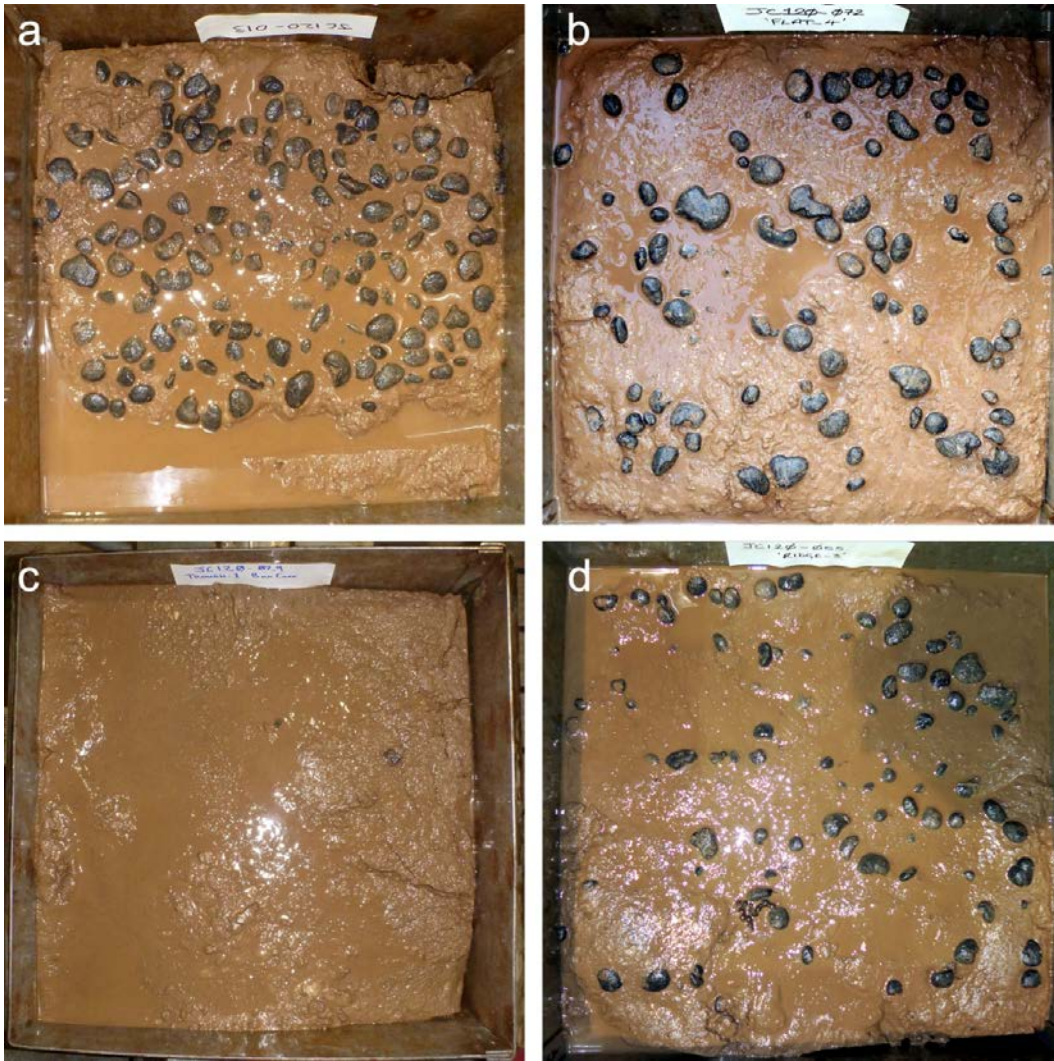

Figure 33. Example box core surfaces from the four APEI strata (a – Deep Plain, b – Flat, c – Trough and d - Ridge)

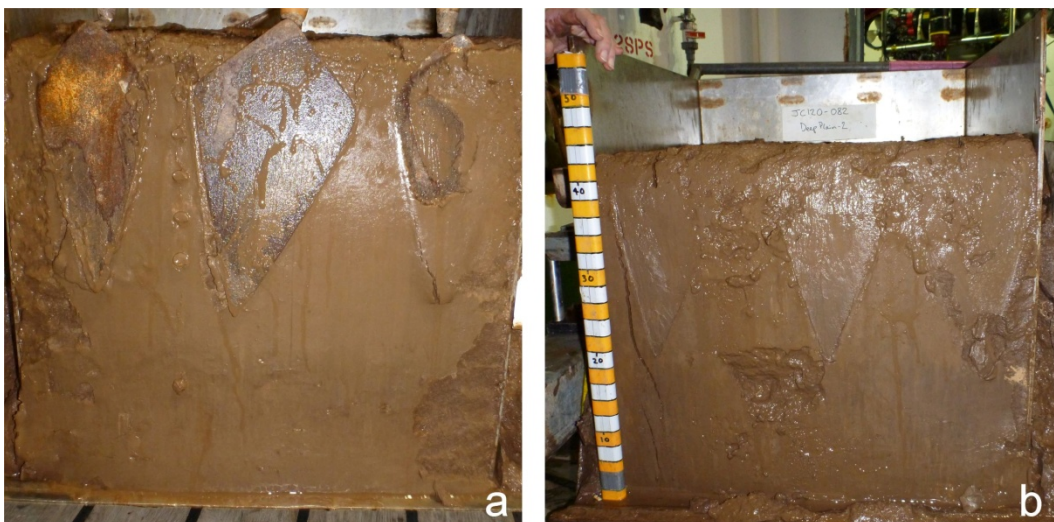

Figure 34. Example box core profiles from the APEI strata, a) Trough & b) Deep Plain with white inclusion (right of image).

| | Total | | Max.diameter (mm) | Min diameter (mm) | Thick (mm) | Mass (g) | | | |
|-----------------|--------------|--------|--------------------------|--------------------------|-------------------|------------------------|---------------------|-----------------------|------------|
| All nodules | 1424 | Mean | 20.02 | 15.71 | 9.32 | 4.33 | | | |
| | | Median | 19 | 15 | 9 | 3 | | | |
| Surface (0-2cm) | 1404 | Mean | 20.13 | 15.68 | 9.31 | 4.35 | | | |
| | | Median | 20 | 15 | 9 | 3 | | | |
| | | | | | | | | | |
| Surface | Total | | Max.diameter (mm) | Min diameter (mm) | Thick (mm) | Total mass (kg) | No. Boxcores | Nodule density | |
| Deep Plain | 475 | Mean | 21.36 | 15.59 | 8.44 | 1.9204 | 3 | 633.33 | nodules/m2 |
| | | Median | 21 | 15 | 8 | | | 2.56 | kg/m2 |
| Flat | 384 | Mean | 21.95 | 18.55 | 11.37 | 2.34145 | 5 | 307.2 | nodules/m2 |
| | | Median | 21 | 18 | 11 | | | 1.87 | kg/m2 |
| Ridge | 307 | Mean | 17.98 | 13.92 | 8.89 | 1.0536 | 5 | 245.6 | nodules/m2 |
| | | Median | 17 | 14 | 9 | | | 0.84 | kg/m2 |
| Trough | 246 | Mean | 16.16 | 12.55 | 7.82 | 0.6808 | 4 | 246 | nodules/m2 |
| | | Median | 15 | 11 | 7 | | | 0.68 | kg/m2 |

Table 15. Summary data for nodule measurements made onboard

Macrofaunal Genetics

James Bell & Sergio Taboada Moreno – Natural History Museum, London

Aims & General Summary of Work completed



Figure 35. Selection of images of specimens from APEI 4

The Natural History Museum (NHM) component of JC120 aimed to collect, live sort, photograph and preserve individual specimens to be used for combined molecular and taxonomic analyses, in conjunction with faunal material collected from other areas of the Clarion-Clipperton Zone (see ‘Abyssline’ Project – NHM & University of Hawaii).

We collected 595 macrofaunal specimens (300µm) from a variety of gear (Table 16) deployed in the APEI and UK1 claim areas. Material was sieved and sorted according to the ‘Cold Chain Method’ used in the Abyssline project and recommended by the ISA. Sieved material and nodules were live sorted, and organisms were photographed and preserved in molecular grade ethanol (80-95%) or

RNA later for subsequent sequencing at the NHM (to be completed by S Taboada and other members of the MIDAS project).

| Area | Site | Gear | N Deployments | N Specimens collected |
|--------------------|--------------|---------------|---------------|-----------------------|
| APEI 4 | Deep Plain | Megacore | 4 | 11 |
| | | Boxcore | 3 | 71 |
| | | Amphipod Trap | 1 | 14 |
| | Ridge | Megacore | 4 | 16 |
| | | Boxcore | 5 | 161 |
| | Flat | Megacore | 3 | 12 |
| | | Boxcore | 5 | 103 |
| | | Trawl | 1 | 32 |
| | Trough | Megacore | 4 | 8 |
| | | Boxcore | 5 | 71 |
| | Volcano | Megacore | 1 | 8 |
| Other | <i>HyBIS</i> | 2 | 24 | |
| UK1 | 'UK1 Claim' | Megacore | 1 | 1 |
| | | Boxcore | 1 | 11 |
| | | Trawl | 1 | 40 |
| Totals | | Boxcore | 19 | 419 |
| | | Megacore | 22 | 66 |
| | | Trawl | 2 | 72 |
| | | <i>HyBIS</i> | 2 | 24 |
| | | Amphipod trap | 1 | 14 |
| Grand Total | | All | 46 | 595 |

Table 16. Number of deployments and specimens collected per site surveyed during JC120 (maps and coordinates of sites surveyed are given elsewhere)

Methods

Cold Chain Processing

The cold chain method is essential to preserving high quality individual specimens to be used for molecular analyses. To this end, we set up a system of pumps and cold-water reservoirs (Figure 36) that kept specimens cold (target temperature of 2°C) whilst they were being sieved and sorted. Our methods were consistent with those used in the 'Abyssline' Project (Adrian Glover, Thomas Dahlgren, Craig Smith, Helena Wiklund et al.).

On-demand cold, filtered seawater (CFSW) was supplied via a submersible pump from four reservoirs (each 100L) that were kept in the controlled temperature laboratory (CT lab) on board. These reservoirs were filled from the ship's seawater pump system, through a filter and water was allowed a minimum of 6 hours to acclimate to a target temperature of 2–4°C before use.

The equipment used was as follows:

Filter (10" Big Blue Filter Housing with 4.5" X 10" Pleated filter 5 micron – Supplier www.healthy-house.co.uk). This required brass connectors (15mm & 22mm) to attach to the garden hose – via standard Hozelock screw tap fittings

Submersible pump (New Jet NJ2400 Aquarium Pump – Supplier <http://www.marineaquatics.co.uk>)

A garden hose with standard Hozelock snap connectors was used to transfer water from the seawater tap to the filter and onwards to the reservoirs.

Flexi Tubing (12mm ID - 16mm OD – supplier as submersible pump) was used to transfer water from the reservoirs via the submersible pump.

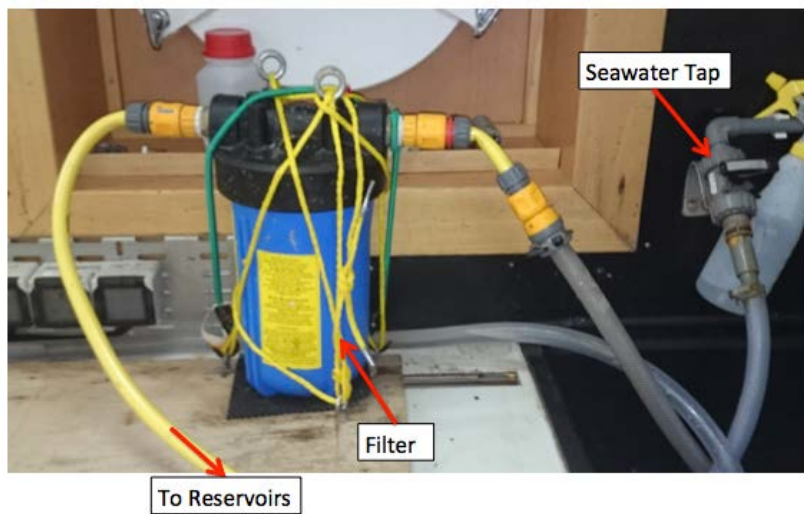
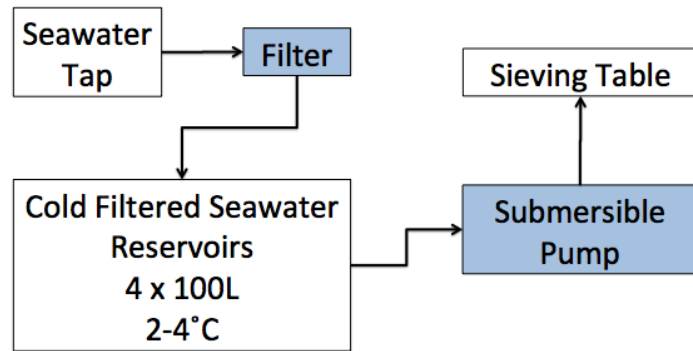

Figure 36. Cold Room set up. Top: Schematic diagram of the cold room. Middle: Filter connected to seawater tap providing filtered seawater to the reservoirs. Bottom: Reservoirs of filtered seawater with the submersible pump providing cold filtered seawater to the sieving table

Processing procedure varied slightly, depending on gear but in principle the aim was always to minimise the increase in temperature for the specimens by removing them quickly into cold storage. In addition to the planned sample programme, we also took opportunistic samples from trawls, amphipod traps and *HyBIS* deployments. In these cases, the procedure was to get specimens into CSFW as soon as possible.

Once in cold storage (sieved and in CSFW in a laboratory fridge) all samples were processed and preserved (usually in 80 % ethanol) within a maximum of 24 h following collection.

Megacore processing procedure

1. Measure and photograph cores once megacorer on deck
2. Remove cores as soon as possible and store in the CT lab
 - a. There were several different objectives to be met by the megacoring programme (*e.g.*, lipid and pigments content, quantitative meiofauna, eDNA) and the number of cores available to the NHM depended upon the number of cores successfully recovered. Between 0 and 2 cores per deployment were used by the NHM
3. Drain core top water into a bucket
4. Photograph top of core and remove nodules with large tweezers into topwater bucket
5. Take two slices (0–5 and 5–10 cm) separately and place in CSFW, and discard the rest of sediment
6. Sieve each slice under CSFW with a 300µm sieve
7. Store residues and nodules in fridge in wet lab to await sorting

Boxcore processing procedure

1. Measure temperature of topwater once the core secured on deck
2. Drain topwater into a bucket
3. Remove box and secure away from winch area
4. Photograph top of core
5. Remove nodules with large tweezers and place into bucket(s) of CSFW
6. Remove side of box and photograph and measure the sediment retained in the box
7. Remove entire 0-2 cm slice and place into buckets of CSFW
 - a. 2–5 cm slice was sieved and preserved in 10% formalin, to be kept in the Discovery Collections at NOC, Southampton. When possible, larger organisms seen to the naked eye while sieving 2–5 cm slice, were also photographed and preserved for further molecular studies (see *Live sorting and preservation procedure* below)
 - b. Sediment >5cm deep was discarded
8. Sieve sediment under CSFW with a 300µm sieve in the CT lab
9. Store residues and nodules in fridge in the wet lab to await sorting

Live sorting and preservation procedure

During sorting, every effort was made to keep specimens cold. CSFW was topped up regularly and kept on ice when not in use. Specimens waiting sorting were kept in the fridge and processed specimens were mainly preserved in cold 80 % ethanol (occasionally in 95 % ethanol or RNAlater) and then stored on ice or in the fridge in plastic microtubules. After at least 12 hours in the fridge since preservation, samples were moved to a freezer for long-term storage (-20°C).

1. Pick out specimens from sieving residues and place into a 'live sort' vial of CSFW stored on ice
2. Photograph specimens in CSFW under the microscope (Figure 37)
 - a. Specimens on nodules were photographed on the nodule and then removed and imaged again
3. Preserve specimens in cold 80 % ethanol* for molecular/taxonomic purposes
4. Store preserved specimens in fridge for 12–24 h
5. Transfer preserved specimens to freezer

*Large specimens (*e.g.*, from the amphipod trap or the trawl) were photographed and then a small tissue sample was removed and preserved in 80 % ethanol for molecular analyses. The main bulk of the individuals were preserved in 95 % ethanol, to be kept in the Discovery Collections at NOC, Southampton.

Since the molecular analyses will not be commenced until the samples are back at the NHM, it is difficult to assess the success of the sampling programme. However, we recovered a number of live specimens during the work and are confident that the cold chain method worked sufficiently well to allow for optimal preservation of DNA. Additionally, comparing the number of samples we were able to preserve with the number of specimens collected in previous cruises (*e.g.*, 'Abyssline' Project) confirms that this represents a successful cruise.



Figure 37. Photographic Equipment set up in the wet laboratory. Left: Canon EOS 700D camera mounted onto a Leica MZ6 dissecting microscope for photographing small specimens. Specimens were lit using a light box for sorting and two Canon flashguns for photography. Right: Canon EOS 600D mounted on a tripod for macrophotography of larger specimens. Specimens were lit using the two desk lamps and auxiliary flash was not generally necessary.

Preliminary Results

Preliminary observations

Of the 595 specimens collected by the NHM, 551 could be immediately assigned to a specific taxon (usually family or class). Others likely represented fragments or larval stages for which more detailed taxonomic analyses will be conducted at the NHM. A small number of morphospecies were observed several times (*e.g.*, Figure 38c & d) and diversity was moderately high, particularly for the infauna. Infauna were comprised predominately of crustaceans (Harpacticoida, Isopoda, Ostracoda, Cumacea, Decapoda) and annelids (polychaetes & oligochaetes), while fauna living directly on nodules were dominated by hexactinellid sponges and a spermiform cocoon presumably made by a platyhelminth turbellarian. Other taxa observed in both infaunal and epifaunal compartments include molluscs (Gastropoda and Bivalvia), cnidarians (Hydrozoa), echinoderms (Ophiuroidea) and nematodes, amongst others.

Interestingly, some organisms appeared as ovigerous females, including examples in the group of polychaetes (Figure 38f) and bivalves. Also, two symbiotic relationships were observed in the samples collected: a nematode parasitizing a copepod harpacticoid and a crustacean living inside a pelagic ascidiacean.



Figure 38. Selection of taxa sampled. a) Amphipod; b) Serpulid polychaete after being removed from its calcareous tube; c) Encrusting hexactinellid sponge on a nodule; d) An abundant tanaid (Crustacea, Peracarida); e) Eurythenes sp. (Peracarida, Amphipoda) collected from the amphipod trap; and f) Goniadid polychaete, ovigerous female releasing eggs.

Macrofaunal Density

Although assemblage composition data has not yet been resolved, we were able to take a dataset of macrofaunal density in the APEI concurrently with our sampling programme (Table 17) derived from box- and megacore samples. It was clear that the megacorer was more efficient at recovering specimens per unit area, but owing to the very low faunal density, boxcores represented a sensible sampling gear, as well as facilitating the collection of a larger number of nodules for morphometric analyses.

| Sites | Replicates (Box-/ Megacore) | Mean Individuals (m ²) | Standard Deviation |
|------------|--------------------------------|---------------------------------------|-----------------------|
| Deep Plain | 6 (3 / 3) | 173.9 | 139.9 |
| Ridge | 9 (5 / 4) | 128.0 | 92.0 |
| Flat | 7 (5 / 2) | 102.1 | 119.9 |
| Trough | 9 (5 / 4) | 89.0 | 97.8 |

Table 17. Macrofaunal density in APEI 4. Data represent specimens found in the top 10 cm of sediment of megacores and the top 2 cm of boxcores. Opportunistic samples that could not feasibly be quantitatively constrained or lacking replicates (i.e., trawls, HyBIS and megacore from Volcano site) are not reported here.

Further Work

Our preliminary observations on fauna collected during our sampling, suggest that diversity within the APEI is moderate. However, further work should be conducted to compare these data with other from similar areas from the vicinities (*e.g.*, ‘Abyssline’ Project), which will allow a better diagnosis of our preliminary observations. Thus, the capacity of the APEI to provide an effective reserve area for local mining claims remains a key question for future study. After the samples collected and preserved during this cruise will be at the NHM, specimens will be sorted into morphospecies and then selected for molecular/taxonomical analyses in conjunction with available material from other cruises to assess genetic connectivity around the Clarion-Clipperton Zone, specifically between reserve areas and mining claims (UK, Singapore and Germany). Genetic flow between target species across and within these areas will be done using different mitochondrial and nuclear markers.

Lessons Learnt & Suggested Improvements

The first boxcore samples (JC120-013, JC120-014, JC120-015) were processed following the original suggested protocol, which consisted in taking a ca. 20 x 20 cm subsample of the 0–2 cm and the 2–5 cm sections. We quickly observed that little or even no biological material was obtained after sieving and sorting these fractions. After discussing the problem with other members in the cruise and one of the PIs of the Abyssline project at the NHM (Adrian Glover), we decided to process the whole boxcore 0–2 cm slice. This substantially increased the number of organisms encountered per sampling station. Occasionally, large organisms found in the 2–5 cm boxcore layer were also preserved for molecular/taxonomic purposes. To minimize damage of these organisms that were sieved using warm seawater (ca. 26°C) in the sieving table, once spotted they were immediately transferred to cold seawater and put into the fridge. We encourage using these methods during future cruises in order to maximize the number of samples obtained from each boxcore.

We encountered a problem with topwater draining from the boxcore, posing a considerable threat of specimen loss during hauling. The penetration limiters on the boxcore were removed and this did reduce topwater loss, although the water was still between 22–26°C (and occasional measurement of the temperature of the mud of boxcore JC120-073 allowed us to record a temperature of 12°C at 10 cm and 8°C at 25 cm) once recovered on deck, which is not ideal for preservation of good quality material. Megacore deployments were in general much more successful than boxcores and returned a

mean of 1.9–7.2 times as many specimens per unit area as did the boxcores (though this estimate may reduce following sorting of the 2–5cm section of the boxcores). However, given the relatively low faunal density (Table 17) in the CCZ, the number of megacores required to match the number of samples taken from boxcores would have been impractical.

The examination of nodules in the search of epifaunal organisms was slightly different from the original suggested protocol. After removing them from the corresponding megacore and boxcore sample they were carefully rinsed and put into CFSW. After that, they were thoroughly examined under the microscope since most of the epifauna was difficult to observe to the naked eye. In our opinion, this substantially increased the number of specimens encountered in the samples since epifaunal organisms represented ~39 % of the total.

Other Notes

James Bell and Sergi Taboada conducted blogging through the JC120 WordPress account and through twitter. Tweets about general cruise updates/macrofaunal photos and links to the blog received several RTs and positive feedback from readers worldwide. In particular, the combination of the blog and faunal photos were successful in creating interest in the cruise.

Photos and data were backed up on the NHM laboratory desktop, an external HDD and the QNAP storage (Clarion drive).

Meiofauna analysis (benthic foraminifera)

Clémence Cauille

General aim

The Clarion Clipperton Zone seabed is characterized by the presence of manganese nodules. This feature may impact the fauna. The aim of this study is, therefore, to describe the meiofauna density, diversity and community structure in relation to the density of manganese nodule. To get more details about benthic foraminiferal diversity, DNA analyses will be carried.

Sampling and analyses

Sampling and analyses were conducted according to the “cold chain procedure” (see NHM macrofauna section). This procedure maximizes the chance of preserving live organisms. As a result, analyses were conducted in the cold room (~ 4°C).

Quantitative meiofauna

At all stations one large megacorer (Ø10 cm) was sampled for quantitative meiofaunal (living and dead) study (Table 18). The top 2 cm of sediment was sampled at 0.5 cm resolution, between 2-6 cm at 1 cm resolution and between 6 and 10 cm at 2 cm resolution. The top sediment sea-water (~0-2 cm) was preserved with the first sediment layers (0-0.5 cm). Nodules, if present, were added in the corresponding sediment layers. All samples were subsequently stored in 10 % formalin.

| Station | Gear | Tube | Number of samples | Analysis | Preservative |
|-----------|-----------|------|-------------------|------------------------|--------------|
| JC120-012 | Megacorer | S | 10 (0-10 cm) | quantitative meiofauna | 10% Formalin |
| JC120-019 | Megacorer | E | 10 (0-10 cm) | quantitative meiofauna | 10% Formalin |
| JC120-023 | Megacorer | R | 10 (0-10 cm) | quantitative meiofauna | 10% Formalin |
| JC120-024 | Megacorer | L | 10 (0-10 cm) | quantitative meiofauna | 10% Formalin |
| JC120-028 | Megacorer | E | 10 (0-10 cm) | quantitative meiofauna | 10% Formalin |
| JC120-034 | Megacorer | R | 10 (0-10 cm) | quantitative meiofauna | 10% Formalin |
| JC120-049 | Megacorer | F | 10 (0-10 cm) | quantitative meiofauna | 10% Formalin |
| JC120-058 | Megacorer | P | 10 (0-10 cm) | quantitative meiofauna | 10% Formalin |
| JC120-059 | Megacorer | F | 10 (0-10 cm) | quantitative meiofauna | 10% Formalin |
| JC120-062 | Megacorer | D | 10 (0-10 cm) | quantitative meiofauna | 10% Formalin |
| JC120-064 | Megacorer | Q | 10 (0-10 cm) | quantitative meiofauna | 10% Formalin |
| JC120-065 | Megacorer | X | 10 (0-10 cm) | quantitative meiofauna | 10% Formalin |
| JC120-066 | Megacorer | K | 10 (0-10 cm) | quantitative meiofauna | 10% Formalin |

| | | | | | |
|-----------|-----------|---|--------------|------------------------|--------------|
| JC120-067 | Megacorer | E | 10 (0-10 cm) | quantitative meiofauna | 10% Formalin |
| JC120-075 | Megacorer | L | 10 (0-10 cm) | quantitative meiofauna | 10% Formalin |
| JC120-076 | Megacorer | T | 10 (0-10 cm) | quantitative meiofauna | 10% Formalin |
| JC120-084 | Megacorer | Q | 10 (0-10 cm) | quantitative meiofauna | 10% Formalin |
| JC120-092 | Megacorer | J | 10 (0-10 cm) | quantitative meiofauna | 10% Formalin |

Table 18. Samples retrieved for quantitative meiofauna analysis.

Meiofauna DNA

Specimens were collected at different stations (see appendix). Sediment samples (0-1 cm) were taken in the same megacore as eDNA samples (Curtis Robert Young). Opportunistic samples were also retrieved on boxcore and megacore, shared with the NHM.

Living benthic foraminifera (>300 and 150-300 μm) from surface sediments (0-1 cm) were picked and examined on board, using a binocular microscope. The identification of living foraminifera was based on robust coloration of foraminiferal protoplasm. Collected specimens were pictured using Canon EOS 700D (courtesy of the Natural History Museum). All analyses were carried out according to the cold chain procedure. Samples were sieved under 150 and 300 μm mesh in the cold room (4°C). Sorting, taxonomy and photo were made on ice. Each specimen was preserved in RNAlater in separate Eppendorf and freeze to -22°C. Some specimens were dry in separate Eppendorf. The collected samples (462 specimens) are intended for DNA analyses.

Additional material

Mega-foraminifera (Xenophyophores) when found on megacore or boxcore, were pictured and dried (Table 19).

| Station | Type | Tube | Species | Where | Preservative |
|-----------|------------|------|---------------------------|-----------------|--------------|
| JC120-005 | Hybis grab | | <i>Psammmina</i> sp. | petri dishes | Dry |
| JC120-049 | Megacorer | C | <i>Psammmina</i> sp. | petri dishes | Dry |
| JC120-050 | Boxcore | | <i>Aschemonella</i> sp. 2 | petri dishes | Dry |
| JC120-050 | Boxcore | | <i>Aschemonella</i> sp. 2 | eppendorf (n°A) | Dry |
| JC120-055 | Boxcore | | "tree" attached nodule | petri dishes | Dry |
| JC120-055 | Boxcore | | <i>Aschemonella</i> sp. | petri dishes | Dry |
| JC120-055 | Boxcore | | <i>Aschemonella</i> sp. | petri dishes | Dry |
| JC120- | Boxcore | | <i>Psammmina</i> sp. | petri dishes | Dry |

| | | | | | |
|------------------|-----------|---|-----------------------|--------------|-----|
| 077 | | | | | |
| JC120-077 | Boxcore | | Psammina sp. | petri dishes | Dry |
| JC120-077 | Boxcore | | Aschemonella sp.2 | petri dishes | Dry |
| JC120-082 | Boxcore | | "pustule" foram | petri dishes | Dry |
| JC120-092 | Megacorer | C | Aschemonella sp. 3 ?? | petri dishes | Dry |

Table 19. List of collected dry samples.

Dead benthic foraminifera were also sorted out and preserved in ethanol (in Eppendorf) from station JC120-005 and JC120-90 (> 300 µm, 0-1 cm), in order to give a general idea of the species diversity at these sites.

Preliminary results

Analyses of benthic foraminifera on board give a general idea on common taxa at sites.

Benthic foraminifera attached to nodule

Megafauna (Xenophyophores)

The CCZ appears very rich in Xenophyophores. A total of 7 different species were observed: *Aschemonella* sp. (smooth form), *Aschemonella* sp. 2 (like – lattice form), ?*Aschemonella* sp. 3 (dome form), *Psammina* sp., encrusting species (chain of pustule form and lichens form) and *Saccorhiza* sp.. Most of these species were found attached or living on nodule, always on the sediment surface. Although the encrusting “chain of pustule” form (see *Figure* below, top right hand side) was always present on nodule, this form faces the sediment. The species ?*Aschemonella* sp. 3 (*Figure* 39, bottom left hand side) was not attached to nodules but present on the sediment surface. Some specimens, supposed alive, were preserved in RNA later for further DNA analysis.

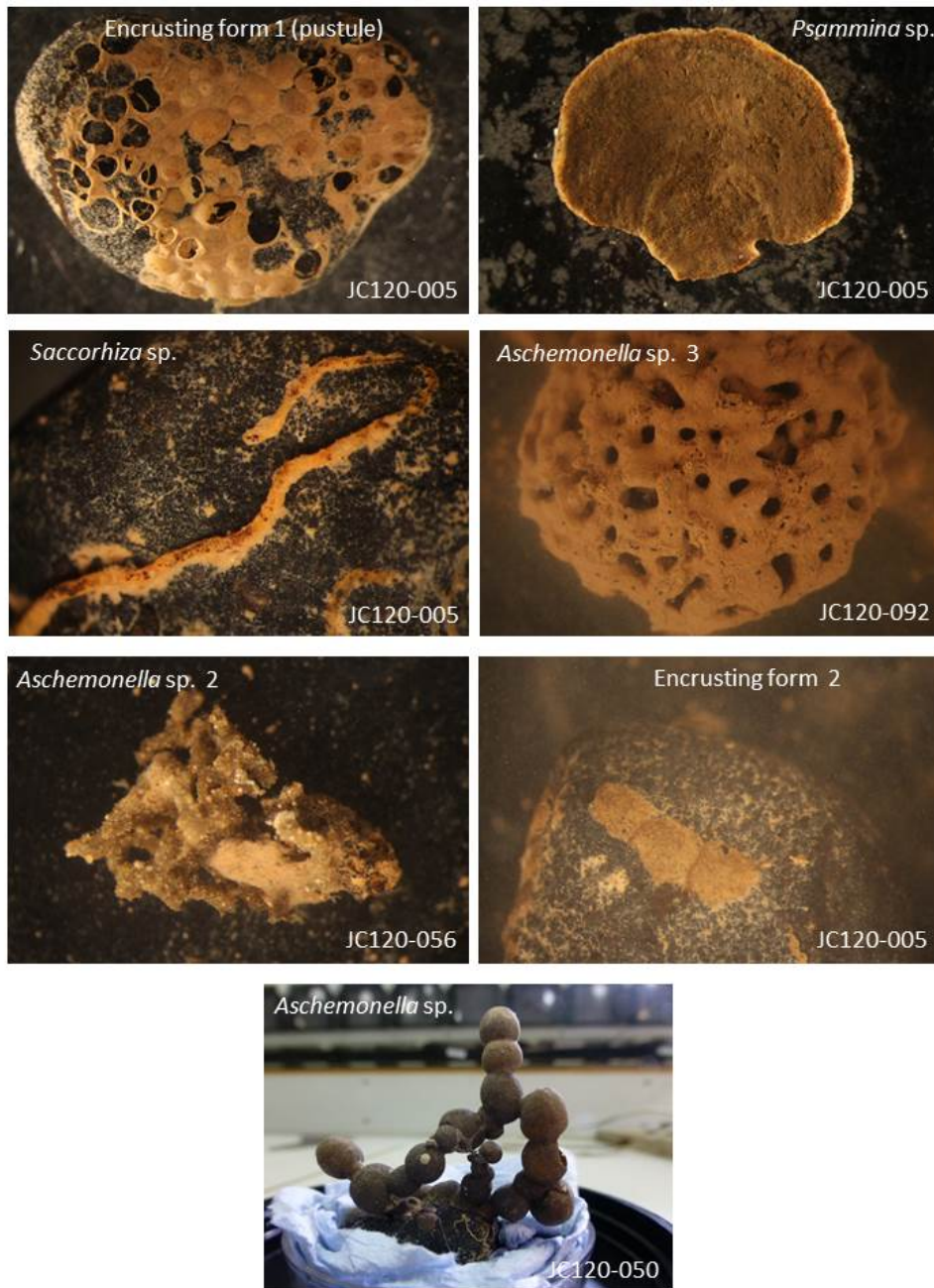

Figure 39. Example of the different form of Xenophyophores found at different sites.

Others species

Some small white dome (Figure 40; left hand side) and calcareous species (right hand side) were observed attached to nodule; most of them were taken for DNA analysis.

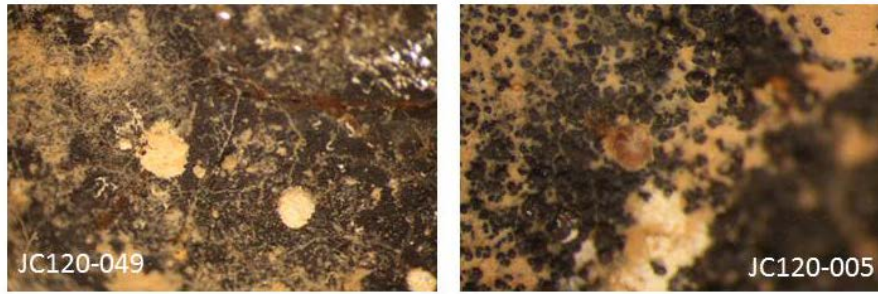

Figure 40. Illustrations of live benthic foraminiferal species attached to nodule

Meiofauna

Benthic foraminiferal fauna were very similar between the four studied sites (Deep plain, Flat area, Ridge area and Trough area), indicating few changes between sites. At all stations several *Reophax* species dominated the benthic foraminiferal assemblages, some using tiny nodule to build their test (Figure 41). Large (> 300 µm) dead *Nodosinum gausasicum* were also observed at most of the stations.

Few agglutinated (except *Reophax* species) and calcareous species were observed lived. Calcareous fauna were composed of: *Nuttalides* sp., *Cibicidoides* sp., *Pullenia* sp., *Melonis* sp., *Epistominella* sp., *Cornuspira* sp., *Quinqueloculina* sp and *Triloculina* sp.. Agglutinated fauna were dominated by *Cribrostomoides* species, *Glomospira* sp., *Trochammina* species, *Buzasina* sp., *Cyclammina* sp. and *Cystammina* species.

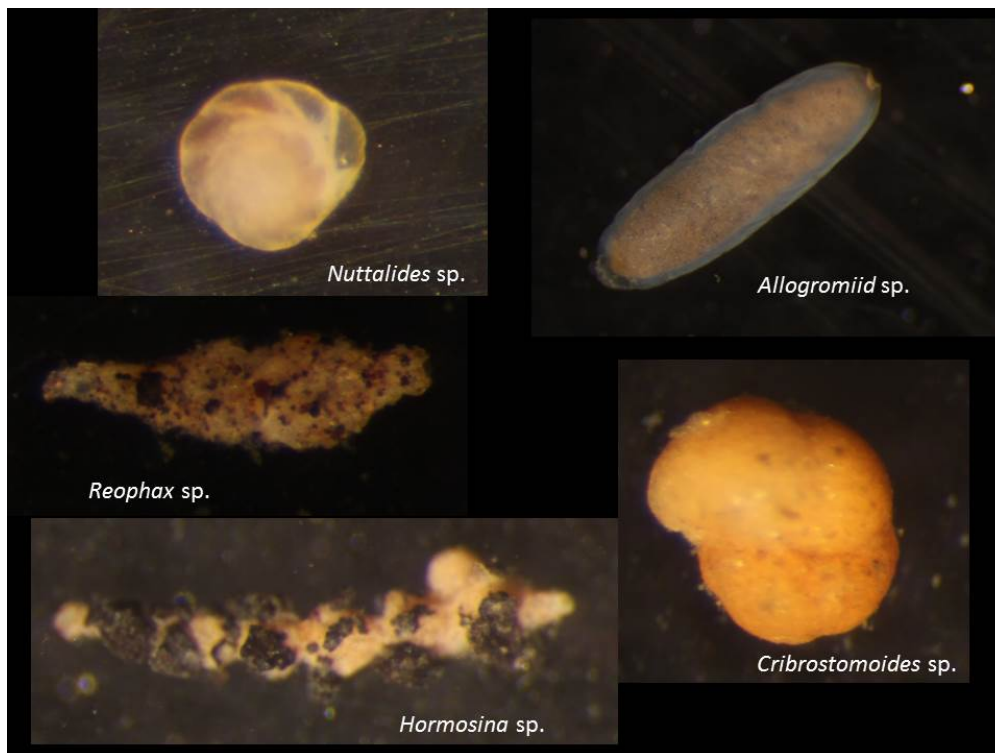

Figure 41. Example of live benthic foraminiferal species present in the CCZ.

At station JC120-090 (Volcano), surprisingly high abundance of dead planktonic foraminifera was found. Micro-plastics were also reported at this station. Benthic foraminiferal fauna were more diverse and exhibited different species (e.g. *Pyrgo murrhina*, *Globocassidulina subglobosum*, *Ehrenbergina pacifica*, *Uvigerina* sp.). The water depth between this site and previous stations, of ~1000 m, may explain the observed pattern.

Megacore samples for eDNA

C. Rob Young

All megacore samples collected for eDNA studies were sectioned by depth profiles to correspond to geochemistry cores. The first 10cm were sliced by 1cm sections. After 10cm depth, sections were increased to 2cm. Sediment horizons were collected in individual sterile whirlpaks and frozen immediately at -80C. Care was taken to avoid sampling sediment in contact with the edges of the core. Table 20 contains a summary of sample locations, depths, and associated information. This study design includes 4-5 replicate samples for each main site as well as one sample from Volcano and two samples from the UK1 claim site. In addition, 12 nodules were collected and preserved for DNA and RNA studies. These sediment and nodule samples will be used to determine the spatial variability of microbial diversity (e.g., 16S amplicon surveys), assess the diversity of eukaryotic communities (e.g., 18S and/or COI amplicon surveys), determine the functional diversity of microbial communities (e.g., metagenomic shotgun sequencing), and assess microbial activities (e.g., metatranscriptomic shotgun sequencing). These studies will provide information on baseline microbial communities in an undisturbed nodule habitat.

CTD sampling for eDNA

C. Rob Young

Samples of water were collected using Niskin bottles during CTD casts. Water samples were immediately transferred to 5L sterilized jerry cans and kept at 4C until filtering. Samples were filtered through 0.2um Stirivex cartridge filters. After filtration, excess water was removed with a syringe, and 2ml of Lifeguard preservative was added to the filter cartridge. Filters were then immediately frozen at -80C. Filter lines were sterilized between CTD casts. When more than 4 samples were filtered from a cast, lines were washed with milli-Q filtered water and then washed with the water to be filtered. Samples were generally collected near bottom, at 50m altitude, 100m altitude and 500m altitude. The 500m altitude was adjusted for shallower samples to 3800m depth in some cases to provide a common depth across sites. Replicate samples were collected for RNA studies when possible, however, due to a limited number of available filters, replicate samples were not collected from all locations. One sample (Edge of EEZ), surface samples and samples across the OMZ were collected. Sample collections are summarized in Table 21. These water samples will be used to determine the spatial variability of microbial diversity (e.g., 16S amplicon surveys), assess the diversity of eukaryotic communities (e.g., 18S and/or COI amplicon surveys), determine the functional diversity of microbial communities (e.g., metagenomic shotgun sequencing), and assess microbial activities (e.g., metatranscriptomic shotgun sequencing).

| Event | Cast | Location | Latitude (N) | | Longitude | | Depth (m) | Max. Sediment Depth (cm) | # Samples | Core |
|--------|-------------|--------------|--------------|---------|-----------|---------|-----------|--------------------------|-----------|------|
| | | | Deg | Min | Deg | Min | | | | |
| JC120- | Megacore-1 | Deep Plain 1 | 16 | 54.7770 | 122 | 59.8290 | 4297 | 36 | 23 | geo |
| JC120- | Megacore-2 | Deep Plain 1 | 16 | 54.7630 | 122 | 59.8372 | 4297 | 34 | 22 | P |
| JC120- | Megacore-3 | Flat 2 | 17 | 14.9340 | 123 | 1.2870 | 4162 | 36 | 23 | A |
| JC120- | Megacore-4 | Flat 3 | 17 | 15.0220 | 123 | 1.7590 | 4155 | 5 | 5 | S |
| JC120- | Megacore-5 | Flat 1 | 17 | 14.4476 | 123 | 3.9773 | 4156 | 34 | 22 | P |
| JC120- | Megacore-6 | Flat 4 | 17 | 13.1865 | 123 | 2.6686 | 4180 | 34 | 22 | E |
| JC120- | Megacore-8 | Trough 1 | 17 | 13.0659 | 122 | 49.3857 | 4236 | 34 | 22 | P |
| JC120- | Megacore-9 | Trough 2 | 17 | 9.4655 | 122 | 48.7848 | 4291 | 34 | 22 | B |
| JC120- | Megacore-10 | Ridge 1 | 17 | 21.5571 | 122 | 54.1743 | 4015 | 36 | 23 | geo |
| JC120- | Megacore-11 | Ridge 1 | 17 | 21.5566 | 122 | 54.1736 | 4015 | 34 | 22 | C |
| JC120- | Megacore-12 | Ridge 2 | 17 | 18.8441 | 122 | 54.0456 | 4038 | 34 | 22 | A |
| JC120- | Megacore-13 | Ridge 3 | 17 | 22.0117 | 122 | 53.9258 | 4029 | 8 | 8 | J |
| JC120- | Megacore-14 | Trough 3 | 17 | 8.7250 | 122 | 48.5180 | 4282 | 34 | 22 | Q |
| JC120- | Megacore-15 | Trough 1 | 17 | 13.0580 | 122 | 49.3917 | 4245 | 30 | 20 | geo |
| JC120- | Megacore-17 | Ridge 4 | 17 | 17.3005 | 122 | 53.0735 | 4012 | 32 | 21 | C |
| JC120- | Megacore-18 | Ridge 4 | 17 | 19.6750 | 122 | 53.2740 | 4012 | 30 | 20 | T |
| JC120- | Megacore-19 | Trough 5 | 17 | 17.7890 | 122 | 50.1280 | 4234 | 32 | 21 | F |
| JC120- | Megacore-20 | Flat 5 | 17 | 14.3809 | 123 | 1.5938 | 4158 | 34 | 22 | D |
| JC120- | Megacore-21 | Flat 3 | 17 | 15.0484 | 123 | 1.7629 | 4153 | 34 | 22 | J |
| JC120- | Megacore-22 | Deep Plain 3 | 16 | 54.4400 | 123 | 1.5040 | 4300 | 34 | 22 | P |
| JC120- | Megacore-23 | Volcano | 16 | 52.3749 | 122 | 41.9143 | 3444 | 24 | 25 | F |
| JC120- | Megacore-24 | Deep Plain 2 | 16 | 54.1431 | 123 | 0.9724 | 4290 | 34 | 22 | B |
| JC120- | Megacore-26 | UK claim | 13 | 27.7888 | 116 | 36.4874 | 4108 | 34 | 22 | J |
| JC120- | Megacore-27 | UK claim | 13 | 27.8015 | 116 | 36.4899 | 4108 | 0-1, >1* | 5 | H |

*Table 20. Megacore samples: Sediment samples collected from megacore. "geo" denoted cores collected for geochemistry. *This core contained a large nodule. Sediment was collected from the undisturbed 0-1cm depth before nodule removal. After nodule removal, four sediment samples were taken from the surrounding sediment. These samples are denoted >1cm due to the uncertainty in the depth horizon.*

Latitude (N) Longitude (W)

| Event | Cast | Location | Deg | Min | Deg | Min | Depth (m) | # samples | Depth (m) | # samples | Depth (m) | # samples | Depth (m) | # samples |
|------------|-------|----------------|-----|---------|-----|---------|--------------|--------------|--------------|--------------|--------------|--------------|--------------|--------------|
| JC120-001* | CTD-1 | Edge of EEZ | 17 | 26.0600 | 118 | 12.9100 | 3932 | 3 | 3882 | 3 | 3832 | 3 | 3432 | 3 |
| JC120-004 | CTD-2 | Nodule Site | 16 | 53.8100 | 122 | 51.2780 | 4291 | 3 | | | | | | |
| JC120-009 | CTD-3 | Deep Plain 1 | 16 | 54.7770 | 122 | 59.8270 | 4294 | 3 | 4244 | 2 | 4194 | 2 | 3794 | 2 |
| JC120-035 | CTD-4 | Trough 1 | 17 | 13.0707 | 122 | 49.3910 | 4236 | 3 | 4186 | 2 | 4136 | 2 | 3736 | 2 |
| JC120-052 | CTD-5 | Flat 1 | 17 | 14.4118 | 123 | 3.9780 | 4160 | 1 | 4110 | 1 | 4060 | 1 | 3800 | 1 |
| JC120-053 | CTD-6 | Ridge 1 | 17 | 21.5154 | 122 | 54.1747 | 4024 | 1 | 3974 | 1 | 3924 | 1 | 3800 | 1 |
| JC120-095 | CTD-7 | Volcano | 16 | 52.2980 | 122 | 41.6360 | 3460 | 1 | 3410 | 1 | 3360 | 1 | 2960 | 1 |
| JC120-098 | CTD-8 | UK claim | 13 | 28.5000 | 116 | 44.9997 | 4217 | 1 | 4167 | 1 | 4117 | 1 | 3717 | 1 |

*Table 21. CTD samples: Water samples collected by Niskins and filtered. *This sample also included 3 samples at 25m, 120m (OMZ), and 500m depth.*

Geochemistry Group Sampling and Methods

D. Connelly, J. Felden, P. Josso, A. Lichtschlag, A. Menendez, K. Peel, N. Shulga

To address the depositional and biogeochemical processes and the redox conditions that might support Mn-nodule formation in the Clarion Clipperton Fracture Zone, water samples, sediment solid phase samples, sediment porewater samples, and Mn-nodules were collected. In addition oxygen and pH profiles were measured in the retrieved sediment cores. This was done in areas with different topography (deep plain, trough, ridge, flat, extinct volcano) in the Area of Particular Environmental Interest (APEI) and one site in the UK licence area (Table 22).

Water column sampling

Typically four water depths were sampled with Niskin bottles mounted to the CTD frame (Figure 42); 4 bottom water samples at 5, 10 and 20 m off the seafloor and one reference sample at 2800 m. Water samples were collected for dissolved trace metals, DIC, nutrients, and dissolved oxygen.

Samples for dissolved oxygen concentration measurements were collected in 100 ml glass bottles immediately when the CTD was secured on deck. 1 mL MnCl_2 and 1 mL NaOH/NaI was added on deck and the solutions shaken vigorously until well mixed. Samples were allowed to settle for >8 hours. Dissolved oxygen was then determined by the Winkler titration method (*Winkler, 1888*), detection limit $1 \mu\text{mol O}_2 \text{ L}^{-1}$) in the lab on the ship. Seawater samples were collected for DIC in 250 mL glass bottles with quick-fit ground glass stoppers. Once sealed 100 μL saturated HgCl_2 was added to the DIC bottles to preserve them. Both oxygen and DIC samples were collected using silicone tubing, with a Teflon insert, with care to avoid the formation of bubbles. To minimise contact with the atmosphere at least twice the volume of the containers was allowed to overflow.

Water samples were also retained for nutrients and trace metal analysis; water for nutrient analysis was collected in 30 mL plastic vials and frozen at -20°C . The Niskin bottles were removed from the CTD frame and taken to the clean laboratory van. The Niskin bottles were connected to a low pressure clean nitrogen system and the bottles clamped and 500 mL was filtered directly from the Niskin through $0.2\mu\text{m}$ nuclepore/cyclopre membrane filters. Both the filtrate and the filters were retained; the filtrate was preserved with 0.5ml of high purity nitric acid, the filters were bagged and frozen at -20°C . For some water depths samples were collected by R. Young (NOC) for eDNA (see Table 22).



Figure 42. Niskin bottles mounted into the CTD frame before and during deployment.

Sediment sampling

Sediments were obtained with a Gravity corer (GC) recovering a core length of up to 3 m (Figure 43a) and with a Mega corer (MC) (Figure 43), collecting approximately the upper 40 cm of the seafloor sediments (Figure 43b). Immediately after retrieval, the GC's were sectioned in 0.5 m intervals, capped and transported into a controlled temperature (CT) room cooled to 7 °C (Figure 43b). The sections were stored for several hours to adjust the sediments to room temperature. Afterwards, holes were carefully drilled into the plastic GC liner every 10 to 20 cm. Before subsampling of solid phase or porewater, oxygen concentrations of the sediment were determined using needle-type fiber-optical oxygen microsensors (OXR50-OI, PyroScience®). To avoid measuring any oxygen diffusing from the outside into the sediment as might have happened during recovery and storage, the oxygen sensor was slowly driven vertically towards the centre of the core until the signal was stable. After completion of the oxygen measurements, additional holes for subsampling were drilled into the plastic GC liner for porewater extraction, and then taped to limit oxygen contamination, and the sections were transferred into a glove box filled with nitrogen for subsampling sediments and porewater under an oxygen-free atmosphere.



Figure 43. Gravity Corer (GC). 2a) whole 3m core resting in deck straight after recovery. 2b) 50 cm core section after storage in cold room.

Porewater was extracted from sediments directly with Rhizons (Rhizon CSS: length 5 cm, pore diameter 0.2 μm ; Rhizosphere Research Products, Wageningen, Netherlands) inserted through pre-drilled holes in the GC liners and connected to a syringe on which a small underpressure was applied (Figure 45). The same intervals were collected for each GC section, 5, 15, 25, 35 and 45 cm. Aliquots of porewater were collected for cations (3 mL), DIC (2.5 mL) nutrients (3 mL) and a combined volume of 7 ml for rare earth elements (REE's) was collected for each segment. For some core samples additional opportunistic samples were collected for R. Young of the NOC for eDNA samples.

The cation and REE samples were acidified (10 μL of conc. suprapure HNO_3) for later analyses by ICP-MS/ICP-OES. DIC samples were poisoned with saturated HgCl_2 (5 μL) to prevent further microbial turnover. In addition, total alkalinity was measured on board immediately as described below. Remaining porewater was frozen at -20 °C for nutrient analyses.



Figure 44. Mega Corer (MC). 3a) MC frame on deck at deployment. 3b) Core liner after recovery.

Following this sampling regime the core sections were removed from the glove bag and a 1.3 cm hole was drilled offset from the small sampling holes by two cm. A syringe with the tip cut off was inserted and an 8 ml plug of sediment was removed. This section was split into two parts; the first was frozen into a plastic bag for solid phase metals and CNS (carbon, nitrogen, sulphur) analysis, the second part was placed in a pre-weighed pot for a measurement of porosity and sedimentation rates, and a measurement of pH was made on this sample.

MC samples were treated and sampled with Rhizons in the same way as the GC samples, with a sampling interval of 1 or 2 cm, and the core liners for the Megacorer were pre-drilled and covered in tape for deployment.

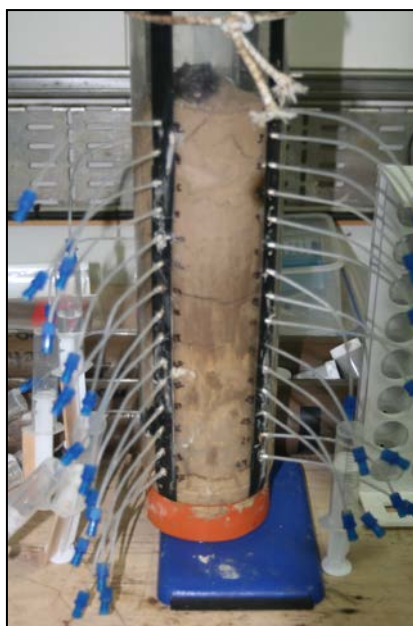

Figure 45. Porewater extraction in Mega Core sample using Rhizons.

For some of the initial core samples subsample of the porewater was analysed for dissolved iron. For this 0.5 mL of sample was collected and added to an aliquot of ferrozine solution under an N_2 atmosphere within 2 minutes of collection to allow determination of dissolved FeII (Stookey, 1970). Filtration of porewater was not necessary as the Rhizons used to extract water effectively filter the collected water at around $0.2 \mu m$. Once FeII had been determined spectrochemically at 562 nm, Fe_{Tot} (aq) was determined by the addition of ascorbic acid. Ammonium was determined on the first cores by using the spectroscopic indophenol blue method of (Grasshoff, 1983). Our early results indicated that the cores were all oxic to some degree and hence there was no dissolved iron or ammonium, hence this analysis was stopped. Total alkalinity was determined by titration against $0.0004 \text{ mol L}^{-1}$ HCl using a mixture of methyl red and methylene blue as an indicator. Analyses were calibrated against the IAPSO seawater standard.

For sediment solid phase collection at each sampling site one collected megacores was sampled directly by extruding the core from the liner. The cores were sectioned into 1 or 2 cm intervals, a sample for porosity and a measurement of pH was collected as before, the remainder of each segment was bagged and frozen at $-20 \text{ }^\circ\text{C}$ for metal and CNS analyses. Examples of pH profiles are plotted in Figure 46.

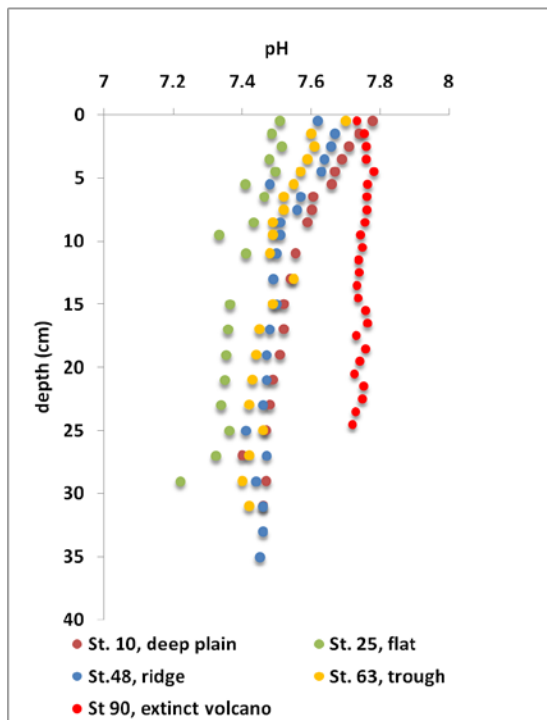

Figure 46. pH profiles measured in sediments collected with the Mega corer in the different topographic areas in the APEI.

Oxygen measurements were also performed on retrieved megacores to determine diffusive oxygen uptake and oxygen penetration depth in the sediments. The oxygen concentration at the sediment-water interface and surface layers of the sediment were accessed by using needle-type fiber-optical oxygen microsensors (OXR50-OI, PyroScience©). The measurements were performed in 100 μm resolution and a total length of up to 5 centimetres. Oxygen concentration between 5 and 30 cm depths were measured at 2 cm intervals by inserting Robust Oxygen Miniprobe (PyroScience©) vertical through predrilled holes into the sediment. An example of an oxygen profile combined from measurements in MCs and GCs can be found in Figure 47.

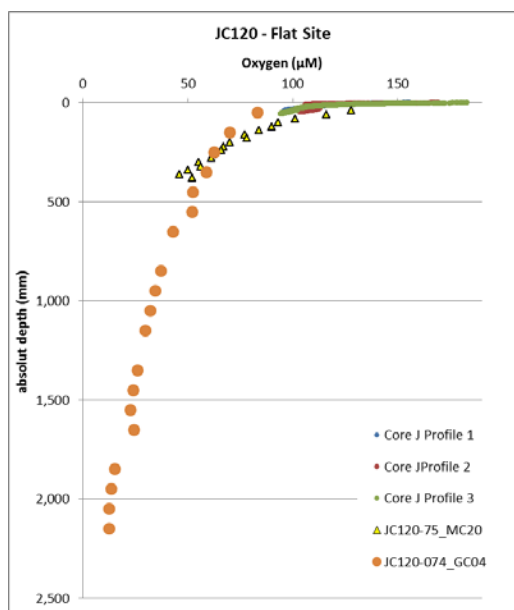

Figure 47. Combined oxygen concentration profiles gained from gravity cores and mega cores indicate oxygen penetration depth of more than 2.50 m with rather low oxygen consumption rates even at the sediment surface.

Special attention will be paid to analyses of REE (Rare Earth Elements) in the sampled sediments. For analyses of REE, the sediments will be washed in MQ and oven-dried at approximately 50 °C. Then, they will be ground and a small subsample of 100 mg will be taken and subjected to a HF+HClO₄+HCl chemical digestion. Subsequently samples will be measured on an ICP-MS to obtain concentrations of major metals, REE and other trace elements. In this low-sedimentation rate area, a hydrogenous signature is expected on the REE distribution patterns, as well as a linear relationship with Fe, reflecting the active uptake of REE by Fe-hydroxide phases and precipitation, with no major diluting agents (continent-detrital or carbonates). Cerium anomalies are thus expected to look positive, and LREE enriched with respect to HREE. However, a weak hydrothermal signature might also be measured, due to the nearby volcanism in the area.

Mn-nodule sampling

Mn nodules were obtained by trawling, box coring, with the HYBIS grab and collected from MC's and GC's. Nodules were dried for REE and organic matter analyses, and stored in seawater with a headspace at 4 °C for microbial analyses. For REE analysis of the nodules two approaches will be used: some nodules will be selected for a detailed mineralogical, textural and geochemical study of individual layers, whereas the rest will be analysed in a bulk perspective. In the former group, polished and thin sections will be used for SEM, reflected and transmitted microscopy observations. Layers in the ground surfaces will be sampled using micromill, and analysed following a similar chemical digestion to that of sediments.

In addition to these detailed analysis, a representative quantity of nodules from each trawl (approximately 500g) will be powdered and analysed through sequential leaching experiments. Comparison of each leachate with bulk composition will allow better understanding of trace metals association with the Fe-Mn phases.

For organic matter analyses nodule samples as well as sediment and porewaters and will be extracted by sonication in a dichloromethane solvent. Biomarker hydrocarbons (alkanes, fatty acids, isoprenoids) from the solvents extracts will be analyzed by gas chromatography-mass spectrometry (GC-MS). Component identification will be based on comparison of the GC retention times and the mass spectra from NIST and WILLEY libraries. Investigation of hydrocarbon biomarkers based on the variations of different ratio allows identification of the main sources and features of the geological and biogeochemical transformation of organic matter (Peters and Moldowan, 2004). This hydrocarbon compositional data together with metals contents can help us to determine actual role of organic matter in the formation, mobilization or accumulation elements in the obtained Fe-Mn nodules.

| Station | Event | Location name | Latitude | | Longitude | | Water depth m |
|---------|--------|---------------|--------------|---------|--------------|---------|------------------|
| | | | degrees N | minutes | degrees W | minutes | |
| 1 | CTD 01 | Edge of EEZ | 17 | 26.060 | 118 | 12.910 | 3932 |
| 4 | CTD 02 | Nodule site | 16 | 53.814 | 122 | 51.278 | 4291 |
| 9 | CTD 03 | Deep plain | 16 | 54.777 | 122 | 59.828 | 4292 |
| 35 | CTD 04 | Trough | 17 | 13.069 | 122 | 49.391 | 4008 |
| 52 | CTD 05 | Flat | 17 | 14.321 | 123 | 38.850 | 4160 |
| 53 | CTD 06 | Ridge | 17 | 21.515 | 122 | 54.170 | 4024 |
| 95 | CTD 07 | Volcano | 16 | 52.299 | 122 | 41.636 | 3460 |
| 17 | GC 01 | Deep plain | 16 | 54.739 | 122 | 59.811 | 4297 |
| 33 | GC 02 | Trough | 17 | 13.068 | 122 | 49.391 | 4236 |
| 54 | GC 03 | Ridge | 17 | 21.515 | 122 | 54.174 | 4024 |
| 74 | GC 04 | Flat | 17 | 14.448 | 123 | 3.979 | 4162 |
| 81 | GC 05 | Deep plain | 16 | 54.790 | 122 | 59.817 | 4290 |
| 101 | GC 06 | UK Claim | 13 | 27.783 | 116 | 36.507 | 4175 |
| 10 | MC 01 | Deep plain | 16 | 54.778 | 122 | 59.828 | 4292 |
| 25 | MC 07 | Flat | 17 | 14.423 | 123 | 3.994 | 4158 |
| 48 | MC 10 | Ridge | 17 | 21.504 | 122 | 54.225 | 4024 |
| 63 | MC 15 | Trough | 17 | 13.059 | 122 | 49.383 | 4245 |
| 90 | MC 23 | Volcano | 16 | 52.388 | 122 | 41.912 | 3419 |
| 105 | MC 24 | UK Claim | 13 | 27.813 | 166 | 36.496 | 4113 |

Table 22. Overview of sampling locations (CTDs, GCs and Mcs).

| Station | Event | Water depth m | Samples taken for geochemistry Water depth m | Samples taken for eDNA Water depth m |
|---------|--------|------------------|----------------------------------------------------|-----------------------------------------|
| 1 | CTD 01 | 3932 | | 3800 |
| | | | | 3763 |
| | | | | 3713 |
| | | | | 3300 |
| | | | | 500 |
| | | | | 127 |
| | | | | 32 |
| 4 | CTD 02 | 4291 | | 4178 |
| 9 | CTD 03 | 4292 | 4287 | 4287 |
| | | | 4281 | 42 |
| | | | 4271 | |
| | | | 2803 | |
| 35 | CTD 04 | 4008 | 4320 | 4320 |
| | | | 4225 | 4185 |
| | | | 4215 | 4135 |
| | | | 2800 | 3735 |
| 52 | CTD 05 | 4160 | 4147 | 4147 |
| | | | 4143 | 4101 |
| | | | 4122 | 4048 |
| | | | 2800 | 3798 |
| 53 | CTD 06 | 4024 | 3453 | 3453 |
| | | | 3449 | 3405 |
| | | | 3440 | 3355 |
| | | | 3405 | 2955 |
| | | | 2800 | |
| 95 | CTD 07 | 3460 | 3453 | 3453 |
| | | | 3449 | 3405 |
| | | | 3440 | 3355 |
| | | | 3405 | 2955 |
| | | | 2800 | |

Table 23. Overview of CTD Niskin bottle sampling.

References

Grasshoff, K.: Methods of seawater analysis, Verlag Chemie, Weinheim, 1983.

Kuhn, T., Rühlemann, C., Wiedicke-Hombach, M.: Developing a Strategy for the Exploration of Vast Seafloor Areas for Prospective Manganese Nodule Fields. Underwater Mining Institute Conference, October 15–20, Shanghai, China, 2012.

Peters K. and Moldowan M.: The Biomarker Guide, Cambridge, 2004.

Stookey, L. L.: Ferrozine - a New Spectrophotometric Reagent for Iron, Analytical Chemistry, 42, 779-8, 1970.

Winkler, L.: The determination of dissolved oxygen in water, Ber Dtsch Chem Ges 21, 2843–2857, 1888.

Acknowledgements

This work was supported by the European Union Seventh Framework Programme (FP7/2007-2013) project Managing Impacts of Deep-sea resource exploitation (MIDAS), grant agreement 603418. Additional support was provided by the UK Natural Environment Research Council as part of the National Capability Programme and the Marine Environmental Mapping Programme (MAREMAP). We thank the ships' company of RRS James Cook and personnel involved from OBE, MG and NMF at NOC for their help and support.

Appendix 1: JC120 Station list

| Event-Label | Optional Event label (Cast/Dive) | Activity / Gear Description | Location /Site | Area | Julian Day 2015 Start | UTC Date (DD-MM-YYYY) Start of deployment | UTC-time (hh:mm) Start of deployment | Latitude (N) Start of deployment | | Longitude (W) Start of deployment | | Depth , uncorrected(m) Depths with C are corrected Start of deployment |
|-------------|----------------------------------|-----------------------------|----------------------------------|----------------------------------|-----------------------|-------------------------------------------|--------------------------------------|----------------------------------|---------|-----------------------------------|---------|------------------------------------------------------------------------|
| | | | | | | | | Deg | Min | Deg | Min | |
| JC120-001 | CTD-01 | CTD | Edge of EEZ | Edge of EEZ | 15109 | 19/04/2015 | 02:41:00 | 17 | 26.0600 | 118 | 12.9100 | 3932 |
| JC120-002 | Multibeam-01 | Multibeam | From edge of EEZ to edge of APEI | From edge of EEZ to edge of APEI | 15109 | 19/04/2015 | 06:21:00 | 17 | 25.9540 | 118 | 13.2610 | |
| JC120-003 | Multibeam-02 | Multibeam | survey of APEI | survey of APEI | 15109 | 19/04/2015 | 16:45:00 | 16 | 55.8680 | 119 | 36.4960 | 4332 C |
| JC120-004 | CTD-02 | CTD | Nodule Site | | 15111 | 21/04/2015 | 00:02:00 | 16 | 53.8140 | 122 | 51.2780 | 4291 |
| JC120-005 | HybisDive-01 | Hybis | Nodule Site | | 15111 | 21/04/2015 | 03:53:15 | 16 | 53.8130 | 122 | 51.2773 | 4291 |
| JC120-005-1 | GrabSample-01 | Hybis | Nodule Site | | 15111 | 21/04/2015 | 09:45:50 | 16 | 53.4309 | 122 | 50.6078 | 4325 C |
| JC120-006 | Multibeam-03 | Multibeam | survey of APEI | | 15111 | 21/04/2015 | 13:26:00 | 16 | 49.8240 | 122 | 52.7950 | |
| JC120-007 | M75 | AutoSub6000 | Test mission | | 15112 | 22/04/2015 | 17:10:00 | 16 | 54.7960 | 122 | 59.7487 | |
| JC120-008 | Amphipod-01 | Amphipod trap lander | Deep Plain_1 | Deep Plain_1 | 15112 | 22/04/2015 | 20:30:00 | 16 | 53.4540 | 123 | 0.2660 | 4313 C |
| JC120-009 | CTD-03 | CTD | Deep Plain_1 | Deep Plain_1 | 15112 | 22/04/2015 | 22:52:00 | 16 | 54.7777 | 122 | 59.8280 | 4292 |
| JC120-010 | Megacore-01 | Megacore | Autosub patch 1 (Deep_Plain) | Deep Plain_1 | 15113 | 23/04/2015 | 02:49:50 | 16 | 54.7780 | 122 | 59.8280 | 4294 |
| JC120-011 | Multibeam-04 | Multibeam | survey of APEI | survey of APEI | 15113 | 23/04/2015 | 07:56:00 | 16 | 59.1300 | 122 | 55.6790 | 4243 C |
| JC120-012 | Megacore-02 | Megacore | Deep Plain_1 | Deep Plain_1 | 15114 | 24/04/2015 | 00:07:00 | 16 | 54.7710 | 122 | 59.8420 | 4297 |

| | | | | | | | | | | | | |
|-----------|--------------|---------------|---------------------------------|--------------|-------|------------|----------|----|---------|-----|---------|--------|
| JC120-013 | Box-01 | Boxcore | Deep Plain_1 | Deep Plain_1 | 15114 | 24/04/2015 | 04:30:00 | 16 | 54.7716 | 122 | 59.8412 | |
| JC120-014 | Box-02 | Boxcore | Ridge_1 | Ridge_1 | 15114 | 24/04/2015 | 11:31:00 | 17 | 21.5610 | 122 | 54.1850 | 4021 |
| JC120-015 | Box-03 | Boxcore | Flat_1 | Flat_1 | 15114 | 24/04/2015 | 17:05:00 | 17 | 14.4480 | 123 | 0.3978 | |
| JC120-016 | Multibeam-05 | Multibeam | | | 15114 | 24/04/2015 | 21:37:00 | 17 | 11.8240 | 123 | 3.3960 | 4197 C |
| JC120-017 | GC-01 | Gravity Corer | Autosub patch 1 (Deep_Plain) | Deep Plain_1 | 15115 | 25/04/2015 | 01:30:00 | 16 | 54.7385 | 122 | 59.8106 | 4297 |
| JC120-018 | Multibeam-06 | Multibeam | Transit to Flat_2 | | 15115 | 25/04/2015 | 05:25:00 | 16 | 55.9880 | 123 | 0.0370 | 4766 |
| JC120-019 | Megacore-03 | Megacore | Flat_2 | Flat_2 | 15115 | 25/04/2015 | 07:48:42 | 17 | 14.9351 | 123 | 1.2783 | 4156 |
| JC120-020 | Megacore-04 | Megacore | Flat_3 | Flat_3 | 15115 | 25/04/2015 | 12:08:00 | 17 | 15.0300 | 123 | 1.7500 | 4155 |
| JC120-021 | Box-04 | Boxcore | Flat_3 | Flat_3 | 15115 | 25/04/2015 | 16:11:00 | 17 | 15.0200 | 123 | 1.7600 | 4153 |
| JC120-022 | Box-05 | Boxcore | Flat_2 | Flat_2 | 15115 | 25/04/2015 | 20:25:00 | 17 | 14.9300 | 123 | 1.2800 | 4161 |
| JC120-023 | Megacore-05 | Megacore | Flat_1 | Flat_1 | 15116 | 26/04/2015 | 01:11:00 | 17 | 14.4476 | 123 | 3.9769 | 4156 |
| JC120-024 | Megacore-06 | Megacore | Flat_4 | Flat_4 | 15116 | 26/04/2015 | 05:42:00 | 17 | 13.1980 | 123 | 2.6681 | 4180 |
| JC120-025 | Megacore-07 | Megacore | Flat_1 | Flat_1 | 15116 | 26/04/2015 | 10:11:00 | 17 | 14.4229 | 123 | 3.9938 | 4158 |
| JC120-026 | M76 | AutoSub6000 | Flat_1 | Flat_1 | 15116 | 26/04/2015 | 15:15:00 | 17 | 13.8810 | 123 | 0.9390 | 4005 |
| JC120-027 | M77 | AutoSub6000 | Flat_1 | Flat_1 | 15116 | 26/04/2015 | 18:50:00 | 17 | 13.4480 | 123 | 1.2500 | 4005 |
| JC120-028 | Megacore-08 | Megacore | Trough_1 | Trough_1 | 15117 | 27/04/2015 | 01:10:00 | 17 | 13.0663 | 122 | 49.3885 | 4236 |
| JC120-029 | Box-06 | Boxcore | Trough_1 | Trough_1 | 15117 | 27/04/2015 | 05:15:00 | 17 | 13.0680 | 122 | 49.3870 | 4236 |
| JC120-030 | Multibeam-07 | Multibeam | Transit to Deep Plain | | 15117 | 27/04/2015 | 11:00:00 | 17 | 7.4900 | 122 | 53.1440 | 4194 C |
| JC120-031 | Trawl-01 | Agassiz trawl | Deep Plain_1 | Deep Plain_1 | 15117 | 27/04/2015 | 13:26:00 | 16 | 55.8780 | 123 | 1.4520 | 4270 |
| JC120-032 | Multibeam-08 | Multibeam | Transit to Trough | | 15117 | 27/04/2015 | 21:03:00 | 16 | 55.9770 | 123 | 1.4150 | 4278 C |
| JC120-033 | GC-02 | Gravity Corer | Trough_1 | Trough_1 | 15117 | 27/04/2015 | 23:43:00 | 17 | 13.0680 | 122 | 49.3910 | 4236 |

| | | | | | | | | | | | | |
|-----------|--------------|----------------------|-----------------------------------|----------|-------|------------|----------|----|---------|------|---------|--------|
| JC120-034 | Megacore-09 | Megacore | Trough_2 | Trough_2 | 15118 | 28/04/2015 | 04:29:00 | 17 | 9.4654 | 122 | 48.7850 | 4291 |
| JC120-035 | CTD-04 | CTD | Trough_1 | Trough_1 | 15118 | 28/04/2015 | 09:39:41 | 17 | 13.0685 | 122 | 49.3912 | 4008 |
| JC120-036 | Multibeam-09 | Multibeam | Transit to Flat_1 | | 15118 | 28/04/2015 | 13:14:00 | 17 | 13.1930 | 122 | 49.5160 | 4236 C |
| JC120-037 | Trawl-02 | Agassiz trawl | Flat_1 | Flat_1 | 15118 | 28/04/2015 | 15:16:00 | 17 | 14.4480 | 123 | 3.9780 | 4156 |
| JC120-038 | Multibeam-10 | Multibeam | Transit to Trough | | 15118 | 28/04/2015 | 21:34:00 | 17 | 15.4710 | 123 | 3.4050 | 4173 C |
| JC120-039 | Amphipod-02 | Amphipod trap lander | Trough_5 | Trough_5 | 15119 | 29/04/2015 | 00:03:00 | 17 | 19.2580 | 122 | 49.9570 | 4280 |
| JC120-040 | Multibeam-11 | Multibeam | Transit Trough_5 to Hybis_2 Start | | 15119 | 29/04/2015 | 00:18:00 | 17 | 18.9630 | 122 | 49.6290 | 4193 C |
| JC120-041 | HybisDive-02 | Hybis | Trough area | Trough_5 | 15119 | 29/04/2015 | 01:29:37 | 17 | 12.6088 | 122 | 48.7120 | 4260 C |
| JC120-042 | Multibeam-12 | Multibeam | Transit to Flat | | 15119 | 29/04/2015 | 15:27:00 | 17 | 16.4650 | 122 | 50.1000 | 4225 C |
| JC120-043 | M78 | AutoSub6000 | Flat | | 15119 | 29/04/2015 | 17:27:00 | 17 | 16.5590 | 123 | 4.3970 | 4397 C |
| JC120-044 | HybisDive-03 | Hybis | Ridge | | 15119 | 29/04/2015 | 23:24:49 | 17 | 19.7368 | 122 | 52.9685 | |
| JC120-045 | Multibeam-13 | Multibeam | Transit to Flat | | 15119 | 29/04/2015 | 23:22:31 | 17 | 19.7360 | 122 | 52.9690 | 4030 |
| JC120-046 | HybisDive-04 | Hybis | Flat | | 15120 | 30/04/2015 | 22:50:00 | 17 | 13.2530 | 123 | 3.6440 | 4190 |
| JC120-047 | M79 | AutoSub6000 | Flat | | 15121 | 01/05/2015 | 18:45:00 | 17 | 16.6490 | 1023 | 4.3580 | 4397 C |
| JC120-048 | Megacore-10 | Megacore | Ridge_1 | Ridge_1 | 15121 | 01/05/2015 | 23:45:00 | 17 | 21.5035 | 122 | 54.2245 | 4024 |
| JC120-049 | Megacore-11 | Megacore | Ridge_1 | Ridge_1 | 15122 | 02/05/2015 | 03:42:00 | 17 | 21.5641 | 122 | 54.1816 | 4015 C |
| JC120-050 | Box-07 | Boxcore | Ridge_2 | Ridge_2 | 15122 | 02/05/2015 | 08:53:00 | 17 | 18.8505 | 122 | 54.0536 | 4038 C |
| JC120-051 | Multibeam-14 | Multibeam | | | 15122 | 02/05/2015 | 13:35:00 | 17 | 19.4450 | 122 | 54.6480 | 4045 C |
| JC120-052 | CTD-05 | CTD | Flat_1 | Flat_1 | 15122 | 02/05/2015 | 17:58:00 | 17 | 14.3210 | 123 | 38.8500 | 4160 |
| JC120-053 | CTD-06 | CTD | Ridge_1 | Ridge_1 | 15123 | 03/05/2015 | 00:18:00 | 17 | 21.5150 | 122 | 54.1700 | 4024 |
| JC120-054 | GC-03 | Gravity Corer | Ridge_1 | Ridge_1 | 15123 | 03/05/2015 | 03:56:00 | 17 | 21.5152 | 122 | 54.1745 | 4024 |

| | | | | | | | | | | | | |
|-----------|--------------|---------------|-----------------------|----------|-------|------------|----------|----|---------|-----|---------|------|
| JC120-055 | Box-08 | Boxcore | Ridge_3 | Ridge_3 | 15123 | 03/05/2015 | 07:57:00 | 17 | 22.0172 | 122 | 53.9774 | 4028 |
| JC120-056 | Box-09 | Boxcore | Ridge_4 | Ridge_4 | 15123 | 03/05/2015 | 12:38:00 | 17 | 17.3130 | 122 | 53.0730 | 4015 |
| JC120-057 | M80 | AutoSub6000 | Ridge/Trough | | 15123 | 03/05/2015 | 18:03:00 | 17 | 16.8000 | 122 | 52.6000 | |
| JC120-058 | Megacore-12 | Megacore | Ridge_2 | Ridge_2 | 15123 | 03/05/2015 | 22:48:00 | 17 | 18.8496 | 122 | 54.0525 | 4038 |
| JC120-059 | Megacore-13 | Megacore | Ridge_3 | Ridge_3 | 15124 | 04/05/2015 | 03:22:00 | 17 | 22.0165 | 122 | 53.9771 | 4029 |
| JC120-060 | Box-10 | Boxcore | Trough_2 | Trough_2 | 15124 | 04/05/2015 | 08:45:00 | 17 | 9.4661 | 122 | 48.7837 | 4291 |
| JC120-061 | Box-11 | Boxcore | Trough_3 | Trough_3 | 15124 | 04/05/2015 | 13:00:00 | 17 | 8.7280 | 122 | 48.4950 | 4280 |
| JC120-062 | Megacore-14 | Megacore | Trough_3 | Trough_3 | 15124 | 04/05/2015 | 17:27:00 | 17 | 8.7480 | 122 | 48.5165 | 4288 |
| JC120-063 | Megacore-15 | Megacore | Trough_1 | Trough_1 | 15125 | 05/05/2015 | 00:02:00 | 17 | 13.0723 | 122 | 49.3904 | 4238 |
| JC120-064 | Megacore-16 | Megacore | Trough_4 | Trough_4 | 15125 | 05/05/2015 | 04:18:00 | 17 | 13.8737 | 122 | 48.8968 | 4263 |
| JC120-065 | Megacore-17 | Megacore | Ridge_4 | Ridge_4 | 15125 | 05/05/2015 | 08:50:00 | 17 | 17.3132 | 122 | 53.0729 | 4016 |
| JC120-066 | Megacore-18 | Megacore | Ridge_4 | Ridge_4 | 15125 | 05/05/2015 | 14:35:00 | 17 | 19.6850 | 122 | 53.2730 | 4040 |
| JC120-067 | Megacore-19 | Megacore | Trough_5 | Trough_5 | 15125 | 05/05/2015 | 17:15:00 | 17 | 17.7780 | 122 | 50.1290 | 4190 |
| JC120-068 | M81abandoned | AutoSub6000 | Ridge | | 15125 | 05/05/2015 | 21:57:00 | 17 | 18.8550 | 122 | 49.7990 | |
| JC120-069 | Box-12 | Boxcore | Trough_4 | Trough_4 | 15125 | 05/05/2015 | 23:45:00 | 17 | 13.8732 | 122 | 48.8985 | 4264 |
| JC120-070 | Box-13 | Boxcore | Trough_5 | Trough_5 | 15126 | 06/05/2015 | 04:47:00 | 17 | 17.7800 | 122 | 50.1308 | 4238 |
| JC120-071 | Multibeam-15 | Multibeam | Transit to Flat | | 15126 | 06/05/2015 | 08:58:00 | 17 | 17.5600 | 122 | 50.1650 | 4266 |
| JC120-072 | Box-14 | Boxcore | Flat_4 | Flat_4 | 15126 | 06/05/2015 | 10:30:00 | 17 | 13.1998 | 123 | 2.6689 | 4179 |
| JC120-073 | Box-15 | Boxcore | Flat_5 | Flat_5 | 15126 | 06/05/2015 | 15:00:00 | 17 | 14.3900 | 123 | 1.5900 | 4160 |
| JC120-074 | GC-04 | Gravity Corer | Flat_1 | Flat_1 | 15126 | 06/05/2015 | 20:04:00 | 17 | 14.4480 | 123 | 3.9790 | 4162 |
| JC120-075 | Megacore-20 | Megacore | Flat_5 | Flat_5 | 15127 | 07/05/2015 | 00:06:00 | 17 | 14.3754 | 123 | 1.6038 | 4157 |
| JC120-076 | Megacore-21 | Megacore | Flat_3 | Flat_3 | 15127 | 07/05/2015 | 04:16:00 | 17 | 15.0308 | 123 | 1.7545 | 4154 |
| JC120-077 | Box-16 | Boxcore | Ridge-5 | Ridge_5 | 15127 | 07/05/2015 | 09:37:00 | 17 | 19.6855 | 122 | 53.2744 | 4017 |
| JC120-078 | M81 | AutoSub6000 | Ridge | | 15127 | 07/05/2015 | 15:18:00 | 17 | 15.8820 | 122 | 49.8300 | |
| JC120-079 | HybisDive-05 | Hybis | Across Ridge | | 15127 | 07/05/2015 | 21:00:00 | 17 | 17.6210 | 122 | 48.1283 | 4156 |
| JC120-080 | Multibeam-16 | Multibeam | Transit to Deep Plain | | 15128 | 08/05/2015 | 23:27:00 | 17 | 16.8430 | 122 | 52.8510 | 4014 |

| | | | | | | | | | | | | |
|-----------|--------------|---------------|--------------------------------|--------------|-------|------------|----------|----|---------|-----|---------|--------|
| JC120-081 | GC-05 | Gravity Corer | Deep Plain_1 | Deep Plain_1 | 15129 | 09/05/2015 | 01:58:00 | 16 | 54.7901 | 122 | 59.8171 | 4290 |
| JC120-082 | Box-17 | Boxcore | Deep Plain 2 | Deep Plain_2 | 15129 | 09/05/2015 | 06:02:00 | 16 | 54.1681 | 123 | 0.9585 | 4290 |
| JC120-083 | Box-18 | Boxcore | Deep Plain 3 | Deep Plain_3 | 15129 | 09/05/2015 | 10:42:00 | 16 | 54.4101 | 123 | 1.3855 | 4265 |
| JC120-084 | Megacore-22 | Megacore | Deep Plain 3 | Deep Plain_3 | 15129 | 09/05/2015 | 15:05:00 | 16 | 54.4110 | 123 | 1.3860 | 4265 |
| JC120-085 | Multibeam-17 | Multibeam | Transit Deep plain to Trough | | 15129 | 09/05/2015 | 18:56:00 | 16 | 55.0420 | 123 | 1.1220 | 4294 C |
| JC120-086 | M82 | AutoSub6000 | Trough | | 15129 | 09/05/2015 | 21:28:00 | 17 | 18.6930 | 122 | 49.8780 | |
| JC120-087 | M83 | AutoSub6000 | Trough | | 15130 | 10/05/2015 | 07:26:00 | 17 | 16.8100 | 122 | 52.5550 | |
| JC120-088 | Multibeam-18 | Multibeam | Transit Trough to volcano | | 15130 | 10/05/2015 | 11:48:00 | 17 | 15.1060 | 122 | 43.5320 | 4168 C |
| JC120-089 | HybisDive-06 | Hybis | Volcano | Volcano | 15130 | 10/05/2015 | 15:29:00 | 16 | 51.9443 | 122 | 41.2697 | 4119 |
| JC120-090 | Megacore-23 | Megacore | Volcano | Volcano | 15131 | 11/05/2015 | 01:25:00 | 16 | 52.3877 | 122 | 41.9125 | 3419 |
| JC120-091 | Multibeam-19 | Multibeam | Transit Volcano to deep plain | | 15131 | 11/05/2015 | 04:53:00 | 16 | 52.4910 | 122 | 42.1620 | |
| JC120-092 | Megacore-24 | Megacore | Deep Plain 2 | Deep Plain_2 | 15131 | 11/05/2015 | 07:02:00 | 16 | 54.1516 | 123 | 0.9716 | 4291 |
| JC120-093 | Multibeam-20 | Multibeam | Transit Deep plain to Trough | | 15131 | 11/05/2015 | 11:20:00 | 16 | 54.4000 | 123 | 0.7444 | 4300 C |
| JC120-094 | Multibeam-21 | Multibeam | Transit Trough to volcano | | 15131 | 11/05/2015 | 14:50:00 | 17 | 13.8340 | 122 | 48.3900 | 4221 C |
| JC120-095 | CTD-07 | CTD | Volcano | Volcano | 15131 | 11/05/2015 | 17:21:00 | 16 | 52.2990 | 122 | 41.6360 | 3460 |
| JC120-096 | Multibeam-22 | Multibeam | Transit to edge of APEII | | 15131 | 11/05/2015 | 20:41:00 | 16 | 52.0180 | 122 | 40.6810 | 3770 C |
| JC120-097 | Multibeam-23 | Multibeam | Transit from APEII to UK claim | | 15132 | 12/05/2015 | 00:51:00 | 16 | 30.4190 | 122 | 1.6410 | 3928 C |
| JC120-098 | CTD-08 | CTD | UK claim | UK-claim | 15133 | 13/05/2015 | 11:08:00 | 13 | 28.5002 | 116 | 44.9997 | 4217 |
| JC120-099 | Multibeam-22 | Multibeam | UK claim | UK-claim | 15133 | 13/05/2015 | 15:06:00 | 13 | 28.5470 | 116 | 45.0170 | 4216 C |

| | | | | | | | | | | | | |
|-----------|--------------|---------------|----------------------------|----------|-------|------------|----------|----|---------|-----|---------|--------|
| JC120-100 | M84 | AutoSub6000 | UK claim | UK-claim | 15133 | 13/05/2015 | 22:10:00 | 13 | 29.8200 | 116 | 37.3000 | |
| JC120-101 | GC-06 | Gravity Corer | UK claim | UK-claim | 15134 | 14/05/2015 | 06:11:00 | 13 | 27.7833 | 116 | 36.5070 | 4108 |
| JC120-102 | Megacore-25 | Megacore | UK claim | UK-claim | 15134 | 14/05/2015 | 09:52:00 | 13 | 27.8121 | 116 | 36.4965 | 4108 |
| JC120-103 | M85 | AutoSub6000 | UK claim | UK-claim | 15134 | 14/05/2015 | 15:49:00 | 13 | 29.6101 | 116 | 37.3840 | 3996 |
| JC120-104 | Trawl-03 | Agassiz trawl | UK claim | UK-claim | 15134 | 14/05/2015 | 21:20:00 | 13 | 30.0000 | 116 | 35.5000 | 4130 |
| JC120-105 | Megacore-26 | Megacore | UK claim | UK-claim | 15135 | 15/05/2015 | 04:29:00 | 13 | 27.8126 | 116 | 36.4958 | 4113 |
| JC120-106 | Megacore-27 | Megacore | UK claim | UK-claim | 15135 | 15/05/2015 | 08:23:00 | 13 | 27.8015 | 116 | 36.4890 | 4108 |
| JC120-107 | Box-19 | Boxcore | UK claim | UK-claim | 15135 | 15/05/2015 | 12:28:00 | 13 | 27.8123 | 116 | 36.4942 | 4113 |
| JC120-108 | Multibeam-23 | Multibeam | UK claim | UK-claim | 15135 | 15/05/2015 | 16:41:00 | 13 | 27.9380 | 116 | 36.4370 | 4112 C |
| JC120-109 | Multibeam-24 | Multibeam | UK claim to potential APEI | | 15135 | 15/05/2015 | 22:23:00 | 13 | 25.8640 | 116 | 34.9700 | 4170 C |
| JC120-110 | HybisDive-07 | Hybis | Potential APEI | | 15136 | 16/05/2015 | 16:32:00 | 14 | 57.0010 | 113 | 41.2000 | |
| JC120-111 | Multibeam-25 | Multibeam | Potential APEI to EEZ | | 15136 | 16/05/2015 | 22:57:00 | 14 | 57.1927 | 113 | 41.9010 | 3918 C |