



**British
Geological Survey**

NATURAL ENVIRONMENT RESEARCH COUNCIL

A geological model of the Chalk of East Kent

Volume 1 of 2 : Report

Integrated Geoscience Surveys (South) Programme

Commissioned Report CR/04/092N



BRITISH GEOLOGICAL SURVEY

COMMISSIONED REPORT CR/04/092N

A geological model of the Chalk of East Kent

Volume 1 of 2 : Report

D T Aldiss, J R Bloomfield, D K Buckley, S K Doran, D J Evans, P
M Hopson, K R Royse and M A Woods

The National Grid and other
Ordnance Survey data are used
with the permission of the
Controller of Her Majesty's
Stationery Office.
Ordnance Survey licence number
GD 272191/1999

Key words

Kent; Great Stour; North Downs;
Chalk; Palaeogene; structure;
geological model.

Front cover

Seaford Chalk in Denne's Chalk
Pit, Canterbury [TR148 566], in
1960. Three courses of flint are
offset by small faults. Brown
silty sand partly chokes the
fissures and has also washed
along the flint beds, where it
infills irregular cavities.

BGS Photograph A09664

Bibliographical reference

ALDISS, D T, BLOOMFIELD, J R,
BUCKLEY, D K, DORAN, S K,
EVANS, D J, HOPSON, P M,
ROYSE, K R AND WOODS, M A.
2004. A geological model of the
Chalk of East Kent. Volume 1 of
2: Report. *British Geological
Survey Commissioned Report*,
CR/04/092. 97pp

“This report contains commercially sensitive data from Folkestone and Dover Water Services, Mid Kent Water and Southern Water. Any person or organisation who has a copy of this report should not make it available to others without written permission from Folkestone and Dover Water Services, Mid Kent Water, Southern Water and the Environment Agency.”

Volume 2 of this report comprises an Appendix of geophysical log suites with hydrogeological interpretations

BRITISH GEOLOGICAL SURVEY

The full range of Survey publications is available from the BGS Sales Desks at Nottingham and Edinburgh; see contact details below or shop online at www.thebgs.co.uk

The London Information Office maintains a reference collection of BGS publications including maps for consultation.

The Survey publishes an annual catalogue of its maps and other publications; this catalogue is available from any of the BGS Sales Desks.

The British Geological Survey carries out the geological survey of Great Britain and Northern Ireland (the latter as an agency service for the government of Northern Ireland), and of the surrounding continental shelf, as well as its basic research projects. It also undertakes programmes of British technical aid in geology in developing countries as arranged by the Department for International Development and other agencies.

The British Geological Survey is a component body of the Natural Environment Research Council.

Keyworth, Nottingham NG12 5GG

☎ 0115-936 3241 Fax 0115-936 3488
e-mail: sales@bgs.ac.uk
www.bgs.ac.uk
Shop online at: www.thebgs.co.uk

Murchison House, West Mains Road, Edinburgh EH9 3LA

☎ 0131-667 1000 Fax 0131-668 2683
e-mail: scotsales@bgs.ac.uk

London Information Office at the Natural History Museum (Earth Galleries), Exhibition Road, South Kensington, London SW7 2DE

☎ 020-7589 4090 Fax 020-7584 8270
☎ 020-7942 5344/45 email: bgs london@bgs.ac.uk

Forde House, Park Five Business Centre, Harrier Way, Sowton, Exeter, Devon EX2 7HU

☎ 01392-445271 Fax 01392-445371

Geological Survey of Northern Ireland, 20 College Gardens, Belfast BT9 6BS

☎ 028-9066 6595 Fax 028-9066 2835

Maclea Building, Crowmarsh Gifford, Wallingford, Oxfordshire OX10 8BB

☎ 01491-838800 Fax 01491-692345

Parent Body

Natural Environment Research Council, Polaris House, North Star Avenue, Swindon, Wiltshire SN2 1EU

☎ 01793-411500 Fax 01793-411501
www.nerc.ac.uk

Acknowledgements

This report was produced as part of a project funded by the Environment Agency, and supported by Mid-Kent Water, Southern Water and (on behalf of Folkestone and Dover Water Services) Veolia Water.

The project was also assisted by the provision of water borehole records by these four organisations, and the authors would like to thank in particular Michael Cheetham (Environment Agency), Lee Dance (Mid-Kent), Trevor Muten and Jon Ticehurst (Southern Water), and Lucy Lytton and Jessica Randle (Veolia Water).

“This report contains commercially sensitive data from Folkestone and Dover Water Services, Mid Kent Water and Southern Water. Any person or organisation who has a copy of this report should not make it available to others without written permission from Folkestone and Dover Water Services, Mid Kent Water, Southern Water and the Environment Agency.”

Contents

Acknowledgements	i
Contents	ii
Summary	vi
1 Introduction	1
2 Data sources and data acquisition	2
2.1 1:50 000 scale geological maps and other publications	2
2.2 Field slips and standards	3
2.3 Borehole Logs (Lithological)	3
2.4 Borehole Logs (Geophysical).....	4
2.5 Seismic data.....	4
2.6 Biostratigraphical data.....	4
2.7 Topographic maps and digital terrain models	5
3 The Chalk Group	5
3.1 Introduction	5
3.2 Grey Chalk Subgroup	6
3.2.1 West Melbury Marly Chalk Formation.....	6
3.2.2 Zig Zag Chalk Formation.....	7
3.3 White Chalk Subgroup	8
3.3.1 Holywell Nodular Chalk Formation.....	9
3.3.2 New Pit Chalk Formation.....	10
3.3.3 Lewes Nodular Chalk Formation	11
3.3.4 Seaford Chalk Formation	13
3.3.5 Margate Chalk Member (Newhaven Chalk Formation)	14
4 The Palaeogene	15
4.1 Thanet Sand Formation	15
4.2 Upnor Formation (Lambeth Group)	15
4.3 Harwich Formation (Thames Group)	16
4.4 London Clay Formation (Thames Group).....	16
5 Superficial Deposits	16
6 Geological Modelling	17
6.1 The modelling process.....	17
6.2 Mapping the new Chalk lithostratigraphy	18
6.2.1 General procedure	18
6.2.2 Base of West Melbury Marly Chalk Formation.....	19

6.2.3	Base of Zig Zag Chalk Formation.....	20
6.2.4	Base of Holywell Nodular Chalk Formation.....	20
6.2.5	Base of New Pit Chalk Formation.....	21
6.2.6	Base of Lewes Nodular Chalk Formation.....	22
6.2.7	Base of Seaford Chalk Formation.....	22
6.2.8	Base of Margate Chalk Member.....	23
6.2.9	Base of Palaeogene.....	24
6.3	The geophysical characterisation of the Chalk Group in East Kent.....	24
6.3.1	Base of Chalk Group.....	24
6.3.2	West Melbury Marly Chalk Formation.....	24
6.3.3	Zig Zag Chalk Formation.....	25
6.3.4	Holywell Nodular Chalk Formation.....	25
6.3.5	New Pit Chalk Formation.....	25
6.3.6	Lewes Nodular Chalk Formation.....	25
6.3.7	Seaford Chalk Formation.....	26
6.3.8	Newhaven Chalk Formation (Margate Chalk Member).....	26
6.3.9	Top of Chalk Group.....	27
7	Structure.....	27
7.1	General considerations.....	27
7.2	Regional structure.....	28
7.3	Regional dip and folding.....	29
7.3.1	Regional dip.....	29
7.3.2	Strike-parallel folds.....	30
7.3.3	Dip-parallel folds.....	30
7.4	Faulting and fracturing.....	31
7.4.1	Fault patterns.....	31
7.4.2	Stour Valley Fault Zone.....	31
7.4.3	Other NE-SW and NNE-SSW faulting and fracturing.....	32
7.4.4	NW-SE faulting and fracturing.....	33
7.4.5	NNW-SSE faulting and fracturing.....	34
7.4.6	Faulting and fracturing in the Isle of Thanet.....	34
7.4.7	Slope aspect analysis.....	34
7.4.8	Faulting in the Alkham valley.....	38
8	Some hydrogeological characteristics of the Chalk.....	40
8.1	Introduction.....	40
8.2	Interpretation of water flow horizons at depth from geophysical logging.....	41
8.2.1	Geophysical log measurements.....	41
8.2.2	Sources of geophysical logging data used.....	43

8.2.3	Identification of groundwater flow horizons at depth.....	44
8.2.4	Conceptual model of groundwater movement in the Chalk aquifer from geophysical logging observations.....	45
8.2.5	Hydrogeological cross-sections.....	47
8.3	Bourne streams, springs and sink holes.....	48
8.3.1	The Nail Bourne (including the Barham Valley).....	48
8.3.2	Alkham Valley	49
8.3.3	Petham Valley	50
8.3.4	Other springs	50
9	Conclusions	50
10	References	54

FIGURES

Figure 1:	Location and outline geology of the project area	59
Figure 2:	Bedrock geology of East Kent	60
Figure 3:	Location of seismic survey lines	61
Figure 4:	Resistivity log and stratigraphical interpretation of the St. Margarets at Cliffe (C1 Seaview) Borehole	62
Figure 5:	Resistivity log and stratigraphical interpretation for the Dover 1 Aycliff (cored) Borehole	63
Figure 6:	Resistivity log and stratigraphical interpretation of the Lower Venson Farm (cored) Borehole	64
Figure 7:	Correlation of lithostratigraphical units and marker horizons between key boreholes in East Kent	65
Figure 8:	Correlation of lithostratigraphical units between key boreholes in East Kent using OD as a common datum	66
Figure 9:	Resistivity log and stratigraphical interpretation of the Boughton Pumping Station Borehole	67
Figure 10:	Resistivity log and stratigraphical interpretation of the Reculver 1 Borehole	68
Figure 11:	Resistivity log and stratigraphical interpretation of the Reculver 2 Borehole	69
Figure 12:	Bedrock geology of North Kent and East Kent	70
Figure 13:	Slope aspect analysis of East Kent	71
Figure 14:	Valley lineaments in East Kent: subdivision by ‘geological’ criteria	72
Figure 15:	Valley lineaments in East Kent: subdivision by ‘topographic’ criteria	73
Figure 16:	Valley lineaments in the Chalk of East Kent – ‘geological’ subdivision	74
Figure 17:	Valley lineaments in the Chalk of East Kent – ‘topographic’ subdivision	76
Figure 18:	Typical geophysical log profiles of Chalk formations showing named horizons, Boughton ABH1	77

- Figure 19: Comparison of gamma ray logs of Palaeogene and Chalk formations, Hoath and Reculver boreholes 78
- Figure 20: Geophysical logs showing well bore flow of groundwater between fissured horizons and entry of brackish water, Dover-Deal borehole C6 79
- Figure 21: Fluid logs showing upflow of groundwater from fissured horizons in Lewes Chalk to wellscreen opposite Seaford Chalk 80
- Figure 22: Fluid log profile changes in a coastal borehole caused by changes in sea tide, Dover-Deal borehole C3 81
- Figure 23: Fluid logs recorded whilst pumping, Reculver borehole 1 82
- Figure 24: Comparison of flowmeter logging, matrix permeability and packer test bulk permeability measurements to characterise horizons of fluid movement within the Chalk aquifer (Totford borehole, Hampshire) 83
- Figure 25: Scale cross-section SW-NE showing north-easterly dip of strata, shallower slope of water table and high fluid SEC in the Chalk aquifer from two sources 84
- Figure 26: Scale hydrogeological cross-section, Dover-Deal C2-C6, East Kent, based on geophysical logging data 85
- Figure 27: Scale hydrogeological cross-section Stodmarsh –Reculver, based on geophysical logging data 86

TABLES

- Table 1: Correlation of biostratigraphical and lithostratigraphical classification schemes for the Chalk of southern England 87
- Table 2: Correlation of stratigraphic terminology: marker beds 88
- Table 3: Relative position of marker beds near the base of the Lewes Chalk in Kent 89
- Table 4: Valley lineaments; rose diagram statistics 90
- Table 5: Summary of gamma ray and resistivity log measurement statistics for the Chalk units penetrated in selected boreholes in East Kent 91
- Table 6: Summary of water inflow positions interpreted from fluid log data of selected Chalk boreholes, East Kent Project 92
- Table 7: Depth to estimated base of more rapid groundwater circulation interpreted from fluid temperature log profiles in selected East Kent Chalk boreholes 97

Volume 2 of this report comprises an Appendix of geophysical borehole logs with hydrogeological interpretations.

Summary

This report describes the geological modelling of the Chalk in the North Downs of East Kent, within the catchment of River Great Stour and eastwards to the coast, including the Isle of Thanet. This work was funded by the Environment Agency to support investigations of the local hydrogeology and thereby to enhance catchment management.

The whole area is underlain by the Upper Cretaceous Chalk Group, with the Palaeogene succession of the Thanet Sand Formation, the Lambeth Group and the Thames Group overlying it in the northern and central eastern parts.

The project included a desk study revision of the Chalk of the North Downs, using the new Chalk lithostratigraphy. The revisions to the geology are shown on the 1:50 000 scale geological map which accompanies this report. Together with evidence from boreholes and from seismic surveys, the new outcrop patterns have been incorporated into a geological model, using both computer software (EarthVision) and manual methods.

The introduction describes the background to the project. The second chapter describes the sources for the data used in the model: published and unpublished geological maps, borehole records (both lithological and geophysical), seismic surveys, biostratigraphic records, digital topographic information, and the published literature.

Each Chalk formation present in the area is then briefly described in the third chapter, noting its relationship to the older lithostratigraphic divisions, and to biostratigraphic zones. The local Chalk succession extends from the base of the Chalk Group to the Newhaven Chalk Formation, here represented by the Margate Chalk Member. Evidence for the thickness of each formation is reviewed.

The early Palaeogene formations (the Thanet Sand, Upnor, Harwich and London Clay formations) are also briefly described (Chapter 4) and the local superficial deposits mentioned, with references to detailed descriptions (Chapter 5). Apart from minor adjustments to the outcrop of the basal Palaeogene surface, no revision of these formations was done for this study.

An account of the processes that led to the generation of the geological model includes notes on the criteria used to subdivide the Chalk according to the new lithostratigraphy, both at outcrop and in geophysical logs (Chapter 6).

A discussion of the structure (Chapter 7) starts with observations on the kinds of influence exerted on the Chalk by tectonic structures, and on the difficulties of specifically identifying faults in the Chalk. The three classes of fault shown on the new geological map of East Kent which accompanies this report are explained. Short summaries of relevant regional studies are given before the patterns of local folding and faulting, both subparallel to strike and subparallel to dip, are described.

The Chalk generally dips at 1° or less, with steeper dips occurring locally in the vicinity of faults and folds. The dip direction is typically to the north-north-east (N025°) but eastwards, near the coast, the dip direction is commonly more towards the north-east (N040°). In some areas in the west, it turns to a more northerly direction. Strike directions also turn to an east-west orientation near the edge of the Palaeogene outcrop between Wingham and Eastry, continuing northwards through the Richborough Syncline and the complementary Thanet Anticline into the Isle of Thanet.

Several smaller WNW-ESE-trending folds occur close to the coast between Folkestone and Dover, including the Dover Anticline.

Other than in the Isle of Thanet, most fault orientations in East Kent can be treated in two broad groups: NE-SW (including a subset oriented NNE-SSW) and WNW-ESE. In addition, NNW-SSE faults occur locally, particularly in a zone to the west of Canterbury. Fault trends on the Isle of Thanet are less clearly defined, including E-W, NW-SE and N-S elements.

The newly recognised Stour Valley Fault Zone occupies a NE-SW-trending linear zone, between about 3 km and 5 km wide, along part of the Great Stour valley. This marks a considerable change in structural style between the Chalk of North Kent and the Chalk of East Kent.

Section 7 is completed with a presentation of the results of slope aspect analysis of the linear valleys in the project area, and a discussion of the evidence for faulting in part of the Alkham valley.

Some geological factors influencing the local hydrogeology are noted in Chapter 8, followed by a general account of the hydrogeological interpretation of geophysical borehole logs from the project area. The hydrogeological interpretations of log suites from individual boreholes are given in a separate Appendix. Possible stratigraphic and structural controls of some local surface hydrogeological features: bourne streams, springs and swallow holes, are also noted.

The principal conclusions are summarised in Chapter 9.

Chapter 10 is a reference list for the report.

The Figures and Tables are presented at the end of the report.

An separate Appendix includes 36 suites of geophysical borehole logs from 34 water boreholes in the project area. The logs have been interpreted for the likely position of water inflow horizons.

1 Introduction

The Environment Agency (EA) requested the British Geological Survey (BGS) to provide information on the bedrock geology of part of East Kent, to support investigations of the local hydrogeology and the formulation of catchment management plans.

This report describes the stratigraphy and structure of the Upper Cretaceous Chalk Group, with reference to a three dimensional (3D) geological model. The overlying early Palaeogene deposits and superficial (drift) deposits are described briefly.

The area described in this report encompasses the Chalk outcrop within the catchment of the River Great Stour, east of National Grid Easting 600 000, extending east and north to the coast and so including the Isle of Thanet (Figure 1). The North Downs escarpment forms the most prominent topographical feature. This is formed by the Chalk Group, which underlies most of the area (Figure 2). The Chalk dips gently generally north-north-eastwards away from the scarp, progressively disappearing beneath a cover of Palaeogene and Quaternary deposits north of a line between Canterbury and Sandwich. The Palaeogene deposits are preserved within an asymmetric east-west trending, westwards-plunging fold pair, which brings the Chalk back to the surface in the north of the area, so forming the Isle of Thanet.

The main Chalk outcrop is divided in two by a weakly defined, subparallel, secondary escarpment (Figure 2). This bounds the north-eastern side of the Dour Valley at Dover, continuing north-westwards as far as the Barham Downs at Bridge. It is there offset to the south-west, continuing through the Chartham Downs to the River Great Stour.

Traditionally, the Chalk was divided into three units, effectively of formation status: the Lower Chalk, the Middle Chalk and the Upper Chalk. Named members or beds within these units, such as the Glauconitic Marl, the Melbourn Rock and the Chalk Rock (which occur at the respective bases of the three traditional units) were widely recognised (Table 1). However, following work by Mortimore (1986a, fig. 3) and by Bristow et al. (1995), it was found that a more detailed lithostratigraphic subdivision of the Chalk was possible (Bristow et al., 1997). Following further discussion, it was proposed that the Chalk Group be divided into an older Grey Chalk Subgroup and a younger White Chalk Subgroup, the boundary between being placed at the base of the Plenus Marls, slightly below the base of the traditional Middle Chalk (Rawson et al., 2001). Each subgroup was further divided into formations (Table 1) which now form the basis for the mapping of the Chalk across southern England, and which are used in this study. The formations are described in Section 3. Brief descriptions of the overlying Palaeogene formations are given in Section 4, and the superficial (Quaternary) deposits mentioned briefly in Section 5, in both cases with references to more detailed published descriptions.

The correspondence of biostratigraphic zones with the lithostratigraphic scheme used here is shown in Tables 1 and 2, and described by Rawson (1992) and Mortimore et al. (2001).

A 3D geological model was constructed digitally using datasets from seismic surveys, borehole logs (both lithological and geophysical), digital topographic information, palaeontological records, geological maps and geological field records, as outlined in Section 2. New geological boundaries subdividing the Chalk outcrop according to modern lithostratigraphy (Section 3) were compiled, using the criteria outlined in Section 6. The bedrock geology of the area, so derived, is also shown on the 1:50 000 scale geological map which accompanies this report. This new linework was used, together with the other datasets, to compile a 3D computer model from which gridded surfaces and cross sections could be generated.

The structure of the Chalk of East Kent is relatively complex, compared with North Kent and with most other parts of the Chalk outcrop. This complexity arises in part from local folding but mainly from the extensive development of faults in several intersecting sets. Section 7 introduces

a description of the local tectonic structure of the Chalk by considering some of the general controls on the development of folds and faults, and problems associated with recognising them in the Chalk. It explains the three classes of fault shown on the new geological map of East Kent which accompanies this report. The main findings of some previous investigations of the structure in the region, including interpretations of the main tectonic controls on fault patterns, are then summarised.

The distribution of folding in the project area is described in Section 7.3, mentioning both folds recognised during the present project, and previously described folding for which no evidence was seen. Section 7.4 deals with faulting and fracturing. Section 7.4.1 describes the general pattern of faulting; Section 7.4.2 describes the evidence for a newly recognised fault zone aligned with the Great Stour Valley: this includes faults of several different orientations; Sections 7.4.3 to 7.4.6 deal with other faulting on three main trends, and with faults in the Isle of Thanet. Section 7.4.7 discusses the findings of an investigation of linear valleys in the project area, by slope aspect analysis, as a guide to patterns of faulting and fracturing. Section 7.4.8 discusses evidence for faulting in part of the Alkham valley near Alkham and Drellingore.

Section 8 is mostly devoted to the hydrogeological interpretation of geophysical logs suites, with some observations of likely structural and stratigraphic controls on the location of some springs and swallow holes.

A similar report (Farrant and Aldiss, 2002) describes the Chalk of North Kent (between the River Medway and the River Great Stour). A companion report discusses the Palaeogene deposits of North Kent, and assesses the possibilities for improving the geological understanding of that part of the succession (Aldiss and Farrant, 2002).

2 Data sources and data acquisition

2.1 1:50 000 SCALE GEOLOGICAL MAPS AND OTHER PUBLICATIONS

Five 1:50 000 scale geological maps published by the BGS cover the project area (Figure 1). These maps are essentially reprints of the 'New Series' one-inch (1:63 360) sheets transferred onto new 1:50 000 scale base maps with only minor, if any, revision.

The maps all use the traditional three-fold subdivision of the Chalk: none show the new lithostratigraphic scheme developed for the Chalk over the last ten years (Sections 1 & 3). The relationship between the geological boundaries shown on the published maps with those newly compiled for the map which accompanies this report is described in relevant parts of Section 3. In summary, the base of the Chalk remains at the base of the Glauconitic Marl; the base of the Holywell Chalk is slightly lower than the base of the Middle Chalk; and the base of the Lewes Chalk is significantly lower than the base of the Upper Chalk (Table 1).

The classification of the Palaeogene deposits used on the published maps has also been revised (Ellison et al., 1994).

Sheet 273 (Faversham) is based on six inch (1:10 560 scale) surveys in 1937-46 and republished in 1974 with only minor revision. The memoir was published in 1981 (Holmes, 1981).

Sheet 274 (Ramsgate) is based on six-inch surveys in 1938 and 1961-62 and published in 1967. It was reprinted with minor additions at 1:50 000 scale in 1980. The memoir (which also describes the Dover district) was published in 1988 (Shephard-Thorn, 1988).

Sheet 289 (Canterbury) is based on six inch surveys in 1938-55 and was republished in 1982 with only minor revision. The memoir (which also describes the Folkestone and Dover district) was published in 1966 (Smart et al., 1966).

Sheet 290 (Dover) is based on six inch surveys in 1951, 1953 and 1960-61 and was published in 1966. It was reprinted at 1:50 000 scale in 1977. The memoir (which also describes the Ramsgate district) was published in 1988 (Shephard-Thorn, 1988).

Sheet 305 and 306 (Folkestone and Dover) is based on six inch surveys between 1951 and 1956 and was published in 1966. It was reprinted at 1:50 000 scale in 1974. The memoir (which also describes the Canterbury district) was published in 1966 (Smart et al., 1966).

Other published geological literature which was consulted is noted where relevant, and listed in Section 10.

2.2 FIELD SLIPS AND STANDARDS

The area was geologically surveyed at 1:10 560 scale. Much lithostratigraphic and biostratigraphic data are recorded on the 'field slips' (copies of the relevant 1:10 560 scale Ordnance Survey topographic maps annotated by the field geologists during the field surveys). The data density and quality are variable, depending on the degree of exposure and on the surveyor.

Some of these large-scale maps show contours at a vertical interval of only one hundred feet [30.5 m]. This significantly constrains the precision with which the geological boundaries could be plotted.

Fair-drawn copies of the geological maps were compiled at 1:10 560. These maps, known as 'standards', are also annotated with local geological information. The 1:63 360 scale geological maps were compiled from the standards.

The field slips and standards are held in the National Geological Records Centre (NGRC) at BGS Keyworth.

2.3 BOREHOLE LOGS (LITHOLOGICAL)

Records of about 3000 boreholes in the East Kent area are held in the National Geological Records Centre. These records are of variable age and quality and many lack useful lithological (or lithostratigraphical) information, the descriptions being too vague, imprecise or inaccurate. Furthermore, in many cases, close examination suggests that the borehole location details are unreliable. Some 300 borehole logs were found to provide useful information about at least one stratigraphic boundary (Section 6.1).

Where possible, the level of each stratigraphic boundary recorded in these logs was determined and converted to elevation with respect to Ordnance Datum. In some cases only the level of the top Chalk surface could be determined. None of the boreholes had been previously interpreted using the new Chalk lithostratigraphy.

As discussed in Section 3.3.1, where borehole records note a depth for the base of the Middle Chalk, a standard factor of 2.5 m was added to derive a value for the depth of the base of the Holywell Chalk.

Similarly, where borehole records note a depth for the base of the Upper Chalk, a standard factor of 16 m was added to derive a value for the depth of the base of the Lewes Chalk (Section 3.3.3).

In order to constrain the deeper levels of the 3D geological model, 'phantom data points' were introduced in some areas. Borehole logs intersecting the top of the Chalk beneath the Palaeogene were extrapolated downwards to the depth to the base of each of the new Chalk formations, using an estimated thickness for each. Although this is better than no data, it should be emphasised that the thickness of each unit is known to vary somewhat across the area, and so these 'phantom data points' are correspondingly uncertain.

2.4 BOREHOLE LOGS (GEOPHYSICAL)

Geophysical borehole logs (natural gamma and resistivity) were collated from BGS archives, the Environment Agency and the local water companies. These logs were interpreted in terms of the new Chalk stratigraphic units. The stratigraphic interpretation of the boreholes is based on work by Mortimore and Pomerol (1987) and Murray (1986) and is described more fully in Sections 6.3 and 8.1, and by Woods (2001; 2002). Sources of geophysical logs are discussed further in Section 8.2.

The attention of the reader is drawn to the confidentiality clause on the cover of this report:

“This report contains commercially sensitive data from Folkestone and Dover Water Services, Mid Kent Water and Southern Water. Any person or organisation who has a copy of this report should not make it available to others without written permission from Folkestone and Dover Water Services, Mid Kent Water, Southern Water and the Environment Agency.”

About 110 geophysical borehole logs were found to provide useful information about at least one stratigraphic boundary. Lithological borehole logs were available for some of these boreholes.

A total of about 380 boreholes provided seemingly reliable stratigraphic data, from either lithological or geophysical logs, or both (See also Section 6.1).

2.5 SEISMIC DATA

The location of seismic data used in the project is shown in Figure 3. The seismic surveys were carried out for hydrocarbon exploration of the Weald Basin in the late 1970s and early 1980s, or for investigation of the North Kent coalfield in the 1980s. Data from seismic surveys that occur entirely within the area has been processed and interpreted for the respective bases of the Upper Chalk, the Middle Chalk and the Lower Chalk. These seismic picks represent a reasonable approximation to the bases of the Lewes, Holywell and West Melbury Chalk formations (Section 6.1). Some of the hydrocarbons exploration surveys (not shown in Figure 3) extend into the project area only near the south-western edge, and it was considered that their inclusion would not be cost-effective.

2.6 BIOSTRATIGRAPHICAL DATA

Where possible, biozonal information in both published and unpublished records, together with any associated lithological observations, have been used to infer the lithostratigraphic unit (or units) occurring at each locality. In some cases, it is possible to infer the relative position within a formation (e.g. ‘higher part of Lewes Chalk’). However, it is possible that a modern biostratigraphic assessment of the fossil material collected from some localities would reach a different conclusion.

Moreover, the biostratigraphic data is quite variable in distribution. There is a wealth of data points for the Lewes Chalk, Seaford Chalk and Margate Chalk formations, and a relative lack of data for the remainder of the Chalk succession. The New Pit Chalk Formation in particular has only a few data points for the entire area. Furthermore, much of the dip slope is covered by superficial or Palaeogene deposits and so there are very few exposures of the Chalk other than in old pits and quarries along the sides of the valleys.

Biostratigraphic maps of the Chalk published in the Canterbury and the Ramsgate and Dover Memoirs are discussed in Section 6.

2.7 TOPOGRAPHIC MAPS AND DIGITAL TERRAIN MODELS

Ordnance Survey 1:10 000 scale topographic maps, including contours at a five metre vertical interval, and Digital Terrain Models were used as an aid to compiling the new Chalk linework and to identify possible fault zones and fracture systems. The availability of good topographic information aided the identification of topographic features which appear to mark geological boundaries (Sections 3 and 6).

Ordnance Survey Land-Form PROFILE data were used to create a shaded relief model of the topography at 1:50 000 scale. The solid geological boundaries were superimposed on an anaglyph plot of a similar shaded relief model. When viewed through spectacles with contrasting colour filters, anaglyph plots display the topography in three dimensions, enabling the correspondence between the geology and topography to be better appreciated and investigated.

Slope aspect analysis of the same DTM was carried out with the 3D Analyst extension to Arcview. The resulting plots were used for lineament analysis (Section 7.4.7).

3 The Chalk Group

3.1 INTRODUCTION

The Upper Cretaceous Chalk Group comprises predominantly soft to medium hard, white to off-white, very fine-grained and extremely pure, homogeneous, micro-porous limestones with subordinate beds of clay-rich chalk (marl), hardgrounds, calcarenite and flints.

The nomenclature for the Upper Cretaceous utilised in this district is shown in Table 1, where its relationship to the traditional scheme is also given. The current nomenclature is a development of the schemes devised by Mortimore (1983; 1986a) and by Bristow et al. (1995; 1997), and adopted by the Geological Society Stratigraphic Commission (Rawson et al., 2001). An alternative scheme of lithostratigraphic nomenclature proposed for the Chalk of the North Downs by Robinson (1986) is also shown in Table 1. Following discussion (Mortimore, 1987; Robinson, 1987), it is generally considered preferable to use a single scheme for the whole of southern England (Mortimore et al., 2001; Rawson et al., 2001). The relationships between the units used in this report and those used in Robinson's scheme are given by Rawson (1992), and also noted in the following, where relevant, to assist understanding of Robinson's measured sections in East Kent, which provided essential local information on the thickness of the Chalk formations. The correspondence of some marker bed names from different schemes of nomenclature is given in Table 2.

The Chalk is divided into two Subgroups, comprising a total of nine formations, of which seven are present in the North Downs of East Kent. Each formation is distinct in terms of overall lithological composition (nodular chalks, smooth white chalks, chalk marls, flinty chalks and so on) and rock mass character (density, porosity, strength, fracture style). These properties are in turn thought to influence the hydrogeological and engineering characteristics of the Chalk. For example, the fracture style is thought to influence the fracture/fissure volume, and (together with the presence or absence of chalk putty derived from the softer chalks) so also the hydraulic conductivity (Section 8).

The Chalk outcrop of East Kent is relatively complex, topographically. In the greater part of the area, the Chalk dips gently north-north-eastwards, being covered in the north by Palaeogene deposits. This main outcrop is bounded to the south-west by the North Downs escarpment, but is also divided in two by a weakly defined, subparallel, secondary escarpment (Figure 2). This bounds the north-eastern side of the Dour Valley at Dover, continuing north-westwards as far as the Barham Downs at Bridge. It is there offset to the south-west, continuing through the

Chartham Downs to the River Great Stour. This offset is apparently structurally controlled (Section 7.4.2).

Shaded relief maps derived from digital terrain models (Section 2.7) show a subtle but distinct change in topographic texture across this secondary escarpment. To the south-west, there are fewer dip-parallel valleys, which are more sharply incised and which have larger tributaries. There are generally well-defined, broad, planar interfluve areas, largely covered in superficial deposits. To the north-east, the topography is dominated by dip-parallel valleys and narrow intervening ridges, with few, fairly short tributary valleys. Incision is less, imparting a softer texture to the entire landscape.

In the north of the area, a westwards-plunging, east-west trending asymmetric fold brings the Chalk from beneath the Palaeogene cover to form the Isle of Thanet.

The total thickness of the Chalk in the North Downs of East Kent is generally between 237 m (at Margate) and more than 275 m, found in a 4 km-wide, approximately WNW-ESE belt at the southern limit of the Margate Chalk outcrop. Variations are probably due to local changes in thickness of the Holywell Nodular and New Pit Chalk formations, and within the Grey Chalk Subgroup (Holmes, 1981; Shephard-Thorn, 1988).

As described in Section 7, the structure of the Chalk of East Kent is relatively complex, compared with North Kent and with most other parts of the Chalk outcrop. This complexity arises in part from local folding but mainly from the extensive development of faults in several intersecting sets. Large-scale tectonic features in the Chalk are commonly accompanied by changes in the stratigraphic succession, at least locally (Mortimore and Pomerol, 1991). There is evidence for marked facies changes in the Lewes Chalk at Dover, for example, which are likely to be structurally controlled (C J Wood, oral communication, 2003). It cannot be assumed, therefore, that the Chalk succession is necessarily the same throughout the project area. In particular, the coastal exposures are not necessarily representative of the Chalk elsewhere in the North Downs in every respect. It is likely that much of the thickness variation discussed in the following sections has some underlying tectonic control.

3.2 GREY CHALK SUBGROUP

The Grey Chalk is divided into two formations, the West Melbury Marly Chalk and the Zig Zag Chalk (Table 1). It is essentially equivalent to the traditional Lower Chalk except that the topmost part of that unit, the Plenus Marls, is now included with the overlying Holywell Nodular Chalk. The Grey Chalk crops out along the lower part of the North Downs escarpment, and underlies the head of the Elham Valley.

In the Canterbury district, estimates of the thickness of the Lower Chalk (including the Plenus Marls) vary from about 65 m near the Great Stour to 80 m at Dover (Smart et al., 1966; Jenkyns et al., 1994). In the Faversham district, by contrast, it is reckoned to be a little less than 60 m (Holmes, 1981).

3.2.1 West Melbury Marly Chalk Formation

The West Melbury Marly Chalk generally underlies gently sloping ground at the base of the North Downs escarpment, but east of a fault zone at Etchinghill the outcrop is narrower and correspondingly steeper. It consists predominantly of rhythmically bedded, bluish grey marly (clay-rich) chalks with thin beds of grey to brown limestone. Each rhythm typically begins with a thick, dark blue-grey marl with much disseminated pyrite at the base, passing upwards through medium grey marly chalk to a thin, pale, hard limestone (Destombes and Shephard-Thorn, 1971; Harris et al., 1996). There is an overall upwards decrease in clay content, but calcium carbonate content is generally less than 75 per cent. It includes a locally abundant, moderately diverse marine invertebrate fossil fauna dominated by ammonites, bivalves, brachiopods, and in some

limestone beds, sponges. Certain beds, particularly the main limestone beds, have been given informal names (Mortimore et al., 2001), or are designated by alphanumeric codes (Gale, 1989). The West Melbury Chalk corresponds to the lower part of the East Wear Bay Chalk Formation of Robinson (1986).

A detailed stratigraphic scheme subdividing the sequence here known as the West Melbury Chalk was developed for the Channel Tunnel Project. The four 'TML units' vary significantly in thickness within the zone that was studied for that project. There is evidence for local structural control of thickness variations and facies changes: these variations are least in the uppermost of the 'TML units' (Harris et al., 1996).

The base is marked by the Glauconitic Marl Member (known in France as 'Tourtia'), comprising grey to green clay-rich chalk (marl) with variable proportions of glauconite and quartz sand. The lower boundary is placed at a strongly burrowed surface associated with a concentration of phosphatic nodules, overlying the clays of the Gault. The same boundary marks the base of the Lower Chalk in the traditional scheme. The Glauconitic Marl Member is very variable in thickness, reaching 7 m thick at Abbot's Cliff (Gale, 1989) but being no more than 2.2 m (and possibly as little as 0.4 m) in the Dover No. 1 (Aycliff) Borehole, only a few kilometres away (Mortimore et al., 2001, and BGS records for borehole TR23NE4). It is 7.3 m at Chilham (by the Great Stour) and 4.9 m at Ropersole, but only 0.9 to 1.2 m in a road cutting at the foot of Castle Hill, Folkestone, 1.5 m at Walmestone and Ottinge, 4.9 m at Copt Point, and 2.2 m at Shakespeare Colliery (Smart et al., 1966).

The limestone beds in the lower part of the formation are often spongiferous and occasionally contain glauconite grains. A limestone rich in the ammonite *Schloenbachia* which occurs in the middle of the succession was named the M3 limestone at Folkestone (Gale, 1989). The upper limestones of the West Melbury Chalk are generally poorly fossiliferous and lack sponges. The Tenuis Limestone occurs at the top of the formation, unless removed by erosion at the 'mid-Cenomanian break' (Wood et al., 1996; Mortimore et al., 2001).

The West Melbury Marly Chalk includes all the chalk of the Cenomanian *M. mantelli*, *M. dixoni* and *C. inerme* Zones and the basal part of the *T. costatus* Subzone (*A. rhotomagense* Zone). In terms of older biostratigraphic nomenclature, the West Melbury Chalk is approximately coextensive with the *S. varians* Zone.

The West Melbury Chalk is 33.7 m in thickness in the coastal sections at Abbot's Cliff, near Dover (Mortimore et al., 2001). Logs for twenty boreholes provide information from which the thickness of the unit can be estimated. These estimates range from 28.3 m to 48 m, with an average of 34.7 m. No consistent variation across the area is apparent, although estimates of the thickness of the Lower Chalk (Section 3.2) suggest a diminution to the west and north. Most values lie between 30 and 40 m, and the average of the 16 values in this range is 34.2 m. The typical thickness of the unit in East Kent is taken as 34 m.

The West Melbury Chalk is overlain conformably by the Zig Zag Chalk.

3.2.2 Zig Zag Chalk Formation

The Zig Zag Chalk crops out in the lower part of the North Downs escarpment, and underlies the head of the Elham Valley. It is typically composed of soft to medium-hard, pale grey, blocky chalk with some beds of limestone near the base. No flints are recorded in the Zig Zag Chalk in this area. With some exceptions, it tends to be more sparsely fossiliferous than the West Melbury Chalk, the most usual forms being ammonites, brachiopods, bivalves and thin-tested echinoids.

The base of the formation is taken as the base of the 'Cast Bed', a distinctive pale brown silty chalk containing abundant small brachiopods (Bristow et al., 1995; Bristow et al., 1997; Mortimore et al., 2001). The Cast Bed corresponds to Bed 4 of Jukes-Browne (1880; 1903). In inland areas, it typically coincides with a marked negative topographic feature.

The lower part of the formation has a higher clay content than the rest, and contains some thin limestone beds. It corresponds to the upper part of the East Wear Bay Chalk Formation of Robinson (1986). The upper part of the Zig Zag Chalk tends to be of pale grey to white, firm chalk with common bivalves such as *Inoceramus atlanticus* and *I. pictus* and the echinoid *Holaster subglobosus*. It is equivalent to Bed 7 and Bed 8 of Jukes-Browne (1880; 1903) which together comprise the Abbot's Cliff Chalk Formation of Robinson (1986). The top of this formation coincides with the top of the Zig Zag Chalk.

The base of the Zig Zag Chalk falls in the *Turrilites costatus* Subzone and the top is at the top of the *Calycocheras guerangeri* Zone. In terms of older biostratigraphic nomenclature, the Zig Zag Chalk is approximately coextensive with the *H. subglobosus* Zone.

The Zig Zag Chalk is 42 m in thickness in the coastal sections at Dover (Gale et al., 1999; Mortimore et al., 2001). Logs for twenty-two boreholes provide information from which the thickness of the unit can be estimated. These estimates range from 29 m to 47.4 m, with an average of 40.2 m. No consistent variation across the area is apparent, although estimates of the thickness of the Lower Chalk (Section 3.2) suggest a diminution to the west and north. Most values lie between 35 and 46 m, and the average of the 18 values in this range is 42 m. The typical thickness of the unit in East Kent is taken as 42 m.

The Zig Zag Chalk is overlain with slight disconformity by the Holywell Nodular Chalk.

3.3 WHITE CHALK SUBGROUP

The White Chalk Subgroup is divided into seven formations, five of which are known to occur in this area; namely the Holywell Nodular Chalk, the New Pit Chalk, the Lewes Nodular Chalk, the Seaford Chalk and the Newhaven Chalk (which is here represented by the Margate Chalk Member) (Table 1). The subgroup is essentially equivalent to the combined traditional Middle Chalk and Upper Chalk, except that the base of the Middle Chalk was placed at the top of the Plenus Marls, and the base of the White Chalk (that is, the base of the Holywell Nodular Chalk Formation) is defined as the base of the Plenus Marls (Table 1). The youngest known chalk in the area is in the Margate Chalk Member, a locally-developed facies of the Newhaven Chalk Formation, which occurs in this position elsewhere in southern England.

In the Faversham district, the Middle Chalk is about 60 m thick, and the Upper Chalk varies from 90 m upwards to a maximum of 115 m (Holmes, 1981).

In the Canterbury and Folkestone district, thickness estimates for the Middle Chalk vary between 61 m and 79.3 m, being typically about 70 m. The Upper Chalk attains 86.3 m in thickness at Boughton-under-Blean (TR05NE) (Smart et al., 1966).

In the Ramsgate and Dover district, the Middle Chalk is reckoned to be about 72 m thick, and the Upper Chalk up to about 128 m (Shephard-Thorn, 1988).

The Dover Chalk Formation of Robinson (1986) extends from the base of the Melbourn Rock to the Caburn Marl (the Crab Bay Marl of Robinson, 1986) and is 66.9 m thick at Dover. This unit is equivalent to the Middle Chalk minus the interval from Caburn Marl to the base of the Basal Complex (Section 3.3.3), so representing most of the Holywell Chalk and the New Pit Chalk combined. Taken together, the thickness of the Dover Chalk and of the overlying interval up to the base of the Basal Complex (estimated at between 3.6 and 4.5 m at the coast) is consistent with estimates for the Middle Chalk of about 70 m. Robinson (1986) estimates the thickness of the overlying Ramsgate Chalk Formation as 119.3 m.

Thus about 150 to 200 m of the White Chalk is estimated to crop out in East Kent.

3.3.1 Holywell Nodular Chalk Formation

In the west of the area, the Holywell Nodular Chalk underlies relatively gently sloping ground in the middle part of the North Downs escarpment, usually above a positive topographic feature marking the Melbourn Rock. In the greater part of the area, however, the Lewes Chalk crops out some way north of the escarpment, which is there capped by the Holywell Chalk. Inliers form the floor to the upper parts of some dry valleys. This change in the outcrop pattern is assumed to be structurally controlled, and related in some way to the fault zones controlling the offset in the secondary escarpment between Bridge and Petham.

The Holywell Chalk is relatively lithologically varied, comprising medium hard to very hard, nodular, white to creamy white chalk with beds and laminae of clay-rich chalk (marl), including flaser-laminated marls. Many beds in the upper part are gritty and contain conspicuous shell debris.

The basal member is the Plenus Marls, consisting of alternating beds of slightly greenish grey marls and marly limestones, resting with marked colour contrast on the eroded and burrowed surface of the Zig Zag Chalk. A standard succession of eight beds can be recognised at many localities (Jefferies, 1963). Estimates of thickness of the Plenus Marls from localities in North Kent vary considerably, suggesting that some sections might have been misinterpreted. Tectonic thinning or thickening of this relatively incompetent interval are also possible. Jefferies (1963, fig. 6) found some variation eastwards from the Medway, with about 1 m near the Great Stour. His isopachyte map shows all occurrences in Kent to be less than 2.5 m, although he recognises local variation in detail. The Plenus Marls are 2.4 m at Abbot's Cliff and about 2 m thick at Shakespeare Cliff, south of Dover (Mortimore et al., 2001). Outcrop and borehole data from elsewhere in the East Kent area show considerable apparent variation in the thickness of the Plenus Marls, between 1.3 m and 5.5 m. No consistent variation in the thickness of the unit is seen, and an average thickness of 2.5 m is taken to apply to the entire area.

The overlying Melbourn Rock Member (in the sense of Mortimore, 1986, pp. 103-104) comprises hard to very hard, yellowish-white nodular chalk with marl seams, generally lacking fossil material. It has been estimated at 1.8 to 4.6 m in thickness. The upper two-thirds of the Holywell Chalk is mostly conspicuously fossiliferous: most beds contain gritty shell debris, some have inoceramid bivalves preserved in three dimensions. In the absence of shell debris, the rather grainy texture of typical Holywell Chalk distinguishes it from the smooth chalks of the succeeding New Pit Chalk. The straight-shelled ammonite *Sciponoceras* is locally abundant in the lower part, and the rhynchonellid brachiopod *Orbirhynchia* is locally common. The unit also contains thin interbedded flaser marls but these are only readily apparent in exposed sections.

Note that some authors, such as Jukes-Browne and Hill (1903, p. 373) and Shephard-Thorn (1988), have taken a broader view of the Melbourn Rock at Dover, regarding it as some 10 m in thickness and extending into the fossiliferous overlying portions of the Holywell Chalk, following the concept of the 'Grit Bed' of Price (1877). The Melbourn Rock at Dover, in the narrower usage adopted in this report, was named the Ballard Head Member by Gale (1996). (Note that Mortimore (1986) placed the top of the Melbourn Rock at Meads Marl 1, whereas Gale (1996) defined the top of the Ballard Head Member slightly higher, at Meads Marl 6. This minor difference is unlikely to have any practical significance in East Kent).

Robinson (1986) treats the Plenus Marls as a separate formation. The rest of the Holywell Chalk lies entirely within his Shakespeare Cliff Member (lower part of the Dover Chalk Formation).

The Holywell Chalk spans the Cenomanian/Turonian boundary; the boundary occurring close to the top of the Melbourn Rock. Biostratigraphically, the *M. geslinianum* Zone encompasses the Plenus Marls Member and the lowest part of the Melbourn Rock. The rest of the Cenomanian portion of the Holywell Chalk lies within the *N. juddii* Zone. The Turonian part of the Holywell Chalk is in the *Mytiloides* spp. Zone. In terms of older biostratigraphic nomenclature, the Holywell Chalk excluding the Plenus Marls is approximately coextensive with the *I. labiatus*

Zone (although this zone actually extends up to the Malling Street Marl 1 - the Round Down Marl of Robinson, 1986) (Mortimore, 1986a).

At Dover, the Chalk from the base of the Melbourn Rock to the Malling Street Marls is condensed, with the loss of most of the marker beds seen in Sussex (Mortimore, 1987; Mortimore et al., 2001). A 7 m interval there seen between the Melbourn Rock and the beds with abundant shell debris in Sussex is absent in Kent (Mortimore, 1986b).

In the Dover district, the *labiatus* Zone is about 18 m thick (Shephard-Thorn, 1988). Measured sections at Dover show that there the Holywell Chalk is between about 12.5 and 14 m in thickness (Robinson, 1986; Gale, 1996). Logs for thirty-five boreholes provide information from which the thickness of the Holywell Chalk can be estimated. These estimates range from 8 m to 22 m, with an average of 17.3 m. No consistent variation across the area is apparent, although the thickness of the formation might be more variable (with more high and low values) in the south-east. Most values lie between 12 and 20 m, and the average of the 31 values in this range is 17.5 m. The typical thickness of the Holywell Chalk in East Kent is taken as 18 m.

The Holywell Chalk is overlain conformably by the New Pit Chalk.

3.3.2 New Pit Chalk Formation

In the west of the area, the New Pit Chalk Formation generally underlies steeply sloping ground within the upper part of the North Downs escarpment, above a persistent negative feature marking the top of the Holywell Chalk. Elsewhere, the Lewes Chalk crops out some way north of the escarpment, and the New Pit Chalk there forms a much broader outcrop, with relatively subdued relief. It underlies the Dour Valley and several of its tributaries.

The New Pit Chalk is typically composed of fairly pure massively bedded white chalks with pairs or groups of conspicuous marl seams. In the eastern part of the North Downs, however, the lowest 10 m or so of the New Pit Chalk is faintly nodular and contains chalk intraclasts (pebbles) (Robinson, 1986). It is generally medium hard, but softer than either the Holywell Chalk or the Lewes Chalk. In East Kent, the unit is flintless except at the top, where small flints are associated with the Glynde Marls: they are not a conspicuous part of the succession. The included fauna is much sparser than in Holywell Chalk, mostly comprising brachiopods (both terebratulids and rhynchonellids) rather than abundant inoceramid bivalves. Specimens of *Mytiloides hercynicus/subhercynicus* are present but they tend to be flattened and typically lack any preserved shell.

The base of the New Pit Chalk is taken at the base of the Gun Gardens Main Marl (the Lulworth Marl of Gale, 1996), this being marked by the upward disappearance of abundant shell debris and, generally, of nodular chalk. It also approximates to first appearance of flints in the North Downs, and in the South Downs. The lowest, nodular, parts of the New Pit Chalk were placed by Robinson (1986) with most of the Holywell Chalk in his Shakespeare Cliff Member. The rest of the New Pit Chalk corresponds to Robinson's (1986) Aycliff Member (mid-Dover Chalk Formation).

In the standard sections in Sussex the formation extends up to the base of Glynde Marl 1 (Mortimore, 1986). In the North Downs, the nodular chalks characteristic of the Lewes Chalk first appear a little higher in the succession, about 1 m above the topmost Glynde Marl (topmost Maxton Marl of Robinson, 1986) and in strength, some 10 m higher. This is discussed further in the following section.

Biostratigraphically the New Pit Chalk covers all but the highest part of the *Terebratulina lata* Zone. At least 16 m of *lata* Zone chalk can be assigned to the succeeding Lewes Chalk. The base of the New Pit Chalk lies in the topmost part of the *Mytiloides labiatus* Zone of the traditional scheme.

In the Dover district, the *lata* Zone is about 54 m in thickness (Shephard-Thorn, 1988). In the cliffs at Dover, the Holywell Chalk together with the New Pit Chalk (the interval from the base of the Plenus Marls to Glynde Marl 2) is 47 m (Mortimore and Pomerol, 1987) (implying the New Pit Chalk is about 29 m in thickness), although this decreases in nearby boreholes and westwards generally. According to sections illustrated by Robinson (1986), the New Pit Chalk is 33.9 m in thickness at Akers Steps (from the Gun Gardens Main Marl to Glynde Marl 2). In the present project, the top of the New Pit Chalk is placed about 17 m above Glynde Marl 2.

Logs for twenty-two boreholes provide information from which the thickness of the unit can be estimated. These estimates range from 26 m to 45 m, with an average of 36.2 m. No consistent variation across the area is apparent. Most values lie between 33 and 40 m, and the average of the 18 values in this range is 35.9 m. The typical thickness of the unit in East Kent is taken as 36 m.

The New Pit Chalk is overlain conformably by the Lewes Nodular Chalk.

3.3.3 Lewes Nodular Chalk Formation

In the west of the area, the Lewes Nodular Chalk forms the crest of the North Downs escarpment. Elsewhere it crops out some way north of the escarpment, underlying much of the Chalk dip slope, in places as far north-east as the foot of the secondary escarpment (Section 3.1).

The Lewes Chalk comprises interbedded hard to very hard nodular chalks and hardgrounds with soft to medium-hard grainy chalks and marls. The nodular chalks are typically lumpy and iron-stained, this iron-staining usually marking fossil sponges. Rock fragments in the soil (brash) are rough and flaggy. The first regular seams of flint appear near the base and flints are a conspicuous part of the succession. Most flints are nodular, but some tabular flints also occur. An abundant and diverse molluscan fossil fauna can be found in some beds, including ammonites, bivalves and gastropods. Echinoids and brachiopods occur throughout and are also important to biostratigraphy.

In exposed sections the Lewes Chalk can be divided informally into two units. The lower part is mainly medium to high-density chalks and conspicuously iron-stained hard nodular chalks, whilst the upper is mainly low to medium-density chalks with regular thin nodular beds. The boundary between the two units is marked by the Lewes Marl and the Lewes Flints, the latter being an extensive system of black cylindrical burrow-form flints. The upper part of the Lewes Nodular Chalk is further distinguished by the occurrence of the bivalve *Cremnoceramus* (Mortimore, 1986a). There are several levels of tabular flint within an interval of 4 or 5 m in the lower part of the Upper Lewes Chalk.

The Lewes Nodular Chalk includes the top of the *Terebratulina lata* Zone, and all of the *Plesiocorys* (*Sternotaxis*) *plana* (previously *Sternotaxis plana*, and prior to that *Holaster planus*) and *Micraster cortestudinarium* zones.

The Lewes Chalk is very approximately equivalent to the lowest part of the traditional Upper Chalk. In the Chilterns, the Berkshire Downs and areas to the west, the base of the Upper Chalk was placed at the base of the Chalk Rock. This is a characteristic succession of mineralised hardgrounds and associated very hard chalks, generally less than 5 m in thickness, representing a condensed succession. However, the Chalk Rock is absent in the more expanded successions of the North Downs (where it is represented by perhaps as much as 40 m of strata). Instead, the base of the Upper Chalk has there generally been defined as the base of the *plana* Zone, but this horizon may be difficult to recognise, and in practice it has been taken at the first appearance of the '*reussianum* fauna' or at the 'Basal Complex'.

The '*reussianum* fauna' is found only in certain beds in the nodular chalk of the basal *plana* Zone of southern England. It is named after the uncoiled ammonite *Hyphantoceras reussianum*. It largely comprises moulds of a variety of fossils and is unusual in that it includes aragonite-

shelled molluscs such as ammonites and gastropods which are not generally preserved in other chalk facies. Hexactinellid sponges are also abundant (Gallois, 1965).

The 'Basal Complex' of the North Downs constitutes a thin succession of closely spaced marl seams associated with large, nodular flints (Mortimore and Wood, 1986, and references therein). In ascending order these beds comprise the Bridgewick Flints, the Bridgewick Marls, and the Bopeep Flints (Mortimore et al., 2001). The Basal Complex coincides with the maximum development of flints (including some flints of unusually large size) in the high Turonian throughout the English Chalk, at or about the base of the *plana* Zone (Mortimore and Wood, 1986, p. 10-11). In all areas this is overlain by beds with a maximum development of the *reussianum* fauna, and is underlain by a succession of chalks, some nodular, including several well-developed and laterally continuous discrete marls seams.

The Basal Complex can be traced throughout the North Downs and its base was used to define the base of the *plana* Zone and thus the base of the Upper Chalk in some previous accounts, notably those of the Geological Survey. It gives rise to a mappable topographic feature (Smart et al., 1966, p. 123; Mortimore and Wood, 1986, p. 11; Holmes, 1987; Shephard-Thorn, 1988).

The base of the Lewes Chalk, however, corresponds to the appearance of indurated or nodular chalks above the New Pit Chalk Formation, which occurs significantly below the Basal Complex. It is taken at the uppermost Glynde Marl (4) in Sussex (Mortimore and Pomerol, 1996), and elsewhere in southern England in the interval between the Glynde Marls and the Southerham Marls (Bristow et al., 1997).

In Robinson's stratigraphic scheme, the base of the Akers Steps Member (top of the Dover Formation) is stated (Robinson, 1986, p. 153) to coincide with the change from underlying flintless soft white chalk with marl seams and rare beds of weakly nodular chalk, to mainly nodular chalk with laterally extensive flint beds. This level has been taken to correspond to the base of the Lewes Chalk (Mortimore et al., 2001): it occurs about 1 m above the topmost of the Maxton Marls of Robinson (1986) (equivalent to the Glynde Marls of Sussex; Mortimore, 1986), some 5.8 m above Maxton/Glynde Marl 2 at Akers Steps (Table 3). At Akers Steps, the base of the Akers Steps Member is about 1.5 m below the lowest laterally persistent flint, the Lydden Spout Flint (Robinson, 1986).

Mortimore and Pomerol (1987) point out that the interval between the Glynde Marls and the Southerham Marls (Langdon Bay Marls) at Akers Steps is considerably expanded, a feature that they say is found throughout much of Kent. This obscures the incoming of nodular chalks at this level. Indeed, Robinson's (1986) Figure 9 indicates that nodular chalk appears in strength only partway up the Akers Steps Member, some 8 m above the Lydden Spout Flint (and so about 10 m above the base of the Akers Steps Member), and 3.5 m below Southerham Marl 1. This is consistent with the description by Shephard-Thorn (1988, p. 19 and p. 21) who states that several bands of weakly nodular chalk occur in the 5 m of strata below the Southerham Marls (Rowe's 'four-foot band'), and to within some 7 m above the Lydden Spout Flint. This level is some 13 m below the Caburn Marl (Crab Bay Marl), and so about 17 m below the base of the Basal Complex. He states that no nodular chalks are noted lower in the uniform *lata* zone chalk, until the base of the zone is reached.

Indeed, there is evidence for major thinning of the Akers Steps Member near Godmersham [059 506] (compared with the 22.9 m measured at the coast) although the full thickness of the unit cannot be measured (Robinson, 1986). In North Kent, the Akers Steps Member is recorded as consistently some 10 m thinner than that at Akers Steps itself (Farrant and Aldiss, 2002).

Interpretation of geophysical borehole logs (Section 6.3) indicates that the main change in lithology, characteristic of the boundary between the New Pit Chalk and the Lewes Chalk, occurs at about the same level as described by Shephard-Thorn (1988). Four borehole records in East Kent show a depth for both the base of the Upper Chalk (from lithological logs) and the

base of the Lewes Chalk (from geophysical logs). The values of the difference range from 15.1 to 16.6 m.

It thus seems that a level some 16 m below the base of the Upper Chalk, as mapped and as noted in borehole records, would give a reasonably consistent value for the depth to base of Lewes Chalk. Although this would still be some 10 m higher in the succession than if the base of the Lewes Chalk were taken at the base of the Akers Steps Member, at least near the coast, it would approximately correspond to the change in physical properties seen in the geophysical logs, and by inference the mappable horizon in unexposed ground.

In the terminology of Robinson (1986), the Akers Steps Member is overlain by the St Margarets Member (lower part of Ramsgate Chalk Formation) at the Crab Bay Marl. This marl (which is equivalent to the Caburn Marl of Sussex) occurs some 3 to 5 m below the Basal Complex. The rest of the Lewes Chalk corresponds to the *plana* Zone and the *cortestudinarium* Zone. The top of the Lewes Chalk coincides with the top of the St Margarets Member.

In the standard Sussex succession the Lewes Nodular Chalk extends up to the base of Shoreham Marl 2 (Mortimore, 1986). A distinctive unit of chalk with the trace fossil *Zoophycos*, the Beachy Head *Zoophycos* Beds, occurs near the top of the Lewes Chalk. This can be traced northwards from Dover through the London Basin (where it is seen in borehole cores) (Mortimore et al., 2001). This unit is usually overlain by the two Shoreham Marls and the intervening bed of Shoreham Tubular Flints; conspicuous markers in both borehole core and exposures (Mortimore et al., 2001). The tubular flints between the Shoreham Marls are present in the East Cliff section at Dover (Mortimore, 1986a).

In the Dover district, the *plana* Zone chalk is about 15 m thick and the *cortestudinarium* Zone chalk is about 20 m thick (Shephard-Thorn, 1988). In the Canterbury district, the *plana* Zone is between 13 and 15.2 m, whilst the *cortestudinarium* Zone is around 17 to 23 m thick (Smart et al., 1966). As discussed above, there probably about 16 m of the Lewes Chalk falls within the *lata* Zone. These estimates imply that the Lewes Chalk is about 50 m in thickness, on average (*lata*: 16 + *plana*: 14 + *cortestudinarium*: 20).

Published accounts suggest that the Lewes Chalk is about 50 to 53 m in thickness in the coastal sections at Dover (Mortimore and Wood, 1986; Robinson, 1986; Gale, 1996).

Logs for eight boreholes provide information from which the thickness of the Lewes Chalk can be estimated. These estimates range from 34 m to 62 m, with an average of 57.2 m. Of these, the single record of less than 58 m is based on an interpretation of fossil occurrences in the Guildford colliery shaft records. No consistent variation across the area is apparent. Most values lie between 58 and 61 m, and the average of the 6 values in this range is about 60 m. The typical thickness of the unit in East Kent is suggested to be 60 m, although this estimate is based on a small dataset and might be up to 10 m too great.

The Lewes Chalk is overlain conformably by the Seaford Chalk.

3.3.4 Seaford Chalk Formation

To the south-west of the secondary escarpment, the Seaford Chalk occurs as outliers and broad cappings on the long dip slopes formed by the Lewes Chalk. To the north-east, together with the Margate Chalk, it forms the entire dip slope. In the Isle of Thanet, it occurs at the coast and in several inliers including one within the south-dipping limb of the Thanet Anticline.

The Seaford Chalk is composed mainly of soft, blocky white chalk with common seams of small to very large flint nodules. There are rare occurrences of faintly nodular chalk (particularly in the lower third or so), thin marl seams and tabular flint beds. The flints are typically black to bluish-black, and mottled grey with a thin white cortex, and they commonly contain bivalve shell fragments, and in some cases echinoids.

In addition to the shelly flints, many other beds within the Seaford Chalk contain macrofossils, of which inoceramid bivalves and echinoids are the most significant biostratigraphically. For example, the lower part of the Seaford Chalk contains abundant fragments of the bivalves *Volviceramus* and *Platyceramus*, whilst the upper part contains *Cladoceramus* and *Platyceramus* (Mortimore, 1986). The echinoid *Conulus* occurs in the top half of the Seaford Chalk, and commonly in the top 15 m or so. An acme bed occurs just above Barrois' Sponge Bed, and so provides an excellent marker near the base of the Margate Chalk. These fossils can be found in rock fragments in the soil (brash), as well as in exposed bedrock.

There are several key marker horizons present in the upper part of the Seaford Chalk. Barrois' Sponge Bed (BSB) is a conspicuous 200-300 mm-thick yellowish iron-stained nodular sponge bed which occurs at the very top of the Seaford Chalk, and defines the boundary with the overlying Margate Chalk on the Isle of Thanet (Mortimore et al., 2001). According to Holmes (1981), Barrois' Sponge Bed may become indefinite in the Faversham district. However, its horizon can be identified as far west as Selling [0353 5698], some 10 km west of Canterbury (Smart et al., 1966, p. 152).

'Whitaker's Three-Inch' Flint Band is a prominent, nearly continuous single tabular flint seam 6 m below the BSB. Bedwell's Columnar Flint, is a similarly prominent bed, comprising a conspicuous line of double flints with occasional vertical columns of flint. On the Kent coast this occurs about 13 m lower than Whitaker's Three-Inch, this interval diminishing to about 8.8 m to the west in the Canterbury area.

Biostratigraphically, the Seaford Chalk is approximately co-extensive with the *Micraster coranguinum* Zone (Table 1), with only the topmost 3 m of the zone being in the Margate Chalk (Section 3.3.5). It crosses the Coniacian/Santonian boundary, marked by the incoming of *Cladoceramus* (Mortimore, 1986).

In the Dover district, the *coranguinum* Zone chalk is about 65 m thick (Shephard-Thorn, 1988), and about 60 m thick in the Faversham district (Holmes, 1981). In the Canterbury district, the *coranguinum* Zone probably reduces to about 61 m in the area of the Chartham Downs (Smart et al., 1966).

Measured sections show that the Seaford Chalk is about 59 m in thickness at the coast (Robinson, 1986). Logs for only six boreholes provide information from which the thickness of the Seaford Chalk can be estimated. These range from 45.7 m to 61 m, with an average of about 52 m. The typical thickness of the unit in East Kent is taken as 52 m.

The Seaford Chalk is overlain conformably by the Margate Chalk.

3.3.5 Margate Chalk Member (Newhaven Chalk Formation)

The Margate Chalk represents a facies of the Newhaven Chalk Formation found only in north-east Kent (although it possibly extends to the north, offshore and perhaps in East Anglia). It forms the long dip slopes north of the secondary escarpment, although it is much dissected to expose the underlying Seaford Chalk. It also underlies most of the Isle of Thanet. The Member occurs only very locally west of Canterbury. It is composed mainly of smooth white chalk without marl seams and with a few, generally inconspicuous, flints.

Many beds within the Margate Chalk contain macrofossils, of which crinoids and echinoids are most significant biostratigraphically. The echinoid *Conulus albogalerus* has an acme horizon just above Barrois' Sponge Bed. These fossils can be found in rock fragments in the soil (brash), as well as in exposed bedrock.

As noted in Section 3.3.4, Barrois' Sponge Bed forms the top of the Seaford Chalk (Mortimore et al., 2001). On the Isle of Thanet, the base of the *Uintacrinus socialis* Zone occurs some 3 m above Barrois' Sponge Bed (Mortimore et al., 2001). Thus, the Margate Chalk occupies the topmost *Micraster coranguinum* Zone, and extends upwards through the three 'crinoid zones'

(the Zones of *Uintacrinus socialis*, *Marsupites testudinarius* and *Uintacrinus anglicus*), locally reaching the *Offaster pilula* Zone (Table 1). Note that in older accounts the three crinoid zones are treated together as a single ‘*Marsupites* Zone’.

Erosion of the Chalk following regional folding and prior to Palaeogene deposition has given rise to a south-westwards overstep. Up to 6 m of chalk in the *Offaster pilula* Zone is preserved inland between Broadstairs and Margate, but the Palaeogene rests on chalk of the *testudinarius* Zone at Pegwell Bay, chalk of the *socialis* Zone at the western end of the Isle of Thanet, and on *coranguinum* Zone chalk on part of its southern margin (Shephard-Thorn, 1988). Geological modelling suggests that the Margate Chalk has been removed by erosion, prior to deposition of the Thanet Sand Formation, from a broad area south of the Isle of Thanet. Holmes (1981, p. 25) considers that no *socialis* chalk is present beneath Palaeogene cover to the west of the small Chalk inlier north of Chislet.

The Margate Chalk outcrop is largely cut out by the Palaeogene west of Canterbury, presumably reflecting a measure of fault control. A ‘few feet’ of *socialis* Zone chalk was recorded near Boughton-under-Blean [051 583], there being about 9 m of Chalk above Whittaker’s Three-Inch Flint (Smart et al., 1966). This implies that 3 or 4 m of the Margate Chalk is preserved in that locality, its westernmost known outcrop.

Measured sections suggest that the preserved thickness of the Margate Chalk varies up to about 24 m in the coastal sections around the Isle of Thanet, and perhaps attains as much as 28 m inland between Broadstairs and Margate (Robinson, 1986; Shephard-Thorn, 1988; Mortimore, 1997).

The Margate Chalk is overlain unconformably by the Thanet Sand Formation.

4 The Palaeogene

The Palaeogene (Tertiary) deposits were not mapped during this study. Further details are available in the memoirs for the region. The stratigraphic nomenclature used in this report follows Ellison et al. (1994). The formations are discussed further by Aldiss and Farrant (2002).

4.1 THANET SAND FORMATION

The Thanet Sand Formation, previously known as the Thanet Beds, or Thanet Sands, consists of bioturbated glauconitic silts, clays and fine- to very fine-grained sands deposited in an inner marine shelf to coastal setting, above fair weather wave base.

A thin pebble bed (the ‘Bullhead Bed’) is present at the base. It consists of unworn, green-coated flints in a matrix of bright green, glauconite-rich clayey sand and is typically 10 to 20 cm thick. The clayey matrix of this unit may render it less permeable than the overlying sands and silts. The remainder of the succession has been subdivided according to predominant lithology, although the subdivisions have not been mapped, as described by Smart et al. (1966), Ward (1977) and Shephard-Thorn (1988).

In East Kent, the Thanet Sand ranges in thickness from about 30 m in the Richborough Syncline, increasing to as much as 37 m in the Canterbury district. It is overlain unconformably by the Upnor Formation: in places significant parts of the Thanet Formation were removed by erosion prior to deposition of the Lambeth Group (Curry, 1981).

4.2 UPNOR FORMATION (LAMBETH GROUP)

The Upnor Formation, previously known as the Woolwich Bottom Bed or similar, is typically composed of variably glauconitic, fine- to medium-grained sand, with beds and stringers of well-

rounded, black flint pebbles. When fresh, the sands are dark grey brown to dark green, depending on the proportion of glauconite (which can exceed 25 per cent). They weather pale brown to yellow brown, but the glauconite remains dark green. The sands are extensively burrowed but locally cross-bedding remains.

The base of the formation rests unconformably on the Thanet Formation. The boundary is generally sharply defined, being marked by an upward change to medium-grained sand, with burrows of glauconitic sand extending as much as 0.5 m downwards into the Thanet Formation. A basal flint pebble bed is present in the west of the area, but is absent to the east. Bioturbation has there resulted in a gradational junction with the underlying Thanet Sand, and the grain size contrast can be difficult to pick out.

The formation was deposited in a marine shelf to coastal environments, predominantly with high energy, and partly influenced by tidal currents (Ellison et al., 1994).

In East Kent, the formation is up to about 9 m in thickness. The topmost part, and the overlying Woolwich Formation, was removed by erosion prior to the deposition of the Harwich Formation.

The upper boundary is generally well-defined, being overlain unconformably by the Harwich Formation.

4.3 HARWICH FORMATION (THAMES GROUP)

The Harwich Formation was previously known generally as the London Clay Basement Bed, in North Kent as the Oldhaven Beds and in the London area as the Blackheath Beds. It appears to consist mainly of fine-grained sands. The base is sharply defined, formed by a planar or slightly undulose discontinuity with a basal lag of rounded flint pebbles and fine- to coarse-grained quartz sand in a finer glauconitic matrix.

The formation was deposited on a shallow marine shelf, with slow, interrupted sedimentation, and periodic storm-generated activity.

The thickness is laterally variable, ranging up to about 6 m in East Kent. The Harwich Formation is overlain disconformably by the London Clay.

4.4 LONDON CLAY FORMATION (THAMES GROUP)

The London Clay Formation comprises silts and clays, with discrete beds of septarian nodules, and, where weathered, in places containing selenite crystals.

The base is sharply defined at a planar or slightly undulose discontinuity with a basal lag of rounded flint pebbles and fine- to coarse-grained quartz sand in a finer glauconitic matrix. Burrows commonly extend down into underlying beds.

The formation was deposited on a shallow marine shelf, with slow, interrupted sedimentation, and periodic storm-generated activity.

The London Clay is the youngest Palaeogene formation found in East Kent. Its thickness ranges up to about 145 m in the Faversham district (Holmes, 1981) although to the east of the Great Stour only thin outliers remain.

5 Superficial Deposits

The Quaternary superficial (drift) deposits were not mapped or revised during this study. Across the Chalk outcrop, the most widespread superficial deposits are River Terrace Deposits, Alluvium, Brickearth, Head and Clay-with-flints. Further details are given in the memoirs for the

respective portions of the project area (Smart et al., 1966; Holmes, 1981; Shephard-Thorn, 1988).

6 Geological Modelling

6.1 THE MODELLING PROCESS

The three dimensional (3D) geological model comprises a series of eight layers, representing the seven Chalk formations and the overlying Palaeogene, which was not subdivided. Contoured images of the eight basal surfaces appear in an Arcview project displaying digital datasets arising from the East Kent project.

Data on the position of the surfaces bounding each layer was compiled from the sources described in Section 2. The ground surface was modelled using Ordnance Survey (OS) 1:10 000 LandformProfile dataset. This DTM provided elevation data at a 5 m vertical resolution.

The intersection of each geological surface with the ground surface is shown by the geological map. Linework for the base of each of the Chalk formations and of the base of the Palaeogene was newly compiled manually, as described in Section 6.2, and digitised.

The relatively convoluted outcrop patterns and generally simple structure suggested that manual modelling of the formation boundaries near surface would be successful. Moreover, this would enable a mapping geologist to make a generalised interpretation of the structure, taking account where imperfections in the linework are most likely to occur (for example, where a boundary has been traced through steeply sloping woodland), prior to computer modelling.

Therefore, where the mapped outcrop patterns allowed, arrays of structure contours were constructed manually for the near-surface occurrence of the base of the West Melbury Chalk, the Holywell Chalk, the Lewes Chalk, the Seaford Chalk, the Margate Chalk and the Palaeogene. Structure contours were also constructed for the base of the *testudinarius* Zone within the Margate Chalk on the Isle of Thanet. (Outcrop patterns for the base of the Zig Zag Chalk and for the base of the New Pit Chalk were constructed according to the position of the neighbouring formation boundaries (Section 6.2) and so structure contours for these new surfaces will follow the same patterns as those from which they were derived, at least close to outcrop). This process, carried out on 1:10 000 scale basemaps with contours at 5 m vertical interval, enabled the approximate delineation of several previously unrecognised faults (Section 7.4). The hand-drawn structure contours were also digitised and used to guide the construction of the near-surface portions of the 3D model.

Lithological or lithostratigraphical records for boreholes within the area were scrutinised for information on the formation boundaries, and the depth of each boundary within the borehole recorded. Inaccuracies can occur in any aspect of the borehole data: in the original record, in its subsequent interpretation, in the recorded location of the borehole, or in the ground elevation at the borehole site. So far as possible, these elements were checked for each individual borehole.

The National Grid coordinates for boreholes with useful information were taken from the BGS Single Onshore Borehole Index (SOBI). In some cases this was corrected by reference to borehole records, particularly those modern records made available by the water companies.

The ground surface level (relative to Ordnance Datum) for each borehole was taken from the borehole record, where recorded. Recorded levels were checked against OS Land-Form PROFILE elevation data for plausibility. Where levels were not recorded, or were obviously incorrect for a known borehole location, the level was interpolated from the Land-Form PROFILE elevation data.

Geophysical boreholes were scrutinised in a similar way. The geophysical records for each borehole were first interpreted individually, but then each interpretation was compared with that of its nearest neighbours, as a further check on the consistency of the interpretation.

Interpreted borehole data (and seismic data) were then used to generate a structure contour plot for each of the formation boundaries, enabling the borehole records to be considered relative to each other, in their local context. This second stage of checking revealed a number of obvious errors, only some of which could be corrected. Borehole records which gave rise to obvious anomalies in the modelled surfaces and which seemed to be in some way unreliable (e.g. over-simplified drillers' logs) were discarded. This is a subjective process but it tends to lead to a model based on a relatively self-consistent dataset. However, possibly anomalous but apparently correct records were left in the dataset, on the grounds that the apparent anomalies could be, in some way, 'real'. Note that borehole records which are somehow incorrect but which are nevertheless consistent with the model will generally remain unsuspected.

The location of borehole data used for the geological model appear as a theme in an Arcview project displaying digital datasets arising from the East Kent project. A data table underlying this theme records index information for each borehole and (except where the borehole record is held in confidence by BGS) the stratigraphic interpretation.

The seismic reflection surveys, forming an open grid (Figure 3), and relevant borehole information were loaded to a Geographix workstation and the interpretation made. Seismic 'picks' were carried on each seismic reflection line for the base Upper Chalk, the base of the Middle Chalk and the base of the Lower Chalk. These interpretations were calibrated by reference to the Venson borehole (TR35SW24). The seismic picks represent a reasonable approximation to the bases of the Lewes, Holywell and West Melbury chalk formations. (The distribution of the seismic survey lines also appears in an Arcview project displaying digital datasets arising from the East Kent project).

The completed seismic interpretation in two-way-travel-time (twtt) was exported as xyz values for each horizon, and depth-converted using interval velocities from surface to the seismic pick. Velocities for the Chalk intervals were calculated from the sonic log in the Venson borehole. The depth-converted values for the three horizons were then supplied as xyz digital data, along with fault intersections for inclusion in the subsurface modelling in EarthVision. Final minor adjustments to the depth-conversion were performed by differential warping within EarthVision, to ensure consistency between the data derived from the seismic reflection data and from the borehole records.

The quality of geological models constructed using EarthVision is highly dependent on the data that is used to construct them. In this study area, the quality and quantity of the data available to define the position of each geological surface in the model is spatially variable. The available data is, however, generally of reasonable or high quality at outcrop and in subsurface records. The relative reliability of each surface is discussed in Section 6.2.

6.2 MAPPING THE NEW CHALK LITHOSTRATIGRAPHY

6.2.1 General procedure

New or revised linework to depict the new Chalk formations (Sections 1 & 3) was compiled using data from many of the sources outlined in Section 2.

The 1:10 560 scale standards and selected field slips were enlarged to 1:10 000 scale on a large-format photocopier. The existing lines for the base of the Lower Chalk, Middle Chalk, Upper Chalk and base of the Thanet Formation were traced from these enlarged maps to 1:10 000 scale OS Landplan maps on a light table, matching the positions of local topographic features to make small adjustments of scale or registration, where required.

Relevant information from biostratigraphic records, annotations on field slips and the available literature was also plotted onto the 1:10 000 scale base-maps. New linework for each Chalk formation was then constructed, as described in the following sections.

Field mapping of the Chalk formations depends on the interpretation of small to medium-scale topographic features which can normally be located much more accurately on the ground than on the 1:10 000 scale topographic maps, even if they can be identified on the maps at all. A brief field reconnaissance was carried out as part of the present study, but this was sufficient only to assess the likely topographic expression of the Chalk formation boundaries, and the probably accuracy with which they had been surveyed. The newly compiled linework was not checked systematically. For these reasons, the new linework should be regarded as an approximation which would be significantly improved by detailed field mapping.

The BGS Memoirs for the Canterbury district (Smart et al., 1966) and for the Ramsgate and Dover district (Shephard-Thorn, 1988) both include small-scale diagrams showing biostratigraphic subdivisions of the Upper Chalk. For the present compilation, these diagrams were enlarged to 1:50 000 scale and the significant linework traced onto a 1:50 000 scale topographic map. It was then transferred by eye to the 1:10 000 scale basemaps, guided by those features shown on the maps at both scales.

These diagrams were originally compiled using biostratigraphic information from bedrock exposures. The position of the biozonal boundaries was interpolated between these exposures taking due account of the topography and geological structure, but no use was made of 'feature-mapping' to trace the boundaries across unexposed ground, as is done in lithostratigraphic mapping (B C Worssam, E R Shephard-Thorn, pers. comm., 2003). Furthermore, much of this desk compilation, particularly in the Canterbury district, was done on 1:10 560 scale maps with contours at only 100 foot vertical interval. This suggests that the interpretation was relatively generalised, with the strong possibility that some local structures remained unrecognised.

Indeed, as is discussed further in following sections, compilation of structure contours for the current project has suggested that faulting is more common than previously supposed. In some places, the mapped outcrop pattern suggests that faulting is probably present, but provides insufficient evidence to plot fault lines with any confidence. It is probable that lithostratigraphic mapping would confer sufficient additional precision to the outcrop patterns to enable some local structure to be resolved.

6.2.2 Base of West Melbury Marly Chalk Formation

The Glauconitic Marl is readily recognisable in the field, as is the contrast between the Gault and the Chalk. In East Kent, the base of the Chalk as mapped coincides with a weakly defined break of slope, commonly with a positive break of slope a short distance above. In some places, as south-west of Stowting [11 41], the positive break of slope is more conspicuous than the negative one below. In the west of the area, at least, the ground then tends to rise in a series of broad 'steps', presumably corresponding to the better-formed limestones in the 'Chalk Marl'. This 'stepped' appearance, which is best seen on topographic ridges, contrasts with the more uniform southwards slopes in comparable situations on the Gault outcrop.

The existing mapped boundary for the base of the Lower Chalk is thus considered to be reasonably reliable, although it is commonly covered by superficial deposits. The accuracy with which it was mapped would also be limited by the less detailed contours shown on the old 1:10 560 scale maps. Also, in some places, this boundary appears to have been placed at a spring-line without any corroborative evidence, although springs can occur above the base of the West Melbury Chalk. In adopting the mapped base of the Lower Chalk as the base of the West Melbury Chalk, adjustments have been made locally to make it consistent with the modern five metre contours, while taking account of where the Glauconitic Marl has been recorded on field slips.

In boreholes, this boundary can be accurately located in lithological logs if the Glauconitic Marl has been correctly recognised, and if its base has not been obscured by bioturbation. In the absence of a clearly defined Glauconitic Marl, the lower part of the West Melbury Chalk can appear misleadingly similar to the Gault.

In the East Kent study area, definition of the base of the Chalk solely on borehole geophysical evidence is problematical (Section 6.3.2).

The boundary is identifiable on seismic sections.

6.2.3 Base of Zig Zag Chalk Formation

The base of the Zig Zag Chalk has not been previously surveyed in East Kent. Neither the Cast Bed (at the base of the formation) nor the Tenuis Limestone which immediately underlies it (in complete successions) were recorded during the original large-scale survey. Some of the geophysical logs penetrate this boundary, although it can be identified on such logs with less confidence than can the base of the West Melbury Chalk or of the Holywell Chalk (Section 6.3.4). It is recorded in only a few of the lithological borehole logs, chiefly those made for the Channel Tunnel projects where it corresponds to the boundary between the 'Craie Bleu' and the 'Craie Grise'.

The new mapped boundary was constructed by reference to thickness determinations from these borehole logs, and from published estimates for the thickness of the approximately equivalent biozones (Sections 3.2 & 3.3). In East Kent, in 15 paired determinations of WMck and Zck, WMck formed between about 38% and 55% of the total. The average is 45.5%, the same as in North Kent. The base of the Zig Zag Chalk was therefore placed at a level equivalent to about half the vertical distance between the new mapped base of the Holywell Chalk (Section 6.3.4) and the new mapped base of the West Melbury Chalk (Section 6.3.2), constrained where possible by the limited biostratigraphical data for individual localities.

The base as mapped generally lies at or a short distance above a strong negative break of slope, above which the ground rises uniformly and much more steeply than below, as for example east of Brook [07 44, 08 44]. These characters are consistent with landforms associated with the two formations of the Grey Chalk Subgroup in other parts of southern England. However, this topographic feature is lost near Wye [06 47], approaching the River Great Stour.

The absence of any positive observations of this boundary, particularly in the subsurface, make it the least well-constrained of any in the 3D model.

6.2.4 Base of Holywell Nodular Chalk Formation

This is close to the base of the traditional Middle Chalk, differing only in that it is taken slightly lower, at the base of the Plenus Marls (Table 1). Both the Plenus Marls and the Melbourn Rock are readily identifiable in the field where exposed, and the Melbourn Rock gives rise to a characteristic topographic feature. The previously surveyed line for the base of the Middle Chalk is therefore probably very reliable, although the accuracy with which it was mapped would be limited by the less detailed contours shown on the old 1:10 560 scale maps. Also, the accuracy of mapping would be less where the base of the Middle Chalk crops out within steep slopes, particularly where these are wooded. This boundary is readily identified on geophysical and lithological logs, and from seismic records.

A standard value of 2.5 m was adopted for the thickness of the Plenus Marls (Section 3.3.1), and for boreholes in which the base of the Middle Chalk is recorded, but not the base of the Holywell Chalk, this value was added to the depth of the former to derive a depth for the latter, for modelling purposes.

As the Plenus Marls is relatively thin, as its variation is poorly known, and as the unit generally occurs in relatively steep ground and so has a very narrow outcrop, the existing line for the base

of the Middle Chalk was taken as the base of the Holywell Chalk, with some minor local adjustments to improve consistency with the modern five metre contour set.

Structure contours were constructed manually for the outcropping portion of the base of the Middle Chalk. To be consistent with the treatment of the borehole data, 2.5 m was subtracted from the height value of each to give a set of contours for the base of the Holywell Chalk, for modelling purposes.

In the field, the base as mapped lies close to a positive break of slope, in many places rather poorly defined. This feature probably lies slightly above the base of the Melbourn Rock, so the base of the Middle Chalk may have been mapped consistently high. Locally there is a weak negative feature a few metres below, presumed to mark the Plenus Marls. In ploughed fields the positive feature is associated with plentiful fragments of hard nodular chalk, as near Wye [06 46], some of it shelly.

This boundary is quite well constrained in the 3D model, both by surface mapping and from borehole and seismic data. However, the density of data points becomes sparser in the north of the project area, as the thickness of overlying strata increases and here the model becomes less reliable.

6.2.5 Base of New Pit Chalk Formation

The base of the New Pit Chalk has not been previously surveyed in East Kent, although the corresponding lithological change from hard nodular fossiliferous chalk to softer smooth white chalks has been noted in the coastal sections, and locally inland.

Thickness estimates for the Holywell Chalk and the New Pit Chalk in 18 paired determinations from borehole records suggest that in East Kent, Holywell Chalk formed between about 27 % and 38.6 % of the total. The average is 32.5 %. The base of the New Pit Chalk was therefore placed at a level corresponding to about two-thirds of the vertical interval between the revised base of the Holywell Chalk and the revised base of the Lewes Chalk, but constrained by the lithological and biostratigraphical data for individual localities.

In the field in East Kent, this level was commonly found to correspond with a distinct negative break of slope between a uniform steep slope above, and a more irregular, less steep slope below. This relationship was found both on the scarp face, as east of Wye [08 46] and in some dip-slope valleys, as near Hassell Street [086 471] and Drellingore [239 413]. Rock fragments in the soil are generally sparser on the New Pit Chalk outcrop than on the Holywell Chalk. These characters are consistent with landforms associated with the two formations in other parts of southern England. However, where the base of the New Pit Chalk lies near the top of the escarpment, as east of Wye [07 45] and north of Brabourne Lees [09 43], then the negative break of slope disappears.

Moreover, as the mapped line for the base of the New Pit Chalk follows that constructed for the base of the Lewes Chalk, it is subject to the same inaccuracies, thought to occur in some areas (Section 6.2.6). There could be significant inaccuracies in the shape of the outcrop pattern where it occurs beneath superficial cover on interflaves, or at the top of the escarpment. However, although these might affect the appearance of the geological map, because they occur at the 'feather-edge' of the outcrop, they are unlikely to influence the configuration of the 3D model to any significant extent.

The base of the New Pit Chalk can be identified on geophysical logs but is rarely recorded on lithological logs, and is not identifiable on seismic records. Thus there are relatively few reliable data points in the 3D model for this boundary.

6.2.6 Base of Lewes Nodular Chalk Formation

This approximates in form to the old Middle-Upper Chalk boundary, except that the base of the Lewes Chalk is taken significantly lower. During the original large-scale surveys of this area, the base of the Upper Chalk was placed at the lowest appearance of the distinctive *reussianum* fauna, which occurs in association with the 'Basal Complex' (Section 3.3.3). Numerous occurrences of the *reussianum* fauna are marked on field slips. In the field in East Kent, this level is commonly marked by a distinct positive break of slope.

The surveyed line for the base of the Upper Chalk is therefore probably fairly reliable in many places, although the accuracy with which it was mapped would be limited by its common occurrence in relatively steep, wooded ground, and by the less detailed contours shown on the old 1:10 560 scale maps. Also, in some places, at least (for example, south of Petham [128 502]) subsidiary positive features occur above the mapped base of the Upper Chalk, providing scope for confusion where the basal feature is obscured or not developed.

Furthermore, between the primary and secondary escarpments (Section 3.1), the interfluves are mostly flat-lying and covered by superficial deposits. Due to the sharpness of the incision of the valleys, they tend to be bounded by a positive break of slope, which resembles those marking the base of the Upper Chalk and the base of the Lewes Chalk. Thus where the base of these units converges with the edge of an interfluve, or lies across it beneath superficial cover, the line is much less reliable than where the boundary crops out on a valley side, or in an escarpment.

These factors seem to have led to significant error in at least one place, on the east side of the Alkham Valley [260 419]. Here, the base of the Upper Chalk was mapped at an altitude of about 110 m OD. However, small chalk pits about 100 m to the east at 120 m OD expose smooth white chalk typical of the New Pit Chalk (Section 7.4.8).

Before the new line marking the base of the Lewes Chalk was constructed, the existing line for the base of the Upper Chalk (i.e. the base of the *plana* Zone) was adjusted to be consistent with the modern five metre contour set, and with biostratigraphic and lithological observations. The base of the Lewes Chalk was then placed about 16 m below this revised base of the *plana* Zone (Section 3.3.3), bearing in mind any constraints by the lithological and biostratigraphical data for individual localities.

In the field, this line is found generally to coincide with a positive break of slope, typically at the top of the uniformly steep slopes underlain by the New Pit Chalk but locally with a negative break of slope below it. The base of the Lewes Chalk bears a similar relationship to associated landforms in other parts of southern England. Unfortunately, in at least one place, at Alkham [6270 4247] it seems likely that the positive feature marking the base of the Lewes Chalk was mistaken for the base of the Upper Chalk, which was mapped only about 5 m higher at this point (Section 7.4.8).

Moreover, as noted, there are probably significant inaccuracies in the mapping of the base of the Upper Chalk in some places. The newly constructed line for the base of the Lewes Chalk will be similarly inaccurate in those places, particularly where it occurs beneath superficial cover on interfluves. In some places the outcrop could extend too far south-west along the interfluves, perhaps by several kilometres. However, as with the New Pit Chalk, because inaccuracies in the mapping occur at the 'feather-edge' of the outcrop, they are unlikely to influence the configuration of the 3D model to any significant extent.

As discussed in Section 3.3.3, this boundary (or the base of the Upper Chalk) can be identified on lithological, geophysical and seismic logs.

6.2.7 Base of Seaford Chalk Formation

The base of the Seaford Chalk is here taken to coincide with the base of the *coranguinum* Zone. The generalised outcrop pattern of the biozones of the Upper Chalk in the Canterbury, Ramsgate

and Dover districts was deduced from biostratigraphic information gleaned from the many bedrock exposures and presented on small-scale maps in the corresponding memoirs (Smart et al., 1966, fig. 2; Shephard-Thorn, 1988, fig. 11).

These biozonal boundaries were constructed as a desk study. They were placed only by reference to information from exposures, and not by 'feature mapping' in the field, although due account would have been taken of geological structure and topography (Sections 3.3.4 and 6.2.1).

Lines from these small-scale diagrams were transferred to 1:10 000 base maps. Generalised structure contours were then drawn for the base of the *coranguinum* Zone, taking a generalised view of the outcrop and ignoring obvious inaccuracies. A revised boundary was then compiled, taking account of the original linework, the structure contours, locality information and the local topography.

This approach assumes a relatively low, uniform dip. In some places, faulting can be inferred from apparent displacements in the boundary. In others, for example at the south-eastern end of the Chatham Downs, north-east of Petham, faulting (or folding) is suspected but cannot be adequately demonstrated with the available information (Section 6.2.1).

In the field, this newly constructed line for the base of the Seaford Chalk was found generally to coincide with a distinct negative break of slope, as for example at Temple Ewell [285 446], Lydden [256 455, 260 456], Lower Hardres [1596 5300] and Bursted Manor [1675 5090]. The ground below and above this feature can have a uniform or a convex slope. Similar landforms are associated with the base of the Seaford Chalk elsewhere in southern England, although they are typically less well-marked than at these localities in Kent. However, in Kent this negative break of slope loses definition as the Seaford Chalk boundary converges with the edge of the interfluves.

The newly constructed line for the base of the Seaford Chalk will be most inaccurate where it occurs beneath superficial cover on interfluves. However, as with the New Pit Chalk and the Lewes Chalk, because inaccuracies in the mapping occur at the 'feather-edge' of the outcrop, they are unlikely to influence the configuration of the 3D model to any significant extent.

Although this boundary can be identified from geophysical logs, it is rarely recorded on lithological logs, and is not picked on seismic records. Thus there are relatively few underground data points. Accurate modelling of the corresponding surface is difficult.

6.2.8 Base of Margate Chalk Member

The base of the Margate Chalk is taken at the top of Barrois' Sponge Bed. This lies about 3 m below the base of the *socialis* Zone. The generalised outcrop pattern of the biozones of the Upper Chalk in the Canterbury, Ramsgate and Dover districts was deduced from biostratigraphic information gleaned from the many bedrock exposures and presented on small-scale maps in the corresponding memoirs (Smart et al., 1966, fig. 2; Shephard-Thorn, 1988, fig. 11).

As noted for the Seaford Chalk and in Section 6.2.1, these biozonal boundaries were constructed as a desk study. They were placed only by reference to information from exposures, and not by 'feature mapping' in the field, although due account would have been taken of geological structure and topography.

The new line for the base of the Margate Chalk was placed at a position about 3 m below the mapped base of the *socialis* Zone. In the field, this was found in some places to coincide with a weak to very weak negative feature, bounded above and below by gentle convex slopes. This feature is apparently not clearly defined at the top of the secondary escarpment, nor where it converges northwards with the valley floor, presumably because of superficial cover. The base of the Newhaven Chalk commonly occurs at a similarly faint negative topographic feature in other parts of southern England.

Lines from these small-scale diagrams were transferred to 1:10 000 base maps (Section 6.2.1). Generalised structure contours were then drawn for this line, taking a generalised view of the outcrop and ignoring obvious inaccuracies. The boundary was then revised, taking account of the original linework, the structure contours, locality information and the local topography.

This approach assumes a relatively low, uniform dip. In some places, faulting can be inferred from apparent displacements in the boundary. In others, for example between Whitfield and Ripple (1:10 000 sheet TR34NW) faulting (or folding) is suspected but cannot be adequately demonstrated with the available information.

Although this boundary can be identified from a few geophysical logs, it is not recorded on lithological logs, and is not picked on seismic records. Thus there are relatively few underground data points. Accurate modelling of the corresponding surface is difficult.

6.2.9 Base of Palaeogene

The base of the Thanet Sand Formation mapped during the original large-scale surveys remains essentially unchanged except for some minor modifications to maintain consistency with the modern five metre contours. However, it should be noted that in many parts, the basal contact is obscured by superficial drift deposits and is there likely to be less accurately surveyed. Furthermore, the contact is likely to be highly irregular locally, due to the presence of dissolution pipes in the underlying Chalk.

This surface is well constrained by data from borehole logs and by the complex shape of its outcrop pattern.

6.3 THE GEOPHYSICAL CHARACTERISATION OF THE CHALK GROUP IN EAST KENT

The interpretations of geophysical logs in this study are based on published research (Murray, 1986; Robinson, 1986; Mortimore and Pomerol, 1987; Mortimore et al., 2001) and, where available, examination of borehole core. This work also builds on previous detailed log correlations for the Chalk Group across southern England (Woods, 1999, 2000, 2001, 2002).

Technical aspects of geophysical logging are mentioned in Section 8.2, and its application to hydrogeological interpretation.

6.3.1 Base of Chalk Group

In the East Kent study area, where the Chalk Group overlies the Gault Formation, definition of the base of the Chalk solely on borehole geophysical evidence is problematical. The basal part of the Chalk Group is very argillaceous, and the low resistivity values corresponding to this lithology show negligible contrast with the underlying mudstones of the Gault. On gamma logs there is typically a progressive downhole increase in gamma values through the increasingly clay-rich lower part of the Chalk (Grey Chalk Subgroup), sometimes followed by a stepped increase in values within the purer mudstones of the Gault. Occasionally, a narrow peak in gamma log values occurs at the contact of the Chalk and the Gault, probably in response to concentrations of glauconite and phosphate at the base of the Chalk (Glauconitic Marl Member). In this study, the interpretation of boreholes containing the base of the Chalk Group has generally been guided by data from lithological logs.

6.3.2 West Melbury Marly Chalk Formation

On borehole resistivity logs, this formation is generally characterised by a serrated signature, with an upward trend of progressively increasing resistivity log values (Figure 4). Gamma log values are high compared to overlying formations in the Chalk Group, but lower than the

underlying Gault. A sharp peak in the gamma log may occur immediately above the base of the Gault (see above). The gamma and resistivity signatures reflect both the sedimentary rhythmicity of marl / limestone couplets that typify the West Melbury Marly Chalk, and the overall trend to decreasing clay content and increasingly dominant limestone towards the top of the formation.

6.3.3 Zig Zag Chalk Formation

The base of this formation is marked by a silty chalk horizon named the Cast Bed. As well as its distinctive lithology, the Cast Bed also contains diagnostic macrofossils that allow its recognition at outcrop and in borehole core. Where identified on resistivity logs from boreholes elsewhere in southern England (e.g. Berkshire Downs), this silty chalk typically corresponds to a distinct peak (Woods, 2001).

The Cast Bed has been identified in core from the Aycliff Borehole (Figure 5) and several other boreholes in the Dover-Folkestone area. Figure 5 shows that the horizon of the Cast Bed in the core is marginally above the peak that is taken to represent this horizon on the resistivity log. This discrepancy in the Aycliff Borehole is thought to be due to a slight mismatch in depths between the core and resistivity log.

Resistivity steadily climbs through the lower part of the Zig Zag Chalk, and some logs show a peak in values at about the middle of the formation (labelled 'Peak A' on Figure 4). By analogy with geophysical logs from elsewhere in southern England, it is possible that 'Peak A' represents Jukes-Browne Bed 7 (e.g. Murray, 1986, fig. 20), typically rather massive and more indurated than adjacent horizons.

6.3.4 Holywell Nodular Chalk Formation

A very sharp fall in resistivity log values coincides with the Plenus Marls Member, marking the base of the Holywell Nodular Chalk Formation and of the White Chalk Subgroup. This fall, combined with the equally abrupt rise in values shortly above that marks the strongly indurated Melbourn Rock (Figure 4), is very distinctive and easily recognisable on geophysical logs. Some detailed resistivity logs of the Plenus Marls show a small peak of slightly higher values within the Plenus Marls (Figure 4), possibly representing Jefferies' (1963) Plenus Marls Bed 3, which is more cemented than the rest of the member. On gamma logs, the Plenus Marls are marked by a narrow positive peak in values.

The remainder of the Holywell Nodular Chalk is characterised by relatively high resistivity, reflecting the hard, nodular lithology of this unit.

6.3.5 New Pit Chalk Formation

The overall low resistivity log values which characterise the New Pit Chalk Formation reflect the softer lithology compared to the underlying Holywell Nodular Chalk. Sharply defined resistivity lows probably represent the marl seams that are typical of this unit. Some can be consistently traced between boreholes and are matched with published marker-bed correlations (e.g. Glynde Marls, Mortimore and Pomerol, 1987; Figures 4 and 6-9).

The base of this formation is somewhat gradational and less consistently defined than the base of the Holywell Nodular Chalk; it coincides with an inflection in the resistivity log profile above which resistivity is much reduced (Figures 4, 7, 8).

6.3.6 Lewes Nodular Chalk Formation

There are relatively few resistivity logs for the whole of the Lewes Nodular Chalk in East Kent. An exception is the Lower Venson Farm Borehole, which is also cored, allowing lithological changes to be accurately matched with geophysical log patterns (Figure 6). In this borehole,

resistivity is slightly higher for the Lewes Nodular Chalk compared to the underlying New Pit Chalk, but not to the extent that might be anticipated by the generally hard, nodular lithology. Also, the log profile is more 'jagged' than for the New Pit Chalk, with longer and broader fluctuations between high and low values. The core shows that there are some horizons of softer nodular chalk, and low resistivity bands in the lower part of the formation represent a series of marl seams that correspond with sharp peaks on the gamma log and which can be recognised in other boreholes (Figure 7, 8).

On the log for Boughton Pumping Station Borehole (Figure 9), which also records the complete Lewes Nodular Chalk, the formation is more clearly represented by an interval of generally higher resistivity, and this is the trend suggested by borehole logs that incompletely profile the formation. However, boreholes close to the coast where the Lewes Nodular Chalk is affected by the presence of saline ground waters (e.g. Reculver 1 Borehole; Figure 10) show anomalously low resistivity through the formation. The key to the correlation of these coastal boreholes with those further inland has been the sharp gamma log peaks in the lower part of the formation, produced by what is almost certainly the same series of marl seams recognised in the Lower Venson Farm Borehole (see above; Figure 7, 8). The lowest and most pronounced of these marls is the Southerham Marl 1 of Mortimore (1986a) (Figures 6, 7, 10).

The base of the Lewes Nodular Chalk is generally taken to be at a small positive peak in resistivity, a few metres below the resistivity low formed by Southerham Marl 1 (e.g. Figures 4, 6, 7-9).

6.3.7 Seaford Chalk Formation

The Seaford Chalk is generally characterised by lower resistivity log values than the underlying Lewes Nodular Chalk, reflecting reduced hardness. In the Reculver boreholes the resistivity logs are anomalously low (especially in Reculver 1) due to the influence of saline ground water near the coast (Figures 10, 11).

The base of the formation is defined by the upward change to lower resistivity log values and by the inferred horizon of East Cliff Marl 2, the correlative of Shoreham Marl 2 that marks the boundary of the Lewes Nodular and Seaford Chalk formations in Sussex (Mortimore, 1986a; Robinson, 1986; Mortimore, 1987). Macro- and microfossil data (Wilkinson, 2003) from the Lower Venson Farm Borehole suggests that this boundary may be at about -23 m OD in that succession, and the corresponding signature of the resistivity log at this OD has been used to assist with interpreting the base of the Seaford Chalk in other boreholes (Figures 6-9).

6.3.8 Newhaven Chalk Formation (Margate Chalk Member)

The Newhaven Chalk is very tentatively identified at the top of the Chalk Group in the Reculver boreholes (Figures 10, 11), and it may also be the youngest chalk in a borehole at Woodnesborough [3002 5663]. In the Reculver boreholes, this interpretation is based on a small but distinct fall in gamma log values above -40 m OD, which may signal the presence of the typically marl free Margate Member of the Newhaven Chalk Formation (Robinson, 1986; Mortimore et al., 2001). Elevated gamma values for a few metres below -40 m OD could be connected with the development of the Barrois Sponge Bed, which occurs at the top of the Seaford Chalk in East Kent (Robinson, 1986; Mortimore et al., 2001).

Alternatively and more speculatively, a peak in the resistivity log at about -45 m OD in the Reculver boreholes could also represent part of the Barrois Sponge Bed, although the signature is of questionable significance given the likely effects of saline ground water. In the top of the borehole at Woodnesborough very low resistivity chalk (? Newhaven Chalk) overlies a resistivity peak (? Barrois Sponge Bed).

6.3.9 Top of Chalk Group

In some boreholes (e.g. Reculver 1, Reculver 2; Figures 10, 11), a very sharp increase in gamma log values signals the presence of argillaceous Palaeogene and Drift deposits overlying the Chalk Group. Piping of cover strata into the top of the Chalk Group may be indicated by the peak in gamma values immediately below the interpreted top of the Chalk Group in the Reculver 1 and Reculver 2 boreholes.

7 Structure

7.1 GENERAL CONSIDERATIONS

Tectonic activity during deposition has influenced the thickness of the Chalk succession and its lithological composition on a local or regional scale. There is growing evidence that tectonic and eustatic movement occurred in phases throughout the Upper Cretaceous (Mortimore and Pomerol, 1987, 1991; Mortimore et al., 1998; Evans and Hopson, 2000). Four major tectonic phases (demonstrated in Germany and in the eastern Anglo-Paris basin) caused local channelling and slumping, and the local formation of hardgrounds and phosphatic chinks, as well as variations in marl seam development throughout southern England. Some characteristics of the Chalk in the present area may be a consequence of this tectonic activity. Also, some lateral changes in stratigraphy and some local structures in the Chalk can be related with structures observed in the underlying Palaeozoic rocks (Shephard-Thorn et al., 1972; Shephard-Thorn, 1988; Wood et al., 1996).

In some parts of southern England, faulting within the formations beneath the Chalk becomes attenuated upwards, apparently passing into broad anticlinal folds. Where faulting does occur in the Chalk, the displacement may have been accommodated by movements of numerous small faults within a zone some tens, perhaps hundreds, of metres wide, rather than on a few discrete fault planes. In unexposed Chalk terrain, it is rarely possible to distinguish a broad, gentle anticlinal fold from a broad fault zone. Indeed, it is difficult to demonstrate the unequivocal existence of faults in unexposed Chalk by geological field survey unless the faults are relatively large.

This inherent ambiguity has led to caution in the depiction of faults on maps of the Chalk published by BGS: in general faults have been shown only when their presence is beyond dispute. Unfortunately, this caution may have led to situations in which faults have been disguised by over-generalisation of outcrop patterns consistent with the belief that no significant faulting is present.

A less cautious approach was deliberately adopted during the compilation of the new map of East Kent: linear zones of displacement have been interpreted as faults, by preference, rather than regarding them as the possible consequence of folding. This preference is justified by the general style of the linear zones (they are narrow, and laterally persistent), by their association with truncated and offset landforms, and with fractures observed in exposed chalk. The presence of many of the faults inferred from surface data was substantiated by subsurface data.

Indeed, the difficulty in distinguishing between the effects of folding and faulting is probably not of critical importance in the context of the East Kent Project. Many of the faults shown on the geological map probably mark vertical displacements of less than 5 m, say, but even so it seems likely that such faults mark zones of anisotropy within the aquifer. It seems likely that in most local folds the Chalk will have undergone some brittle fracture and sufficient minor faulting to influence the local hydrogeology.

In the same way that small faults and folds at outcrop will remain undetected by field survey of the widely-spaced, coarse topographic features delineating the relatively thick Chalk formations, the relatively sparse distribution of subsurface data does not allow the delineation of any but the most obvious structures in the 3D model. The wavelength of small to medium-scale folds in the Chalk is less than the general spacing of the boreholes in the area.

Three classes of fault are shown on the new geological map of East Kent which accompanies this report.

- Faults shown as full (unbroken) black lines are those inferred from outcrop information. A few of these were identified during the original field survey, but most became apparent during the manual construction of structure contours for successive surfaces. Most were subsequently corroborated by modelling of subsurface information.
- Faults shown as pecked (broken) black lines are those inferred from subsurface information alone. Some might be confined to subsurface layers.
- Faults shown as magenta lines are classed as 'speculative'. Their existence is inferred from the general appearance of outcrop patterns, from the presence of topographic lineaments, or from offsets or changes in landscape 'texture', but without specific evidence for the displacement of geological boundaries. Their occurrence and position are more subjective than for the other two classes.

The evidence for some individual faults is discussed in subsequent sections.

As with all geological maps, that which accompanies this report is an interpretation of information available at the time of compilation. It is felt to represent a reasonable position between 'cautious under-interpretation' and 'ambitious over-interpretation'. Other interpretations of the same information are possible, although it is thought likely that the differences compared with the present interpretation would be in matters of detail. Consideration of the significance of the detail of the present map should bear this in mind.

No evidence has been noted from field observation, borehole records, mapped outcrop patterns or 3D modelling for either cambering of the Chalk escarpment or valley bulge within the subjacent Gault. It is conceivable that such superficial structures do occur in places, but if so their size is apparently insufficient to influence the local outcrop patterns or the configuration of the geological model.

7.2 REGIONAL STRUCTURE

There are several relevant published descriptions of the regional tectonic structure. These differ in emphasis, according to the type and location of the structures studied.

According to Warren and Harris (1996), three phases of tectonic activity affect the structural setting of the English Channel adjacent to Kent: Variscan (Permo-Triassic), Cimmerian (Late Jurassic to Early Cretaceous), and Alpine (mid-Tertiary).

It has been suggested that some Variscan structures, chiefly NW-SE trending faults and monoclines, were reactivated during subsequent deformation (Robaszynski and Amedro, 1986; Shephard-Thorn, 1988; Warren and Harris, 1996). It has also been suggested that the E-W folding to the north of the Kent coalfield in the Isle of Thanet area represents a perpetuation of Variscan structures of this orientation in the London area (Rippon et al., 1997).

In late Jurassic times, Cimmerian crustal extension reactivated NW-SE faulting in both East Kent and the Boulonnais, forming a sub-Cretaceous graben near Tilmanstone (Warren and Harris, 1996).

Mid-Tertiary folding and faulting follows an E-W trend in the Weald, turning to NW-SE in northern France. Within the Channel Tunnel project area, folding has a WNW-ESE trend. Two

anticlines (including the Dover Anticline) and an intervening syncline were found to displace the West Melbury Chalk, as well as some minor folds. Their amplitude at that stratigraphic level appears not to exceed about 5 m. In the UK sector of the tunnel, there is evidence for post-Cretaceous reactivation of Variscan structures but faulting was generally minor, with recorded displacement exceeding 3 m in only one case. Most jointing recorded by the Channel Tunnel project follows the same WNW-ESE trend as the faulting, with strong NE-SW joints at one locality (Warren and Harris, 1996).

Bergerat and Vandycke (1994) identified three fault systems from outcrop studies in the Cretaceous and Palaeogene strata of East Kent. The earliest is a conjugate system of NW-SE dextral and NNE-SSW sinistral faults, found only in Cenomanian formations (the Grey Chalk subgroup) and taken to indicate N-S compression with E-W extension. This was related to inversion on major fault zones of Variscan trend to the south. The second, a conjugate system of N-S trending normal faults, is attributed to post-Turonian E-W extension (perhaps also partly in Late Cenomanian time). This was suggested to be linked with Tertiary extension in the Rhine Graben. The third set, comprising NW-SE normal faults, is the most numerous. It has been identified over a wide area of England and France and shows evidence for reactivation of the Variscan trend over a considerable period, possibly continuing into the Quaternary (Bevan and Hancock, 1986). Bergerat and Vandycke (1994) also noted the presence of NNE-SSW to NE-SW trending faults in the offshore area near Kent.

It has been suggested that Cretaceous sedimentation in north-west France was controlled locally by the relative movements of tectonic blocks bounded by faults with two main orientations: N030° and N110° - N120° (Robaszynski and Amedro, 1986). A broadly similar fault pattern is found in East Kent. The coal basin in the Boulonnais is divided into several sections by normal faults trending N030° (Wood et al., 1996).

7.3 REGIONAL DIP AND FOLDING

7.3.1 Regional dip

Within the project area, geological modelling shows that the Chalk generally dips at 1° or less, with steeper dips occurring locally in the vicinity of faults and folds. The dip direction is typically to the north-north-east (N025°), confirming the conclusions of earlier works (Shephard-Thorn, 1988; Birch and Warren, 1996). Eastwards, near the coast, the dip direction is commonly more towards the north-east (N040°). In some areas in the west, it turns to a more northerly direction, particularly within the Stour Valley Fault Zone (Section 7.4.2) south of the secondary escarpment. Strike directions also turn to an east-west orientation near the edge of the Palaeogene outcrop between Wingham and Eastry, continuing northwards into the Isle of Thanet.

Strata dipping more steeply than, or in a direction contrary to, the regional dip may be observed in some exposures. For example, a weak southerly dip was noted in a chalk pit east of Stelling Minnis [164 478]. Reynolds (1948) found the Chalk in adits at Terlingham and Drellingore to dip to the east, rather than the north-east. In some cases, these apparently anomalous dips probably reflect proximity to some local structural feature, not necessarily one identified by the geological model.

Superimposed on this overall pattern, there is evidence for folding on axes approximately perpendicular to the regional dip, as shown on the geological map and discussed in the following sections.

Smart et al. (1966) also observed that the regional dip of the Chalk is locally varied by minor folding. These local folds were described as monoclinical and north-facing, with axes trending north of west, or as gentle anticlines with axial trends south of west. The presence of these folds was inferred from mapping of the traditional tripartite divisions of the Chalk, on basemaps with

relatively poor topographic detail, and no account appears to have been taken of possible faulting in the same areas. In most cases, no clear evidence for this folding emerged when structure contours were constructed using modern large-scale topographic maps, with 5 m contour sets. Nevertheless, details of these inferred folds are noted in the following two sections.

7.3.2 Strike-parallel folds

In the north-east of the area, the Richborough Syncline trends approximately east-west between Canterbury and Pegwell Bay. Geological modelling of the basal Palaeogene surface suggests that the western portion of the synclinal axis is offset southwards along a series of NNE-SSW trending faults, terminating near the Great Stour. An alternative interpretation presented by Holmes (1981, fig. 2) implies that it might instead turn to a west-north-westerly direction in the vicinity of Hersden.

The complementary Thanet Anticline lies a few kilometres to the north. The short limb of this south-facing asymmetric fold pair dips gently southwards, probably at no more than about 5°. Construction of structure contours for the biozonal boundaries compiled by Shephard-Thorn (1988, fig. 11) implies that the anticlinal axis is offset northwards in the vicinity of Manston. There is insufficient information to show whether this is a consequence of *en échelon* folding or faulting. To the north of the Thanet Anticline, the Chalk dips in a northerly direction at less than 1°. The monoclinical southern limb of the Thanet Anticline seems to have formed above a fault between Lower Palaeozoic rocks to the north and possible Devonian rocks to the south (Shephard-Thorn, 1988, p.32).

Previous work has noted the occurrence of several WNW-ESE-trending folds close to the coast between Folkestone and Dover, including the Dover Anticline on whose north-east limb the dip increases to 2° (Birch and Warren, 1996). Geological modelling shows the Dover Anticline most clearly at the base of the Holywell Chalk (there seems to be too little data to define it in the older formations) and suggests that it dies out upwards. Only gentle changes of dip corresponding to the Dover Anticline are seen in the cliff section (Acer Consultants Ltd, 1991, p. 32) which there exposes the New Pit Chalk and the Lewes Chalk. The amplitude of the other folds near Dover appears to be less than 5 m, and there is insufficient subsurface information for them to have been resolved within the 3D model.

Smart et al. (1966, p. 13) considered that between the Stour valley and the valley east of Stelling Minnis, the northerly regional dip of the Chalk is interrupted by two gentle folds, separated by broad areas where it is horizontal or dips gently to the south. No evidence for this interpretation was found during the present project.

7.3.3 Dip-parallel folds

Evidence for linear zones of displacement on axes approximately parallel to the regional dip is seen in offsets of major topographic features, such as the secondary escarpment, and of structure contours. As discussed in Section 7.1, the effects of folding and faulting can be difficult to distinguish. In the present area, linear zones of displacement have been attributed to faulting, as described in the following section.

Smart et al. (1966, p. 11, 13) considered that a gentle syncline whose axis trends about N030°, probably occurs along the Great Stour valley near Kennington, perhaps continuing to near Crundale. They also noted a weak anticlinal warp 'along the upland 1.25 miles east of Wye', which dies out northwards. Another syncline is said to coincide approximately with the Petham valley and a third embraces the valleys through both Lynsore Court [164 488] and Dane Farm [176 479]. The presence of these structures could not be corroborated during the present project.

7.4 FAULTING AND FRACTURING

In common with other Chalk terrains in southern England, very few faults were recognised within the project area at the time of the original large-scale survey. Those which have been identified previously are mostly of no great extent, and occur either along the scarp face (or the base of the Gault nearby), at the coast, or in the Isle of Thanet.

Although many of the coastal cliff sections and chalk quarries expose faults, the majority of these have displacements of five metres or less, and they cannot be traced beyond the exposure. Although the common occurrence of minor faulting of this kind in exposures suggests that it may be a ubiquitous feature of the Chalk, especially in the harder Chalk units, such as the Holywell Nodular Chalk and the Lewes Nodular Chalk formations, it is rarely possible to demonstrate the existence of faults of less than five metres displacement in unexposed ground on the Chalk, even during detailed field surveys.

During this project, however, manual construction of structure contours for the mapped outcrops of the base of the Palaeogene, and of the Margate Chalk, the Seaford Chalk, the Lewes Chalk, the Holywell Chalk and the West Melbury Chalk suggest the presence of numerous previously unrecognised faults. Structure contours were also constructed for the base of the *testudinarius* Zone within the Margate Chalk on the Isle of Thanet (Shephard-Thorn, 1988, fig. 11).

For the most part, the occurrence and orientation of these faults has not been tested by fieldwork. Where the existence of the faults has been inferred from subsurface data, it is accepted that the fault does not necessarily reach the surface and the outcrop patterns shown on the geological have not been adjusted to show the inferred displacement.

7.4.1 Fault patterns

Other than in the Isle of Thanet, most fault orientations in East Kent can be treated in two broad groups: NE-SW (including a subset oriented NNE-SSW) and WNW-ESE. The same principal fault alignments were found in the Channel Tunnel Project area (Sharp et al., 1996), in northern France (Robaszynski and Amedro, 1986) and, amongst other trends, at outcrop in Kent (Bergerat and Vandycke, 1994). In addition, NNW-SSE faults occur locally, particularly in a zone to the west of Canterbury. Fault trends on the Isle of Thanet are less clearly defined, including E-W, NW-SE and N-S elements.

Linear zones of displacement of similar orientation occur in North Kent, but the frequency and intensity of faulting on both main trends increase markedly across the Great Stour valley. Apart from the contrast in density of mapped faults, this structural change is also revealed by a considerable difference in the outcrop patterns (Figure 12). Between the River Medway and the River Great Stour, the Chalk escarpment is broadly linear, with no re-entrant valleys. The base of the Lewes Chalk follows the top of the escarpment and the Seaford Chalk is minimally dissected. From the Great Stour eastwards, the primary escarpment has a complex shape, with several major re-entrants. Mostly, the base of the Lewes Chalk occurs on the dip slope at some distance from the escarpment, and the dip slope is considerably dissected; the Seaford Chalk forming several large outliers.

7.4.2 Stour Valley Fault Zone

The change in structural style between North Kent and East Kent occurs across a NE-SW-trending linear zone, between about 3 km and 5 km wide, encompassing the eastern valley side of the Great Stour between West Stourmouth and Wye, and extending south-eastwards to the lower Nailbourne valley, and a line through Bridge, Petham, Waltham and Brook (Figure 12). It is apparent from a small-scale geological map that the outcrops of the Palaeogene and the Seaford Chalk undergo considerable offsets across this Stour Valley Fault Zone. The secondary escarpment (and the outcrop of the Margate Chalk) are offset to a similar extent at the eastern

side of the zone, and are cut out at its western side. The western extent of the Margate Chalk outcrop thus appears to be structurally controlled.

The Stour Valley Fault Zone is formed by three intersecting sets of faults. The dominant elements appear to be NE-SW trending. These are intersected and partly offset by a NNE-SSW trending set, particularly on the south-eastern side of the zone, and partly by a NNW-SSE trending set, particularly on an axis through Chilham. This NNW-SSE fault zone is marked by a major change in the orientation of the Great Stour valley, and by two subparallel valleys south-east of Crundale, 'hidden' just behind the escarpment near Wye.

The presence of this fault zone along the Great Stour Valley appears to have been previously unsuspected. This is presumably because its form is disguised by the intersection of several sets of faults, and particularly by the NNW-SSE-trending offset aligned with Chilham. Indeed, most of the component faults had not previously been mapped, and even now are fairly weakly defined. The existence of some remains speculative.

The presence of a set of 'speculative' faults of this orientation between Bekesbourne and Waltham is inferred in part from the considerable offset in the secondary escarpment, the base of the Seaford Chalk and the base of the Palaeogene, and in part from the topography, particularly a zone of anomalous drainage patterns between Bridge and Petham. It is to some extent corroborated by local anomalies in the outcrop pattern of the Seaford Chalk. However, the latter is based on the mapped outcrop of the *coranguinum* Zone, itself a medium-scale desk compilation which assumed no displacement by faulting.

In the southern end of the Stour Valley Zone, south of the secondary escarpment, the regional dip direction changes from north-north-east to north, and the pattern of linear valleys alters (Section 7.4.7). The eastern extent of this area of north-dipping strata is ill-defined. It is possibly controlled by series of NE-SW and NNE-SSW trending faults, in a continuation of the pattern indicated along the south-eastern side of the Stour Valley Zone north-east of Petham, but there is insufficient evidence on which to construct them. Instead, only a single speculative line of faulting is shown, through Petham and Waltham.

The marked change in structural style between the Chalk outcrops of North Kent and of East Kent, and of the apparent structural control of the Margate Chalk, strongly implies that the Stour Valley Zone marks some basement structure. It is possible that the same structure controls the poorly known western margin of the East Kent Coal Measures subcrop, at least in part. Reasonably close constraint by borehole records places this margin between Harmansole and Bishopsbourne, where it lies close to the south-eastern margin of the Stour Valley Zone. Conversely, the Coal Measures do subcrop to the north-west of the fault zone at Hoades Court and Rushbourne (Holmes, 1981, fig. 3), and their western margin apparently lies east of Brabourne, just to the south of the Chalk outcrop (Smart et al., 1966, p. 9).

No displacement in alignment with the Stour Valley of the Lower Cretaceous formations near Ashford has been noted. Further to the south-west, however, the Stour Valley Fault Zone is approximately aligned with the linear western margin of Romney Marsh, a previous coastline between Appledore and Winchelsea, and with the Hastings area, where a swarm of NNE-SSW faults intersects with the more widespread faulting parallel to the Wealden anticlinorium.

7.4.3 Other NE-SW and NNE-SSW faulting and fracturing

Geological modelling of the East Kent area, using both outcrop information and subsurface data, reveals the presence of numerous faults oriented between NE-SW and NNE-SSW. The existence of some of these has been inferred in some previous work by hydrogeologists and water engineers (Acer Consultants Ltd, 1991), but their number, extent and magnitude seems to have been unsuspected.

The most obvious fault zone on this trend forms a graben between Densole and Eastry. The south-eastern bounding fault coincides with the Lydden valley and is apparently responsible for a sinistral offset of about 500 m in the secondary escarpment. (It approximately coincides with the south-eastern edge of Domain 3, see Section 7.4.7). According to the geological model, the base of the Seaford Chalk is vertically displaced by only about 5 m, but much greater displacements are indicated for the older chalk formations. The distribution of linear valleys (Section 7.4.7) suggests that differential rotation of the blocks either side of this fault-zone has occurred, implying some element of strike-slip displacement.

The north-western side of this graben is formed by a series of subparallel faults on a similar trend, each down-thrown towards the south-east. Several dextral offsets in the secondary escarpment are apparent, although not all correspond to mapped faults, suggesting that the fault pattern on the western margin of the graben is more complex than shown.

A subsidiary NE-SW trending graben occurs between Wingfield and Ripple.

The 'two-pronged' shape of the Tilmanstone saline contamination plume suggests a measure of control by NE-SW trending fractures (Headworth et al., 1980, p. 109). The north-westerly 'prong' lies within the northern end of the Densole-Eastry graben; the position of the other suggests that a subparallel fracture zone occurs near Northbourne, although no fault on this trend has been detected there.

The mean orientation of the dry valleys in the Folkestone-Dover area (N060°-N240°) corresponds to the regional joint trends observed in the cliffs nearby (Birch and Griffiths, 1996).

7.4.4 NW-SE faulting and fracturing

Faults of this orientation are found in the Palaeozoic strata of the East Kent coalfield, and it is thought that NW-SE faults in the Chalk represent reactivation of the older structures (Shephard-Thorn, 1988). Subsurface modelling suggests that NW-SE faulting in the Coal Measures has propagated upwards into the Chalk near Northbourne, and in a zone between Goodnestone and Chislet, although in the latter the faults modelled in the Chalk lie at a more northerly azimuth (by some 20 to 25°) than those shown to occur in the underlying Coal Measures (Shephard-Thorn, 1988, fig. 5). A minor NW-SE valley west of Deal seems analogous to the Dour Valley (discussed below), but there are no known coincident faults in the Betteshanger Colliery or in the Chalk.

A narrow NW-SE trending graben in Jurassic strata between Tilmanstone and Betteshanger apparently did not influence later structures.

NW-SE faulting occurs in the cliffs between Folkestone and Dover but none exceeds 4 m displacement. One fault, 220 m west of the Abbotscliffe Tunnel eastern portal downthrows 3.6 m to the NNE, and another, 450 m west of the same portal downthrows 1.5 m to the NE. The latter fault is thought to be responsible, in part, for the emergence of the Lydden Spout spring (Birch and Warren, 1996). The dominant joint sets dip between 60° and 70°, striking WNW-ESE, between N110° and N130°. In the cliffs, some joints are seen to close-off where they penetrate relatively clay-rich chalks of the Grey Chalk Subgroup.

It has been postulated that a set of large scale discontinuities on this trend intersect the coast between Dover and Folkestone at intervals of 1.0 to 1.5 km, extending inland for 10 km or more. Evidence of a series of NW-SE fractures near Dover is provided by a number of springs within the cliffs (such as the Lydden Spout) (Reynolds, 1948) and by hydrogeological and geomorphological features inland (Birch and Griffiths, 1996). Flow at the Lydden Spout Spring has diminished following pumping at Lower Standen and Drellingore (Reynolds, 1948). However, the emergence of these postulated NW-SE features at the cliffs is not always accompanied by dislocations in the bedding.

Reynolds (1948, p. 108) recorded the presence of faults in the Chalk intersected by adits driven from wells near Drellingore in the upper Alkham valley. These faults were generally oriented N130°, but some ran nearly N-S. Other local details of faulting in the Alkham valley are discussed in Section 7.4.8.

The NW-SE (N125°) trending portion of the Dour Valley is approximately coincident with a possible fault in a relatively steeply dipping part of the Coal Measures subcrop (Shephard-Thorn, 1988, fig. 5). This part of the Dour Valley has been inferred to mark a fracture zone in the Chalk, which can apparently be traced out to sea as a zone of deeply weathered chalk (Shephard-Thorn et al., 1972) although this interpretation has been placed in doubt by subsequent, more detailed, work (Sharp et al., 1996). Shephard-Thorn (1988, p. 31) found no evidence for vertical displacement of the base of the Upper Chalk across this Dour Valley fracture zone and suggested that post-Cretaceous movements were strike-slip, rather than dip-slip.

However, subsequent work by R N Mortimore suggested that the Dour Valley Fault has a downthrow to the south-west of about 30 m near Temple Ewell (Acer Consultants Ltd, 1991). Furthermore, structure contours on the base of the Seaford Chalk demonstrate a similar displacement in the sector south-east of Temple Ewell. It therefore seems likely that the base of the Upper Chalk was mapped inaccurately in at least part of the built-up area of Dover.

It is possible that the Dour Valley Fault zone continues to the north-west of the Lydden Valley, forming a bounding structure at the foot of the secondary escarpment. There is little evidence for such a structure between Lydden and Bridge, apart from the presence of a large linear valley through Barham and Kingston, although displacement of the escarpment on NE-SW faults (probably more extensive than shown on the map) has possibly obscured it. A bounding fault zone, subparallel to the Dour Valley, has been inferred at the foot of the Chartham Downs from local outcrop patterns and changes in the pattern of local valleys (Section 7.4.7).

7.4.5 NNW-SSE faulting and fracturing

A zone of NNW-SSE trending faults on an axis through Chilham was discussed in Section 7.4.2. This offsets the Stour Valley Fault Zone, close to its possible south-west termination.

The existence of a subparallel zone between Goodnestone and Chislet is indicated by modelling of subsurface data. This occurs near the north-eastern end of the Stour Valley Fault Zone.

7.4.6 Faulting and fracturing in the Isle of Thanet

Fault trends on the Isle of Thanet are less clearly defined than elsewhere in the project area, including E-W, NW-SE and N-S elements. They have been described in a general sense as tensional structures related to the formation of the Thanet Anticline (Shephard-Thorn, 1988).

Fracture analysis suggests that the Thanet Anticline is crossed by a WNW-ESE fold. Fracturing of the Chalk is thought to have commenced during a syn-depositional extensional tectonic phase. This was followed by late Cretaceous to Palaeogene N-S horizontal compression which is thought to have caused inversion of basement faults. Late fracturing accompanied uplift and unloading (Ameen, 1995).

7.4.7 Slope aspect analysis

East Kent project: slope aspect and topographic lineament analysis

It is commonly found that valleys in Chalk downlands mark zones of higher transmissivity and storage coefficient than the adjacent interfluvies (Allen et al., 1997; Jones and Robins, 1999). Although these properties are also influenced by other factors (Allen et al., 1997, p. 31), linear downlands valleys can be supposed to mark steeply dipping or subvertical fracture zones within the Chalk. Analysis of the pattern of linear valleys can thus be expected to provide information

about some, at least, of the fracture sets present in the area (Birch and Griffiths, 1996). For example, the mean orientation of the dry valleys in the Folkestone-Dover area (N060°-N240°) corresponds to the regional joint trends observed in the cliffs nearby. These fracture zones may have a significant influence on water movement within the aquifer, even though faulting within them may be minor in terms of vertical displacement.

Slope aspect analysis of a digital terrain model has been found to provide a useful means of identifying linear topographic elements in an area (Bloomfield, 1999, 2000). For the present study in East Kent, this was undertaken for two reasons. Firstly, simply to describe the distribution (in terms of both position and orientation) of the linear valleys in the area. Secondly, to assist in structural interpretation of the area, by providing a means of testing for relative movement between adjacent blocks, known or suspected to be separated by faults.

For structural interpretation, analysis of slope aspect (the direction in which a slope faces) is preferred to analysis of shaded relief models. Although structural lineaments commonly extend across more than one topographic feature (for example, minor side valleys in adjacent major valleys could be associated with the same lineament) it is more difficult to see such correlations on shaded relief models than on colour-coded slope aspect maps. Moreover, the illumination direction chosen for a particular shaded relief model can enhance or subdue the appearance of lineaments depending on their azimuth. Colour-coded aspect maps can also serve to highlight larger areas dominated by similar facing directions, that might be related to regional dip or other structural patterns.

Slope aspect analysis was performed on the Ordnance Survey Landprofile digital topographic data, using the 3D Analyst extension to Arcview 3.3 (Figure 13). Initial appraisal shows that most linear valleys in East Kent are oriented approximately NE-SW or NW-SE, rather than N-S and E-W. Slopes were therefore classified according to their aspect in the four quadrants, N000° to N090°, N090° to N180°, N180° to N270° and N270° to N000°. In Figure 13, the north-easterly facing quadrant has been left uncoloured to leave portions of the base map visible.

Two separate and independent interpretations (by different individuals) were made of this slope aspect analysis, using slightly different approaches. The first interpretation classified all lineaments in the same way, regardless of length, and analysed them by subdivisions identified according to geological criteria (Figure 14). The second identified a hierarchy of lineaments based on topographical criteria, and used the major lineaments to subdivide the area (Figure 15). The results from each approach are broadly similar but as they possibly serve to emphasize different aspects of the local geological structure, both interpretations are presented here. (The slope aspect analysis and the lineament maps form part of an Arcview project collating numerous digital datasets from the East Kent Project.)

In each case, the orientation of lineaments was analysed statistically, using the computer programme EZ-ROSE. This programme is designed for unimodal azimuthal data. Many of the rose diagrams show a bimodal or trimodal distribution of lineaments, as would be expected in natural fracture sets. The probable peaks in the azimuthal distributions were therefore identified visually.

Subdivision by geological criteria

For the first interpretation, all obvious linear valleys were identified by visual inspection and marked manually on a copy of the slope aspect analysis. The valley lineaments so identified were then grouped into structural domains subdividing the Chalk outcrop east of the River Great Stour according to geological outcrop patterns and the position of inferred faults (Figure 14). Rose diagrams showing the azimuthal distribution of the lineaments are shown in Figure 16, and statistics summarised in Table 4.

All domains

Taken together, the linear valleys of East Kent have a mean orientation of about N040° ± about 5°, reflected in a NE-SW peak in the data distribution (Figure 16A). (Confidence limits are quoted at the 95% level throughout). There is an additional tendency for other valleys to be oriented between N and ENE, but no subsidiary clusters. This is probably a consequence of the marked differences between individual domains, as discussed in the following.

Domain 1

This lies between the primary and secondary escarpments, and within the five kilometre-wide zone of faulting inferred alongside the Great Stour valley (Section 7.4.2).

Statistical analysis found no single preferred orientation amongst the lineaments: instead there appear to be three poorly-defined peaks approximately NE-SW, ESE-WNW and N-S (Figure 16B).

Domain 2

This lies north of the secondary escarpment, and within the five kilometre-wide zone of faulting inferred alongside the Great Stour valley (Section 7.4.2).

There is a strong N-S preferred orientation in this domain, possibly resolvable into NNE-SSE and NNW-SSE elements, with a weak subsidiary NE-SW trend.

The differences between Domains 1 and 2 seem to support an interpretation of a bounding structure at the southern foot of the Barham Downs, a presumed north-western continuation of the Dour Valley fault zone (Section 7.4.4). The structural identity of Domain 2, and the presence of a bounding structure along the Barham Downs, is also supported by the alternative interpretation (Figure 16C).

Domain 3a

This lies between the primary and secondary escarpments, and between inferred fault zones near the Great Stour valley and along the Lydden valley (Sections 7.4.2 and 7.4.3).

Peaks in distribution occur in NE-SW (N035°), ENE-WSW and ESE-WNW orientations. The mean vector, at N046°, is correspondingly short with relatively broad confidence limits (Figure 16D).

Differences in the lineament pattern between Domain 1 and Domain 3a suggest that they are likely to be separated by fault zones, although there no well-defined major topographic lineament between them.

Domain 3B

This lies north of the secondary escarpment, and between inferred fault zones near the Great Stour valley and between Eastry and Lydden (Sections 7.4.2 and 7.4.3).

The main peak in distribution is the same as in Domain 3a (N035°) (Figure 16E). One of the subsidiary peaks is similar (ENE-WSW) but it is barely defined by these data. The mean vector is thus close to the main peak and is relatively long, with narrow confidence limits. The main difference between Domains 3a and 3b is the lack of ESE to SE-trending linear elements in 3b.

This difference could be taken to support the concept of the Dour Valley fault zone, and its north-western continuation, as a bounding structure, but the difference is slight and there are indications of faulting passing from Domain 3a into Domain 3b.

Differences in the lineament pattern between Domain 2 and Domain 3 suggest that they are likely to be separated by fault zones, a concept supported by the presence of a major topographic lineament between them.

Domain 4

This lies between the primary and secondary escarpments, and east of the inferred fault zone along the Lydden valley (Section 7.4.3).

The strongest peak (N055°) is close to the mean vector (N058°). A fairly distinct subsidiary SE-NW peak (N130°) occurs at a 75° angle to the main trend (Figure 16F).

Compared with Domain 3a, the mean vector apparently differs by 12°, but the confidence sectors overlap by almost as much, so there is probably no significant difference in this respect. However, Domain 3a has two relatively strong trends separated by an angle of 80°, similar to the situation found in Domain 4, but the relative orientation of these two pairs differs by 20°. This observation supports the concept of a bounding structure along the Lydden valley, along which relative rotation of Domain 3a and Domain 4 has occurred.

Domain 5

This lies north of the secondary escarpment, and between inferred fault zones between Eastry and Lydden (Section 7.4.3).

The main peak of distribution (N040°) is, as in Domain 4, very close to the mean vector azimuth (N039°) (Figure 16G). There are possibly three subsidiary peaks, N-S, E-W and ESE-WNW. The last, at N115°, lies at 75° to the main trend, giving a similar pattern to that found in Domain 3a, and likewise differing from that in Domain 4 by a relative rotation of 15°. The differences in fracture distribution and in relative misalignment support the interpretation of the Dour Valley as marking a fault zone.

The mean vector alignment in Domain 3b and Domain 5 differs by only 6°, well within the 95% confidence limits. The peaks seen in Domain 3b also occur in Domain 5. Lineament analysis provides no support for the presence of a fault zone between Eastry and Lydden (inferred from other data), indicating that no relative rotation has occurred between these two structural blocks.

Domain 6

This comprises the Chalk of the Isle of Thanet.

A fairly broad spread of lineament orientation is found, with apparent peaks in N-S, E-W and SE-NW orientations (Figure 16H). This pattern is dissimilar to that found in any other domain, consistent with its proximity to an E-W fold axis.

Topographic subdivision

For the second interpretation, the topographic lineaments were analysed as a hierarchy. In the analysis of regional-scale digital terrain models it is commonly possible to identify (A) major, block-bounding ('through-going') lineaments; (B) lineaments that have a similar orientation, intensity or style within a block but which may vary between blocks, and (C) smaller, local structural lineaments that may show only limited systematic relationships with the other lineaments in the same block. Lineaments of type A were identified first, then those of type B, then type C (Figure 15).

Both interpretations of valley lineaments found a mean orientation for the whole population close to N040° ± about 5°, reflected in a NE-SW peak in the data distribution (Figure 16A; 17A), but the second interpretation reveals a subsidiary group of valleys oriented NNW–SSE. These two orientations are emphasized when only the major lineaments are considered (Figure 17B) and is also reflected by the secondary lineaments (Figure 17C and 17D). The direction of the sparse local lineaments (Type C) was not analysed.

Both interpretations also recognise a fundamental subdivision of the area along the line of the secondary escarpment, offset by a NE-SW lineament aligned with the lower Nailbourne valley. The structural identity of Domain 2, and the presence of a bounding structure along the Barham Downs, is thus supported by the 'topographic' interpretation (Figure 15).

To the south of the secondary escarpment, a bounding lineament along the Lydden valley is also recognised in both interpretations. In the 'topographic' interpretation, however, no major lineament is noted between Domain 1 and Domain 3a. Moreover, Domain 3a is subdivided by a NNE-SSW lineament which appears to pass across the secondary escarpment into Domain 3b. This lineament is approximately aligned with inferred lines of faulting between Lyminge and Barham, suggesting that these might extend further to the north-east towards Adisham, intersecting with NNW-SSE faulting through Denton.

The ground to the north of the secondary escarpment (Domains 3b and 5 of the 'geological' interpretation) is divided into three by two further NE-SW lineaments. The more easterly (within Domain 5) is co-linear with an inferred fault zone between Temple Ewell and Ripple. The more westerly (within Domain 3b) is aligned with a fault zone at Chillenden, suggesting that this might extend further to the south-west towards Woolage Green.

7.4.8 Faulting in the Alkham valley

The geology of the Alkham valley, particularly in the vicinity of Alkham village and the Drellingore pumping station, has been the subject of some scrutiny and (as it now emerges) of some significant misinterpretations. The evidence merits examination in some detail.

The particular interest in this area arises from the presence of bourne springs and swallow holes at several places in the axis of the valley, and of a series of water boreholes between Lower Standen Farm and South Alkham. The hydrogeology of the valley is thought to be influenced by a series of NW-SE-trending fractures, which appear to provide hydraulic connectivity between the Alkham valley and coastal springs such as that at Lydden Spout (Reynolds, 1970; Cross et al., 1995). These phenomena have attracted the attention of several observers, some details of whose descriptions are at variance the published geological map.

Lucas (1908, p. 461) (quoted by Smart et al. 1966, p. 133) having described the Melbourn Rock in its occurrences at the coast, states that 'a buff-coloured rock, closely resembling the smooth parts of the Melbourn rock [i.e. the Melbourn Rock, *s.s.*], runs down both sides of the Alkham Valley as far as the vicarage [2574 4230], where it passes beneath the bed [valley bottom]. He continues: 'the first Folkestone well, sunk in 1898 at Lower Standen [TR24SW4; 241 404], went 70 feet [21.3 m] to a rock [bed], through which it passed for 20 feet [6.1 m]. A sample from the bottom [depth of 27.4 m] was like Melbourn. This well started some 7 feet [2.1 m] below the buff rock, which is therefore 97 feet [29.5 m] above the base of the Melbourn.'

However, subsequent work (Smart et al., 1966), confirmed by fieldwork during this project, has shown that the Melbourn Rock crops out low in the valley side at Lower Standen, its base lying at about 80 m OD close to the borehole. Thus the Lower Standen well is entirely in the Grey Chalk and by inference, the bed 'like Melbourn' at 27.4 m is part of the Zig Zag Chalk, parts of which are relatively massive.

This appears to substantiate Lucas's possible observation of the Melbourn Rock at Alkham vicarage, but the published geological map shows instead that it should pass underground just to the south-west of the village. However, field observation during this project found that topographic features and small exposures at Alkham are consistent with the occurrence of the Holywell Chalk cropping out in the village, and forming the bluff on which the vicarage stands. This implies the presence of a fault of considerable south-westerly downthrow in the ground between Alkham and Drellingore. Reynolds (1955, p. 446) inferred the presence of a NW-SE fault near South Alkham but, while this might well exist, the disposition of local topographic features suggests that a fault of greater displacement occurs close to Alkham village.

Recent observations also show that in the hillside to the south-east of Alkham village, the base of the Upper Chalk was placed significantly too low during the geological survey (Section 6.2.6). A small chalk pit beside a track at about 120 m OD some 720 m south-east of Alkham Church [2611 4192] exposes New Pit Chalk. It appears likely that to the south-east of the village, the

positive topographic feature forming the edge of the planar interfluvial area has been mistaken for a feature marking the base of the Upper Chalk, and so the published map is here significantly in error. However, chalk of the *plana* Zone has been recorded from a pit at about 95 m OD, 900 m east of the Church [2644 4223]. Thus the presence of another NW-SE fault can be inferred to the north-east of Alkham village.

Conversely, on the hillside north of the vicarage the base of the Upper Chalk appears to have been mapped reasonably accurately, a positive feature apparently marking the base of the Lewes Chalk occurring at about 85 m OD. This field evidence implies that an ENE-WSW trending fault, subparallel to the axis of the valley, passes immediately north of the vicarage.

Records for the Folkestone No. 3 well [TR24SW5], which is only some 350 m to the north of Standen Cottages, show that there the base of the Melbourn Rock occurs at about 40 m OD. These records include a stratigraphic interpretation by S C A Holmes (dated 25 October 1943) of specimens taken from known depths in the well. This evidence strongly implies that a fault of at least 30 m north-easterly downthrow crosses the valley in the ground between the Lower Standen well and the No. 3 well.

However, re-examination for this project of the specimens from this well (held in the BGS collections) found a single bivalve fossil of the species *Inoceramus pictus*, not of the genus *Mytiloides*, indicating a level in the Zig Zag Chalk at or above Jukes-Browne Bed 7, rather than within the Holywell Chalk. The rock types represented by these specimens are typical of the grey chalks and limestones of the lower part of the Zig Zag Chalk. One is of a particularly hard, dense limestone, which has apparently been mistaken as a piece of the Melbourn Rock. Landform mapping nearby suggests that the base of the Holywell Chalk occurs close to the surface at the No. 3 well, close to about 75 m OD. The rest of the well is in the Zig Zag Chalk. Some evidence for the inferred fault between Lower Standen and the No. 3 well can be found in nearby discontinuities and displacements of the negative topographic feature marking the base of the New Pit Chalk, but the downthrow is likely to be less than about 10 m.

The record for the Drellingore well [TR24SW10] shows that the base of the Melbourn Rock occurs at a similar level as was reported for the No.3 well, about 38 m OD. This would imply that another fault of considerable downthrow occurs between these two wells.

However, a recently excavated section behind the cottage on the north side of the lane, some 50 m west of the road junction at Drellingore [2409 4116] exposes about 2 m of shelly, nodular chalk, typical of the Holywell Chalk. This exposure is at about 80 m OD and is consistent with other field evidence which places the base of the New Pit Chalk nearby at 90 to 95 m OD. Field evidence also suggests that the Holywell Chalk is only some 20 to 25 m in thickness at Lower Standen, where both the base and the top crop out: so the base of the Holywell Chalk would be expected to occur at about 70 m OD at Drellingore. The Drellingore pumping station stands on a prominent terrace on the valley side, a landform typical of the Holywell Chalk, and similar to that at Alkham vicarage.

No samples are available for the Drellingore well, but on balance, it seems most likely that the stratigraphic interpretation of this well record is also incorrect, as has found to be the case for the Lower Standen and the No. 3 boreholes. This would appear to remove the principle evidence for faulting close to the Drellingore well.

However, Reynolds (1948, p.108, quoted by Smart et al., 1966) recorded the presence of faults intersected by adits driven from the Lower Standen, Folkestone No.3 and Drellingore boreholes. Typically these faults were oriented N130°, with some at nearly N180°. He notes (p. 107-108) that the south-western adit of the Drellingore well passed through two pear-shaped caverns, with their axes slanting upwards at about 40°, about 2.4 m in diameter and 4.6 m long. The largest fissure is below Drellingore Pit (a swallow hole/spring in the valley floor some 150 m SSW of the Drellingore well. Reynolds (1948, p. 84 - 85) infers the existence of a fault forming a 'comparatively impervious bar' across the valley some 140 m south-west of the Drellingore well,

with others between springs at South Alkham and at Drellingore, and between the South Alkham spring and nearby wells. Nearby field evidence suggests this fault is downthrown to the north-east.

Reynolds (1955, fig. 39) shows the position of several other NW-SE-trending faults crossing the Alkham valley, each controlling the position of a thalweg spring. A fault at Lower Standen crossroads is substantiated by a south-westwards downthrow of the base of the Holywell Chalk by a few metres. Localised subsidence occurred in 1946 on or close to the line of this fault, 300 m from the valley bottom, and also close to the site of the South Alkham spring in 1934 (Reynolds, 1970, p. 476).

Thus there is evidence for numerous NW-SE lines of faulting in the Alkham valley, even without considering the records for the three boreholes. Moreover, the apparent misinterpretation of the position of the base of the Upper Chalk could well have been repeated elsewhere in East Kent (Section 6.2.6) (although none came to light during the present project). It can be concluded that the details of the local geological structure could be significantly more complicated than shown on the newly revised geological map, at least in some areas. The resolution of such details, insofar as is possible, would require weeks of systematic field survey, and it is possible that such work would not add significantly to the general understanding of the local structure.

8 Some hydrogeological characteristics of the Chalk

8.1 INTRODUCTION

The Chalk is the major aquifer in the region. It receives most of the recharge in the project area. Groundwater in the Chalk emerges at springs, at least some of which are structurally controlled. The River Great Stour flows perennially across the Chalk outcrop, but several valleys within the Chalk carry seasonal or ephemeral 'bourne' streams.

The hydrogeological characteristics of the Chalk aquifer are thought to be influenced by several aspects of rock mass character, such as hardness (itself a function of chalk density), porosity and fracture style, which are to a large extent functions of the lithological assemblage found in each Chalk formation (Mortimore et al., 1990; Mortimore, 1993). In turn, the fracture style is thought to influence the fracture/fissure volume, and so also the hydraulic conductivity.

For example, the New Pit Chalk Formation, composed of fairly uniform, medium-hard chalks with sporadic marl seams, typically develops a network of steeply inclined conjugate joints. The joints serve to concentrate groundwater movement through the relatively brittle rock mass, until it meets a marl seam which has deformed plastically. Such marl seams tend to act as loci for bedding-parallel groundwater movement and solution-widened cavities commonly develop along them (Mortimore, 1993). Cross et al. (1995) note that permeability has developed above the persistent marl bands in the 'Middle Chalk' (New Pit Chalk and Holywell Chalk) of East Kent, leading to the occurrence of springs. They report a particular concentration of inflow above the Plenus Marls. In the Lewes Chalk, by contrast, the harder nature of the nodular chalk gives rise to more open joints. These are prone to dissolutional widening and may form significant conduits for groundwater flow. The Cast Bed (at the base of the Zig Zag Chalk) forms a spring line at Lydden Spout and is considered to be the limit of effective permeability in the Chalk in the Dour catchment (Acer Consultants Ltd, 1991).

The presence of other individual beds of relatively impermeable material, such as flint bands (especially tabular flints), hardgrounds and sponge beds, is also likely to be hydrogeologically significant. Major flint bands such as the Seven Sisters Flint and 'Whitaker's Three-Inch' in the Seaford Chalk can be expected to impede downward flow within the vadose zone and so become

significant groundwater flow horizons. Consequently, cavities can occur perched along flints or hardgrounds within the Lewes Nodular and Seaford Chalk formations (see cover picture).

The particular horizons followed by groundwater flow can be expected to vary laterally, depending on several factors such as whether a horizon is laterally extensive, its orientation relative to the hydraulic gradient, and whether it is intersected by fractures themselves acting as conduits. Solution cavities may be oriented either parallel to dip, or oblique or perpendicular to it depending on the direction of the maximum hydraulic gradient. Most karstic solution occurs close to the water table, so the extent of karstic development will also depend on its present and past position and the amount by which it has fluctuated.

Fracture zones are likely to create significant anisotropy within the aquifer. Some fault planes in the Chalk are marked by open fissures, whereas others are lined by chalk and flint breccia, and 'puggy' chalk. The occurrence of brown-coloured sandy clay within some fracture zones (see cover picture) indicates that they once acted as groundwater channels, whereas the broken and weathered materials lining the faults would presumably have strongly inhibited movement of groundwater across the fracture zone.

Some indication of probable variation in the effects of interaction between stratigraphy and structure in the Chalk is given by Cross et al. (1995) in a review of an eastern part of the project area. They state that the Dour Valley catchment is characterised by low summer flows, and falling productivity with falling groundwater levels, associated with reduced transmissivities. High winter flows are restored once the aquifer has recovered.

Flow is thought to occur on solution channels along bedding planes and fissures, such as have been discovered during the construction of water-well adits. Recharge is concentrated at swallow holes, where these such channels meet the surface. Artificial recharge in the upper Dour valley failed when the water returned to the ground within 50 m. Water is lost at the cliff line between Folkestone and Dover.

Conversely, to the west in the Rakeshole Valley and Upper Nailbourne, yield can be maintained even though groundwater levels fall. They also note that the groundwater head can be as much as 40 m different between a valley and the adjacent interfluvium in this area: permeable chalk is much thicker and extends to much greater depths beneath valleys. Hence recharge moves rapidly from interfluvium to valley. This also suggests that in this area the interfluviums act as barriers to groundwater flow between adjacent valleys.

Boreholes in the third hydrogeological area identified by Cross et al. (1995), the Dover-Deal Group, are reported to show relatively variation in groundwater levels and in yields. The aquifer seems to be characterised by slow flow through low permeability zones.

8.2 INTERPRETATION OF WATER FLOW HORIZONS AT DEPTH FROM GEOPHYSICAL LOGGING

8.2.1 Geophysical log measurements

In the Chalk geophysical logs have been traditionally used to recognise the Chalk Rock horizon at the base of the Upper Chalk, the Melbourn Rock and Plenus Marl horizons at the base of the Middle Chalk and top of the Lower Chalk and thus provide the traditional tripartite subdivision into Upper, Middle and Lower units. However the information provided by geophysical logs is such that it can also be used to identify the new more detailed Chalk stratigraphy as well as some individual named horizons (Section 6.3). This more detailed application can be used to relate known horizons of water flow to the lithology and stratigraphic sequence and provide a better understanding of the Chalk aquifer.

The interpretation of the new Chalk stratigraphy relies mainly on the characteristic responses and profiles shown by electrical resistivity logs recorded using 16/64-inch normal, focused resistivity

and single point resistance probes, and induction resistivity probes. These measurements are, with exception of induction resistivity, only possible below fluid level and within unlined (uncased) sections of the boreholes. The induction resistivity measurement can be made above and below fluid level and also within intervals lined with plastic, but not steel casing. For several boreholes penetrating the Chalk in the southern part of the Project area, which have static water levels deeper than 70 m and which are unlined, induction logging would provide useful stratigraphic information.

Examination of the resistivity and induction log profiles and recognition of the vertical sequence is the basis for the stratigraphic subdivision, backed up by macro- and micro-fossil evidence where available. Figure 18 shows typical 16- and 64-inch normal resistivity profiles recorded against the Seaford, Lewes Nodular, New Pit and Holywell Nodular Chalk formations penetrated in Boughton ABH1, together with some named horizons recognised from the profile, and interpreted water inflow horizons identified from the fluid log measurements recorded in the borehole. The resistivity profile illustrated for Boughton ABH1 is representative and consistent throughout the Project area and permits correlation of the Chalk strata from borehole to borehole at a level of detail which is not possible using the borehole drilling records.

The resistivity measurements respond to the chalk matrix properties and the presence of flint bands (high resistivity) and marl seams (low resistivity) in a diagnostic fashion but are also influenced by conductive (brackish or saline) pore fluids, and fissure and fracture groundwaters. The measurements made in Boughton ABH1 were recorded in 1977 shortly after acidization and they reveal an acid residual present in the borehole below 118 m which has affected the 16-inch normal resistivity curve. Several coastal boreholes of the Project area show elevated groundwater salinity at certain depths due to saline intrusion from the coast. This lowers the electrical resistivity and modifies the resistivity profiles. Some low-lying and inland boreholes also contain brackish or saline waters from prior seawater inundation, or from contamination by acid mine drainage waters from coal mining over a long period of time (Headworth et al., 1980). Lower resistivity due to increased clay content is also a characteristic of the Zig Zag and West Melbury Marly Chalk formations, but can be distinguished from the effects of saline groundwater by the accompanying increased response of the gamma ray log.

The gamma ray log complements the resistivity measurement and can be recorded in virtually any borehole whether fluid-filled, empty (dry), steel cased or open hole. It is thus not restricted in application. It is available for virtually all the boreholes that have been geophysically logged within the Project area.

For purposes of identification of the Chalk lithology and for correlation purposes the gamma ray log can generally identify only two and sometimes three distinct marker horizons, namely, the Glauconitic Marl at the base of the Chalk, the Plenus Marls (formerly marking the base of the Middle Chalk) and, where present, the hardground horizons near the base of the Lewes Chalk known as the Chalk Rock. In the Project area Chalk Rock *sensu stricto* is not present but is replaced by an expanded sequence of nodular chalk containing distinct marl bands (Bridgewick, Caburn, Southerham Marls) near the base of the Lewes Nodular Chalk. Fortunately this sequence has distinct resistivity and gamma ray profiles and can be identified by the geophysical logs. The gamma ray activity of the Chalk is very low (<10 API) and on its own the gamma ray log is not usually diagnostic of the stratigraphy unless it shows one or more of the marker horizons noted above. However where gamma ray logs have been recorded with sensitive detectors within an area, it is possible to match individual gamma ray features, and to correlate the vertical sequences (Figure 19). The maximum distance between the boreholes matched by gamma logs shown in Figure 19 is 5 km.

There are few distinctive geophysical log marker horizons within the Margate Chalk and Seaford Chalk Formations and the resistivity log matching relies on recognising the distinct profiles within the underlying Lewes Nodular, New Pit and Holywell Nodular Chalk Formations. The marked change from high resistivity and low gamma ray of the Melbourn Rock, to the low

resistivity and high gamma ray peak of the underlying Plenus Marls, at the base of the Holywell Nodular Chalk, represents the most distinctive geophysical log marker present in the Chalk. Below the Plenus Marls the gamma ray activity increases downwards through the Zig Zag Chalk and there is usually a stepped increase in activity against the West Melbury Marly Chalk which allows these units to be distinguished. The caliper log can sometimes be used to back up the stratigraphic interpretation. The Lewes Nodular Chalk and the Holywell Nodular Chalk are harder chalks and thus tend to stay closer to gauge (drilled diameter) whereas the softer New Pit Chalk sandwiched between tends to be soft, particularly its upper part, and thus shows on caliper logs as a generally larger diameter.

Table 5 summarises some statistics for the gamma ray (API) and resistivity (ohm.m) log measurements of the different Chalk formations present in the Project area. It is clear the gamma ray activity is not diagnostic although the West Melbury Marly Chalk has the highest gamma ray activity and the Holywell Nodular Chalk Formation has the lowest. The harder nodular chalk formations (Lewes, Holywell) have higher mean resistivity values as can be expected.

Other log measurements including bulk density, neutron porosity and sonic velocity are available for only a few boreholes, recorded mainly for coal exploration boreholes and which remain confidential. These measurements are not particularly useful additions to the resistivity-gamma ray combination and are too few to be used for correlation purposes.

8.2.2 Sources of geophysical logging data used

Some of the geophysical logging measurements in the Project area were recorded for coal exploration and geotechnical purposes (Channel Tunnel etc.) but most were recorded for the water industry or other hydrogeological investigations (Section 2.4). Southern Water, Mid-Kent Water and Folkestone and Dover Water Company commission geophysical logging of their drilled boreholes for their groundwater schemes, for public supply boreholes and for specific site investigations purposes. A number of boreholes were drilled and logged to monitor saline intrusion in the Dover-Deal area, eight boreholes were drilled and logged to investigate mine drainage contamination of the Chalk aquifer around the former Tilmanstone and Snowdown collieries. Several boreholes have been drilled on the Isle of Thanet to monitor nitrate inputs to the groundwater body. More recently BGS has drilled boreholes at Lower Venson Farm to examine the properties of the Chalk aquifer as part of the European FRACFLOW Project (Bloomfield, 1999, 2000) and has undertaken geophysical logging and hydro-geochemical sampling on behalf of Mid-Kent Water at a number of sites.

The BGS does not formally receive geophysical log data recorded in boreholes drilled, although it does hold many such logs. Geophysical logging data for the Project area was therefore collated from various sources. BGS held digital log data of 30 boreholes including logs of 9 coal exploration boreholes, and paper format logs for 114 boreholes. In addition Southern Water provided paper logs of 82 boreholes (some also held by BGS). Mid-Kent Water supplied paper logs for 19 boreholes, and the digital format original data for some of these records were subsequently made available to BGS by European Geophysical Services Limited (EGS). Veolia Water and Southern Water supplied digital log data for 8 boreholes around Folkestone and Dover.

The attention of the reader is drawn to the confidentiality clause on the cover of this report:

“This report contains commercially sensitive data from Folkestone and Dover Water Services, Mid Kent Water and Southern Water. Any person or organization who has a copy of this report should not make it available to others without written permission from Folkestone and Dover Water Services, Mid Kent Water, Southern Water and the Environment Agency.”

Geophysical logs of approximately 113 boreholes proved useful for interpreting the new Chalk stratigraphy and logs of 36 boreholes provided information on both the new stratigraphy and water flow horizons at depth. Colour composite plots of the logs recorded for each borehole,

prepared to a common format and showing the interpreted new stratigraphy and water inflow horizons are presented in an Appendix. Although widely-spaced within the Project area, this subset of boreholes forms the basis of the interpretation of water inflows at depth. It is constrained by the available logging data and the resources available to interpret it.

8.2.3 Identification of groundwater flow horizons at depth

Some information on water inflows at depth in the Chalk aquifer is provided by the water strikes shown on drillers' records but more precise and reliable identification of groundwater flow at depth in the Chalk is provided by fluid logging in the boreholes after drilling. Waters recharging from the surface circulate within the Chalk to catchment outlets via specific circulation routes, and the water entering boreholes from these different circulations display small differences in fluid temperature and fluid electrical conductivity (EC) depending upon their circulation history and residence times. These differences can be recognised by the fluid log measurements, and in the Chalk are often seen as stepped changes on the fluid log profiles (see Figures 20–24) often coincident with caliper log evidence of hole diameter enlargement, usually signifying fissure enlargement by groundwater flow.

Boreholes penetrating the Chalk generally interconnect several water flow horizons and their normal open hole construction permits circulation of groundwater between the various layers penetrated. Fluid logging in Chalk boreholes commonly identifies vertical flow of water between particular horizons (well bore flow), up or down the borehole, depending upon the relative hydraulic heads of the layers. It can be recognised on log profiles as intervals where there is little or no vertical temperature or EC gradient usually linking horizons showing caliper enlargement. Figure 20 is an example from Dover-Deal borehole C6 of down flow of relatively cool water, from a fissured horizon in the Seaford Chalk at 32 m depth to a fissured horizon in the Lewes Nodular Chalk at 72 m depth. Similarly the relatively warm water and vertical temperature profile shown between -94 m OD and the screen section 40-50 m above it in West Stourmouth obh2 (Figure 21) indicates upward well bore flow from a fissured horizon developed high in the Lewes Chalk to its exit into the screened interval. In both cases the well bore flow may be driven by natural head difference or by local pumping, or a combination of both. In the former example the inferred down flow of cool groundwater is taking place in a recharge area, and the upward flow at West Stourmouth is within a groundwater discharge area.

Within those boreholes close to the coast containing brackish or saline water, inflow horizons can be identified by observing the fluid EC and fluid temperature changes taking place at depth in response to the groundwater and sea tide. Figure 22 illustrates such changes monitored by the SWA in Dover-Deal borehole C3 in 1981 and 1982. It is evident from the 1982 measurements that at low sea and groundwater tide the borehole fluid is both fresher and cooler from water table to c.170 m depth, whilst at high tide high EC water (c.18 000 uS/cm) enters at 96 m (-10 m OD), 148 m (-62 m OD) and at 156 m depth (-70 m OD) to occupy the borehole. Below -85 m OD the fluid EC becomes relatively constant and there is an increased temperature gradient signifying little or no fluid inflow and only density settling of the fluid to the bottom of the borehole. At low sea tide the freshwater head drives out the brackish fluid above -85 m OD, but not below because there is no outflow taking place to remove it. The location of the stepped changes indicate the flow horizons. The 1981 logging also identified cooler lower EC water movement at 101 and 106 m depth. It can be noted that the stepped horizons all correspond to caliper enlargements indicative of fissures. The effect of the brackish water on the normal resistivity measurements is evident between 150-175 m depth and it is evident that resistivity logs recorded in borehole C3 will be time variant depending upon the state of the tide.

Fluid log profiles are transient. They are shaped by the prevailing hydraulics and respond to local and more distant abstraction. These 'induced' profiles are not always easy to interpret correctly and comparison with measurements made at different times under changed hydraulic conditions may be necessary to identify the inflow horizons correctly.

The best evidence of groundwater flow at depth is provided by recording the fluid EC, TEMP and flowmeter measurements prior to and whilst pumping the borehole (ECQ, TEMPQW, FLOWQ) and comparing the profiles. When pumping the water movement is generally (though not always) towards the borehole and comparison of the pre-pumping profile with the pumping profile pin-points the water inflows from the changes that take place when the borehole is stressed. The borehole flowmeter measures the vertical velocity, and volumetric flow rate to the pump and confirms the inflows and their relative contribution to the total yield. Of the 36 boreholes that have been selected only 6 have fluid logs that were recorded whilst pumping, of which only 4 have flowmeter measurements made whilst pumping.

Figure 23 illustrates pumped fluid EC, fluid temperature and borehole flowmeter profiles recorded by BGS in Reculver borehole1 during surveys for Mid-Kent Water in 1991-1993. The borehole was drilled on the edge of the Thames Estuary in 1991 to test the feasibility of a reverse osmosis scheme for brackish groundwater abstraction. It entered the Chalk beneath 32 m of Palaeogene strata and penetrated the Plenus Marls at 200 m depth. It was acidized after drilling and the effect of acidization is shown by the yellow infill between the pre- and post-acidization caliper logs. After drilling brackish groundwater entered the borehole at shallow level and occupied the borehole. The 16-inch normal resistivity log (Stows 16R) and fluid EC (EC2 Stows) document the high fluid salinity below 50 m depth.

The borehole was fluid logged whilst test pumping and the fluid TEMPQ and ECQ profiles developed a series of steps alongside inflows where cooler and better quality water was entering and modifying the upward flowing mixture. Impeller flowmeter measurements, corrected for borehole area (ac-flowmeter) shown in the right hand column identified the inflow quantities and their relative contributions to the total pumped. In this case 12.5% was obtained from the Lewes Chalk at 104 m depth, 35% from the Seaford Chalk at the three inflows shown, and the largest inflow, approximately 50%, was from the Margate (Newhaven) Chalk, just below the casing. The same inflows were identified in the Reculver 2 borehole 750 m away. It is evident that pumping 'sharpens up' the fluid log profiles and the inflows can be identified more easily and more reliably

The fluid inflows interpreted from the fluid logging data for the boreholes in the Project area are shown on the composite plots in the data Appendix as horizontal blue lines drawn at their positions. Where the inflows are uncertain the lines are shown dashed. The interpretations of flow horizons based on pumped fluid logging measurements are more reliable than those based on the induced profiles.

A summary of the inflow horizons interpreted from the logging data analysed within the Project area is presented in Table 6.

8.2.4 Conceptual model of groundwater movement in the Chalk aquifer from geophysical logging observations

Geophysical logs reveal that water inflows in Chalk boreholes are concentrated at certain specific horizons at shallow depth below the water table. Usually there are only a few main inflows and the bulk of the section is not contributing except through drainage towards the main inflows. The inflows are often associated with particular flint, marl and hardground surfaces, and the new more detailed Chalk stratigraphy allows us to put names to the associated horizons. Logging also shows that flow horizons identified at shallow depth in upstream portions of catchments are not generally present at those same stratigraphic horizons when located at greater depth further down the catchment. This is because their development is also hydraulically controlled by the groundwater circulation that takes place to shallow discharge points, usually the shallowest outlet to the surface water drainage system. The development of permeability in the Chalk therefore tends to be restricted to a shallow zone close to the water table. This tends to cut across the strata because of the hydraulic control, and also because the Chalk is soluble and recharge inputs have least calcite-saturation at shallow depth. Logging and other observations

show that this zone of groundwater movement is generally within 50 m of the current water table and that the most rapid circulation usually takes place within the top 25 m of the saturated zone.

The dip of the Chalk is usually between 5 and 15 m/km. The water table slope is normally much shallower. Because the shallow flow horizons identified in upstream parts of the catchment do not extend beyond a certain depth, the groundwater flow must 'step up' the Chalk sequence via available joint, fracture and fault systems, moving to occupy suitable horizons closer to the surface. In time such flow routes become well-developed fissure pathways. The inflows identified in the boreholes are thus part of a current groundwater flow system that is developing the aquifer permeability through specific circulation pathways to the nearest discharge outlets. This is why it is usually observed that the best yields are obtained within the top 50 m of the Chalk and also why the prospects of high yields at depth from the Chalk are poor.

The flow horizons do not develop at random within the sequence but become focused along surfaces of lower porosity chalk, flint horizons or significant marl seams. They are also found where there are changes in lithology or bed thickness which alter the style or frequency of fracturing. It can be expected that river flow accretion will reflect the delivery of groundwater where the rivers and streams intersect horizons that are the preferred groundwater flow routes.

The hydraulic base level controlling the flow system circulation has not always been the current sea level. Groundwater circulation has taken place within the Chalk from the moment of emergence at higher sea levels during wet periods of the Palaeogene, and to both higher and lower base levels than present during the Pleistocene climate changes. Evidence for circulation to different base levels is shown by caliper logs which identify fissuring at high levels well above current water table (sometimes responsible for groundwater flooding in certain areas) and fissured horizons well below current sea level. In the Reculver example the flowmeter revealed 70% of the discharge of the borehole was obtained from above -53m OD. The morphology and depth of buried channels immediately offshore, reported by Bridgland and d'Olier (1995), strongly suggests a link between the developed permeability of this upper zone and a former outlet base level of -50 to -60 m OD (Buckley et al., 1996).

Fluid temperature log profiles in the Chalk boreholes show generally cooler water and shallow temperature gradients to a certain depth consistent with the zone of more rapid groundwater movement. Below this depth the temperature gradient increases sharply indicating relatively little or no groundwater movement. The base of this zone of more rapid groundwater can be quite sharp on the temperature logs. Table 7 shows the estimated depth to the base of the faster zone where it has been possible to identify it. The indicated mean depth is 66.9 m below water table, (-56.5 m OD). A more detailed analysis of the flow horizons present would require pumped fluid and flowmeter measurements, borehole dilution tests or packer testing to be undertaken.

Figure 24 compares borehole flowmeter measurements and packer test data for the Lewes Chalk and the greater part of the Seaford Chalk as recorded in the BGS Totford borehole in Hampshire. The same stratigraphic interval was penetrated in the Boughton ABH1 (note similar resistivity profile, in Figure 18) and Reculver 1 boreholes, amongst others, but there is no equivalent dataset for East Kent. It shows that the cumulative flow rate profile and its interpreted inflow histogram, shown in green, agree well with the packer test measurement of hydraulic conductivity (shown in red) in the borehole. The flowmeter resolved important inflow through the wellscreen slots near the top of the borehole which was not packer tested. The packer testing identified a zone of higher permeability within the Lewes Marl - Southerham Marl interval not seen by the flowmeter because the flowmeter measurement is head-dependent. The fluid temperature and EC log measurements recorded whilst pumping nevertheless identified movement along this deep horizon. The matrix hydraulic conductivity measurements made on the cores, shown in black, underline the importance of the secondary solution fissures for groundwater flow in the Chalk. The flowmeter measurements in this example again reveal that

the overwhelming bulk of the groundwater is obtained from within 25 m of the watertable when the borehole is pumped.

8.2.5 Hydrogeological cross-sections

The geophysical log data has been used to compile three hydrogeological cross-sections within the Project area (Figures 25 - 27) to illustrate the new Chalk stratigraphy, the geological structure and their relationship to the water inflows.

Figure 25 shows a SW-NE scale section from Stonehall ABH (NGR 626939 145673) to Sandwich Bay. The general north-easterly dip of the Chalk is 8.5 m/km and the maximum watertable slope is 3.6 m/km. Overlying Palaeogene and Margate Chalk strata are not identified in the borehole logs and are not shown. The ground surface depicted is schematic.

The section crosses and re-crosses an important fault running north-east and then north-north-east from Densole [TR 22 42] to Worth [TR 32 55] (see 1:50 000 map) and is shown by the dashed vertical lines. Water inflows identified by the logging are depicted on the sections as horizontal blue lines. The watertable (SWL) occurs within the Lewes Nodular Chalk in Stonehall ABH in the south-west but because of the steeper strata dip is within the Seaford Chalk some 1500 m down section and remains within Seaford Chalk to the coastline. At Stonehall ABH one inflow is present near the base of the Lewes Nodular Chalk and two inflows are present from the New Pit Chalk close to the watertable. At the Venson Farm site three inflows in the Seaford Chalk are within 20 m of the watertable, and there are also three inflows within the bottom half of the Lewes Chalk. (The inflows shown for borehole 2 are actually those recorded in adjacent borehole LVF-V when it was pumping). The fluid EC log for Venson Farm borehole 2 shows elevated salinity at depth below a fissured horizon at 105 m. The fluid temperature log suggests this water is not moving or only slowly moving. It is known to be re-circulated mine drainage water formerly discharged from the nearby Tilmanstone Colliery upgradient of the site. The fault shown on the 1:50 000 geological map, noted above, is likely to have influenced the shape of the contamination plume.

The Old Downs Farm borehole logs were digitised from SWA paper log copies recorded in 1981. It is believed the borehole is a former NCB exploration borehole that was backfilled to 191 m depth and when logged was 139 m depth. Brackish water (~ 15 000 uS/cm) enters the borehole at 29 m depth and below about 90 m the fluid EC is relatively constant and approximately 50% seawater salinity. The brackish water could be from modern seawater intrusion, but it might be an older (Holocene or Pleistocene) saline groundwater, as is known from elsewhere in the Project area..

Figure 26 shows a scale cross-section south to north through three SWA saline monitoring boreholes near St. Margarets and Kingsdown. This was derived from paper geophysical logging data recorded in 1981-1986 and digitised by the BGS. The saline intrusion proceeds from the coastline to the east of the boreholes and normal to the plane of section. The section shows Seaford Chalk at the surface except for the hill top cappings of Margate Chalk as indicated. The watertable is relatively flat and only a few metres above mean sea level. It is mid-way down the Lewes Chalk in borehole C2, but because of the steeper strata dip is nearer to top of the Lewes Chalk in borehole C3 and is within the Seaford Chalk beyond 3 km down-section. The watertable is 45-80 m below surface in Borehole C2 and C3, and the caliper logs reveal significant fissuring up to 50 m above SWL in borehole C3. Several possible fluid inflows indicated in borehole C3 are based on evidence from saline intrusion monitoring. There is inflow from near the top of the Holywell Chalk in this borehole. Two water inflows from the Seaford Chalk are recognised in borehole C6 and saline water enters the borehole from a fissured zone at -48 m OD. Both borehole C3 and C6 are mostly occupied by brackish water.

Figure 27 presents a scale section from the Great Stour near Stodmarsh borehole generally north-east to the Thames Estuary at Reculver, approximately down flowline. The general north-

easterly strata dip is interrupted by the Thanet anticline which is shown close to Ford PS in the centre of the section. Palaeogene sediment cover is present in all the boreholes ranging in thickness from 8 m at Ford PS to 65 m at Hoath. Where the Palaeogene cover is present there can be solution and erosion leaving an irregular upper surface of the Chalk and it is commonly necessary to extend the casing some way into the Chalk to ensure stability and avoid sand pumping. A thin layer of Newhaven (Margate) Chalk is thought to be present at the top of Hoath and Reculver boreholes.

The borehole casing in Hoath borehole extends 10 m below the Palaeogene contact and might have lined-out shallow inflows from the Chalk. When pumped for fluid logging purposes it showed a low specific capacity (0.4 m³/h/m) and water inflows were not identified deeper than 35 m below the top of the Chalk. It seems likely in view of the brackish water present in the borehole and its low specific capacity that Hoath borehole is possibly within a zone of low permeability chalk, and that groundwater flow approaching from the south is probably diverting both east and west in front of the Thanet anticline, parallel to the fold axis.

The groundwater in the Ford PS well is both cooler and has low fluid EC, consistent with shallow recharge through the local Palaeogene sediments. The large diameter brick-lined well at the PS is reported to contain a bore extension in its base, as depicted by the dotted vertical line, but it was not possible to locate it with logging probes. North of the fold axis the water in the Reculver boreholes, sited on the edge of the Thames Estuary, represents shallow entry of brackish groundwater and density settling below. It is likely the fold axis upgradient of the boreholes restricts the throughflow potentially available. Smedley (1999) recognised three zones of different salinity groundwaters within the Reculver borehole and related them to prior seawater inundation and subsequent re-freshening throughflow. The interpreted water inflows in the two Reculver boreholes are at the same elevations. Their main inflows from the Chalk are at 7 m and 27 m below the Palaeogene contact (Reculver 1) and at 5 m and 25 m below the Palaeogene contact in Reculver 2 (-51 to -53 m OD). Their inflow data represent the best quality inflow information available for any of the boreholes. The deepest inflows confirmed by the few impeller flowmeter measurements made within the Project area are -100 m OD in Hoath obh, and -96 m OD in the Reculver boreholes.

8.3 BOURNE STREAMS, SPRINGS AND SINK HOLES

Springs occur widely within the Chalk of the project area. Some give rise to ephemeral surface water flow within bourne streams. Direct point recharge into swallow holes in the Chalk has been observed at widespread localities in the floors of valleys within the Chalk outcrop, and near the base of the Thanet Formation west of the Great Stour. Recharge from the Thanet Sand Formation into the Chalk is likely to occur along the 'feather edge' of the Palaeogene outcrop, especially where dissolution has enhanced the permeability of the Chalk. Some sites can act as either springs or swallow holes, at different times, depending on the state of the aquifer.

Information in this section is derived mainly from literature review. Some of the springs and swallow holes mentioned in the literature are shown on the geological map. Many springs are stratigraphically controlled (for example, the Cast Bed at the base of the Zig Zag Chalk can act as a spring line) but some appear to have a greater measure of structural control. It is likely that the occurrence of swallow holes is similarly influenced by both stratigraphy and structure. Interpretations are offered in the light of geological modelling and map compilation for this project.

8.3.1 The Nail Bourne (including the Barham Valley)

When groundwater levels are high, flow occurs in the Upper Nail Bourne, but tends to diminish and disappear downstream (Cross et al., 1995). The Upper Nailbourne is reported to rise, at its highest, at a spring at Etchinghill [1648 3948] (Whitaker, 1908). This is close to the mapped base

of the Zig Zag Chalk, the stream running northwards across the outcrop of the West Melbury Chalk, implying stratigraphic control.

In February 2004, the Nail Bourne had surface flow between Ottinge [170 422] and a pond at North Elham [1825 4465], being dry further downstream. This pond lies within the Holywell Chalk outcrop, close to a probable ESE-WNW trending fault line aligned with Drellingore and Lydden Spout.

Whitaker (1908, p.58) notes that the usual lower limit of flow during dry seasons is near Bourne House [183 533]. However, during February 2004, the Nail Bourne had surface flow from the artificial pond at this point downstream through Bridge to the artificial pond just south-west of Patribourne. Edmunds (quoted by Smart et al., 1966, p. 278) noted that during the summer of 1951 a stream flowed strongly in the valley bottom in Bourne Park for about 1.5 miles [2.4 km] between two dry stretches. This section of the valley floor apparently overlies the upper part of the Lewes Chalk and the lower Seaford Chalk, which could be expected to be less permeable than the lower part of the Lewes Chalk.

At times, water sinks at Barham [2048 4917], possibly controlled by an inferred NNE-SSW line of faulting which intersects the thalweg close to this point.

During the Autumn 2000 flooding events, the Nail Bourne flooded the villages of Patribourne, Littlebourne and Wickhambreaux (Environment Agency, 2001). In February 2004, this stream was dry between the weir on the south side of Patribourne [1890 5498], at least as far downstream as Bekesbourne [1948 5562]. Whitaker (1908, p.58) reports that in dry seasons water lost below Bridge rises again Bekesbourne and Littlebourne. The perennial Well Chapel spring [2010 5640] lies very close to a NNE-SSW line of faulting which crosses the Nail Bourne valley at an oblique angle downstream of Bekesbourne. The presence of this fault line was inferred from displacements in the mapped base of the Thanet Formation and of the Margate Chalk, without reference to the position of the spring. It seems very likely that the Well Chapel spring is structurally controlled, and that the same fault zone influences spring flow in the bed of the Nail Bourne below Bekesbourne.

8.3.2 Alkham Valley

In common with the other bourne streams in the area, ephemeral surface flow in the Alkham valley has been observed to rise preferentially at a number of discrete springs, rather than by continuous seepage throughout the thalweg.

The highest point recorded, during very wet periods, is at Lower Standen [2385 4025], with the Holywell Chalk. The base of the New Pit Chalk is displaced by a small WNW-ESE fault within 100 m of this point (Section 7.4.8).

About 900 m downstream, another arising occurs in a round depression, near Drellingore [2430 4105]. This lies on an inferred line of WNW-ESE faulting, which probably continues south-east towards Lydden Spout.

Lucas (1908, p. 467) notes that the bed of the Alkham Valley is dry above Chilton Spring [279 435], except when the Drellingore bourne is flowing. He states that there are also depressions in the bed of the valley at Chilton Farm [2763 4328], Wolverton [2668 4278], Church Alkham [256 422] and South Alkham [2500 4165]. The Wolverton depression can act as a sink for flow from Drellingore, this being the lowest of several such sinks in the valley. Reynolds (1948) confirms the existence of most of these sources, adding that springs sometimes arise at Lower Standen pumping station, and that the bourne sometimes disappears into its bed 'between Alkham and Wolverton'.

8.3.3 Petham Valley

An ephemeral stream in the Petham valley is reported to rise in a hollow in the eastern part of Petham village [1298 5147], forming a pond (Whitaker, 1908, p. 59). Although this pond lies in the thalweg of the main valley, it also marks the intersection with tributary valleys to the south-east and to the south-west, implying some element of structural control.

In wetter periods, the Petham valley stream has been recorded as rising at Duckpit Farm [123 501]. Recently constructed drainage ditches extend from about 200 m above to a point 250 m downstream of Duckpit Farm. According to the new mapping, Duckpit Farm lies low in the Lewes Chalk, suggesting the possibility of stratigraphic control by hardgrounds, flint bands or marl seams, but like the spring at Petham, it also lies at the mouth of a south-eastern tributary valley. The configuration of topographic features in the eastern valley side [127 501] suggest that minor faulting on a NW-SE trend occurs in the vicinity of Duckpit Farm. Similarly, a pond at Yockletts Farm [1214 4775] is aligned with an indentation in the valley-side to the SSE. The highest point in the Petham valley at which surface flow has been recorded is Dean Farm [124 465] (Whitaker, 1908, p. 59). This lies at a confluence of valleys, but also close to the mapped base of the New Pit Formation, suggesting an element of stratigraphic control by relatively impermeable chalk with marl seams.

This stream tends to sink either at Swarling Manor Farm [131 529], where the valley turns abruptly to the west, probably due to fault control, or in a pond at Perry Court Farm [111 535] (Whitaker, 1908, p. 60).

No surface flow near Petham was apparent during February 2004.

8.3.4 Other springs

Springs occur at numerous localities near the base of the primary escarpment. Some emerge at the base of the West Melbury Chalk (Smart et al., 1966), presumably where the Glauconitic Marl provides relatively enhanced permeability above the Gault, but some appear to be controlled by limestone beds within the West Melbury Chalk.

9 Conclusions

The geological map of the North Downs in East Kent has been revised to incorporate the new Chalk lithostratigraphy. The presence of the lowest seven new Chalk formations (listed below) can be recognised from existing geological descriptions of the area, and was confirmed by reconnaissance fieldwork. Their outcrop patterns were mapped using available published and unpublished evidence. The new linework should be regarded as an approximation which would be significantly improved by detailed field mapping.

The Chalk outcrop of East Kent is relatively complex, topographically. In the greater part of the area, the Chalk dips gently north-north-eastwards, forming the North Downs, being covered in the north by Palaeogene deposits. This main outcrop is bounded to the south-west by the North Downs escarpment, but is also divided in two by a weakly defined, subparallel, secondary escarpment. This bounds the north-eastern side of the Dour Valley at Dover, continuing north-westwards as far as the Barham Downs at Bridge. It is there offset to the south-west, continuing through the Chartham Downs to the River Great Stour. The secondary escarpment marks the south-western limit of the Margate Chalk and is structurally controlled, at least in part. The offset between the Barham Downs and the Chartham Downs is apparently structurally controlled by the Stour Valley Fault Zone.

The improved subdivision of the Chalk has been used in conjunction with borehole and seismic data to produce a three-dimensional geological model of the area.

Logs (both lithological and geophysical) from about 380 boreholes were found to provide useful information about at least one stratigraphic boundary in the Chalk. None of the boreholes had been previously interpreted using the new Chalk lithostratigraphy. Where borehole records note a depth for the base of the Middle Chalk, a standard factor of 2.5 m was added to derive a value for the depth of the base of the Holywell Chalk. Similarly, where borehole records note a depth for the base of the Upper Chalk, a standard factor of 16 m was added to derive a value for the depth of the base of the Lewes Chalk. Note that, at the coast, this is some 10 m higher in the sequence than if the base of the Lewes Chalk were placed at the base of the Akers Steps Member of Robinson (1986), as indicated by Mortimore et al. (2001).

Data from seismic surveys that occur entirely within the area has been processed and interpreted for the respective bases of the Upper Chalk, the Middle Chalk and the Lower Chalk. These seismic picks represent a reasonable approximation to the bases of the Lewes, Holywell and West Melbury Chalk formations.

Following extensive review of the borehole records, their correction where possible and rejection of those obviously in error, the dataset (of both outcrop and subsurface information) used for modelling is felt to be of reasonably high quality for a project of this kind. The best constrained surfaces are those marking the base of the West Melbury, Holywell and Lewes chalk formations and of the Palaeogene, although information for the chalk becomes generally sparser towards the north of the area. The least well constrained surfaces are those of the base of the Zig Zag Chalk, the New Pit Chalk, the Seaford Chalk and the Margate Chalk.

Information from geological mapping, from measured sections and from boreholes suggests that the following thicknesses can be taken as typical for the respective chalk formations in East Kent:

Margate Chalk	0-28 m; being extensively cut-out by the base of the Palaeogene
Seaford Chalk	Mostly between 45 and 61 m, typically 52 m
Lewes Chalk	Mostly between 50 and 61 m, typically 60 m
New Pit Chalk	Mostly between 33 and 40 m, typically 36 m
Holywell Chalk	Mostly between 12 and 20 m, typically 18 m
Zig Zag Chalk	Mostly between 35 and 46 m, typically 42 m
West Melbury Chalk	Mostly between 30 and 40 m, typically 34 m

The Palaeogene sequence comprises the Thanet Sand Formation, at the base, overlain in turn by the Upnor Formation, the Harwich Formation and the London Clay Formation.

The Chalk generally dips at 1° or less, with steeper dips occurring locally in the vicinity of faults and folds. The dip direction is typically to the north-north-east (N025°) but in the east, near the coast, the dip direction is commonly more towards the north-east (N040°). Conversely, in some areas in the west, it turns to a more northerly direction. Strike directions also turn to an east-west orientation near the edge of the Palaeogene outcrop between Wingham and Eastry, continuing northwards through the Richborough Syncline and the complementary Thanet Anticline into the Isle of Thanet. Several smaller WNW-ESE-trending folds occur close to the coast between Folkestone and Dover, including the Dover Anticline.

Faulting is considerably more extensive in East Kent than indicated by previous geological maps.

Three classes of fault are shown on the new geological map of East Kent which accompanies this report.

- Faults shown as full (unbroken) black lines are those inferred from outcrop information. Most were subsequently corroborated by modelling of subsurface information.

- Faults shown as pecked (broken) black lines are those inferred from subsurface information alone. Some might be confined to subsurface layers.
- Faults shown as magenta lines are classed as 'speculative'. Their existence is inferred from the general appearance of outcrop patterns, from the presence of topographic lineaments, or from offsets or changes in landscape 'texture', but without specific evidence for the displacement of geological boundaries.

In unexposed Chalk terrain, it is rarely possible to distinguish a broad, gentle anticlinal fold from a broad fault zone, with certainty. It is difficult to demonstrate unequivocally the existence of faults in unexposed Chalk by geological field survey unless the faults are relatively large. As with all geological maps, that which accompanies this report is an interpretation of information available at the time of compilation. It is felt to represent a reasonable position between 'cautious under-interpretation' and 'ambitious over-interpretation'. Other interpretations of the same information are possible, although it is thought likely that the differences compared with the present interpretation would be in matters of detail. Consideration of the significance of the detail of the present map should bear this in mind.

Other than in the Isle of Thanet, most fault orientations in East Kent can be treated in two broad groups: NE-SW (including a subset oriented NNE-SSW) and WNW-ESE. In addition, NNW-SSE faults occur locally, particularly in a zone to the west of Canterbury. A broadly similar fault pattern has been found by earlier workers in East Kent and in northern France, although N-S faults previously found at outcrop in Kent are not represented at the map scale.

Fault trends on the Isle of Thanet are less clearly defined, including E-W, NW-SE and N-S elements.

The newly recognised Stour Valley Fault Zone occupies a NE-SW-trending linear zone, between about 3 km and 5 km wide, along part of the Great Stour valley. It is complex zone resulting from the intersection of NE-SW and NNE-SSW faults, offset by a NNW-SSE fault zone through Chilham, and probably terminated by another at its northern end, near West Stourmouth.

The Stour Valley Fault Zone marks a considerable change in structural style between the Chalk of North Kent and the Chalk of East Kent. Major offsets in the outcrops of the Seaford Chalk and the Palaeogene occur across the zone. The secondary escarpment (and the outcrop of the Margate Chalk) are offset to a similar extent at the eastern side of the zone, and are cut out at its western side. The western extent of the Margate Chalk outcrop thus appears to be structurally controlled.

Slope aspect analysis was used as a guide to the distribution of linear valleys in the project area, as a proxy for fracture patterns and as a guide to the location of major structures. Differences in lineament orientation support the interpretation of:

- a NW-SE bounding structure at the southern foot of the Barham Downs, a presumed north-western continuation of the Dour Valley fault zone
- the presence of NE-SW faulting in the south-east of the Stour Valley Fault Zone
- a NE-SW bounding structure along the Lydden valley, along which relative rotation of adjacent domains has occurred
- inferred NE-SW fault zone between Temple Ewell and Ripple, and near Chillenden
- inferred NNE-SSW faults between Lyminge and Barham, suggesting that these might extend further to the north-east towards Adisham, intersecting with NNW-SSE faulting through Denton

Local field evidence substantiates previous suggestions that several significant NW-SE fault lines cross the Alkham valley, at least between Lower Standen and Alkham village. The published geological map is significantly in error in the vicinity of Alkham, and the likely origin of the error suggests that similar inaccuracies occur elsewhere in East Kent. The details of the

local geological structure could thus be significantly more complicated than shown on the newly revised geological map, at least in some areas. However, it is likely that the resolution of such details would not add significantly to the general understanding of the local structure.

The Chalk is the major aquifer in the region. The hydrogeological characteristics of the Chalk are thought to be influenced by aspects of rock mass character, such as hardness, porosity and fracture style, which are to a large extent functions of the lithological assemblage found in each Chalk formation.

The particular horizons followed by groundwater flow can be expected to vary laterally, depending on several factors such as whether a horizon is laterally extensive, its orientation relative to the hydraulic gradient, and whether it is intersected by fractures themselves acting as conduits. Solution cavities may be oriented either parallel to dip, or oblique or perpendicular to it depending on the direction of the maximum hydraulic gradient. Most karstic solution occurs close to the water table, so the extent of karstic development will also depend on its present and past position and the amount by which it has fluctuated.

Fracture zones are likely to create significant anisotropy within the aquifer. The occurrence of brown-coloured sandy clay within some fracture zones (see cover picture) indicates that they once acted as groundwater channels, whereas the broken and weathered materials lining the faults would presumably have strongly inhibited movement of groundwater across the fracture zone.

Geophysical logs of approximately 113 boreholes proved useful for interpreting the new Chalk stratigraphy and 36 logs of 34 boreholes provided information on both the new stratigraphy and water flow horizons at depth.

Geophysical logs reveal that water inflows in Chalk boreholes are concentrated at a few specific horizons at shallow depth below the water table. The inflows are often associated with particular flint, marl and hardground surfaces. Logging also shows that flow horizons identified at shallow depth in upstream portions of catchments are not generally present at those same stratigraphic horizons when located at greater depth further down the catchment. The development of permeability in the Chalk tends to be restricted to a shallow zone close to the water table. This tends to cut across the strata because of the hydraulic control, and also because the Chalk is soluble and recharge inputs have least calcite-saturation at shallow depth. Logging and other observations show that this zone of groundwater movement is generally within 50 m of the current water table and that the most rapid circulation usually takes place within the top 25 m of the saturated zone.

Water inflow horizons have been identified in all seven chalk formations, depending on the depth of the borehole and its position. For example, the Drellingore pumping station appears to be taking most of its water from the Zig Zag Chalk; Dover-Deal C3 has inflows from the Holywell, New Pit and Lewes chalks, and Dover-Deal C6 from the New Pit, Lewes and Seaford chalk formations. The Cast Bed, at the base of the Zig Zag Chalk, is believed to be the lower practical limit of the aquifer, although possible inflow from the West Melbury Chalk has been found in one borehole, and on the face of the North Downs escarpment springs emerge from low in the West Melbury Chalk.

Springs occur widely in the project area. In addition, bourne streams and swallow holes are a well-known feature of three of the largest valleys in the project area. Stratigraphic or structural controls, or both, can be inferred for many of the known springs and swallow holes. For example, the Well Chapel spring near Littlebourne, lies on a NNE-SSW fault zone where it crosses the Nailbourne valley, and which appears to have acted as an along-strike conduit and an across-strike barrier to groundwater flow.

10 References

Most of the references listed below are held in the Library of the British Geological Survey at Keyworth, Nottingham. Copies of the references may be purchased from the Library subject to the current copyright legislation.

- ACER CONSULTANTS LTD. 1991. Lydden Spout Final Report. *Unpublished report to Folkestone and District Water Company*.
- ALDISS, D T, and FARRANT, A R. 2002. An appraisal of the early Palaeogene deposits of North Kent. *British Geological Survey Commissioned Report*, CR/02/315.
- ALLEN, D J, BREWERTON, L J, COLEBY, L M, GIBBS, B R, LEWIS, M A, MACDONALD, A M, WAGSTAFF, S J, and WILLIAMS, A T. 1997. The physical properties of major aquifers in England and Wales. *British Geological Survey Technical Report*, WD/97/34. Environment Agency R&D Publication 8.
- AMEEN, M S. 1995. Fracture characterization in the Chalk and the evolution of the Thanet monocline, Kent, southern England. 149-174 in *Fractography: fracture topography as a tool in fracture mechanics and stress analysis*. *Geological Society of London Special Publication*, No. 92.
- BAILEY, H W, GALE, A S, MORTIMORE, R N, SWIECICKI, A, and WOOD, C J. 1983. The Coniacian - Maastrichtian stages of the United Kingdom, with particular reference to southern England. *Newsletters on Stratigraphy*, Vol. 12, 29-42.
- BERGERAT, F, and VANDYCKE, S. 1994. Paleostress Analysis and Geodynamical Implications of Cretaceous-Tertiary Faulting in Kent and the Boulonnais. *Journal of the Geological Society*, Vol. 151, 439-448.
- BEVAN, T G, and HANCOCK, P L. 1986. A late Cenozoic regional mesofracture system in southern England and northern France. *Journal of the Geological Society of London*, Vol. 143, 355-362.
- BIRCH, G P, and GRIFFITHS, J S. 1996. Engineering geomorphology. 64-75 in *Engineering Geology of the Channel Tunnel*. HARRIS, C S, HART, M B, VARLEY, P M, and WARREN, C D (editors). (London: Thomas Telford.)
- BIRCH, G P, and WARREN, C D. 1996. The cliffs behind the Channel Tunnel workings. 76-87 in *Engineering Geology of the Channel Tunnel*. HARRIS, C S, HART, M B, VARLEY, P M, and WARREN, C D (editors). (London: Thomas Telford.)
- BLOOMFIELD, J P. 1999. Tilmanstone, the UK field site. in *Second Annual Progress Report, Fracflow Project*.
- BLOOMFIELD, J P. 2000. Tilmanstone site. 18-24 in *Third Annual Progress Report, Fracflow Project*.
- BRIDGLAND, D R, and D'OLIER, B. 1995. The Pleistocene evolution of the Thames and Rhine drainage systems in the southern North Sea basin. 27-45 in *Island Britain, a Quaternary perspective*. PREECE, R C (editor). *Special Publication of the Geological Society of London*, No. 96.
- BRISTOW, C R, BARTON, C M, FRESHNEY, E C, WOOD, C J, EVANS, D J, COX, B M, IVIMEY-COOK, H C, and TAYLOR, R T. 1995. Geology of the country around Shaftesbury. *Memoir of the British Geological Survey*. Sheet 313 (England and Wales).
- BRISTOW, C R, MORTIMORE, R N, and WOOD, C J. 1997. Lithostratigraphy for mapping the Chalk of southern England. *Proceedings of the Geologists' Association*, Vol. 108, 293-315.
- BUCKLEY, D K, SMEDLEY, P L, and WILLIAMS, A T. 1996. Report on Phase 2 investigations at Reculver, North Kent. *British Geological Survey Technical Report*, WD/96/66C.

- CARTER, D J, and HART, M B. 1977. Aspects of mid-Cretaceous stratigraphical micropalaeontology. *Bulletin of the British Museum (Natural History)(Geology)*, Vol. 29, 1-135.
- CROSS, G A, RUSHTON, K R, and TOMLINSON, L M. 1995. The East Kent Chalk Aquifer During the 1988-92 Drought. *Journal of the Institution of Water and Environmental Management*, Vol. 9, 37-48.
- CURRY, D. 1981. Thanetian. 255-265 in *Stratotypes of Palaeogene stages*. POMEROL, C (editor). *Mémoire Hors Série du Bulletin d'Information des Géologues du Bassin du Paris*, No. 2.
- DESTOMBES, J P, and SHEPHARD-THORN, E R. 1971. Geological results of the Channel Tunnel site investigation 1964-65. *Institute of Geological Sciences Report*, No. 71/11.
- ELLISON, R A, KNOX, R W O, JOLLEY, D W, and KING, C. 1994. A revision of the lithostratigraphical classification of the early Palaeogene strata of the London Basin and East Anglia. *Proceedings of the Geologists' Association*, Vol. 105, 187-197.
- ENVIRONMENT AGENCY. 2001. Lessons learned Autumn 2000 floods. *Environment Agency*.
- EVANS, D J, and HOPSON, P M. 2000. The seismic expression of synsedimentary channel features within the Chalk of southern England. *Proceedings of the Geologists' Association*, Vol. 111, 219-230.
- FARRANT, A R, and ALDISS, D T. 2002. A geological model of the North Downs of Kent: The River Medway to the River Great Stour. *British Geological Survey Commissioned Report*, CR/02/310.
- GALE, A S. 1989. Field meeting at Folkestone Warren, 29th November, 1987. *Proceedings of the Geologists' Association*, Vol. 100, 73-82.
- GALE, A S. 1996. Turonian correlation and sequence stratigraphy of the Chalk in southern England. 177-195 in *Sequence Stratigraphy in British Geology*. HESSELBRO, S P, and PARKINSON, D N (editors). *Geological Society of London Special Publication*, No. 103.
- GALE, A S, HANCOCK, J M, and KENNEDY, W J. 1999. Biostratigraphical and sequence correlation of the Cenomanian successions in Mangyshlak (W. Kazakhstan) and Crimea (Ukraine) with those in southern England. *Bulletin de L'Institut Royal des Sciences Naturelles de Belgique*, Vol. 69-Supplement A, 67-86.
- GALE, A S, and SMITH, A B. 1982. The palaeobiology of the Cretaceous irregular echinoids *Infulaster* and *Hagenowia*. *Palaeontology*, Vol. 25, 11-42.
- GALLOIS, R W. 1965. *British Regional Geology: The Wealden District* (Fourth edition). (London: HMSO for British Geological Survey.)
- HARRIS, C S, HART, M B, and WOOD, C J. 1996. A revised stratigraphy. 398-420 in *Engineering Geology of the Channel Tunnel*. HARRIS, C S, HART, M B, VARLEY, P M, and WARREN, C D (editors). (London: Thomas Telford.)
- HART, M B, BAILEY, H W, CRITTENDEN, S, FLETCHER, B N, PRICE, R J, and SWIECICKI, A. 1989. Cretaceous. 273-371 in *Stratigraphical Atlas of Fossil Foraminifera* (Second edition). JENKINS, D G, and MURRAY, J W (editors). (Chichester: Ellis Horwood.)
- HEADWORTH, H G, PURI, S, and RAMPLING, B H. 1980. Contamination of a Chalk aquifer by mine drainage at Tilmanstone, East Kent, U.K. *Quarterly Journal of Engineering Geology*, Vol. 13, 105-117.
- HOLMES, S C A. 1981. Geology of the country around Faversham. *Memoir of the British Geological Survey*, Sheet 273.
- HOLMES, S C A. 1987. Marl seams and Chalk stratigraphy; note on an occurrence with nodular beds throughout Kent and Surrey recognised in 1937 as a basal marker of the Upper Chalk. *Proceedings of the Geologists' Association*, Vol. 98, 191.
- JEFFERIES, R P S. 1963. The stratigraphy of the *Actinocamax plenus* Subzone (Turonian) in the Anglo-Paris Basin. *Proceedings of the Geologists' Association*, Vol. 74, 1-33.
- JENKYN, H C, GALE, A S, and CORFIELD, R M. 1994. Carbon-isotope and oxygen-isotope stratigraphy of the English Chalk and Italian Scaglia and its paleoclimatic significance. *Geological Magazine*, Vol. 131, 1-34.
- JONES, H K, and ROBINS, N S. 1999. The Chalk aquifer of the South Downs. *Hydrogeological Report Series of the British Geological Survey*.

- JUKES-BROWNE, A J. 1880. The subdivision of the Chalk. *Geological Magazine*, Vol. 17 [decade 2, Vol. 7], 248-257.
- JUKES-BROWNE, A J, and HILL, W. 1903. The Cretaceous rocks of Britain. Vol. II. The Lower and Middle Chalk of England. *Memoir of the Geological Survey of the United Kingdom*.
- JUKES-BROWNE, A J, and HILL, W. 1904. The Cretaceous rocks of Britain. Vol. III. The Upper Chalk of England. *Memoir of the Geological Survey of the United Kingdom*.
- LUCAS, J. 1908. The hydrogeology of the Dover Basin, Dover Harbour and the Channel Tunnel: the position of the East Kent Coalfield. *Transactions of the Surveyors Institution*, Vol. 40, 455-482.
- MORTIMORE, R N. 1983. The stratigraphy and sedimentation of the Turonian-Campanian in the southern province of England. *Zitteliana*, Vol. 10, 27-41.
- MORTIMORE, R N. 1986a. Stratigraphy of the Upper Cretaceous White Chalk of Sussex. *Proceedings of the Geologists' Association*, Vol. 97, 97-139.
- MORTIMORE, R N. 1986b. Controls on Upper Cretaceous sedimentation in the South Downs with particular reference to flint distribution. 21-42 in *The scientific study of flint and chert*.
- SIEVEKING, G D G, and HART, M B (editors). Proceedings of the Fourth International Flint Symposium held at Brighton Polytechnic, 10-15 April 1983. (Cambridge: Cambridge University Press.)
- MORTIMORE, R N. 1987. Upper Cretaceous chalk in the North and South Downs, England: a correlation. *Proceedings of the Geologists' Association*, Vol. 98, 77-86.
- MORTIMORE, R N. 1993. Chalk, water and engineering geology. 67-92 in *The hydrogeology of the Chalk of north-west Europe*. DOWNING, R A, PRICE, M, and JONES, G P (editors). (Oxford: Oxford Science Publications. Clarendon Press.)
- MORTIMORE, R N. 1997. *The Chalk of Sussex and Kent*. Geologists' Association Guide. No. 57.
- MORTIMORE, R N, and POMEROL, B. 1987. Correlation of the Upper Cretaceous White Chalk (Turonian to Campanian) in the Anglo-Paris Basin. *Proceedings of the Geologists' Association*, Vol. 98, 97-143.
- MORTIMORE, R N, and POMEROL, B. 1991. Upper Cretaceous tectonic disruptions in a placid chalk sequence in the Anglo-Paris Basin. *Journal of the Geological Society of London*, Vol. 148, 391-404.
- MORTIMORE, R N, and POMEROL, B. 1996. A revision of Turonian litho- and biostratigraphy in the Anglo-Paris Basin. *Mitteilungen aus dem Geologisch-Paläontologisch Institut der Universität Hamburg*, Vol. 77, 423-441.
- MORTIMORE, R N, POMEROL, B, and FOORD, R J. 1990. Engineering stratigraphy and palaeogeography for the Chalk of the Anglo-Paris Basin. 47-61 in *Chalk*. BURLAND, J B, MORTIMORE, R N, ROBERTS, L D, JONES, D L, and CORBETT, B O (editors). Proceedings of the International Chalk Symposium held at Brighton Polytechnic on 4-7 September 1989. (London: Thomas Telford.)
- MORTIMORE, R N, and WOOD, C J. 1986. The distribution of flint in the English Chalk, with particular reference to the 'Brandon Flint Series' and the high Turonian flint maximum. 7-20 in *The Scientific Study of Flint and Chert: Proceedings of the Fourth International Flint Symposium held at Brighton Polytechnic, 10-15 April 1983*. SIEVEKING, G D G, and HART, M B (editors). (Cambridge: Cambridge University Press.)
- MORTIMORE, R N, WOOD, C J, and GALLOIS, R W. 2001. *British Upper Cretaceous Stratigraphy*. Geological Conservation Review Series. No. 23. (Peterborough: Joint Nature Conservation Committee.)
- MORTIMORE, R N, WOOD, C J, POMEROL, B, and ERNST, G. 1998. Dating the phases of the Subhercynian tectonic epoch: Late Cretaceous tectonics and eustatics in the Cretaceous basins of northern Germany compared with the Anglo-Paris Basin. *Zentralblatt für Geologie und Paläontologie*, Vol. 1, 1349-1401.
- MURRAY, K H. 1986. Correlation of electrical resistivity marker bands in the Cenomanian and Turonian Chalk from the London Basin to east Yorkshire. *British Geological Survey Report*, Vol. 17, No. 8.

- PRICE, F G H. 1877. On the beds between the Gault and Upper Chalk near Folkestone. *Quarterly Journal of the Geological Society of London*, Vol. 33, 431-448.
- RAWSON, P F. 1992. The Cretaceous. 355-388 in *Geology of England and Wales*. DUFF, P M D, and SMITH, A J (editors). (London: The Geological Society.)
- RAWSON, P F, ALLEN, P W, and GALE, A S. 2001. The Chalk Group - a revised lithostratigraphy. *Geoscientist*, Vol. 11, 21.
- REYNOLDS, D H B. 1948. The movement of water in the Middle and Upper Chalk of the River Dour catchment. *Journal of the Institution of Civil Engineers*, Vol. 29, 73-108.
- REYNOLDS, D H B. 1955. Discussion of Folkestone Warren Landslips: Investigations and remedial measures. *Proceedings of the Institution of Civil Engineers*, 444-449.
- REYNOLDS, D H B. 1970. Underdraining of the lower Chalk of south east Kent. *Journal of the Institution of Water Engineers*, Vol. 24, 471-480.
- RIPPON, J H, GAYER, R A, and MILIORIZOS, M. 1997. Variscan structures in the Kent coalfield, southeast England, and their regional significance. *Geological Magazine*, Vol. 134, 855-867.
- ROBASZYNSKI, F, and AMEDRO, F. 1986. The Cretaceous of the Boulonnais (France) and a comparison with the Cretaceous of Kent (United Kingdom). *Proceedings of the Geologists' Association*, Vol. 97, 171-212.
- ROBINSON, N D. 1986. Lithostratigraphy of the Chalk Group of the North Downs, southeast England. *Proceedings of the Geologists' Association*, Vol. 97, 141-170.
- ROBINSON, N D. 1987. Upper Cretaceous Chalk in the North and South Downs, England: a reply. *Proceedings of the Geologists' Association*, Vol. 98, 87-93.
- SHARP, J C, WARREN, C D, BARTON, N R, and MUIR WOOD, R. 1996. Fundamental evaluations of the Chalk Marl for the prediction of UK marine tunnel stability and water inflows. 472-507 in *Engineering geology of the Channel Tunnel*. (London, United Kingdom: Thomas Telford.)
- SHEPHARD-THORN, E R. 1988. Geology of the country around Ramsgate and Dover. *Memoir of the Geological Survey of Great Britain*, Sheets 274 and 279 (England and Wales).
- SHEPHARD-THORN, E R, LAKE, R D, and ATITULLAH, E A. 1972. Basement control of structures in the Mesozoic rocks in the Strait of Dover region, and its reflection in certain features of the present land and submarine topography. *Philosophical Transactions of the Royal Society*, Vol. A272, 99-113.
- SMART, J G O, BISSON, G, and WORSSAM, B C. 1966. Geology of the Country around Canterbury and Folkestone. *Memoir of the Geological Survey of Great Britain*, Sheets 289, 305 and 306 (England and Wales).
- SMEDLEY, P L. 1999. Management of coastal aquifers in Europe, palaeowaters, natural controls and human influence. Chapter 5 in *Final Report of EC Fourth Framework Programme Contract ENV4-CT95-0156, June 1999*. EDMUNDS, W M, and MILNE, C J (editors).
- SWIECICKI, A. 1980. A foraminiferal biostratigraphy of the Campanian and Maastrichtian chalks of the United Kingdom. PhD thesis, Plymouth Polytechnic.
- WARD, D J. 1977. The Thanet Beds exposure at Pegwell Bay, Kent. *Tertiary Research*, Vol. 1, 69-76.
- WARREN, S T, and HARRIS, C S. 1996. An interpretation of the structural geology. 421-435 in *Engineering Geology of the Channel Tunnel*. HARRIS, C S, HART, M B, VARLEY, P M, and WARREN, C D (editors). (London: Thomas Telford.)
- WHITAKER, W. 1908. The water supply of Kent. *Memoir of the Geological Survey of England and Wales*.
- WILKINSON, I P. 2000. A preliminary foraminiferal biozonation of the Chalk Group. *British Geological Survey Internal Report*, IR/00/13.
- WILKINSON, I P. 2003. Late Cretaceous foraminifera from Lower Venson Farm Borehole. *British Geological Survey Internal Report*, IR/03/143.
- WOOD, C J, SHEPHARD-THORN, E R, and HARRIS, C S. 1996. Stratigraphy and regional geology. 29-56 in *Engineering Geology of the Channel Tunnel*. HARRIS, C S, HART, M B, VARLEY, P M, and WARREN, C D (editors). (London: Thomas Telford.)

WOODS, M A. 1999. Lithostratigraphical correlation of borehole resistivity logs from the Chalk of the Beaconsfield district and adjoining areas. *British Geological Survey Technical Report*, WH/99/66R.

WOODS, M A. 2000. The stratigraphy of the Chalk Group of the Saffron Walden district (Sheet 205) in the context of updated lithostratigraphical nomenclature. *British Geological Survey Technical Report*, WH/00/28R.

WOODS, M A. 2001. Lithostratigraphical interpretation of borehole geophysical logs in the Chalk Group of the Berkshire Downs. *British Geological Survey Internal Report*, IR/01/150.

WOODS, M A. 2002. Correlation and lithostratigraphical interpretation of borehole geophysical logs in the Chalk Group of the North Downs. *British Geological Survey Commissioned Report*, CR/02/247.

Figure 1: Location and outline geology of the project area

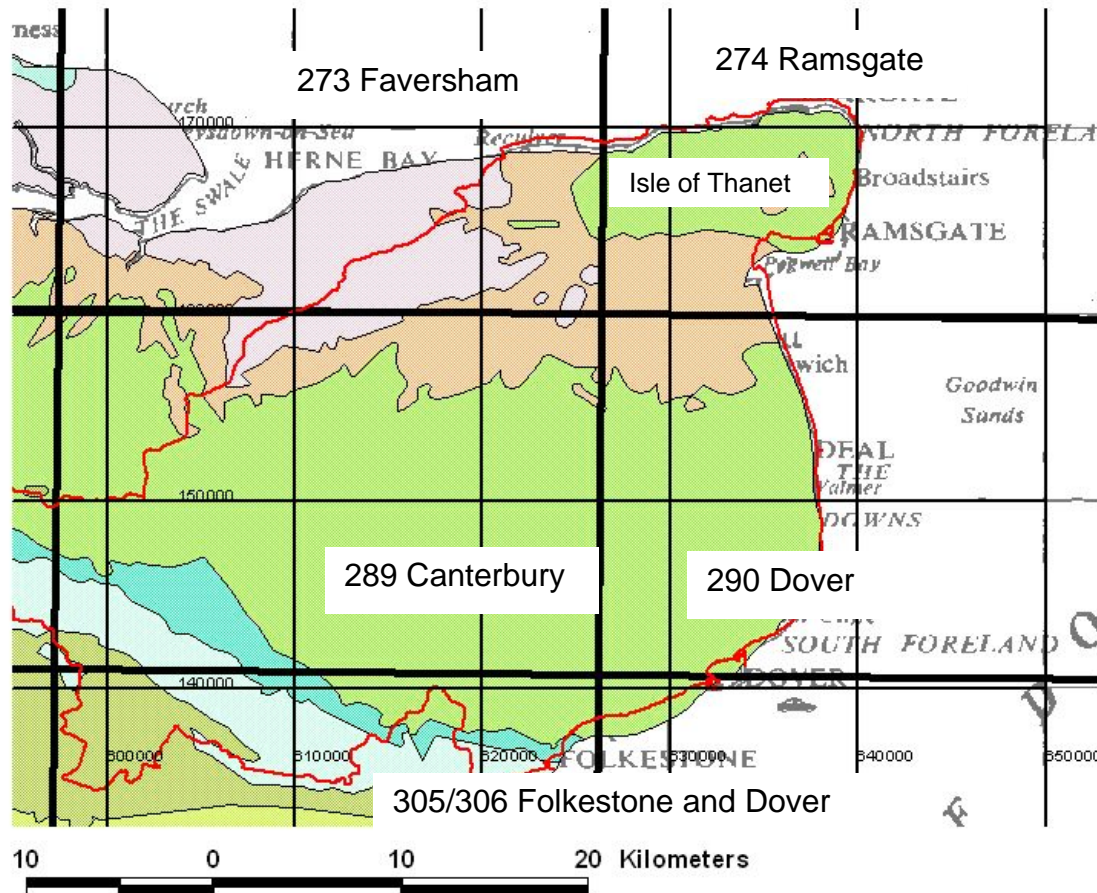

Geology after

1:625 000 geological map

Green: Chalk

Brown: Palaeogene

(pre-London Clay)

Lilac: London Clay

Outline of River Great Stour

catchment area indicated by red line

Outline of coincident 1:50 000 scale
geological sheets indicated by thick
black line

Figure 2: Bedrock geology of East Kent

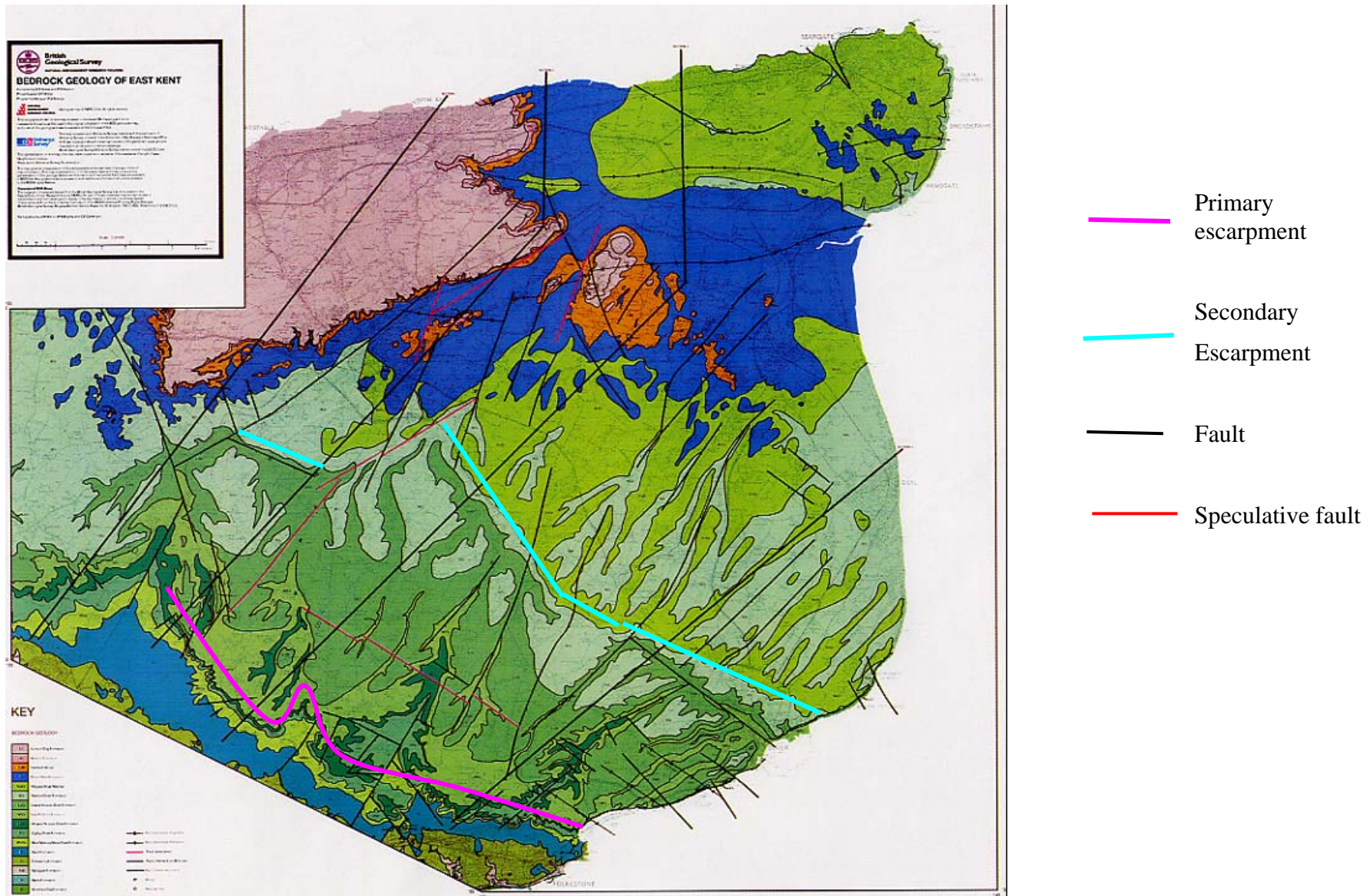
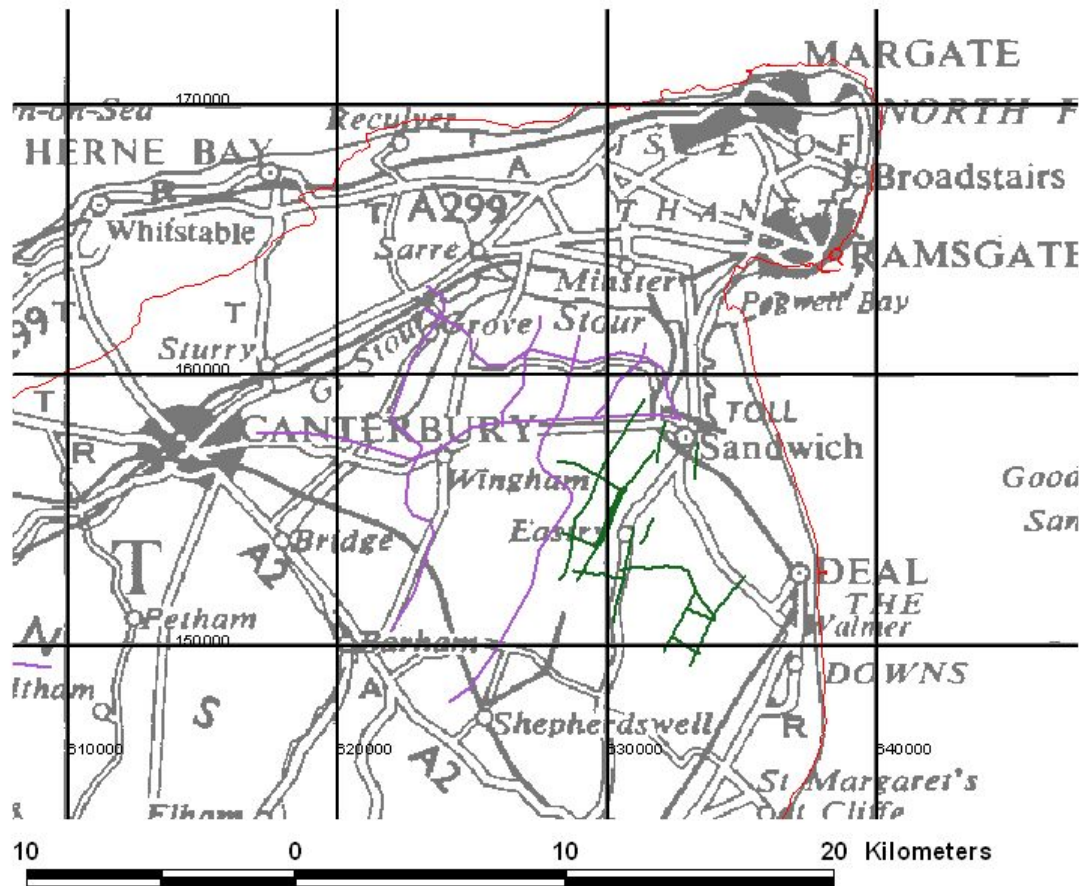

Figure 3: Location of seismic survey lines



Green: Coal Authority seismic surveys

Lilac: Hydrocarbons exploration seismic surveys

Outline of River Great Stour catchment area indicated by red line

Figure 4: Resistivity log and stratigraphical interpretation of the St. Margarets at Cliffe (C1 Seaview) Borehole

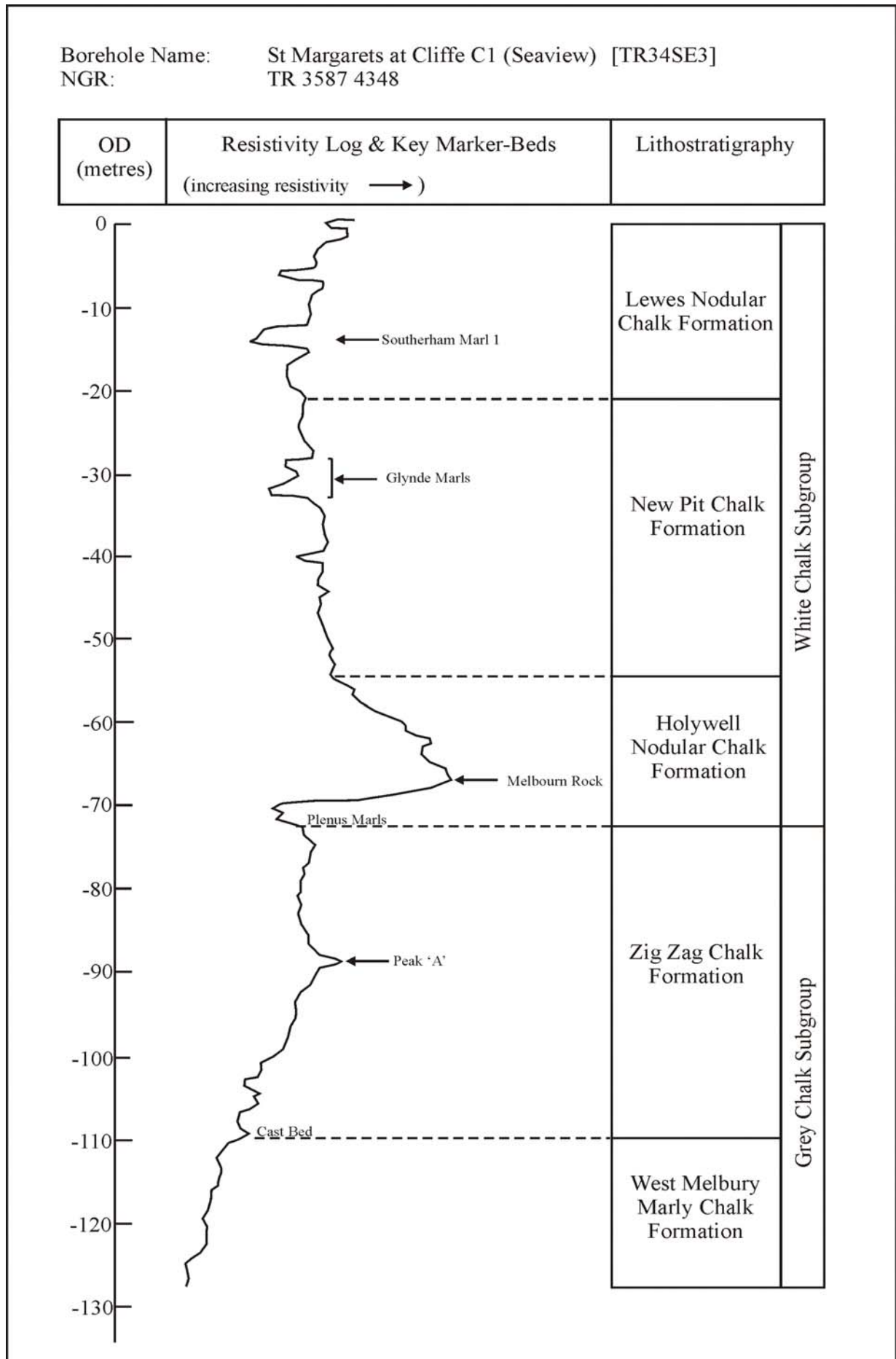

Figure 5: Resistivity log and stratigraphical interpretation for the Dover 1 Aycliff (cored) Borehole

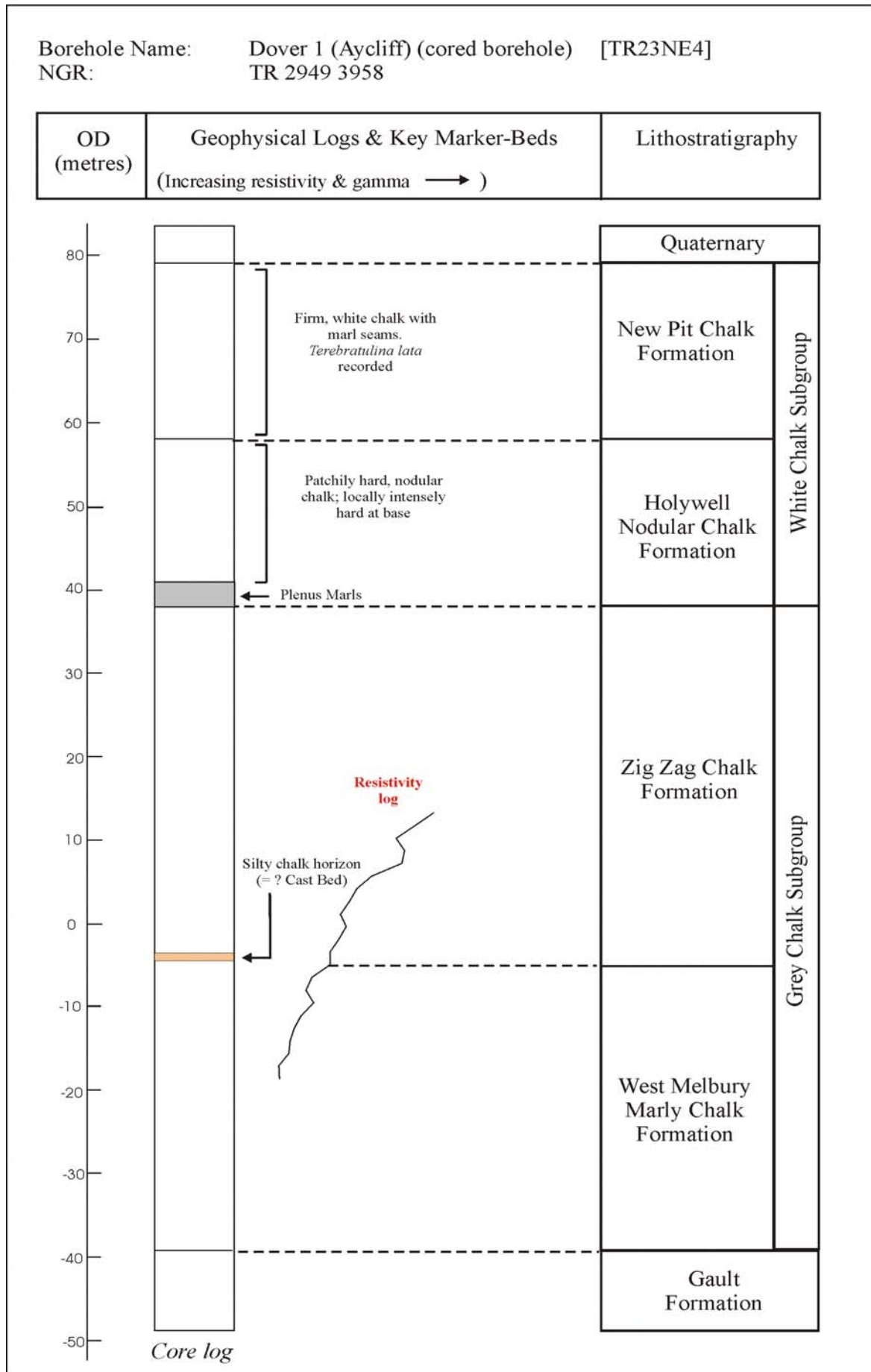

Figure 6: Resistivity log and stratigraphical interpretation of the Lower Venson Farm (cored) Borehole

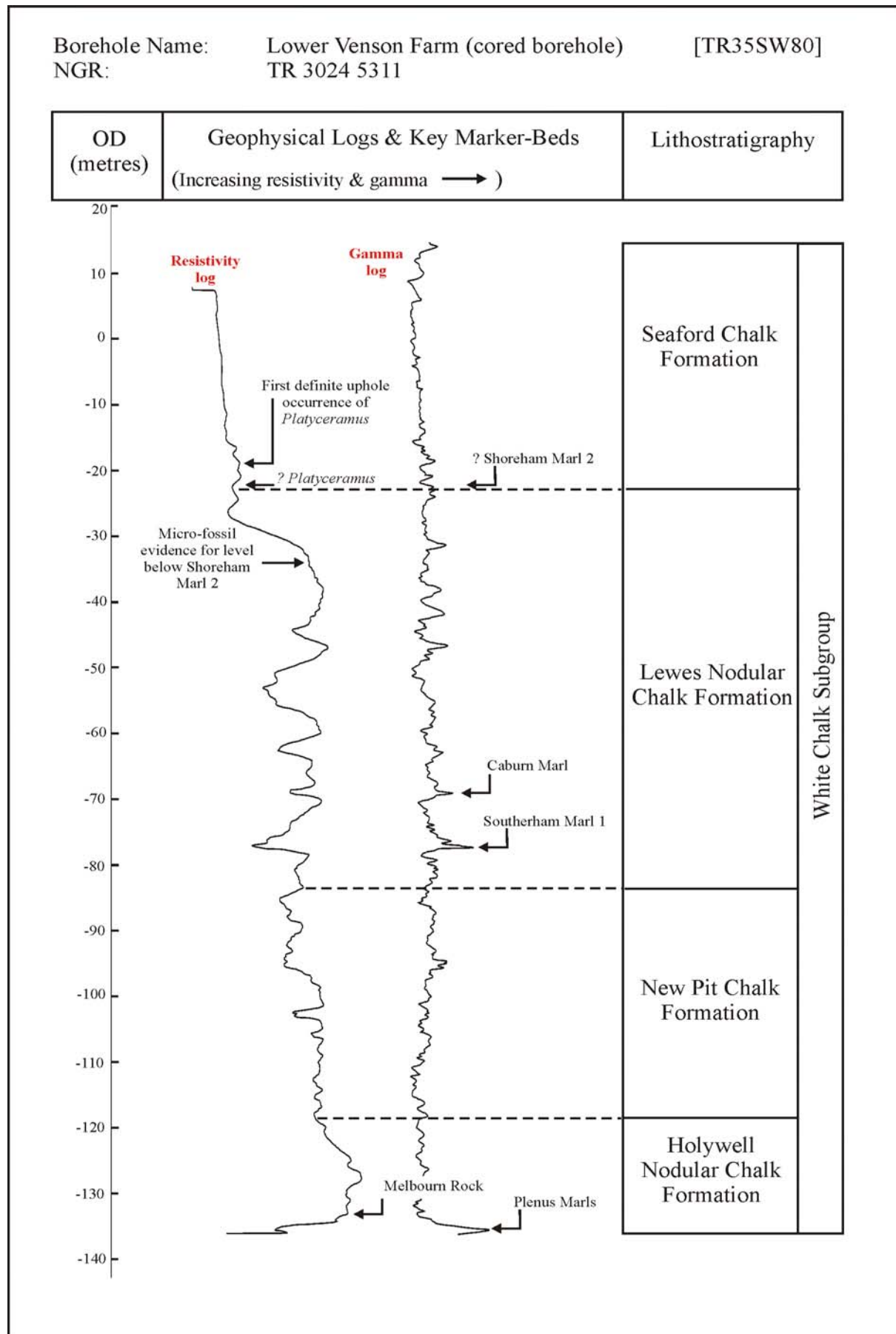

Figure 7: Correlation of lithostratigraphical units and marker horizons between key boreholes in East Kent

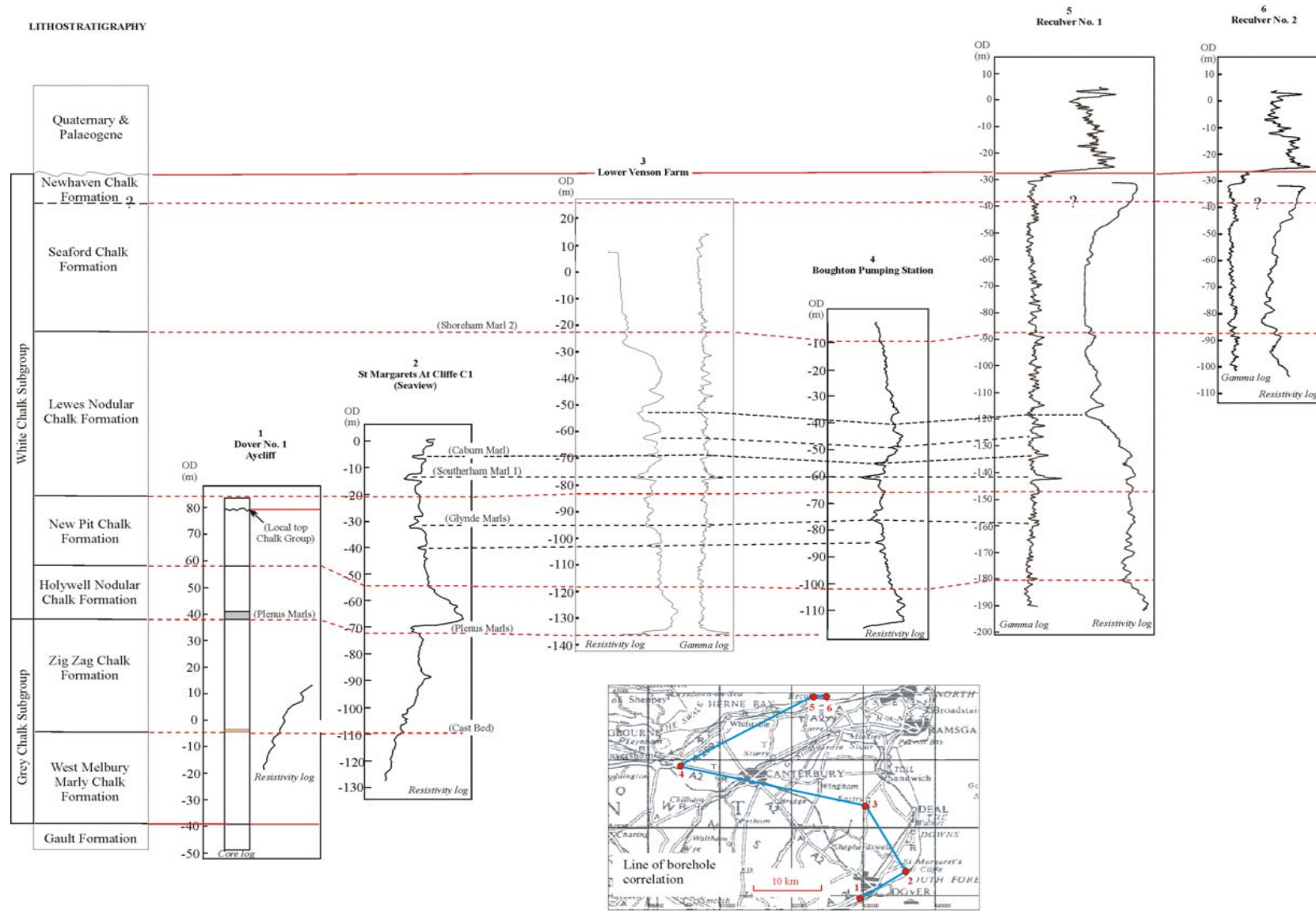

Figure 8: Correlation of lithostratigraphical units between key boreholes in East Kent using OD as a common datum

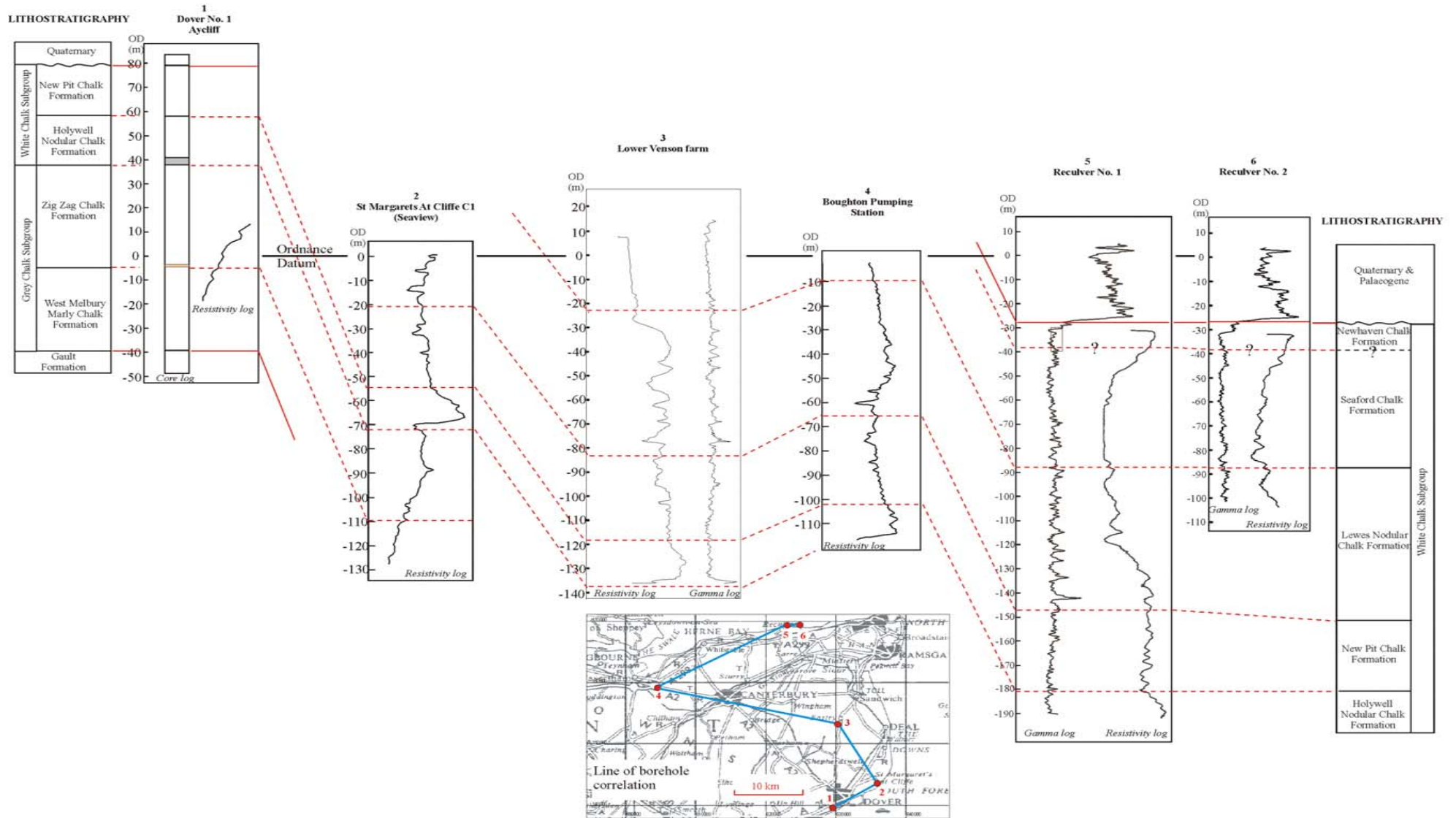

Figure 9: Resistivity log and stratigraphical interpretation of the Boughton Pumping Station Borehole

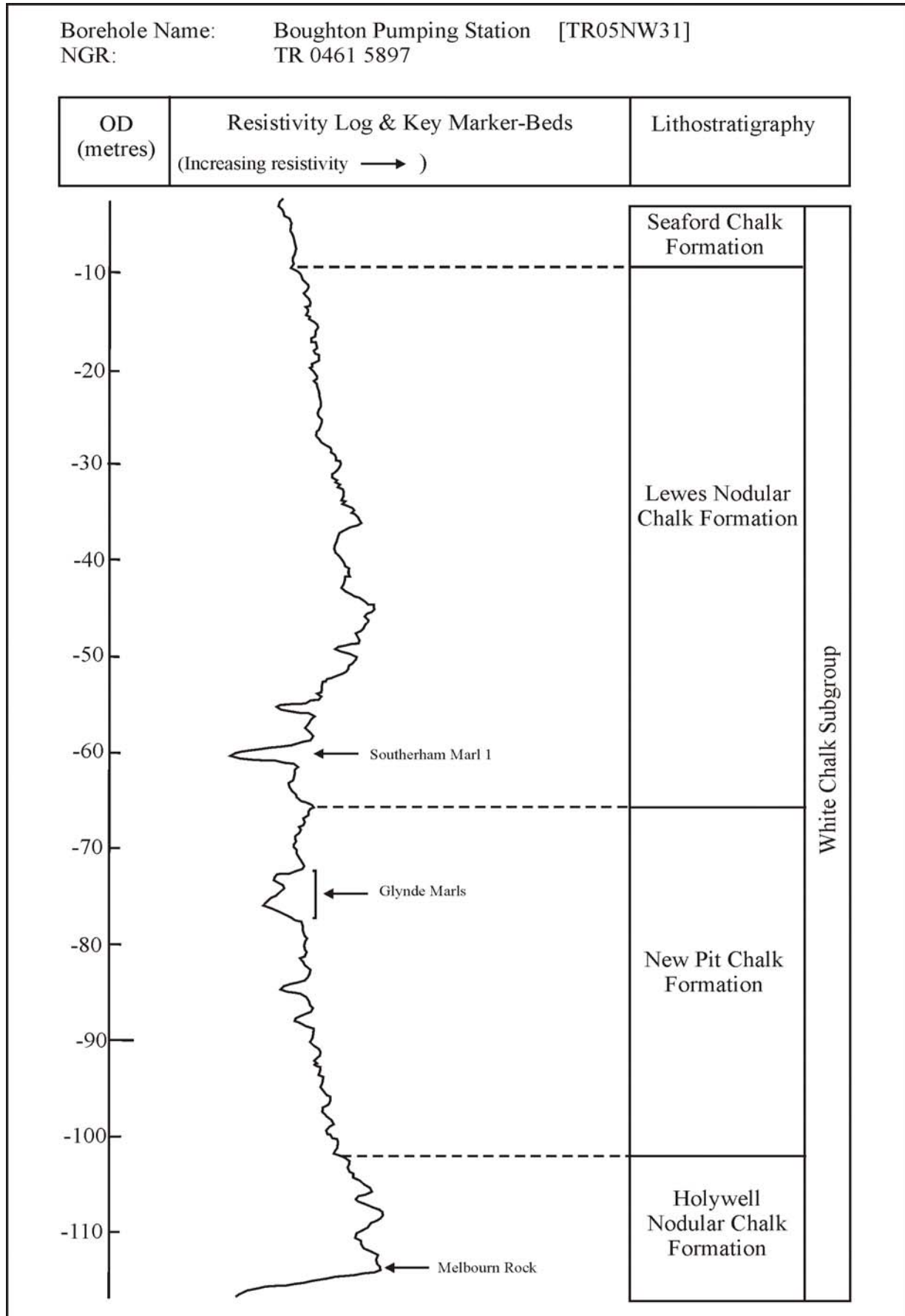

Figure 10: Resistivity log and stratigraphical interpretation of the Reculver 1 Borehole

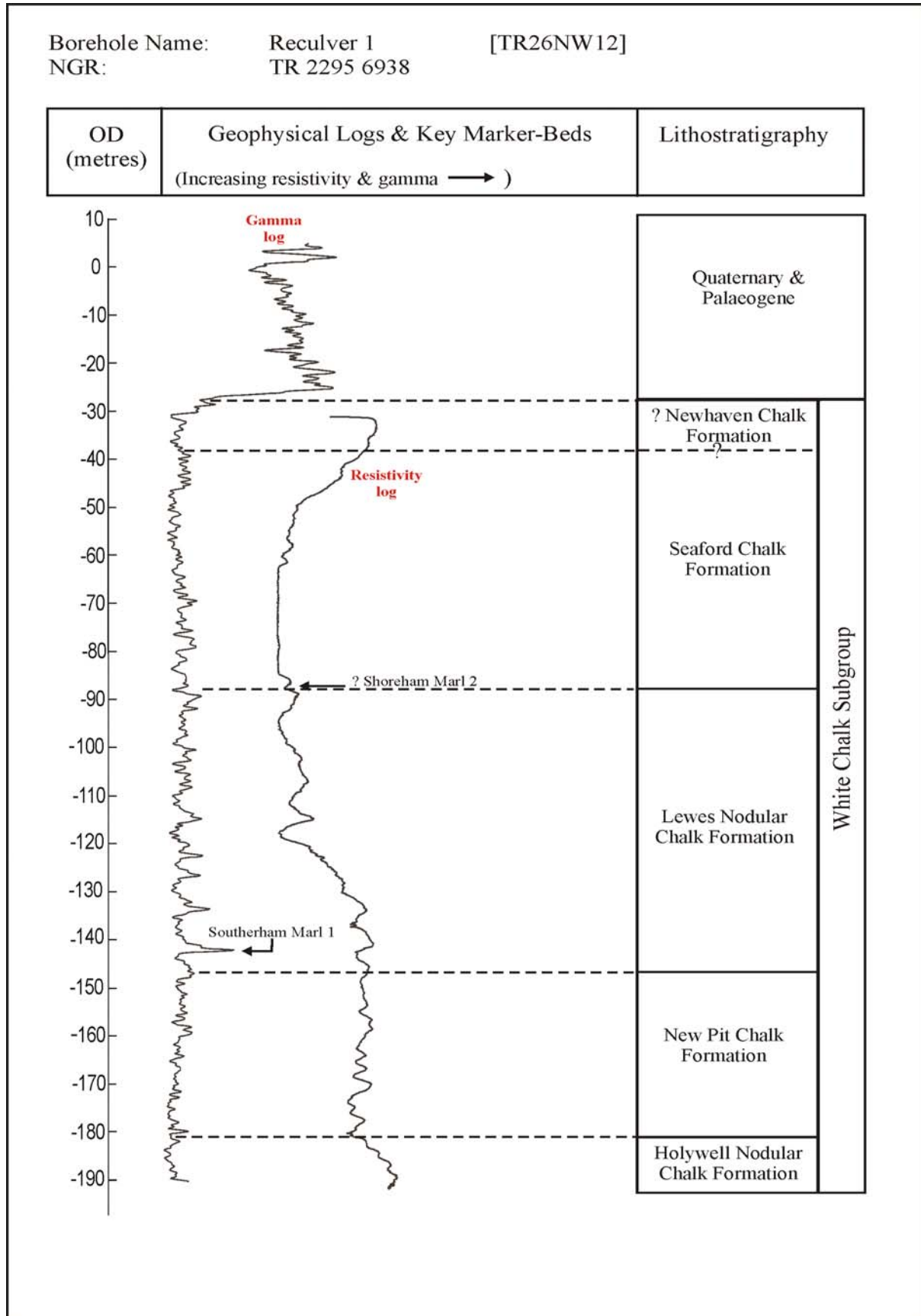

Figure 11: Resistivity log and stratigraphical interpretation of the Reculver 2 Borehole

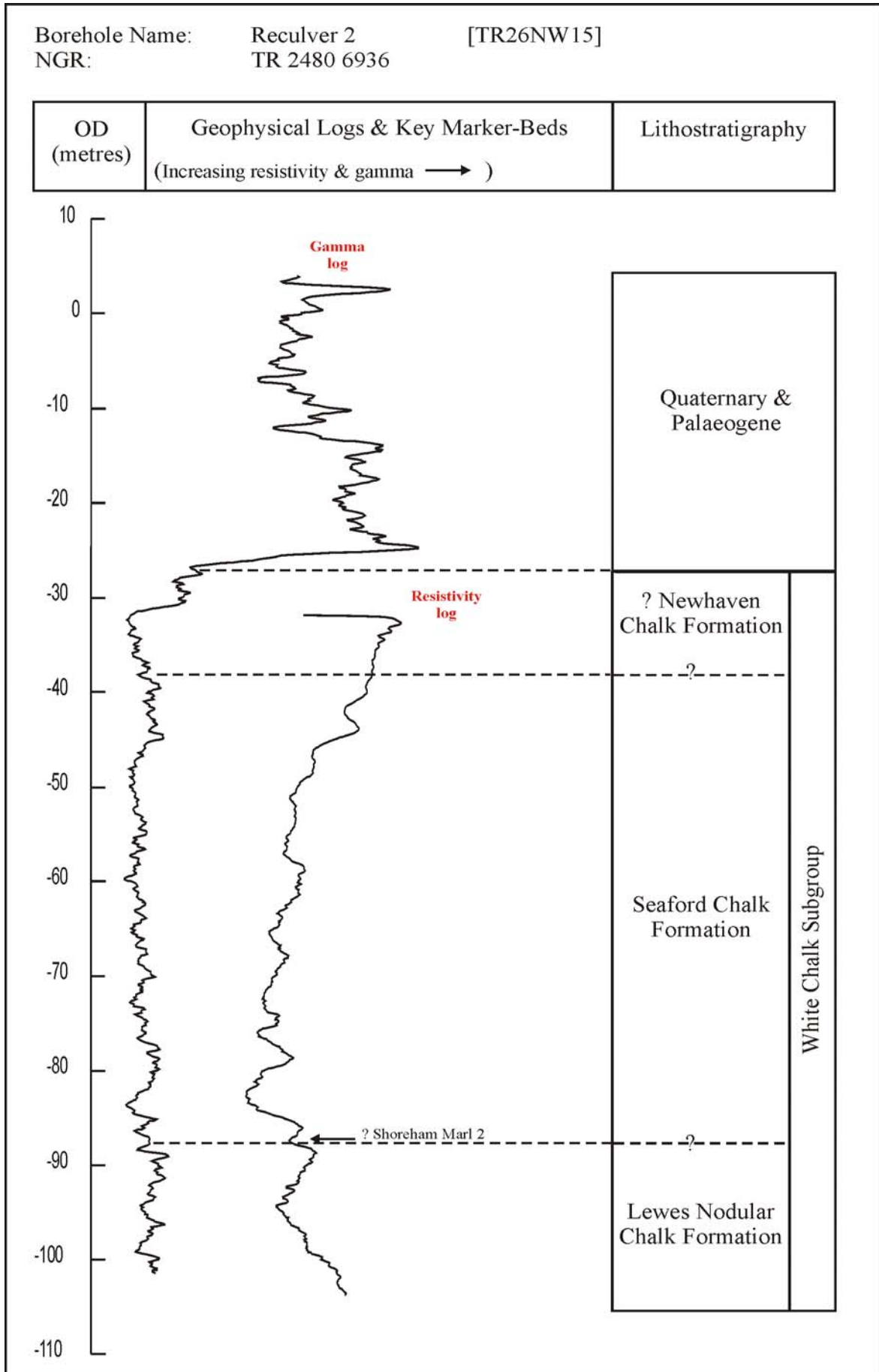

Figure 12: Bedrock geology of North Kent and East Kent

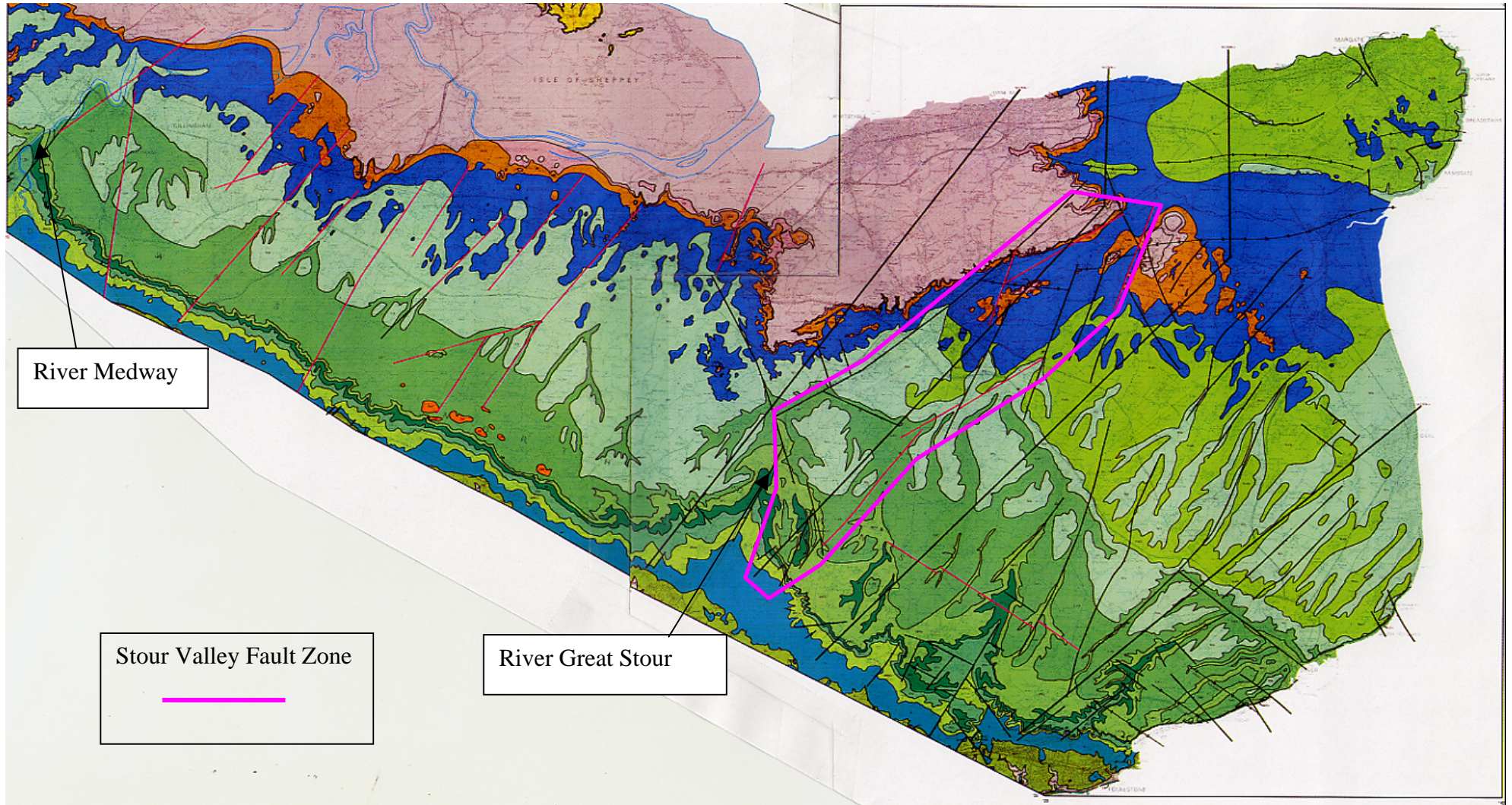

Figure 13: Slope aspect analysis of East Kent

Slope aspect analysis - East Kent

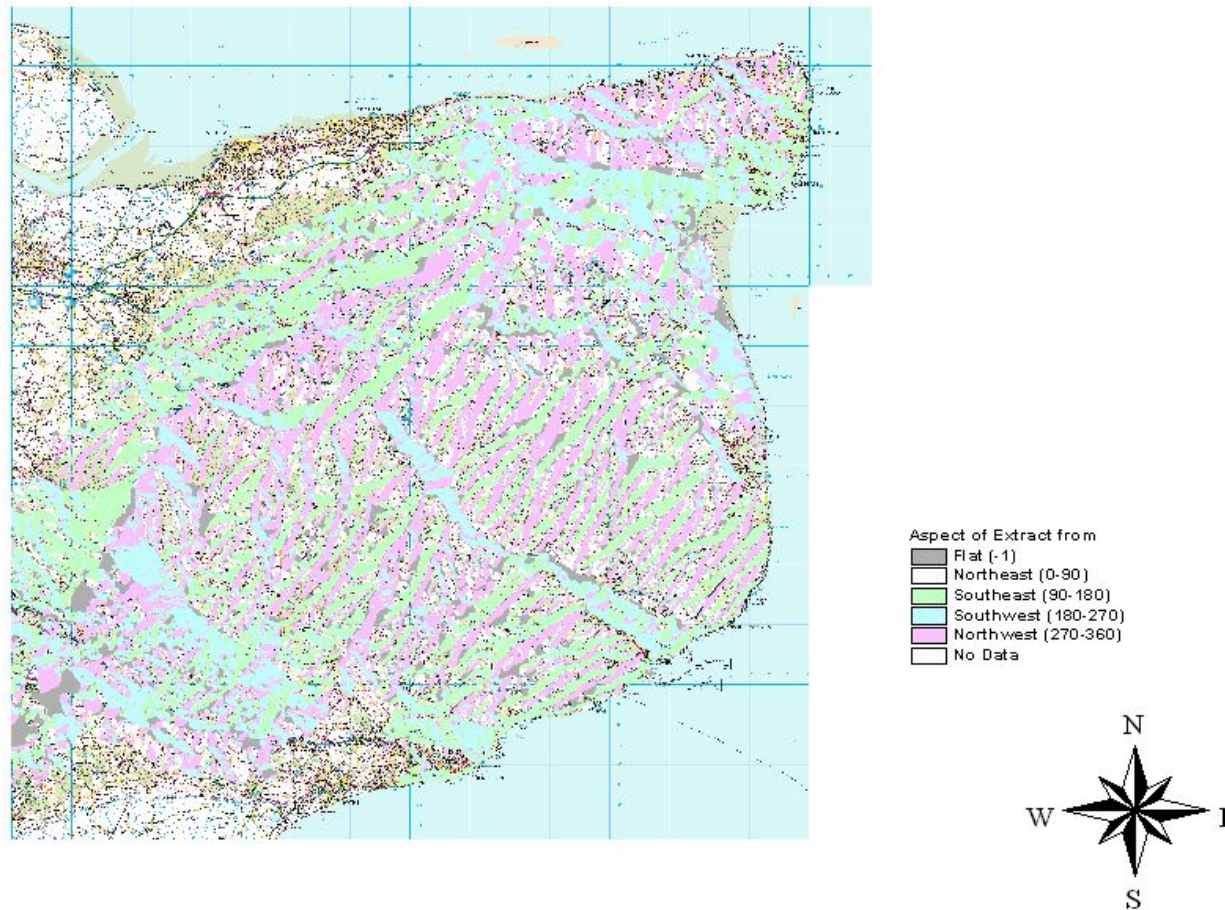
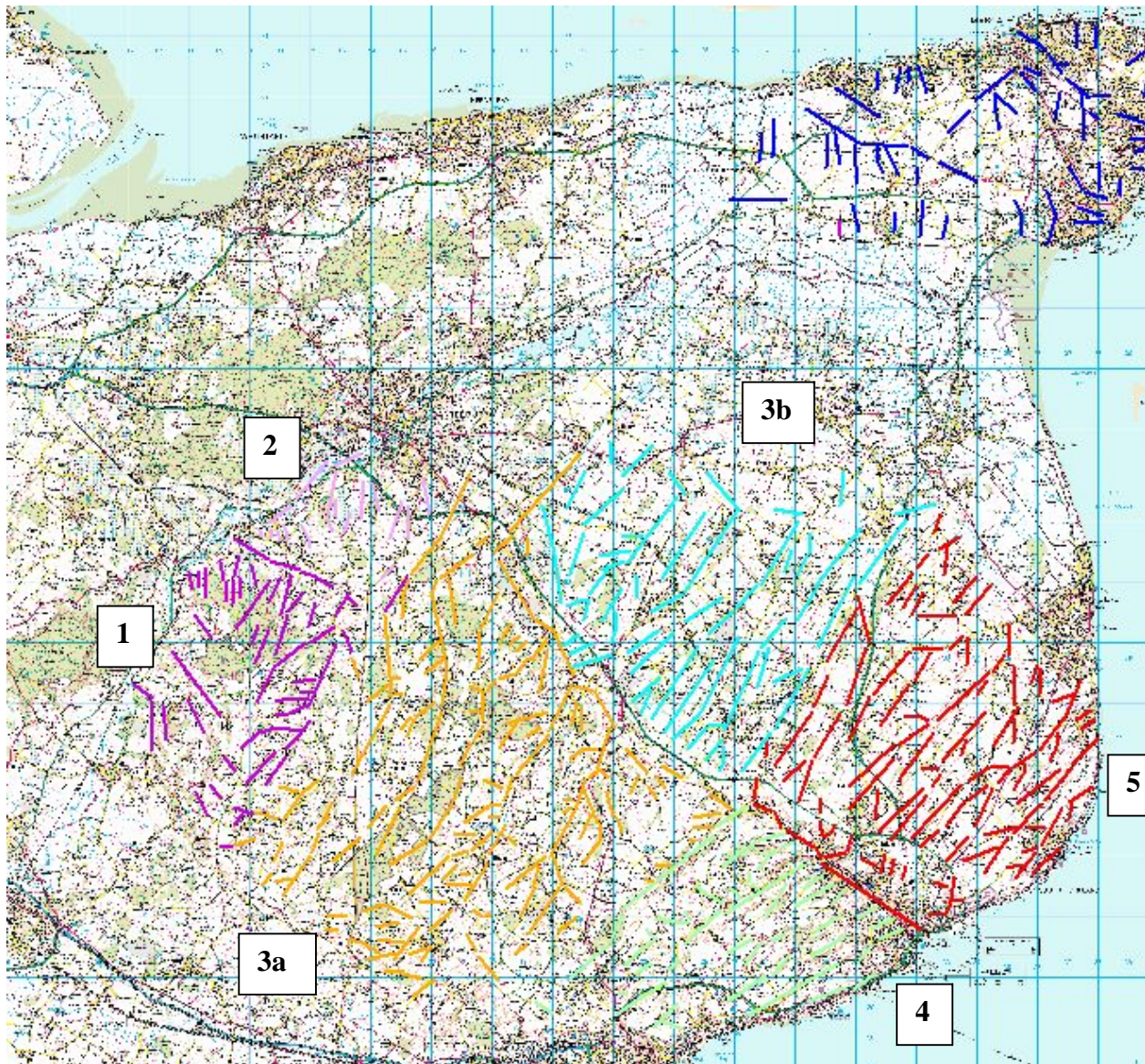

Figure 14: Valley lineaments in East Kent: subdivision by 'geological' criteria



6

Lineament domain	colour	by
Domain 1:	magenta	
Domain 2:	lilac	
Domain 3a:	yellow	
Domain 3b:	pale blue	
Domain 4:	pale green	
Domain 5:	red	
Domain 6:	blue	

Figure 15: Valley lineaments in East Kent: subdivision by 'topographic' criteria

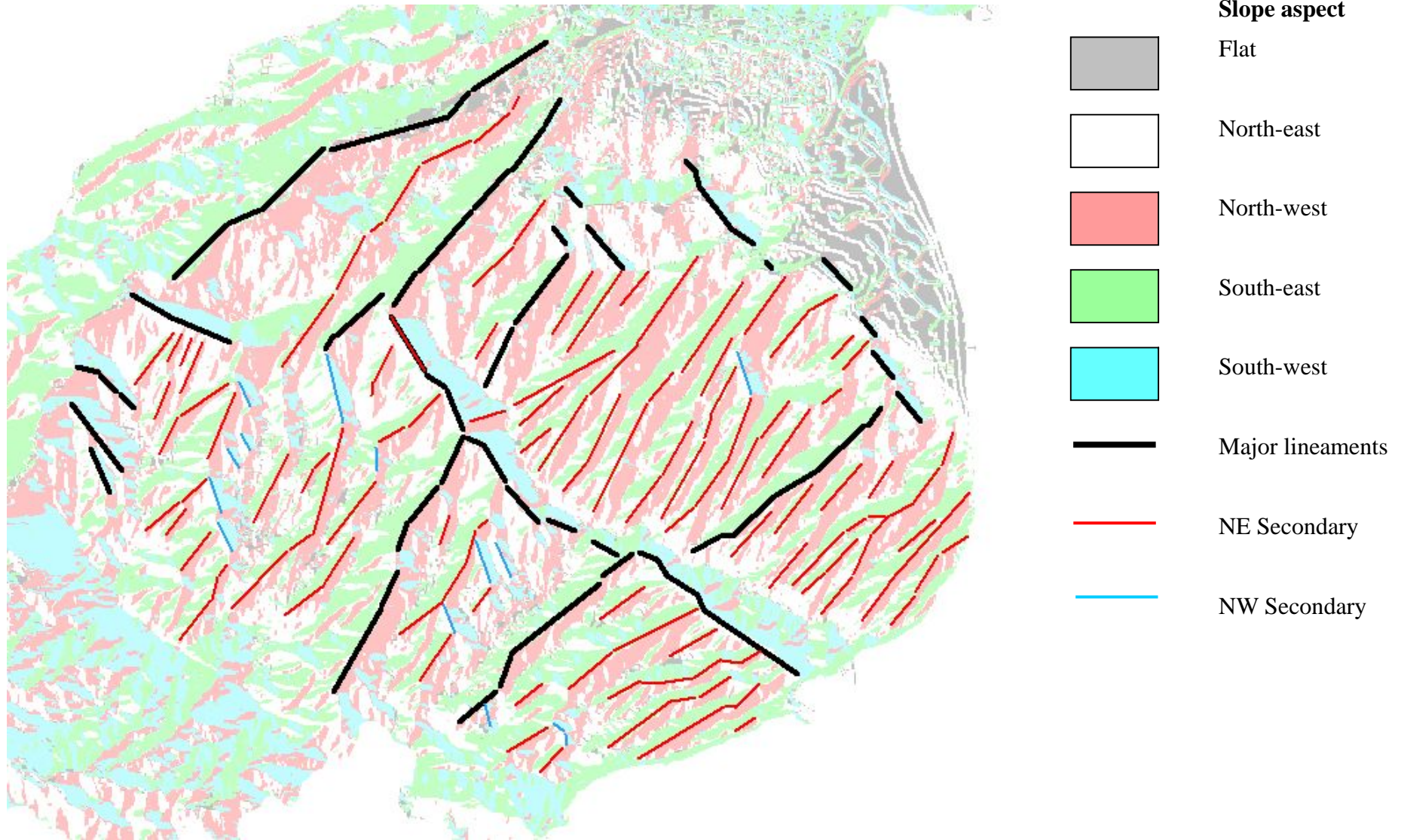
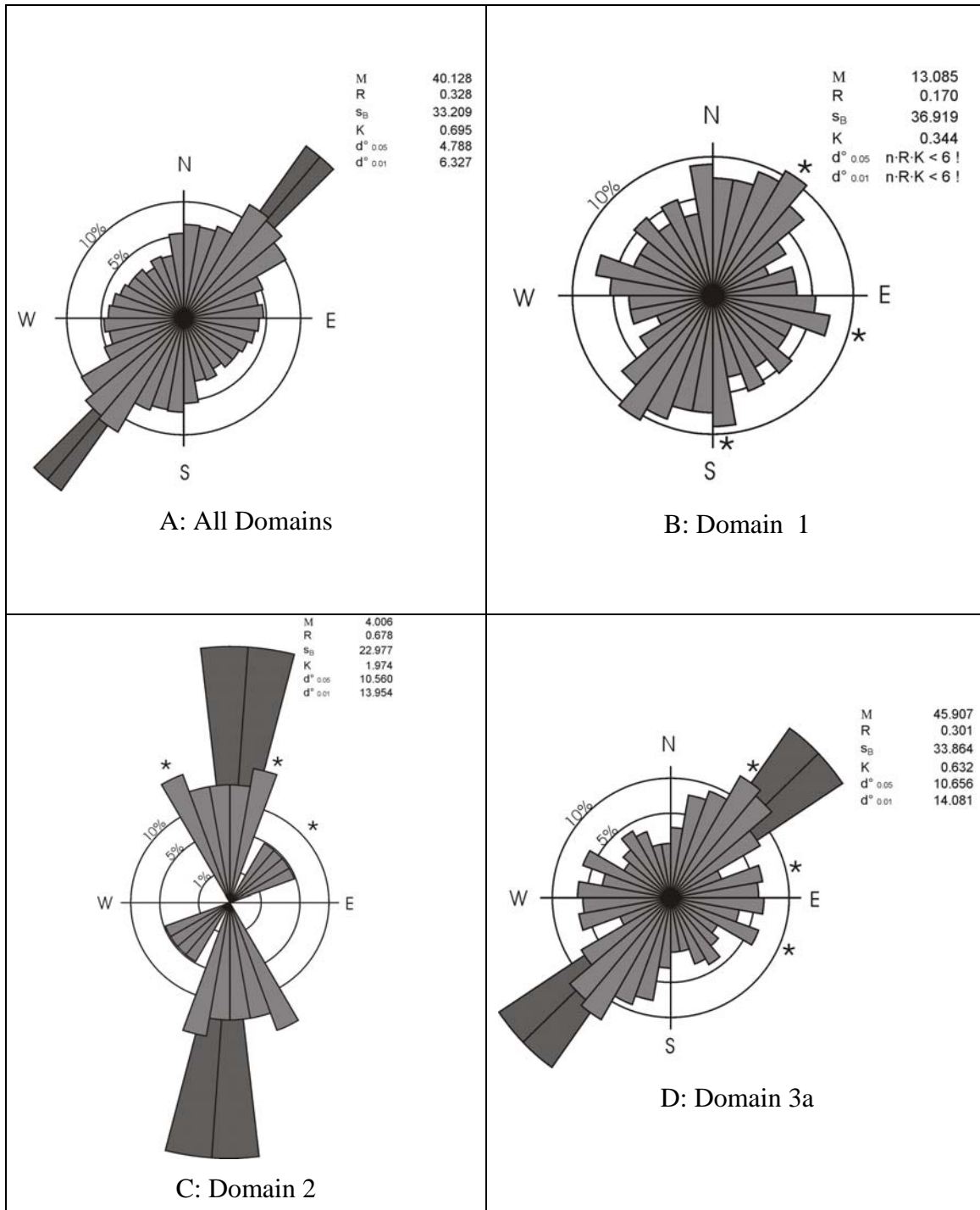

Figure 16: Valley lineaments in the Chalk of East Kent – ‘geological’ subdivision

Pale grey sectors: azimuthal distribution of linear valley elements, in 10° sectors

Dark grey sectors: Mean vector orientation with 95% confidence limits

* Apparent peak in distribution



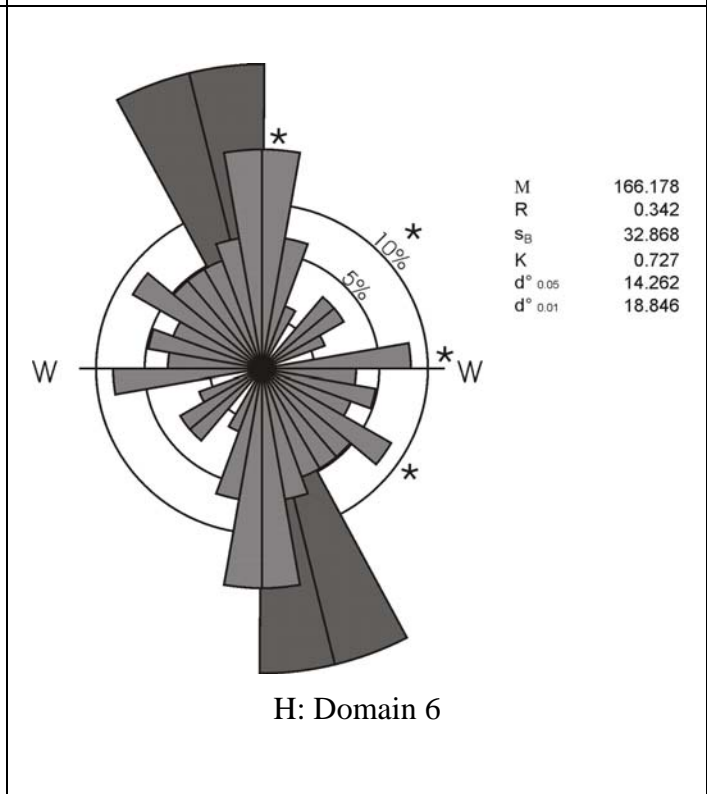
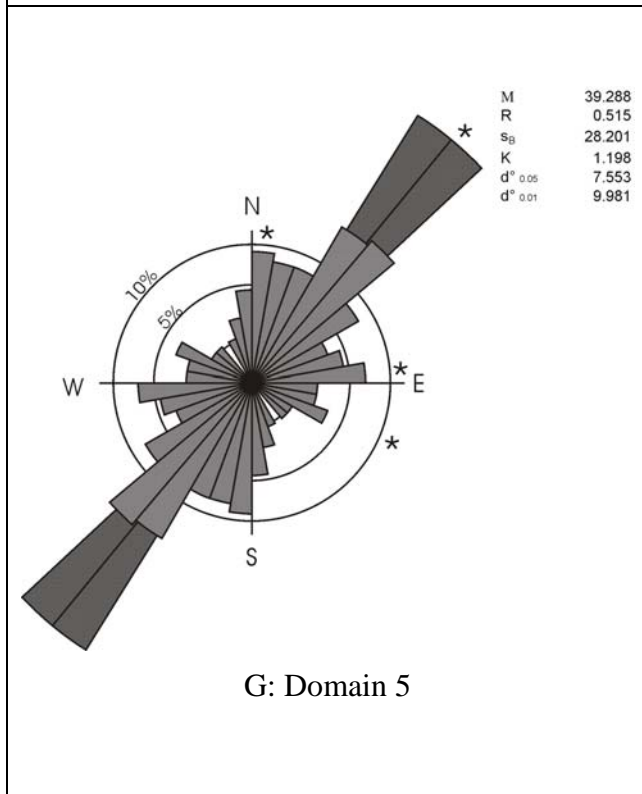
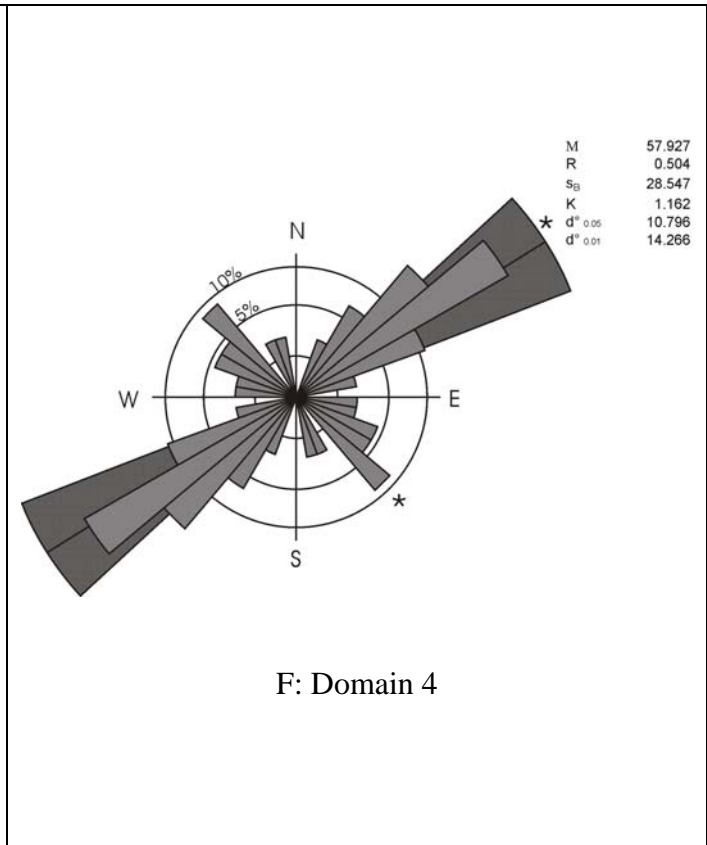
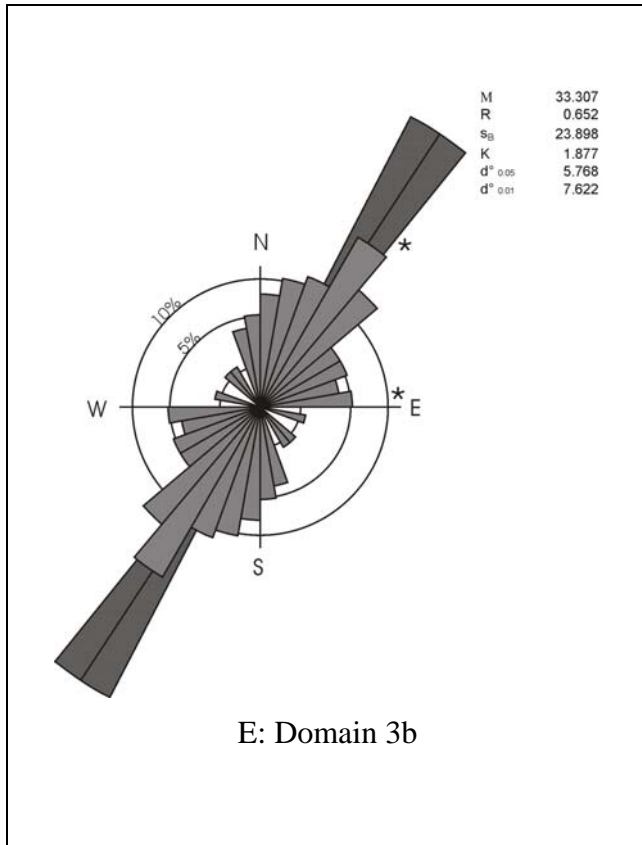
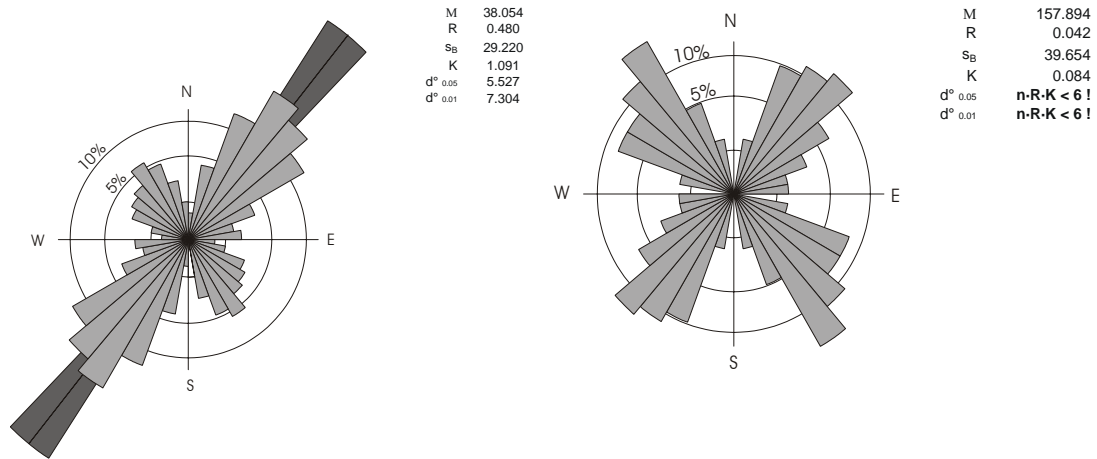
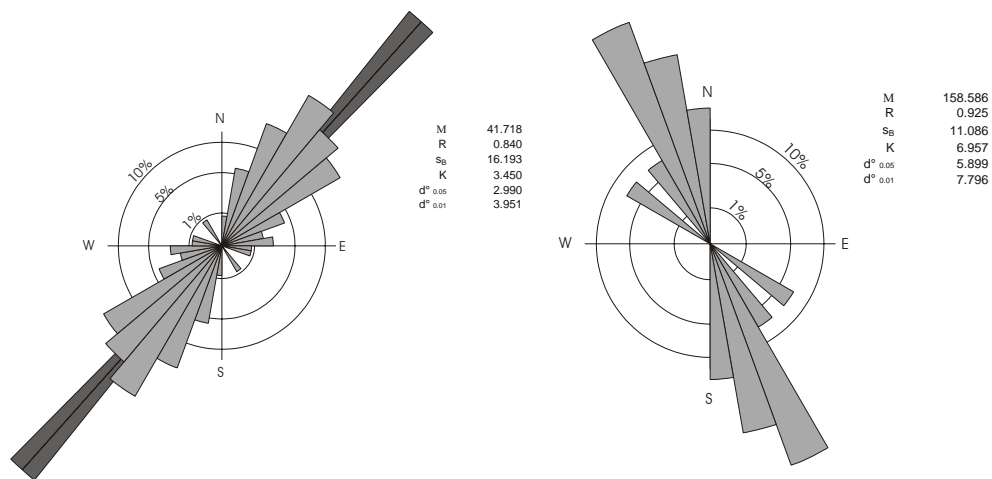

Figure 17: Valley lineaments in the Chalk of East Kent – ‘topographic’ subdivision



A: All lineaments

B: Major lineaments



C: NE-SW secondary lineaments

D: NNW-SSE secondary lineaments

Figure 18: Typical geophysical log profiles of Chalk formations showing named horizons, Boughton ABH1

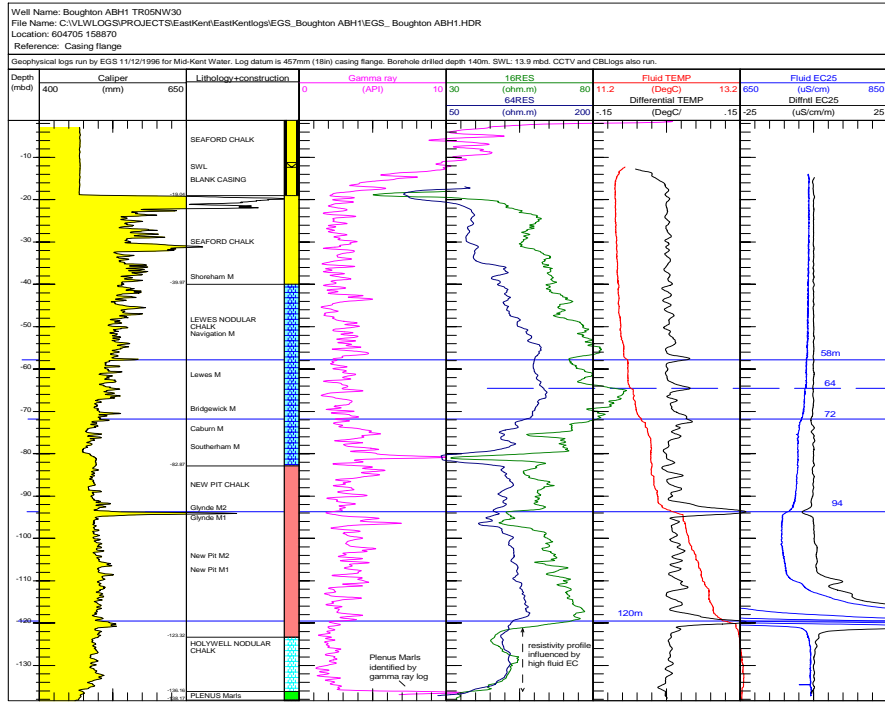

Figure 19: Comparison of gamma ray logs of Palaeogene and Chalk formations, Hoath and Reculver boreholes

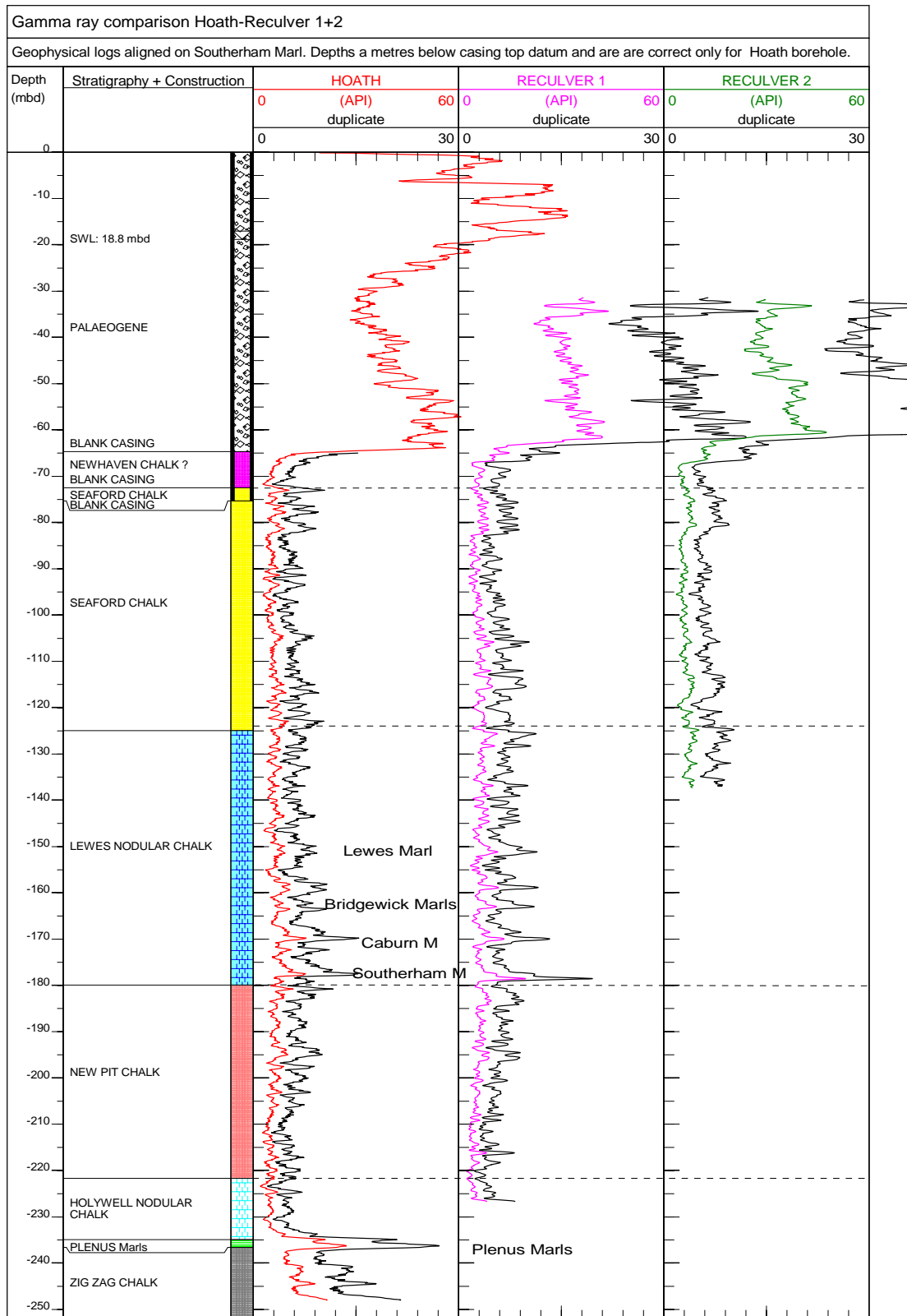

Figure 8.2 Comparison of gamma ray logs of Palaeogene and Chalk Formations, Hoath and Reculver boreholes

Figure 20: Geophysical logs showing well bore flow of groundwater between fissured horizons and entry of brackish water, Dover-Deal borehole C6

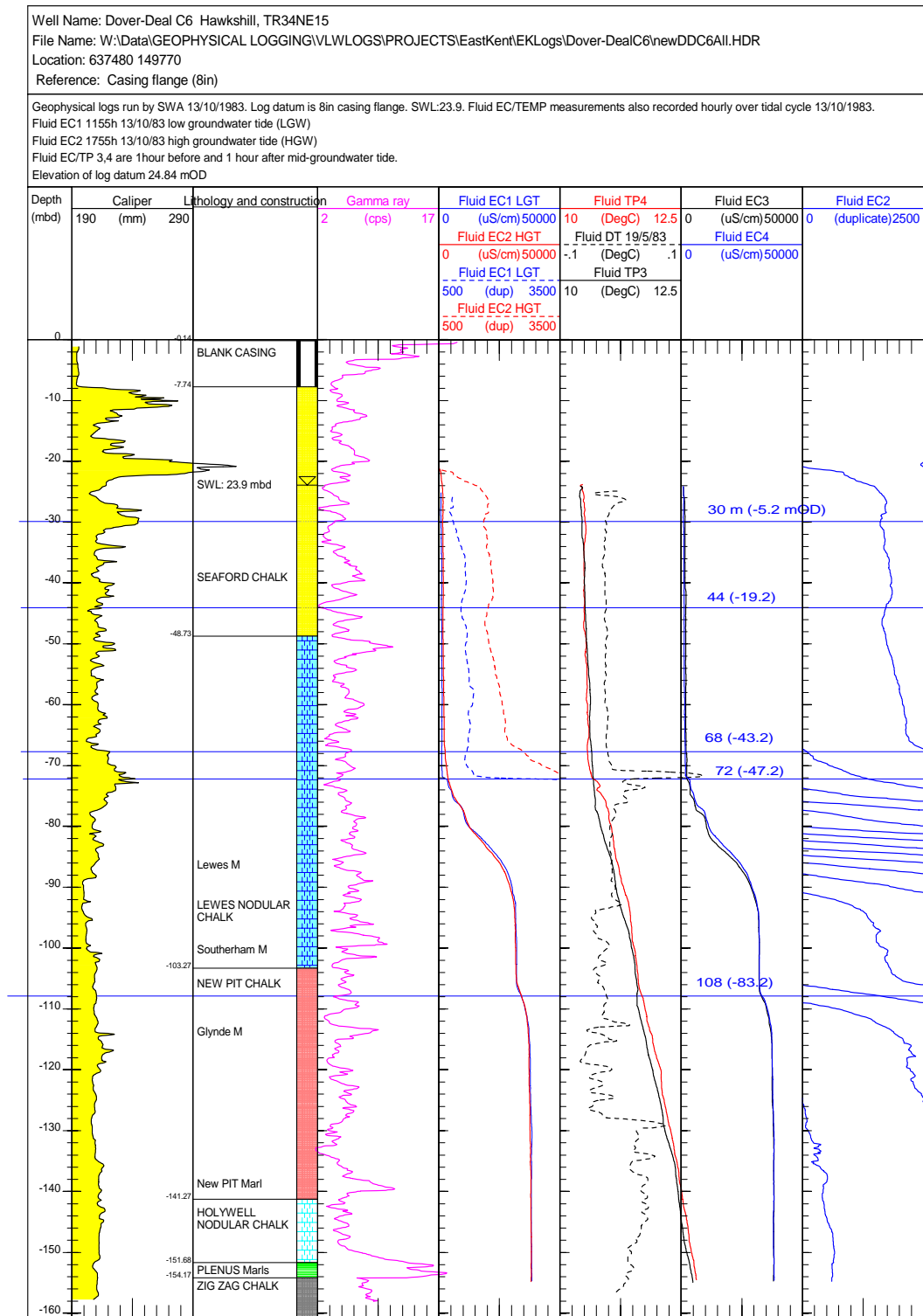

Figure 8-3 Geophysical logs showing wellbore flow of groundwater between fissured horizons and entry of brackish water, Dover-Deal borehole C6

Figure 21: Fluid logs showing upflow of groundwater from fissured horizons in Lewes Chalk to wellscreen opposite Seaford Chalk

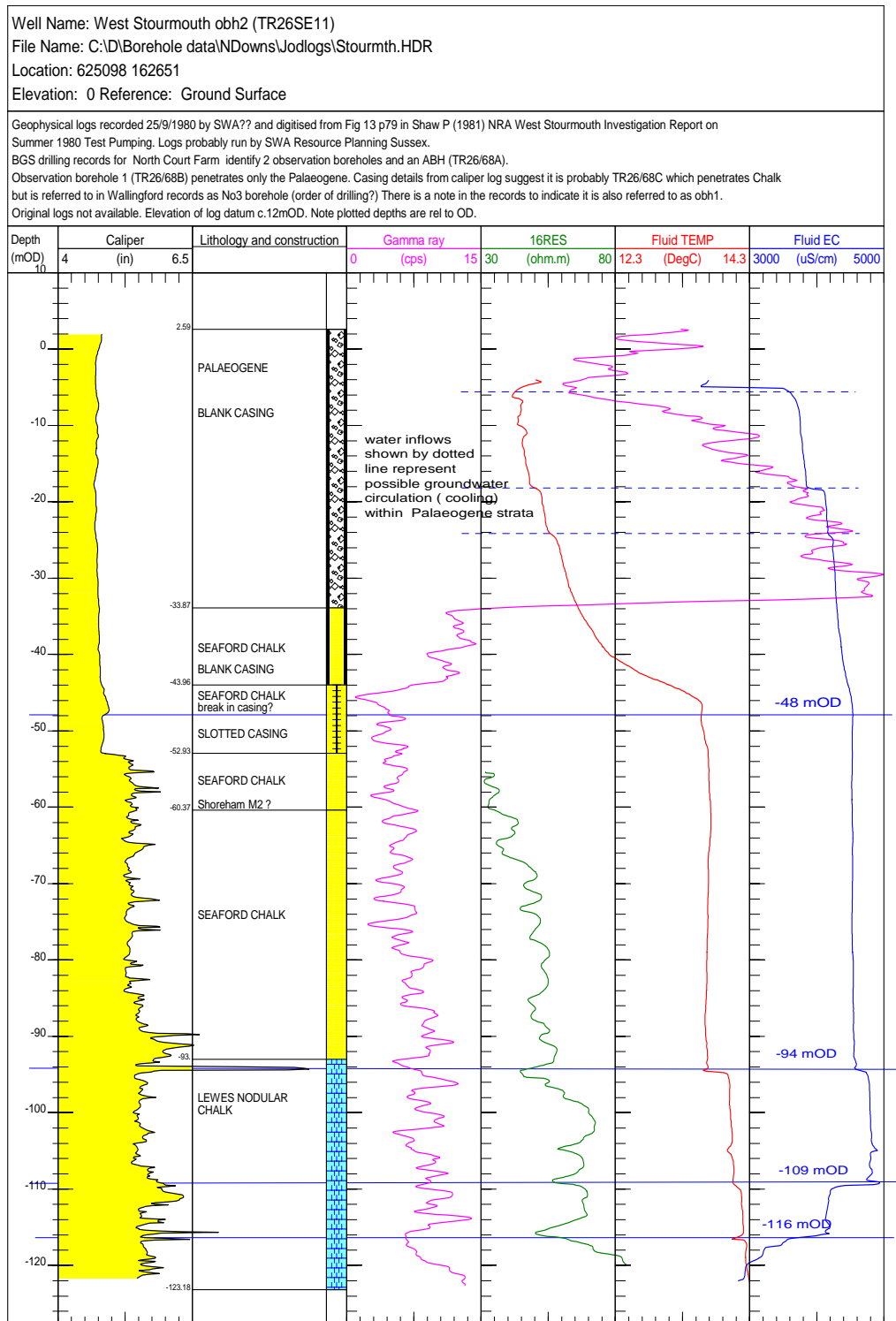

Figure 8-4 Fluid logs showing upflow of groundwater from fissured horizons in the Lewes Chalk to wellscreen opposite Seaford Chalk

Figure 22: Fluid log profile changes in a coastal borehole caused by changes in sea tide, Dover-Deal borehole C3

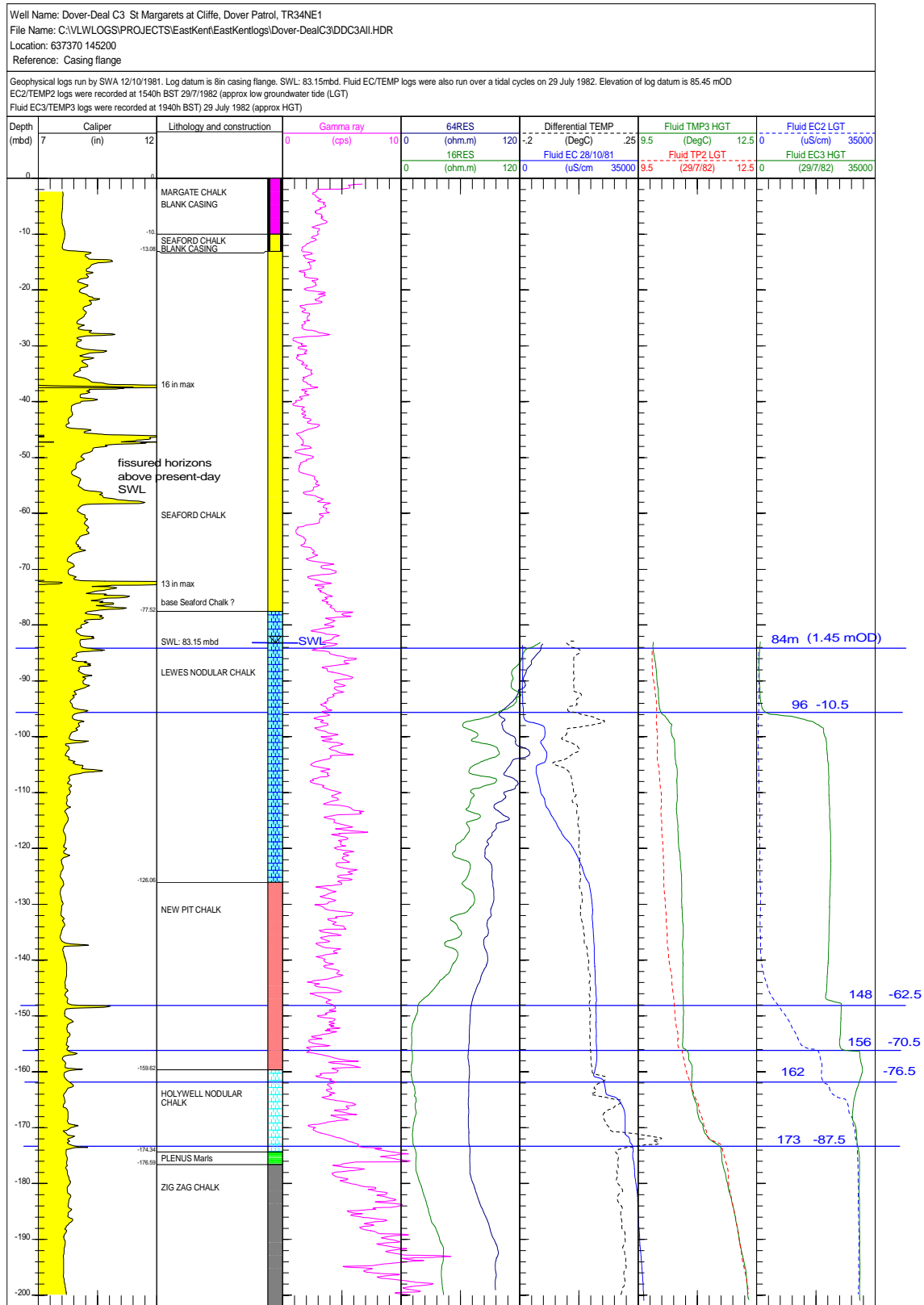

Figure 8-5 Fluid log profile changes in a coastal borehole caused by changes in sea tide, Dover-Deal bh C3.

Figure 23: Fluid logs recorded whilst pumping, Reculver borehole 1

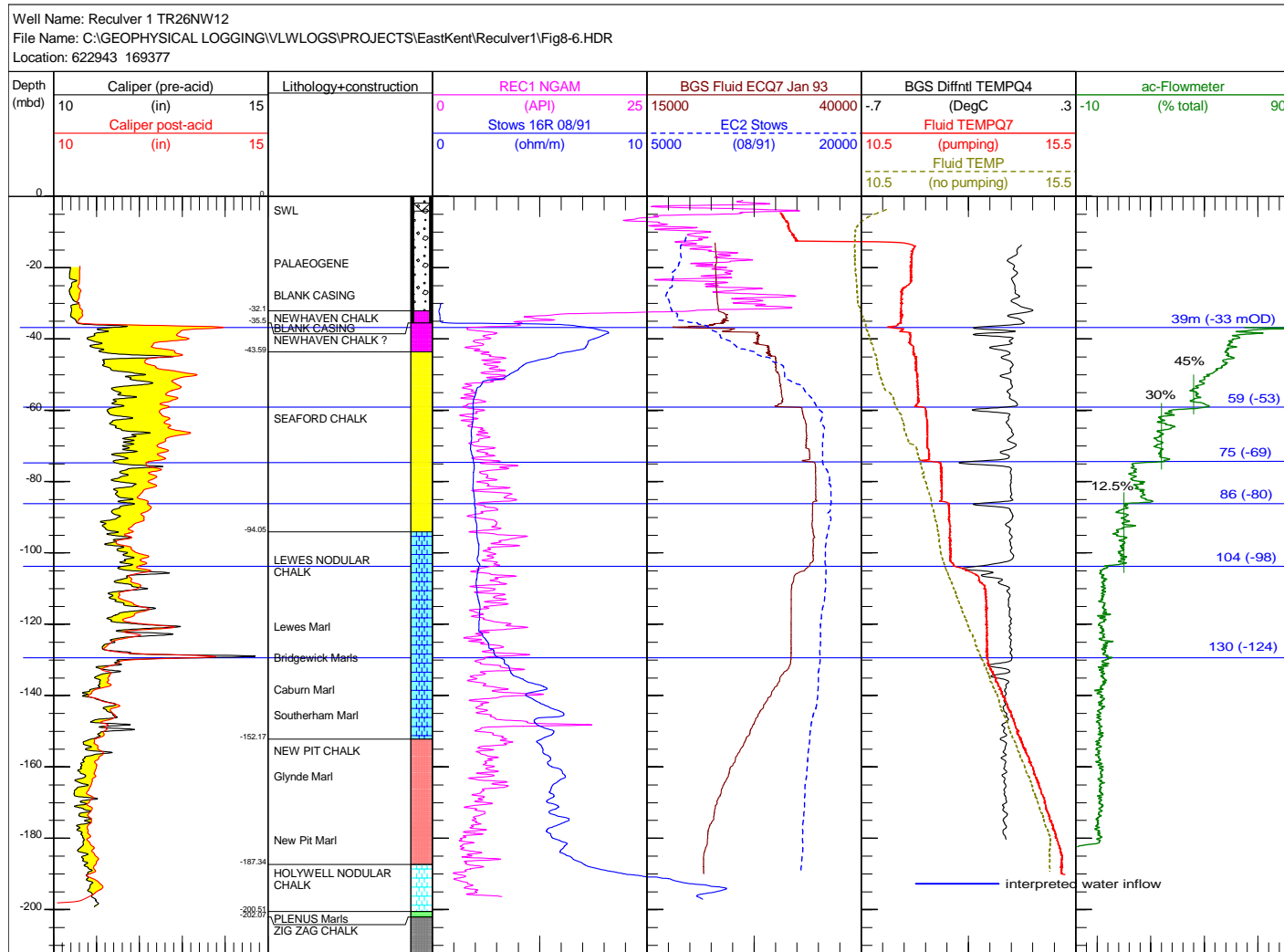

Figure 24: Comparison of flowmeter logging, matrix permeability and packer test bulk permeability measurements to characterise horizons of fluid movement within the Chalk aquifer (Totford borehole, Hampshire)

Totford BGS borehole

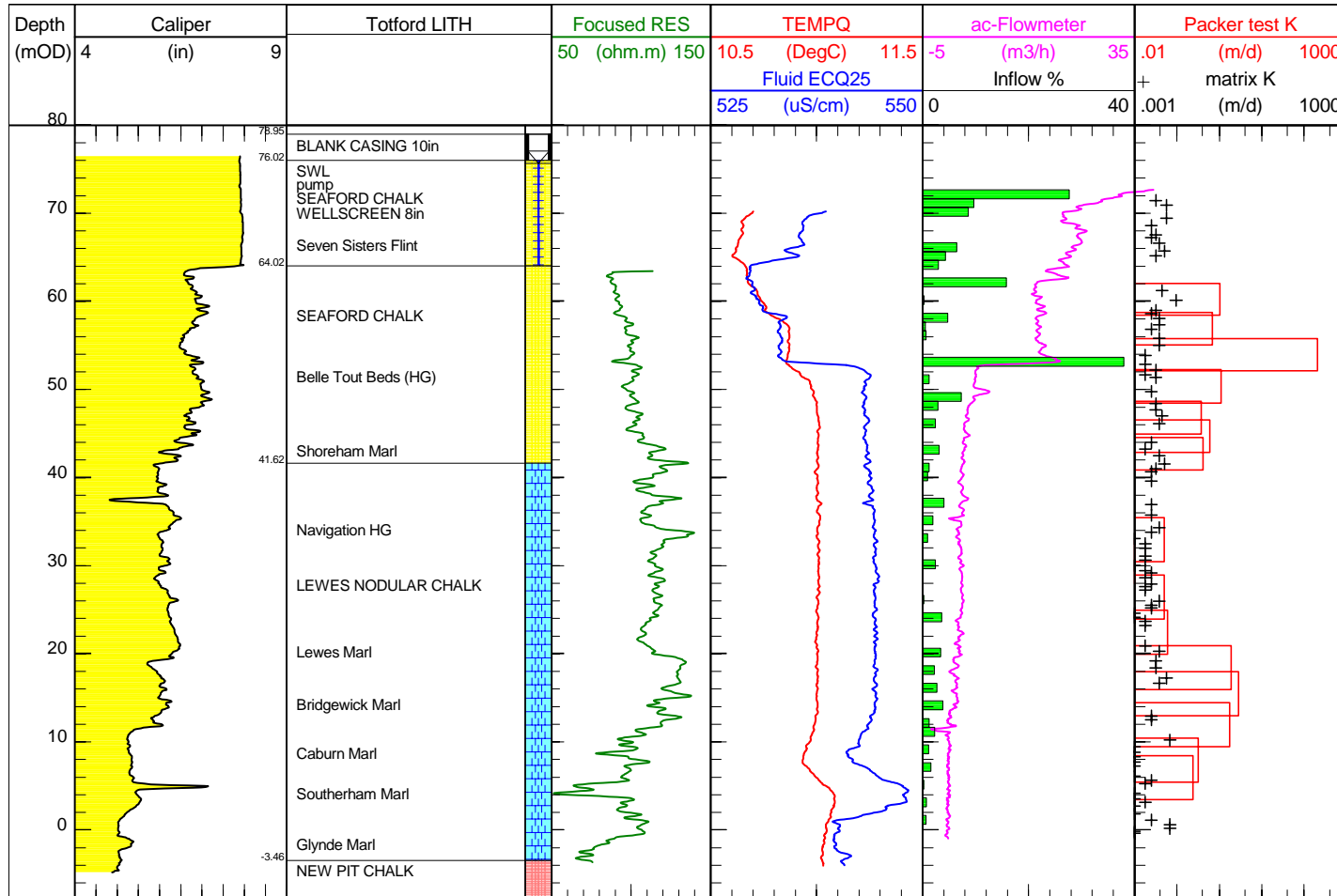

Figure 8.7 Comparison of flowmeter logging, matrix permeability and packer test bulk permeability measurements to characterise horizons of fluid movement within the Chalk aquifer (Totford borehole, Hampshire)

Figure 25: Scale cross-section SW-NE showing north-easterly dip of strata, shallower slope of water table and high fluid SEC in the Chalk aquifer from two sources

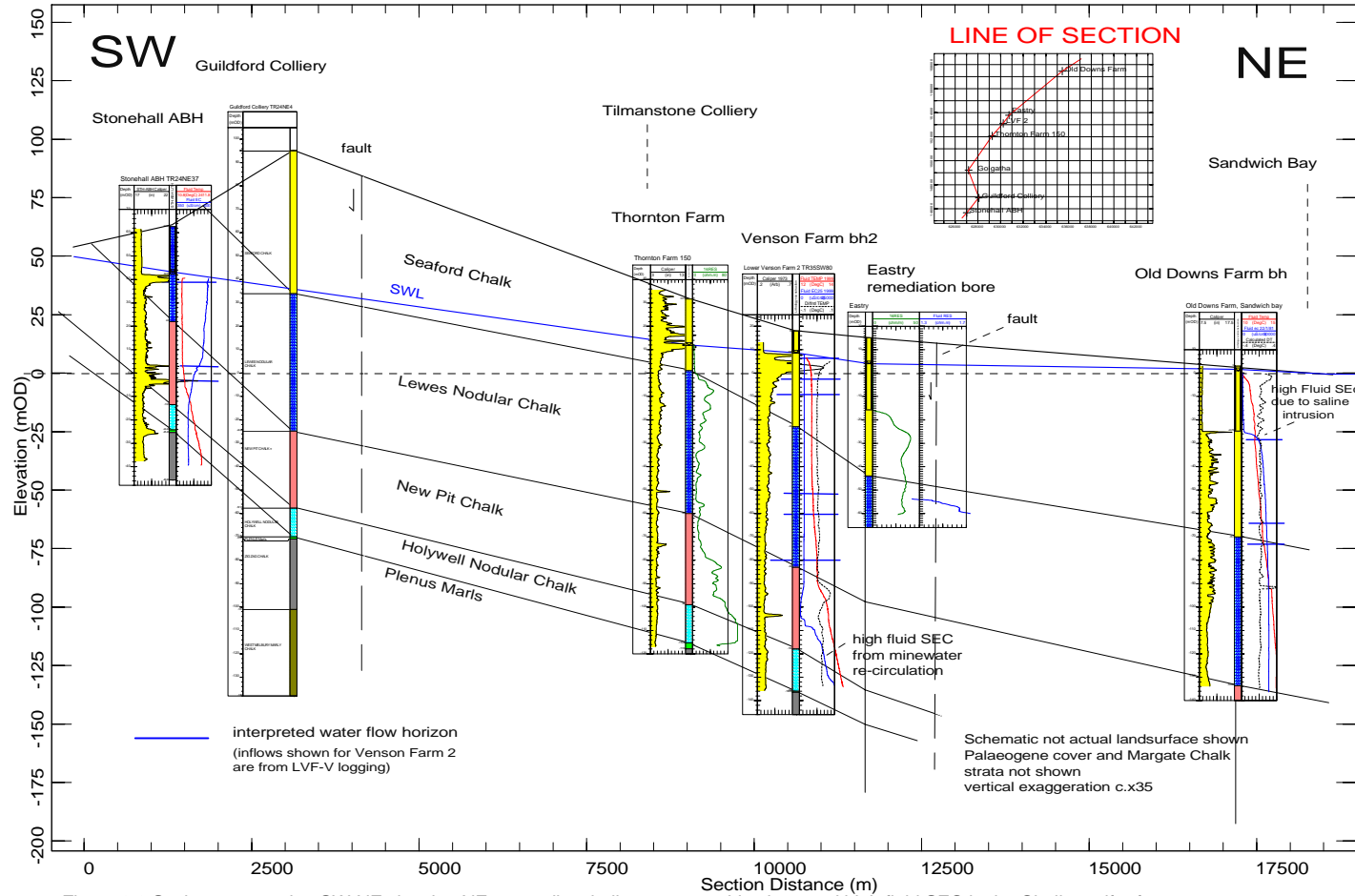

Figure 8.8 Scale cross-section SW-NE showing NE strata dip, shallower watertable slope and high fluid SEC in the Chalk aquifer from two sources.

Figure 26: Scale hydrogeological cross-section, Dover-Deal C2-C6, East Kent, based on geophysical logging data

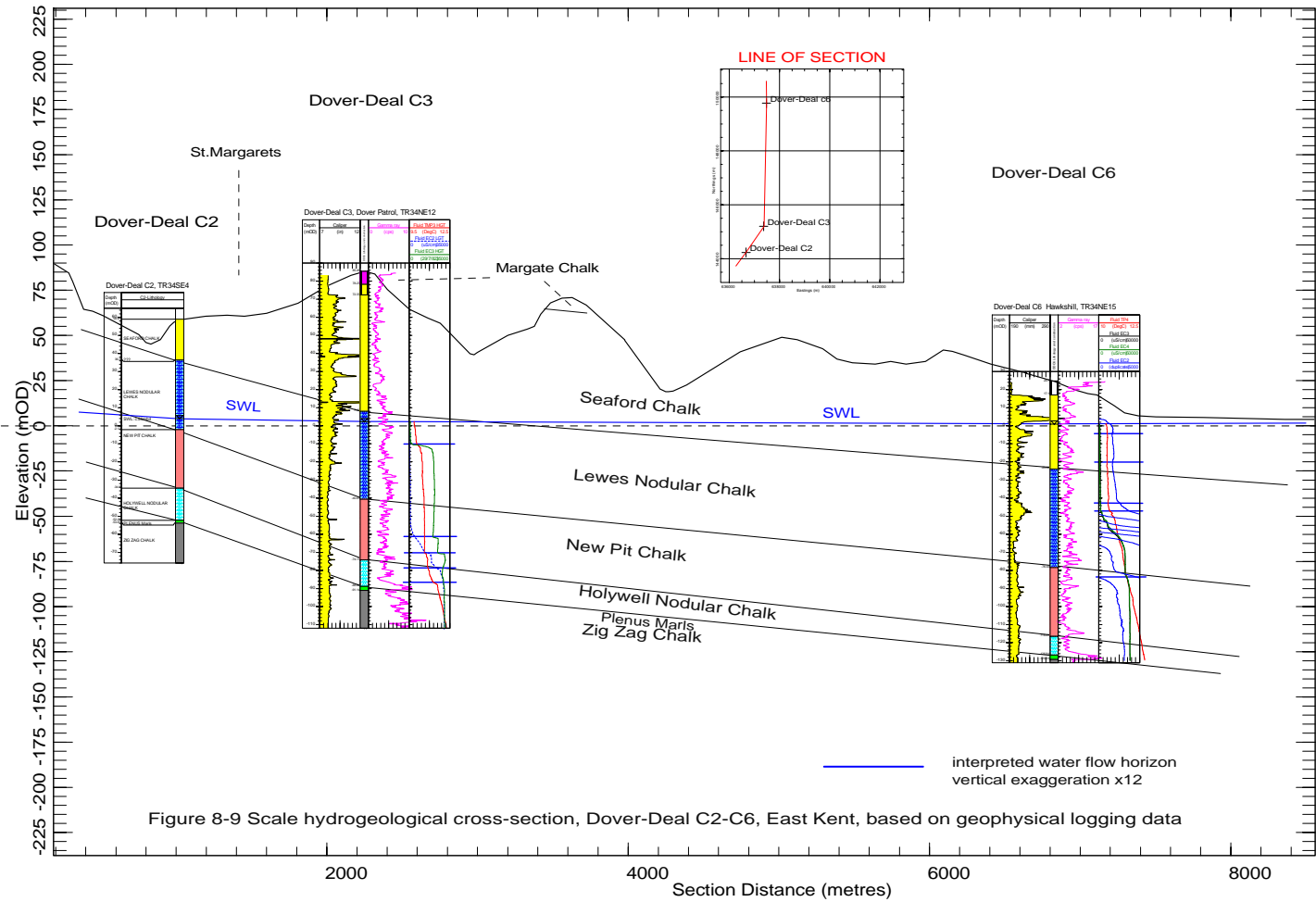

Figure 8-9 Scale hydrogeological cross-section, Dover-Deal C2-C6, East Kent, based on geophysical logging data

Figure 27: Scale hydrogeological cross-section Stodmarsh –Reculver, based on geophysical logging data

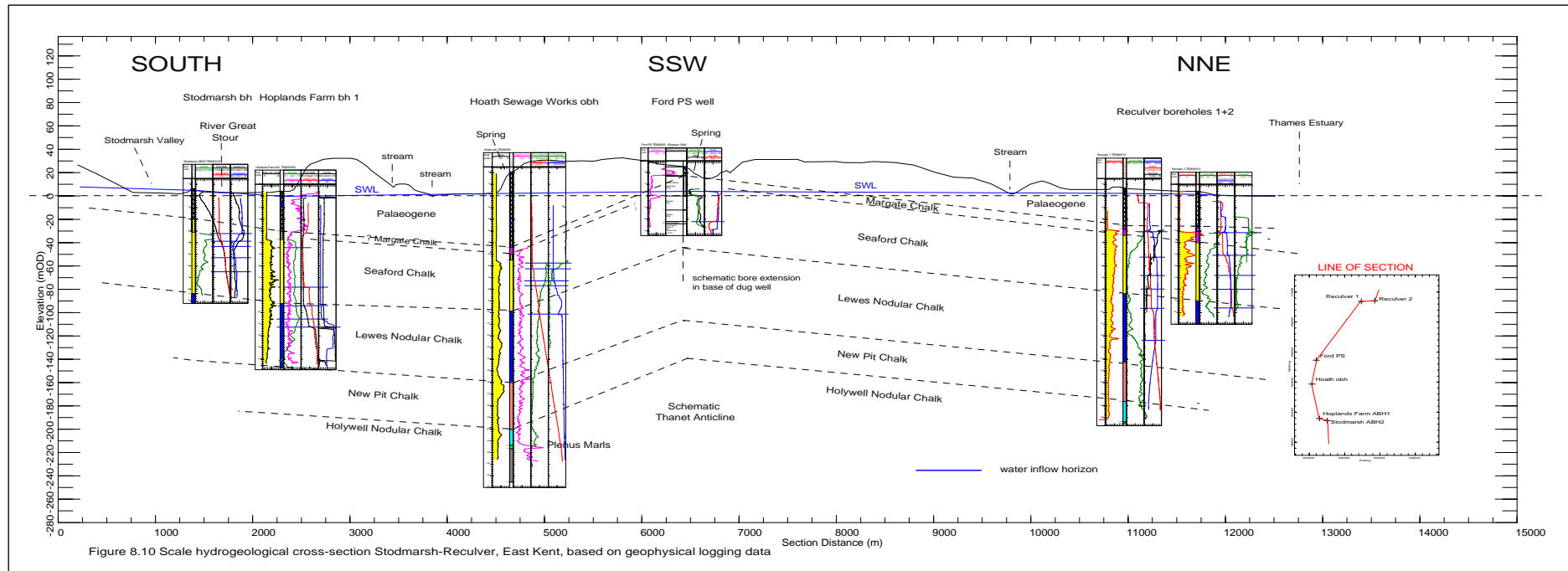

Figure 8.10 Scale hydrogeological cross-section Stodmarsh-Reculver, East Kent, based on geophysical logging data

Table 1: Correlation of biostratigraphical and lithostratigraphical classification schemes for the Chalk of southern England

Stage	Foraminiferal Zones*			Macrofossil		Traditional southern England subdivisions #	North Downs Robinson (1986)	South Downs Mortimore (1986)	Shaftesbury Bristow et al. (1995)	Southern England Bristow et al. (1997)	Southern England Rawson et al. (2001)			
	1980	UKB	BGS	Zones	Subzones									
Campanian (pars)	B3 (pars)	18 (pars)	21	<i>Belemnitella mucronata s.l. (pars)</i>		Upper Chalk	Ramsgate Chalk Formation	Portsdown Chalk Member	Spetisbury Ck	Studland Chalk	Portsdown Chalk Formation			
		17												
	B2	16	20	<i>Goniotentis quadrata</i>	'post <i>A. cretaceus</i> beds' <i>Applonocrius cretaceus</i> <i>Hagenowia blackmorei</i> 'abundant <i>O. pilula</i> ' <i>Echinocorys depressula</i>									
Santonian	B1	15	18	<i>Offaster pilula</i>		Upper Chalk	Margate Member	Newhaven Chalk Member	Blandford Chalk	Margate Chalk	Newhaven Chalk	Margate Chalk Member	Newhaven Chalk Formation	
				<i>Umtacrinus anglicus</i> <i>Marsupites testudinarius</i> <i>Umtacrinus socialis</i>										
Coniacian		14	17	<i>Micraster coranguinum</i>		Upper Chalk	Broadstairs Member	Seaford Chalk Member	Upper Chalk	Seaford Chalk	Seaford Chalk	Seaford Chalk Formation		
		13	16											
		12	15											
Turonian		11	13	<i>Micraster cortestudinarium</i>		Upper Chalk	St Margarets Member	Lewes Chalk Member	Lewes Chalk	Lewes Nodular Chalk	Lewes Nodular Chalk Formation			
		10	12	<i>Plesiocorys plana</i>										
		10	11	<i>Terebratulina lata</i>		Middle Chalk	Aycliff Member	New Pit Beds	New Pit Chalk	New Pit Chalk	New Pit Chalk Formation			
		9	9	<i>Mytiloides labiatus s.l.</i>										
Cenomanian	U	1977	8	<i>Neocardioceras juditi</i>		Middle Chalk	Dover Chalk Fm	Ranscombe Ck	Middle Chalk	Middle Chalk	Middle Chalk	Holywell Nodular Chalk	Holywell Nodular Chalk Formation	
		14	8	<i>Metioceras gestinianum</i>										
		15	7	<i>Calyoceras guerangeri</i>										
		12	6	<i>Acanthoceras jukesbrowni</i>										
		1111	5	<i>Acanthoceras rhotomagense</i>	<i>Turrilites acutus</i> <i>Turrilites costatus</i>									
	M		9 & 10	3 & 4	<i>Mantelliceras dixonii</i>		Lower Chalk	Earl Wear Bay Chalk Fm	Lower Chalk	Lower Chalk	Lower Chalk	Lower Chalk	West Melbury Chalk	West Melbury Marly Chalk
			8	2	<i>Mantelliceras saxbil</i> <i>Sharpetceras schlueteri</i> <i>Neostilingoceras carctianense</i>									
			7	1	<i>Mantelliceras mantelli</i>									
Upper Albian (pars)		6		<i>Stoliczkaia dispar</i> <i>Arraphoceras briacensis</i> <i>M. (D.) perinflatum</i> <i>M. (M.) rostratum</i>	Upper Greensand or Gault	Gault	Upper Greensand or Gault	UGS	Boyne Hollow Chert	Upper Greensand or Gault	Upper Greensand or Gault			

#Traditional Chalk subdivisions after Jukes-Browne and Hill (1903, 1904, for example). UGS = Upper Greensand; s.l. = *sensu lato*.
*Foraminiferal zones after Carter and Hart (1977), Swiecicki (1980), Hart et al. (1989) (UKB zones) and Wilkinson (2000) (BGS zones).

Not to scale

Table 2: Correlation of stratigraphic terminology: marker beds

Names in bold type are those preferred in this report.

Formation	Terms originating from Sussex	Terms originating from Kent and elsewhere
Seaford Chalk	Rough Brow Flint	Whitaker's Three-Inch Flint
	Seven Sisters Flint	East Cliff Semi-Tabular Flint (Gale & Smith) Oldstairs Bay Flint (Robinson)
	Baily's Hill Flint	Chartham Flint (Bailey)
	Belle Tout Marl	Hope Point Marl (Robinson)
	Shoreham Marl 2	East Cliff Marl 2 (Robinson)
Lewes Chalk	Lewes Marl	Cobbler Marl (Robinson)
	Navigation Marl	Ness Point Marl (Robinson)
	Light Point Hardground	(Lower) Corn Hill Hardgrounds (Robinson)
	Bridgewick Marl 2	Fan Bay Marl (Robinson)
	Caburn Marl	Crab Bay Marl (Robinson)
	Southerham Marl 2	Langdon Bay Marl 2? (Robinson)
New Pit Chalk	Glynde Marls	Maxton Marls (Robinson)
	New Pit Marl 1	Warren Marl 1 (Robinson)
	Malling Street Marl 1	Round Down Marl (Robinson)
	Gun Gardens Main Marl	Lulworth Marl (Gale)

Sources: (Mortimore, 1986a)

Sussex; (Gale and Smith, 1982; Bailey et al., 1983; Robinson, 1986; Gale, 1996)

Kent and elsewhere;

Table 3: Relative position of marker beds near the base of the Lewes Chalk in Kent

Interval thickness * (metres)	Marker beds (see Table 2)	Traditional subdivision	Robinson, 1986	Mortimore et al., 2001	This report
	Basal Complex	Upper Chalk	St Margarets Member	Lewes Nodular Chalk	Lewes Nodular Chalk
3 to 5					
	Caburn/Crab Bay Marl				
9.5				Lewes Nodular Chalk	
	Southerham Marls				
3.5					
8		Middle Chalk	Akers Steps Member		
	Lydden Spout Flint				
1.5					
1				New Pit Chalk	New Pit Chalk
	Glynde/Maxton Marl 4		Aycliff Member		
4.8					
	Glynde/Maxton Marl 2				

* Typical thickness of interval between marker beds at the Kent Coast.

Table 4: Valley lineaments; rose diagram statistics

STATISTICS	All domains	domain1	domain2	domain3a	domain3b	domain4	domain5	domain6
n	600	56	21	145	77	46	89	62
M	40.128	13.085	4.006	45.907	33.307	57.927	39.288	166.178
R	0.328	0.170	0.678	0.301	0.652	0.504	0.515	0.342
S _B	33.209	36.919	22.977	33.864	23.898	28.547	28.201	32.868
K	0.695	0.344	1.974	0.632	1.877	1.162	1.198	0.727
d° _{0.05}	4.788	NA	10.560	10.656	5.768	10.796	7.553	14.262
Peaks in azimuthal distribution		035	015	035	035	055	040	000
		105	050	075	085	135	085	085
		175	155	115			115	125
n	number		R	magnitude (length) of vector mean		K	strength of vector mean	
M	mean vector orientation		S _B	circular standard deviation		d° _{0.05}	confidence sector at 95% level	

Table 5: Summary of gamma ray and resistivity log measurement statistics for the Chalk units penetrated in selected boreholes in East Kent

Borehole	Interval (mbd)	Stratigraphy	Gamma ray (API)				Electrical resistivity (ohm.m)				Comments
			min	max	mean	SD	min	max	mean	SD	
Boughton ABH2	22-42	Seaford	2.0	6.6	3.59	0.90	62.5	76	69	4.4	16RES
	43-85	Lewes	2.17	7.17	3.77	0.85	58	100	84	8.3	
	86-125	New Pit	1.84	5.32	3.5	0.73	53	87	71.6	7.5*	*to 110m only
	126-138	Holywell	1.62	4.12	2.91	0.64	92	106	99.3	4.1	
Capel le Ferne W4	71-99	Zig Zag	13.32	48.92	25.6	7.12	45.2	78	63.8	9.8	
	100-134	WMMC	26.3	92.1	43.6	11.2	14.5	60.7	33.8	9.5	16RES
Hoath obh	76-119	Seaford	3.15	8.7	5.76	1.19	61.4	95.6	79.3	11.4	Focused RES
	119-180	Lewes	3.45	14.1	7.11	1.82	43.7	67.6	56.3	5.3	
	180-220	New Pit	3.39	9.24	5.91	1.27	30.7	39.9	35.9	2.35	
	220-234	Holywell	2.45	6.46	4.73	0.87	41.7	59.9	48.7	4.71	
	238-246+	Zig Zag	9.06	16.7	12.26	1.96	27.3	36.2	30.9	2.32	
Howfield Farm bh1	16-53	Lewes	1.8	7.5	3.7	0.85	20.5	69.3	59.1	8.50	16RES
	54-84	New Pit	1.38	6.6	4.0	0.97	54.6	87.9	67.3	7.64	
Reculver 1	35-94	Seaford	3.2	9.9	6.0	1.43	-	-	-	-	Resistivity log
	94-152	Lewes	3.64	18.6	6.9	1.95	-	-	-	-	affected by
	153-187	New Pit	3.11	9.13	5.6	1.35	-	-	-	-	high fluid
	187-200	Holywell	2.41	7.99	4.1	1.05	-	-	-	-	salinity

Table 6: Summary of water inflow positions interpreted from fluid log data of selected Chalk boreholes, East Kent Project

Borehole	BGS Registration number	Easting	Northing	SWL	Interpreted water inflows			Stratigraphy	Comment
					(mbd)	(mOD)	(mbSWL)		
Boughton ABH1	TR05NW30	604790	158770	13.28	18	7	4.72	Seaford Chalk	
					23	2	9.72	Seaford Chalk	
					30	-5	16.72	Seaford Chalk	
					58	-33	44.72	Lewes Chalk	
					72	-47	58.72	Lewes Chalk	
					94	-69	80.72	New Pit Chalk	
					104	-79	90.72	New Pit Chalk	
					118	-93	104.72	New Pit Chalk	
Boughton ABH2	TR05NW31	604610	158970	18.5	41	16	22.5	Lewes Chalk	
					64	-39	45.5	Lewes Chalk	
					81	-56	62.5	Lewes Chalk	
					96	-71	77.5	New Pit Chalk	
Buckland Paper Mill bh5	TR34SW123	630320	142970	c.4	16.5	1.5	12.5	New Pit Chalk	
					34	-31	30	Holywell Chalk	
					? 42	? -39	? 38	Holywell Chalk	
Capel le Ferne W4	TR23NW152	? 627000	? 141000	85.8	92	?	6.2	Zig Zag Chalk	
					107	?	21.2	West Melbury Chalk	
Chilham ABH3	TR05SE26	607770	153450	1.73	26	-3	24.3	New Pit Chalk	
					31	-8	29.3	New Pit Chalk	
Dover-Deal C3	TR34NE12	637370	145200	83.15	84	-2.3	0.8	Lewes Chalk	interpreted from saline intrusion effects
					96	-10.5	12.8	Lewes Chalk	
					148	-62.5	64.8	New Pit Chalk	

					156	-70.5	72.8	New Pit Chalk	
					162	-76.5	78.8	Holywell Chalk	
					173	-87.5	89.8	Holywell Chalk	
Dover-Deal C6	TR34NE15	637480	149770	23.9	30	-5.2	6.1	Seaford Chalk	interpreted from saline intrusion effects
					44	-19.2	20.1	Seaford Chalk	
					68	-43.2	44.1	Lewes Chalk	
					72	-47.2	48.1	Lewes Chalk	
					108	-83.2	84.1	New Pit Chalk	
Dover-Deal C8	TR34SE5	636670	144220	55.2	67	-8	11.8	undifferentiated	
					87	-28	31.8	undifferentiated	
					100	-41	44.8	undifferentiated	
					112	-53	56.8	undifferentiated	
					126	-67	70.8	undifferentiated	
Elms Vale Laundry bh2	Not registered	??	??	c. 15.5	23	6.5	7.5	not determined	
					24	5.5	8.5	not determined	
					29.5	0	14	not determined	
Ford PS, Simpson well	TR26NW5	620397	165458	18.94	nd	nd	nd	not determined	large diameter well with adits
Hoath obh	TR26SW6	620160	163870	18.82	78	-57.5	59.2	Seaford Chalk	inflows determined during pumping
					83	-62.5	64.2	Seaford Chalk	
					93	-72.5	74.2	Seaford Chalk	
					97	-76.5	78.2	Seaford Chalk	
					122	-	103.2	Lewes Chalk	
						101.5			
Howfield Farm ABH1	TR15NW54	611950	156200	3	31	-19	28	Lewes Chalk	
					34.2	-22.2	31	Lewes Chalk	

					? 58	?-46	? 55	Lewes Chalk	
					? 68	?-56	? 65	New Pit Chalk	
Howfield Farm ABH2	TR15NW55	611980	156300	2.45	26	-14	23.5	Lewes Chalk	
					45	-33	42.5	Lewes Chalk	
					56	-44	53.5	New Pit Chalk	
					? 64	?-52	? 61.5	New Pit Chalk	
					? 76	?-64	? 73.5	New Pit Chalk	
Kettle Hill Farm trial	Not registered	596580	155760	29.5	46	27	16.5	New Pit Chalk	
					78	-5	48.5	Holywell Chalk	
					81	-8	51.5	Holywell Chalk	
Lower Venson Farm LVF-V	TR35SW26	630240	153110	8.54	12	6	3.5	Seaford Chalk	inflows determined during pumping
					20	-2	11.5	Seaford Chalk	
					26	-8	17.5	Seaford Chalk	
					69	-51	60.5	Lewes Chalk	
					78	-60	69.5	Lewes Chalk	
					85	-79	76.5	Lewes Chalk	
Old Downs Farm, Sandwich	Not registered	635450	157480	1.94	32	-29	30	Seaford Chalk	
					68	-65	66	Seaford Chalk	
					76	-73	74	Lewes Chalk	
Ottinge well1 (NW)	TR14SE9	617230	142510	c.2.2	29	59.7	27	Zig Zag Chalk	
					40	48.7	38	Zig Zag Chalk	
Primrose PS bh1	TR34SW91	630560	142320	c.5.5	29	-9.2	23.5	not determined	
Primrose PS bh2	Not registered	630560	142320	c.9.8	21	0.7	11.2	not determined	

					29	-7	19.2	not determined	
Reculver 1	TR26NW12	622943	169377	5.72	39	-33	33.3	Margate Chalk	inflows determined during pumping
					59	-53	53.3	Seaford Chalk	
					74	-68	68.3	Seaford Chalk	
					86	-80	80.3	Seaford Chalk	
					104	-98	98.3	Lewes Chalk	
					130	-124	124.3	Lewes Chalk	
Reculver 2	TR26NW15	623707	169419	2.79	36	-32	33.2	Margate Chalk	inflows determined during pumping
					55	-51	52.2	Seaford Chalk	
					72	-68	69.2	Seaford Chalk	
					84	-80	81.2	Seaford Chalk	
					100	-96	97.2	Lewes Chalk	
St.Margarets PS bh2	TR34NE9	635590	145250	c.48	51	6	3	Lewes Chalk	
					60	-3	12	Lewes Chalk	
					69	-12	21	Lewes Chalk	
Stodmarsh ABH2	TR26SW25	621020	161430	1.54	38.5	-32	37	Seaford Chalk	inflows determined during pumping
					45	-39	43.5	Seaford Chalk	
					49.5	-43.5	48	Seaford Chalk	
					59	-53	57.5	Seaford Chalk	
					71	-65	69.5	Seaford Chalk	
Stonehall ABH	TR24NE37	626939	145673	19.42	24	38.5	4.6	Lewes Chalk	
					43	19.5	23.6	New Pit Chalk	
					60	2.5	40.6	New Pit Chalk	
					68	-5.5	48.6	New Pit Chalk	
Stonehall	TR24NE36	627020	145680	21.64	35	26	13.4	Lewes Chalk	

obh									
					52	9	30.4	New Pit Chalk	
					68	-7	46.4	New Pit Chalk	
					78	-17	56.4	Holywell Chalk	
West Stourmouth obh 2	TR26SE11	625098	162651	??	?	-48	??	Seaford Chalk	probable downward well bore flow 48-94 mbd
					?	-94	??	Lewes Chalk	
					?	-109	??	Lewes Chalk	
					?	-116	??	Lewes Chalk	

mbd: metres below (borehole) datum

mOD: metres relative to Ordnance Datum

mbSWL: metres below static (non-pumping) water level

Table 7: Depth to estimated base of more rapid groundwater circulation interpreted from fluid temperature log profiles in selected East Kent Chalk boreholes

Borehole	BGS Registration number	Estimated base of more rapid groundwater circulation			Comment
		(mbd)	(mOD)	(mbSWL)	
Boughton ABH1	TR05NW30	94	-69	80.7	
Boughton ABH2	TR05NW31	96	-71	77.5	
Buckland Paper Mill bh 5	TR34SW123	nd	nd	nd	
Capel le Ferne W4	TR23NW152	107	27	21.2	
Chilham PS bh3	TR05SE26	60	-37	58.3	
Dover-Deal C3	TR34NE12	173	-87.6	89.8	
Dover-Deal C6	TR34NE15	72	-47.2	48	Alternative interpretations
		108	-83.2	84	
Dover-Deal C8	TR34SE5	126	-66.8	71	
Elms Vale Laundry bh 2	Not registered	38	-8.5	22.5	
Ford PS Simpson well	TR26NW5	nd	nd	nd	
Hoath obh	TR26SW6	97	-76.5	78	
Hoplands Farm bh 1	TR26SW82	98	-94	93.5	
Howfield Farm 1	TR15NW54	58	-46	55	
Howfield Farm 2	TR15NW55	64	-52	61.5	
Kettle Hill Farm trial bh	Not registered	81	-8	51.5	
LVF-borehole 2	TR35SW80	66	-48	56.3	Alternative interpretations
		109	-91	99.3	
LVF-vertical bh	TR35SW26	78	-60	69.4	
LVF-inclined*	TR35SW27	68	-50	58.5	* TVD
Old Downs Farm	Not registered	76	-73	74.1	
Ottinge PS well 1	TR14SE9	>40	<48	>38	
Primrose PS bh 1	TR34SW91	>44	<24	>38	
Primrose PS bh 2	Not registered	nd	nd	nd	
Reculver 1	TR26NW12	104	-98	100	
Reculver 2	TR26NW15	100	-96	97	
St Margarets PS bh2	TR34NE9	69	-12	21	
Stodmarsh ABH2	TR26SW25	71	-65	69	
Stonehall ABH	TR24NE37	68	-5.5	48	
Stonehall obh	TR24NE36	nd	nd	nd	
West Stourmouth obh 2	TR26SE11	106	-94	88	
mean	87.5	-56.5	66.9		

LVF: Lower Venson Farm

TVD: true vertical depth

mbd: metres below (borehole) datum

mOD: metres relative to Ordnance Datum

mbSWL: metres below static (non-pumping) water level