

Stochastic Information Technology Modelling for Business Processes

Alan Edwin Serrano Rico

A Thesis Submitted for the Degree of Doctor of Philosophy

Department of Information Systems and Computing

Brunel University

June, 2002

Abstract

Business Processes (BP) and Information Technology (IT) are two areas that work very closely in helping organisations to keep or retain competitive advantage. Therefore, design in these areas should consider the advantages provided by, and the limitations that each of these domains imposes on each other. BP design tries to ensure that IT specifications are considered during the design of BP. Similarly, Information Systems (IS) design attempts to capture organisational needs, known as IS functional and Non-Functional Requirements (NFR), in order to meet the organisational goals. Despite this, BP and IT modelling techniques barely depict the way IT may affect BP performance or vice versa. For example, Business Process Simulation (BPS) is one of the modelling techniques that has been increasingly used to support process design. The performance measurements obtained from BPS models, though, are obtained considering only organisational issues, and thus cannot be used to assess the impact that IT may have on process performance. Similarly, IT modelling techniques do not provide IS performance measurements, and hence cannot depict the way IS may improve BP performance.

The relationship between BP and IT can be alternatively described in terms of the relationships between BP, IS and Computer Networks (CN). By looking at the parameters that govern these relationships a simulation framework was developed, namely ASSESS-IT, that develops simulation models that provide performance measurements of BP, IS and CN, and thus can reflect the impact that IT (IS and CN) may have on BP performance. This research uses a case study to test the proposed framework (theory testing), to understand the way BP, IS, and CN domains interact (discovery), and to propose alternative theories to solve the problems found (theory building).

The experimentation with the ASSESS-IT framework suggests that in order to portray the impact that IT may have on BP, analysts in these domains should first identify those performance specifications that describe how well the IS delivers its functionality (also known as non-functional requirements). It was found that when the IS does not depend on determined response time, the relationships between BP, IS and CN can be assessed using only the relationship between BP and IS. An alternative simulation framework, namely BPISS, is proposed to produce BPS models that provide performance measurements of BP and IS. Thus, BP and IT analysts can investigate the impact that a given IS design may have on BP performance, and identify a better BP and IS solution.

Acknowledgements

The completion of this work would not have been possible without the aid of a number of people and organisations that helped me to complete the journey that concludes with the submission of this thesis. Therefore I express my gratitude to:

- Julie Eatock and George M. Giaglis for their valuable contribution to this research.
- My friends David, Andres, Patrick, Zafeiris, Angelos, Nikos, Alkis, Nina, Kostas, Tally, Tomas, Randall, Mark, Chaitally, Emma, Olatz, Gila, and Elena because they provided me with moments of happiness that gave me the strengths to finish this journey.
- El Consejo Nacional de Ciencia y Tecnologia (CONACYT) de México, and all the members of this organisation that offered me the financial and moral support during my life as a student in this country.
- Brunel University's Department of Information Systems and Computing staff and friends that gently helped me with the quotidian tasks involved in this work.

And especially, I would like to thank Professor Ray J. Paul for his invaluable support as my tutor, supervisor and friend and to my family, Ariel Senior, Elvia, Ariel Junior, Azael and Monica because without their love I could not have been able to start and finish this dissertation.

Table of Contents

ABSTRACT	II
ACKNOWLEDGEMENTS.....	III
TABLE OF CONTENTS	IV
LIST OF FIGURES AND TABLES	VII
PREFACE	IX
DECLARATION	X
1. CHAPTER ONE: INTRODUCTION.....	1
1.1 INTRODUCTION.....	1
1.2 BUSINESS PROCESS AND INFORMATION TECHNOLOGY MODELLING	3
1.3 DISCRETE-EVENT SIMULATION VS STATIC MODELLING	4
1.4 RESEARCH OBJECTIVES	7
1.5 RESEARCH METHODS.....	8
1.6 DISSERTATION OUTLINE	9
1.7 CHAPTER ONE: SUMMARY AND CONCLUSIONS	11
2. INTEGRATION OF BUSINESS PROCESS AND INFORMATION TECHNOLOGY MODELS: THE ORGANISATIONAL CHALLENGE	13
2.1 INTRODUCTION.....	13
2.2 BUSINESS PROCESS CHANGE DESIGN.....	13
2.2.1 <i>A Critique of Business Process Change Design</i>	19
2.3 BUSINESS PROCESS MODELLING TECHNIQUES	20
2.3.1 <i>A Critique of Business Process Modelling</i>	21
2.4 INFORMATION SYSTEMS DESIGN	22
2.4.1 <i>Merise</i>	23
2.4.2 <i>Information Engineering</i>	25
2.4.3 <i>A Critique of Information Systems Design</i>	27
2.4.4 <i>Requirements Engineering</i>	28
2.5 INFORMATION TECHNOLOGY MODELLING TECHNIQUES.....	30
2.5.1 <i>Information Systems Modelling</i>	30
2.5.2 <i>Modelling Non-Functional Requirements.</i>	32

2.5.3	<i>Computer Network Modelling</i>	34
2.5.4	<i>A Critique of IT Modelling Techniques</i>	35
2.6	CHAPTER TWO: SUMMARY AND CONCLUSIONS.....	35
3.	MODELLING BUSINESS PROCESS AND INFORMATION TECHNOLOGY	39
3.1	INTRODUCTION.....	39
3.2	MODELLING PROCESS AND INFORMATION TECHNOLOGY USING DISCRETE-EVENT SIMULATION.....	39
3.3	BUSINESS PROCESS AND COMPUTER NETWORK SIMULATION INTEGRATION APPROACH	40
3.3.1	<i>BPS and CNS Integration Approach: The ASSESS-IT Framework</i>	41
3.4	THE CASE STUDY	46
3.4.1	<i>Background</i>	46
3.4.2	<i>Scope and Objectives of the Simulation Exercise</i>	47
3.5	APPLYING THE ASSESS-IT FRAMEWORK.....	48
3.5.1	<i>Phase one: BPS Model Development</i>	48
3.5.2	<i>Phase Two: CNS Model Development</i>	54
3.6	CHAPTER THREE: SUMMARY AND CONCLUSIONS.....	58
4.	BUSINESS PROCESS AND INFORMATION TECHNOLOGY MODELLING: PROBLEM REDISCOVERING.	60
4.1	INTRODUCTION.....	60
4.2	ASSESS-IT: COMPUTER NETWORK MODELLING REVIEW	61
4.2.1	<i>Computer Network Modelling Results</i>	63
4.2.2	<i>Computer Network Modelling Review: Conclusions</i>	65
4.3	ASSESS-IT: BUSINESS PROCESS MODELLING REVIEW.....	66
4.3.1	<i>To-Be Business Process Results</i>	68
4.3.2	<i>Business Process Modelling Review: Conclusions</i>	69
4.4	THE ASSESS-IT FRAMEWORK: LESSONS LEARNED.....	72
4.5	CHAPTER FOUR: SUMMARY AND CONCLUSIONS	74
5.	BUSINESS PROCESS AND INFORMATION SYSTEMS SIMULATION: RE- HYPOTHESIS	77
5.1	INTRODUCTION.....	77
5.2	THE BPISS FRAMEWORK	77
5.3	THE BPISS TIERS	78
5.3.1	<i>As-is BPS Model Development Guidelines</i>	78

5.3.2	<i>As-is BPISS Model Development Guidelines</i>	80
5.3.3	<i>To-be BPISS Model Development Guidelines</i>	86
5.4	CHAPTER FIVE: SUMMARY AND CONCLUSIONS	89
6.	MODELLING BUSINESS PROCESS AND INFORMATION SYSTEMS: THE BPISS FRAMEWORK ASSESSMENT	91
6.1	INTRODUCTION.....	91
6.2	APPLYING THE BPISS FRAMEWORK	91
6.2.1	<i>As-is BPS Model Development Description</i>	91
6.2.2	<i>As-is BPISS Model Development Description</i>	91
6.2.3	<i>To-be BPISS Model Development Description</i>	107
6.3	CHAPTER SIX: SUMMARY AND CONCLUSIONS.....	116
7.	SUMMARY AND CONCLUSIONS	119
7.1	INTRODUCTION.....	119
7.2	SUMMARY.....	119
7.2.1	<i>Background and Objectives</i>	120
7.2.2	<i>Modelling BP and IT Performance: A BP and IS Design Problem</i>	121
7.2.3	<i>Analysing the BP and IT Relationship: The ASSESS-IT Experience</i>	123
7.2.4	<i>Modelling BP and IS Behaviour: The BPISS Framework</i>	125
7.3	FINDINGS FROM THE RESEARCH.....	126
7.3.1	<i>The ASSESS-IT Framework Experience</i>	127
7.3.2	<i>The BPISS Framework Experience</i>	128
7.4	FURTHER RESEARCH.....	130
7.5	CRITICAL RE-EVALUATION.....	133
	REFERENCES	91

List of Figures and Tables

FIGURE 1 BUSINESS PROCESS/IT RELATIONSHIP	2
FIGURE 2 BP/IT MODELLING TECHNIQUES.....	7
FIGURE 3 A HIGH-LEVEL APPROACH TO PROCESS INNOVATION (DAVENPORT, 1993)	14
FIGURE 4 A STAGE-ACTIVITY FRAMEWORK FOR BUSINESS PROCESS REENGINEERING (KETTINGER ET AL., 1997).....	18
FIGURE 5 BPS AND CNS INTEGRATION (DERIVED FROM PAINTER ET AL., 1996).....	37
FIGURE 6 BUSINESS PROCESS AND COMPUTER NETWORK INTEGRATED SIMULATION APPROACH.....	41
FIGURE 7 ASSESS-IT SIMULATION FRAMEWORK	45
FIGURE 8. THE ORDER FULFILMENT PROCESS (OFP)	50
FIGURE 9. THE ORDER TAKING PROCESS (OTP).....	51
FIGURE 10. THE WAREHOUSE MANAGEMENT PROCESS (WMP).....	52
FIGURE 11. THE INVOICING PROCESS (IP)	53
FIGURE 12 CNS MODEL.....	55
FIGURE 13 APPLICATION SOURCE CLIENT SIDE.....	56
FIGURE 14 SERVER SOFTWARE APPLICATION	57
FIGURE 15 RECORD & FIELD ENTITIES/PROCESS RELATIONSHIP FROM AN IS PERSPECTIVE..	61
FIGURE 16 BP-IS-CN MODEL INTEGRATION	62
FIGURE 17 APPLICATION INSTANCE COMPLETION TIME WITH VARYING DEGREES OF NETWORK UTILISATION	64
FIGURE 18 DELIVERY TIMES SCENARIOS	70
FIGURE 19 TIERS IN THE BPISS FRAMEWORK	79
FIGURE 20 BP AND IS RELATIONSHIP.....	84
FIGURE 21 USE CASE DIAGRAM.....	94
FIGURE 22 ORDERING PROCESS ACTIVITY DIAGRAM.....	96
FIGURE 23 BACKORDERING PROCESS ACTIVITY DIAGRAM.....	96
FIGURE 24 REQUEST PRODUCT REPLENISHMENT ACTIVITY DIAGRAM	97
FIGURE 25 ORDERING COLLABORATION DIAGRAM.....	97
FIGURE 26 BACKORDERING COLLABORATION DIAGRAM.....	98
FIGURE 27 PRODUCT REPLENISHMENT COLLABORATION DIAGRAM	99
FIGURE 28 UPDATE INVENTORY COLLABORATION DIAGRAM.....	99
FIGURE 29 CLASS DIAGRAM	100
FIGURE 30 RECEIVE ORDER PROCESS.....	102
FIGURE 31 CHECK INVENTORY AND CREATE DISPATCH NOTES PROCESS (BPS MODEL).....	102

FIGURE 32 TO-BE BACKORDERING ACTIVITY DIAGRAM	108
FIGURE 33 TO-BE REQUEST PRODUCT REPLENISHMENT DIAGRAM.....	109
FIGURE 34 TO-BE BACKORDERING COLLABORATION DIAGRAM.....	110
FIGURE 35 TO-BE REQUEST PRODUCT REPLENISHMENT COLLABORATION DIAGRAM	110
FIGURE 36 CHECK INVENTORY AND CREATE DISPATCH NOTES PROCESS (BPISS MODEL) .	112
FIGURE 37 WAIT FOR WAREHOUSE REPLENISHMENT ACTIVITIES (ORIGINAL BPS)	112
FIGURE 38 WAIT FOR WAREHOUSE REPLENISHMENT ACTIVITIES (BPISS MODEL)	113
FIGURE 39 DAILY PRODUCT STOCK LEVEL REPORTED BY THE BPISS MODEL	115
TABLE 1 MODELLING GOALS AND REQUIREMENTS (ADAPTED FROM CURTIS ET AL 1992)	3
TABLE 2 DAVENPORT'S FRAMEWORK KEY ACTIVITIES (DAVENPORT, 1993)	16
TABLE 3 THE IMPACT OF IT ON PROCESS INNOVATION (DAVENPORT, 1993).....	19
TABLE 4 BP MODELLING TECHNIQUES VS PROCESS MODELLING PERSPECTIVES (ADAPTED FROM GIAGLIS, 1999)	22
TABLE 5 CLASSIFICATION OF MODELLING TECHNIQUES (ADAPTED FROM AVISON AND FITZGERALD, 1995)	32
TABLE 6 A REFER TABLE EXAMPLE.....	83
TABLE 7 FINAL REFER TABLE	103
TABLE 8 AS-IS BPISS AND ORIGINAL BPS MODEL RESULTS	106
TABLE 9 AS-IS BPISS AND ORIGINAL BPS MODEL RESULTS WITH CHANGES IN PRODUCT PROBABILITY	106
TABLE 10 ACTIVITIES AUTOMATED OR REPLACED IN THE BPISS MODEL	111
TABLE 11 BPISS MODEL RESULTS	113
TABLE 12 BPISS RESULTS WITH MINIMUM STOCK LEVEL OF 100 PRODUCTS	115

Preface

Dear Reader,

This dissertation is organised in seven chapters (you try any other number with a supervisor like mine). The first chapter sets the scene for the dissertation or is a roadmap to it. Chapter Seven concludes the dissertation by reminding the reader of where they have been. Chapter Two to Six are the research content.

Health Warning

Each chapter starts with a reminder where the reader is and where the dissertation is going. And each chapter ends with a reminder to the reader of where they have been and what is next. These opening and closing sections for each chapter can be readily missed out for readers with good memory.

Declaration

Some of the material contained in this dissertation has been disseminated as follows:

Reports

Some of the research presented in this dissertation was funded by a research grant as part of the Systems Engineering for Business Process Change (SEBPC) programme. The research quality was assessed as *tending to internationally leading* and is summarised in the following report.

Paul, R.J., O'Keefe, R. and Giaglis, G.M. (2000) *Final Report on EPSRC Grant. GR/M04969/01*, Brunel University, London.

Journals

Eatock, J., Paul, R.J., and Serrano, A. (2002) Developing a Theory to Explain the Insights Gained Concerning Information Systems and Business Process Behaviour: The ASSESS-IT project. *Information Systems Frontiers: A Journal of Research and Innovation*. (To be published)

Eatock, J., Paul, R.J. and Serrano, A. (2001) A Study of the Impact of Information Technology on Business Processes Using Discrete Event Simulation: A Reprise. *International Journal of Simulation Systems, Science & Technology*, 2 (2), pp.30-40.

Chapters in Edited Books

Eatock, J., Serrano, A., Giaglis, G.M., and Paul, R.J. (2002) Evaluating Information Technology: Lessons from Integrating Business Process Simulation with Computer Network Simulation. *In Systems Engineering for Business Process Change: New Directions* Henderson, P. (Ed.) Springer-Verlag, London, pp. 150-159.

Eatock, J., Giaglis, G.M., Paul, R.J., and Serrano, A. (2000) The Implications of Information Technology Infrastructure Capabilities for Business Process Change

Success. *In Systems Engineering for Business Process Change* Henderson, P. (Ed.) Springer-Verlag, London, pp. 127-137.

Conferences & Workshops

Eatock, J., Paul, R.J. and Serrano, A. (2002) Discrete Event Simulation for Information Technology and Process Performance Evaluation: A Case Study. Eldabi, T., Robinson, S., Taylor, S.J.E. and Wilcox, P.A. (Eds). *OR Simulation Study Group Workshop*, Horton Grange, Birmingham, 20-21 March. The Operational Research Society, pp.177-184.

Serrano, A., Eatock, J., and Macredie, R. (2000) Integration of Computer Network and Business Process Event Discrete Simulation Models Towards a Generic Reengineering Approach. Znati, T. and Simon, R. (Eds). *Proceedings of the Communications Networks and Distributed Systems Modelling and Simulation 2000 Western Multiconference*, San Diego, California, The Society for Computer Simulation International, pp. 113-118.

Giaglis, G.M., Paul, R.J., and Serrano, A. (1999) Reconciliation of Business and Systems Modelling Via Discrete Event Simulation. Farrington, P.A., Nembhard, H.B., Sturrock, D.T., and Evans, G.W. (Eds). *Proceedings of the 1999 Winter Simulation Conference*, Phoenix, Arizona, The Society for Computer Simulation International, pp. 1403-1409.

Eatock, J., Serrano, A., Giaglis, G.M., and Paul, R.J. (1999) A Case Study on Integrating Business and Network Simulation for Business Process Redesign. *Proceedings of the 4th UK Simulation Society Conference*, Cambridge, April. pp. 114-118.

Serrano, A., Giaglis, G.M. and Paul, R.J (1999) Technical Issues Related to Integrating Modelling of Business Processes, IS and Computer Networks. *Proceedings of the UK Academy for Information Systems 1999 Conference*, York 7-9 April, 407-415.

1. Chapter One: Introduction

1.1 Introduction

Considering that Business Process (BP) and Information Technology (IT) are two organisational areas that are closely related in practice, this research aims to provide a modelling framework that dynamically portrays the interactions between business processes and information technology to aid the understanding of the way this relationship operates.

The view that Business Process (BP) and Information Technology (IT) are closely related is not new and has been widely documented by professionals and academics. For example, Childe et al. (1994) state that the initiative to move towards Business Process Reengineering (BPR) in many cases originates from the IT departments. Similarly, Davenport and Short (1990) affirm that, when used together, Information Technology and Business Process Redesign have the potential to create a new type of industrial engineering. Rhodes (1998) supports the idea that IT must not be viewed just as a BP supporting tool, but as a management philosophy. Turban et al. (1996) assure that many organisations rely heavily on Information Systems (IS) to achieve their business goals and objectives and to gain or retain competitive advantage. Therefore, many BPR projects usually advocate the generation of new IT or propose changes to the existing one.

To design business processes that satisfy in the best possible way the organisational objectives, a number of design approaches have been proposed, most of them relying on a wide spectrum of modelling techniques. Many process approaches acknowledge that the use of a new IT infrastructure may influence the design of business processes and advocate the idea that the design of BP and IT should be coordinated. Despite this fact, the relationship between BP and IT is usually explored only in the very first stages of these approaches, providing little guidance of how this relationship could be modelled.

Similar circumstances are found in many IS design approaches. IS design approaches focus on the development of information systems. In doing so, they address organisational issues only in the early phases of the IS design process. Furthermore, modelling techniques used in the IS domain focus almost entirely on technical aspects of the IS.

This research assumes that the relationship between BP and IT can be seen as a three layered structure, namely Business Process, Information Systems and Computer

Networks (CN). Business processes usually rely on the support provided by the information systems to perform many of the activities. Similarly, the information systems that support these processes also depend on the underlying communications infrastructure, namely computer network (see Figure 1).

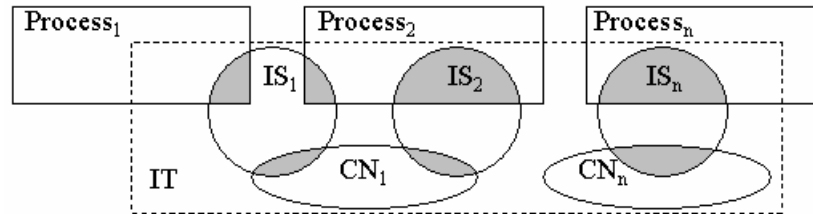

Figure 1 Business Process/IT Relationship

Figure 1 depicts the relationship between BP and IT domains. The rectangles represent the various processes that may be found in any organisation, the circles represent the information systems that support those processes and the ovals represent the computer network infrastructure. It can be seen that the organisation can have more than one process (Process₁, Process₂, ..., Process_n), more than one information system (IS₁, IS₂, ..., IS_n) and more than one computer network (CN₁, ..., CN_n). It can also be observed that one information system may support more than one process (this is the case for IS₁) and that one computer network may support more than one information system (this is the case for CN₁). The grey areas show the interactions between processes, information systems and computer networks. Figure 1 suggests that the relationship between these three domains is complex and that changes in any domain may have an impact on the others. Figure 1 also suggests that particular attention must be paid to the IS domain since it is the "connection" layer between the business processes and computer network layers. Because of this, changes to the business process may have a direct impact on the IS, affecting indirectly the CN infrastructure. Likewise, changes to the computer network infrastructure may have a direct impact on the IS, affecting indirectly the BP layer. Finally, changes to the IS may have an impact on both the BP and CN layers. Thus, BP, IS, and CN may be viewed in terms of two relationships, namely BP-IS and IS-CN, which are related by the IS layer. Recognising the complexity of these relationships creates difficulties in assessing the impact that changes to any of these domains may have to the others before implementing them. It is known that modelling techniques are used in both BP and IT domains to aid the design of BP, IS and CN. The following section provides a discussion of the fundamental principles of modelling, briefly outlining current modelling techniques used in the BP, IS and CN domains and stating their advantages and limitations to address the relationships between them.

1.2 Business Process and Information Technology Modelling

In its very basic definition, a model is an abstract representation of a phenomenon and can be used to predict, observe, and diagnose the behaviour of the phenomenon in order to forecast the impacts of changes over the event that is being observed (Curtis et al., 1992). Because a model is an abstract representation of the real world the modeller's personal view will influence the model design as well as its final objectives. This in turn will necessarily impact upon the uses to which a model will be put and influence the requirements posed on the process techniques to be employed (Liles and Presley, 1996). Table 1 illustrates typical process modelling goals and objectives, along with associated requirements for modelling techniques in each case (Curtis et al., 1992).

Modelling Goals and Objectives	Requirements for Modelling Techniques
<i>Facilitate Human Understanding and Communication</i>	Comprehensibility, Communicability
<i>Support Process Improvement</i>	Model Process Components, Reusability, Measurability, Comparability, Support Technology Selection and Incorporation, Support Process Evolution
<i>Support Process Management</i>	Support Reasoning, Forecasting, Measurement, Monitoring, Management, and Co-ordination
<i>Automated Guidance in Performing Process</i>	Integrate with development environments, Support for Process Documentation, Reusability
<i>Automated Execution Support</i>	Automate Process Tasks, Support Co-operative Work, Automate Performance Measurement, Check Process Integrity

Table 1 Modelling Goals and Requirements (adapted from Curtis et al 1992)

According to the modelling goals and objectives presented in Table 1, a model must be able to provide a number of information elements to its users. Such elements include, for example, what activities comprise the process, who or what performs these activities, when and where these activities are performed, how and why they are executed, and what data elements they manipulate. Modelling techniques differ in the extent to which they highlight the information that answers these questions. Following there is a brief discussion of the modelling techniques used to assist BP and IT design, focusing on the way different techniques highlight different information.

Business Process Modelling techniques have been widely used to assist the understanding of the organisation. Business Process techniques identify the organisational processes and how they traverse different organisational areas using broad models of the way the organisation operates (Hammer and Champy, 1993). This can be done in order to give an understanding of possible scenarios for improvement (Ould, 1995). Flowcharting, IDEF0, IDEF3, Petri Nets, System Dynamics, Knowledge-based

Techniques, Role Activity Diagrams, Activity Based Costing, and Business Process Simulation (BPS) are some examples of the BP modelling techniques widely used in the organisational domain.

IT modelling techniques may differ from each other according to the IT area that is selected for study. On the IS side, Rich Pictures, Conceptual models, Data Flow Diagrams, Entity Relationship Diagrams, State-Transition Diagrams, IDEF1x, and Object-Oriented appear to be the most dominant modelling techniques. These techniques mainly focus on understanding what activities are being performed, where and/or by whom activities are performed and to understand the structure of the information produced or manipulated by a process and their relationships.

In the CN arena, Analytic Modelling and discrete-event simulation of Computer Networks, also named Computer Network Simulation (CNS), are the most significant modelling techniques. As with the BP domain, CN simulation techniques are widely used since they provide a friendly user environment. CN modelling techniques differ from those in the IS domain in that they focus on analysing the behaviour of the systems in terms of the data itself, rather than the information that it conveys. In terms of data communications, the information produced or manipulated by the system (data) is represented by a number of entities (bytes or packets) transmitted over a communication line. This is meaningless information when developing IS models. Although information and data are context dependent, it can be observed that modelling techniques applied to IS and CN differ from each other.

The fact that all three domains rely on a large number of modelling techniques, each addressing different aspects of BP, IS and CN, complicates the selection of the most appropriate technique or group of techniques that can help to depict the interactions between these three domains. This research examines the idea that discrete-event simulation is one of the most appropriate techniques to address this problem. The following section provides more information to support this argument. It distinguishes between static and dynamic modelling techniques. It also discusses the rationale behind simulation and highlights the advantages that simulation has over other modelling techniques, particularly over static modelling techniques, to address the interactions between BP and IT.

1.3 Discrete-Event Simulation Vs Static Modelling

One modelling technique that is found in both BP and IT domains is discrete-event simulation. There is, however, some variation in opinion as to what simulation actually is

(Paul and Balmer, 1993). Dorant and Gilbert (1994) offer one of the most simplistic ways of defining simulation by illustrating the basic idea behind it. They argue that after we have located or constructed a model of some target of interest to us, we wish to know the behaviour of the model. To achieve this we proceed to set the model running, probably in special conditions previously selected, and observe what the model does. So if the model is a computational process in a computer, then is a matter of executing that process. This, in their view, is what is called computer simulation.

Because there are many tools to develop simulation models and because these tools use different approaches, Law and Kelton (2000), have proposed to differentiate simulation into three major dimensions:

1. **Static vs. Dynamic Simulation Models.** A static simulation model is a representation of a system at a determined point of time or when time simply plays no role. Monte Carlo models provide examples of these kinds of methods. A dynamic simulation model, however, aims to represent a system as it evolves over time.
2. **Deterministic vs. Stochastic Simulation Models.** When a simulation model does not involve the use of any probabilistic components, for example, a chemical reaction represented by a complex set of differential equations, it is called a deterministic model. Nevertheless, many systems need to be modelled with some random input components and these give rise to stochastic models.
3. **Continuous vs. Discrete Simulation Models.** Continuous and discrete simulation models are defined analogously to the way discrete and continuous systems are defined. A discrete system is one for which the state variables change instantaneously at separated points in time. A continuous system is one for which the state variables change continuously with respect to time.

The fact that discrete-event simulation is considered within Law and Kelton's dynamic dimension posits this technique as one of the most suitable tools to model the interactions between BP, IS, and CN. For instance, the system under analysis in this research can be viewed as three interrelated subsystems, namely BP, IS and CN. The very complexity of the relationships in these subsystems indicates that is likely that static models cannot provide enough information to predict the impact that changes to any of these systems may have on the others. Dynamic models, however, enable the study of, and experimentation with, the internal interactions of a complex system or a subsystem within a complex one (Naylor et al. 1966, Banks et al. 2000, Law and Kelton, 2000).

Furthermore, there is some evidence that DES models have already been used, with some success, to model either business process or information technology. For example, Hlupic and Robinson (1998) advocate that DES enables a better understanding of organisational processes. They argue that one of the major advantages of DES over BP static modelling techniques is that DES enables the experimentation of different scenarios before implementing them, reducing in this way the risk of making wrong decisions. Conversely, static models are deterministic and do not enable evaluation of alternative re-designed processes.

Discrete-event simulation has also been widely employed in the IT domain, but mostly in the CN arena. The design of computer networks has become more complex and so analytic models are no longer valuable tools to design and validate large networks systems. Therefore, Computer Network Simulation (CNS) tools are being increasingly used to assist designers in modelling complex network systems (Sauer and MacNair, 1983, Williams, 1999). The advantages of these tools are discussed in Chapter Two.

Nevertheless, while this evidence shows that DES techniques are used in BP or IT domains, there is not much information about how to apply DES to address the interaction between BP and IT. The fact that BP and CN domains have already used DES techniques to depict the dynamic behaviour of process and computer networks suggests that this technique can also be used to model the interactions between BP, IS and CN. To achieve this, however, a number of problems have to be overcome. First, it is necessary to identify the major factors that govern the relationships between BP, IS and CN; in particular, the relationship between business process and information systems and subsequently the relationship between information systems and computer networks. Second, considering that the system under study is formed by a complex net of interactions (BP, IS and CN) it should be analysed in such a way that its dynamic behaviour is exhibited fully. The problem with this situation, however, is that there is little evidence of the use of dynamic modelling techniques for the IS domain.

Figure 2 groups modelling techniques into process and IT, which are subsequently divided into dynamic and static modelling. It can be observed that discrete-event simulation is used in the IT domain, namely CNS, and in the process domain (BPS). The IS domain, however, rely mainly on static techniques and does not use DES nor any other dynamic modelling techniques.

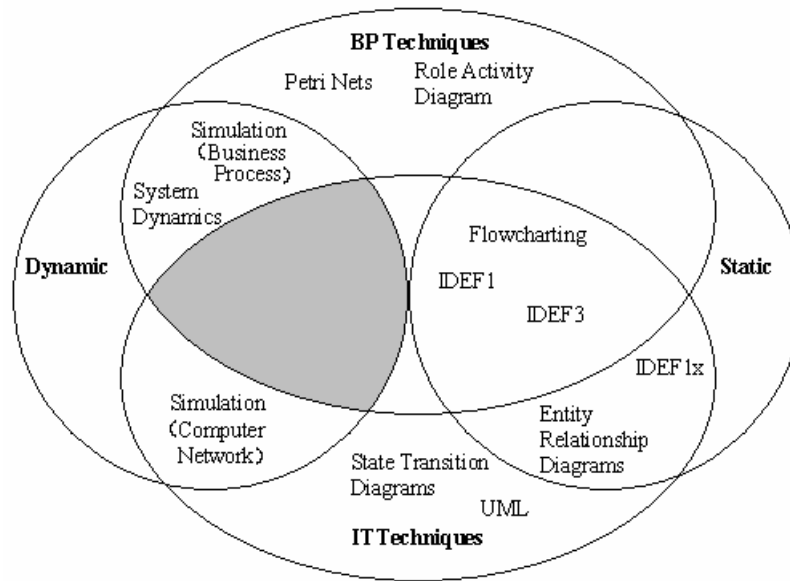

Figure 2 BP/IT Modelling Techniques

This research advocates the idea that a simulation framework that combines BPS, IS and CNS techniques can be developed in order to portray the interactions between these three domains and help on the understanding of the impact that changes to one of these domains may have to the others. The following section describes the objectives of this research in the attempt to propose the aforementioned framework.

1.4 Research Objectives

This research is based on the fact that BP and IT are two domains that interact in practice and therefore the design of BP or IT should be conducted considering the effects that one domain may have on the other. The research aims to provide a modelling framework to assess the interpenetrative relationship between BP and IT. A number of objectives need to be addressed in order to achieve this. They may be described as follows:

1. *Render evidence that current BP and IS design approaches and BP and IT modelling techniques do not provide clear guidance of how to assess the impact that changes to IT may have on the business processes and vice versa.* To achieve this goal, a literature review will analyse two BP and two IS design approaches that claim to address the BP and IT relationship highlighting their advantages and limitations to address this problem. Furthermore, the literature review also analyses current modelling techniques that are available in both domains trying to identify their strengths and weaknesses to model the interactions between BP and IT domains.

2. *Identify the parameters that govern the relationship between Business Processes, Information Systems, and Computer Networks.* In order to suggest modelling mechanisms to portray the relationship between BP and IT, it is necessary to understand which are the parameters that govern this relationship, in particular, the relationships between BP and IS and between IS and CN. To achieve this aim, the literature review will also analyse the IS factors that are more likely to affect BP and CN behaviour.
3. *Propose a simulation framework to portray the interactions between BP, IS, and CN.* Identifying the IS factors that may affect BP and CN design will also contribute to propose a modelling framework that depicts the relationships between these three domains.
4. *Test the framework.* It is important to test the modelling framework in order to assess if it can be used to depict the behaviour of BP, IS and CN. This objective will also help on identifying any weaknesses of the framework and proposing possible solutions to overcome them.
5. *Refinement of the framework.* Testing the framework will help to identify its weaknesses and to propose the corresponding refinements to eliminate or minimise them.
6. *Appraisal of the results.* An appraisal of both the framework and the refined framework will be performed in order to assess their suitability to accomplish the main objective of this research which is to depict the impact that changes to Information Technology may have on the Business Processes.

The major objective of this research is to develop a modelling framework that uses discrete-event simulation techniques to help BP and IT practitioners to model the interactions between Business Processes, Information Systems, and Computer Networks. It is expected, however, that this research will also contribute to identify deficiencies in these modelling domains and highlight the relevance to investigate this relationships in more detail as well as other possible ways to model them.

1.5 Research Methods

Galliers (1991) has classified research methods into scientific and interpretivist. The scientific approach assumes that the phenomena under consideration can be observed objectively and rigorously and that good research can be assessed by repeatability,

reductionism, and refutability (Checkland, 1981). The interpretivist approach argues that where people are involved, the methods proposed by natural science can be inappropriate because different stakeholders can view the same phenomena in different ways. These two ways of classifying research methods have led to a situation where supporters of the natural science approach may reject interpretivist methods arguing that the latter lack rigour and generalisability. Supporters of interpretivist approaches consider scientific methods as inappropriate to investigate human systems.

This dissertation attempts to investigate the relationship between IT and BP and to provide modelling mechanisms that help practitioners to depict the dynamic interactions between these two domains. Therefore, a research strategy that reflects the relative objectivity of the technical artefacts, namely IT, and the subjectivity of the social/organisational issues, namely BP, could be one that combines both scientific and interpretivist views (Braa and Vidgen, 1995). One such research strategy that meets these demands is a case study (Irani et al., 1999). A case study research strategy is one that uses systemised way of observing (Weick, 1984). A case study method has the flexibility not to require explicit control or to manipulate variables, to study a phenomena in its natural context, and to use qualitative tools and techniques for data collection and analysis (Yin ,1994). This suggests that this particular method may be appropriate for the research proposed in this dissertation.

A case study strategy can be differentiated by the objectives it aims to accomplish. The most common are discovery and theory building (Benbasat et al., 1988), theory testing (Lee, 1989), and discovery, building and testing (Irani et al., 1999).

For this research, a single case study approach is employed for discovery, building and testing. The case study is used to confirm or reject the hypothesis that a modelling framework that uses BPS and CNS can be used to depict the interactions between BP, IS and CN (theory testing). One of the advantages of using a single case study is that concentrating upon the same case study permits a full and rich understanding of the phenomena (discovery). This new knowledge will help reflection about the hypothesis proposed and to develop refinements or replacements of the modelling framework (theory building).

1.6 Dissertation Outline

This section presents an outline of the remaining six chapters along with a brief summary of their contents.

Chapter Two reviews two process-based approaches that claim to address the integration of process and IT design. Chapter Two concentrates on analysing one of the most popular approaches namely Business Process Reengineering (BPR) and specifically on two renowned BPR methodologies, those of Davenport (1993) and Kettinger et al. (1997). Different process modelling techniques are briefly analysed highlighting their advantages and limitations in relation to BP and IT modelling integration. The way the IT domain attempts to bridge process and IS design is investigated and two representative methodologies are selected and analysed: Merise and Information Engineering (IE). In order to investigate the ways the IT community models process and information systems, the most popular modelling techniques are reviewed and a comparison is made with those found in the BP domain. The chapter concludes with an analysis and discussion of the advantages and limitations of a framework for integrating business processes and information technology models.

Chapter Three develops a modelling approach that aims to combine business process and information technology modelling techniques to portray the interactions between process and IT. The approach is tested using a case study. To accomplish this task, Chapter Three is divided into six sections. Section 3.1 is an introduction to the contents of this chapter. Section 3.2 reviews business process discrete-event simulation, also called Business Process Simulation (BPS) and offers support for the notion that BPS is one of the most suitable process change techniques. It underlines the need for a modelling approach that aims to bridge the domains of BP and IT and which should maintain the same modelling features as those of BPS. Section 3.3 proposes a simulation framework, namely ASSESS-IT, that uses business process and computer network simulation techniques to explore the impact that IT may have on BP. Section 3.4 is an introduction to the case study to test the ASSESS-IT framework. It describes the case study background, the scope and objectives of the case study, the problem identification, and finally, describes in detail the *as-is* business processes. Section 3.5 describes the application process of the ASSESS-IT framework to the case study. A summary of this chapter and conclusions are described in section 3.6.

Chapter Four reviews both the process of the development of the simulation models and their results. Section 4.2 reviews the computer network simulation process and results and section 4.3 does the same for the business process models. Section 4.4 presents a critical appraisal of the ASSESS-IT approach to explore whether or not CNS models are necessary to depict the impact of IS on the BP. Section 4.5 summarises the insights

gained in this chapter and provides the basis for the proposal of a new theory to model the interactions between BP and IT.

Chapter Five describes the proposed new approach to create simulation models that depict the interactions between IS and BP and test it by way of the case study. Chapter Five is divided in three major sections. Section 5.2 described the rationale behind the new simulation framework, namely BPISS. Section 5.3 describes the guidelines for each of the tiers in the BPISS framework. A summary of this chapter is presented in section 5.4

Chapter Six describes the application of each of the sixteen tiers of the BPISS framework in the case study described in Chapter Three (section 6.2). Section 6.3 presents a summary of Section 6.2 together with a discussion of the outcomes derived from this chapter.

A summary of the contents of chapter two to six, research findings, and further research are described in **Chapter Seven**.

1.7 Chapter One: Summary and Conclusions

This chapter introduces the reader to the research problem this dissertation attempts to tackle. The introductory section establishes that Business Process and Information Technology are two domains that are closely related. It assumes that this relationship can be seen as a three layered structure, namely BP, IS and CN and presents some evidence that establishes that despite the fact these three domains interact in practice the way this relationship is addressed in BP and IT design approaches could be improved. Section 1.2 briefly investigates the modelling techniques available in BP, IS and CN domains and suggests that most of the modelling techniques in these three domains do not explore how to model their relationships. Section 1.3 suggests that a modelling framework that combines BP, IS and CN modelling techniques can be used to depict the relationships between these three domains. Section 1.3 also provides some evidence that positions discrete-event simulation techniques, in particular BPS and CNS as possible candidates to be used in the aforementioned framework. Section 1.4 describes the objectives that this dissertation aims to accomplish, which can be summarised as follows. First, provide evidence that suggest that the relationship between BP and IT can be explored in more detail and that other modelling techniques, such as DES can be used to help in this matter. Second, identify the parameters that govern the relationship between BP, IS and CN and propose a simulation framework to portray the interactions between BP, IS and CN. Section 1.5 provides some evidence that supports the idea that a case study strategy

is suitable to accomplish the major objectives of this research. Section 1.6 outlines the structure of this dissertation and summarises the contents of the six remaining chapters.

2. Integration of Business Process and Information Technology Models: The Organisational Challenge

2.1 Introduction

This chapter attempts to provide evidence that BP and IT domains have addressed the need to investigate the relationships between BP and IT but have not provided enough guidance as to how this can be done or which modelling techniques can be used to accomplish this task. An analysis of the whole variety of BP and IT design approaches would be beyond the scope of a PhD dissertation. In order to explain the nature and limitations of current approaches, two BP design approaches that can be considered sufficiently representative of current approaches, were selected for examination. The first approach is proposed by Davenport (1993) and the second proposed by Kettinger et al. (1997). Similarly, two IS methodologies that claim to address BP and IT in an integrated way are reviewed: Merise and Information Engineering (IE). To complement the review, this chapter discusses briefly the modelling techniques used in both BP and IT domains. The review of modelling techniques will also help to identify the most suitable techniques to be used in a modelling framework to depict this relationship.

2.2 Business Process Change Design

The concept of process has been used among management practitioners since the mid-1940s (Davenport and Stoddard, 1994) and it has been a matter of research since. For example, process control and process techniques have been outlined in the quality movement (Juran, 1964; Garvin, 1988). Process skills and process consultancy have been very important in human relations and management of change schools (Schein, 1969). Operations management is concerned with the management of processes, people, technology, and other resources in the production of goods and services (Armistead et al., 1995). It was not until the beginning of the 1990's, however, that the process movement became strong. Business Process Reengineering, also named Process Redesign or Process Innovation, is one of the most popular concepts in business management (Davenport, 1993, Hammer and Champy, 1993). The study of business processes, however, is not isolated and has always been related to Information Technology. As discussed in Chapter One, IT is considered one of the most important enablers of process change (Davenport and Short, 1990, Hammer and Champy, 1993).

Organisations have realised that alongside economic, social, and political factors, are important IT driven factors (Tumay, 1996; Bhattacharjee and Hirschheim, 1997). This has led to the development of a great variety of methodologies, techniques, and tools for undertaking Business Process Reengineering projects (Kettinger et al., 1997). Nevertheless, most agree on two issues: a) process-based design methodologies are primarily focused on processes (Kettinger et al., 1997; Grover et al., 2000), and b) Information Technology is considered as a key enabler for process-design (Davenport, 1993; Maull et al., 1995; Powell and Dent-Micallef, 1997). Despite the fact that BPR projects rely on IT to support BP change, this research argues that the relationship between BP and IT should be examined in more depth. To illustrate this point, two methodologies are chosen. Davenport's (1993) process innovation methodology is analysed first. This methodology is chosen as it is an example of one of the earliest process-based design approaches and was developed by one of the first and most renowned advocates of the BPR movement. Kettinger et al.'s (1997) methodology is analysed next. This framework is selected because it is based on extensive research of former and current business process reengineering methodologies, techniques, and tools, in an attempt to provide a generic BPR project archetype. The two methodologies (Davenport's and Kettinger et al.'s), whilst not covering all the variety, are sufficiently illustrative for the purposes of this research study.

Davenport's (1993) framework for process innovation consists of five steps: identifying process for innovation, identifying change enablers, developing a business vision and process objectives, understanding and measuring existing processes, and designing and building a prototype of the new process and organisation (see Figure 3).The following paragraphs contain a brief description of each step.

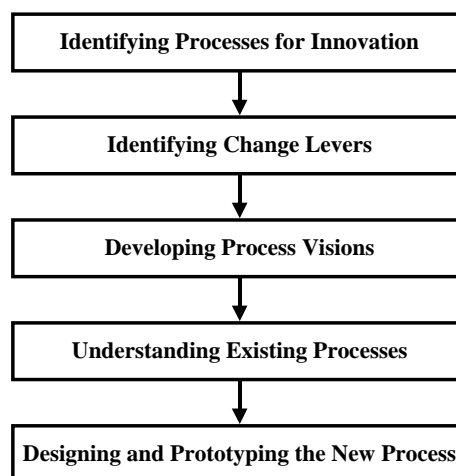

Figure 3 A High-Level Approach to Process Innovation (Davenport, 1993)

Identifying Process for Innovation. The *first* step of this framework detects the processes performed by the organisation in order to select those that are more suitable for redesign.

Identifying Change Levers. The *second* step highlights the importance of identifying enablers of process innovation. The author distinguishes three major enablers: Information Technology enablers, Organisational enablers, and Human Resource enablers.

The *third* step in the framework, *Developing Process Visions*, consists of providing the necessary “linkage” between strategy and action, specifying measurable objectives and attributes of the future process state.

Understanding Existing Processes. The *fourth* step helps to facilitate communication among participants, to facilitate migration and implementation planning, to ensure that recognised problems are not repeated in the new process, and finally to provide a measure of the value of the proposed innovation.

Designing and Prototyping the New Processes. According to the results of step four, it is necessary to propose a number of alternative re-designed processes. These processes are compared and evaluated in the *fifth* step in order to decide a specific solution. In this step, a migration strategy towards the selected solution is formulated, followed by the implementation of the new organisational structures and systems.

Davenport describes a number of "key activities" that need to be performed in each step. Table 2 shows a summary of these activities.

Kettinger et al. (1997) proposed the Stage-Activity (S-A) framework for BPR, merging a wide number of methodologies into an empirically derived framework for carrying out BPR analysis. The Stage-Activity framework comprises 6 stages and 21 activities. The six stages can be categorised as follows:

1. Envision (S_1): This stage involves a BPR champion who provides the support of top management. A task force is authorised to target a business process for improvement based on a review of business strategy and IT opportunities.
2. Initiate (S_2): A reengineering project team set performance goals, project planning, and stakeholder/employee notification and “buy-in”. This is accomplished by developing a business case for engineering using bench-marking, identifying external customer needs, and cost-benefit analysis.

Step	Key Activities
Identifying Process for Innovation	<ul style="list-style-type: none"> ➤ Enumerate major processes ➤ Determine process boundaries ➤ Assess strategic relevance of each process ➤ Render high-level judgements of the "health" of each process ➤ Qualify the culture and politics of each process.
Identifying Change Levers	<ul style="list-style-type: none"> ➤ Identify potential technological and human opportunities for process change ➤ Identify potentially constraining technological and human factors ➤ Research opportunities in terms of application to specific processes ➤ Determine which constraints will be accepted
Developing Process Visions	<ul style="list-style-type: none"> ➤ Assess existing business strategy for process directions ➤ Consult with process customers for performance objectives ➤ Benchmark for process performance targets and examples of innovation ➤ Formulate process performance objectives ➤ Develop specific process attributes
Understanding Existing Processes	<ul style="list-style-type: none"> ➤ Describe the current process flow ➤ Measure the process in terms of the new process objectives ➤ Assess the process in terms of the new process attributes ➤ Identify problems with or shortcoming of the process ➤ Identify short-term improvements in the process ➤ Assess current information technology and organisation
Designing and Prototyping the New Process	<ul style="list-style-type: none"> ➤ Brainstorm design alternatives ➤ Assess feasibility, risk, and benefit of design alternatives and select the preferred process design ➤ Prototype the new process design ➤ Develop a migration strategy ➤ Implement new organisational structures and systems

Table 2 Davenport's Framework Key Activities (Davenport, 1993)

3. Diagnose (S₃): This stage documents the current process and sub-process in terms of process attributes such as activities, resources, communication, roles, IT, and cost. This stage also helps to identify root-causes for problems and non-value activities.
4. Redesign (S₄): This stage is the design of a new process by devising process through the use of brainstorming and creativity techniques. The new process should meet strategic objectives in order to fit in with the human resource and IT architectures. This stage also documents and creates prototypes of the new process together with the design of the IS that supports the new process.
5. Reconstruct (S₅): The reconstruct stage strongly relies on change management techniques to migrate to new process responsibilities and human resources roles. This stage also is concerned with the implementation of the new IT infrastructure as well as the training and transition process of the users.

6. Evaluate (S_6): This stage often is linked to a total quality program, since it involves the monitoring of the new process in order to assess if it meets its goals.

Stages and activities within the S-A framework are depicted in Figure 4.

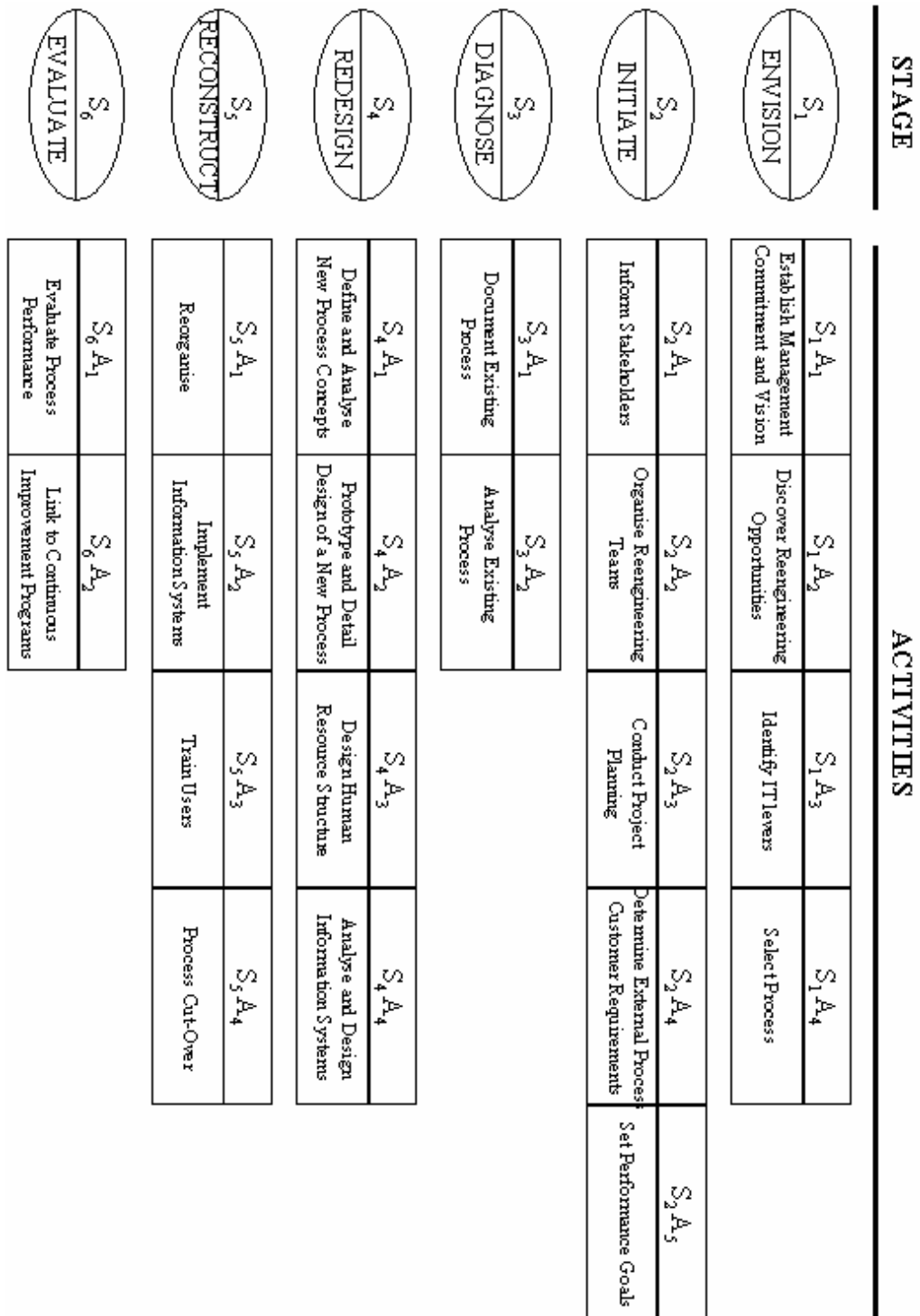

Figure 4 A Stage-Activity Framework for Business Process Reengineering (Kettinger et al., 1997)

2.2.1. A Critique of Business Process Change Design

The review of the methodologies presented above indicates that both reengineering approaches argue that Information Technology is one of the most important enablers for BPR. For example, in step two, Davenport's framework (1993) identifies Information Technology as one of the three main enablers of business change and offers a detailed picture of how IT provides opportunities of change and advocates that the design of IT should be done together with the business processes. Davenport identifies at least nine different categories of opportunities for supporting process innovation with IT (see Table 3).

Impact	Explanation
Automational	Eliminating human labour from a process
Informational	Capturing process information for purposes of understanding
Sequential	Changing process sequence, or enabling parallelism
Tracking	Closely monitoring process status and objects
Analytical	Improving analysis of information and decision making
Geographical	Coordinating process across distances
Integrative	Coordination between tasks and processes
Intellectual	Capturing and distributing intellectual assets
Disintermediating	Eliminating intermediaries from a process

Table 3 The impact of IT on Process Innovation (Davenport, 1993)

The major contribution of Davenport's framework (1993) is that it is one of the first BPR efforts that attempts to coordinate process and IT design and gives sufficient evidence to help identify different ways that IT can be used to improve process performance. Despite the fact that this framework points toward what needs to be done and where, it barely mentions how to do it. Davenport acknowledges that the tools and techniques for achieving process objectives are distinct in use from those for developing information systems. Despite this fact, however, he advocates that IS requirements and data structures should fit in with the corresponding business processes, and that the implementation of IS should be closely coordinated with corresponding process implementation efforts. In an attempt to help in this task, he outlines extant technologies that can play a role in the implementation of processes. Davenport's framework, however, does not supply information that indicates how to assess the impact that the insertion of new IT may have on the processes or which techniques can be used to investigate this relationship.

The differences between Davenport and Kettinger et al.'s reengineering approaches rely substantially on the extent to which they address the design of business processes and Information Technology. For example, the role of Information Systems in enabling change is pursued in more detail in the S-A framework, than in Davenport's work (1993). The S-A framework specifies the activity S_4A_4 to analyse and design IS, and the activity S_5A_2 to implement IS. Another advantage is that this framework clearly indicates modelling techniques and tools that can be used in each of the S-A framework stages and activities. Despite this fact, the S-A framework focuses almost entirely on identifying techniques and tools that can be used in each of the stages for the design of BP and barely mentions how to assess the impact that the insertion of new IT may have on the processes or how the coordination between process and information techniques can be achieved. Although the identification of modelling techniques for process and information system design is more detailed, there is no coordination between process and IS modelling techniques.

Business Process Reengineering is supposed to take a more integrated approach to planning business change and advocates that the design of business processes should be done considering the advantages and limitations that Information Technology can bring to business design. The analysis of the process reengineering approaches presented before, however, still do not provide a clear guidance of how the integration of business process and Information Technology should be done and do not provide details of the techniques and tools available to achieve such integration. The following sub-section reviews current business process modelling techniques in a search for a modelling technique or group of techniques that could help to model the relationships between business processes and information technology. A modelling technique like this, if it exists, could be used to complement the gaps left in existing business process change methodologies.

2.3 Business Process Modelling Techniques

A model must be capable of providing various information elements to its users. Such elements include, for example, what activities comprise the process, who is performing these activities, when and where these activities are performed, how and why they are executed, and what data elements they manipulate. Business Process modelling techniques differ in the extent to which their constructs highlight the information that answers these questions. To provide this information, a modelling technique should be capable of representing one or more of the following modelling perspectives (Curtis et al., 1992):

- *Functional perspective.* Represents what process elements (activities) are being performed.
- *Behavioural perspective.* Represents when activities are performed (for example, sequencing), as well as aspects of how they are performed through feedback loops, iteration, decision-making conditions, entry and exit criteria, and so on.
- *Organisational perspective.* Represents where and by whom activities are performed, the physical communication mechanisms used for transfer of entities, and the physical media and locations used for storing entities.
- *Informational perspective.* Represents the informational entities (data) produced or manipulated by a process and their relationships.

Business Process Modelling techniques are used to develop models of the way an organisation operates, the processes the organisation has and how they are related with different organisational areas in order to give an understanding of possible scenarios for improvement (Hammer and Champy, 1993; Ould, 1995). Flowcharting, IDEF0, IDEF3, Petri Nets, System Dynamics, Knowledge-based Techniques, Role Activity Diagrams, Activity Based Costing, and Discrete-event Business Process Simulation (BPS) are some examples of BP modelling techniques widely used in the organisational domain. Table 4 compares the most popular BP modelling techniques in terms of Curtis et al.'s (1992) process modelling perspectives.

2.3.1. A Critique of Business Process Modelling

According to Curtis et al.'s modelling perspectives (1992), process modelling techniques suffer from a major disadvantage: they do not, or they only barely, address the Informational perspective. This suggests that the process domain considers that the informational aspects of the organisation are not as relevant as the others. Furthermore most of the techniques shown in Table 4 concentrate on portraying at most two process perspectives. According to Giaglis (1999) only discrete-event simulation is able to address fully three of the process perspectives.

Many researchers advocate the idea that business process discrete-event simulation, also named Business Process Simulation (BPS), is one of the most suitable modelling techniques that can be applied to the business process domain. For example, Giaglis (1999) agrees with MacArthur (1994) arguing that simulation is well suited as a design assessment tool in the context of evaluating process change alternatives. Moreover, they assume that measuring process performance is one of the most important problems faced by BPR projects, and therefore, simulation is well positioned, at least in theory, to address

this problem. Similarly, Kettinger et al. (1997) argue that there is a need for a more user-friendly and media-rich capture of business processes, and that simulation can address these issues since it provides easy visualisation and allows team participation in process redesign.

BP Modelling Techniques	Modelling Perspectives			
	Functional	Behavioural	Organisational	Informational
Flowcharting	Yes	No	No	Limited
IDEF0	Yes	No	Limited	No
IDEF3	Limited	Limited	No	Limited
Petri Nets	Yes	Yes	No	No
Discrete Event Simulation	Yes	Yes	Yes	Limited
System Dynamics	Limited	Yes	Yes	Limited
Knowledge-based Techniques	No	Yes	No	No
Role Activity Diagramming	No	Limited	Yes	No

Table 4 BP Modelling Techniques Vs Process Modelling Perspectives (Adapted from Giaglis, 1999)

Business process simulation is an appropriate technique to portray organisational, functional, and behavioural aspects of the system. BPS, however, lacks of the ability to model the informational one. A business process reengineering exercise does not concentrate on merely the analysis of processes but also advocates the integration with information technology. The fact that BPS is currently used as a process design technique limits its scope and it thus cannot be used, albeit alone, as an integrated BP/IT technique. Having observed the limitations and drawbacks of extant process modelling techniques concerning the integration of process and information technology design, the following section focuses on showing that similar problems are found in the information technology arena.

2.4 Information Systems Design

The Systems Development Life Cycle (SDLC) is recognised as one of the first IS development methodologies and was extensively used from its introduction in the late 1960s, until the 1980s when it evolved into many other approaches (Avison and Fitzgerald, 1995; Turban et al., 1996). The advantages of implementing the SDLC are those that are expected of a methodology: it follows a series of specific and sequential phases from the beginning of the project until the end, advocates the use of techniques and tools including ways to evaluate the costs and benefits of different solutions and methods to formulate detailed design to develop IS, and introduces the use of project management tools to control the overall project. Despite the success of the SDLC, the IS community identified a number of drawbacks. Among the most important are:

1. There is a claim that SDLC failed to address top-level management requirements. It is argued that instead of meeting organisational objectives, the traditional SDLC aims to design IS to help to solve low-level operational tasks (Avison and Fitzgerald, 1995).
2. The traditional SDLC focused on "automating" processes rather than proposing innovative solutions (Rhodes, 1998).

Trying to address these limitations, formal IS methodologies emphasise different aspects of the IS development cycle according to the author's perspective. Some methodologies, for example, emphasise the analysis of the organisational processes, others the analysis of the data, and there are those who consider both, processes and data, with equal importance (Vessey and Glass, 1998).

This chapter reviews two methodologies that claim to address IS design and top-level management requirements in an integrated fashion. The objectives of this review are twofold: a) to provide evidence that the way current IS methodologies address high-level organisational requirements leaves room for improvement; and b) to identify possible ways to improve the way current IS methodologies address BP and IT integration. The methodologies to be reviewed are Merise and Information Engineering. The selection of these methodologies is based on the argument that they aim to address the relationship between BP and IT in more depth than other methodologies. For example, Imache (1998) argues that, unlike other methodologies, Merise considers process and data with equal importance. Hares (1992) argues that Information Engineering (IE) is one of the most rigorous IS development methodologies that addresses in-depth business issues as a prerequisite to systems analysis and design. In addition, it is also argued that Merise methodology has been largely used in Europe and America, thus it can be said that to be a sufficiently good representation of a widely used IS methodology (Imache, 1998).

2.4.1. Merise

Merise is the most widely used methodology in many countries including France, Spain, Switzerland, and the United States of America. This approach is suitable for data processing applications that use databases and those in real-time and batch processing environments (Rochfeld and Tardieu, 1983, Imache, 1998). Merise is essentially divided into three cycles: *Decision*, *Life*, and *Abstraction*. It is in the latter cycle where the major contribution of Merise to the information systems development domain is found. It is argued that the way processes and data are modelled in this cycle differs from other approaches. A brief description of decision, life and abstraction cycles is presented next.

Decision cycle

In Merise, decision making is a process where management, users, and systems developers get together and interact. Decisions to be made include:

- Hardware and Software technical choices
- Processing choices (e.g. real-time or batch)
- User oriented choices (e.g. user interface)
- Identification decisions regarding the major actors of the information system and the organisation
- Financial decisions (cost and benefits)
- Management decisions concerning the functionality of the information systems

In Merise, it is essential to know who takes the decisions, especially who decides over the validation of the models used by the method. It is also important to know when a stage is completed and when the following one starts.

Life cycle

The aim of this cycle is to show the chronological progress of the information system from its creation, through its development, until its final review and obsolescence. The main phases of the life cycle are:

Strategic planning (corporate level). This stage maps the goals of the organisation to its information needs. The strategic planning stage divides the organisation into "domains" for further analysis (e.g. manufacture, finance, and personnel).

Preliminary study (domain level). Describes the proposed information systems and discusses their likely impact and costs and benefits, which in turn should be consistent with the strategic plans.

Detailed study (project level). A study of the aspects that will be automated, including detailed specifications for the functional design and the technical design.

Schedules and other documentation. For development implementation and maintenance (all three at the application level).

Abstraction Cycle

Whereas other methodologies treat data and processes separately, in Merise both are treated with equal depth and taken into account from the start. The data view is modelled in three stages: the *conceptual*, the *logical* and the *physical*. Similarly, the process view is modelled through the equivalent three stages: *conceptual*, *organisational*, and

operational. Each of the six stages is a consistent representation, though a partial one, of the information system. The abstraction cycle descends gradually from an overall view of the problem (conceptual), to making decisions related to resources and tasks, and through to the technical means used to implement it. The conceptual stage studies the organisation as a whole, the logical stage addresses questions such as who does what, where, when and how. Finally, the physical stage looks at the resources and technical environment that the system can use.

2.4.2. Information Engineering

It is claimed that Information Engineering (IE) is a methodology that covers all aspects of the life cycle and is viewed as a framework that comprises a variety of techniques that are used to develop good quality IS in an efficient way. The techniques currently used in IE , however, are not part of the framework and thus can be changed as new improved techniques emerge. Although there is some difference of opinion as to the origins of IE, the views of Martin (1989), Finkelstein (1992), and Avison and Fitzgerald (1995) will be included here.

IE follows a top-down approach to systems development. It begins with a top-management overview of the organisation in order to ensure the coordination of other systems. The IE methodology is divided into four levels: the *Information Strategy Planning level* is concerned with the identification of business goals and the articulation of ways technology can be used to achieve these goals. The *Business Area Analysis level* is concerned with developing business models that represent organisational activities and their data requirements. *The System Planning and Design level* is concerned with matching the behaviour of the system with the user requirements and with the extant technology. Finally, the objective of *the Construction and Cutover level* is to build and implement the system as specified in the three previous levels. It is claimed that IE places a heavy emphasis on modelling both business processes and Information Systems. The following paragraphs describe in more detail each of these levels.

Information Strategy Planning (ISP)

The major objective of ISP is a) to direct the design of Information Systems so they meet the requirements of the organisation, and b) to make clear that IS are of strategic importance to the organisation. Hence, ISP is recognised as a fundamental starting point for the methodology. ISP performs an overview analysis of the business objectives, the organisation's major business functions, and information needs. The result of the analysis is called "information architectures", which in turn, form the basis for subsequent

developments. This helps to ensure consistency and coherence among other organisation's systems. It is claimed that this level represents one of the major advantages of IE over other IS development approaches since in most of them these needs are forgotten or never captured.

Business Area Analysis

A detailed data and function analysis of each of the business areas is performed in this level. The tasks involved in this phase are as follows:

Entity and function analysis. This is considered the major task in this level. It involves the analysis and design of diagrams that represent the entity types and relationships as well as processes and dependencies.

Interaction analysis. This examines the relationships and interactions between the data and the functions using entity-relationship diagrams, function hierarchy diagrams and a function/entity type interaction matrix.

Current systems analysis. Using the same techniques as in the entity and function analysis, this task analyses existing systems models, which in turn, will be compared in the confirmation task ensuring in this way a smooth transition from one model to the other.

Confirmation. As mentioned before, this is the comparison of the results obtained in the previous task, in terms of completeness, correctness, and stability. This phase also analyses proposed business changes and the consequences they may have.

Planning for design. This task is oriented to facilitate the system design.

System Planning and Design

This level is divided into business system design and technical design. The information gathered in each design area identified in the business systems design is used to design a system that fulfils these requirements. The design stops when technical issues are identified. The steps involved are: preliminary data structure design, system structure design, procedure design, confirmation, and planning for technical design. The final outcome of this stage is to produce a business systems specification that contains details of each business process, computer procedures, consolidated and confirmed results of business area analysis, dialogue design, screens, reports and other user interfaces. Following this stage, the design of the technical aspects of the business system is performed to the extent that the scope of the proposed computer system is defined together with the work programmes and resource estimates.

Construction and Cutover

This level covers the stages of construction, cutover, and production. Construction is concerned with the development of each defined implementation unit. Cutover, is concerned with controlling the transition from the current system and procedures to the new system. Production ensures the continued successful operation of the system throughout its life. It ensures maintenance of the system and that changes in the business requirements are addressed.

2.4.3. A Critique of Information Systems Design

The résumé of the methodologies presented suggests information systems approaches, such as Merise and IE, focus upon developing better information systems. Although organisational issues are considered to be important they are addressed at the early stages of the methodologies presented. When organisational factors are considered they are used for the design of IS but do not provide proper guidance concerning how to examine the impact the new information system may have on the business processes or which modelling techniques can be used for this matter. For example, Merise's two main cycles (life and abstraction) are concerned with system development. Organisational design issues, however, are treated only within the decision cycle. Moreover, the decision cycle does not investigate thoroughly the limitations that IT may impose on the business process and vice versa. The decision cycle identifies and orders, based on a hierarchy, the decisions that must be made during the life cycle. The way users, senior management, and IT professionals will collaborate and influence IS design in the decision cycle, however, depends on the organisation's norms and is not clearly defined in the literature (Avison and Fitzgerald, 1995).

Merise advocates the use of modelling techniques to support IS design. For example, the abstraction cycle promotes the use of conceptual data models, data flow diagrams, and conceptual processing models to model data and processes equally thoroughly. Process modelling techniques used in this cycle, however, are valid for systems development but not for process design. IS process techniques work well in system analysis but cannot address many of the process modelling needs in process design (Davenport, 1993). Furthermore, although the design of process and data is considered with equal importance, the modelling techniques suggested in Merise are separated and cannot generate a unified view that allows observation of the interactions between business processes and the information system. Information engineering overcomes this problem with the use of a function/entity type matrix, which indicates at a high level which subject

areas are used by which processes. This, however, produces some problems of its own in terms of the complexity of the techniques used. IE uses three modelling mechanisms to depict the interactions between functions and data, creating a complex net of models and matrices. Furthermore, despite the existence of a mapping between processes and the information systems, the resulting matrix cannot provide information that indicates the way the proposed IS may improve process performance.

The rigour of IE renders it suitable for designing and building effective Information Systems to support new process design, though its rather technical and detailed nature hardly makes it suitable for high-level, strategic business change initiatives (Giaglis, 1999). The major strength of the approach probably lies in that it recognises that traditional functional-oriented approaches can result in complex and difficult to coordinate organisational structures. IE, however, fails to conceive the business process as an alternative analysis perspective, and instead advocates organisation-wide modelling, though with some limitations in terms of complexity, cost, and time effectiveness. For example, IE requires the analyst to be familiar with a wide number of modelling techniques and software environments (mainly CASE tools) in the various steps of the process.

One aspect that was consistently addressed by both methodologies is the need to match the organisational needs with the proposed IS. For example, this issue is stressed in Merise in the strategic planning phase within the Life Cycle. Information Engineering considers that to ensure the proposed IS satisfies the organisational needs, it is necessary to address user requirements throughout the first three levels of this approach. The ISP level in IE ensures that the proposed IS will meet the organisational needs and performs a preliminary analysis of the business objectives, needs, and processes. The Business Area analysis level guarantees that the requirements brought by the ISP level are investigated and modelled thoroughly. Finally, the System Planning and Design level ensures that the logical design of the IS addresses the factors identified in previous levels. The IS community, however, has recently identified some problems when capturing IS requirements. The following section discusses different views to capture IS requirements and the problems that may be encountered when overtaking this task.

2.4.4. Requirements Engineering

Traditional IS methodologies, such as the SDLC, reflected a view that user requirements did not change over time, and thus conceptual models could be used to represent the functionality of the system (Rolland and Prakash, 2000). This belief is now being

challenged. Information systems have to adapt to this environment, which in turn implies that requirements are not stable. In order to adapt to this environment, Rolland and Prakash (2000) advocate that requirement validation must now be compared against organisational needs and not against the system functionality. Only in this way can information systems adapt to the ever-changing organisational needs. To address these problems, requirements engineering is an IS domain that extends the remit of the traditional IS modelling approach that answers the question What does the system do? to an approach that answers the question Why is the system like this?. There are many activities involved in the requirements engineering process including eliciting, modelling and analysing requirements.

Capturing requirements is part of the software development process and is concerned with understanding the needs and wishes of the current and new system and finding mechanisms to portray these needs. Most of the IS methodologies argue that this task should be undertaken thoroughly otherwise it could cause user dissatisfaction. Requirements Engineering (RE) is the IS domain that studies how to develop systems that meet user requirements in the best possible way. According to Nuseibeh and Easterbrook (2000), one of the clearest definitions of requirements engineering is provided by Zave and Jackson (1997). They state that requirements engineering is the branch of software engineering that is concerned with the analysis and capture of organisational goals considering the constraints they impose on software systems. RE is also concerned with the relationship between these factors to define specifications of software behaviour, and to their evolution over time and across software families. Nuseibeh and Easterbrook (2000) argue that three relevant points can be identified in the requirements engineering domain:

1. Organisational goals motivate the development of information systems. Organisational goals represent the "why" as well as "what" of an information system.
2. User requirements have to be specified and documented. A proper documentation and specification of user requirements permit the IS practitioner to:
 - a) Capture and analyse user requirements.
 - b) Validate user requirements against the user's needs and wishes.
 - c) Provide proper guidance, so the system developers know with more precision what they have to develop.

d) Verify user requirements, once the system is delivered.

3. User requirements evolve over time.

Systems requirements are divided into two major groups: functional requirements and non-functional requirements (Sommerville, 1997, Britton and Doake, 1996, Bennett et al., 1999). Functional requirements describe what the system does or is expected to do. In other words, they describe the *functionality* of the system. Functional requirements representations usually illustrate the way the system operates, details of the inputs and outputs of the system, and the relationships between the data that the system will hold. Non-functional requirements are concerned with describing how well the system delivers the functional requirements. Non-functional requirements are usually expressed as performance criteria, volumes of data that the system should hold, and security considerations.

Considering that IS interact with the BP and CN domains as described in Chapter One, it can be observed that the non-functional aspects of the IS are the most likely factors that may affect the relationship between BP, IS and CN, since they describe performance criteria. In other words, non-functional requirements can identify the IS parameters that constrain or enhance the whole system performance.

The following section aims to investigate the modelling techniques used in the IT domain in order to: a) identify the techniques used in the IS domain to capture functional and non-functional aspects of the IS, b) identify the modelling techniques used in the CN domain, and c) identify IS and CN modelling techniques that can be combined with BP modelling techniques to propose a modelling framework to depict the interactions between these three domains.

2.5 Information Technology Modelling Techniques

2.5.1. Information Systems Modelling

One of the domains that has supported IS development and has been particularly popular amongst IS developers is *modelling*. Rich Pictures, Conceptual models, Data Flow Diagrams (DFD), Entity Relationship Diagrams (ERD), State-Transition Diagrams, IDEF1x, and Object-Orientation (OO), such as the Unified Modelling Language (UML), can be mentioned as the most dominant IS modelling techniques (Giaglis, 2001). Models in the IS domain can be used to represent many different aspects of the IS process, hence the wide spectrum of modelling techniques. Consequently, the major problem when

representing user requirements (functional or non-functional) is to identify which is the most appropriate technique for the purposes the analyst wants to communicate. Nuseibeh and Easterbrook (2000) suggest some general categories of requirements engineering modelling approaches as well as some examples under each category.

Enterprise modelling deals with understanding the way the organisation operates. To do so, it is necessary to capture the organisation's structure, the business rules that govern and affect the organisation operation, the goals, tasks and responsibilities of the organisation's members, and the data generated and manipulated by the organisation.

Data modelling deals with the manipulation and management of the information generated and used by the organisation. Traditional techniques such as entity relationship diagrams could be used to capture these requirements. Object oriented techniques such as class diagrams, however, are increasingly replacing traditional techniques.

Behavioural modelling deals with modelling the dynamic behaviour of the current and the required system. In this respect it is necessary to model both the way the stakeholders use the current system (manual and IT systems) and the system itself. Traditional structured analysis methods suggest to start by modelling the current system, then by analysing this model to determine the essential functionality and finally by building a model of how the new system is meant to operate. This view is not shared by all approaches. For example, Yourdon (2001) argues that modelling the current system is overwhelming and can be a waste of time. Structure and object-oriented methods provide a variety of methods with different levels of abstraction to model current and required systems.

Domain modelling provides an abstract description of the environment in which the required system will operate. This type of model can provide a detailed understanding of the domain and an opportunity for requirement reuse within a domain.

The benefits brought by IS modelling techniques have made the modelling domain very attractive among IS practitioners, and modelling has been successfully applied in more than one phase in the IS development. In the planning phase, for example, modelling techniques, such as conceptual models, are widely used in most of the IS methodologies. The investigation and analysis phase uses flow charts to ensure that the investigation is thorough. Furthermore, some of the modelling techniques can be applied in more than one phase in the same methodology. Decision Trees, for instance, can be used in the Logical Design and Implementation phases.

Most of the IS modelling techniques specialise in different aspects, depending on the stage at which they are applied. For example they can be used to understand either the overall function of the system in question, to understand IS data structures, or to model the processes involved in the IS. Table 5 shows a classification of modelling techniques (adapted from Avison and Fitzgerald, 1995) according to the stage that they can be applied and the aspect they address.

Stage/Aspects addressed	Overall	Data	Process
Strategy	Rich Pictures		
Investigation & Analysis	Rich Pictures Objects Matrices Structure diagrams Use Cases	Entity Modelling Class Diagrams	Data Flow Diagrams Entity Life Cycle Decision Trees Decision Tables Action Diagrams Root Definitions Conceptual Models (UML)
Logical design	Objects Matrices Structure diagrams	Normalisation Entity Modelling Class Diagrams	Decision Trees Decision Tables Action Diagrams
Implementation	Objects Matrices Structure diagrams	Normalisation	Decision Trees Decision Tables Action Diagrams

Table 5 Classification of Modelling Techniques (adapted from Avison and Fitzgerald, 1995)

2.5.2. Modelling Non-Functional Requirements.

Information systems can be determined by their functionality and also by properties of the whole system such as operational costs, performance, reliability, maintainability, portability, and many others. These constraints, also named goals, quality attributes, and *Non-functional Requirements (NFR)*, play a very important role during the software development process, since they usually work as the selection criteria among a variety of decisions in the development process. Despite these facts, non-functional requirements have been overlooked by researchers and are less understood than other factors in software development. One reason for this might be because NFR are difficult to represent in a measurable way, something that impedes their proper analysis. Mylopoulos et al. (1992), Nixon (1998), and Nuseibeh and Easterbrook (2000) have identified other major problems encountered when dealing with NFR:

1. There is not a formal definition or a complete list of NFR.
2. NFR usually interact with each other, a situation that can cause conflicts and tradeoffs with implementation techniques.

3. NFR are difficult to understand and represent since they have a global impact on the future system.
4. In order to produce a system that meets the NFR, it is important to consider the organisation's characteristics. These, however, vary from one organisation to another.
5. In general, NFR represent properties of the whole system, therefore, it is almost impossible to verify them in terms of individual components.

Trying to address these problems, academics and practitioners have proposed many ways to model non-functional requirements. For example Jacobson et al. (1992) propose the use of a modelling technique namely "use case" to describe the functionality of a given system. According to Jacobson (1992) a use case is a specific way of using the system by describing some part of the functionality. Each use case constitutes a complete course of events initiated by an actor and the system. Therefore, a "use case" represents a particular sequence of related transactions performed by the actor and the system in question. The totality of use cases represents the whole functionality of the system. Use cases then, can be used to document user's requirements, to define contracts between users and IS developers, and to test the correctness of the system.

User requirement techniques concentrate not only on capturing user's requirements, but also on investigating the way they are related. Mylopoulos et al. (1992) and Chung and Nixon (1995), for example, proposed a NFR framework to capture and relate non-functional requirements. The NFR framework uses a goal-oriented approach to capture NFR. After NFR are captured and analysed, the NFR framework finds links between them in order to determine the impact that a given decision would have on the requirements. Nixon (1998, 2000) extends this work and applies this framework to specify a particular group of NFR: *performance requirements*. Nixon adapts the NFR framework to integrate and catalogue a different number of knowledge of performance and information systems, including performance concepts, software performance engineering, and information systems development knowledge such as requirements, design, implementation and performance. Similar to this work, Cysneiros and do Prado Leite (1999) integrate non-functional requirements into traditional conceptual data models, namely Entity Relationships (ER). The objective is to represent NFR and understand their impact on database modelling design.

Having analysed different modelling techniques used in the IS domain, the following section reviews the modelling techniques used to depict the computer network infrastructure.

2.5.3. Computer Network Modelling

Traditionally there have been two different approaches to modelling computer communications systems: *analytic modelling* and *discrete event simulation* (Sauer and MacNair, 1983). As designing computer networks has become more complex in a rapidly evolving field, analytic models are no longer a reasonable basis for the design validation of large networks systems and currently they are not really of interest to practitioners (Sauer and MacNair, 1983; Williams, 1999). As a result, Computer Network Simulation (CNS) tools are being increasingly used to assist designers in modelling complex network systems (Sauer and MacNair, 1983, Basta et al., 1992, Williams, 1999, Law and McComas, 1994b). General-purpose programming languages, communications oriented simulation languages, and communication-oriented simulators, are among the most common CNS software packages (Law and McComas, 1994b). The major advantage of the latter is that most of the features needed to build a model are already pre-designed. The major drawback is that programming within these software packages is restricted and the user is limited by the software facilities (Law and McComas, 1996). With the expeditious development of IT, however, today's software packages have many of the tools needed to create a CN model. Most of the CN software already includes the configuration of many of the market leading computer network infrastructures (e.g. bridges, routers, switches). These packages also include other features such as the modelling of the data produced by a specific IS application in a very simplistic form.

CNS tools may be used to assess different design alternatives or different operational policies by allowing the modeller to explore the behaviour of a proposed system without actually building it. These tools are designed to help the modeller estimate as accurately as possible the performance characteristics of computing and communication networks. Estimating means that the network under study is described via data. The software package executes a dynamic simulation of the network. This in turn will allow the modeller to collect information on the measured performance of the different model elements and overall network characteristics, which are presented as the estimations of the network performance. A list of the benefits of using discrete event simulation models and in particular communication-oriented simulators is shown below (Law and McComas, 1994a).

- Improve system performance
- Reduce expenditures (costs)
- Ensure that performance objectives are met before equipment is bought or leased
- Identify bottlenecks before system implementation

- Reduce system development time

2.5.4. A Critique of IT Modelling Techniques

It has been identified that an IS could be determined by its functionality and by the properties of the whole system, namely non-functional requirements. Therefore IS modelling techniques should be able to address any of these aspects of the IS. This, however, is not the case. IS modelling techniques focus almost entirely on the functionality of the system (e.g. enterprise modelling, data modelling, behavioural modelling, domain modelling, etc). Furthermore, IS techniques are static in the way they represent a particular instance of the IS and cannot be used to predict the impact that the IS will have on other related areas, such as BP or CN.

The analysis of IS design approaches suggested that the proper capturing and analysis of the non-functional aspects of the IS could help to identify the interactions between BP, IS and CN domains. Non-functional requirements, however, are not easy to represent in a measurable way, a fact that impedes their proper analysis. It was found that recent research (Nixon, 2000, Cysneiros and do Prado Leite, 1999) aims to model non-functional requirements by integrating them into static representations of the system. These approaches can be useful to elicit NFR and to match them against IS design in order to meet NFR. The approaches, however, do not provide the means to assess whether the proposed IS meets the NFR identified previously, neither are they useful to investigate how these requirements may affect the organisational performance.

Finally, the analysis of CN modelling techniques helps us to identify that this domain coincides with the BP domain in that they use DES techniques to depict the dynamic behaviour of the system. Computer network simulation is a dynamic technique that portrays the behaviour of data under different conditions (for example different network infrastructure) and over specific period of time. Considering this fact it can be thought that BPS and CNS modelling techniques could be combined so they depict both organisational and informational aspects of the organisation.

2.6 Chapter Two: Summary and Conclusions

Based on the assumption that an interaction between business processes, the information systems that support those processes and the computer network infrastructure that supports the information systems exists in practice and that due to this relationship changes in any of these domains may have an impact on the others, this chapter investigated the way business process and information technology design approaches

attempt to capture this relationship. Two BP and two IS design approaches were reviewed. This chapter found that the BP approaches reviewed investigate how IT can be used to improve process performance but only in the very early stages. The approaches, though, barely investigate the impact, positive or negative, that the insertion of new IT may have on the processes and in the organisation as a whole. Moreover, BP and IT modelling techniques reviewed in this chapter cannot, albeit alone, achieve this aim. The review of BP modelling techniques provided some evidence that BP approaches attempt to investigate the impact that changes on business processes might have on the organisation. Business Process Discrete-Event Simulation (BPS) is widely used by BP practitioners as a design assessment tool in the context of evaluating process change alternatives. Moreover, BP practitioners believe that measuring process performance is one of the most important problems faced by BPR projects and that BPS is suitable to address this problem. The way this technique is used, though, focuses only on business process factors and do not include the IT aspects that may affect business process performance.

A similar review was performed for the IS domain and two IS design approaches that claim to address BP and IS issues in a coordinated way were reviewed in an attempt to identify how the IS domain addresses the interactions between BP and IT. Two major outcomes were derived from this review.

1. IS approaches attempt to address organisational issues for the design of IS but they do not attempt to investigate the impact that the new IS may have on business processes or in the computer network infrastructure. Modelling techniques are used to ensure that the proposed information system satisfies the organisational goals but this task is often performed addressing only the functional aspects of the organisation. Non-functional aspects, such as performance criteria, time constraints, and security considerations are barely addressed in the very early stages of the IS design and are used only for IS design purposes and not to evaluate different scenarios. The IS modelling domain does not count on modelling mechanisms that could be used to verify that the IS complies with the aforementioned non-functional requirements or to try different IS scenarios before its implementation.
2. The review suggests that the non-functional aspects of the IS are the most likely factors that may affect the relationship between BP, IS and CN since they describe performance criteria. Non-functional requirements can be used as the parameters that

could bridge BP, IS, and CN modelling domains in an attempt to portray the dynamic interactions among them.

This chapter suggests that BP and IT practitioners could be provided with modelling mechanisms to investigate the impact that a proposed IT may have on the BP or vice versa. The BP domain has identified the need to investigate the effects that changes to business process may have on the performance of the organisation before their implementation and the need to experiment with different BP scenarios. Considering this together with the fact that changes to the IT infrastructure, IS and CN, may have an impact on the business processes performance, IS and BP practitioners should count on modelling mechanisms to portray the relationships among these three domains. Painter et al. (1996) have addressed this area and propose a simulation-based methodology, named BPR-II, to assess the impact of changes to business processes and the infrastructure mechanisms that support those processes. They argue that the BPR-II methodology and an accompanying automated support environment will provide the ability to link models of both business process and the supporting IT infrastructure. Painter et al., (1996) propose the insertion of a 'middle' layer between BP and CN which consists of models that depict the IT applications which run on the CN and support the BP (Figure 5).

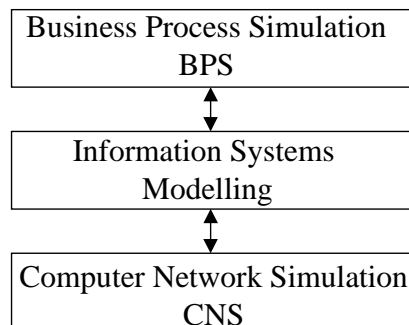

Figure 5 BPS and CNS Integration (derived from Painter et al., 1996)

The authors propose the use of the IDEF3 Process Description Capture method as the key mechanism for process knowledge capture and organisation. IDEF3 process descriptions are used in this methodology to capture a definition of the process at all three levels, namely business process, application and network processing, and to directly generate the structure and logic of simulation models reflecting these levels. Probably one of the major contributions of this approach is that it recognises the need to integrate process and information technology design and identifies an intermediate layer, information systems, as the link between process and computer networks. The modelling techniques proposed in this approach, however, have some restrictions. Table 4 shows that IDEF3 is a modelling technique that can be used to depict how a particular system or

organisation works. IDEF3 however, is not very appropriate for process change initiatives, as it exhibits very limited capabilities to portray the organisational and behavioural perspectives. Moreover, the tools to derive BP and IS models from IDEF descriptions do not necessarily produce a final integrated model and further design and development may be needed towards this integration. Another possible disadvantage of this methodology is that in order to achieve model integration it produces an elaborate net of models with a high level of complexity, which in a large exercise would be almost impossible to follow. Furthermore, other BP simulation tools, such as BPS, have proved to offer a friendlier user-environment that makes the elaboration of BP models simpler than the one proposed in their research. Finally, IDEF3 is a static technique whereas simulation is a dynamic modelling technique. Data interchange between dynamic and static techniques adds another degree of complexity.

Summarising, this chapter highlights the need to combine process and information technology efforts to portray the dynamic interactions between these domains and suggests that a major constraint to accomplish this task is the way extant BP and IT modelling techniques are used to cope with this problem. The review of modelling techniques suggests it is very improbable that a single modelling technique can solve this problem. It has been shown, however, that a combination of process and IT modelling techniques could be used to address the relationship between BP and IT. This research argues that considering the advantages provided by BPS and CNS, they could be used in a simulation framework to predict the impact that changes in the IT infrastructure may have on the business process and vice versa. To this end, Chapter Three uses the insights gained in this chapter to propose a simulation framework to address the interactions between BP, IS and CN.

3. Modelling Business Process and Information Technology

3.1 Introduction

The literature review carried out in Chapter Two illustrated that many process design approaches claim that information technology is a major enabler of business process, a view also shared by the information systems community. Despite the fact that both, process design and information systems approaches, argue that IT plays an important role in process design, they do not provide any clear guidance of how to capture BP and IT interactions or clear indication of the modelling techniques that could be used to depict these interactions. Moreover, the review of business process and information technology modelling techniques presented in Chapter Two, also showed that it is very unlikely to find a single modelling tool that can capture process and IT interactions. This chapter presents a modelling approach that combines business process and information technology modelling techniques to portray the interactions between process and information technology and it is tested using a case study.

Chapter Three is divided into 5 major sections. Based on the findings of Chapter Two, section 3.2 justifies that business process discrete event simulation, also called Business Process Simulation (BPS) and Computer Network Simulation (CNS) are two possible candidates to be used in the simulation framework. Section 3.3 proposes a simulation framework, namely ASSESS-IT, to bridge business process and information technology models using BPS and CNS. Section 3.4 is an introduction to the case study. It describes the case study background, the scope and objectives of the case study, the problem identification, and finally, describes in detail current business processes. Section 3.5 describes the development of business process and computer network models derived from the case study. Conclusions are presented in section 3.6.

3.2 Modelling Process and Information Technology Using Discrete-Event Simulation

The fact that simulation has been successfully used in the process domain posits this technique as one possible candidate to address the business process and information technology integration problem. As described in Chapter One, the BP domain has largely used BPS models to assess the impact that changes to business processes may have on the organisation and to explore different BP scenarios (Gladwin and Tumay, 1994,

MacArthur et al., 1994, Warren et al., 1995, Hlupic and Robinson, 1998, Giaglis, 1999). This technique, though, explores only business processes factors that may affect the overall process performance but does not consider how new IT may affect business process performance. Some research has already tried to address this problem (Painter et al., 1996, MacArthur et al., 1994). These approaches, though, combine dynamic with static modelling techniques to link BP, IS, and CN modelling domains losing in this way the advantages that simulation techniques provide to depict dynamic behaviour. This research attempts to investigate the suitability of using discrete event simulation techniques in a modelling framework to depict BP and IT interactions. It investigates the possible ways to link CNS models results to a BPS model so that the impact that IT may have on BP is reflected on the BPS model. The review on CN modelling techniques suggested that current CNS are able to model both the computer network behaviour and they way IS applications may affect network behaviour. Thus, the modelling framework proposed in Chapter Three attempts to combine BPS models to portray the organisational aspects and to relate this model to a CNS model to address both IS and CN factors that may have an impact on BP process performance.

Chapter One identified that the non-functional aspects of the information system (NFR) such as performance criteria, are the most likely factors that may affect IS performance and that current IS modelling techniques have limited capabilities to model NFR. This research assumes that because IS interact with BP and CN domains, non-functional requirements may also affect BP and CN performance. Therefore, the modelling framework proposed in the following sections will be used to address two major aims. One, to investigate the suitability of using BPS and CNS to depict the dynamic interactions between BP and IT. Two, to explore the way non-functional aspects of the IS may affect this relationship and to investigate possible ways to portray them.

3.3 Business Process and Computer Network Simulation Integration Approach

Business process changes usually involve changes to the information systems. Similarly, modifications to the information system architecture or the insertion of a completely new software application increases or decreases the network traffic load. Consequently, depending on the network infrastructure, changes in the network traffic level may affect the communications between the network components throughout the network (nodes, servers, routers, communication lines, etc.). This has an impact on the performance of the

software applications that run across the network, including the information systems that support the business process under analysis, which in turn, may have unexpected consequences in the business process performance. A business process simulation model cannot be used, as it is, to measure the degree in which new information technology infrastructure (both information systems and computer networks) will increase business process performance. Today computer network simulation models, on the other hand, can reproduce a computer network environment together with the software applications that run across it, but cannot model business processes. The simulation exercise presented here focuses on investigating the suitability of using discrete event simulation models to assess the impact of the insertion of IT in organisational processes. Two discrete event simulation techniques were selected to model both business process and IT: Business Process Simulation and Computer Network Simulation. CNS was selected for two major reasons. First, it is one of the most popular discrete event simulation techniques to model computer networks, and second, it offers capabilities to model software applications. The following section describes the rationale for proposing a simulation framework, namely ASSESS-IT, that combines BPS and CNS in an attempt to model the behaviour between BP and IT.

3.3.1 BPS and CNS Integration Approach: The ASSESS-IT Framework

In order to calculate the business effects of changing the underlying IT, this approach aims to develop a computer network simulation model, including IS, identify the information that may be relevant to the BPS model and incorporate it in the latter. That is, if a CNS model of the proposed IT system is built, the outputs from this model can be directly fed into the business process model, thus reflecting the changes that the new IT would produce at the BP level (see Figure 6).

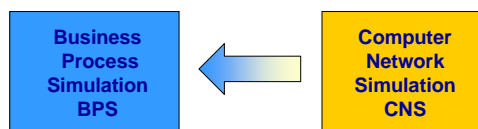

Figure 6 Business Process and Computer Network Integrated Simulation Approach

Because the ASSESS-IT framework aims to use simulation techniques, this research looks at current simulation approaches and how could they be used in the ASSESS-IT framework. It was found that simulation practitioners have identified a series of steps that compose a typical simulation study (see Law and Kelton, 2000, Banks et al., 2000,

Shannon, 1975, Gordon, 1978). The following steps are a résumé of those suggested in Banks et al. (2000):

1. Problem formulation. A statement of the problem should be the starting point of every study. Policymakers and the analyst should sit down together and agree on the formulation of the problem.
2. Setting of objectives and overall project plan. The objectives will indicate the questions that the simulation model should address. The overall study should be planned in terms of the number of people, the cost, and the time needed for each aspect of the study.
3. Model conceptualisation. Although there are not many firm rules about how to design the simulation model, most of the authors are in agreement that it is always better to start with a fairly simple model of the system, which can later be made more sophisticated if necessary.
4. Data collection. The available data of the system in question is collected in this phase. The data collected should be used to specify operating procedures and probability distributions for the random variables used in the model. If possible data on the performance of the system should be gathered for validation purposes (see step 6).
5. Model translation. Due to the complexities of the systems that are being modelled, most simulation is performed by computers. This means that once the model has been designed and the data collected, the model must be converted to a computer program. This is usually done through an appropriate simulation package.
6. Verification. The modeller is responsibly for verifying that the input parameters and the logical structure are correctly represented in the computer model. Usually experience and common sense help in achieving this task. Further information in relation to different techniques to verify and debug computer simulation models can be found in Law and Kelton (2000).
7. Validation. A valid model is an accurate representation of the real system. A common technique to validate a model is to compare the results obtained from the pilot runs to those outputs from the actual system. This calibration process continues until the output of the model is judged acceptable. Once the model has been “validated” as a good representation of the system, the experimentation process can begin.

8. Experimental design. This phase determines the alternatives that are to be simulated. For each system design to be modelled, decisions have to be made on issues such as initial conditions for the simulation run(s), the length of the warm up period (if any), the length of the simulation run(s), and the number of independent simulation run(s) (replications) to make for each alternative.
9. Production runs and analysis. The results of a simulation run can only be analysed after a series of production runs. The results and analysis may highlight issues that were not considered before and thus another set of production runs may be needed until the modeller is satisfied.
10. More runs? The analyst should determine, based on the information collected in step 9, if additional runs are needed as well as the design that those experiments should follow.
11. Document, present, and implement results. Because simulation models are often used for more than one application, it is important to document the assumptions that underpinned the model as well as the computer program itself.
12. Implementation. If the previous eleven steps were performed correctly, it is quite probable that the implementation would be successful. Success also depends on the involvement of the model user during the model-building process. The modeller has a better understanding of the system and the model when he/she maintains constant communication with the user.

The number of steps in a simulation study as well as the order they follow, however, vary from one author to another. This research found that the simulation steps proposed in Banks et al. (2000) could be used as the basis in the ASSESS-IT framework because of the following reasons. First, the simulation steps proposed in the framework developed by Banks et al. (2000) are more specific than other approaches. For example, in this framework problem formulation, setting objectives, and model conceptualisation are specified as separate steps whereas these are not clearly defined in other approaches. This is relevant for the ASSESS-IT framework because it can be easier to identify how the simulation study contributes to the different phases of BP and IT design approaches. Second, unlike other approaches, this framework specifies that there is an iteration process between experimentation and analysis of the results. It is suggested that the results can be used to determine other possible experiments. This research advocates

that this is an important issue since the ASSESS-IT framework aims to use the results from the CNS to determine the impact of IT may have on BP and to identify other possible BP and IT scenarios. Hence the iteration between results and experimentation will be needed.

The simulation steps proposed in Banks et al. (2000) aim to develop a single simulation model. The ASSESS-IT framework, though, aims to develop two simulation models and to share the results obtained from each other so that changes in one model are reflected in the other. Therefore, the following modifications to the aforementioned steps were derived.

- The ASSESS-IT framework duplicates Banks et al's steps for each of the models. The left column in figure Figure 7 depicts the steps to follow for the BP model, whilst the right column depicts the steps to follow for the IT model.
- To coordinate the design of BP and IT so the corresponding models include both BP and IT views it was proposed that the *problem formulation* and *setting of objectives and overall project plan* steps should be performed together for both business process and computer network models. In this way both BP and IT analysis can share common information that can be used for both BP and IT models.
- To coordinate the conceptualisation of the BP with the CN models and vice versa so they reflect both process and information technology issues a new step, *BP/IT model conceptualisation* (4a and grey coloured in Figure 7) is introduced. This step aims to verify that IT issues are considered in BP design and vice versa.
- Steps 5, 6, and 7 are performed as suggested in the previous framework for the BP model. As for the CN model, the subsequent steps follow the framework suggested in Banks' framework.
- A new step (10a and grey coloured in Figure 7), *interchange data between models*, is introduced in the BP model steps. Before undertaking the experimental design step, the BP modeller should wait for the input from the CN model results (e.g. transmission times over specific network conditions). This information needs to be considered for the experimentation design phase in the business process model.
- If more runs are needed in step 10 in the business process model, another decision needs to be made (step 10b and grey coloured in Figure 7). If the decision in the

business process implies changes to the IT, both models need to start at the step 4b, otherwise the BP steps continue normally. It is expected, though, that changes to the models will not be of great significance. Therefore, the following steps should be completed quicker than in the first round.

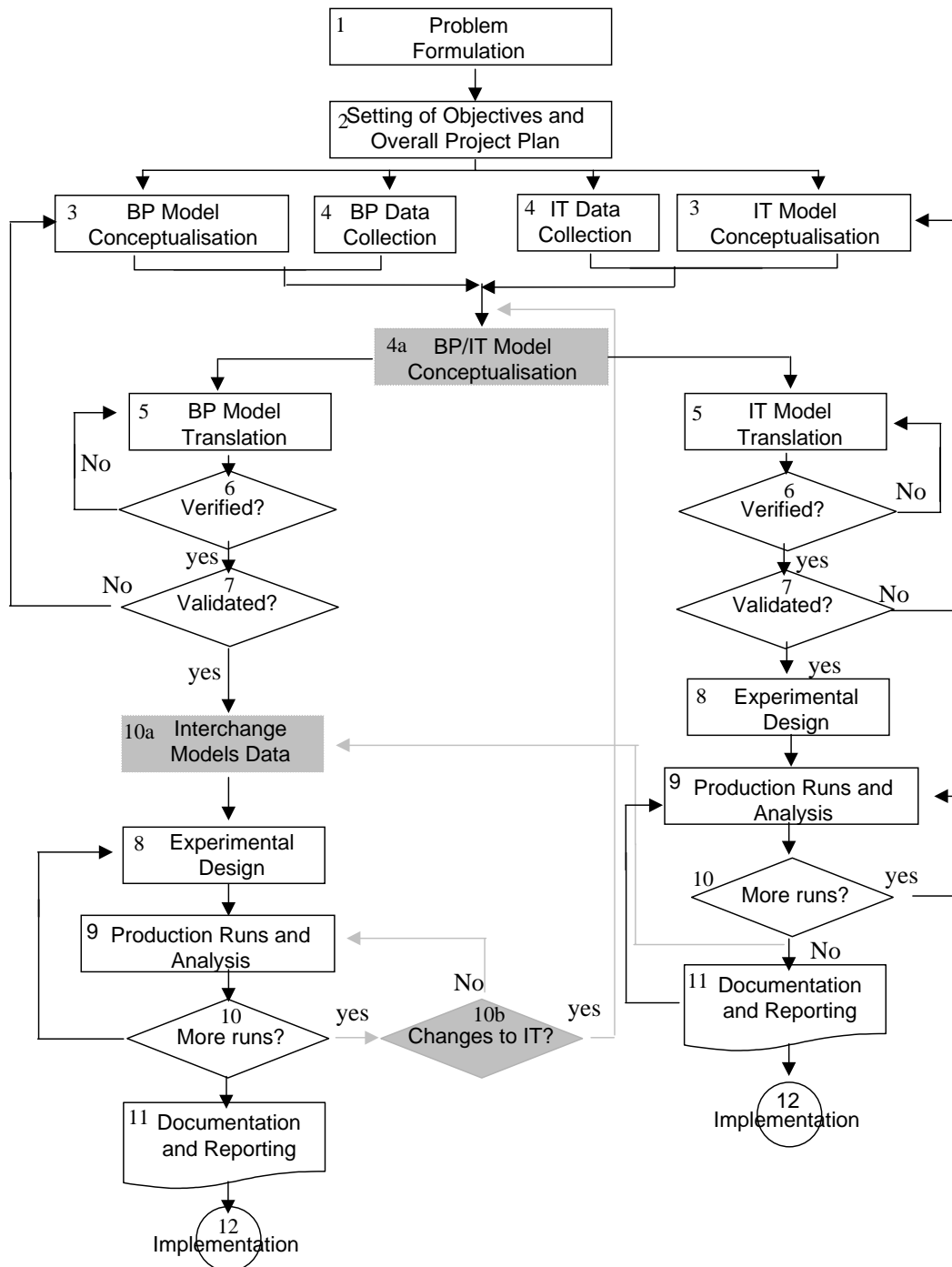

Figure 7 ASSESS-IT Simulation Framework

This research assumes that the changes proposed in the ASSESS-IT framework will help to coordinate the design of BP and CN models so they can reflect design issues during their development. Furthermore, exchanging results from the CNS model to the BPS model will help to reflect the impact that the proposed information system may have upon both the network infrastructure and business processes. The following section describes the application of the ASSESS-IT framework in a case study.

3.4 The Case Study

3.4.1 Background

Two organisations are considered in the case study presented here. One company is a branch of a multinational pharmaceuticals organisation (we will refer to this company as Org-A), while the other is a small organisation that distributes Org-A's products (we will refer to this company as 'Org-B'). Org-A is part of a wide multinational family of pharmaceuticals companies which together comprise 190 operating companies in 51 countries around the world that sell products to more than 175 countries. Org-A's parent company is the world's largest manufacturer of health care products, has more than 99,000 employees and serves the consumer, pharmaceuticals, and diagnostics markets among many others. Org-A was founded in 1974. In 1976, Org-A opened a production site in order to manufacture and market products for South Europe and the Middle East. Today the company employs more than 300 people at three sites. The headquarters are in Athens; the plant and the warehouse are located in Mandra, a suburb of Athens; a smaller office responsible for managing Org-A sales for northern Greece in Thessaloniki, the second largest city in Greece.

Org-A has two different divisions: Medical and Commercial, which operate independently from each other. The case study analysed in this chapter was carried out in the Medical division. This division deals with hospital goods such as surgical dressings, disposable surgical packs, and medical devices like blood glucose and monitoring systems. The Medical division has as major customers large public sector organisations like hospitals, health care organisations, networks of physicians, and the government. The Commercial business unit deals with other business customers that sell Org-A products to end consumers (for example chemists and supermarkets). The commercial division is involved in producing and marketing the products. The Medical division does not produce goods but instead imports them from other Org-A production sites in Europe and these are stored in the Mandra warehouse. This means that the warehouse is the departure point

for all the products that are distributed to the company's customers through a variety of distributors. One of these distributors is Org-B.

Org-B is a small company based in Thessaloniki employing nine people, including five company drivers (data collected at the time of the case study). Org-B has an agreement with Org-A which means is the exclusive distributor of Medical unit products for northern Greece. The agreement signed between both companies states, among other issues, that Org-B is responsible for:

- a) Receiving orders from Org-A customers.
- b) Maintaining an adequate inventory of products that fulfil the orders.
- c) Distributing the ordered products to customer premises.

Org-A has its own site in Thessaloniki consisting of a small team of salesmen and office staff. The salesmen are responsible for informing customers about Org-A's variety of products, obtaining and preserving company customers, and signing sales contracts.

3.4.2 Scope and Objectives of the Simulation Exercise

Org-B has to operate within rigorous deadlines. Both Org-B and Org-A agree that an order has to be fulfilled within 24 hours, for products delivered within the city of Thessaloniki, or within 48 hours for the rest of northern Greece. Org-A has noted, however, that the targets agreed beforehand are rarely met in reality. Preliminary discussions between Org-A and Org-B indicated that the problems seemed to be due to:

- a) Inefficiencies in the ordering process.
- b) The inability of Org-B to maintain an optimal level of product inventory to support order fulfilment.
- c) Problematic and inflexible communication and information exchange mechanisms between the two companies.

Considering that these issues were a major source of customer dissatisfaction, it was decided to:

- a) examine in depth current business process in order to identify possible bottlenecks that produce high order fulfilment lead times.

- b) propose alternative process solutions to the problems identified.
- c) evaluate the potential of using new IT infrastructure to improve communication and process performance.

The introduction of new processes and IT would require a considerable investment for both organisations in terms of hardware, software, telecommunications, and business re-organisation. One of the major problems faced by Org-A and Org-B managers is to evaluate that the insertion of new IT and business process will indeed meet the organisational goals.

3.5 Applying The ASSESS-IT Framework

The ASSESS-IT framework aims to provide a way to coordinate business processes and information technology simulation models design. The ASSESS-IT framework proposes to use BPS models to capture the organisational processes and CNS models to capture the IS and CN infrastructure. These two models will be designed in a coordinated way so that BPS models reflect IT constraints and CNS models reflect organisational ones. Following the design phase, the models will exchange results so they can reflect the dynamic behaviour of both BP and IT. Because the ASSESS-IT framework uses only discrete-event simulation techniques the models can be used to analyse current situation (as-is models) and to explore different scenarios (to-be models). Current business processes of the case study presented here do not rely on any IT infrastructure, therefore, the analysis of current systems will focus only on organisational issues. The application of the ASSESS-IT framework is divided into two phases. Phase one is described in section 3.5.1 and depicts Org-A and Org-B business processes as they currently are. Phase two (section 3.5.2) describes the development of CNS models.

3.5.1 Phase one: BPS Model Development

Business Process Problem Formulation

Org-A and Org-B managers identified, after a series of discussions and a brief analysis of the current processes, the following problems:

- a) *Excessive Order Lead Times*. Orders are fulfilled under lead times that were far higher than the targets specified by both organisations. Moreover, the levels of stock are not appropriately maintained. This in turn produces the request of backorders, which contribute even more to the order fulfilment time.

- b) *Inappropriate inventory replacement policy.* In order to solve the problem of having a great number of backorders, the Org-A warehouse managers implemented a generous replenishment policy for Org-B's warehouse. This policy, however, causes other problems. For instance, it causes considerable warehouse holding costs for Org-B. Similarly, this policy also causes problems related with sensitive medical products reaching their expiry date.
- c) *Poor customer service.* A considerable number of customer complaints, regarding delivery delays.
- d) *Excessive Invoice Lead Times.* Invoices take too long to reach customers, which in turn causes poor cash-to-cash cycle for both organisations.
- e) *Data and Work Duplication.* Org-B and Org-A use different warehouse software to monitor their stocks. Org-A needs to know the stock levels at Org-B in order to plan and schedule replenishment shipments. Therefore, Org-B's stock levels are sent to Org-A. Three major problems can be identified from this scenario. First, data duplication between both companies. Secondly, duplication of work (double typing the same information). Finally, some mismatch between the data reported in Org-B and Org-A databases was reported.
- f) *Information Sharing.* Org-B and Org-A information infrastructures are incompatible. Consequently, the companies have to rely on paper forms to share information. This causes the duplication of data and effort, which in turn produces slow processing times.

Two contributing factors to the problems faced by both organisations were identified. One, business processes were poorly designed. Two, it was found that the IT infrastructure in both Org-A and Org-B IT was incompatible, poor, or in some cases non-existent. The two companies then decided to a) identify process bottlenecks and propose possible business process scenarios, b) investigate the potential of using a new IT infrastructure to facilitate information exchange. Both organisations propose to analyse the introduction of Electronic Data Interchange (EDI) in order to provide faster and more reliable exchange of information. It was believed that EDI would contribute to managing the inventory more efficiently helping in this way to reduce the backorders, eliminate work duplication and data errors, standardise IT infrastructures in both companies, and finally to share

information in a more efficient manner. Consequently, order and invoice lead times were also expected to be reduced.

Business Process Model Conceptualisation

Most of the problems of Org-A and Org-B processes are found in the ordering process. Consequently, the simulation exercise will focus on the ordering process and the IT infrastructure that will support this process. An analysis of the order fulfilment process is needed, and is described further in this section

The Order Fulfilment Process (OFP)

The OFP can be seen as the group of activities that are undertaken from the moment a client places an order until the customer receives the goods together with the corresponding invoice. The OFP can be divided into three major sub-processes, the Order Taking Process (OTP), the Warehouse Management Process (WMP), and the Invoicing Process (IP). Figure 8 is a graphical description of product and documents exchange during the OFP.

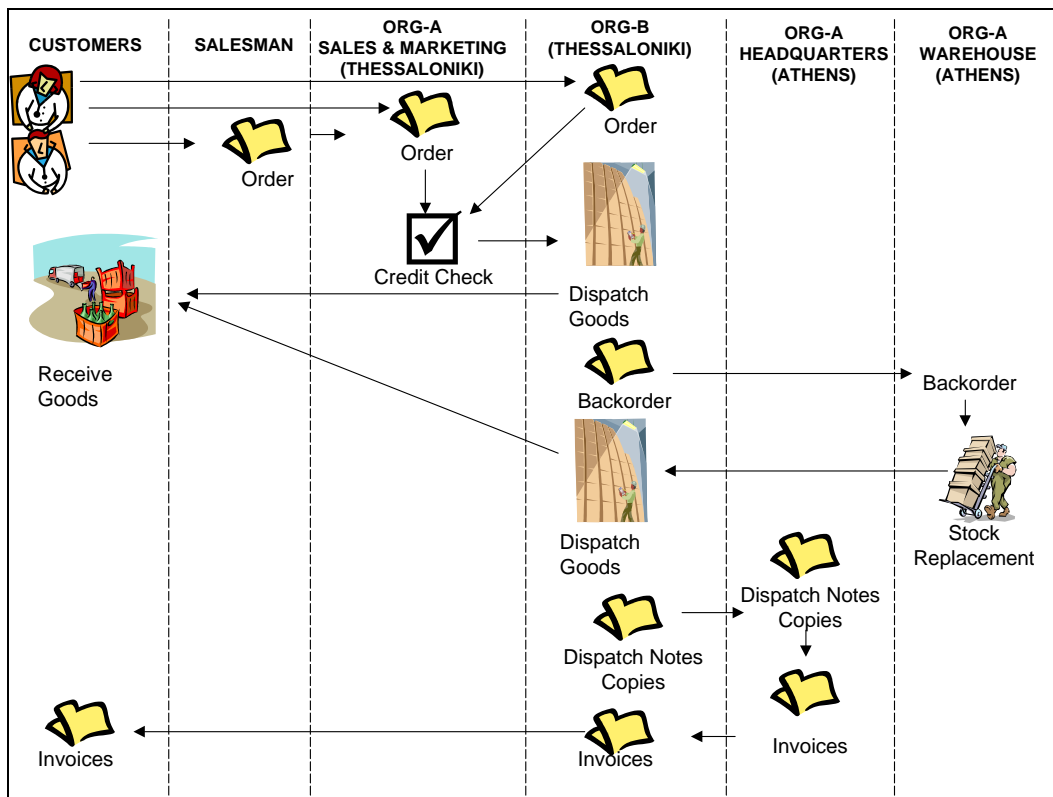

Figure 8. The Order Fulfilment Process (OFP)

The OFP consists of three inter-related, but relatively independent sub-processes. There are now described.

The *Order Taking Process (OTP)*. This process starts at the moment a customer places an order. There are four major actors in the ordering process. One, the customer that places an order. Two, Org-A (Thessaloniki offices). Three, Org-B, and four, a group of salesman, all of whom can take an order from the customer. Orders can be received by phone or fax (Org-A and Org-B) or directly taken by a salesman who visits the customer's site and then delivers or sends the order via fax to Org-A. Because orders need to be checked against the customer contracts held in Org-A, only Org-A can authorise, modify, or reject a customer order. Thus, Org-B also has to send the orders they receive to Org-A to be authorised or rejected. Figure 9 illustrates the OTP scenario.

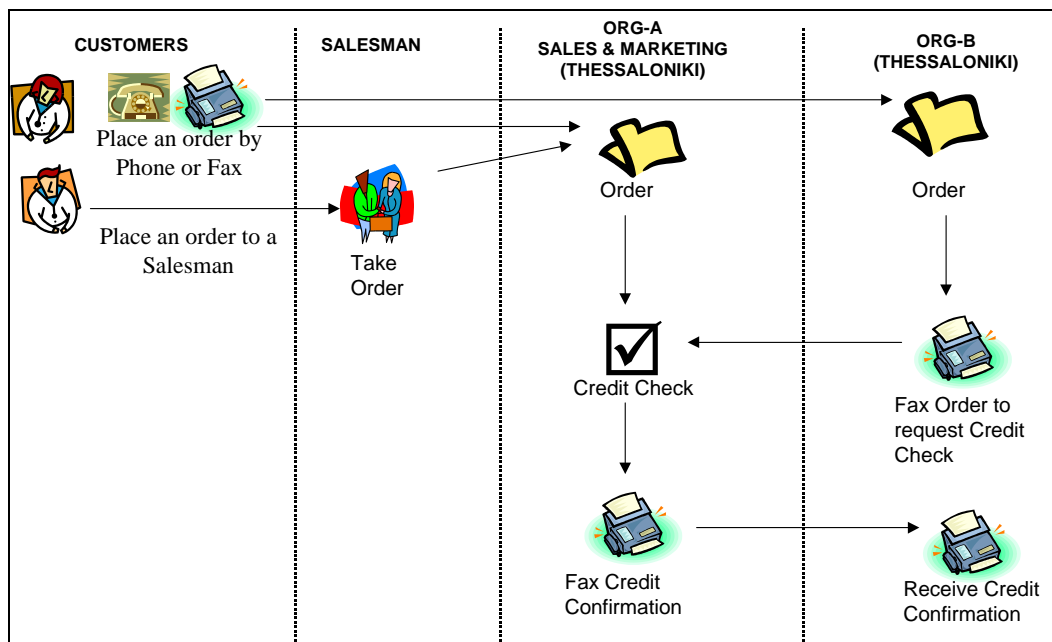

Figure 9. The Order Taking Process (OTP)

The *Warehouse Management Process (WMP)*. After an order is authorised, Org-B has to check their inventory to see if the items in the order can be shipped. If so, the delivery of products is scheduled and a despatch note is issued with the goods. When the products or some of the products are not in the inventory stocks, however, a backorder is produced for the products that are missing and a partial dispatch note is issued for those products that can be delivered.

Org-B sends a backorder list to the Org-A warehouse in programmed intervals. The list contains all the products that were out of stock for all the orders received at a certain time. Once the backorder list is received at Org-A warehouse, a shipment to Org-B is scheduled. The shipment usually includes the products that were "back-ordered" together with a regular replenishment of Org-B's warehouse stock (historical sales data and current inventory levels are used to decide on regular, non-backorder, replenishment). See Figure 10 for a graphical description of the Warehouse Management process.

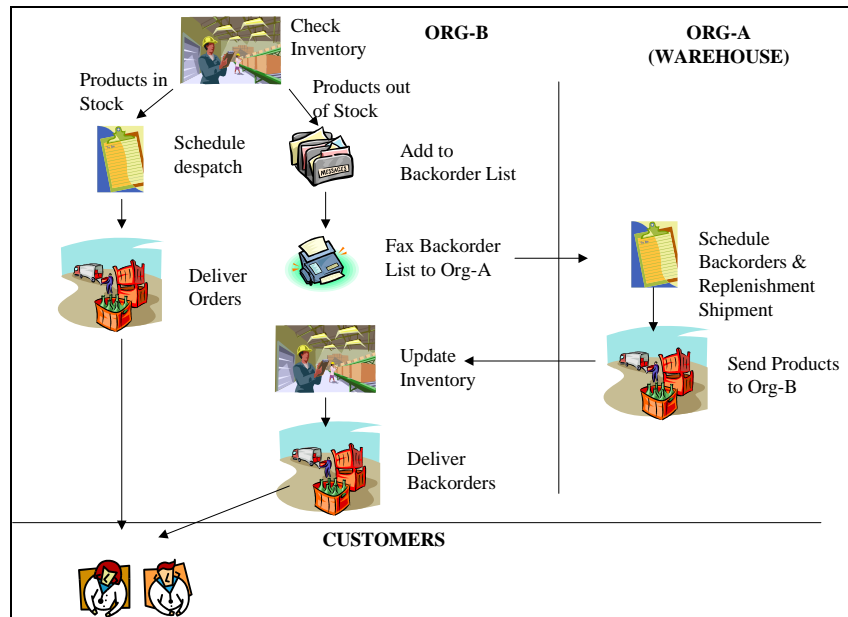

Figure 10. The Warehouse Management Process (WMP)

The *Invoicing Process (IP)*. According to Greek law (information collected at the time of the case study), a legal entity cannot issue invoices for goods unless the goods belong to them. Org-B only distributes the products to customers and does not legally own them at any time. Therefore, Org-A headquarters is the only place where invoices can be issued. Due to this, Org-B collects copies of the dispatch notes issued until a specified time interval and sends them to Org-A HQ. Org-A HQ then uses those dispatch notes to issue the corresponding invoice, which is in turn sent to Org-B. Then Org-B sends the invoice with the earliest product delivery schedule for that customer. The reason invoices are sent in this way is to reduce costs in invoice delivering services. Invoices, however, are rarely sent together with the products they describe. Figure 11 depicts the invoicing process.

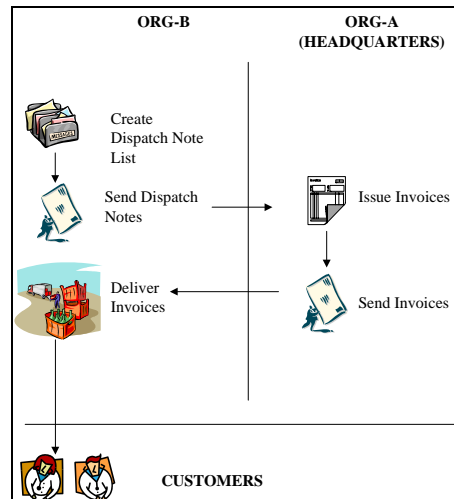

Figure 11. The Invoicing Process (IP)

Business Process Data Collection

In a simulation exercise there is the need to gather quantitative data in order to portray the dynamic behaviour of the processes under analysis. Preliminary information was gathered during interviews and workshops at the early stages of the project. The conceptualisation phase, however, showed that further data was needed to complete the simulation model. The data collected and used for the business process simulation model are fully described in Giaglis (1999) and Paul et al. (2000).

Business Process Model Translation

Deciding the program language or simulation software to translate the information collected previously into a computer is a part of the model translation phase. There are two major reasons that drove us to select CACI's Simprocess software as the business process simulation software. First, the features provided by Simprocess fulfil all the requirements to model the business process described in the case study. Secondly, and most importantly, CACI also offers a CN simulation software, namely COMNET III. COMNET III relies on the same simulation principles as Simprocess and it is better, for the integration purposes, to use two simulation packages that are compatible in this respect.

Business Process Verification and Validation

The graphical interface of the simulation software was used to determine the correctness of the model. All the different entities in the system were monitored to ensure that they followed the corresponding decision paths. Similarly, all different activities, resources, and

other entities were observed in order to verify that they behave closely to the way they do in the real system.

Once the model was correct, it was necessary to establish that the simulation model was an accurate representation of the real system. To do so we compared the data output from the simulation model to those gathered in the data collection. An iterative process followed until the data produced from the model runs were as close as possible to the real data.

3.5.2 Phase Two: CNS Model Development

Computer Network Data Collection

A computer network model was proposed and developed in COMNET III. This model was created with the purpose of obtaining measurements that reflect the time that electronic orders and backorders would take considering a given network infrastructure. These measurements would then be passed to the business process model in order to observe the effects they would have on the behaviour of the processes. The network model needs to know particular details about the information contained in an order and a backorder. When collecting the data needed to represent these entities, some problems were identified. For instance, data distributions required to represent the dynamic behaviour of the computer network model were not available because there was no prior network infrastructure to obtain these measurements from. This information, however, had already been collected in the Business Process Data Collection step, and thus it was used in the network model.

Another problem found was the lack of information available about order and backorder details. In order to create a traffic flow between the computer network nodes, it is necessary to know the size (in bytes) of an order and backorder. This figure depends strongly on the number of items requested in each order and other information contained in an order. Because the collection of data was performed before by the organisations with the intention of creating only business process models, this information was not collected and thus was not available. It was thought that this data could be estimated measuring a file that contains, in general terms, the information found in an order. The difference between the size of a real order and our estimate should not affect the network model significantly. Similarly, it was observed that an order and backorder contain very similar information. The network model is not concerned with the information conveyed in

the order but the quantity of data transmitted. Therefore, it was decided that a backorder was identical in size than an order.

Computer Network Model Translation

After deliberating about the computer network infrastructure needed for the development of the EDI system, it was decided that it should consist of a computer for Org-A warehouse (server), a computer to take orders in Org-A, a computer for Org-B (Server), a computer to take orders in Org-B, and a connection between Org-A and Org-B (see Figure 12). The way the network model was design is described as follows.

Network infrastructure Design.

Due to Org-A security policies, it was required that Org-A should keep the customer database on their premises. Consequently, a server was assigned to Org-A as can be seen in Figure 12. Orders are received by Org-A and Org-B, hence two clients were included in the model. One client for Org-A and one for Org-B (PC-A and PC-T respectively in Figure 12). It was agreed that Org-B should maintain an inventory database. Therefore, a Host for Org-B was added to the model. To link both hosts' and clients' PCs in their respective sites, a Ethernet Local Area Network (LAN) was proposed (Org-A is A-Eth and Org-B is T-Eth in Figure 12). Ethernet is one of the most common LAN network topologies and its characteristics were sufficient to support the new IS. Finally, To link Org-A's and Org-B's LANs a modem was assigned. The selection of the modem was because a) the number of transactions between both companies is relatively low (20 orders per day in total), and b) a modem is economical and it is believed it can deal with the network traffic load produced by 20 transactions a day.

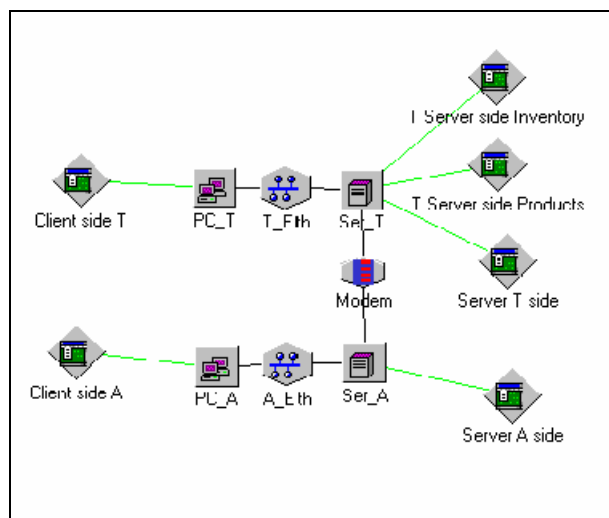

Figure 12 CNS model

Modelling Software Applications

COMNET III has the ability to generate software applications that model the traffic flow generated by a given IS. A software application is composed of a series of transactions between computer nodes. Each transaction is then passed to the network as packets, which are represented in bytes. An application, then, can be seen as the number of transactions produced by a given node within the network. A session, in COMNET III, is the total of transactions made by both clients and hosts. In our example a session will represent the transactions made between the network nodes when an order is placed. Figure 13 shows that Org-A and Org-B clients have their software applications. Since both clients are used to placing orders, both software applications contain the same type and number of transactions (see Figure 13).

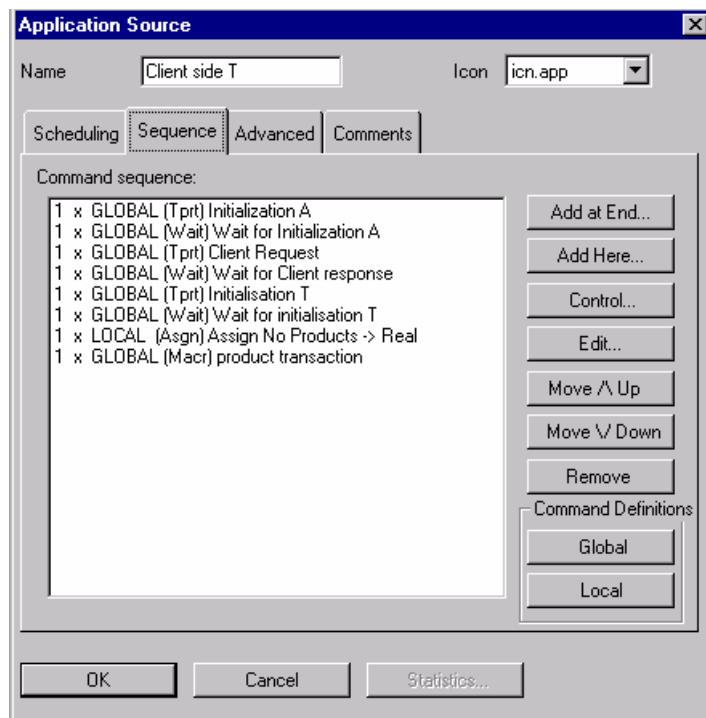

Figure 13 Application Source Client Side

One problem that emerged when designing client software applications was that the number of products that could be requested in each order was not available from the data collection. This number is important since the size in bytes of each order depends on the number of products that are requested in each order. In order to continue with the exercise it was decided to test the approach with a mean number of items requested in an order as a Normal distribution of 7 with standard deviation of 1. Because an order cannot have negative or fractional items, the commands were set in a way that the distribution will always return a positive and an integer number. This would allow us to investigate the

impact that these figures may have on the traffic network, and in case of being significant, collect data closer to the actual. On the other side of the equation, we have the host applications. A client application needs to communicate with Org-A client database to verify client details and then with Org-B's inventory and products database to place an order. Therefore, Org-A and Org-B also have their corresponding software applications in each of their hosts. Each of the software applications contains different transactions because clients request different information from them. Figure 14 shows as an example the transactions made in Org-B's host that holds the inventory database.

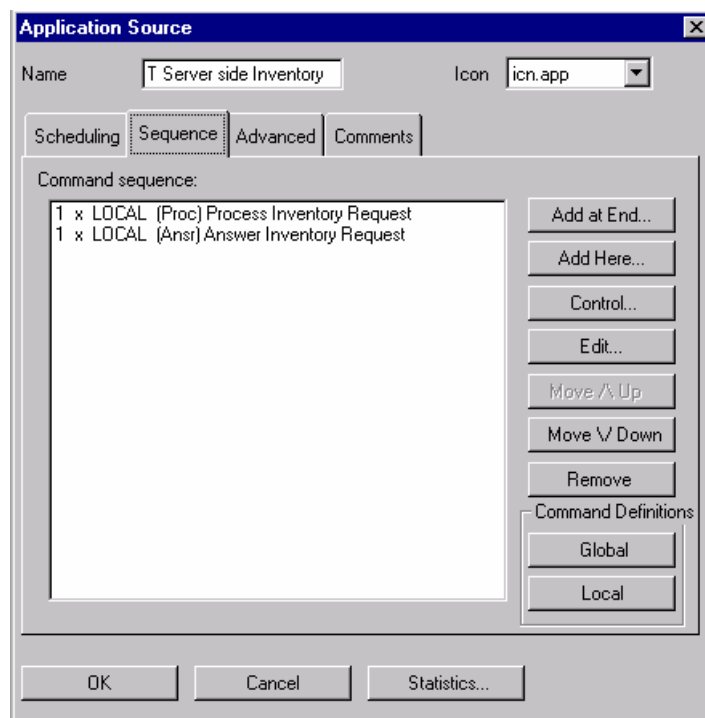

Figure 14 Server Software Application

The following step after both network infrastructure and software applications were designed and modelled was to verify the correctness of the model.

Computer Network Verification and Validation

To verify that the model was correct, the animation facilities offered by COMNET III were used. Because the network proposed was completely new, there was no data available to compare with and validation could not be performed using comparison techniques. The major goal of the ASSESS-IT approach, however, is to investigate the way two models, business process and computer network, could interchange data in order to predict the impact that IT may have on BP. Therefore, despite the fact that validation of the computer network model should be performed in normal circumstances, for the purposes of the

ASSESS-IT approach, it was assumed that the outcome of the CN model would not affect the integration process and hence the validation step for the network model was skipped.

3.6 Chapter Three: Summary and Conclusions

The literature review performed in Chapter Two provided evidence that discrete-event simulation techniques, in particular BPS and CNS, could be used in combination to depict the impact that a proposed IT infrastructure (IS and CN) may have on the business processes. To this end, this chapter found that the simulation steps proposed by Banks et al. (2000) could be used as the basis to propose a simulation framework to depict BP and IT performance. Because the steps proposed by Banks et al (2000) aim to design a single simulation model whereas this research aims to develop two simulation models, BP and CN, the ASSESS-IT framework proposed some changes. In doing so the new framework provides guidance to coordinate the design of BPS and CNS models and to share information between them so they can reflect the impact that the insertion of new IT may have on BP and vice versa. The changes proposed in the ASSESS-IT framework aimed to achieve the following objectives:

1. To coordinate the design of BP and IT so the corresponding models (BPS and CNS) include both BP and IT views. This done by joining *Problem Formulation* and *Setting of Objectives and Overall Project Plan* for both BP and CN models. Similarly a new step, *BP/IT Model Conceptualisation*, is introduced so it ensures that the design of both BP and IT issues are included in both BP and IT models.
2. To specify how and where the results from the CNS model can be used in the BPS model (and vice versa) so changes in one model are reflected in the other. A new step, *Interchange Models Data*, is introduced so information between BP and IT models can be shared.
3. To specify where possible iteration cycles between model results and model experimentation will be needed. By introducing a new decision step, *Changes to IT?*, the ASSESS-IT framework aims to show both BP and IT modellers the steps to follow after experimentation, considering the results obtained from previous steps.

During the design of process and computer network models, some interesting issues arose. First, it was observed that some entities needed to depict the business process model were also used in the computer network model, though at a different level of abstraction. In the case study, orders and backorders were the entities that were needed

at the business process model. These entities were also needed to represent the computer network traffic flow. The difference, however, is that the business process uses the order as a whole entity, whereas the computer network model needs to know the size (in bytes) of the information that will travel over the computer network infrastructure. Therefore, more details about the order (for example, the number of products contained in each order or number of characters used in each order) were needed.

Second, the review of IS approaches and modelling techniques suggested that some of the IS parameters that may affect the relationship between BP, IS and CN were non-functional requirements, in particular, performance requirements. During the application of the ASSESS-IT framework it was observed that the CNS model could provide IS performance measurements that relates only to time. That is, the CNS model reflects how changes to traffic network load and CN configuration may affect IS response time. When using the CNS results within the BPS model, however, it was observed that IS response time is not a significant factor that affects process performance. Moreover, BPS experiments provided evidence that a possible way to depict the impact that the IS may have on the BP is by portraying the functionality of the system as it evolves over time. These measurements, however, could not be obtained from the CNS or the BPS models. These issues suggested that the assumption that BPS and CNS models could be used to model the impact that IT may have on BP was not appropriate. The next chapter describes the problems arose during the development of BPS and CNS models, presents an analysis of the experiments and the results obtained after running process and network simulation models and reflects upon the effectiveness of the ASSESS-IT approach. In doing so, Chapter Four attempts to identify the limitations of this approach and how the experience from the ASSESS-IT could be used to identify other possible ways to depict the relationship between BP and IT.

4. Business Process and Information Technology Modelling: Problem Rediscovering.

4.1 Introduction

Chapter Three described a simulation framework, ASSESS-IT, that uses business process and computer network simulation techniques in an attempt to model the impact that information technology may have on business processes, using a case study to evaluate this framework. This chapter describes the development process of both business process and computer network models within the ASSESS-IT framework. It analyses the results obtained from both CNS and BPS models and looks at the relationship that the IS domain has with both business processes and computer networks. The analysis presented here will help to interpret the findings of the case study and to investigate the role of IS in the integration of BP and IT. The analysis of the BP and IS relationship will also help to evaluate whether the integration of computer network simulation models is appropriate to depict the interactions between business process and information technology. Finally, the knowledge gained from this reflection will help to propose a new theory to address the BP and IT design integration problem. Chapter Four is organised as follows. Section 4.2 presents a critical appraisal of the findings obtained from the development of the computer network simulation model and its results. Section 4.3 describes the development of the business process model and analyses the insights gained during this phase together with the results rendered by the BPS models runs. Considering the analysis presented in section 4.2, section 4.3 also evaluates whether the CNS model is necessary to be included in the ASSESS-IT approach and investigates which are the IT parameters that affect BP performance. Section 4.4 summarises the results obtained when developing CNS and BPS models, identifies that non-functional requirements, in particular performance requirements, are some parameters that affect IS performance and may affect business process performance. Section 4.5 summarises the results obtained from the ASSESS-IT framework and provides the foundation for a new framework to model performance requirements assessing in this way the impact that a new IS may have on the business processes.

4.2 ASSESS-IT: Computer Network Modelling Review

The ASSESS-IT framework proposes the development of two different models, one that reproduces the behaviour of the processes and other that depicts the behaviour of the information system and the network infrastructure that supports it. The initial thoughts of the approach were to develop a direct link between the computer network and the business process simulation model. The aim was to obtain from the network model the time that it would take to send an order and backorder, and use these figures in the process model so the impact of IT could be assessed. In practice, however, it was shown that producing a computer network model that depicts orders and backorders as a whole, like in the business process model, did not reflect reality. An order, from a computer network perspective, does not travel as a single entity but as a group of entities.

Before describing the differences between the entities in the business process and computer network models and for purposes of clarity, Record Entities (RE) will be used to refer to the entities used in the business process model as a whole (e.g. orders and backorders), and Field entities (FE) will be used to refer to the entities used in the computer network model and that grouped together form a FE (e.g. order number, client code, product code). Field entities have certain characteristics that may have an impact on the computer network design. For instance, they may take different routes and destinations. For example, to verify that a given client is on the records, the system uses one server (Org-A), and to check that there are products on stock the system uses another server (Org-B). Thus, field entities that are part of the same record entity may follow different paths and destinations. Another characteristic of field entities is that they may produce different operations in their destination network nodes. An IS usually transmits data (field entities in our case) to a determined host, remote or local, with the aim of performing a particular operation and obtaining a defined response (see Figure 15).

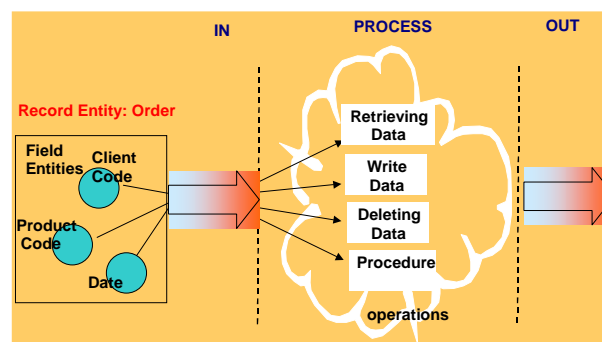

Figure 15 Record & Field Entities/Process Relationship from an IS Perspective

This *request-operation-response* sequence will be now named as a Transmission Operation (TO). The objectives of a transmission operation can be summarised in the following list:

- To *retrieve* data (e.g. a query)
- To *write* data (e.g. a database modify/insertion of a record)
- To delete data.
- To perform numeric or/and relational data operations. In order to avoid confusion with processes defined at the business process, I define *procedure* to this type of data operations.

It can be observed at this stage that in practice the ASSESS-IT approach did not match business process and computer network models directly. During the development of the case study it was observed that in order to reflect reality it was necessary to use IS as the intermediate layer to pass parameters between business process and computer network models (see Figure 16).

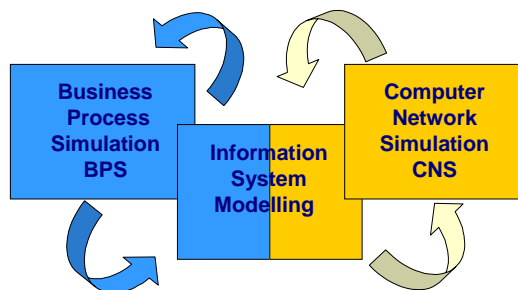

Figure 16 BP-IS-CN Model Integration

One of the most important issues raised with this new approach is that it identified that some entities used in the business process model (Record Entities) have certain links with those required in the computer network model (Field Entities) to represent software applications. The following subsection explains in more detail how software applications were built.

Modelling IS applications over the Computer Network

In order to model the network traffic produced by the information system in a more realistic manner it was necessary to identify the RE used in the information system. This information was necessary because in order to obtain the total time of an order or

backorder transmission, it is necessary to know the number of transmission operations performed for an order as well as the size (in bytes) of the information conveyed in each TO. Furthermore, it is also necessary to know what kind of operations are triggered by each TO and its duration. This information was not available and experience was used to estimate these figures. Transmission operations times, however, can normally be obtained from IS design models (e.g. collaboration diagrams and class diagrams) when they are available.

To represent the IS in the computer network there was additional information that was not considered in the ASSESS-IT approach but that was required to design the application sources. The following is a list of the information that was required and how this was obtained.

- *Application instances inter-arrival time.* Each time that an order is produced in the business process model it involves a number of transmission operations. Transmission operations need to be represented as application source instances in the CN model, which in turn, need to be fed with a data distribution. Therefore, the data distribution used to represent the arrival of orders in the business process model, were used to represent the data distribution in the application sources instances.
- *Information that affects the traffic generated by application sources.* Because application sources in the CN model aim to represent data operations in the IS, the design of the messages contained in the application sources must reproduce any frequency of data transmission or data message size variation. In the case study, for example, an order can be represented as a series of transmissions (one for each item in an order). Alternatively, if the order is sent all at once as a complete electronic document, the number of items may increase or reduce the size of the electronic document. Regardless of the case, the traffic network will be always affected. In our case study, these numbers were not collected. The data used in the model used estimates bearing in mind that the objective of the exercise was to demonstrate the effectiveness of the approach.

4.2.1 Computer Network Modelling Results

Once the computer network model was designed and verified a number of pilot runs were performed. The results showed that the time taken to complete an order was a maximum of 3.608 seconds and an average of 2.245 sec. The fact that the figure was significantly

low led us to rethink the way the model was designed. The model represented the traffic flow generated by a single IS which in turn produces on average an order every 24 minutes. Thus, the traffic flow was considerably low. It was thought that in reality the traffic in a computer network would be composed of a series of applications. The fact that a number of IS applications run over a computer network will increase the network traffic which in turn may have a greater effect on the transmission times in the IS. Therefore, it was decided to experiment with a series of different network traffic utilisation. The computer network model was run using varying degrees of network utilisation, which correspond to different levels of underlying IT capability to support the business process workload imposed on the network. The network response times were recorded for each run. The mean time taken for an *application instance* to be completed was recorded and the data was plotted against network utilisation (Figure 17).

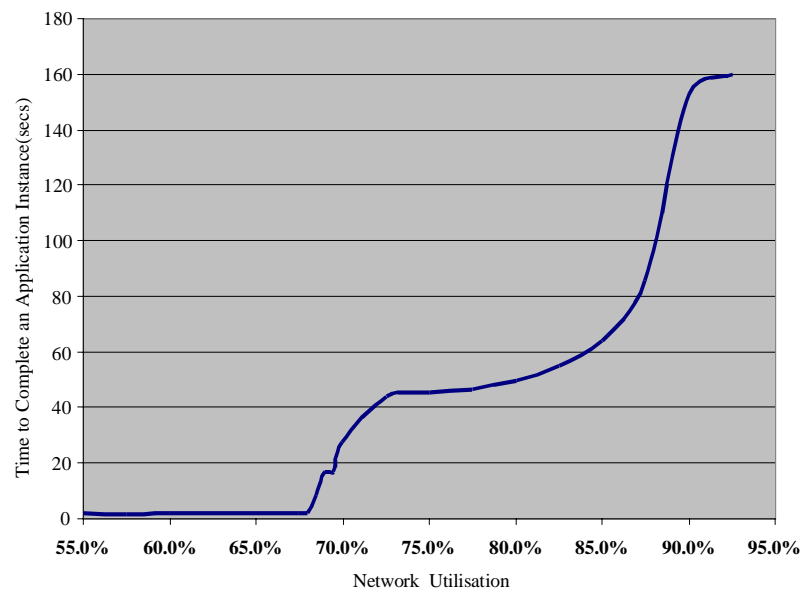

Figure 17 Application Instance Completion Time with Varying Degrees of Network Utilisation

From Figure 17 it can be seen that until network utilisation reaches a critical point (around 67%) the duration of the application instances are relatively steady and utilise the network for about 2 seconds per application instance; a response time that can be considered as acceptable from the end-user viewpoint. As network utilisation increases, however, we can observe a considerable increase in application instance completion times, rising to almost 45 seconds for high network workloads (67 to 79%), to 60 seconds for very high network workloads (79% to 85%), followed by an extremely sharp rise as utilisation rises to 92% (indicating network congestion at such high utilisation).

4.2.2 Computer Network Modelling Review: Conclusions

The results obtained from the network models using different levels of utilisation suggested that this could be a factor that may influence transmission times. The network utilisation needed to affect transmission times, however, was nearly 70%. Current network nodes have high processing power and can process huge amounts of data. Furthermore, CN technology also relies on a number of different routing techniques. Considering only these two facts, it is very unlikely, if not impossible, that current CN infrastructures can reach such levels of utilisation. Therefore, despite the fact the experiments performed showed that network utilisation can in theory affect IS transmission times, such levels are unlikely to be reached in reality.

The ASSESS-IT approach aimed to link business process, and computer network models. It was expected that the computer network model will render performance measurements of both the CN infrastructure and the IS used over the CN. This information will be used in the BPS model so changes to the IT would be reflected in the BP. The experiments showed that the CNS model provides performance measurements that are related to time. The way time is measured in the BP level and in the computer network level, though, differ substantially from each other. The experiments showed that the computer network may affect system performance in two different cases:

- a) If the IS is time-constrained. The computer network architecture and traffic flow may affect IS performance if the latter is bound to compute its results under a given time interval (usually specified under a few seconds).
- b) If the computer network works under high levels of network utilisation.

The analysis of the results, though, provided evidence that these cases are very unlikely to be experienced by the IT infrastructure used to support organisational processes. Analysing the first case, it was found that organisational systems are very unlikely to be time-constrained. The information systems used to support organisational processes are, according to O'Brien (1999), Transaction Processing Systems (TPS). TPS are mainly used to record and process data produced by business transactions. The results from the CNS model found that process and data transactions could be improved within a time scale of seconds. Subtle reductions of time, however, did not have a significant impact on the IS and BP performance. This is because the BPS model uses different time scales from those used in the CNS model. Many processes and activities in the BPS model are measured in terms of hours, days, and even months. Therefore, the addition or

subtraction of seconds in activities that lasts hours or days does not produce a significant difference. Furthermore, it was thought that the insertion of new technology could help to reduce process activities that were performed in terms of days in a matter of seconds or minutes. The results of the business process model, though, provided information that despite these activities being dramatically reduced, the overall process performance did not improve in a significant manner. It was found that because business processes are closely related, improvements in one activity may not necessarily improve the overall performance of the processes since other activities may be causing bottlenecks and hence reduce the impact of the insertion of IT. This issue will be explained in the BP modelling review section. In relation to the second case it was found that it would be very difficult to produce high levels of utilisation with the amounts of data used by a TPS. And, as previously discussed, current CN technology relies on hardware and software mechanisms to avoid such levels of utilisation.

The results from the CNS model showed that the CN model provides IS and CN performance measurements that are related to time. Time does not constrain, in a significant manner, the performance of the BP and the IS used to support business processes. This suggests that the use of a CNS model proposed in the ASSESS-IT approach may not be necessary to model the relationship between BP and IT. Furthermore, the development of the business process model, explained in the next section, gives more evidence that indicates that the ASSESS-IT framework should be modified, focusing on the relationship between business processes and information systems alone. The following section describes the process of design and development of the business process models and analyses the outcomes derived from this phase.

4.3 ASSESS-IT: Business Process Modelling Review

Despite the fact that the development of computer network models provided information that suggested that CN models should not be included in the ASSESS-IT approach, this information was not available until the final stages of the development of the business process model. Furthermore, the business process development phase provided more information that concur with the results obtained from the network models. This section describes the development of the business process and the insights that were gained during this phase.

As-Is Business Process Development

The development of business models was done in two phases. One, the development of the as-is model and two, the development of different business process scenarios (to-be models). The results from the as-is model are now described. The findings of the as-is business process confirmed the concerns of the companies that delivery times were much longer than the agreed targets. Even when no backorders were required, deliveries to Thessaloniki took 38 hours (target time was 24 hours), while deliveries to the rest of northern Greece took 60 hours (target time was 48 hours). Furthermore, when those orders that had items that were out of stock were included, the average time to deliver backorders rose to 82 hours. These figures suggested that the backorders were causing severe problems, so warranted further analysis.

Any order that required some out-of-stock products would effectively result in the order being divided into two separate orders; those products that were available, and those that were out-of-stock. The available products would be delivered as soon as possible, but the out-of stock products would need to be ordered from Org-A, who would then add them to the next scheduled warehouse replenishment delivery, resulting in long delays from the order being submitted and the particular products being delivered. Hence, times were recorded for backorders. When this figure was analysed it was found that the time taken from the backorder being generated to delivery accounted for 168 hours for Thessaloniki and 190 hours for northern Greece. Consequently, a series of business process scenarios were designed trying to address the problems found in the as-is model. The following subsection explains the experiments proposed.

To-Be Business Process Experimentation

The results rendered by the as-is model indicated that order and backorder processes had some limitations in terms of process design. Thus, before proposing an IT solution, it was decided to investigate different scenarios to improve these processes without using information technology. This would help to provide a better understanding of the way processes operate and to propose an IT solution that better fits the problems found in the business process model.

Three scenarios that would possibly alleviate the problems with backorders were considered. These are described in the following list.

1. Faxing backorders. Backorders were generated by Org-B and then held until the Friday evening, before being sent by post, which takes 2 days, to Org-A. For the purposes of analysis, the solution proposed was to fax the backorders to Org-A,

instead of sending them by post. It was assumed that by reducing the time the backorders spent in the mail system would have a significant impact on the delivery times.

2. Org-B sends the backorder list twice a week. Instead of waiting until Friday to send the backorder list, this is sent Tuesday and Friday evenings.
3. A final scenario that included the use of an EDI system was designed. The two companies share the same database to allow Org-A to have up-to-date information on stock levels at Org-B, and hence adjust replenishment shipments accordingly. The backorder list is generated automatically so Org-A knows at any moment the real-time stock levels in Org-B warehouse. It was thought that this would have an enormous impact on the delivery times, as a backorder that was generated on a Monday could now be transmitted immediately, rather than being delayed until the Friday before being forwarded.

4.3.1 To-Be Business Process Results

The results obtained from running scenario 1 were surprising. Although the time taken to send the back orders by mail was reduced from 2 days to a matter of minutes, the reduction in time taken to deliver the entire order was reduced by only 1 hour for orders and remained almost the same for backorders (times recorded for Thessaloniki). After a thorough analysis, it was found that this situation was due to two major reasons. Firstly, because of the organisation's policy, orders were retained until Friday afternoon to be faxed. Despite the fact orders arrived in a matter of minutes to Org-A, Org-A employees take about 8 hours to process an order list. Therefore, orders sent by fax on Friday afternoon did not have enough time to be processed on the same day and they have to wait until Monday. In the original scenario, orders took two days to arrive at its destination by normal mail. Considering that the mail works on Saturdays, the backorder list also arrived on Monday. Hence, both scenarios process the list almost at the same time. The second, and most important reason, is that there is only one employee working in the warehouse of Org-B, who, is busy 96.52% of his/her working time. Consequently, an extra experiment was performed adding one more warehouse employee, resulting in an 11 hours decrease for orders to Thessaloniki. Backorders, however, remained the same.

The second scenario was to schedule the replenishment shipments to be sent twice a week instead of once. This resulted in a reduction in delivery times for backorders, but it

was much smaller than anticipated (11 hours for back orders). This was due to the same problem identified in scenario 1 related to the warehouse employee. When the time was measured combining the scenarios of having two employees, faxing backorders twice a week, ordering times were recorded as 27.3 (11 hours reduction) and backorders as 127.6 (40 hours reduction).

Scenario 3 addressed the only real IT-based solution, in which, both companies share a database. Following the ASSESS-IT framework guidelines, transmission times (to send an electronic order) had to be obtained from the computer network model. Subsequently, transmission times were used in the business process model. The network reported that to send an electronic order could be done in less than 30 seconds (using a modem). Considering that this figure was relatively low (in comparison to the time it takes using normal mail) and that a backorder contains less information than an order, it was agreed to use 30 seconds as a transmission time for backorders. This information was also used in the business process model.

Sharing a database gives Org-A a better idea of the replenishment requirements of Org-B. The results did not show a noticeable reduction in the delivery times for the orders that had in-stock products, on the contrary, an increase of 29 hours was noticed for orders. The problem, as in the previous scenarios, was due to warehouse employee workload. It was reported that he/she was busy 99.06% of his/her working time. The increase of utilisation (more than 2%) was due to the fact he/she had to deal with a slightly higher number of backorders. Those products that required backorders, however, showed a substantial reduction of nearly 74 hours. This was mainly because the backorder list would no longer need to be created, as it would be generated in conjunction with the normal replenishment shipment. A final experiment was created which combined the results from scenario 3 with an extra warehouse employee. The results were as expected, since there was a reduction of 10 hours for orders and 82 for backorders. The times reached in this scenario were the best in comparison to the as-is scenario, though, they were still distant from Org-A and Org-B targets.

The results for the average delivery times of the entire order, and the average delivery time of backorders for each of the scenarios described before are shown in Figure 18.

4.3.2 Business Process Modelling Review: Conclusions

The results obtained from the experiments helped to identify preliminary advantages and limitations of the ASSESS-IT approach. For instance, the results from the business

process scenarios proposed in section 4.3 indicated that the majority of problems of Org-A and Org-B were related to business process design and not to information technology deficiencies. It was found that a major limitation of the way Org-B operates was related to the resources assigned to the different activities performed by Org-B. It was found that the only employee working in the warehouse of Org-B was busy 96.52% of his/her working time and that changes to the business process were constrained by this issue. Because this problem is related to the way processes operate, the insertion of IT does not provide any improvement in this respect, and the contrary may be true for some cases. It was observed that the warehouse employee needed to work more because the information system produced more workload in the activities in which this resource is used. When another warehouse employee was used in the model, many problems related to performance in the activities she/he was involved in were alleviated.

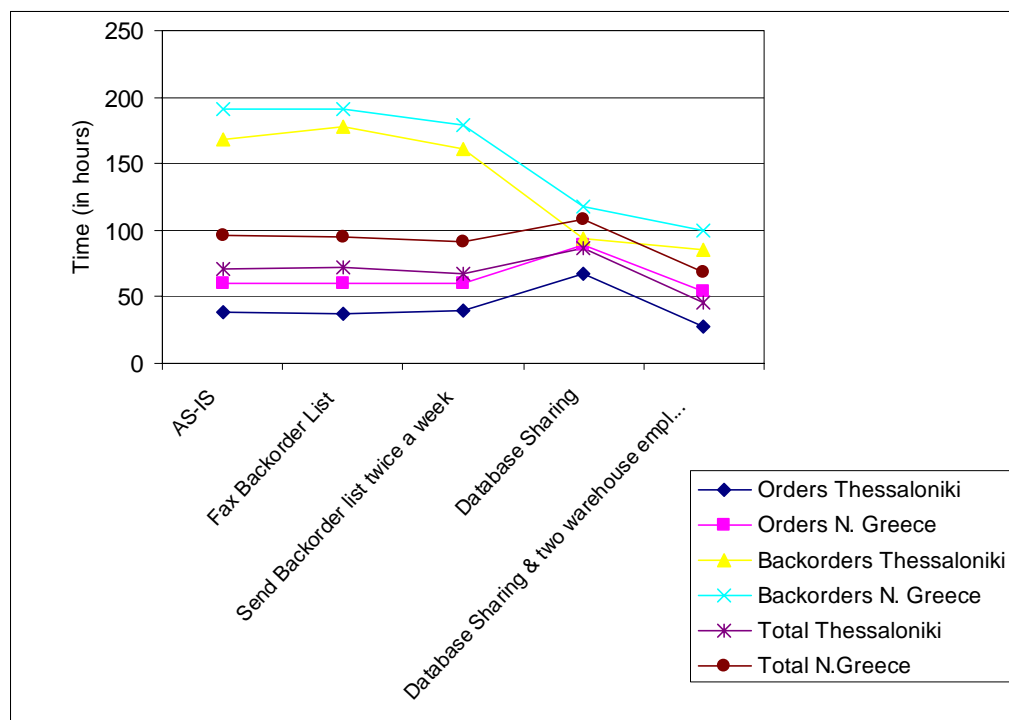

Figure 18 Delivery Times Scenarios

In order to avoid these problems, the experience gained during the BPS phase suggests that a thorough analysis of the BP is needed, and especially, it is necessary to identify:

- a) Business process limitations.
- b) Different business process alternatives.

c) System bottlenecks where IT-based solutions can be implemented.

In order to identify these three issues, performance measurements of the BP are needed. To this end, the experiments proved that BPS is able to provide this information.

The most important outcome of the experimentation with the to-be business process models is, perhaps, the identification of a system bottleneck, which in turn, is the key to depict the impact of the EDI system on the business processes. Preliminary research on business process methodologies suggested that applying IT with only the intention of automating business processes, and presumably improving performance, usually render disappointing results (Davenport, 1993, Kettinger et al., 1997, Hammer and Champy, 1993). The results of the experiments performed on the IT-based scenario described, corroborate this statement. It was demonstrated that despite the fact that the use of technology was introduced (database sharing) the results obtained from the models were far below the expectations of the organisations. The experiments performed, however, helped to identify that the backorder sub-process was a major bottleneck of the ordering process. Initial assumptions were that the insertion of an EDI system would reduce the backordering processing time. Nevertheless, the results showed that this was not the case. Despite the fact that transmission times were substantially reduced, the performance of the system was still not satisfactory.

To understand the reasons why the business process simulation exercise did not reflect what the EDI system should supposedly have delivered, we will analyse the EDI functionality in more detail. The EDI system was thought to function in the following way. It was assumed that information between both companies would now be shared. Therefore, the system in Org-A would now be able to know when the stock level of any given product was below the organisation's policy. When a given stock level is below its set figures to fulfil demand, the system would set an alarm to Org-A so they could be aware that a replenishment cargo was needed. Disregarding some exceptional cases (i.e. unexpected demand in a single product) it was expected that this new way of monitoring product stock levels would reduce the number of backorders since Org-A would have information about which products needed to be replenished before they were out of stock. The business process model, however, did not represent this kind of behaviour. As it is now, the business process model only reflects the time reduction due to the insertion of the EDI. To reproduce the effects that this new information system would have on the business processes it is necessary to know, rather than the reduction time, the number of backorders that would be reduced due to the use of the new IS. Bearing in mind that the

information system would more effectively control the inventory replenishment policies, which in turn would reduce the number of backorders produced on the system, a final experiment was proposed. The experiment consisted of decreasing the percentage of backorders produced in the business processes model (30%) to an estimated 5%. The experiment results proved that the overall ordering processing time could be reduced significantly if the percentage of backorders is reduced. The experiments showed an average of 31 hours for the delivering of orders and backorders to Thessaloniki, and 50 hours to northern Greece. These figures are closer to the targets set by both organisations.

4.4 The ASSESS-IT Framework: Lessons Learned

The results from the computer network-modelling phase showed that the impact that the computer network infrastructure may have on the information systems strongly depends on time. These results also demonstrated that due to current network technologies, the information systems that could suffer from changes to network architecture are those that depend on time. The type of systems that the ASSESS-IT approach aims to address, however, do not fit within this category. The experiments showed that changes to the network infrastructure and to other parameters (network traffic) did not have a considerable effect on IS performance, and consequently, did not affect the BP performance. Similar results were found in the business process-modelling phase. The results obtained in this phase showed that using IT to improve business response time does not necessarily improve process performance and might have negative results. The experiments did not show a significant improvement on business process performance despite the fact that the time was dramatically reduced for those activities that were changed due to the new IS. A deeper analysis of this situation suggested that the problem was due to the fact that the ASSESS-IT approach concentrated on depicting the way IT affects processing time, but not in the way IT affects process performance.

Business process modelling revealed that the time parameter in the CN had a minimal impact on overall process performance. The experiments showed, however, that there are other IS parameters that affect BP performance in a more significant manner. For example, it was proposed to use the EDI system to alleviate the problems found in the backordering process. Therefore, the IS was designed, among other things, to reduce the number of backorders. This information, though, could not be reflected in the business process model. The BP model was designed to represent the percentage of backorders statically (as a fixed number) and not dynamically. Reducing the backorders percentage

manually (from 30% to 5%) demonstrated that the reduction of backorders would also reduce the overall processing time. This figure was directly related to the way the IS would handle the backordering process.

Two conclusions can be obtained from the ASSESS-IT approach exercise.

1. The way the computer network infrastructure affects IS performance is represented as subtle changes of the IS response time in the CNS model. Subtle changes of IS response time, though, do not affect in a significant manner the overall business processes performance. Therefore, the use of a computer network model is, in the context of the ASSESS-IT approach, unnecessary.
2. The experimentation with different BP scenarios provided evidence that suggests that in order to portray the benefits that the use of an IS may bring to the business processes, it is necessary to obtain measurements of the way the IS behaves over time.

In order to provide a modelling approach that depicts the relationships and interactions between BP and IT, it is necessary to focus on the relationship between BP and IS alone. Furthermore, the insights gained from the experiments with different BP scenarios imply that the parameters that govern the relationship between business processes and information technology are not those that are related to time constraints but instead are those related to IS performance measurements. It was observed that time reduction on certain activities of the ordering process did not improve business process performance. On the other hand, IS performance measurements, such as the reduction of the number of backorders produced by the IS, improved the overall process performance.

These facts lead us to think that a new BP/IT integrated approach is desirable. According to the results and conclusions presented here, the approach should focus on the relationship between BP and IS, and more importantly, should depict IS behaviour measurements. In this direction, it is necessary to investigate about how to model IS performance. IS performance measurements, as reviewed in Chapter Two, are also known as information system's non-functional requirements. The requirements engineering review presented in Chapter Two indicates that despite the fact there is a large number of modelling techniques to portray IS requirements, most of them aim to depict functional requirements (for example enterprise modelling, data modelling, behavioural modelling, and domain modelling). Non-functional requirements, on the other hand, are not easy to represent in a measurable way, thus, a limited number of

techniques and approaches were found. Furthermore, the review identifies that from the NFR approaches found, most of them are used to elicit NFR and to match them against IS design. The approaches, however, are not useful to verify that those requirements meet the organisational goals.

These findings coincide with the results rendered by the ASSESS-IT approach since they highlighted the importance to portray the dynamic behaviour of the IS as it evolves over time. The problem, though, is that the ASSESS-IT approach, as it stands now, cannot provide such information. The following section presents the rationale for a new hypothesis that uses the ASSESS-IT framework results as the base to propose a new approach that can be used to identify NFR that affect IS performance and to model the behaviour of the IS and the BP as they evolve over time.

4.5 Chapter Four: Summary and Conclusions

The ASSESS-IT approach suggested that BP, IS, and CN are interrelated and that changes to IS or CN may affect BP performance. The experiments indicate, though, that the performance of the business process is affected by the performance of the information system that support those processes and not by the computer network infrastructure. It was observed that the way the computer network infrastructure affects business processes performance is in terms of time. The results showed that speeding up activities within processes with the aid of IT, however, did not improve business process performance in a significant manner. On the contrary, the opposite was true for some cases that reported an increase in BP lead times when the new IS was used.

One of the outcomes that was observed during the experimentation was that in order to model the impact that the introduction of a new CN infrastructure would have on the business processes, it was necessary to obtain IS performance measurements. It was detected that to predict the impact that the introduction of EDI may have on the business processes, it was necessary to identify the number of backorders that would be produced by the new information system. These figures can only be obtained by modelling the behaviour of the information system as it is used over time. Thus, in order to portray the benefits that use of an information systems brings to the business processes it is necessary to verify that the IS satisfy certain requirements, in particular non-functional requirements.

The requirements engineering domain assesses that information systems are not only determined by its functionality but also by the properties of the whole system such as

operational costs, performance, reliability, maintainability, portability, and many others. These *Non-functional Requirements* play a very important role during the software development process since they usually work as the selection criteria among a variety of decisions in the development process. Despite these facts, the IS community has found difficulty to represent non-functional requirements in a measurable way, a situation that impedes their proper analysis.

One reason non-functional requirements are difficult to analyse is due to the fact they have a global impact on the organisation and the system itself. Similarly, it is argued that to produce systems that meet non-functional requirements it is important to consider the organisation's characteristics.

The ASSESS-IT approach attempts to cover these problems using simulation techniques to represent the behaviour of the IT considering the organisational context (business process) in which they operate. One of the problems with the ASSESS-IT approach is that it considers the whole IT (IS and CN) and not the specific aspects of IT that affect IS and consequently BP performance. These aspects, according to the analysis of the results derived from the ASSESS-IT are likely to be IS non-functional requirements. The ASSESS-IT framework can be used as the basis to propose an approach to depict the way IS requirements may affect BP performance with the aid of simulation techniques. Using the ASSESS-IT results and experience, a new simulation framework to depict IS and BP interactions can be proposed. This framework can help to:

- a) **Identify non-functional requirements.** Non functional requirements are not always clearly defined by the users. For example, a non-functional requirement of the case study was to offer control of the inventory system in a more efficient manner. Further analysis using the ASSESS-IT approach indicated that the "*real*" requirement was to have as few backorders as possible. This was identified by experimenting with the model and isolating the parts of the system (processes) that were concerned with the backordering process.
- b) **Verify that the IS satisfies non-functional requirements.** Running the simulation model that depicts both IS and BP performance can be used to verify that the system satisfies user requirements.
- c) **Identify the variables that affect IS and/or BP performance.** Once a given non-functional requirement is identified, simulation can be used to isolate the process (together with the IS used to support this process) needed to satisfy this requirement.

Experimentation can be used to investigate the variables (e.g. resources, entities, etc.) that may affect IS and/or BP performance.

d) **Identify conflicts and tradeoffs between non-functional requirements.**

Experimentation can be used to identify the effects that changes in one user requirement may have on the others.

The following chapter uses the knowledge gained using the ASSESS-IT framework and proposes a new framework that aims to use simulation techniques to depict the dynamic behaviour of both information systems, namely performance requirements, and business processes.

5. Business Process and Information Systems Simulation: Re-hypothesis

5.1 Introduction

Chapter Four analysed the results obtained when applying the framework in a case study and reflected about the effectiveness of the ASSESS-IT framework. The analysis suggested that the use of a CN model in the framework was unnecessary since the results obtained from this model barely affect the performance measurements obtained from the BP model. Furthermore, the analysis of BP models indicate that IS performance measurements affected BP performance. Therefore, the relationship that was previously conceived as a three layered structure BP, IS, and CN, can be seen as the relationship between BP and IS. More importantly, the results showed that in order to portray the impact that the proposed IS may have on the business process it is necessary to portray IS behaviour. This chapter uses the knowledge gained from the experimentation of the ASSESS-IT framework to propose a new framework that uses BPS techniques to depict both BP and IS interactions. Chapter Five is divided in three major sections. Section 5.2 describes the rationale behind the new framework, namely BPISS. Section 5.3 describes each of the tiers in the BPISS framework. A summary of this chapter is presented in section 5.4.

5.2 The BPISS Framework

This chapter uses the experience gained during the implementation of the ASSESS-IT framework, and proposes an alternative approach to address the limitations found. The new framework, namely BPISS (Business Process and Information Systems Simulation), attempts to portray the behaviour of both IS and BP using discrete-event simulation techniques. The major objective of the BPISS is to provide guidelines to develop a simulation model that provide stochastic measurements of the way business process and information system behave, thus assessing the impact that IS may have on BP. To achieve this objective, the BPISS framework is divided into sixteen tiers. The first tier can be considered as a simulation study on its own where the major aim is to develop a model of the way current business processes operate (as-is BP model). The results from ASSESS-IT showed that the development of as-is BPS models could help to identify possible process limitations and areas of improvement, including possible IT solutions.

The BPS model derived from this tier will be used in subsequent tiers to a) identify process limitations, b) propose alternative BP and IT solutions, c) identify non-functional requirements, and d) validate the BPISS model. Tiers Two to Eight are the guidelines to develop an *as-is* BPISS model. The BPISS model considers the way the functionality of the IS supports business processes. Because this is an *as-is* model, the functionality of the *current* system should be portrayed. If the business processes are not supported by IT, the functionality of the manual system will be modelled instead. Tiers Nine to Twelve are the guidelines to develop the *to-be* BPISS model considering the functionality of the proposed IS solution together with the corresponding changes to the BP. Tiers Thirteen to Sixteen use Banks et al's (2000) simulation steps (steps nine to twelve) to conclude the simulation study. The tiers in the BPISS framework are depicted in Figure 19 and are fully described in the following section.

5.3 The BPISS Tiers

5.3.1 *As-is BPS Model Development Guidelines*

TIER ONE: AS-IS BPS MODEL DEVELOPMENT

Aim

To develop an *as-is* BPS model. The BPS model derived from this tier will be used in subsequent tiers to a) identify process limitations, b) propose alternative BP and IT solutions, c) identify non-functional requirements, and d) validate the BPS /ISS model.

Activities and Techniques

The simulation steps proposed by Banks et al. (2000) will be used in this step to develop the *as-is* BPS model. The simulation study proposed in this tier though, stops in the validation step because subsequent tiers of the BPISS framework involve the activities proposed in the remaining steps of Banks et al. framework.

Business process simulation is the modelling technique used to develop the *as-is* model proposed here. This research will use Simprocess ® to develop the BPS model because the programming capabilities found in this tool during the experimentation in the ASSESS-IT framework proved to be useful to achieve the aims pursued by the BPISS framework. The BPISS framework, though, is flexible in this respect so other simulation tools with similar capabilities can be used as long as the aims pursued in this tier are accomplished.

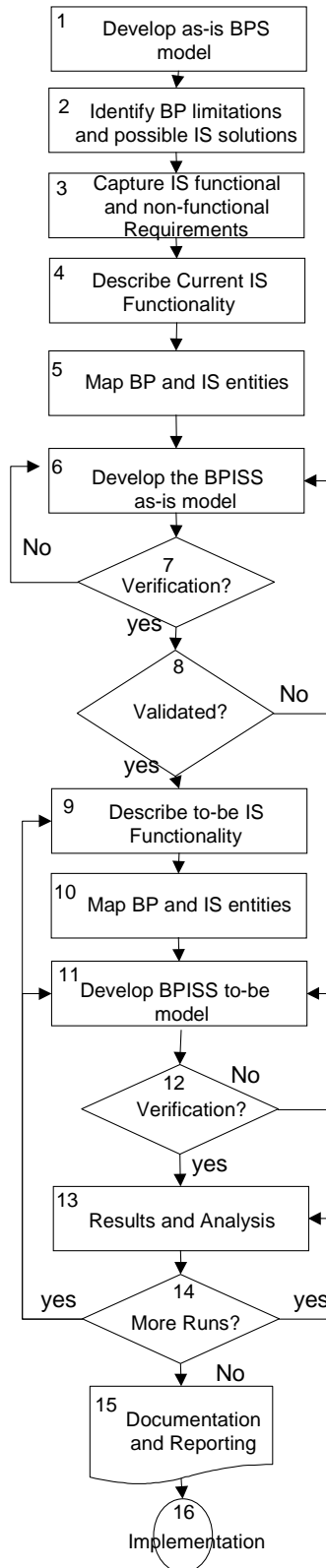

Figure 19 Tiers in the BPISS Framework

5.3.2 As-is BPISS Model Development Guidelines

TIER TWO: IDENTIFYING BP LIMITATIONS AND POSSIBLE IS SOLUTIONS

Aim

The as-is BPS model developed in Tier One will be used in this tier to: One, identify current process limitations. The ASSESS-IT framework proved that the insertion of IT in poorly-designed processes does not improve process performance. Thus, process design problems need to be overcome, whenever possible, before proposing IT-based solutions. Two, identify those processes where performance can be improved by the insertion of IS. ASSESS-IT also found that the analysis of process design problems also helped to identify those processes that can benefit from the use of a new IS. In cases where the organisation is already supported by an IS, this step will identify those processes where IS are currently used.

Activities and Techniques

To identify process limitations the performance measurements obtained from the BPS model should be assessed against organisational performance goals, which were previously captured in Tier One. In doing so, the modeller can identify those processes where performance measurements are not satisfactory. Experimentation, with different scenarios can be used to identify possible causes that produce low process performance, such as poor process design, inappropriate use of resources, and so on.

Once the proposed scenarios are tested, and process-related problems are identified, the insertion of IS should be considered next. To do so, IS and BP analysts should coordinate efforts so the functionality of the new IS addresses the limitations found in Tier One. Therefore, this tier also aims to provide a general description of what the proposed IS system is expected to do, in other words the functionality of the IS. In doing so, BP and IS modellers will be able to assess which processes can be benefited from the insertion of the IS and the ways it may improve process performance. The literature review found that there is a large number of successful IS modelling techniques that describe the functionality of the system; among these is the Unified Modelling Language (UML). Despite the fact that UML is not a modelling technique per se, this research found that some of the techniques derived from UML have been widely used to depict and capture IS functionality. Use case is a modelling technique proposed in many UML approaches that is used to document the behaviour of the system according to the user's perspectives. It is argued that use cases can be used, among other things, to capture user requirements, to

test the correctness of the system, and to coordinate IS analysis and design (Jacobson et al., 1992, Stevens and Pooley, 2000). The BPISS framework proposes the use of UML techniques, specifically use cases, to capture the functionality of the IS and to validate the BPISS model. The BPISS approach, though, recognises that other IS techniques can be used to portray IS functionality and advocates that the techniques used in this step should be chosen considering the modellers' and organisation's preferences.

TIER THREE: IDENTIFY AND CAPTURE IS NON-FUNCTIONAL REQUIREMENTS

Aim

Because the BPISS framework attempts to portray the way the functionality of the system will affect BP performance, this tier aims to identify and capture the expected performance of the information system. In Tier Two use case techniques were used to elicit and capture both, the functionality of the system and the way the system is expected to deliver that functionality (non-functional requirements). This tier aims to use the BPS model to identify other performance measurements that may have been overlooked in Tier Two.

Activities and Techniques

IS non-functional requirements are those that describe how well the system delivers the functional requirements, in other words, how the system should behave. The literature review in Chapter Two showed that professionals and academics advocate that non-functional requirements and organisational objectives are strongly related, therefore, non-functional requirements should always be captured considering the organisational context. Chapter Two reported, however, that current IS modelling techniques are mainly focused on depicting the functionality of the system and that non-functional requirements are not as well understood as other factors in IS. The BPISS attempts to depict a particular type of non-functional requirements, namely performance requirements. The BPISS framework will use the BPS model developed in Tier One to identify performance requirements. To achieve this aim, BP and IS modellers should analyse those processes and activities that were considered to be affected by the proposed IS, previously identified in Tier Two. A closer analysis of the behaviour of such processes and activities can provide useful information to identify other IS performance requirements that could have been overlooked using current IS modelling techniques. The Use Case model developed in Tier Two should be complemented with the findings of this tier.

TIER FOUR: DESCRIBE CURRENT IS FUNCTIONALITY

Aim

This tier aims to capture three major aspects of the current IS. One, to identify the overall workflow of the IS activities that are related to BP so this can be simulated in the as-is BPISS model. Two, to identify and understand how the data manipulated by the IS may affect BP entities, thus BP performance. Three, to identify the IS operations performed in during the process flow, so they can be represented in the BPISS model.

Activities and Techniques

Taking into account that UML techniques were used to capture user requirements, this tier advocates the use of three UML modelling techniques: Activity models to capture the system's flow and identify relationships between activities. Collaboration diagrams to identify the collaboration between IS components (objects) and the IS operations performed (messages). Finally, class models will be used to identify those classes that are related to the business entities. This research found that these techniques are useful to describe and document the functionality of the system for the purposes of this research, other techniques though, can be used instead. The choice of the modelling techniques to be used depends on the organisational policies and on the modeller's point of view.

TIER FIVE: MAP BP AND IS ENTITIES

Aim

Chapter Four defines two different types of entities for the ASSESS-IT framework. The first type is named Record Entities (RE) which are those entities found at the business level. RE usually represent objects that contain information and are used in the BP model to represent the process behaviour. For example, in the case study presented in Chapter Three, the record entities used in the BP model were orders, backorders, and partial orders. The second entity type defined in the ASSESS-IT framework is named Field Entities (FE). FE are the collection of entities that represent the information contained in a RE. The IS usually uses the information conveyed in these entities to perform part of its functionality. For example, in the case study mentioned earlier, the IS will use the information contained in the order, such as product type and number of items requested, to assess whether a backorder is required or not. Therefore, this tier aims to:

1. Identify all RE used in the business process level and map them to their corresponding FE.

2. Map the FE to the corresponding process/activity in the BP model.
3. Identify the operations performed during these activities and that affect RE or FE.

Activities and Techniques

In Tier Four of the BPISS framework a number of IS models that depict IS entities (classes or objects in UML) were produced. This tier will use those models to create a table, namely Record Entity/Field Entity Relationship (REFER), which relates the entities that are used in the BP model, their corresponding FE, the activities where FE are used to control the IS flow, and the operations performed when using these FE. The first step to build the REFER table is to identify RE and their corresponding FE. The class diagrams developed in Tier Four can be used to identify those classes that represent BP entities. Attributes of these classes represent the FE. Because not all of those attributes are used to control IS flow, the analyst should identify those attributes that are used to control flow and register them in the FE column. The activity diagrams developed in Tier Four will be used to identify which processes and/or activities use the FE identified before. The activities/processes are registered in the process/activity column. If an FE is used in more than one process/activity, this should be registered as a separate row. Finally, collaboration diagrams will be used to identify the IS operations that use or transform the FE in each of the activities. In doing so, each row of the REFER table provides information about a given FE, to which RE it is linked, in which activities it is involved, and which is the aim pursued by the IS when using the FE (IS operation). An example of a REFER table is shown below.

Record Entity	Field Entity	Process/Activity	Operations
Order	product_id	check warehouse activity	To identify the product requested
	product_quantity	check warehouse activity	To check product_stock stock levels against product_stock
	Product_stock	check warehouse activity	To check product_stock stock levels against product_stock

Table 6 A REFER Table Example

TIER SIX: DEVELOP THE AS-IS BPISS MODEL

Aim

This tier aims to develop the as-is BPISS model using the information collected in previous tiers, in particular, the information captured in the REFER table. Business process models usually do not include informational aspects of the organisation. For example, to obtain performance measurements of a backordering process, the modeller needs to know, amongst other important information, the number of backorders that will

be produced by the system. These figures are usually obtained during the data collection step (refer to Banks et al., 2000 for a complete description). To develop the as-is BPISS model the modeller needs to identify the RE and FE that are related to business performance and the business rules, including informational aspects, that may affect them. Following the same example of a backorder, the modeller needs to identify the activity or activities where a backorder is produced and the business rules that produce a backorder.

Activities and Techniques

The BPISS framework considers the IS (manual or automated) as a black box (see Figure 20). The relationship between BP and IS can be seen as relationships between input and output interfaces in each process and/or activity with the corresponding interfaces in the IS. For instance, the relationship between BP output-IS input interfaces is used to obtain information contained in BP entities (FEs) to perform the corresponding operations in the IS. Subsequently, the relationship between IS output-BP input interfaces is used to reflect the changes that the IS produces on the BP entities. It can be observed in Figure 20 that any input to the IS is reflected at any activity within all processes.

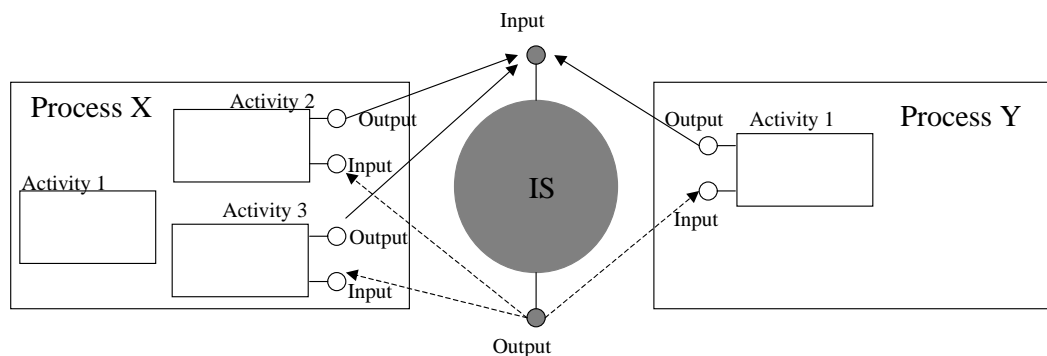

Figure 20 BP and IS Relationship

To develop the as-is BPISS model, this tier will modify the as-is BPS model developed in Tier One so it includes the information system behaviour. In doing so, it is assured that the components used in the as-is BPS model, such as data distributions, resources, and entities are consistent in both models. The development of the as-is BPISS model is divided in the following steps:

1. Represent FE in the RE. FE should be represented in the BPISS model as attributes of RE. This information can be obtained from the REFER table. The modeller should also identify other FE that are not linked to a specific RE. These FE should be

recognised in the REFER table as Models' FE and should be represented as Model's attributes in the BPISS model.

2. Program the functionality of the system. The modeller needs to insert programming code that represent the business conditions that produce changes to FE and RE together with the consequences of these changes. Simprocess provides the facility to add programming code to any activity and make changes to different model elements, including entities and attributes. Furthermore, the modeller can chose the simulation conditions when the code should be processed. For example, the code can be processed when an activity accepts an entity or when the latter is released from the activity. This feature adds the flexibility of choice to select the most suitable condition to run the code. To achieve this aim the modeller can use the information provided by the REFER tables, which indicate in which processes/activities the code should be inserted. In case that the information described in the REFER tables cannot provide enough details about the functionality of the system in a given activity, this information can be obtained analysing the activity and collaboration diagrams developed in Tier Four.

TIER SEVEN: VERIFY THE AS-IS BPISS MODEL

Aim

This tier aims to ensure that the computerised representation of the model is correct.

Activities and Techniques

The BPISS model is, per se, a simulation model. Thus, existing techniques to verify simulation models apply to the BPISS model. Because this research does not attempt to provide alternative verification techniques for simulation models, these are not specified in this tier. Detailed information about verification techniques can be found in Banks et al. (2000) and Law and Kelton (2000).

TIER EIGHT: VALIDATE THE AS-IS BPISS MODEL

Aim

This tier aims to ensure that the model is an accurate representation of the real system.

Activities and Techniques

Because the as-is BPISS model is based on the as-is BPS model developed in Tier One, and the latter has already been validated, this tier aims to validate the as-is BPISS model

against the as-is BPS model. To validate the as-is BPISS model, performance measurements from the as-is BPISS model are compared against those from the as-is BPS model. Amendments to the BPISS model should be done until the results of the as-is BPISS model match, in the best possible way, the results from the as-is BPS model. Due to the stochastic nature of both models, it is expected that some variation between these results will be found. These variations, though, should be minimal and should not jeopardise the validity of the as-is BPISS model.

5.3.3 To-be BPISS Model Development Guidelines

TIER NINE: DESCRIBE TO-BE IS FUNCTIONALITY

Aim

The aim of this tier is to describe the functionality of the proposed IS so this can be included in the as-is BPISS model.

Activities and Techniques

This tier will use the same approach and modelling techniques as those used to describe the current IS functionality in Tier Four. Furthermore, the models developed for the current IS can be used as the basis to create the new IS models. Thus, a new set of activity, collaboration, and class diagrams will be derived from this tier.

TIER TEN: MAP BP AND IS ENTITIES

Aim

This tier aims to update the REFER table obtained from Tier Five, so the new RE and FE that may be derived from the new IS are registered in the REFER table.

Activities and Techniques

Mapping BP and IS entities in this tier follows the same process as the one used to map these entities in the current model in Tier Five with the difference that this tier aims to map BP and IS entities of the proposed IS. BP entities are very unlikely to change, though the new IS may include new FE entities that need to be added to the REFER table. Therefore the same guidelines and modelling techniques used in Tier Five will be used in this tier to update the REFER table.

TIER ELEVEN: DEVELOP THE BPISS *TO-BE* MODEL

Aim

The following tier aims to programme the behaviour of the proposed IS in such a way that the model reflects any changes that the IS produces in the BP, specifically changes to FE and consequently their corresponding RE. The advantage of this model over an ordinary BPS model is that the BPISS model can assess the impact that the new IS may have on process performance. Furthermore, the modeller can also identify conflicts and tradeoffs between non-functional requirements and select the most suitable BP and IS scenario.

Activities and Techniques

The first step in developing the to-be BPISS model is to add/remove any RE or FE that may have changed from the as-is model (see Tier Six- Step 1). It is very unlikely that RE entities will change, however, the new functionality of the IS may have added other FE that need to be added or removed from the BPISS model.

It is expected that some activities in the business processes will change due to the insertion of the new IS. Therefore, the second step in this tier is to identify those processes and activities that need to be changed or removed from the BPISS model. Once changes are made in the BP level, the final step is to programme the functionality of the new IS. The same guidelines described in Tier Six-step 2 will be used to programme the new IS functionality with the difference that the new REFER table obtained from Tier Ten will be used.

TIER TWELVE: VERIFICATION?

Aim

This tier aims to ensure that the model is reflected accurately in its computerised representation.

Activities and Techniques

The BPISS model is, per se, a simulation model. Thus, existing techniques to verify simulation models apply to the BPISS model. The modeller, though, needs to take into account that the verification of the IS functionality needs to be assessed as well. Because this research does not attempt to provide alternative verification techniques for simulation models, these are not specified in this tier. Detailed information about verification techniques can be found in Banks et al. (2000) and Law and Kelton (2000).

TIER THIRTEEN: RESULT AND ANALYSIS

Aim

The results provided by the BPISS model need to be analysed in order to assess whether the proposed BP and IS design satisfies the organisational needs. An advantage of the BPISS model over traditional BPS models is that the results obtained from the former reflect the impact that the proposed IS has on the processes themselves. Another advantage is that the BPISS model can provide other stochastic information related to IS performance. Thus this tier aims to obtain information from the BPISS model to predict BP and IS performance and compare it against the organisational goals and the user requirements (non-functional requirements) identified in Tier Three.

Activities and Techniques

The BPISS model will provide two performance measurements, process performance and IS performance. Thus the analysis of these results should be performed by both BP and IS analyst. Depending on the results, the following tier indicates whether the proposed IS and BP need to be redesigned or if experimentation with other parameters or ranges of the existing ones, is considered necessary. The selection of the most appropriate technique for output analysis is out of the scope of this dissertation thus; it is not described here. The reader can find detailed information in relation to this topic in Banks et al. (2000) and Law and Kelton (2000).

TIER FOURTEEN: MORE RUNS?

Aim

According to the analysis of the results obtained from Tier Thirteen, the aims of this tier is twofold: One, to assess whether the redesign of IS and/or BP is needed; two to investigate the possibility of experimenting with different BP/IS scenarios.

Activities and Techniques

This tier analyses the results obtained from the BPISS model and compares them against the non-functional requirements identified in Tier Three assessing, in this way, whether the proposed BP and IS satisfy these requirements. If the results show that organisational goals and performance requirements are not met, the redesign of BP or IS functionality may be needed. If the redesign of BP is needed, the modeller should re-start the design

from Tier Eleven. If changes to the IS functionality is required the tiers should start from Tier Nine.

It is very likely that changes to input parameters may cause unexpected variation on the output performance measurements. Thus, the relationship between input and output parameters should be carefully analysed. The BPISS model is designed in a way that performance measurements of both BP and IS can be obtained. This can help to observe the impact that changes to IS input parameters may have on BP performance and vice versa. In this way, the experimentation with these parameters allows the modellers to *optimise* the model so the scenario that better suits the organisational needs can be identified.

TIERS FIFTEEN: DOCUMENTATION AND SIXTEEN: REPORTING AND IMPLEMENTATION

The major aim of the BPISS framework is to provide specific guidelines to create a simulation model that reflects both BP and IS performance. Therefore, it can be said that the contribution of the BPISS model ends after the experimentation tier is finished (Tier Fourteen). This research, though, recognises that it is important to include the documentation and reporting, and implementation tiers in the BPISS framework so these are not excluded from the simulation study. Because these tiers do not change from their analogue steps proposed by Banks et al's (2000), this research will use the guidelines provided in the documentation and reporting, and implementation steps provided in Banks et al.

5.4 Chapter Five: Summary and Conclusions

The results derived from the ASSESS-IT framework suggest that the relationship between BP and IT can be described as the relationship between business processes and the information system that support those processes, and not as a three layered structured (BP, IS and CN) as was thought in Chapter Three. Furthermore, the results from the ASSESS-IT framework found that in order to depict the interactions between BP and IS it is necessary to portray IS non-functional requirements, in particular IS performance requirements. This chapter proposed a new simulation framework, namely BPISS, to develop simulation models that depict business process and information systems performance. The BPISS framework can be summarised as follows.

1. Develop BPS model and identify possible IS scenarios. The framework uses a BPS model to represent current processes, identify process bottlenecks and propose possible IS solutions.
2. Identify IS functional and non-functional requirements. Once IS solutions are proposed, its functionality is described using current IS modelling techniques. Non-functional requirements are described and identified in two ways. First, *use cases* are used to document performance requirements. Second, the list is complemented using the BPS model to investigate other parameters that may affect BP performance and that are related to the proposed IS.
3. Develop the BPISS model. To develop a model that reflects both process and IS performance, the BPISS framework uses a preliminary model, namely as-is BPISS, to validate the model against the original BPS model. The as-is BPISS model aims to portray the way current business processes behave considering the changes that the informational aspects of the current system produce on the model. The existing system could be an IS or a manual system. Tier Five of the BPISS framework identifies those business entities, namely Record Entities (RE), that are used in the BP model and that are affected by the IS. To reflect the way the IS affects RE, Tier Five model decomposes the RE into Field Entities (FE), which in turn represent the information contained in the RE. These are registered in the REFER table. The REFER table should describe the information used by the system to trigger events or to produce changes on business entities. Based on the REFER table, a new model is created so it reflects the functionality of the new IS (the to-be BPISS model).

The BPISS framework was tested using the case study described in Chapter Three. Chapter Six describes, tier by tier, the way the way the BPISS was applied in the case study mentioned before, together with an analysis of the results rendered by the framework. A discussion of the advantages provided and limitations found during the development of the BPISS framework is also presented in Chapter Six.

6. Modelling Business Process and Information Systems: The BPISS Framework Assessment

6.1 Introduction

This chapter aims to achieve two major goals. First, to verify that the construction of a business process simulation model that portrays both BP and IS behaviour is possible. Second, to demonstrate that such models can provide useful information in relation to the way BP and IS relate. This research acknowledges that some limitations in terms of the simplicity of the case study can be identified, however, these can be justified considering (i) that the case study does not attempt to be exhaustive but to illustrate the accomplishment of the aims described before. (ii) A comprehensive case study would be too voluminous for a PhD dissertation. (iii) Such case study would be beyond the tolerable time limits of this dissertation.

Chapter Six is divided in Two major sections. Section 6.2 describes the application of each of the sixteen tiers of the BPISS framework in the case study described in Chapter Three. Section 6.3 presents a summary of Section 6.2 together with a discussion of the outcomes derived from this chapter.

6.2 Applying the BPISS Framework

6.2.1 As-is BPS Model Development Description

TIER ONE: DEVELOP AS-IS BPS MODEL

A BPS model of the current processes was developed during the application of the ASSESS-IT framework. Because this framework uses the same case study as the ASSESS-IT framework, the model developed in the latter will be used in this chapter to investigate BP limitations and possible IS solutions (Tier Two), to identify non-functional requirements (Tier Three), and to validate the BPISS model (Tier Thirteen).

6.2.2 As-is BPISS Model Development Description

TIER TWO: IDENTIFYING BP LIMITATIONS AND POSSIBLE IS SOLUTIONS

The experimentation tier in the ASSESS-IT framework provided a clear indication that order and backorder processes had some limitations in terms of process design. Consequently, three scenarios that would possibly alleviate the problems with backorders were considered. Because this tier aims to analyse process limitations before proposing IS solutions, scenario three (the EDI system) will be addressed after scenario one and two are thoroughly analysed. The following list describes scenarios one and two.

- Faxing backorders.
- Org-B sends the backorder list twice a week. Instead of waiting until Friday to send the backorder list, this is sent Tuesday and Friday evenings.

The results obtained from running scenario one indicated that the time taken to deliver the entire order was reduced by only 1 hour for orders and remained almost the same for backorders. It was found that this situation was due to two major reasons. Firstly, despite the fact faxing a backorder reduces dramatically the time between sending from Org-B and receiving them in Org-A, the overall performance does not reflect major changes. This is mainly due to the way current processes are designed (see Chapter Four). The most interesting outcome of this experiment was found when analysing Org-B warehouse employee working time. It was observed that the only employee working in Org-B warehouse is busy 96.52% of his/her working time. This situation had a knock-on effect on other activities. For example, the activities where the warehouse employee is involved, such as checking the inventory levels, creating backorders and packing the items, suffer major delays. Consequently, it was proposed to observe the effect produced by the insertion of a new warehouse employee. The results showed an 11 hours decrease in the orders lead-time.

The second scenario reported a reduction in delivery times for backorders (11 hours for backorders). Having realised that the warehouse employee was a problem in the previous experiment, it was decided to run the same experiment with two warehouse employees, and fax the backorders instead of using mail. The results reported an 11 hours reduction in order lead-time and 40 hours reduction in backorders lead-time. Thus, the experiments provided evidence that the use of technology (fax machine) and the proper design of the business

process could help the organisations to reach order and backorder delivery targets. Thus the proposal of an IS was viable at this stage.

After analysing previous process scenarios it was decided that the proposed IS should accomplish the aims described in the following list.

- The IS should automatically update inventory levels so a real time inventory level could be monitored by both organisations. To do so, it is necessary to have a record of the products requested in each order as well as the quantities requested for each product.
- The IS should automatically produce a backorder whenever a given product is out of stock.
- When a backorder is produced or the inventory level of a given product is below the figures established by the organisations, the IS should request the replenishment of this product.
- When a replenishment cargo is delivered, the inventory levels should be updated and reflected in real time.

Considering these aims, a use case diagram was produced. The use case diagram in this tier aims to describe the functionality of the system according to the user's perspective. Three major actors were identified in the system: Org-A employee, Org-B employee, and Org-B Warehouse employee. The first cut use case diagram is shown in Figure 21.

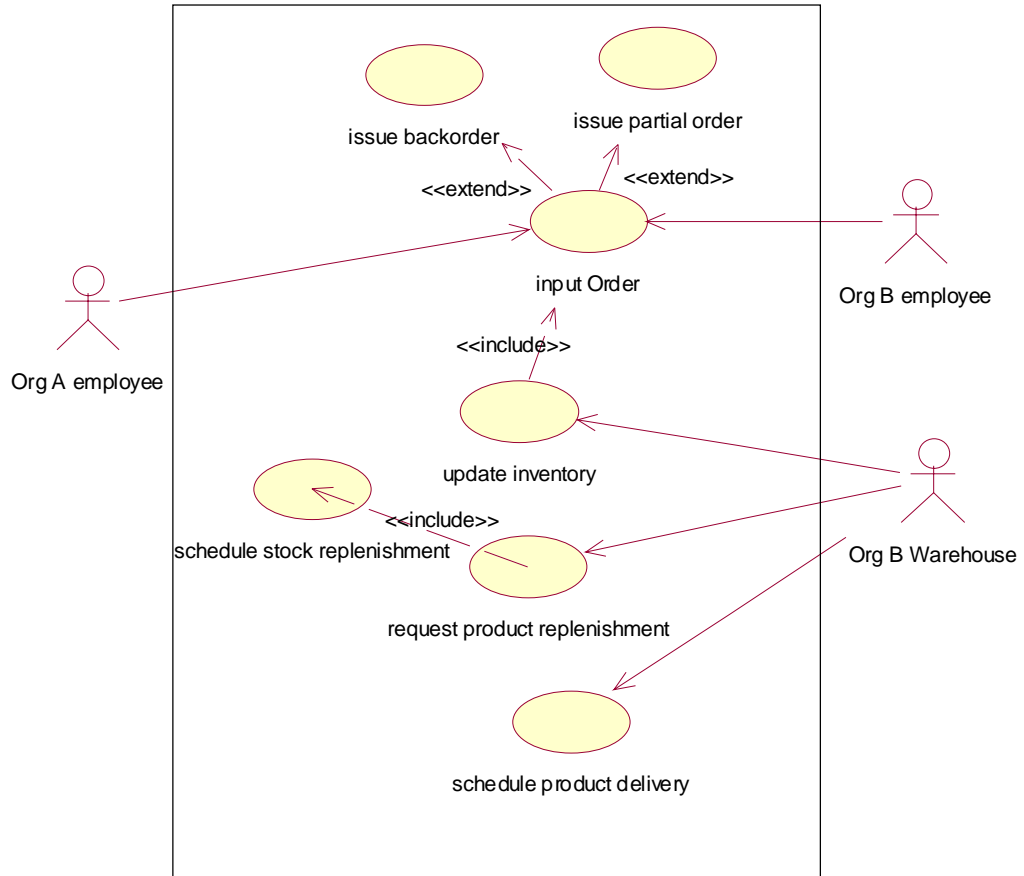

Figure 21 Use Case Diagram

TIER THREE: IDENTIFY AND CAPTURE IS NON-FUNCTIONAL REQUIREMENTS

In Tier Two one IS non-functional requirement related with performance measurements was identified. Org-A established that the overall delivery time, including backorders, should be 24 hours, for products delivered within the city of Thessaloniki, or within 48 hours for the rest of northern Greece. This means that it is expected that the introduction of the new IS would reduce current delivery times so they fit the requirements previously mentioned. A second performance requirement was identified during experimentation of the BPS model. It was detected that the backordering process was a major system bottleneck, and that delivery times depended on this process. It was demonstrated that when reducing the backorders percentage from 30% to 5%, the overall processing time was significantly reduced. Therefore, a performance requirement that was not identified before is related to the percentage of

backorders produced by the IS. This requirement is also related with delivery time requirement stated by the organisations, because if backorders are reduced it is expected that backorders lead-time will also be reduced. Current IS modelling techniques were able to describe the way the IS works. In this case, they describe the way the IS may help to reduce backorders. These techniques, however, cannot provide information related to the percentage of backorders that the system will produce. The as-is BPISS model aims to provide such information.

Tier Four: Describe Current IS Functionality

The use case diagram developed in Tier Two represents the functionality of the system. In this case the functionality of the current system is the same that the proposed system. The difference between current and future IS relies substantially in the way they delivered their functionality. One of the aims of the BPISS framework is to develop an as-is BPISS model that includes the informational aspects of the organisation. To this end, this tier aims to provide detailed information about the way the current system operates. Thus, a series of activity, collaboration, and class diagrams were produced. In conjunction, these diagrams represent the functionality of the current system.

Activity diagrams can represent information flow of a given process or activity of the system. Three activity diagrams were produced in this tier. One that represents the ordering process information flow, one that represents the information flow when a backorder is required, and one that represents the information flow when the stock of Org-B need to be replaced. These diagrams are shown next.

The "ordering process" activity diagram (Figure 22) starts when an order is issued ("key in order" activity). Then an Org-B employee checks that the products ordered are in stock ("check inventory" activity). Subsequently those products deducted from Org-B inventory ("update inventory" Activity) and their delivery is scheduled.

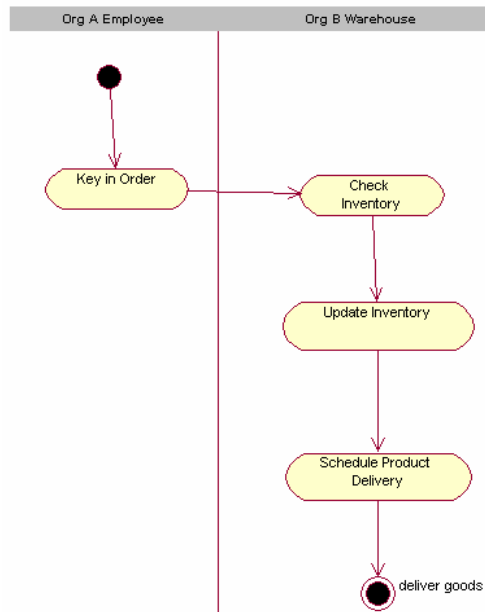

Figure 22 Ordering Process Activity Diagram

The "backordering process" activity diagram (Figure 23) shows that there are two options when a backorder is required. First, if some of the products requested are in stock, these are recorded as a partial order which in turn follows the path of a normal order. Second, for those products that are not in stock, a backorder is issued and the products are requested to Org-A. The process waits until Org-A schedules the stock replenishment. Then those products that were requested in a backorder are delivered.

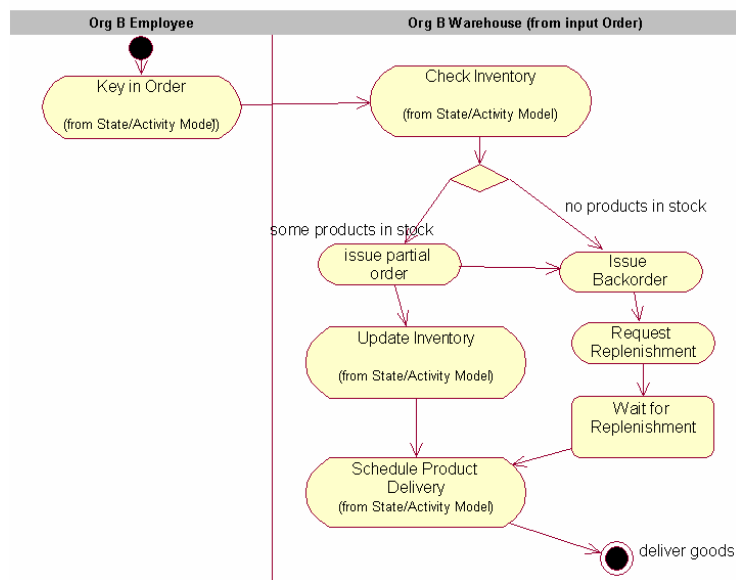

Figure 23 Backordering Process Activity Diagram

The "request product" activity diagram (Figure 24) shows the way products are requested from Org-A. the diagram shows that products wait until Friday to be requested. Org-A schedules the product replenishment to Org-B. When products arrive to Org-B, these are updated in Org-B database.

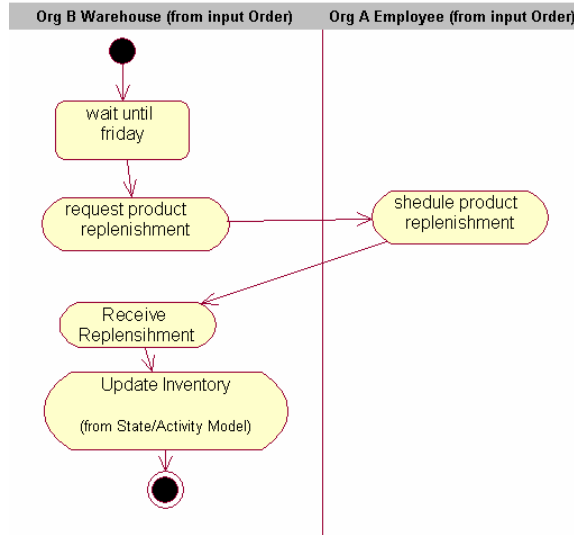

Figure 24 Request Product Replenishment Activity Diagram

Four Collaboration diagrams were used to describe the operations performed by the IS. The "ordering" collaboration diagram (Figure 25) shows the relationship between the objects used to request an order (order, product requested, stock, product, and order controller) and the messages passed between them.

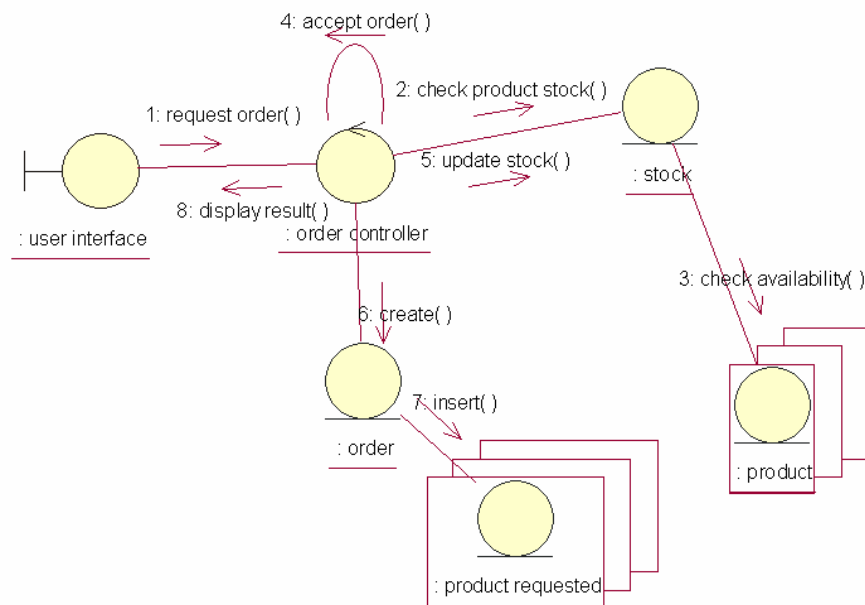

Figure 25 Ordering Collaboration Diagram

The "backordering" collaboration diagram (Figure 26) shows the relationship between the objects used to request a backorder (backorder, product requested, stock, product, and order controller) and the messages passed between them.

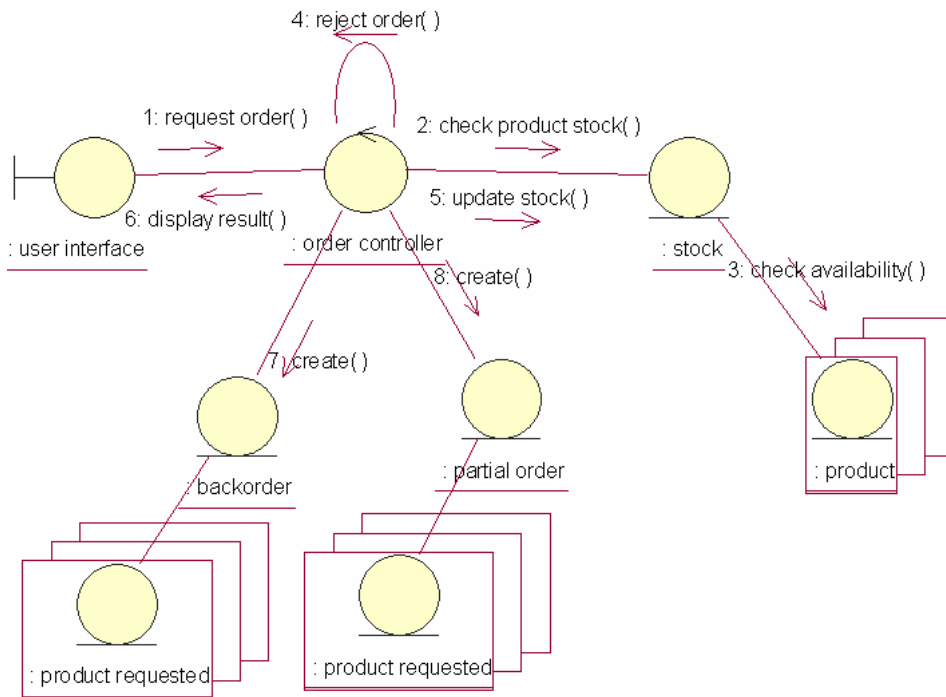

Figure 26 Backordering Collaboration Diagram

To replenish a product three objects are involved: replenishment controller, stock and product (see "product replenishment collaboration diagram" in Figure 27). This diagram also shows that this process is performed manually since a message from the user interface has to be passed to the replenishment controller to initiate the process.

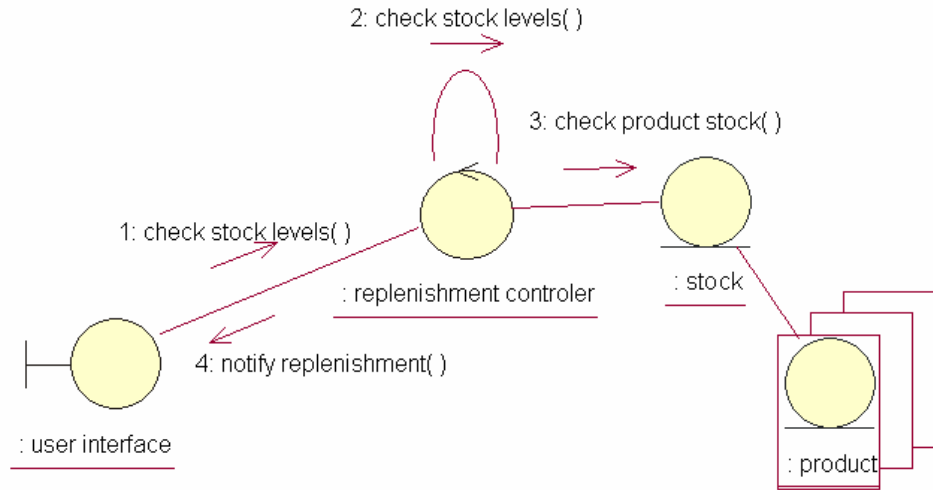

Figure 27 Product Replenishment Collaboration Diagram

The update inventory collaboration diagram (Figure 28) shows that the user manually updates product stock.

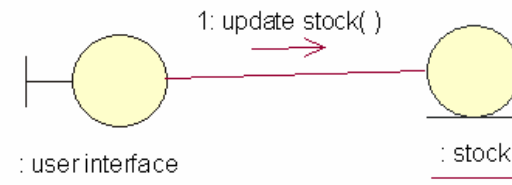

Figure 28 Update Inventory Collaboration Diagram

To identify the entities that are used by the IS, their attributes and relationships, a first cut class diagram was produced (Figure 29).

The information contained in the activity, collaboration and class diagrams shown before will be used to identify the RE and FE, the activities they are involved and the operations performed. This information will be recorded in a REFER table in Tier Five.

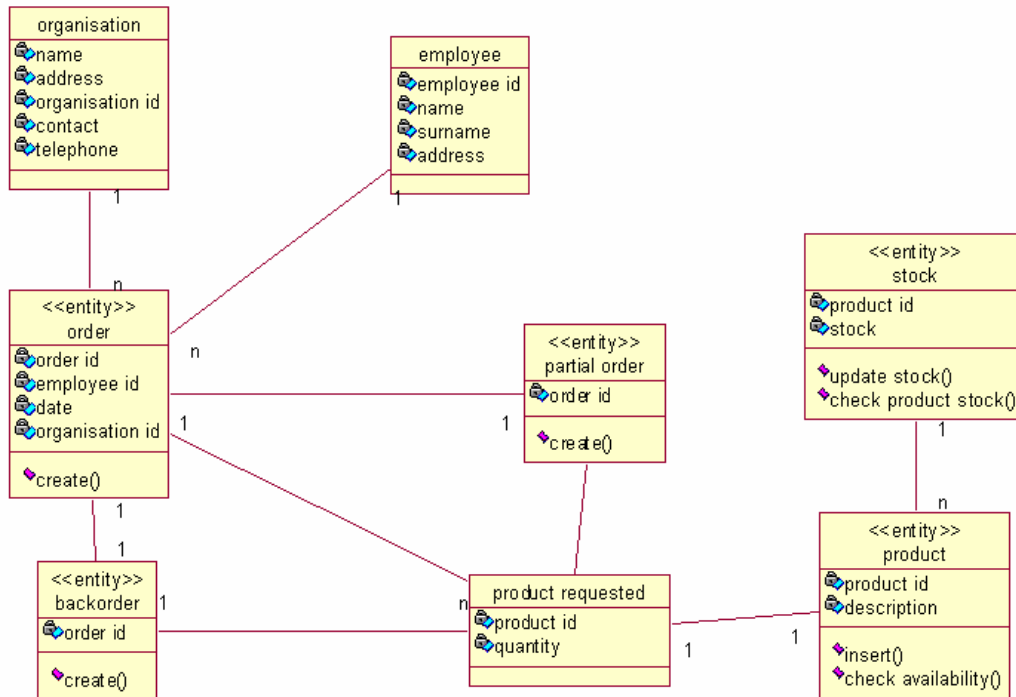

Figure 29 Class Diagram

TIER FIVE: MAP BP AND IS ENTITIES

This tier pursues three particular aims:

1. Identify all Record Entities (RE) used in the business process level and map them with their corresponding Field Entities (FE).
2. Map the FE with the corresponding process/activity in the BP model.
3. Identify the operations performed during these activities, which affect RE or FE.

This information can be obtained from the diagrams developed in Tier Four and from the BPS model. From the BPS model three RE were identified: orders, backorders, and partial orders. From the class diagram it can be observed that the attributes that are linked to an order are: order_id, employee_id, date, and organisation_id. Furthermore, it can be seen that the relationship between the entity named "product requested" with the order is many to one. This means that an order contains one or more products with their corresponding quantities. At this stage all these attributes are potential FE of the RE named order. In order to identify the attributes that are used to control IS flow and to perform their

corresponding IS operations, further analysis of the activity diagrams, collaboration diagrams and process model is needed.

From the activity and collaboration diagrams described in Tier Four, it was observed that order and backorder REs may affect IS performance. For instance, the products requested in each order and their quantities should be reflected on the inventory levels. When an order cannot be totally fulfilled, a backorder is produced. Low inventory levels and backorders indicate when a product needs replenishment. Therefore, the IS needs to keep track of the FE contained in orders and backorders that affect the inventory levels. The FE contained in an order are, amongst others, order identification number (order id), information about the client (organisation id) and salesman (employee id), and information about the products requested in each product (product identification number (product id) and product quantity (quantity)). It was observed that to update inventory levels the system should keep track of all the products requested in each order (product id) as well as their corresponding quantities (product quantity). Hence, the FE that are linked to an order and that are used to control information flow are: order id, product id, and product quantity. These FE must be recorded in the REFER table. The same procedure was performed to obtain the FEs linked to backorder and partial order REs.

In order to identify the activities and processes where RE and FE are used, further analysis to the BPS model was required. The activity where orders are produced and the products for each order are recorded is named "Create an Order" within the "Receive Order" process (see Figure 30).

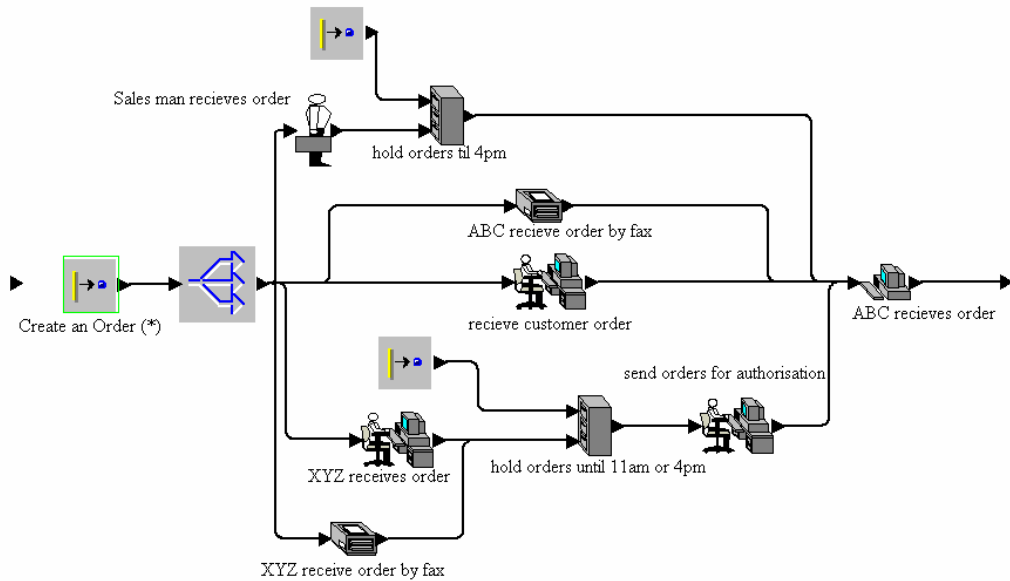

Figure 30 Receive Order Process

The activity where inventory levels are updated due to the request of an order is called "Check warehouse and reduce inventory levels". The activity where backorders are produced is called "A back order is required?" (see Figure 31).

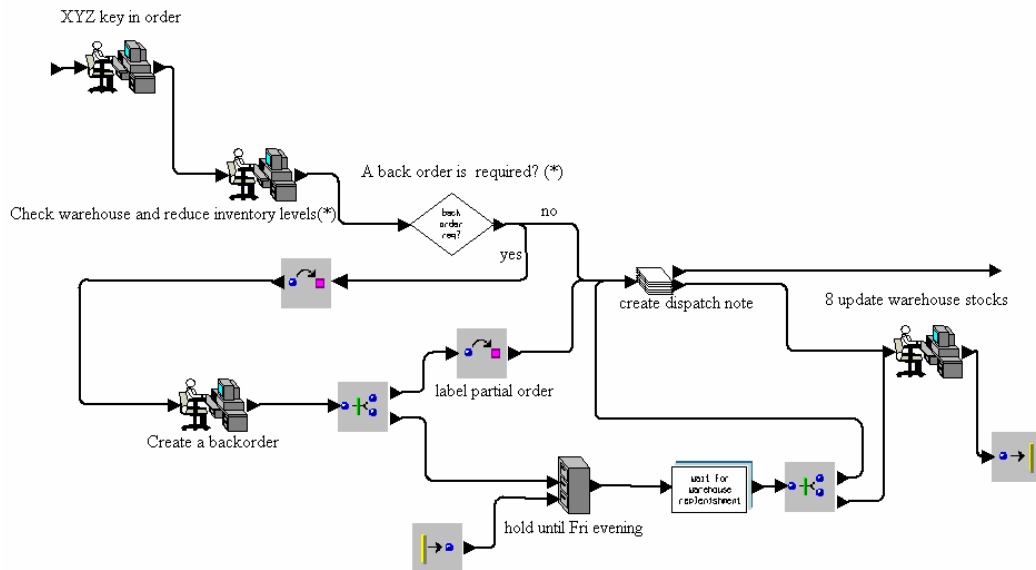

Figure 31 Check Inventory and Create Dispatch Notes Process (BPS Model)

The activities involved in the replenishment process are "update warehouse stock" and "wait for warehouse replenishment" sub-process as shown in Figure 31. Having this information, a final REFER table was produced (Table 7).

Record Entity	Field Entity	Process/Activity	Operations
Order	order_id	create an order	To keep track of the order
	product_id	check warehouse and reduce inventory levels	To identify the product requested
	product_quantity	check warehouse and reduce inventory levels	To check product_stock stock levels against product_stock
Backorder	backorder_id	a backorder is required?	To keep track of the backorder
	product_id	a backorder is required?	To identify the product that needs backorder
	product_quantity	a backorder is required?	To indicate the number of items that need to be requested
Partial Order	partial_order_id	label partial order	to keep track of the partial order
	product_id	label partial order	To identify the product requested
	product_quantity	label partial order	To indicate the number of items that need to be requested
Model	product_stock	check warehouse activity	To check product_stock stock levels against product_stock
	product_stock	update warehouse stock	To update product_stock stock levels
	product_stock	wait for warehouse replenishment	To schedule product replenishment

Table 7 Final REFER Table

TIER SIX: DEVELOP THE AS-IS BPISS MODEL

Before describing the process of building the as-is BPISS model a number of assumptions were made. In order to represent the number of orders and backorders produced by the system based on the demand of each product and in the inventory levels, it is necessary to identify the number of products offered by Org-A, the frequency of requesting a product, and the number of items ordered for each product. Because this information was not required in the original model, it was not collected and could not be obtained from the organisations. Considering that the aim of this exercise is to investigate the viability of constructing a simulation model that reflects the number of backorders based on the information carried in each order and in the inventory levels, it was assumed that the figures used to represent these results should not affect, in a significant manner, the simulation exercise and that other figures could be used to represent the 30% of backorders established in the as-is BPS model. Consequently, the following example was proposed.

1. The organisations would deal with a set of 10 different products.
2. The number of items that can be requested from each product was a uniform distribution from 1 to 10. This means that an order will have a maximum of 10 products with a range from 1 to 10 items that can be ordered from each product.

3. The stock for each product was set to 365 items.
4. The complete stock would be replaced every Friday at 10 am.

The following step to build a model that depicts IS performance is to create a new model that instead of using a fixed number to represent the number of backorders (30%), it reflects the number of backorders dynamically. That is, the model has to record those products that are requested in each order and deduct them from the inventory. Furthermore, in the event a product is not in stock a backorder has to be produced. After a week of processing orders and before the replenishment of the inventory, the model should to reflect 30% of backorders.

To do so it was necessary to:

1. Obtain product request frequency and product quantity. Considering that the inventory level for each product was set to 365, it was deduced that in order to have 70% of orders and 30% of backorders, it is necessary to request an average of 521.42 products per week before the replenishment is delivered ($365 \cdot 10/7$). The figure that is missing at this stage is the frequency of requesting a product. To simplify the model it was decided that each product would be requested with the same probability. The probability of a product X being ordered, given that 70% of the product ordered per week is 365 items and given that there are 500 orders per was found to be 81%.
2. Record the products requested in each order. The operations that represent the frequency in which a product is ordered and the quantities requested for each product were programmed within the "Create an Order" activity (see Figure 30). In order to record the products that were requested in each order together with the corresponding quantities some attributes were added to the order entity. An entity attribute is information linked to an entity instance and can be modified at run time. This means that each order would carry now information related to the order such as the order identification number, the number of products requested in each order, and a backorder flag that indicates if the order could not be fulfilled in its totality. Each time an order is produced a stochastic figure for products (from product 1 to product 10) and their corresponding quantities (from 1 to 10 items) are stored in the entity attributes.

3. Deduct the products requested in each order from the inventory. Simprocess software allows the modeller to insert global variables that are linked to the model and that can be modified at run time. 10 different model attributes were added to store initial stock levels. The inventory level of a given product X is updated whenever the product X is requested in an order. The corresponding programming code to the activity "Check warehouse and reduce inventory levels" (see Figure 31) was added so each time an order enters to this activity the inventory levels are updated. Each time a product is out of stock and cannot be fulfilled a flag that indicates that a backorder is needed is "turned on" and the stock levels are set to their corresponding negative levels.
4. Create a backorder. The backorder flag is used in the activity "A back order is required" (see Figure 31). When an order reaches this activity, its flag is "questioned". When the flag is set to "on" the order is tagged as a backorder and is separated from the orders. Orders and backorders follow different process paths as it shown in Figure 31.
5. Replenish the inventory on a weekly basis. Because this is the as-is BPISS model, the way the product stock level is replenished is exactly the same as in the original BPS model. Therefore, each week a lorry is sent and the stock levels of all products are updated to 365 items.

All these features were programmed within the BPS model. The following tier is to ensure that the as-is BPISS model is correct.

TIER SEVEN: VERIFY THE AS-IS BPISS MODEL

Debugging techniques were used to verify the correctness of the as-is BPISS model. The Simprocess modelling tool allows the modeller to display the status of any given model variable at any moment. This allowed the modellers to check that input and output variables in the activities under analysis were as expected.

TIER EIGHT: VALIDATE THE AS-IS BPISS MODEL

To validate the as-is BPISS model the number of orders and backorders produced by the original BPS model (ASSESS-IT as-is model) as well as the lead times for Thessaloniki and Northern Greece were compared to those

outputs produced by the as-is BPISS model. The results from both models are shown in Table 8.

Table 8 shows that despite the fact the number of backorders is set to 30% in the original BPS model, the results reflect that this model actually produces 25.90% of backorders. This is because the model has some activities that delay orders and backorders and once the model ends its simulation run-time, a number of orders and backorders are still being processed and are not reflected in the results. Therefore, instead of comparing the results of the as-is BPISS model against a 30%, the figure shown in Table 8 was used (25.9%).

	Original BPS	As-is BPISS	Difference	Difference (in %)
Orders (Thessaloniki) in hrs.	26.648	29.827	3.179	11.92960072
Orders (Northern Greece) in hrs.	48.088	46.148	-1.94	-4.034270504
Backorders (Thessaloniki) in hrs.	290.851	271.388	-19.463	-6.691742507
Backorders (Northern Greece) in hrs.	298.598	279.426	-19.172	-6.42067261
Total (Thessaloniki) in hrs.	76.99	92.92	15.93	20.69099883
Total (Northern Greece) in hrs.	98.046	98.077	0.031	0.031617812
Number of orders produced	2994.667	3085.667	91	3.038735192
Number of backorders produced	775.667	949.667	174	22.43230665
% of backorders	25.9016111	30.776717	4.875105898	

Table 8 as-is BPISS and Original BPS Model Results

The results in Table 8 indicate a difference of 4.8% between the percentage of backorders recorded from the original BPS model (ASSESS-IT as-is model) and from the as-is BPISS model. It was assumed that this was due to the randomness of both models. Thus, it was necessary to adjust the as-is BPISS model so it produces a percentage of backorders as close as possible to 25.9%. It was found that the results rendered when considering a probability to request a product of 72.3% were the closest to the original model, showing a minimum difference between the figures of 0.029 (see Table 9).

	Original BPS	As-is BPISS (Prob. 72.3%)	Difference	Difference (in %)
Orders (Thessaloniki) in hrs.	26.648	29.605	2.957	11.09651756
Orders (Northern Greece) in hrs.	48.088	44.344	-3.744	-7.785726169
Backorders (Thessaloniki) in hrs.	290.851	276.971	-13.88	-4.772202949
Backorders (Northern Greece) in hrs.	298.598	279.147	-19.451	-6.514109271
Total (Thessaloniki) in hrs.	76.99	87.136	10.146	13.17833485
Total (Northern Greece) in hrs.	98.046	97.407	-0.639	-0.6517349
Number of orders produced	2994.667	3097.333	102.666	3.428294365
Number of backorders produced	775.667	801.333	25.666	3.308894152
% of backorders	25.9016111	25.87170963	-0.029901468	

Table 9 as-is BPISS and Original BPS Model Results with Changes in Product Probability

From Table 9 we can observe that there are differences between some of the figures reported from both models. A significant difference was reported in orders lead-time (11.09%) and in the total time of orders and backorders

(13.17%), both related to Thessaloniki. After an analysis of the results, it was deduced that the increment in orders was due to the way the simulation tool operates. Although the distribution used to generate orders was not changed from the as-is BPISS model, the number of orders produced in the as-is BPISS model showed an increment of 3.42%. This is because when some changes are made in the model, the "seed" the tool uses to generate random numbers changes as well. The new seed caused a small variation in the number of orders produced by the system. Another figure that showed a significant difference was the lead-time to deliver the total of orders and backorders to Thessaloniki (13.17%). This increment is because in the as-is BPISS model more backorders are produced (3.3%). Backorders take more time than orders, hence the increment on total time. It was also reported that Thessaloniki processed slightly more backorders than Northern Greece, therefore, Thessaloniki showed an increment in total delivering lead-time, and Northern Greece remained almost the same. Once these issues were clarified, the as-is BPISS model was considered as valid.

6.2.3 To-be BPISS Model Development Description

TIER NINE: DESCRIBE TO-BE IS FUNCTIONALITY

The analysis from previous tiers suggested that many of the problems in the way the current system operates are related to the fact that both organisations do not count on an appropriate IT infrastructure. For example, one major problem is that the figures reported for the inventory levels in Org-A differ from those reported in Org-B. This situation produced a frequent lack of stock in Org-B's warehouse. Another problem is that the replenishment of products from Org-A to Org-B is not effective, since many products requested as backorders arrive later than the expected time. Therefore, the functionality of the new system aimed to address the problems related to backordering and product replenishment. Consequently, it was agreed that new IS should work in the following way.

- The IS should automatically update inventory levels so a real time inventory level could be monitored by both organisations.

- The IS should automatically produce a backorder whenever a given product is out of stock.
- When a backorder is produced or the inventory level of a given product is below the standards established by the organisations, the IS should automatically request the replenishment of this product.
- When a replenishment cargo is delivered, the inventory levels should be updated and reflected in real time.

Activity and collaboration diagrams were developed to portray the new IS functionality. Two Activity diagrams were changed from the previous model. The backordering activity diagram was changed so that when a backorder is required, it is verified that the products requested in the backorder are not in the process of being replenished. If this is the case, a new backorder is requested (see Figure 32); otherwise, those products that are in transit are not requested in the backorder.

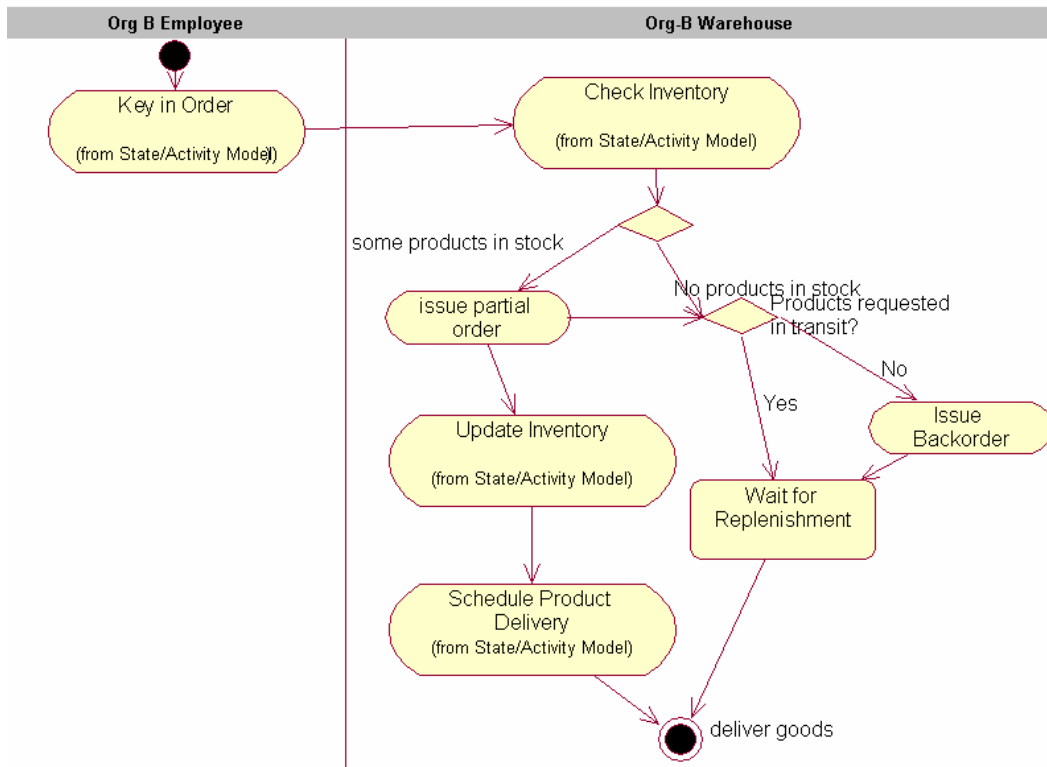

Figure 32 to-be Backordering Activity Diagram

Other changes were made to the "request product replenishment" diagram. The new diagram shows that the new system automatically checks product stock

levels and requests the replenishment whenever this is necessary (see Figure 33).

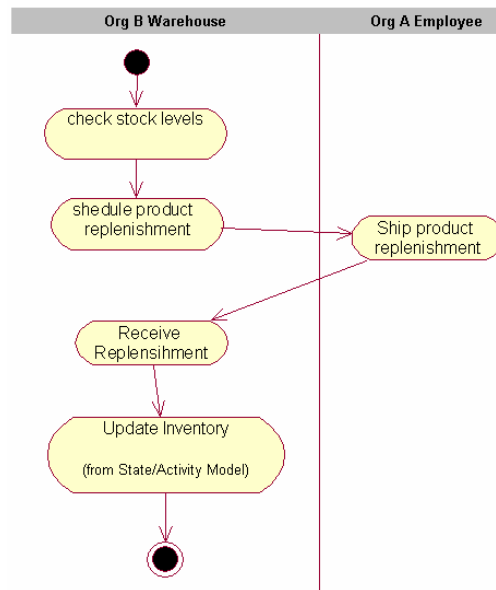

Figure 33 to-be Request Product Replenishment Diagram

Changes on the collaboration diagrams that are related to those activity diagrams were required. Hence, backordering and request replenishment collaboration diagrams were modified. It can be seen in Figure 34 that a new message in the order controller is added. This message checks that the products requested in a backorder are not in transit to be delivered.

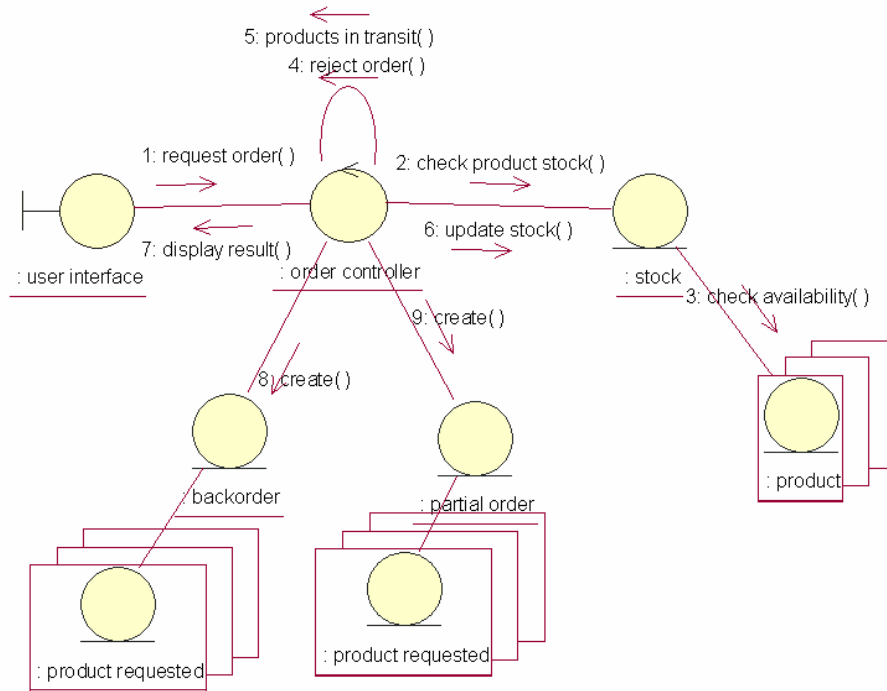

Figure 34 to-be Backordering Collaboration Diagram

The collaboration diagram in Figure 35 shows that the replenishment controller automatically checks stock levels and notifies when a product replenishment is needed.

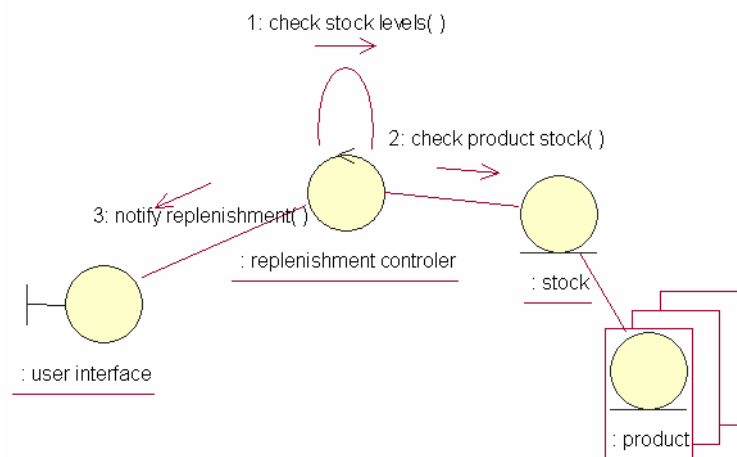

Figure 35 to-be Request Product Replenishment Collaboration Diagram

When comparing activity and collaboration diagrams of the current system with those of the proposed system it was observed that most of the problems of the current system are related to the way information is handled. It was found the activities performed in the current system were very similar to those derived

from the new IS. Both models differ mainly in the way the new system performs these activities and the way it handles and delivers information. The insertion of the IS, though, produced some changes to the way current business process operate, such as elimination of some activities and the automation of others. These changes will be described in Tier Eleven.

TIER TEN: MAP BP AND IS ENTITIES

The new IS design did not involve the insertion of new RE or FE, so the REFER table derived as the outcome of Tier Five remained the same. Therefore, this table will be used to develop the to-be BPISS model.

TIER ELEVEN: DEVELOP THE BPISS TO-BE MODEL

The to-be BPISS model should reflect the effects that the insertion of the new IS have on orders, backorders, and product stock levels. The new IS should monitor when product stock levels are below the goals set by the organisations, automatically produce a backorder when a product is out of stock, and automatically schedule the replenishment of stock and backorders whenever this is necessary. The system will also automate other the activities that were previously performed by hand. This means, that the time to perform these activities should be dramatically reduced. The following table is a list of the activities that were automated or replaced in the new IS.

Current System	Time	IS system	Time
Check warehouse	Nor(4,1) min.	Check warehouse	1 min.
Create backorder	1 min.	Automatically	None
Backorder sent on Fridays	-	Automatically	None
Prepare backorder list	10 min.	Automatically	None
Wait to schedule replenishment	Uni (2,8) hrs.	Automatically	None
Schedule replenishment	2 hrs.	Schedule replenishment	1 min.

Table 10 Activities Automated or Replaced in the BPISS Model

Figure 36 shows the way the "Check Inventory and Create Dispatch Notes" process was designed in the to-be BPISS model.

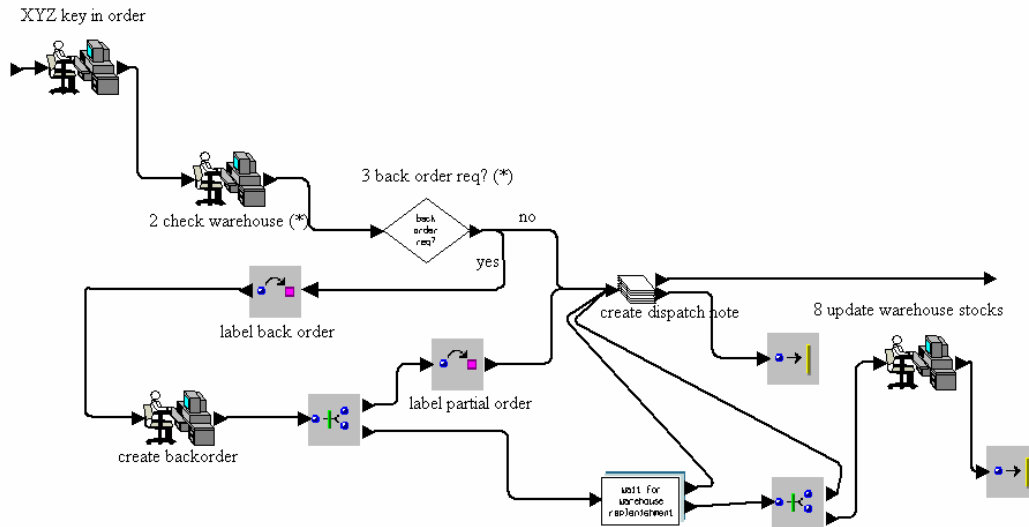

Figure 36 Check Inventory and Create Dispatch Notes Process (BPISS Model)

Major changes were required to update the inventory level. Figure 37 shows the "wait for warehouse replenishment" activities as they are in the as-is BPISS model.

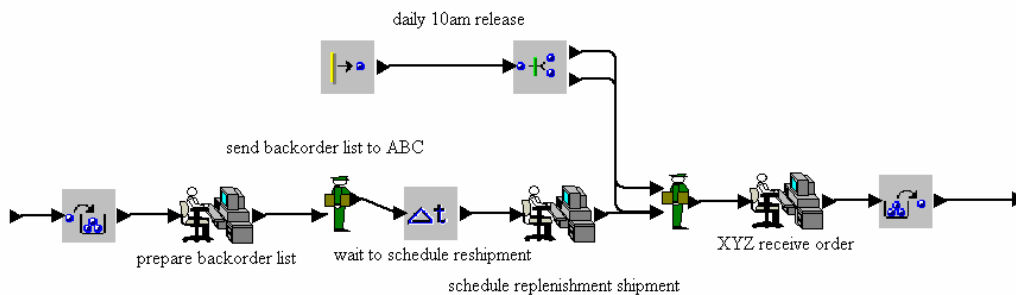

Figure 37 Wait for Warehouse Replenishment Activities (Original BPS)

Figure 38 shows the new "wait for warehouse replenishment" activities as they are in the to-be BPISS model. The reason changes were made to the activities in the "wait for warehouse replenishment" process is twofold. First, the system should trigger a replenishment cargo when the stock level of a given product is low and when a backorders is issued. Second, in the case a backorder contains products that are in transit to be replenished, these should not be requested again. The activity in Figure 38 named "Need Replenishment" evaluates this issue and separates those backorders that need to be replenished from those that do not. In the same figure, the activity named "Replenishment?" daily

evaluates the product stock level and requests a replenishment cargo whenever a given product stock is under the organisation's goals. The initial minimum stock level for each product was set to 10. Therefore, a lorry is sent only if a backorder is requested or if a product stock is less than 10.

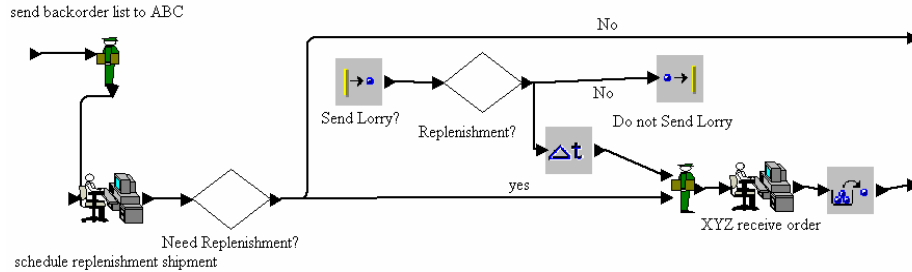

Figure 38 Wait for Warehouse Replenishment Activities (BPISS Model)

TIER TWELVE: VERIFICATION?

The same verification techniques used in Tier Seven were used to demonstrate the correctness of the to-be BPISS model. A difference between the verification process of this model and the model verified in Tier Seven is that the functionality of the IS had to be verified as well. To this end debugging techniques and activity and collaboration diagrams were used to corroborate that the system perform as established in these diagrams.

TIER THIRTEEN: RESULT AND ANALYSIS

The results of the BPISS model reported a significant reduction in the overall ordering and in particular in backordering lead-time. Table 11 shows that the backorder lead-time for both, Thessaloniki and Northern Greece were reduced in more than 80%.

	BPS Model	BPISS Model	Difference	Difference (in %)
Orders (Thessaloniki) in hrs.	29.605	23.659	-5.946	-20.0844452
Orders (Northern Greece) in hrs.	44.344	44.127	-0.217	-0.489355944
Backorders (Thessaloniki) in hrs.	276.971	39.998	-236.973	-85.55877691
Backorders (Northern Greece) in hrs.	279.147	46.498	-232.649	-83.34282654
Total (Thessaloniki) in hrs.	87.136	36.102	-51.034	-58.5682152
Total (Northern Greece) in hrs.	97.407	52.885	-44.522	-45.70718737
Number of orders produced	3097.333	3166	68.667	2.216971827
Number of backorders produced	801.333	1125.667	324.334	40.47430968
% of backorders	25.87170963	35.55486418	9.683154553	

Table 11 BPISS Model Results

These results, however, are still longer than the organisational targets. Total lead-time for Thessaloniki was set to 24 hrs whereas the BPISS model reported 36 hrs, a difference of 12 hrs. Northern Greece results reported 52 hrs which is

a difference of 4 hrs in respect to the target set (48 hrs). Despite the fact the results obtained did not meet the performance requirements established in Step Two, these were close to the targets set and provided confidence that experimentation with alternative scenarios could solve this problem.

An interesting observation in Table 11 is that the percentage of backorders produced by the BPISS model reported an increase of 9.6%, a situation that contradicts the assumptions made in Tier Three. A possible reason that may cause this situation is that the minimum product stock level agreed by the organisations (10 products) produces a greater number of backorders. This event, though, does not affect, in a significant manner, backorder lead-time because the new system schedules delivery times in a more accurate manner than the current system. This theory could be tested experimenting with alternative minimum stock level scenarios and observe the effect that this produces on the number of backorders and their lead times.

TIER FOURTEEN: MORE RUNS?

The results obtained in Tier Thirteen showed that a possible way of reducing backorders and consequently lead time is to increment the minimum stock level for each product. To find a good candidate for this figure, a file that reported the stock levels on a daily basis was produced and plotted. Figure 39 shows a section of the graphic.

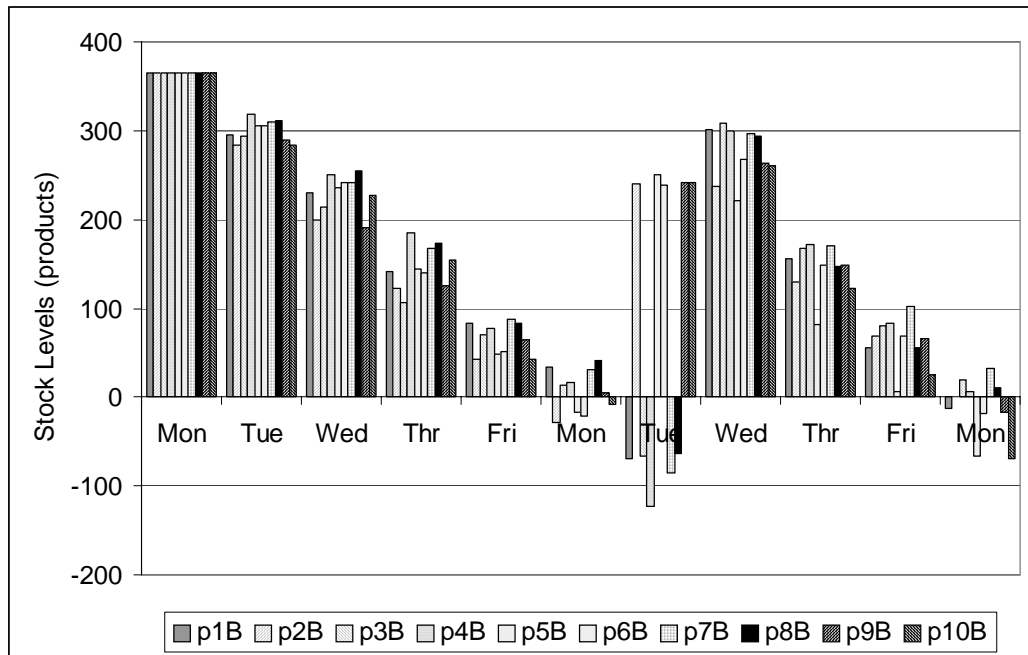

Figure 39 Daily Product Stock Level Reported by the BPISS Model

Figure 39 shows that the days stock levels need to be replenished and hence backorders are requested (negative figures in Figure 39) are the following days that any product stock level is below 100 products (second and third Monday). These results suggested that initial experiment should begin with a minimum stock level of 100 products. When the model was ran with the product stock level set to 100, the number of backorders was reduced by 5% in relation to the as-is model. Furthermore, Thessaloniki targets differ by 6 hrs and Northern Greece by only 2 hrs (see Table 12).

	BPS Model	BPISS Model	Difference	Difference (in %)
Orders (Thessaloniki) in hrs.	29.605	27.009	-2.596	-8.768789056
Orders (Northern Greece) in hrs.	44.344	47.718	3.374	7.608695652
Backorders (Thessaloniki) in hrs.	276.971	29.245	-247.726	-89.44113283
Backorders (Northern Greece) in hrs.	279.147	43.101	-236.046	-84.55974809
Total (Thessaloniki) in hrs.	87.136	30.196	-56.94	-65.3461256
Total (Northern Greece) in hrs.	97.407	49.96	-47.447	-48.71005164
Number of orders produced	3097.333	3180	82.667	2.668973598
Number of backorders produced	801.333	660.333	-141	-17.5956812
% of backorders	25.87170963	20.76518868	-5.10652095	

Table 12 BPISS Results with Minimum Stock Level of 100 Products

After experimenting with other possible stock level scenarios no greater improvement was shown. Thus, scenario with 100 minimum stock level was considered the most appropriate one.

The results from the to-be BPISS model and different scenarios demonstrated that the insertion of the new IS can improve BP performance. The BPISS model provided performance measurements of the IS that were reflected on BP performance. Furthermore, the BPISS model provided the means to observe the impact that changes to different IS parameters may have on BP performance and vice versa, allowing in this way to find the best BP-IS combination.

The experimentation with different scenarios showed that the relationship between BP and IS is complex and that changes to IS parameters may have unexpected consequences on the organisational goals. For example, the fact that the new IS automatically schedules product replenishment produces a stochastic number of journeys for the lorry that delivers those products. If the numbers of journeys are considerably more, the cost of this resource will also increase. Therefore, these figures had to be compared against organisational goals in order to assess whether this solution is cost effective. Otherwise, new performance goals had to be set and new BP and IS solutions had to be proposed aiming to achieve these goals.

TIERS FIFTEEN AND SIXTEEN

The following Tiers in the BPISS framework (Tiers Fifteen and Sixteen) involve documentation, reporting and implementation. This research aims to demonstrate that the development of simulation models that depict BP and IS performance is possible and that such models could render useful information to design BP and IS. Therefore, it was considered that documentation, reporting and implementation tiers are out of the scope of this research and are not included in this dissertation. Guidelines to achieve these tiers can be obtained from other simulation approaches such as Banks et al (2000) and Law and Kelton (2000).

The following section provides a summary of the contents of this chapter. It explains the transition from the ASSESS-IT framework to the BPISS framework, explains the BPISS model development process, and presents a summary of the results obtained from experimentation.

6.3 Chapter Six: Summary and Conclusions

The results obtained from the ASSESS-IT framework indicated that in order to portray the effects that the insertion of new IT may have on the business

processes it was necessary to look at the relationship between BP and IS. ASSESS-IT also showed that in order to depict this relationship, it was necessary to obtain performance measurements of the IS. Based on these results, a new simulation framework, namely BPISS, was proposed in this chapter. The BPISS framework aimed to develop models to depict both IS and BP behaviour. There are two major assumptions that represent the rationale behind the BPISS framework. First, the ASSESS-IT framework provided evidence that suggests that the relationship between BP and IS can be modelled by portraying IS performance measurements. To portray these performance measurements, though, they need to be clearly specified beforehand. The literature review in Chapter Two found that IS performance requirements are difficult to portray and cannot always be identified by current IS modelling techniques. ASSESS-IT demonstrated that the analysis of business process behaviour helped to detect other performance requirements that were overlooked by current IS modelling techniques. It was demonstrated that a thorough analysis of the way BP behaves provided valuable input in relation to the way the new IS should function. Hence, the BPISS framework proposes that capturing non-functional requirements could be complemented with the analysis of BP behaviour.

Second, ASSESS-IT showed that in order to portray the impact that IS may have on BP it is necessary to depict stochastic aspects of the IS. IS modelling techniques, though, are mainly static and do not provide the means to obtain stochastic measurements to portray IS behaviour. The BPISS framework identified that current BPS techniques could be used to address this issue. Furthermore, because the major aim of the BPISS framework is to depict the way IS behave within a given organisational context, it was thought that IS behaviour could be addressed using existing BPS models. Taking into account these assumptions, a simulation framework that depicts both BP and IS was proposed.

The BPISS framework proposes the development of three models, an ordinary BPS model, and as-is BPISS model and a to-be BPISS model. The as-is BPISS model represents the informational aspects of the system that trigger business process events or produce changes on business entities. This information is usually known as classes and entity attributes in the Object Oriented domain and can be obtained using existing data modelling techniques, in our case UML

modelling techniques. To portray the way current business processes behave considering the changes that the informational aspects of the current system produce on the model, the BPISS framework identifies those business entities, namely Record Entities (RE) in the BPISS framework that are used in the BPS model and that are affected by the informational aspects of the current system. To reflect the way the current system affects RE, the BPISS decomposes the RE into Field Entities (FE), which in turn represent the information contained in the RE. Because the IS model is constructed within the BPS model, stochastic aspects of the BP are automatically reflected in the IS model, depicting in this way both BP and IS behaviour.

This chapter used the case study presented in Chapter Three to test the BPISS framework. Experimentation results demonstrated that the BPISS model can help to portray IS behaviour. The model provided information about the number of backorders that the IS produces over a given period of time, thus offering a way to observe how different parameters of the IS may affect process performance. For example, new backordering delivery lead-times that reflect the effects that the insertion of the new IS has on processes were obtained. Another outcome of the BPISS framework is that it rendered evidence that confirms that IS static modelling techniques cannot always predict the way the IS behaves in practice. For example, based on the IS description provided by static models, it was thought that the IS would significantly reduce the number of backorders. The results of the to-be BPISS simulation model proved that this was not the case.

Chapter Seven analyses the outcomes of the BPISS framework and compares them against the aims and objectives set for this research. It reflects on both the ASSESS-IT and BPISS framework and assesses how the research described in this dissertation contributes to BP and IS domains, underlining the limitations of the BPISS approach and possible ways to overcome them.

7. Summary and Conclusions

7.1 Introduction

Business Process (BP) and Information Technology (IT) are two domains that are closely related in practice. Based on this fact, the motivation of this research emerges from the assumption that the way this relationship is understood can be improved by the use of modelling mechanisms that provide measurements of the way BP and IT behave. This chapter provides a complete picture of the road taken in this dissertation to achieve this aim. Section 7.2.1 presents a summary of Chapter One describing the background material and the objectives pursued in this dissertation. Section 7.2.2 is a summary of the analysis of BP and IT design approaches and modelling techniques performed in Chapter Two. Chapter Three proposed a simulation framework, namely ASSESS-IT, that aimed to model BP, IS and CN behaviour in an attempt to portray BP and IT interactions. Subsequently, Chapter Four analyses the results obtained from the models developed from such framework. These chapters are summarised in section 7.2.3. Chapter Five uses the knowledge obtained from the ASSESS-IT framework and proposes an alternative framework, namely BPISS, to depict the behaviour of BP and IS. Chapter Six describes the way the BPISS was implemented in the case study presented in Chapter Three. Chapter Five and Six are summarised in section 7.2.4. Section 7.3 reflects on the results obtained from this dissertation and describes the way it contributes to BP and IT domains. Finally, section 7.4 gives details of the limitations found in this dissertation and points to possible research directions to overcome them.

7.2 Summary

Health Warning

In this section, the contents of chapters two to six are summarised with sufficient information to make the findings of the following section clear on those having to go but to chapters two to six.

7.2.1 Background and Objectives

BP and IT practitioners acknowledge that the relationship that BP and IT has in practice is very close so the design of new BP or IT involve analysis in both areas. For example, BP approaches recognise that IT is a major enabler of business processes and thus, the advantages provided by IT and the limitations imposed should be considered when designing BP. Similarly, IS approaches advocate that the design of IS should start with a thorough analysis of the way the organisation operates.

Chapter One assumes that the relationship between BP and IT can be seen as a three layered structure: BP, IS and CN. Business processes rely on information systems to perform many of the activities involved in the processes. Subsequently, the IS layer relies upon a CN infrastructure to share, amongst the most important factors, the information stored and generated by the IS. This research started with the assumption that changes to any of these domains may have unexpected impact on the others and that the success of the implementation of new BP or IT depends on how well this relationship is understood. This suggests that the design of BP and IT should be based, at least partially, on the advantages provided by, and limitations that each of these domains impose upon each other. To this end, Chapter One provided some evidence that positions discrete event simulation technique as the best candidate to model the impact that the insertion of new IT may have on BP. Considering these assumptions, Chapter One proposes a set of objectives to be accomplished in this dissertation, a shorter version of which are to:

1. Provide evidence that current BP and IS design approaches, together with the modelling techniques that support these domains, do not provide a clear guidance of how to assess the impact that changes to IT may have on the business processes and vice versa.
2. Identify the parameters that govern the relationship between Business Processes, Information Systems, and Computer Networks.
3. Propose a simulation framework to portray the interactions amongst BP, IS and CN.
4. Test the aforementioned framework.

5. Refinement of the framework.
6. Appraisal of the results.

To accomplish these objectives Chapter One proposed the use of a single case study approach for theory discovery, building and testing and provided evidence that supports the use of this particular research method.

7.2.2 Modelling BP and IT Performance: A BP and IS Design Problem.

The literature review presented in Chapter Two provided evidence that there is an opportunity to improve the way BP and IT domains address the relationship between them. It was found that the way BP approaches assess the impact that IT may have on BP leaves some room for improvement. A similar opportunity was found in IS approaches. IS design focuses on technical aspects of the IS, and that there is the possibility to provide more guidance to address the organisational factors that may affect IS design. To exemplify these assumptions two BP and two IS design approaches were reviewed in Chapter Two. The approaches were selected considering that they claim to address both organisational and IT aspects in the design of BP and IS. BP approaches reviewed were Davenport (1993) and Kettinger et al. (1997). IS approaches reviewed were Merise and Information Engineering (IE).

The BP approaches reviewed suggest that a business process redesign study should begin by capturing business objectives and then set the performance goals needed to achieve these objectives. The new processes have to be designed so they meet the performance goals previously set. To do so, the BP domain relies on dynamic modelling techniques, such as Business Process Simulation (BPS), to obtain BP performance measurements. These measurements are used to analyse current BP performance and to validate that the proposed solutions satisfy the organisational goals. These measurements, though, are currently based on organisational factors and do not reflect the effect that the insertion of new IT may have on BP performance. This research found that a modelling mechanism that portrays both BP and IT behaviour could help to assess the advantages provided by the insertion of new IT and the side-effects that this may produce in the BP.

Chapter Two also reviewed IT approaches in order to investigate the way they address the relationship between IT and BP. The review found that the IS domain, like BP approaches, consider that in order to develop better IS, organisational goals need to be carefully captured and that IS methodologies should verify that these requirements are addressed in IS design. Considering that BP and IT are closely related, it could be inferred that IS design also verifies that the organisational needs, usually represented as Non-Functional Requirements (NFR), are validated before IS implementation. The review found that the techniques used to model non-functional requirements are mainly aimed to capture non-functional requirements and not at verifying that these are met by the information system. This opened the opportunity to investigate other possible modelling mechanisms that provide the means to assess, prior implementation, that the proposed IS satisfies NFR.

This research provided evidence that BP and IT domains advocate addressing organisational and informational issues in IS and BP design. The review of design approaches and modelling techniques in these domains showed that despite both domains attempt to accomplish this aim, the way modelling techniques are currently applied leaves some room for improvement. For instance, BP approaches use dynamic modelling techniques to obtain behavioural measurements of the processes under analysis and to compare them against the organisational objectives to verify that the proposed processes satisfy organisational needs. A possible way to improve this technique is to obtain process behaviour measurements that consider the impact produced by the insertion of new IT. This research suggests that the stochastic factors produced by the insertion of IT may have unpredicted effects on process performance. Thus, they should be considered in BP and IT design.

Based on the fact that simulation techniques have been successfully used in the BP domain to provide BP performance measurements, this research aimed to propose a simulation framework to investigate the possibility to use discrete-event simulation techniques to provide performance measurements of the way BP and IT behave. The following section reviews the proposed framework, namely ASSESS-IT, and the outcomes derived from this approach.

7.2.3 Analysing the BP and IT Relationship: The ASSESS-IT Experience

The literature review presented in Chapter Two provided evidence that simulation techniques have proved successful to depict the dynamic behaviour of the system under analysis. Furthermore, the review also provided evidence that simulation techniques have been used in both BP and IT domains, in particular business process simulation and Computer Network Simulation (CNS). In Chapter Three this research investigated the viability of using discrete event simulation techniques in a modelling framework to depict BP and IT interactions. The major advantage of BPS over other process modelling techniques is that it depicts the stochastic behaviour of BP and provides the means to assess, prior implementation, whether the proposed processes address the organisational goals. It has been argued in Chapter Two that a possible way to improve the way simulation has been applied in BP design is to consider the impact that IT may have on BP performance. Considering these assumptions, this research aimed to complement BPS techniques by combining an IT modelling technique that addresses IT stochastic factors with BPS. The review of IT modelling techniques showed that CNS was the best candidate since it provides the means to model the behaviour of CN within a given IS context. This research assumed that results from CNS models could be fed into the BPS model, portraying in this way the impact that IT may have on the BP.

The simulation steps proposed in Banks et al. (2000) were used as the basis to develop the ASSESS-IT framework. The simulation steps proposed by Banks et al. aimed to design one simulation model whereas the framework proposed in Chapter Three aimed to develop two simulation models: BP and CN. Therefore, the ASSESS-IT framework adapted Banks et al.'s steps so the new framework provides guidance to coordinate the design of BPS and CNS models and to share information between them. The changes proposed in the ASSESS-IT framework aimed to achieve the following objectives:

1. To coordinate the design of BP and IT so the corresponding models (BPS and CNS) include both BP and IT views.

2. To specify how and where the results from the CNS model can be used in the BPS model (and vice versa) so changes in one model are reflected in the other.
3. To specify where possible iteration cycles between model results and model experimentation will be needed.

The ASSESS-IT framework was tested using the case study described in Chapter Three. The application of the ASSESS-IT framework provided evidence that some of the assumptions made in relation to the way BP, IS and CN relate needed to be reassessed. For instance, the analysis of the development of the CNS model described in Chapter Four showed that BPS and CNS models work on different levels of abstraction. BPS models work in terms of big units of time, such as minutes, hours, days, or even months, whereas CNS models work in terms of small units of time, such as seconds and milliseconds. When results from both models were combined, it soon became apparent that the way the ASSESS-IT framework reflected that the impact that IT has on BP performance was in terms of time. The experiments showed, however, that those processes that rely on IT to deliver their outputs are not likely to depend on time. It was demonstrated that, despite the fact the insertion of IT produced a substantial reduction of time in some of the activities, the overall process performance showed very little improvement. This fact suggested that the CN infrastructure influenced, in a limited way, the relationship between BP, IS and CN, and thus this relationship could be reduced to the relationship between BP and IS.

Once it was observed that the relationship between BP and IT could be depicted by the relationship between BP and IS, this research looked at the way this relationship works and the parameters likely to govern this relationship. The literature review found that non-functional requirements and specifically performance requirements are used to match IS design against the organisational goals, ensuring in this way that the IS meet user requirements. The literature review, however, also showed that the way IS non-functional requirements are identified leaves room for improvement. For example, the experiments described in Chapter Four showed that BPS models can be used as an alternative technique to identify IS performance requirements. It was found that performance measurements obtained from BPS models could be related to some of the NFR specified for the IS. Furthermore, the experiments

showed that in order to predict the impact that the proposed IS may have on the BP, it is necessary to depict IS performance. It was found that the informational aspects of the IS could be used in a BPS simulation tool to depict the stochastic aspects of IS, depicting in this way IS behaviour and the impact that this may have on the BP.

The following section describes the way the results obtained by the application of the ASSESS-IT framework were used to propose a new framework to assess the impact that IT may have on BP performance focusing upon the relationship between BP and IS alone.

7.2.4 Modelling BP and IS Behaviour: The BPISS Framework

The results derived from the ASSESS-IT framework suggested that the relationship between BP and IT can be described as the relationship between business processes and the information system that support those processes. The analysis of the BPS models developed in Chapter Four also provided evidence that in order to depict the interactions between BP and IS it is necessary to portray IS performance requirements. Chapter Five reflected upon these findings and proposed a new simulation framework, namely BPISS, that aimed to construct BPS models that depict business process and information systems performance. The BPISS framework, then aimed to accomplish the following objectives:

1. Identify IS non-functional requirements.
2. Verify that the proposed IS satisfies the non-functional requirements specified previously.
3. Identify input BP and IS variables that affect IS and/or BP performance.
4. Identify conflicts and tradeoffs between IS non-functional requirements.

The results obtained from the BPISS framework models verified that these objectives were accomplished. For instance, the BPS model used in Tier Three of the BPISS framework provided evidence that BPS models can be used to identify performance requirements that may not be identified by current requirements capturing techniques. The analysis of the way processes behave helped to identify process bottlenecks. It was found that these bottlenecks

provided information about the way IT could help to alleviate these problems. This information could be used to derive the proposed IS requirements. For example, the analysis of the business process model of the case study presented in Chapter Three found that reducing the number of backorders could help to reduce the overall ordering delivery time. Despite the fact that this performance requirement seems to be obvious, it was not identified when capturing performance requirements and was derived from the analysis of the behaviour of the business processes.

The to-be model derived from the BPISS framework helped to verify that the proposed IS satisfies the performance requirements stated before. The results obtained from the to-be BPISS model proved that the insertion of the IS reduced ordering and backordering lead-time, which is one of the performance requirements set in Tier Three. The way the IS was designed, though, did not meet the second requirement, which is the reduction of the number of backorders produced in the system. The results showed that instead of decreasing the number of backorders, the insertion of the new IS increases the number of backorders. The to-be BPISS model provided evidence that a simulation model that depicts process and information system behaviour can help to predict the impact that the IS may have on the processes. Furthermore, the experiments performed in Tier Fourteen helped to identify the parameters that can help to improve IS and hence, BP performance. The model resulting from the BPISS framework reflects the impact produced on BP performance due to changes on IS parameters. For example, it was found that if product stock levels were changed the number of backorders were reduced.

7.3 Findings from the Research

This research examined the way Business Processes (BP) and Information Technology (IT) relate and developed modelling mechanisms to depict this relationship. Based on the fact that BP rely on Information Systems (IS) to perform many of the activities involved and that the latter rely on a Computer Network (CN) infrastructure to manipulate the information held by the IS, this dissertation assumed that the relationship between BP and IT can be alternatively described as the relationship between BP, IS, and CN. To

investigate the way these three domains interact, two modelling frameworks were developed in this dissertation, namely ASSESS-IT and BPISS frameworks.

The findings of this research can be summarised analysing the outcomes derived from the experimentation of both frameworks. The results from the ASSESS-IT framework are analysed in section 7.3.1. The results from the BPISS framework are analysed in section 7.3.2.

7.3.1 The ASSESS-IT Framework Experience

Two major lessons can be learnt from the experimentation with the ASSESS-IT framework. The first lesson is that the relationship between BP, IS and CN can be seen as the relationship between BP and IS if the latter does not depend on a determined response time. One of the major reasons this might happen is due to the temporal mismatch between BP and CN performance measurements. BP performance is usually measured in terms of minutes, hours, days, or weeks, whereas CN performance is generally measured in terms of milliseconds and seconds. Therefore, changes to the CN infrastructure that affect IS performance in, say 80 seconds, did not show a considerable impact on those processes and activities that are measured in terms of hours or days. It could be argued that time could affect BP performance when the IS automates some of the activities involved, thus significantly reducing their processing time. This, however, depends on the way business processes are structured and the relationship between input and output parameters of the business processes. Most business processes are intrinsically related, therefore, the duration of some of the activities depends on the duration of others. Consequently, the time gained due to the automation of some process or activities might be substantially reduced in the next process or activity if the duration of the latter is longer than the automated ones.

The second lesson learnt from ASSESS-IT is that there are other performance measurements than time that may be used to portray the benefits that the use of an IS may bring to the business processes. For example, in the case study it was reported that one of the ways that IS may improve BP performance is by reducing the number of backorders. If performance measurements of the way the IS handles backorders were available, these could be used to assess the impact that IS may have on BP performance. Therefore if we could obtain

performance measurements of the functionality of the IS as it evolves over time, these could be used to assess the impact that the IS may have on BP performance.

Summarising, the ASSESS-IT framework provided evidence that the relationship between BP and IT could be analysed from two different views. The first view is when the IS that supports BP depends on a determined response time. In this case the ASSESS-IT framework could be used to analyse the way time may improve or constrain BP performance. The models developed in the ASSESS-IT framework, however, showed that the IS that supports BP does not always depend on determined response time. The results from ASSESS-IT models suggested that when time is not an IS constraint, the relationship between BP and IT could be analysed focusing on the relationship between BP and IS alone. Moreover, the ASSESS-IT provided evidence that suggests that in order to analyse the relationship between BP and IS it could be useful to obtain performance measurements of the way the IS delivers its functionality.

Based on these results an alternative modelling framework, namely BPISS, was developed. The BPISS framework aimed to develop simulation models that depict the way the way IS may affect process performance. The following section describes the rationale behind BPISS and results derived from the experimentation with this framework.

7.3.2 The BPISS Framework Experience

The BPISS framework provides guidelines to develop BPS models that provide performance measurements considering the functionality of the IS used to support BP. The BPISS models use details of the BP components that may affect the inputs and outputs of the IS. The model performs the operations specified by the IS functionality and returns those values to the BP components. In doing so, the model provides performance measurements of the way the IS is expected to deliver its functionality, such as volumes of data and other performance criteria. These figures can alternatively be described as NFR performance measurements.

The originality of the BPISS framework can be seen when comparing the outcomes derived from a traditional BPS exercise to those derived from the BPISS framework. Traditional BPS models provide performance measurements

of the BP based only on organisational factors whereas the BPISS models provide performance measurements of the BP considering the advantages and limitations provided by the insertion of a given IS design. In this way the modeller can obtain performance measurements of both BP and IS and investigate the impact that the insertion of a given IS design may have on BP performance and vice versa. For example, the BPISS models developed from the case study provided measurements that represented the number of backorders produced by the IS considering a given IS design and the organisational factors that may influence these parameters. These figures were automatically used in the BP model, thus reflecting the effect that the use of IS may have on the overall BP performance.

The experimentation with the BPISS models demonstrated that a model that provides IS performance measurements can provide other relevant information that can be used to identify better BP and IS design solutions. It was found that the IS performance measurements obtained from the BPISS model could be useful to:

- Verify that the IS satisfies non-functional requirements. The BPISS models can be used to obtain specific performance measurements of the IS, which in turn can be matched against the IS NFR specified before, thus assessing, whether the IS meets those requirements or not. For example, the BPISS models derived from the case study provided performance measurements of the number of backorders produced by the IS considering the stochastic factors defined in the BP model. These figures were matched against the NFR requirements specified before.
- Identify the variables that affect IS and/or BP performance. Once a given non-functional requirement is identified, simulation can be used to isolate the process (together with the IS used to support this process) needed to satisfy this requirement. Experimentation can be used to investigate the variables (e.g. resources, entities, etc.) that may affect IS and/or BP performance. For example, it was identified that the product stock levels defined in the IS affect the number of backorders produced by the information system. The modeller was able to "play" with these parameters and identify the BP and IS solution that better suits the organisational goals.

- Identify conflicts and tradeoffs between non-functional requirements. Because the BPISS models reflect the impact that a given IS parameter may have on the whole system, experimentation with different IS parameters can be used to identify the effects that changes in one user requirement may have on the others. For example, in the case study it was identified that the product stock levels defined in the BPISS model will affect the number of travels made by the lorry that replenishes the products.

Due to the fact that traditional BPS models depict performance measurements of the BP based only on organisational issues, the performance measurements described above could not have been obtained with traditional BPS models. Thus, the experiments derived from the BPISS framework demonstrated that the BPISS simulation models provide other relevant information that can be used to identify better BP and IS solutions.

7.4 Further Research

During the development of the ASSESS-IT and BPISS simulation frameworks, this research found that current technology as well as certain aspects of these frameworks exhibited some areas that need further refinement. Because of the focus of this research, it was considered that these areas were beyond the scope of this dissertation and thus were not addressed in this research. This section describes the areas that are considered to need further refinement and points at possible future research directions that can be derived from this dissertation.

One of the problems encountered during the application of the BPISS framework is related to the complexity of the modelling approach. Discrete-event simulation practitioners advocate the idea that simulation models should be in principle "moderately detailed" and that the model should not contain more detail than necessary to address the problem in question. The models proposed in the BPISS framework are not "moderately detailed" since they have to include a combination of BP and IS parameters. Despite the fact that the case study used to test the BPISS framework was relatively simple, the information needed to create the BPISS model amounted to far more than the one used for a simple BPS exercise. The findings of this research discussed in the previous section provided evidence that the models derived from the BPISS framework can

render useful information to be considered in BP and IS design. Considering these two facts, there is the need to investigate the limitations of the BPISS framework when developing broader and more complex IS and BP. The results from such research can provide information that indicates whether the BPISS framework can be used in complex IS and BP systems or if it should be used only on relatively small BP and IS studies.

Another problem found was related to data collection techniques. The BPISS framework requires the collection of information related to both the business processes and the information system under analysis. BPS approaches provide a number of data capturing techniques to develop BPS models. Similarly, the BPISS framework advocates the use of current IS modelling techniques to capture the information needed from the proposed IS. There is, though, other information that needs to be collected and that cannot be obtained from current BP or IS data capturing techniques. This information is related to the stochastic factors of the IS. There is the need to collect stochastic information related to the informational aspects of the process entities under analysis. For example, the case study needed information related to the order and backordering contents, such as the number of different products requested in each order and the quantity of products requested. These measurements are not collected by current IS or BP data capturing techniques and are essential to depict the stochastic aspects of the IS. It is necessary to investigate what the most suitable techniques to capture this data are and to discover the limitations that this may imply.

In relation to the BPS modelling tool used in this dissertation, it was found that some areas needed further analysis. For instance, among the most common techniques used to verify that a simulation model is "correct" are *debugging* and *tracing*. For debugging purposes, it is recommended to write the simulation code in modules or programs so they can be verified individually, simplifying in this way their analysis. The simulation tool used in this research does not permit the division of the code into modules. This created difficulties when debugging the model. Furthermore, as the complexity of the system increases, the difficulty to debug the model increases as well. These problems are usually overcome using tracing facilities provided in most of the BPS tools. These facilities, though, are created to analyse business process model components. Despite the fact that the simulation tool used in the case study provided programming facilities, these

were very limited and complicated the programming of the IS functionality. This limitation is also related to the complexity of the system under analysis. The experience gained from the BPISS framework suggests that the insertion of more complex IS may create programming problems that might not be able to be overcome with the programming facilities provided by current BPS tools. Therefore, it is desirable to experiment with other simulation tools or languages in order to identify the most suitable tool to be used in the BPISS framework or to investigate the possibility of adapting software components that provide such facilities. Furthermore, during the design of the BPISS model it was found that access to a database could simplify many of the limitations found. For example, the informational aspects of the IS were represented as entity attributes in the BPS model. These attributes had to be specified beforehand, though, and cannot be modelled in a dynamic way. The use of a database system that allows the modeller to create links between entities of the BPS model to their corresponding informational aspects would significantly facilitate the development of programming code that portrays the functionality of the IS within the BPS model.

Finally, the research performed in this dissertation provided evidence that BP and IS modelling tools share common information. For instance, it was found that one or many activity diagrams provide information related to the way processes operate. For example, the activity diagrams used in Chapter Six describe, in very similar form, the way processes are described in the BPS model. This suggests that activity diagrams can help to derive business process models and vice versa. Similarly, to develop BP simulation models it is necessary to identify some of the business rules that dictate BP behaviour. This information also can be obtained from collaboration diagrams. Therefore, further research in this domain can be used to provide guidelines that indicate how to share information between BP and IS modelling techniques, providing in this way alternative ways to develop BP and IS models. The development of such guidelines could help to share useful information between BP and IS modelling techniques, reducing in this way design time and assuring the alignment of the design in these areas.

7.5 Critical Re-evaluation

Previous sections presented a reflection on what can be learned from the research activity described from chapters two to six. This section aims to describe some of the lessons concerned with the experience gained during the research process itself. Two major lessons are summarised in the following paragraphs.

The Hypothesis Building Process. This research started from some theoretical and practical evidence, which helped to propose the central hypothesis of this research. This hypothesis at first sight seemed worthy and challenging. After the experimentation with the case study, I realised that the hypothesis was not valid and that it needed further refinement. At this point, it became clear that the facts that invalidated this theory could have been previously identified if the hypothesis had been analysed in more detail at the beginning. A lesson that can be derived from this experience is that after proposing a hypothesis, it is advisable to analyse it with a critical view, trying to find any possible limitations that could have been previously overlooked. This can save valuable time and help to focus the research in the desired direction.

Choosing a Case Study. It was thought that a case study strategy was sufficiently viable to prove or disprove the hypothesis stated in this dissertation. One of the major problems found during the development of this research is that the case study used to test the hypothesis did not allow the investigation of the problem to the desired depth. This required the spending of more time trying to overcome the limitations of the case study. Moreover, since the case study did not fully satisfy the research requirements, the results derived from the experimentation were based on limited information, a situation that possibly jeopardises the validity of the results. Therefore, it is advisable to find sufficient time during the research activity to identify a case study that meets the research purposes.

References

- Armistead, C., Harrison, A. and Rowlands, P. (1995) Business Process Re-engineering: Lessons from Operations Management. *International Journal of Operations & Production Management*, 15 (12), pp.46-58.
- Avison, D.E. and Fitzgerald, G. (1995) *Information Systems Development: Methodologies, Techniques and Tools*. 2nd ed. London: McGraw-Hill.
- Banks, J., Carson, J.S., Nelson, B.L. and Nicol, D.M. (2000) *Discrete-event System Simulation*. 3rd ed. Upper Saddle River, NJ.: Prentice-Hall.
- Basta, R.A., Kraemer, B.P., Bond, W.P. and Billhartz, T.J. (1992) Distributed Communication Network Systems Performance Modeling. *Council on Systems Engineering*, pp.365-372.
- Benbasat, I., Goldstein, D.K. and Mead, M. (1988) Letter to the Editor. *MIS Quarterly*, 12 pp.522.
- Bennett, S., McRobb, S. and Farmer, R. (1999) *Object-oriented Systems Analysis and Design Using UML*. London: McGraw-Hill.
- Bhattacharjee, A. and Hirschheim, R. (1997) IT and Organizational Change: Lessons from Client/Server Technology Implementation. *Journal of General Management*, 23 (2), pp.31-46.
- Braa, K. and Vidgen, R. (1995) Action Case: Exploring The Middle Kingdom in IS Research Methods. Bodker (Ed). *Proceedings of Third Decennial Conference Computers in Context: Joining Forces in Design*, Aarhus, Denmark, August 14-18. pp.50-60.
- Britton, C. and Doake, J. (1996) *Software System Development: A Gentle Introduction*. London: McGraw-Hill International.
- Checkland, P. (1981) *Systems Thinking, Systems Practice*. Chichester: Wiley.
- Childe, S.J., Bennett, J. and Maul, J. (1994) Frameworks for Understanding Business Process Re-engineering. *International Journal of Operations & Production Management*, 14 (12), pp.22-34.
- Chung, L. and Nixon, B.A. (1995) Dealing with Non-functional Requirements: Three Experimental Studies of a Process-oriented Approach. *Proceedings of the 17th*

- International Conference on Software Engineering*, Seattle, WA, April 24-28. pp.25-37.
- Curtis, B., Over, J. and Kellner, J. (1992) Process Modelling. *Communications of the ACM*, 35 (9), pp.10-15.
- Cysneiros, L.M. and do Prado Leite, J.C.S. (1999) Integrating Non-Functional Requirements into Data Modelling. *Proceedings of the IEEE International Symposium on Requirements Engineering*, Limerick, Ireland, June 7–11. IEEE, pp.162-171.
- Davenport, T.H. (1993) *Process Innovation: Reengineering Work through Information Technology*. Boston, MA: Harvard Business School Press.
- Davenport, T.H. and Short, J.E. (1990) The New Industrial Engineering: Information Technology and Business Process Redesign. *Sloan Management Review*, 31 (4), pp.11-27.
- Davenport, T.H. and Stoddard, D.B. (1994) Reengineering: Business Change of Mythic Proportions? *MIS Quarterly*, 18 (2), pp.121-127.
- Dorant, J. and Gilbert, N. (1994) *Simulating Societies: The Computer Simulation of Social Phenomena*. London: UCL Press.
- Finkelstein, C. (1992) *Information Engineering : Strategic Systems Development*. Sydney: Addison-Wesley.
- Galliers, R.D. (1991) Choosing Appropriate Information Systems Research Approaches: A Revised Taxonomy. *Information Systems Research: Contemporary Approaches and Emergent Traditions*, pp.327-345.
- Garvin, D.A. (1988) *Managing Quality*. New York: Free Press.
- Giaglis, G.M. (1999) *Dynamic Process Modelling for Business Engineering and Information Systems*. Unpublished PhD Thesis, Brunel University, London.
- Giaglis, G.M. (2001) A Taxonomy of Business Process Modelling and Information Systems Modelling Techniques. *International Journal of Flexible Manufacturing Systems*, 13 (2), pp.209-228.
- Gladwin, B. and Tumay, K. (1994) Modelling Business Processes with Simulation Tools. Tew, J.D., Manivannan, S., Sadowski, D.A. and Seila, A.F. (Eds). *Proceedings of*

References

- the 1994 Winter Simulation Conference*, Lake Buena Vista, FL, December 11-14. pp.114-121.
- Gordon, J. (1978) *System Simulation*. 2nd ed. Englewood Cliffs, NJ: Prentice-Hall.
- Grover, V., Kettinger, W.J. and Teng, J.T.C. (2000) Business Process Change in the 21st Century. *Business and Economic Review*, 46 (2), pp.14-18.
- Hammer, M. and Champy, J. (1993) *Reengineering the Corporation: A Manifesto for Business Revolution*. New York, NY: Harper Collins Publishers.
- Hares, J.S. (1992) *Information Engineering for the Advanced Practitioner*. Chichester: Wiley.
- Hlupic, V. and Robinson, S. (1998) Business Process Modelling and Analysis Using Discrete-Event Simulation. Medeiros, D.J., Watson, E.F., Carson, J.S. and Manivannan, M.S. (Eds). *Proceedings of the 1998 Winter Simulation Conference*, Washington, DC, December 13-16. The Society for Computer Simulation International, pp.1363-1369.
- Imache, R. (1998) SSADM and MERISE: Towards the European Method. *Modelling, Measurement & Control*, 17 (2), pp.41-49.
- Irani, Z., Ezingear, J.N., Grieve, R.J. and Race, P. (1999) A Case Study Strategy as Part of an Information Systems Research Methodology: A Critique. *International Journal of Computer Applications in Technology*, 12 (2/3/4/5), pp.190-198.
- Jacobson, I., Christerson, M., Jonsson, P. and Ovegaard, G. (1992) *Object-Oriented Software Engineering : A Use Case Driven Approach*. Wokingham: Addison-Wesley.
- Juran, J. (1964) *Managerial Breakthrough: A New Concept of the Manager's Job*. New York, NY: McGraw-Hill.
- Kettinger, W.J., Teng, J.T.C. and Guha, S. (1997) Business Process Change: A Study of Methodologies, Techniques, and Tools. *MIS Quarterly*, 21 (1), pp.55-80.
- Law, A.M. and Kelton, D.W. (2000) *Simulation Modelling and Analysis*. 3rd ed. New York, NY: McGraw-Hill.
- Law, A.M. and McComas, M.G. (1994a) Simulation of Communication Networks. Tew, J.D., Manivannan, M.S., Sadowski, D.A. and Seila, A.F. (Eds). *Proceedings of the*

- 1994 *Winter Simulation Conference*, Orlando, Florida, December 11-14. The Society for Computer Simulation International, pp.166-170.
- Law, A.M. and McComas, M.G. (1994b) Simulation of Communication Networks: The State of the Art. *IEEE Communications*, 32 pp.44-50.
- Law, A.M. and McComas, M.G. (1996) Simulation of Communication Networks. Charnes, J.M., Morrice, D.J., Brunner, D.T. and Swain, J.J. (Eds). *Proceedings of the 1996 Winter Simulation Conference*, Coronado, California, December 8-11. The Society for Computer Simulation International, pp.73-77.
- Lee, A.S. (1989) A Scientific Methodology for MIS Case Studies. *MIS Quarterly*, 13 (1), pp.32-50.
- Liles, D.H. and Presley, A.R. (1996) Enterprise Modelling Within an Enterprise Engineering Framework. Charnes, J.M., Morrice, D.J., Brunner, D.T. and Swain, J.J. (Eds). *Proceedings of the 1996 Winter Simulation Conference*, Coronado, California, December 8-11. The Society for Computer Simulation International, pp.993-999.
- MacArthur, P.J., Crosslin, R.L. and Warren, J.R. (1994) A Strategy for Evaluating Alternative Information System Designs for Business Process Reengineering. *International Journal of Information Management*, 14 (4), pp.237-251.
- Martin, J. (1989) *Information Engineering*. Vol. 1. Englewood Cliffs, NJ: Prentice-Hall.
- Mauil, R.S., Weaver, A.M., Childe, S.J., Smart, P.A. and Bennett, J. (1995) Current Issues in Business Process Re-engineering. *International Journal of Operations & Production Management*, 15 (11), pp.37-52.
- Mylopoulos, J., Chung, L. and Nixon, B.A. (1992) Representing and Using Non-Functional Requirements: A Process Oriented Approach. *IEEE Transactions on Software Engineering; Special Issue on Knowledge Representation and Reasoning in Software Development*, 18 (6), pp.483-497.
- Naylor, T.H., Balintfy, J.L., Burdick, D.S. and Chu, K. (1966) *Computer Simulation Techniques*. New York: Wiley.
- Nixon, B.A. (1998) Managing Performance Requirements for Information Systems. *Proceedings of the First International Workshop on Software and Performance*, Santa Fe, New Mexico, October 12-16. ACM Press, pp.191-144.

References

- Nixon, B.A. (2000) Managing Performance Requirements for Information Systems. *IEEE Transactions on Software Engineering*, 26 (12), pp.1122-1146.
- Nuseibeh, B. and Easterbrook, S. (2000) Requirements Engineering. *Proceedings of the 22th International Conference on Software Engineering*, Limerick, Ireland, June 4-11. ACM Press, pp.35-46.
- O'Brien, J.A. (1999) *Management Information Systems*. 4th ed. London: McGraw Hill.
- Ould, A.M. (1995) *Business Processes : Modelling and Analysis for Re-engineering and Improvement*. Chichester: Wiley.
- Painter, M.K., Fernades, R., Padmanaban, N. and Mayer, R.J. (1996) A Methodology for Integrating Business Process and Information Infrastructure Models. Charnes, J.M., Morrice, D.J., Brunner, D.T. and Swain, J.J. (Eds). *Proceedings of the 1996 Winter Simulation Conference*, Coronado, California, December 8-11. The Society for Computer Simulation International, pp.1305-1312.
- Paul, R.J. and Balmer, D.W. (1993) *Simulation Modelling*. Lund, Sweden: Chartwell-Bratt Publishing.
- Paul, R.J., O'Keefe, R., Giaglis, G.M., Eatock, J. and Serrano, A. (2000) *Integrated Business Process and Computer Network Simulation: A Case Study*. ASSESS-IT Deliverable 5, Brunel University, London.
- Powell, T.C. and Dent-Micallef, A. (1997) Information Technology as Competitive Advantage: The Role of Human, Business, and Technology Resources. *Strategic Management Journal*, 18 (5), pp.375-405.
- Rhodes, D. (1998) Integration Challenge for Medium and Small Companies. BPICS (Ed). *Proceedings of the 23rd Annual Conference of British Production and Inventory Control Society*, Birmingham, November 24. pp.153-166.
- Rochfeld, A. and Tardieu, H. (1983) MERISE: An information System Design and Development Methodology. *Information and Management*, 6 (3), pp.143-459.
- Rolland, C. and Prakash, N. (2000) From Conceptual Modelling to Requirements Engineering. *Annals of Software Engineering*, 10 (1/4), pp.151-176.
- Sauer, C.H. and MacNair, E.A. (1983) *Simulation of Computer Communication Systems*. Englewood Cliffs, London: Prentice-Hall.

References

- Schein, E. (1969) *Process Consultation: Its Role in Organisation Development*. Reading, MA: Addison-Wesley.
- Shannon, R.E. (1975) *Systems Simulation: The Art and the Science*. Englewood Cliffs, NJ: Prentice Hall.
- Sommerville, I. (1997) *Software Engineering*. 5th ed. Wokingham: Addison-Wesley.
- Stevens, P. and Pooley, R.J. (2000) *Using UML : Software Engineering with Objects and Components*. Harlow: Addison-Wesley.
- Tumay, K. (1996) Business Process Simulation. Charnes, J.M., Morrice, D.J., Brunner, D.T. and Swain, J.J. (Eds). *Proceedings of the 1996 Winter Simulation Conference*, Coronado, CA, December 8-11. The Society for Computer Simulation International, pp.93-98.
- Turban, E., McLean, E. and Wetherbe, J. (1996) *Information Technology for Management: Improving Quality and Productivity*. John Wiley & Sons.
- Vessey, I. and Glass, R. (1998) Strong Vs. Weak : Approaches to Systems Development. *Communications of the ACM*, 41 (4), pp.99-102.
- Warren, J.R., Crosslin, R.L. and MacArthur, P.J. (1995) Simulation Modeling for BPR: Steps to Effective Decision Support. *Information Systems Management*, 12 (4), pp.32-42.
- Weick, K.E. (1984) Theoretical Assumptions and Research Methodology Selection. in *The Information Systems Research Challenge*. McFarlan, F.W. (Ed.) Harvard Business School, Boston, Mass., pp. 111-129.
- Williams, T. (1999) Towards Realism in Network Simulation. *OMEGA, The International Journal of Management Science*, 27 pp.305-314.
- Yin, R.K. (1994) *Case Study Research : Design and Methods*. 2nd ed. Vol. 5. Thousand Oaks, California: Sage.
- Yourdon, E. (2001) *Modern Structured Analysis*. 2nd ed. Englewood Cliffs, N.J.: Prentice-Hall.
- Zave, P. and Jackson, M. (1997) Classification of Research Efforts in Requirements Engineering. *ACM Computing Surveys*, 29 (4), pp.315-321.