



# Wavelet based Fault Detection Method for Ungrounded Power System with Balanced and Unbalanced load

V.R.Sheelavant<sup>\*1</sup>, Vijaya C<sup>2</sup>, S.C. Shiralashetti<sup>3</sup>

<sup>1</sup>Dept. of Electrical Engineering, SDM College of Engineering and Technology, Dharwad-580002, INDIA

<sup>2</sup>Dept. of Electronics and communication Engineering, SDM College of Engineering and Technology, Dharwad-580002, INDIA

<sup>3</sup>Dept. Of Mathematics, Karnatak University's Karnatak Arts College, Dharwad -580001, INDIA

## Abstract

Modern spectral and harmonic analysis is based on Fourier transforms. However, these techniques are less efficient in tracking the signal dynamics for transient disturbances. Consequently, the wavelet transform has been introduced as an adaptable technique for non-stationary signal analysis. Although the application of wavelets in the area of power system engineering is still relatively new, it is evolving very rapidly. In this paper wavelet based method for detection of faults in an ungrounded integrated power system (IPS) of Navy ships is proposed. However the "Virtual ground" exists between the modules of IPS and ship hull, because of insulation capacitance of the cable and the EMI filters between the modules of the IPS. The fault current is very low for a single line to ground fault in this ungrounded system allowing continuous operation but also making fault detection difficult. The proposed method uses wavelets for detection of ground fault in ungrounded power system. The ground fault conditions are simulated using MATLAB-SIMULINK and fault detection implemented with Daubechies wavelets. It is shown that transient ground faults can be detected by wavelet analysis of the line to line voltages when ship load is balanced and unbalanced. Verification of the proposed method has been done by simulating fault between a line and ship hull and analyzing the results.

**Keywords:** Wavelet transform, fault detection, ungrounded power system, balanced load, unbalanced load, Daubachies wavelets.

## 1. Introduction

The integrated power system (IPS) of Navy ship board is ungrounded to allow operation during faults, yet cable capacitance and filters provide stray paths to the ship's hull, resulting in very low current for a single line to ground fault in an ungrounded system. Under such circumstances, line to line and phase voltage amplitudes are unchanged. This ensures a high continuity of service which is the Navy's motivation for installing ungrounded systems in ships. These systems are however subjected to high transient over voltages to ground and consequently are a potential hazard to equipment and operating personnel. These faults also cause insulation stress leading to insulation failure and more severe faults [1-2].

Fault detection in Power system is the issue of increasing concern both to the utilities and their customers. For detecting fault, data is often available in the form of a sampled time function that is represented by a time series of amplitudes. When dealing with such data, the Discrete Fourier Transform (DFT) based approach is most often used. The implementation of the DFT by various algorithms has been constructed as the basis of modern spectral and harmonic analysis. The DFT yields frequency coefficients of a signal, which represents the projection of orthogonal Sine and Cosine basic functions. Such transforms have been successfully applied to stationary signals where the frequencies of the signals do not vary with time. However, for non-stationary signals, any abrupt change may spread all over the frequency axis. Under this situation, the Fourier techniques are less efficient in tracking the signal dynamics, therefore, an analysis adaptable to non-stationary signals is required instead of Fourier based methods. Consequently, the Short Time Fourier Transform (STFT) uses a (time-frequency) window to localize - in time - sharp transitions for non-stationary signals. The STFT uses a fixed time frequency window, which is inadequate for the practical power system faults encountering change in frequencies.

The Wavelet Transform (WT) technique, recently proposed in literature as a new tool for monitoring power quality problems [3-7], has received considerable interests in field of power system signal processing [8-9]. The WT is well suited to wide band signals that may not be periodic and may contain both sinusoidal and non sinusoidal components. This is due to the ability of wavelets to focus on short time intervals for high frequency components and long time intervals for low frequency components.

In this paper the output line voltages at load terminals are used as the medium for fault detection. A line to ground fault is defined as a single connection between a phase and the ship's hull. MATLAB-SIMULINK is used to generate the line to line voltage data for the various faulted conditions. A Wavelet analysis using Daubechies Wavelets is then applied to line voltages. The coefficients of the detailed scales are examined to determine the line on which ground fault has occurred in balanced load or unbalanced load conditions.

This paper is organized as follows. Section-2 presents Wavelet transform and Multi-resolution analysis. Section-3 concerns with the proposed Wavelet based fault detection method for balanced and unbalanced ungrounded power system. Section-4 deals with MATLAB-SIMULINK model used for generation of line to line voltage data for fault conditions in Naval typical integrated power system and implementation of the developed algorithm to demonstrate

the efficiency and effectiveness of the proposed method. Numerical findings are presented in the form of graphs and tables.

## 2. Wavelet Transform and Multi- Resolution Analysis

The wavelet transform is a recently developed mathematical tool that provides a decomposition of data or signal, into different frequency components, and makes it possible to study each component with a resolution matched to its scale [10]. It is often used in the analysis of transient signals because of its ability to extract both time and frequency information simultaneously, from such signals. The comparison of the WT with the Fourier transforms (FT) and why it is preferred to the FT has been documented in [11].

Multi-Resolution Analysis (MRA) is an alternative approach used to analyze signals to overcome the time and frequency resolution problems, since these problems persist regardless of the transform employed. MRA analyses the signal at different frequencies with different resolutions. It does not resolve every spectral component of the signal equally. It is designed to produce good time resolution and poor frequency resolution at high frequencies and vice versa. The rationale behind this is that the signals that are encountered in practical applications have high frequency components for short durations and low frequency components for long durations.

In Discrete wavelet transform (DWT), a time scale representation of a digital signal is obtained using digital filtering techniques [12]. DWT uses filters of different cut-off frequencies to analyze the signal at different scales. The signal is passed through a series of high pass filters to analyze the high frequencies, and it is equally passed through a series of low pass filters to examine the low frequencies. Filtering a signal is synonymous with the mathematical operation of convolution of the signal with the impulse response of the filter [13] as presented in equation (1).

$$x[n] * h[n] = \sum_{k=-\infty}^{\infty} x[n] \cdot h[n - k] \quad (1)$$

Where  $x[n]$  is a discrete time function,  $n$  is number of signal samples and  $h[n]$  is the low pass filter impulse response. The most important part of many signals is the low frequency content; it gives the signal its identity. The high frequency content, on the other hand, only impacts flavor. This is what brings into wavelet analysis, *approximations* and *details*.

*Approximations* are the high-scale, low frequency components of the signal, while *details* are the low-scale, high frequency components. *Approximations* (also known as the scaling coefficients) are computed by taking the inner products of the function  $x(t)$ , the signal, with the scaling basis  $\phi_{j,k}(t)$ , achieved with equation (2). *Details* (also known as the wavelet coefficients) are computed mathematically by taking the inner products of the function  $x(t)$  with the wavelet basis  $\psi_{j,k}(t)$ , as in equation (3).

$$a_{j,k} = \langle x(t), \phi_{j,k}(t) \rangle = \int_{-\infty}^{\infty} x(t) \cdot \phi_{j,k}(t) \quad (2)$$

$$c_{j,k} = \langle x(t), \psi_{j,k}(t) \rangle = \int_{-\infty}^{\infty} x(t) \cdot \psi_{j,k}(t) \quad (3)$$

As mentioned earlier, DWT analyzes the signals at different frequency bands with different resolutions by decomposing the signal into coarse approximation and detail information. DWT uses *scaling functions* and *wavelet functions* in achieving this. These two sets of functions are associated with low pass and high pass filters, respectively. The original signal  $x[n]$  is first passed through a half band high pass filter  $g[n]$  and a low pass filter  $h[n]$ . As said previously, after filtering, half of the samples would be eliminated. The signal can therefore be sub sampled by two. This constitutes one level of decomposition and can be expressed, mathematically as follows:

$$a_i[n] = \sum_k x[n] \cdot h[2n - k] \quad (4)$$

$$c_i[n] = \sum_k x[n] \cdot g[2n - k] \quad (5)$$

where  $c_i$  is the output from the high-pass filter called *detail coefficient* and  $a_i$  is the output from the low-pass filter called *approximation coefficient*.

Where,  $i=1, 2, \dots, I$  is resolution level found to be  $I = \frac{\log(n)}{\log(2)}$ ,  $n$  is number of samples in signal to be analyzed and  $K$  is the length of the filter vector, after down sampling by two [14]. The signal decomposition process can be done iteratively with successive approximations being decomposed in turn, so that one signal is broken down into many to get required resolution components. Figure.1 [15] illustrates a multiple level decomposition procedure for a signal  $x[n]$ .

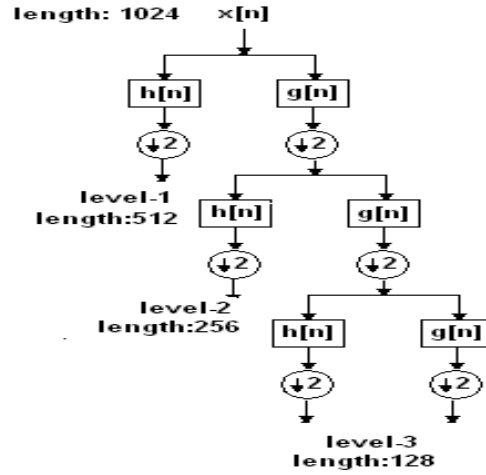

Fig. 1 A three level multiresolution decomposition.

In this paper we have used Daubechies wavelets ( $DB_4$ ) with following four low pass and high-pass filter coefficients.

Low pass filter coefficients:

$$h_0 = \frac{1 + \sqrt{3}}{4\sqrt{2}}, h_1 = \frac{3 + \sqrt{3}}{4\sqrt{2}}, h_2 = \frac{3 - \sqrt{3}}{4\sqrt{2}}, h_3 = \frac{1 - \sqrt{3}}{4\sqrt{2}}$$

High pass filter coefficients:

$$g_0 = h_3, \quad g_1 = -h_2, \quad g_2 = h_1, \quad g_3 = -h_0$$

The  $a_i$  and  $c_i$  are calculated by taking Forward Wavelet Transform of the signal, Forward transform using  $DB_4$ :

$$D = W_4 X$$

For a signal of eight sample length:

$$D = \begin{bmatrix} a_0 \\ c_0 \\ a_1 \\ c_1 \\ a_2 \\ c_2 \\ a_3 \\ c_3 \end{bmatrix}_{8 \times 1} = \begin{bmatrix} h_0 & h_1 & h_2 & h_3 & 0 & 0 & 0 & 0 & 0 & 0 \\ g_0 & g_1 & g_2 & g_3 & 0 & 0 & 0 & 0 & 0 & 0 \\ 0 & 0 & h_0 & h_1 & h_2 & h_3 & 0 & 0 & 0 & 0 \\ 0 & 0 & g_0 & g_1 & g_2 & g_3 & 0 & 0 & 0 & 0 \\ 0 & 0 & 0 & 0 & h_0 & h_1 & h_2 & h_3 & 0 & 0 \\ 0 & 0 & 0 & 0 & g_0 & g_1 & g_2 & g_3 & 0 & 0 \\ 0 & 0 & 0 & 0 & 0 & 0 & h_0 & h_1 & h_2 & h_3 \\ 0 & 0 & 0 & 0 & 0 & 0 & g_0 & g_1 & g_2 & g_3 \end{bmatrix}_{8 \times 10} * \begin{bmatrix} x_0 \\ x_1 \\ x_2 \\ x_3 \\ x_4 \\ x_5 \\ x_6 \\ x_7 \\ x_0 \\ x_1 \end{bmatrix}_{10 \times 1}$$

The use of  $DB_4$  “accurate”, since change in the input data set is reflected in the high pass filter results at each transform step. The cost of using the Daubechies algorithm is higher computation overhead (twice the number of operations, compared to Haar) and a more complicated algorithm (the algorithm must properly handle the edge condition where  $i = 0$ ). The higher accuracy of the Daubechies algorithm is worth and the cost is application dependent [16-20].

## 2.1 Wavelet based fault detection method for ungrounded power system

The proposed wavelet prototype function, the analyzing wavelet or the mother wavelet temporal analysis is performed by shifting a contracted high frequency versions of the mother wavelet, while frequency analysis is performed with dilated, low frequency versions of the same wavelet. Any signal can be represented in terms of a wavelet expansion or series (similar to Fourier series) using coefficients in a linear combination of the wavelet function at different scales. The selection of the mother wavelet depends on the signal under analysis. Different mother wavelets exist with various characteristics.

In the following proposed method  $DB_4$  is considered. The line voltages  $V_{AB}, V_{BC}$  &  $V_{CA}$  at load terminals in figure 4.1(f) are represented as signal  $X$  of order  $n \times 1$ . Applying wavelet transform to  $X$  we get decomposition matrix of order  $n \times 1$ , i.e.

$$\begin{aligned}
1^{\text{st}} \text{ level decomposition} \rightarrow D_1 &= [W_4]_{n \times (n+2)} [X]_{(n+2) \times 1} = \begin{bmatrix} A_1 \\ C_1 \end{bmatrix}_{n \times 1} \\
2^{\text{nd}} \text{ level decomposition} \rightarrow D_2 &= [W_4]_{\frac{n}{2} \times (\frac{n}{2} + 2)} [C_1]_{(\frac{n}{2} + 2) \times 1} = \begin{bmatrix} A_2 \\ C_2 \end{bmatrix}_{\frac{n}{2} \times 1} \\
&\dots \\
I^{\text{th}} \text{ level decomposition} \rightarrow D_I &= [W_4]_{2 \times 4} [C_{(I-1)}]_{4 \times 1} = \begin{bmatrix} A_I \\ C_I \end{bmatrix}_{2 \times 1}
\end{aligned}$$

where,  $i=1, 2 \dots I$ ,  $A_i$  is an approximation coefficient matrix and  $C_i$  is a detailed coefficient matrix.

The approximates and detailed coefficients of the line voltages  $V_{AB}$ ,  $V_{BC}$  &  $V_{CA}$  are denoted by  $A_{AB}$ ,  $A_{BC}$ ,  $A_{CA}$  &  $C_{AB}$ ,  $C_{BC}$ ,  $C_{CA}$  respectively. For fault detection & classification we consider only detailed coefficients.

Let,  $C'_{AB} = \sum |C_{AB}|$ ,  $C'_{BC} = \sum |C_{BC}|$  and  $C'_{CA} = \sum |C_{CA}|$ . If  $C'_{AB}$ ,  $C'_{BC}$  and  $C'_{CA}$  are zeros then there is no fault on a balanced or unbalanced system. If any one of  $C'_{AB}$ ,  $C'_{BC}$  and  $C'_{CA}$  is zero then fault is on a system with balanced load. If  $C'_{AB}$ ,  $C'_{BC}$  and  $C'_{CA}$  are non zeros then fault will have occurred on a system with unbalanced load. Truth table for detecting whether load is balanced or not is given in Table 1.

Table 1.

Absolute sum of coefficients during fault	System load
If $C'_{AB} = 0$ OR $C'_{BC} = 0$ OR $C'_{CA} = 0$	Balanced
If $C'_{AB} \neq 0$ OR $C'_{BC} \neq 0$ OR $C'_{CA} \neq 0$	Unbalanced

To identify faulty line we find minimum of  $C'_{AB}$ ,  $C'_{BC}$  and  $C'_{CA}$ . Faulty line will be a line that is not in minimum. Fault detection truth table for a balanced load and unbalanced load condition is given in Table 2.

Table 2.

Absolute sum of coefficients	Fault detection		
	Line A	Line B	Line C
$MIN(C'_{AB}, C'_{BC}, C'_{CA}) = 0$	NF	NF	NF
$MIN(C'_{AB}, C'_{BC}, C'_{CA}) = C'_{AB}$	NF	NF	F
$MIN(C'_{AB}, C'_{BC}, C'_{CA}) = C'_{BC}$	F	NF	NF
$MIN(C'_{AB}, C'_{BC}, C'_{CA}) = C'_{CA}$	NF	F	NF

NF  $\rightarrow$  Absence of fault. F  $\rightarrow$  Presence of fault

### 3 Implementation

#### 3.1 Integrated Power System (IPS) MATLAB SIMULINK Model

The typical Integrated Power System [1, 21-22], consists of an ungrounded 3-phase generator, ungrounded 3-phase transformer, 3-phase rectifier, buck converter, 3-phase inverter and ungrounded load as shown in figure 2(a).

In this paper typical integrated power system of navy ships is modeled in MATLAB SIMULINK whose details are as shown in figures 3.1(b-f).

#### Testing

For testing the proposed method, in the above model fault is created between line and ship hull at load terminals as shown in figure 3.1(f). The line voltages,  $V_{AB}$ ,  $V_{BC}$  and  $V_{CA}$  at load terminals are used to detect the faults.

#### Example 1. Balanced load

For balanced load,  $R_A$ ,  $R_B$  and  $R_C$  are set equal to  $0.48 \Omega$  in load model of figure 3.1(f). System without fault is considered in case - I and system with fault between line-A and ship hull at 0.2101 s with a duration of 0.1 ms, near load terminals is considered in case - II.

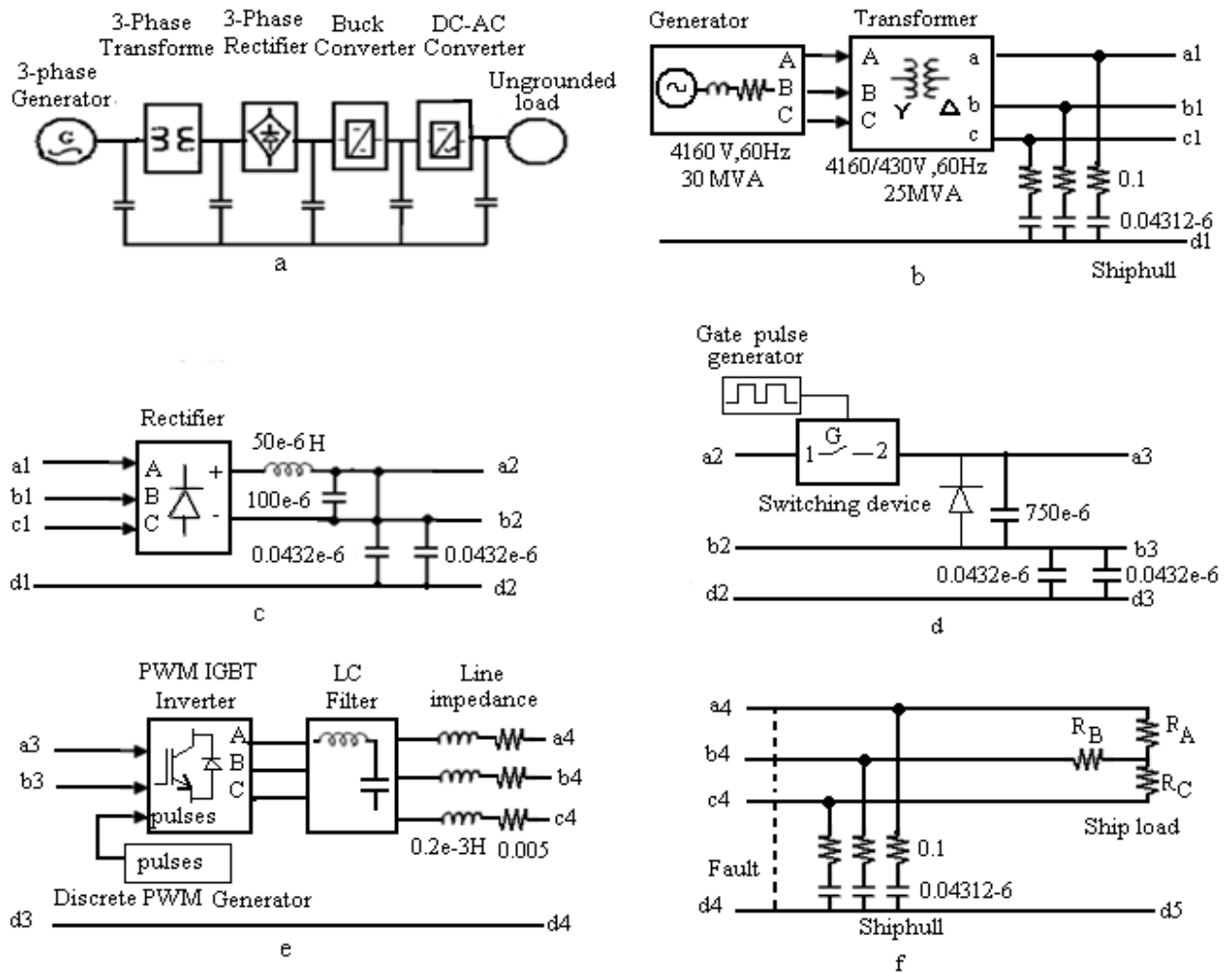

Fig. 2 (a). A integrated power system. (b). Generator, transformer and line to ship hull capacitance with internal resistance. (c). Bridge rectifier, LC-filter and line to ship hull capacitance. (d). One quadrant chopper and line to ship hull capacitance. (e). PWM inverter, LC- filters and line impedance. (f). Line to ship hull capacitance and ship load resistances,  $R_A$ ,  $R_B$  and  $R_C$ .

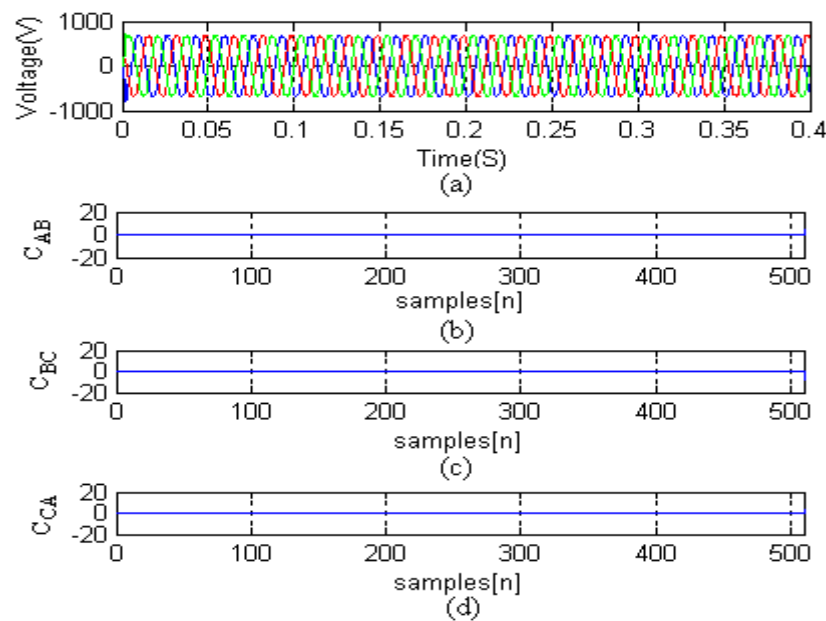

Fig. 3 (a) Line voltages with no fault and balanced load. (b) Wavelet decomposition of line AB voltage ( $V_{AB}$ ). (c) Wavelet decomposition of line BC voltage ( $V_{BC}$ ). (d) Wavelet decomposition of line CA voltage ( $V_{CA}$ ).

### Case I. Without fault

Here our aim is to detect the absence of fault by proposed method for ungrounded power system with balanced load. In this method line voltages  $V_{AB}$ ,  $V_{BC}$  and  $V_{CA}$  at load terminals shown in figure 3 (a) are used for the purpose.

The order of signal  $x[n]$  ( $V_{AB}$ ,  $V_{BC}$  and  $V_{CA}$ ) is  $4096 \times 1$  and Daubachies wavelet coefficient matrix of order  $4098 \times 4096$  are used to get the detailed coefficients,  $C_{AB}$ ,  $C_{BC}$  and  $C_{CA}$  of  $V_{AB}$ ,  $V_{BC}$  and  $V_{CA}$  respectively ,at fourth level of resolution shown as in figure 4.2.1(b-d).

By observation of figure 3.2.1(b-d) all the coefficients are zeros. Also by calculation,  $C'_{AB} = 0$ ,  $C'_{BC} = 0$  and  $C'_{CA} = 0$ , therefore the fault does not exist between any of the lines and ship hull.

### Case II. With fault

The line voltages  $V_{AB}$ ,  $V_{BC}$  and  $V_{CA}$ , at load terminals with fault are shown in figure 4(a). Comparing these voltages with voltages in figure 3(a), it is difficult to detect the presence of fault. Applying the wavelet transform for the signal in figure 4(a), we get  $C_{AB}$ ,  $C_{BC}$  and  $C_{CA}$  as shown in figure 4(b-d). By calculation ,  $C'_{AB} = 19.58$ ,  $C'_{BC} = 0.00$  and  $C'_{CA} = 19.57$ . Since,  $C'_{BC}$  is minimum, the fault exists between line A and ship hull.

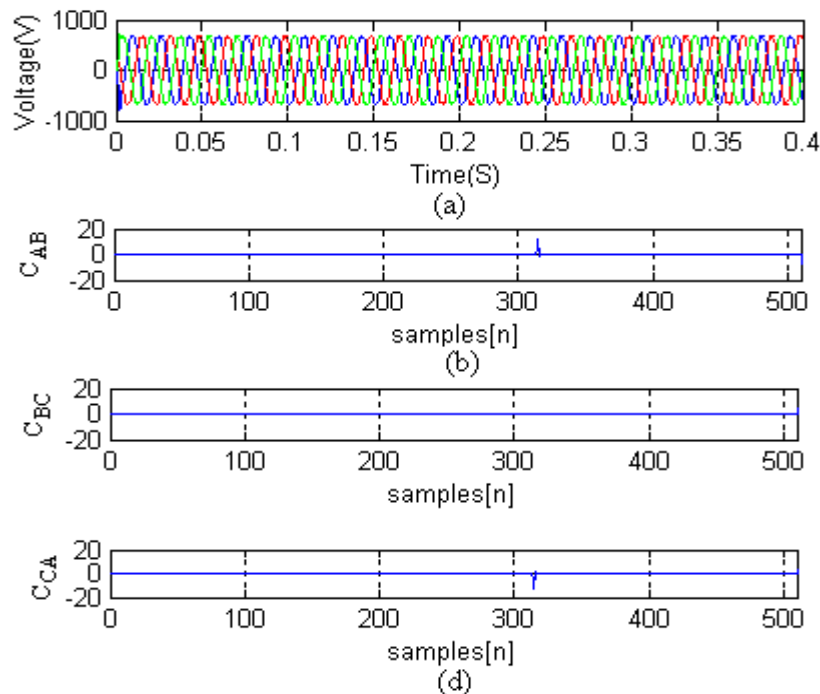

Fig. 4(a) Line voltages with fault between line A and ship hull when load is balanced. (b) Wavelet decomposition of  $V_{AB}$ . (c) Wavelet decomposition of  $V_{BC}$ . (d) Wavelet decomposition of  $V_{CA}$ .

### Example 2. Unbalanced load

To make the system unbalanced, ship load resistances are set as,  $R_A = 0.48 \Omega$ ,  $R_B = 0.6 \Omega$  and  $R_C = 0.7 \Omega$  in the simulation model. For testing the proposed method, system without fault is considered in case -III and a fault is created between line-A and ship hull at 0.2101 s with a duration of 0.1 ms, near load terminals in case -IV .

### Case III. Without fault

The line voltages  $V_{AB}$ ,  $V_{BC}$  and  $V_{CA}$ , at load terminals, shown in figure 5(a) are used to detect the absence of fault. The  $C_{AB}$ ,  $C_{BC}$  and  $C_{CA}$  for this case are shown in figure 5(b-d). It is observed that all the coefficients are zeros . By calculation it is found that  $C'_{AB} = 0$ ,  $C'_{BC} = 0$  and  $C'_{CA} = 0$ . Therefore, in this case fault does not exist between any of the lines and ship hull.

### Case IV. With fault

The line voltages  $V_{AB}$ ,  $V_{BC}$  and  $V_{CA}$ , at load terminals with fault are shown in figure 6(a). Comparing figure 6(a) with figure 5(a), it is difficult to detect the presence of fault. By application of wavelet transform

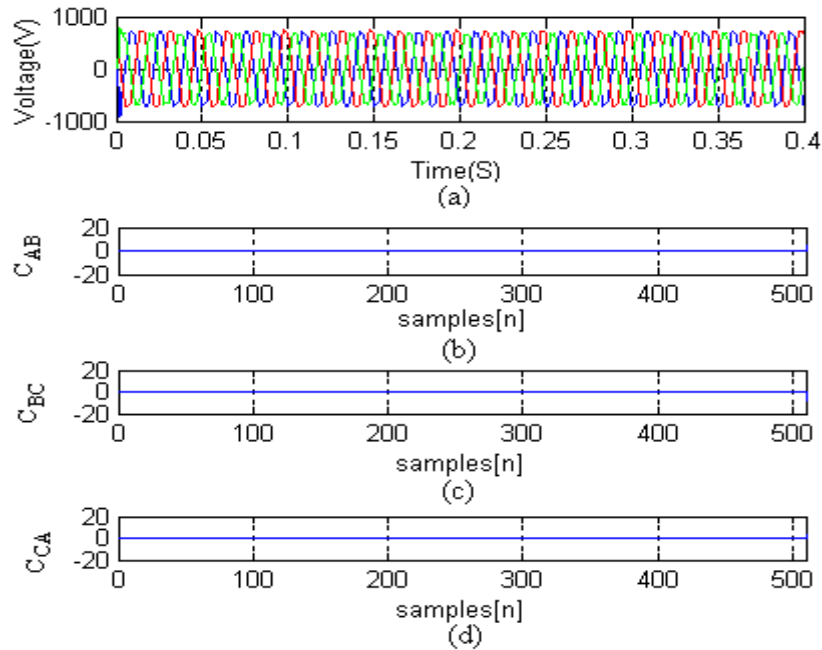

Fig. 5(a) Line voltages without fault and unbalanced load. (b) Wavelet decomposition of  $V_{AB}$ . (c) Wavelet decomposition of  $V_{BC}$ . (d) Wavelet decomposition of  $V_{CA}$ .

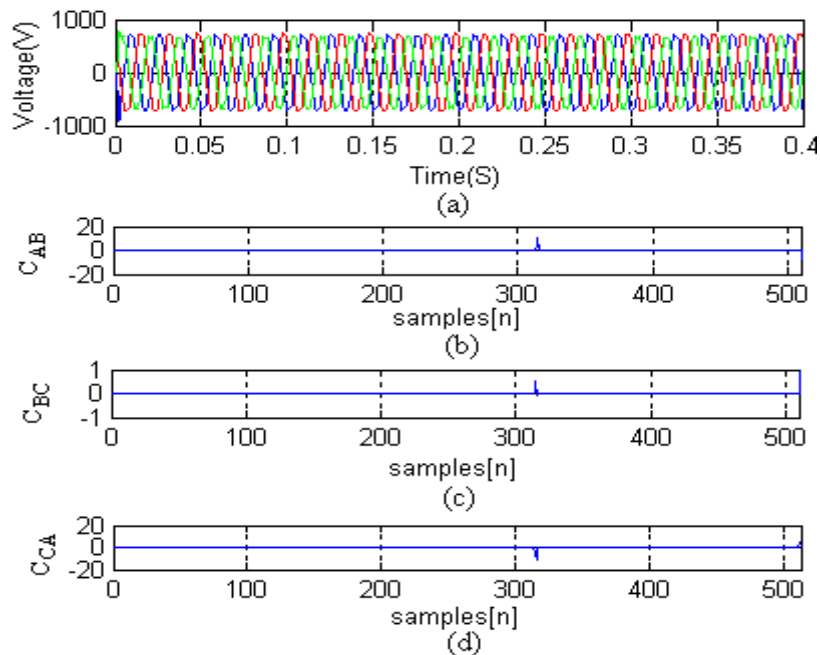

Fig. 6(a) Line voltages with fault between line A and ship hull when load is unbalanced. (b) Wavelet decomposition of  $V_{AB}$ . (c) Wavelet decomposition of  $V_{BC}$ . (d) Wavelet decomposition of  $V_{CA}$ .

To signal in figure 6(a), we get  $C_{AB}$ ,  $C_{BC}$  and  $C_{CA}$  as shown in figure 6(b-d). By calculation,  $C'_{AB} = 17.36$ ,  $C'_{BC} = 0.7648$  and  $C'_{CA} = 18.0921$  are non zeros which indicate integrated power system is unbalanced. Also,  $C'_{BC}$  is minimum therefore fault exists between line A and ship hull. The truth tables formulated based on above analysis is given below.

## 6. Conclusions

Wavelet transform is a powerful tool for non-stationary signals analysis. It provides time localization of the signal that will have a resolution that depends on the level in which they appear. Therefore, it is a good candidate for detection and localization of short time disturbances. In this paper the Daubechies wavelets ( $DB_4$ ) discrete wavelet transform based method is applied to the shipboard integrated power system for the detection of faults in a balanced and unbalanced ungrounded power system. It has been shown that wavelet analysis can be used to detect line to

ground (ship hull) faults. A proposed method of fault discrimination that determines the fault location is presented and applied to the identification of single line to ground fault scenarios.

## Appendix

### System parameters

Generator	: 4160V, 25MVA, 60Hz
Transformer	: 4160/430V, 25MVA, $R_2(\text{PU})=0.001$ , $R_2(\text{PU})=0.01$ , $R_m(\text{PU})=200$ , $X_m(\text{PU})=200$ .
Chopper	: Switching frequency of 4 KHz, duty cycle of 80%.
Inverter	: Sinusoidal PWM with a M.I. of 0.9 and switching frequency of 4 KHz.
LC-filter	: 50mH, 1000 $\mu$ F.

### References:

- [1] Doerry, H. Norbert and J. C. Davis, "Integrated Power System for Marine Applications," *Naval Engineers Journal*, volume 106(3), May(1994),77-90.
- [2] Petry, R. Chester, and W. Jay, Rumberg, "Zonal Electrical Distribution Systems: An Affordable Architecture for the Future", *Naval Engineers Journal*, volume 105(3), (1993), 45- 51.
- [3] R. Polikar, "Wavelet Transform: An advanced tool for analyzing non-stationary harmonic Distortions in power system", *IEEE Int. Conf. on Harmonics in Power Systems (ICHPS)*, volume 6, Bologna, Italy, (1994), 21-23.
- [4] P. Pillay, A. Bhattacharjee, "Application of Wavelets to Model Short Term Power System Disturbances", *IEEE Trans. on Power System*, volume.11(4), (1996), 2031–2037.
- [5] D. C. Robertson, O. I. Camps, J. S. Mayer, W. B. Gish, "Wavelets and Electromagnetic Power System Transients", *IEEE Trans. on Power Deliv.* volume 11(2), (1996), 1050–1057.
- [6] W. A. Wilkinson and M. D. Cox, "Discrete Wavelet Analysis of Power System Transients", *IEEE Trans. On Power System*, volume 11( 4), (1996), 2038–2044.
- [7] S. Huang, C. Hsieh, C. Huang, "Application of Morlet Wavelets to Supervise Power System Disturbances, *IEEE Trans. on Power Deliv.* Volume.14(1),(1999),235-243.
- [8] Shyh-Jier Huang, Cheng-Tao Hsieh and Ching-Lien Huang , " Application of Wavelets to Classify Power system Disturbances", *Electric Power Systems Research*, Volume 47(2), 15 October (1998), 87-93.
- [9] S. Santoso, E. J. Powers and W. M. Grady, "Power Quality Assessment via Wavelet Transforms Analysis", *IEEE Trans. on Power Deliv.* Volume11(2), (1996), 924-930.
- [10] W. Zhao, Y. H. Song and Y. Min. "Wavelet Analysis Based Scheme for Fault Detection and Classification in Underground Power Cable Systems", *Electric Power Systems Research*, Volume 53(1), 5 January (2000), Pages 23-30.
- [11] R. Polikar, "The Wavelet Tutorial", 1994. Retrieved on April 14, 2008 from <http://engineering.rown.edu/~polikar/Wavelets/Wttutorial.html>.
- [12] S. Mallat, "A Wavelet Tour of Signal Processing", *IEEE SP. Magazine*, October (1991), 14- 38.
- [13] C.H. Kim and R. Aggarwal, "Wavelets Transforms in Power Systems", *Power Engineering Journal*, Volume 15(4),(2001),193-202.
- [14] M. Vetterli, and J. Kovačević, "Wavelets and Subband Coding," Prentice Hall-PTR, Englewood Cliffs, New Jersey, (1995), 1- 488.
- [15] M.F. Akorede, and H. Hizam, "Wavelet Transforms: Practical Applications in Power Systems", *Journal of Electrical and Technology*, volume 4(2), (2009) 168-174.
- [16] N. M. Bujurke, S. C. Shiralashetti and C. S. Salimath, "An Application of Single Term Haar Wavelet Series in the Solution of Non-Linear Oscillator Equations", *Journal of Computational and App. Math.*, volume 227 (2), May(2009),234-244.
- [17] N. M. Bujurke, C. S. Salimath and S. C. Shiralashetti, "Numerical Solution of Stiff Systems from Non-Linear Dynamics using Single Term Haar Wavelet Series" *Int. J. of Nonlinear Dynamics*, volume 51(4),(2008), 595- 605.
- [18] N. M. Bujurke, C. S. Salimath, S. C. Shiralashetti, "Computation of Eigen values and Solutions of Regular Sturm-Liouville Problems using Haar Wavelets", *Journal of Computational and App. Math*, volume 219(1),(2008),90-101.
- [19] N. M. Bujurke, C. S. Salimath, R. B. Kudenatti, and S. C. Shiralashetti, "A Fast Wavelet-Multigrid Method to Solve Elliptic Partial Differential Equations", *Appl. Math. and Computation*, volume 185, (2007), 667-680.
- [20] N. M. Bujurke, C. S. Salimath, R. B. Kudenatti, and S. C. Shiralashetti, "Analysis of Modified Reynolds Equation using Wavelet- Multigrid Scheme", *An Int. J. of Numerical Methods for Partial Differential Equations*, volume 23, (2007),692-705.
- [21] N. Doerry, H. Robey, J. Amy, C. Petry, "Power the future with the integrated power System", *Naval Engineers Journal*, volume 108(3),May(1996) 267-282.
- [22] J. Lewis Blackburn, *Protective relaying: principles and applications*, Marcel, Dekker, Inc, New York, 1987.