

A Decoupled Parameters Estimators for in Nonlinear Systems Fault diagnosis by ANFIS

B. Bellali, A. Hazzab, I. K. Bousserhane, Dimitri Iefebvre

CAOEES laboratory

University of Bechar B.P 417 Bechar Algeria

GREAH laboratory le havre University

Article Info

Article history:

Received Dec 26th, 2011

Revised Feb 24th, 2012

Accepted Mar 28th, 2012

Keyword:

ANFIS, Fault Diagnosis

Decoupled effect

Nonlinear Systems

Parameters estimation

ABSTRACT

This paper presents a new and efficient Adaptive Neural Fuzzy Inference Systems approach for satellite's attitude control systems (ACSs) fault diagnosis. The proposed approach formulates the fault modelling problem of system component into an on-line parameters estimation. The learning ability of the adaptive neural fuzzy inference system allow as to decoupling the effect of each fault from the estimation of the others. Our solution provides a method to detect, isolate, and estimate various faults in system components, using Adaptive Fuzzy Inference Systems Parameter Estimators (ANFISPEs) that are designed and based on parameterizations related to each class of fault. Each ANFISPE estimates the corresponding unknown Fault Parameter (FP) that is further used for fault detection, isolation and identification purposes. Simulation results reveal the effectiveness of the developed FDI scheme of an ACSs actuators of a 3-axis stabilized satellite.

Copyright © 2012 Institute of Advanced Engineering and Science.

All rights reserved.

Corresponding Author:

B. Bellali,

CAOEES laboratory

University of Bechar B.P 417 Bechar Algeria

Email: bellali_badre@yahoo.fr

1. INTRODUCTION

Faults lead to the degradation of the process or to its performance, because of changes in physical characteristics. Fault detection and isolation (FDI) of dynamical systems is used to assure system reliability and safety. FDI has obtained more and more attention in many areas such as nuclear systems, process control, and aerospace. The high reliability required in processes has created the necessity of early failures detection and diagnosis. In addition, the use of autonomous systems with minimum human interferences, inflates the importance of systematic FDI. Existing FDI approaches are generally separated into model-based and model-free approaches. Model-based approaches are based on the mathematical model of the process. Such approaches include different methods as parameters estimation, state observation or parity equations. The parameters estimation method reflect the occurrence of faults as changes in the values of the physical parameters, many literature deal with the use of qualitative approaches to estimate the physical parameters, the main problem in fault diagnosis with the parameters estimation is the inter effect of each fault occurrence in the estimation of the other parameters. This work use the quality of nonlinear mapping of the ANFIS in the parameters estimation for nonlinear systems, and use the large Competence of learning in the fault effect decoupling from the estimation of others parameters. This work presents and describes an innovative method that uses ANFIS estimators and includes it in diagnosis system for failure detection.

The failures in the ACS of spacecraft can be caused by malfunctions in components, actuators, and sensors due to unexpected interference or gradual aging of system components. These failures could result in higher energy consumption, loss of control and equipment operating problems. With increasing emphasis placed these days on energy efficiency and equipment reliability, there is a need for the development of

robust FDI tools that are capable of detecting and isolating any sensor, actuator or system component faults, so that remedial actions and recovery procedures could be taken as soon as possible [2].

In the present paper, a fault diagnosis approach to detect and estimate ACSs components faults is presented. The proposed solution provides a framework to detect, isolate, and estimate various faults in system components, using Adaptive Neural Fuzzy Inference Systems Parameter Estimators (ANFISPEs). The remainder of the current paper is organized as follows: Section 2 reviews the principle scheme of fault diagnosis system. Section 3 highlights dynamic modeling of the reaction wheel actuators. Section 4 discusses simulation results. Conclusions are drawn in Section 5.

2. FAULT DIAGNOSIS SYSTEM USING ANFIS PARAMETERS ESTIMATOR

The proposed scheme for FDI, illustrated in the figure 1, is structured in 3 parts. The first part is composed of ANFIS parameter estimator's bank that evaluates specific parameters according to input measurements and command signals. These parameters change when faulty behaviors occur. The second part is composed of nonlinear faulty models that work out the estimated output according to the parameter evaluation. The third part is a usual FDI block that detects and isolates faults.

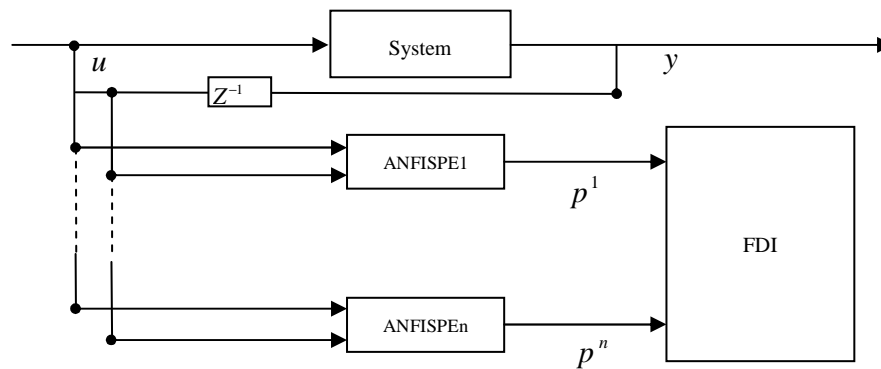

Figure.1. FDI with ANFISPE

3. ANFIS ARCHITECTURE

This section presents ANFIS parameters estimators (ANFISPEs). ANFISPEs estimate the physical parameters of the considered system based on given input–output patterns. ANFIS architectures can be employed to model nonlinear functions, identify on-line nonlinear components in a control system, and predict a chaotic time series [3]. As a consequence, we use ANFIS structures to generate signals that represent the faulty behaviors of the concerned systems according to the changes that occur in some physical parameters.

The usual ANFIS architecture uses a feed-forward network to search for fuzzy decision rules. Using a given input–output data set, ANFIS creates an fuzzy inference system (FIS) for which membership function. Parameters are tuned using either a back propagation algorithm alone or a combination of a back propagation algorithm and a least-squares method. Such a hybrid structure is useful to design FIS according to the collected data. For simplicity, we suppose that the FIS has two inputs x and y and one output f . The Takagi and Sugeno fuzzy models, a common rule set with two fuzzy “if-then rules” has the following expression (Figure 2):

$$\begin{cases} \text{Rule 1 : if } (x \text{ is } A_1) \text{ and } (y \text{ is } B_1) \text{ then } (f_1 = p_1x + q_1y + r_1) \\ \text{Rule 2 : if } (x \text{ is } A_2) \text{ and } (y \text{ is } B_2) \text{ then } (f_2 = p_2x + q_2y + r_2) \end{cases} \quad (1)$$

where A_1, A_2 and B_1, B_2 are respectively fuzzy sets of input premise variables x and y and p_1, q_1, r_1 and p_2, q_2, r_2 are parameters of the consequent or output variable.

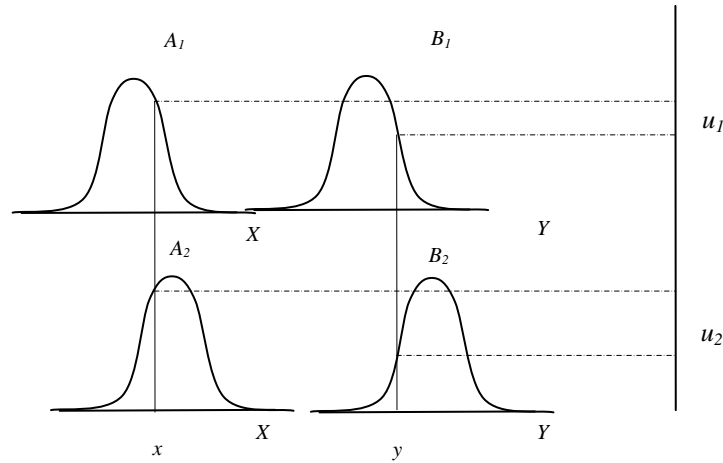

Figure 2. FIS with two rules

Let define $\mu_{A1}(x)$ and $\mu_{B1}(y)$ as the membership values respectively for “ x is A_1 ” and “ y is B_1 ” and work out $u_1 = \mu_{A1}(x) \mu_{B1}(y)$. Similarly $\mu_{A2}(x)$ and $\mu_{B2}(y)$ are the membership values for “ x is A_2 ” and “ y is B_2 ” and $u_2 = \mu_{A2}(x) \mu_{B2}(y)$. Then, the output is obtained as an aggregation of the qualified consequents:

$$f = \frac{u_1 f_1 + u_2 f_2}{u_1 + u_2} \tag{2}$$

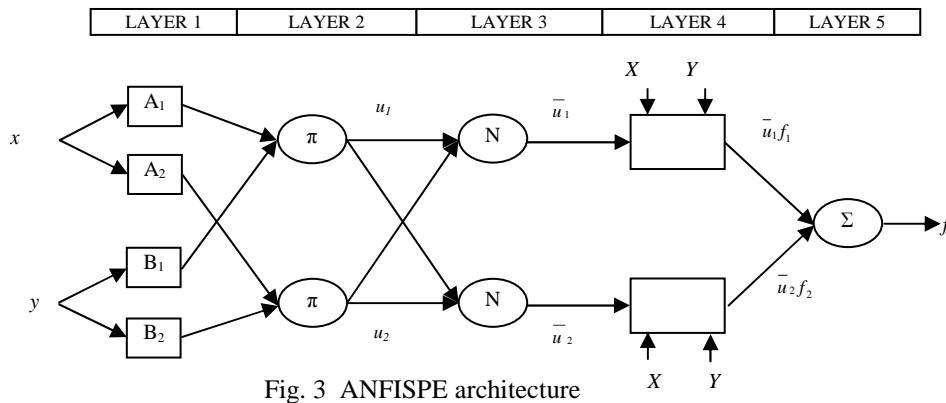

Fig. 3 ANFISPE architecture

The Figure 3 depicts the general structure of ANFIS, where the square nodes represent constant nodes and the circle ones are adaptive nodes, whose parameters are changed during the training process. The ANFIS structure is composed of functional blocks that are generated using a five layers network as it is described in the following section [4]:

3.1. Five-layer network ANFIS

Layer 1 (input layer): Each node of this layer generates membership grades for inputs.

$$O_i^1 = \mu_{A_i}(x) \quad i = 1, 2 \tag{3}$$

$$O_i^1 = \mu_{B_{i-2}}(y) \quad i = 3, 4 \tag{4}$$

where x, y are the crisp inputs to node i , and A_i, B_i are the linguistic labels characterized by appropriate membership functions, $\mu_{A_i}(x), \mu_{B_i}(x)$ respectively. Due to smoothness and concise notation, the Gaussian and

bell-shaped membership functions are increasingly popular for specifying fuzzy sets. In this layer, the functions of the nodes are Gaussian membership functions (GaussMF):

$$\begin{aligned} \mu_{A_i}(x) &= \exp \left[- \left(\frac{x - c_i}{a_i} \right)^2 \right] \\ \mu_{B_i}(x) &= \exp \left[- \left(\frac{y - d_i}{e_i} \right)^2 \right] \end{aligned} \quad i = 1, 2 \quad (5)$$

with the set of parameters $\{a_i, d_i, c_i, e_i\}$. as the values of these parameters change, the bell-shaped functions vary accordingly.

Layer 2 (rule layer): In the second layer, the AND operator is used to work out the output of the concerned rule. This output represents the firing strength (i.e. degrees to which the antecedent part of the fuzzy rule is satisfy) and shapes the output function for the rule. Hence the outputs u_1 and u_2 of this layer are the products of the corresponding degrees from Layer 1

$$u_i = \mu_{A_i}(x) \mu_{B_i}(x), \quad i = 1, 2 \quad \text{and} \quad j = 1, 2 \quad (6)$$

Layer 3 (average layer): In the third layer, the main objective is to calculate the firing strength ratio for each rule. Consequently, the output of layer 3 is the normalized firing strength:

$$\bar{u}_i = \frac{u_i}{u_1 + u_2} \quad i = 1, 2 \quad (7)$$

Layer 4: (consequent layer): The fourth layer computes the contribution of each rule to the overall FIS output. The dimension of this layer corresponds to the number of fuzzy rules in the system. Every node in this layer is a square node with a linear function whose form is defined by:

$$o_i^4 = \bar{u}_i f_i = \bar{u}_i (p_i x + q_i y + r_i), \quad i = 1, 2 \quad (8)$$

where \bar{u}_i are the output from the previous layer. $\{p_i, q_i, r_i\}$ are the parameters of the linear combination. Layer 5 (output layer). The single node computes the overall output by summing all the incoming signals. Accordingly, the defuzzification process transforms the fuzzy result into a crisp output:

$$f = \sum_i \bar{u}_i f_i = \bar{u}_1 f_1 + \bar{u}_2 f_2 = \frac{u_1}{u_1 + u_2} f_1 + \frac{u_2}{u_1 + u_2} f_2 \quad (9)$$

The ANFIS networks need to be trained with the collected data. The training phase is a process that determines the optimum value of parameters so that ANFIS successfully fits the training data [5].

The proposed ANFIS combines two techniques in updating parameters. For premise parameters that define membership functions, ANFIS employs a gradient-based optimization algorithm. For consequent, parameters that specify the output equations, ANFIS uses the least-squares method. This approach is thus called hybrid learning method [6] since it combines the gradient-descent method and the least-squares method.

a Hybrid learning algorithm

When the premise parameters are not constant, the search space becomes large, and the convergence of training may be slow. The hybrid-learning algorithm is adopted to solve this problem. This algorithm is a two-step process. [7]:

(1) The consequent parameters are identified using the least-squares algorithm after the initial premise parameters are determined, based on the equation:

$$f = (\bar{u}_1 x) p_1 + (\bar{u}_1 y) q_1 + (\bar{u}_1) r_1 + (\bar{u}_2 x) p_2 + (\bar{u}_2 y) q_2 + (\bar{u}_2) r_2 = A X \quad (10)$$

The consequent parameters $\{p_1, q_1, r_1, p_2, q_2, r_2\}$ are summed up in of column vector X . The matrix A and vector f result from a training set of size $K \{(x_i, y_i, f(x_i, y_i)), I = 1, \dots, K\}$:

$$A = \begin{pmatrix} \bar{u}_1 & x_1 & \bar{u}_1 y_1 & \bar{u}_1 & \bar{u}_2 x_1 & \bar{u}_2 y_1 & \bar{u}_2 \\ \vdots & \vdots & \vdots & \vdots & \vdots & \vdots & \vdots \\ \bar{u}_1 & x_k & \bar{u}_1 y_k & \bar{u}_1 & \bar{u}_2 x_k & \bar{u}_2 y_k & \bar{u}_2 \end{pmatrix}, f = \begin{pmatrix} f(x_1, y_1) \\ \vdots \\ f(x_k, y_k) \end{pmatrix} \quad (11)$$

The optimal approximation X^* of the consequent vector X is obtained with:

$$X^* = (A^T A)^{-1} A^T f \quad (12)$$

and the least mean square error is $\min \|AX - f\|$ for X anywhere in search space.

- (2) This resulting error is transmitted from the output of layer 4 to the input of layer 4 reversely based on BP algorithm of feed-forward neural network. Such back propagation process is used to update the premise parameters with gradient-descent method, and consequently to change the shape of membership functions.

b Faulty model design

In this section, we describe the system's nonlinear faulty model, it is modeled by the state space equation (13) where x is the state vector, f is the state function, h is the output function and d represents the system disturbances that are assumed to be a bounded signal.

$$\begin{cases} \dot{x} = f(x, u, p) + d \\ y = h(x) \end{cases} \quad (13)$$

In this paper, following the work of Iserman [8], system component faults are reflected in the physical systems parameter degeneration. Hence faults occurrence is represented by changes in the fault parameter vector's p of the system. When the system is healthy, p takes the nominal value of the physical parameters. In faulty cases, the value of p depends on the way that the faults disturb the system. We assume in this paper that faults affect the physical parameters in additive form. The faulty model given by equation (13) is used to transform the problem of nonlinear fault diagnosis in an on-line nonlinear parameter estimation problem, for which unknown fault parameters are estimated using system inputs and measurements.

3.2. Fault Detection And Estimation With ANFISPEs

The proposed fault detection scheme is achieved firstly by the estimation of the fault parameter vector, using system input-output measurements. For fault isolation, we propose to use a bank of parameter estimators where each estimator is designed for a single parameter fault as described below. Consider the general parameter fault model given in equation (13) with n fault parameters (length of p). We extract n single parameter model from the model (13). The bank of n parameter estimators is designed on each separate fault model given by equation (14), where the i th parameter estimator will essentially estimate the i th fault parameter.

$$\begin{cases} \dot{x} = f(x, u, p^i) + d \\ y = h(x) \end{cases} \quad (14)$$

For nonlinear systems, the parameter estimation is commonly achieved though the Extended Kalman Filter (EKF) [9] used as a standard technique for recursive estimation. Such method suffers from suboptimal performance and sometimes model divergence due to errors introduced by first-order approximation of the nonlinear dynamics. To overcome this limitation in parameter's estimation for a disturbed nonlinear system, we integrate the ANFIS with the nonlinear dynamical model of the system. The

estimation of parameters is then based on a minimization of instantaneous output estimation error. The choice of ANFIS is motivated by their good approximation properties for nonlinear systems.

The bank of ANFISPEs is composed of two subsystems; the nonlinear faults models given by (14) employed for state estimation and the ANFISPE used for adaptively approximate the nonlinear Fault parameter function. Therefore, at each time instant, each ANFISPE in the bank should perform the the estimation of the p element in the faulty parameter vector, that represent the estimation of i th fault parameter using the current and previous instant value of inputs and outputs measurements respectively.

4. DYNAMIC MODELING OF REACTION WHEEL ACTUATORS

To judge the performance of this fault diagnosis scheme, we consider the problem of detection, isolation and estimation of faults in Reaction Wheel actuators components, in a satellites Attitude Control System (ACS). Developing an accurate and efficient fault diagnosis in reaction wheel components become a challenging problem due to the inherent nonlinearity of reaction wheel and satellite attitude dynamics and presence of disturbances exerting on satellite body. The selection of the reaction wheel platform is motivated by stringent requirements on satellites to operate autonomously in presence of faults in sensors, actuators and components. Moreover, the large number of reported publications [10], [11], [12] on this topic over the recent years provides further evidence of the importance of the application. To assess the performance of our proposed FDI scheme in a near-realistic environment, we use the MATLAB-Simulink tools to develop an accurate simulation model of a 3-axis stabilized satellite.

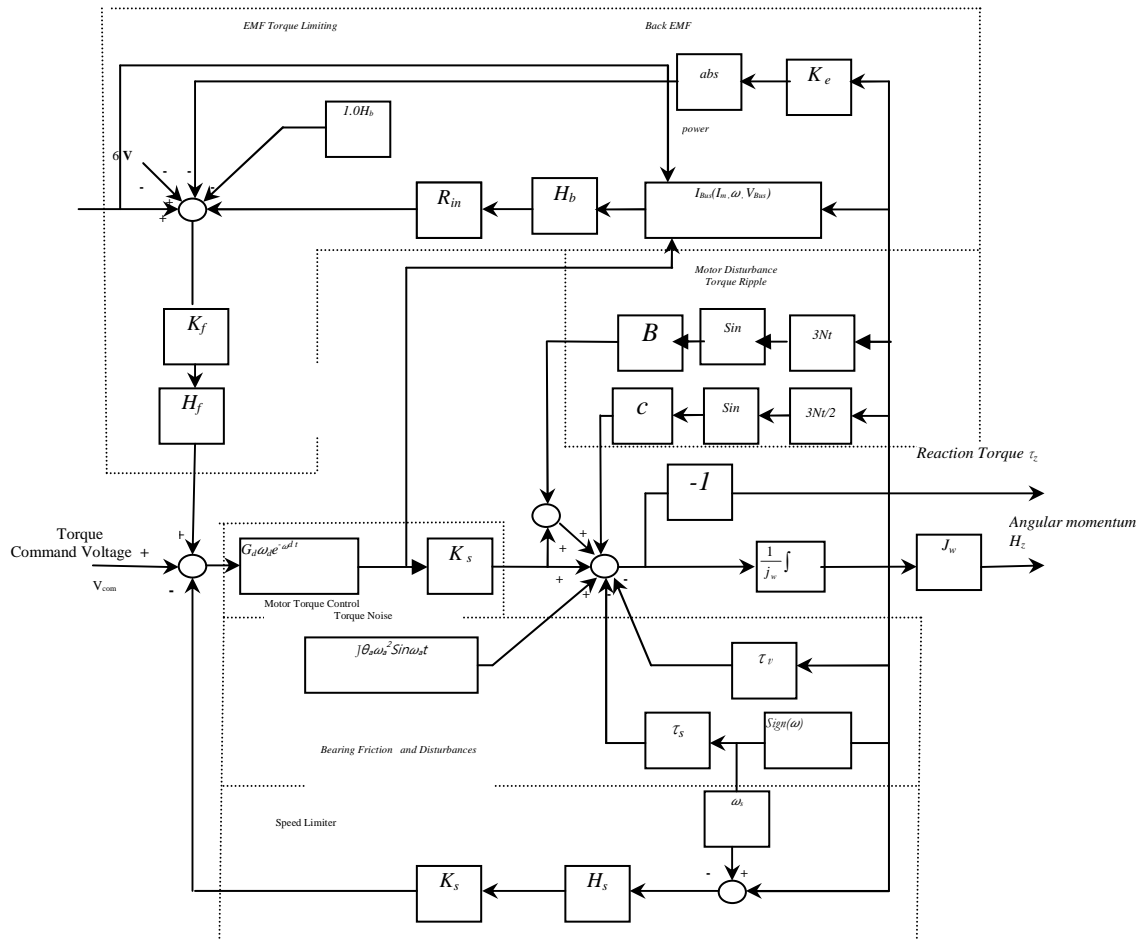

Fig 4. Detailed Reaction Wheel Bloc Diagram

The simulation model consists of the well-known nonlinear satellite attitude dynamics [13], a high fidelity nonlinear model of the reaction wheel [14] and decentralized PID controllers that stabilize the closed-loop system so that the control input signals and the state vector remain bounded prior to and after the

occurrence of a fault. Furthermore, nonlinear Euler transformations are applied to transform the satellite angular velocities to Euler angle rates, namely roll, pitch, and yaw. The high-fidelity model of a reaction wheel (RW), given in the block diagram in Figure 4, incorporates all the nonlinearities as well as internal disturbances that are present in a real RW actuator. The closed-form nonlinear state-space representation of a reaction wheel model may be expressed as follows:

$$\begin{bmatrix} \dot{I}_m \\ \dot{\omega} \end{bmatrix} = \begin{bmatrix} G_d \omega_d [\psi_1(I_{bus}, \omega) - \psi_3(\omega)] - \omega_d I_m \\ \frac{1}{J} [K_t I_m (1 + B\phi_1(\omega, t)) - \tau_c \psi_2(\omega) - \tau_v \omega + C\phi_2(\omega, t)] \end{bmatrix} + \begin{bmatrix} G_d \omega_d \\ 0 \end{bmatrix} V_{com} \quad (15)$$

where I_m (the current) and ω (the angular velocity) are the measured states of Reaction Wheel, V_{Com} is the input command voltage signal of RW, generated by the PID controller in the closed-loop attitude control system. ψ_1, ψ_2, ψ_3 are nonlinear functions modeling EMF torque limiting, coulomb friction, and speed limiter subsystems, respectively. I_{bus} a highly nonlinear function of states and the bus voltage V_{bus} , and ϕ_1, ϕ_2 are representing torque ripple and cogging respectively [14]. The objective is to detect, isolate and estimate the severity of possible faults in RW components using Reaction wheel signals.

Thus, measurements of RW current and angular velocity together with the wheel command voltage comprise the input vector of the ANFISPE. Our objective is to detect, isolate and estimate the faults in two components of reaction wheel, bus voltage V_{bus} , and motor gain, K_t , both have been identified as major sources of faulty behavior in reaction wheels [14]. It should be accentuated. The corresponding faulty behavior can be represented as an additional signal in the form of a single-parameter fault model for each physical parameter (single fault case) given in the following equation [14].

5. SIMULATION RESULTS

The simulations have been performed by using nonlinear models of the reaction wheel and the attitude dynamics of a 3-axis stabilized satellite. The closed-loop satellite attitude control system was stabilized using three decentralized PID controllers. The simulation data are obtained from the closed-loop ACS of satellite simulation, with a run-time of 2000s. Many reference steps are commanded to the satellite in the Pitch channel. The satellite body is under a random torque disturbance action with the maximum norm of 10⁻⁴ N·m. The nonlinear model in the healthy mode ($K_t = 0.029$, $V_{bus} = 24V$), the parameters of the reaction wheel are adopted from Bialke [14] for the ITHACO's standard type 'A' reaction wheels. Firstly in this simulation the system Submit to an irregular fault with a strong amount over the] 450 950] time interval in the motor gain. In consequence, we suppose that the faults affect the motor parameter in additive form as follows:

$$\begin{cases} K_t = 0.029 & 0 \leq t < 450 \\ K_t = 0.014 & 450 \leq t < 950 \\ K_t = 0.029 & 950 \leq t < 2000 \end{cases} \quad (16)$$

The results of our simulation are depicted in the figure 5 and figure 6 we can show the effect of the injected fault in the behavior of the reaction wheel actuator in the measurement values of the wheel's angular velocity degradation and the motor's current consumption. We note the significant impact of the introduced motor gain faults on the reaction wheel states. The K_t ANFISPE provide a good estimation of the effective motor gain value we can show the close match between the injected and the estimated motor gain value during all the concerned interval in the figure 7, moreover the estimation of V_{bus} value do not diverge from the effective one and the V_{bus} ANFISPE provide a good estimation. So the effect of the K_t fault doesn't touch the efficiency of the V_{bus} ANFISPE as it can be seen in the figure 8 in the studded time interval.

Next, in time interval [950 1450] we inject the nominal values of the RW's parameters in order to obtain the healthy behavior of the system and we find the healthy states of the RW actuator. In the follow time interval [1450 2000] the satellite submit to an additive form of fault, the following equation represent the Bus Voltage behavior:

$$\begin{cases} V_{bus} = 24 & 0 \leq t < 1450 \\ V_{bus} = 18.4 & 1450 \leq t < 2000 \end{cases} \quad (17)$$

As can be seen from the Figure 5 and 6, the measurements of RW states suffer clearly from the V_{bus} drop and the behavior of the actuator become degraded states. The K_t ANFISPE's estimated value doesn't become infected by the V_{bus} drop and the performance of this estimator can reject the effect of the V_{bus} fault occurrence as it can be shown in the figure 7. In the other ANFISPE we can see from the figure 8 that the estimated value of V_{bus} present a very close match with the injected one and the error of estimation can be neglected, we can see that the estimation follow the drop of the Bus Voltage as well as required.

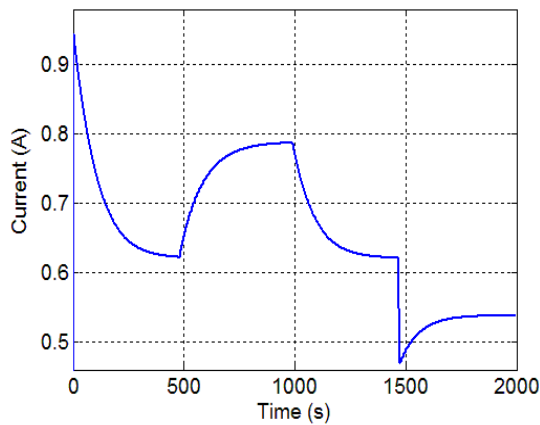

Fig. 5. Fault on Angular velocity of reaction wheel actuator

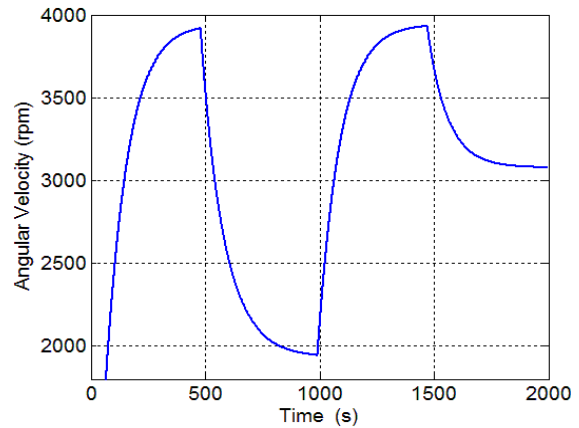

Fig. 6. Fault on Angular velocity of reaction wheel actuator

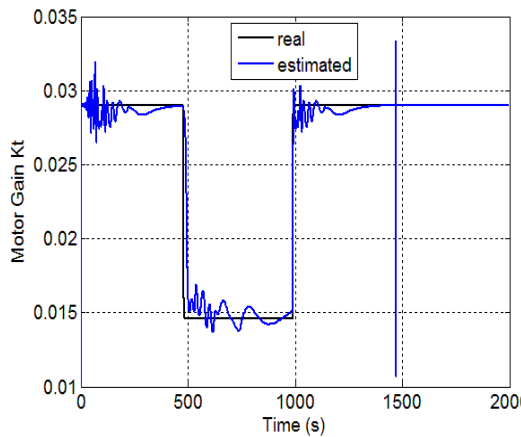

Figure 7. Fault on Angular velocity of reaction wheel actuator

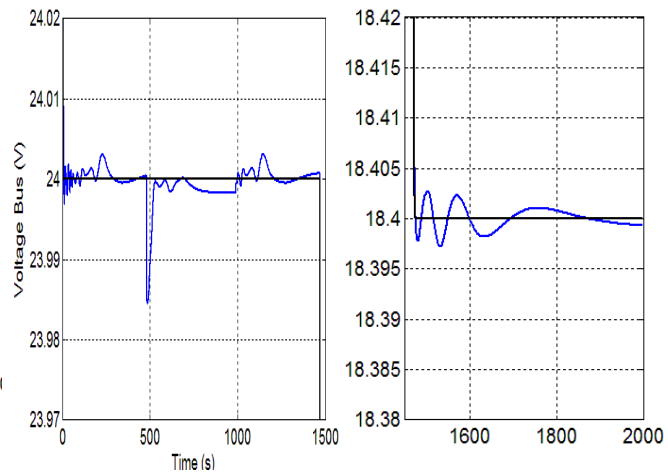

Figure 8. Fault on Angular velocity of reaction wheel actuator

6. CONCLUSION

In this research, a new solution based on the neural fuzzy inference system (ANFIS) is proposed and presented to achieve the objectives of fault detection, isolation in a satellite's ACS nonlinear system with the states measurement. This approach is based on two ANFIS parameter estimators where each fault parameter is representative of a specific kind of system component fault. Such method allows fault isolation with minimum residual signal processing. Simulation results show the effectiveness of this method in estimation of the effective value of physical parameters, of two types of component faults in reaction wheel actuators of

a satellite's attitude control system. Consequently in fault diagnosis and estimation of two types of component faults. Inferential physical parameters observer is a very effective tool to detect the malfunction of nonlinear satellite's ACS. The learning ability of the adaptive neural fuzzy inference system allows us to decoupling the effect of each fault from the estimations of the others and the results obtained present very interested tools for the faults isolations. Moreover, the time processing for fault diagnosis becomes a very small as possible.

REFERENCES

- [1]. E. Sobhani-Tehrani, K. Khorasani, S. Tafazoli, Dynamic Neural Network-based Estimator for Fault Diagnosis in Reaction Wheel Actuator of Satellite Attitude Control System, Proc. Int. Joint Conf. on Neural Networks, pp. 2347-2352, 2005.
- [2]. N. Tudoroiu and K. Khorasani. Fault Detection And Diagnosis For Reaction Wheels Of Satellite's Attitude Control System Using A Bank Of Kalman Filters, Proc of the 2005 IEEE Conf on Control Applications: 0-7803-9029-6
- [3]. J.S.R. Jang, : ANFIS adaptive-network-based fuzzy inference system, IEEE Transactions on Systems, Man, and Cybernetics 23 (1993)665–685.
- [4]. Fi-John Chang, : Adaptive neuro-fuzzy inference system for prediction of water level in reservoir Advances in Water Resources 29 (2006) 1–10
- [5]. Jang JSR, Sun CT, Mizutani E. Neuro-fuzzy and soft computing: a computational approach to learning and machine intelligence. N.J: Prentice Hall; 1997.
- [6]. [Zuperl Uros Adaptive network based inference system for estimation of flank wear in end-milling. journal of materials processing technology 209 (2009) 1504–1511
- [7]. Yuang-Shung Lee, Tsung-Yuan Kuo, Wei-Yen Wang. Fuzzy Neural Network Genetic Approach to Design the SOC Estimator for Battery Powered Electric Scooter. 2004 IEEE: 2759-27657
- [8]. Isermann, : Fault diagnosis of machines via parameter estimation and knowledge processing - a tutorial paper, Automatica, vol. 29, No. 4, pp. 815-835, 1994 (b).
- [9]. S. Haykin, Kalman filters, in: S. Haykin (Ed.), Kalman filtering and neural networks, Wiley/Interscience, New York, pp. 1-22, 2001.
- [10]. E. Sobhani-Tehrani, K. Khorasani, S. Tafazoli, "Dynamic Neural Network-based Estimator for Fault Diagnosis in Reaction Wheel Actuator of Satellite Attitude Control System," Proc. Int. Joint Conf. on Neural Networks, pp. 2347-2352, 2005.
- [11]. N. Tudoroiu and K. Khorasani, "Fault detection and diagnosis for reaction wheels of satellite's attitude control system using a bank of Kalman filters," Int. Symp. on Signals, Circuits and Systems, vol. 1, pp. 199-202, 2005.
- [12]. H. A. Talebi and R.V. Patel, "An Intelligent Fault Detection and Recovery Scheme for Reaction Wheel Actuator of Satellite Attitude Control Systems," IEEE Conf. on Control Applications, pp. 3282 – 3287, 2006.
- [13]. M. J. Sidi, Spacecraft Dynamics and Control : A Practical Engineering Approach, New York, NY, Cambridge University Press, 1997.
- [14]. B. Bialke, :High fidelity mathematical modeling of reaction wheel performance, in 21st Annual American Astronautical Society Guidance and Control Conference, February 1998. AAS paper 98-063.