

Final report - Oslo Operational Pilot



Subtitle: Vulkan Car Parking, Oslo, Norway

Authors: Prepared by Xuewu Dai, Richard Kotter, Ghanim Putrus, Yue Wang, Ridoy Das, Edward Bentley, Mousa Marzband (Northumbria University) and Jorden van der Hoogt (Stichting Cenex Nederland)

Date: 29/07/2020

Participants:

- Agency for Urban Environment, Oslo City Council: Sture Portvik
- Hogeschool van Amsterdam): Bronia Jablonska and Jos Warmerdam
- Katholieke Universiteit Leuven: Bert Herteleer
- Stichting Cenex Nederland: Esther van Bergen

With acknowledgements for information also to Goran Vollan, Snorre Sletfold Oskar Ekman (Fortum Charge & Drive), Björn Jernström (Ferroamp), and Isak Oksvold and Kjersti Volvik (Aspelin Ramm).

Document control

Version	Date	Authors	Approved	Comment
V1.0	28/07/2020	XD, RK, GP, YW, RD, EB, MM, JvdH	GP	Internal release SEEV4-City
V1.1	11/09/2020	RK, GP, SP, EvB, BH, JvdH, BJ, JW	GP	Final version for public release. Updated with feedback from partners and finalized layout





Executive Summary

This report provides a final report of the SEEV4-City Operational Pilot at the Vulkan parking garage in Oslo, Norway. It is part of a collection of reports published by the project covering a variation of specific and cross-cutting analysis and evaluation perspectives and spans across 6 operational pilots. This report is dedicated to the analysis of the pilot itself. Below is an indication of the set of reports provided, including an indication where this OP report fits in.

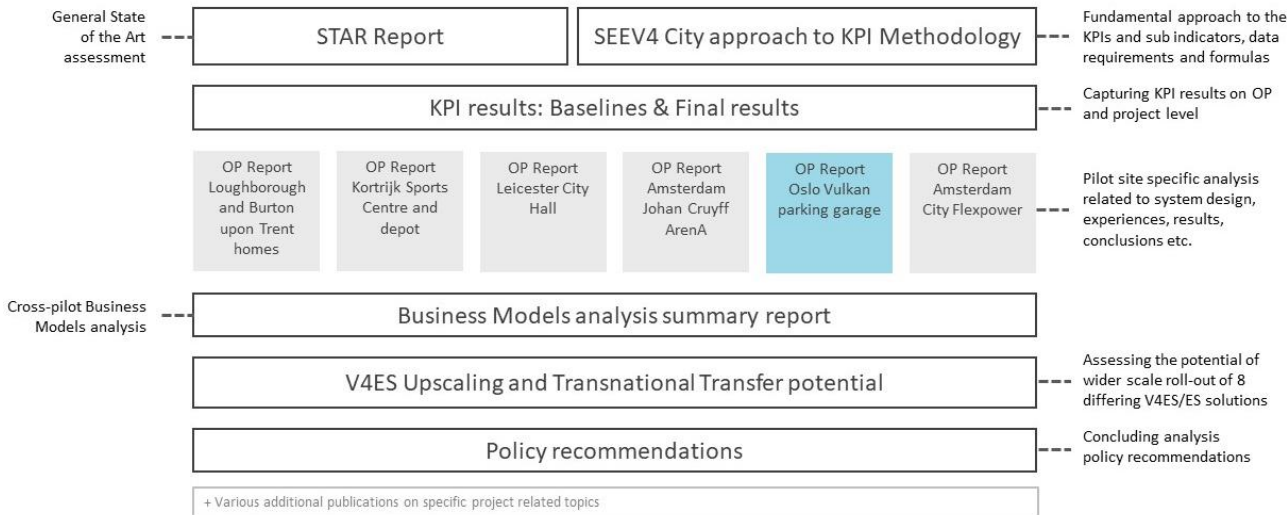

The Vulkan real estate site in Oslo is owned by Aspelin Ramm, and includes one of the largest parking garages used for EV charging in Europe. EV charging (both AC and DC) is managed for now predominately for costs reasons but also with relevance at further EV penetration level in this car parking location (mixed EV and ICE vehicles). This neighbourhood scale SEEV4-City operational pilot (OP) has 50 × 22 kW flexible AC chargers with two sockets each and two DC chargers of 50 kW with both ChaDeMo and CCS outlets. All EV chargers now have a smart control (SC) and Vehicle-to-Grid (V2G) functionality (though the latter may not be in place fully for DC chargers, as they may not be fully connected to the remote back-office system of the EV charging systems operator). A Lithium-ion Battery Energy Stationary Storage System (BESS) with a capacity of 50 kWh is pre-programmed to reduce the energy power peaks of the electric vehicle (EV) charging infrastructure and charges at other times from the central grid (which has a generation mix of 98% from hydro-electric power, and in the region covering Oslo also 1% from wind). The inverter used in the BESS is rated at 50 kW, and is also controlled to perform phase balancing of the 3-phase supply system.

The complete energy system was installed custom-built, and it is managed and monitored by Fortum (Charge & Drive). Fortum is the innovation partner of both Aspelin Ramm and Oslo City Council, and also other technology sub-contractors (such as Ferroamp for a stationary battery) have been involved in this OP. EV charging is currently free at night-time for residential parking (since Oslo City Council pays Aspelin Ramm for this, at least until mid-2022, in order to relieve the pressure on on-street public EV charging stations). Several car-sharing companies and an EV-to-go provision – as well as some (van-based) logistics service companies and electric taxis – are also making use of the parking garage during the day. These are alongside other users across the city paying for the parking and EV charging separately, and also residents of the neighbourhood at off peak and overnight times.

The Vulkan car parking garage has the largest AC charging provision in such a setting (in line with Oslo City Council’s overall strategy) in Oslo as well as in Norway, and in the North Sea Region (NSR) of Europe. Since this innovative technology system is from 2017, some limitations exist in the dynamic control of individual chargers, and the back-office connection of the two DC chargers. Different pricing structures for different AC charging speeds during the day have been experimented with, and have now been altered to a simplified charging tariff (which nonetheless varies how users connect to it by different technologies). Also, due to the success of attracting EV users to the car parking garage for charging their EVs, the capacity/sizing of the stationary battery (supporting the EV chargers collectively) is now rather marginal, and thus peak shaving of EV charging power demand is now proportionally more limited. Consequently, the electricity bill savings for the EV charging operator are also now proportionally reduced. However, electricity billing in the Norwegian regulatory context changed in the course of 2019, further towards a capacity-based rather than a purely volumetric calculation basis. This means that peak-shaving has become relatively more important in the Oslo and Norwegian context. Furthermore, whilst all of the AC chargers are now ‘V2G-ready’, this option for Electric Vehicle for Energy Services (EV4ES) has yet to be developed in the Norwegian policy and regulatory context.





The results are summarised in the table below, showing that the Operational Pilot exceeded the target for CO₂ emissions reduction by a comfortable margin (912 tons compared to 120 tons). The 4,210,405 zero km/year achieved represents a very significant increase factor, well above the original target of 1.5x which would correspond to 1,062,000 zero km/year. The initial indicated figure of 8% Energy Autonomy was not applicable as part of the baseline, as it was decided by the local OP partners that the PV installation was no longer part of the design set-up to be installed. No additional renewable energy generation was installed either, which means there was no increase in energy autonomy achieved for the Oslo Vulkan OP.

At the commencement of the project, peak demand value for EV charging was 64.9 kW. As a reflection of the success of the Vulkan car parking garage (contributing in a major way to clean transport in Oslo), at the end of the pilot (prior to COVID-19 restrictions affecting the use of the car parking garage), the peak demand for EV charging had risen to 378 kW. Whilst no actual grid investment deferral occurred during the OP itself, the OP demonstrated how the 50 kW BESS could be effective in reducing peak demand and deferring grid investment. Data available covers the period from when the BESS was first put in operation in February 2017 until March 2020. The BESS was configured such that if the total EV charging demand exceeds a pre-set threshold, the BESS would discharge to support the EV charging infrastructure, and if the EV charging demand drops below a pre-defined threshold the BESS would charge from the grid. The BESS was also set to do phase-balancing in addition to provide power to reduce peak demand.

Data collected showed that the peak demand at the commencement of the pilot occurred on 24th March 2017 and was 64.9 kW. Measured data showed that negligible BESS discharge actually occurred during the peak hour, which could be due to the way the system was set up (providing two functionalities, phase balancing and peak demand support). Examination of the data showed periods when the BESS was discharging 25 kW or even higher to support the grid, but the timing of this did not seem to be synchronized to the peak hours. Had the BESS system produced 25 kW at the appropriate time, peak demand would have been reduced by 38% (based on 64.9 kW peak demand). Obviously, the BESS is capable of supplying up to 50 kW, but we deduce that the maximum power is not usually used in order to protect the state of health of the battery (i.e. to prolong battery life).

Data collected showed that the highest peak charging demand of 378 kW was recorded on 23rd January 2020 (towards the end of the pilot). However, the contribution from the BESS was also negligible during the peak hour. 50 kW output power from the BESS sustained for the peak demand would have reduced this peak demand figure by about 13%. This reduction in peak demand reflects the deferral in grid reinforcement, as the required grid capacity is proportional to the peak demand.

According to the data examined, the BESS system did appear to act to reduce the grid demand within a given month, but was not necessarily reducing the highest peak demand (which is the basis for calculating the charge to be paid for maximum demand according to the electricity tariff used). If the peak demand in a given month could have been reduced by the BESS maximum output of 50 kW, then under the current (revised during 2019) Norwegian grid regulator system, there would have been 'Effektledd' savings of NOK 7500 for that month. This indirectly reflects a proportional deferral in grid reinforcement.

<i>Oslo Vulkan Operational Pilot – KPIs</i>			
<i>KPI</i>		<i>TARGET</i>	<i>RESULTS</i>
A	CO ₂ Reduction	90 – 120 tonnes annually	912 tons/year
	Sub-KPI: ZE km increase factor	1.5 x (i.e. 1,062,000 km/year)	5.95 (i.e. 4,210,405 km/year)
B	Energy Autonomy increase	from 8% to 10%	N/A
C	Grid Investment deferral (by peak demand reduction)	20% Peak reduction	13%





Table of Contents

EXECUTIVE SUMMARY	2
GLOSSARY	6
1. ABOUT THE PILOT	7
1.1. Background	7
1.1.1. Local context and energy profile	8
1.1.2. Local partners.....	10
1.1.3. Objectives and SEEV4-City KPI targets.....	11
1.1.4. System design.....	12
2. DATA COLLECTION AND PROCESSING	19
2.1. Assumptions and research questions	19
2.2. Data processing	19
2.2.1. Dataset 1 – EV chargers’ dataset.....	19
2.2.2. Dataset 2 – load profile	25
2.2.3. Dataset 3 – Ferroamp database.....	26
2.2.4. Data availability evaluation	29
3. SEEV4-CITY RESULTS – KEY PERFORMANCE INDICATORS (KPIs)	30
3.1. Methodology	30
3.2. Baseline and Final measurements	31
3.2.1. Component data requirements.....	32
3.2.2. Baseline and Final measurements	32
3.3. KPI results conclusions	33
3.3.1. Increasing EV users in Oslo and Norway.....	33
3.3.2. CO2 Reduction or Savings.....	35
3.3.3. Energy Autonomy increase	38
3.3.4. Grid investment deferral	38
4. COST-BENEFIT ANALYSIS	44
4.1. Generic Business Model	44
4.2. Local/Regional and national subsidies and incentives	45
4.3. Base case for EV charging	47
4.4. Cost-benefit analysis	49
4.4.1. Tariff Analysis	50
4.4.2. Example of Cost/Revenue analysis based on 2017 data	59
5. LESSONS LEARNT FROM THE DIFFERENT PILOT PHASES	62
5.1. Preparation and initiation	62
5.2. Procurement	63
5.3. Implementation and installation	64





5.4. Operation..... 64

5.5. Overall for the Vulkan OP 65

6. CONCLUSIONS AND RECOMMENDATIONS 67

6.1. Issues for further consideration 67

6.2. OP site-specific recommendations for the future 67

6.3. Relevant dimensions for Upscaling and Transnational potential 68

6.3.1. Oslo 68

6.3.2. Norway nationally 69

6.3.3. Transnationally 71

REFERENCES 72

APPENDIX A 75





Glossary

Abbreviations	Terms
AI	Artificial Intelligence
API	Application Programme Interface
BEV	Battery Electric Vehicle
BESS	Battery Energy Storage System
CCGT	Combined Cycle Gas Turbine
CCS	Combined Charging System
C-rate	Battery charging/discharging rate relative to its maximum capacity (1 C refers to charging of a battery from flat to full capacity in 1 hour)
ES / ESS	Energy Service / Energy Storage System
EV	Electric Vehicle
DuOS	Distribution Use-of-System
FFR	Firm Frequency Regulation
FIT	Feed-in Tariff
ICE	Internal Combustion Engine
ICT	Information and Communication Technology
ITS	Intelligent Traffic System
KPI	Key Performance Indicator
LCOE	Levelised Cost of Energy
LV / MV	Low Voltage / Medium Voltage
MEF	Marginal Emission Factors
NPV	Net Present Value
OCGT	Open Cycle Gas Turbine
OCPP	Open Charge Point Protocol
OEM	Original Equipment Manufacturer
OP	Operational Pilot
OSCP	Open Smart Charging Protocol
PHEV	Plug-in Hybrid Electric Vehicle
PV	Photovoltaic
RDE	Real Drive Emission
RES	Renewable Energy Generation Source
SC	Smart Charging
SoC	State of Charge
TCO	Total Cost of Ownership
TCU	Total Cost of Use
USD	US dollar
V2B	Vehicle to Business
V2G / V2N	Vehicle to Grid / Vehicle to Neighbourhood
(E)V4ES	(Electric) Vehicle for Energy Service (eV4ES)





1. About the pilot

1.1. Background

The Oslo OP, which includes the EV charging and the associated support infrastructure at the Vulkan estate car parking garage, is near to the centre of Oslo on the Vulkan estate in the Grunerlokka area ¹. It is one of the largest and most advanced EV charging garages in Norway and Europe (though it also still caters for conventionally fuelled automotive vehicles). The total capacity is currently 450 parking spaces, with 102 car parking spaces with chargers reserved for EVs.

The overall Vulkan estate is a mixed-use area of a large market hall (Mathallen), shops, restaurants and cafes, two hotels, a conferencing facility (Dansens Hus), premises for concerts, dance and sport, offices and private residences, 1 km from the very city centre and on a river walk. The Vulkan estate also has a bicycle garage, with 650 spaces for bikes across the Vulkan estate, and two dedicated zones within the Vulkan car parking garage (P1 and P2) ².

The general site (not the OP boundary) characteristics of the pilot location are as follows:

- Mixed use;
- Total buildings size: approx. 29,000 m²;
- Occupancy number: 300;
- Vehicle numbers: approx. 300-400;
- Journey characteristics: Typically, mixed town/city duty cycles with short duration & distances.

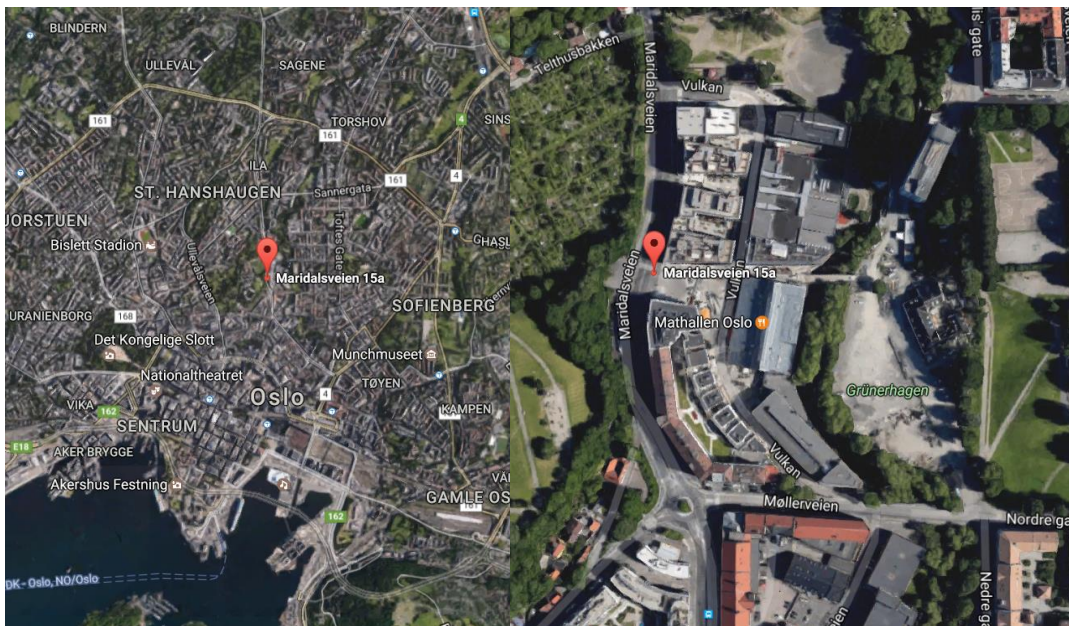

Figure 1: Google Earth image of Vulkan estate within Oslo

The building which contains the OP facility houses a small grocery store, a pub and restaurant, as well as a three-storey parking garage (the actual boundary of the OP). With 102 EV chargers, including 2 rapid chargers ³ and an additional battery energy storage system (BESS) for smart charging and peak demand shaving, this pilot (as part of the SEEV4-City project) offers a unique neighbourhood scale (vehicle to neighbourhood or V2N) case which is serving both residents, public users and commercial companies. It is an embodiment of the expected fusion between the building, energy and transport sectors (yet limited, as no overall building energy

¹ Vulkan estate is the name given to the former industrial area on the western bank of Akerselva river, north of Møllerveien road, which has been revitalised and regenerated since 2004. <https://aspelinramm.headingnorth.at/vulkanoslo.no/wp-content/uploads/20151118-Vulkanfolder-eng-02.pdf>

² <http://remakingthecity.urbact.eu/vulkan-mixed-use-development-oslo-norway--103.case>

³ The DC chargers at Vulkan are visible in Fortum's app Charge & Drive, <https://www.fortum.no/privat/lade-elbil>



demand functions are supported) ⁴. There are also several racks for bicycles and some repair equipment. Infrastructure for electric scooters and other micro-mobility devices, such as pedelecs (electric pedal assisted bicycles or even electric skateboards and Segway's has been discussed but are not yet installed (and are external to the SEEV4-City operational pilot).

With over 100 EV chargers, the Vulkan estate car park is one of the largest, in terms of EV charging capacity (EV chargers and EV parking spaces), in Oslo – with a higher capacity than the (EV only 'Akerhus' or 'Fortress' under-ground EV car parking garage (with 86 Type 2 chargers) ⁵.

During the day, Vulkan operates as a 'centre of excellence' for professional users of EVs such as electric taxis, electric freight vehicles and EVs for professional services, as well as car sharing and Car2Go services. At night, Vulkan currently offers free over-night EV charging for people living in the Vulkan (adjacent) neighbourhood (though this is meant to come in line with the on-street EV charging provision across Oslo ⁶). The actual use of the parking garage purely for parking access is separately charged (by One Park, on behalf of the building owners, the real estate company Aspelin Ramm), and for residents built into contractual agreements they have for their apartments. Besides the different day and night users, the Vulkan car parking garage is also a hub for EVs that use overnight charging at home, in combination with (semi-)quick charging during the day. This creates a flexible and cost-efficient site for the promotion of EVs. Tesla EVs can also be charged at some of the EV chargers at the Vulkan car parking garage (i.e. the two DC ones, which have both a CCS and a CHAdeMO connection point each).

Between 300 to 400 (and occasionally even more than 400) EVs are served on a daily basis according to Oslo City Council (before COVID-19 restrictions), and the turnover in terms of kWh per week has tripled since the opening of the EV charging facilities at Vulkan car parking garage in February 2017.

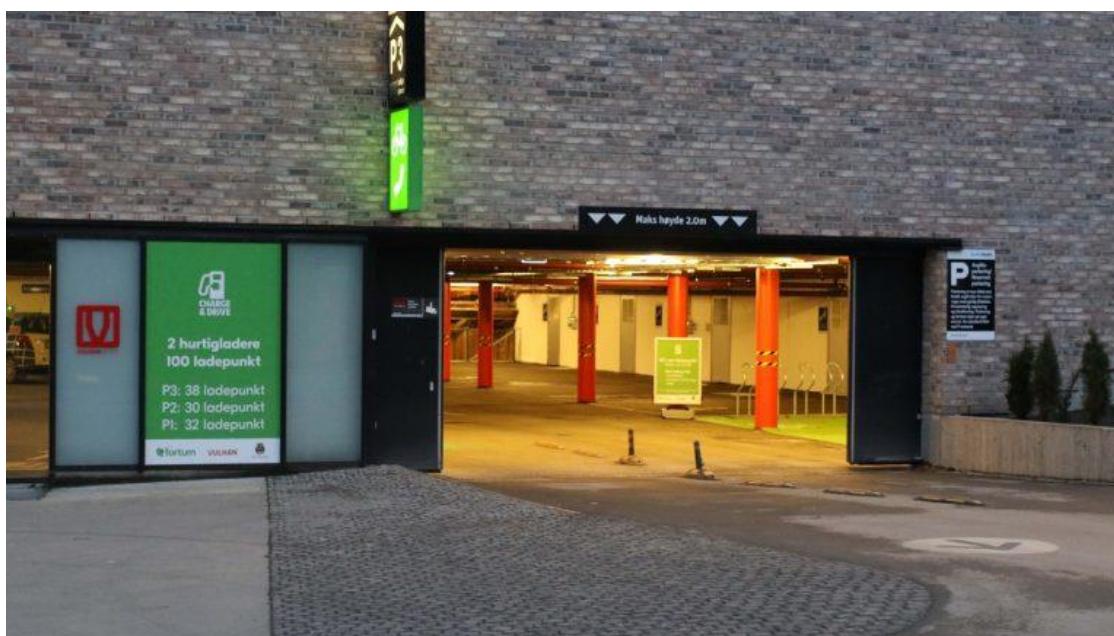

Figure 2: One of the entrances to the Vulkan car parking garage

1.1.1. Local context and energy profile

The SEEV4-City operational pilot consists of 104 EV charging plugs (owned and operated by Fortum ⁷), i.e. 100 AC standard charging connectors and 4 DC rapid-charging connectors, as well as a 50 kWh stationary battery storage (also owned and operated by Fortum, and commissioned by Ferroamp) rated at 50 kW, which supply power during periods of peak demand. This may be looked at as a low-voltage nano-grid (grid-connected).

The building which the Vulkan car parking garage is based in, has a maximum grid supply (service capacity) of 800 kW and, as a safety margin, this is usually kept below 700 kW. With the schematics and information provided by the pilot operator, the power distribution for the garage is analysed. The EV-charging infrastructure

⁴ <https://www.seev4-city.eu/projects/oslo/>

⁵ <https://elbil.no/this-is-the-world-s-biggest-charging-garage/>

⁶ <https://www.electrivedrive.com/2019/03/03/oslo-charging-electric-cars-no-longer-free-of-charge/>

⁷ Fortum (Charge & Drive) is an innovation partner of both Aspelin Ramm (the real estate company owning & developing the overall Vulkan estate) and Oslo City Council.



and the BESS are supposed to be connected to a common grid supply point via a single feeder which also supplies electricity to other loads of the car park (i.e. lighting and air conditioning).

Fortum Charge & Drive procures electricity from the central grid from an energy retailer in Oslo (through their Fortum Markets AS company), and is billed for this (under the service industry category). The Norwegian energy tariff and bill composition has changed during 2019, with now apparently lower energy (electricity) per unit costs but higher grid costs (especially peak power). In Norway (and Oslo), electricity prices now fundamentally consist of three parts: the basic power cost in Øre/kWh; a contribution towards the maintenance and development of the transmission and distribution systems known as the grid rent; and an element of taxation in Øre/kWh: VAT ('MVA') which is charged in addition on the sum of the above.

Currently, 98% of electricity in Eastern/South-Eastern Norway, including Oslo, is generated by hydro-power, with 1% generated by wind (and the remaining 1% could be anything imported) ⁸. Efficiency is 94% in the Mørkfoss-Solbergfoss hydropower station that powers much of Oslo when it opened in 1924, and the efficiency of Norwegian hydropower is now up to about 96%. The Oslo city region does not currently have a shortage of power. However, Oslo Energi and the City of Oslo have pioneered the use of an innovative revolving fund to promote energy efficiency since 1982 for the finance of energy efficiency, namely the Ekon Fund established by the City of Oslo in 1982 as a mechanism for providing and facilitating a pool of capital for retrofits. The Ekon Fund was developed by applying a small surcharge on each kilowatt-hour sold in Oslo ⁹. Solar energy is slowly on the rise in Norway, including in the Oslo region ¹⁰. There is a national solar energy cluster in Norway. There is also an Oslo Renewable Energy and Environment Cluster (for the Oslo and Akerhus regions) ¹¹. Oslo City Council is offering individual householders a subsidy of 30% of the investment for solar panel installations.

There is a national Norwegian Regulation on the requirements for Electric Vehicle Supply Equipment (EVSE) in new buildings and parking lots (Norwegian Ministry of Transport, 2016) ¹². For parking lots and parking areas of new buildings, a minimum amount of 6% has to be allocated to electric cars. The Vulkan car parking garage in Oslo very comfortably exceeds this minimum.

The overall Vulkan estate is a full-scale example of sustainable urban development. Built upon the idea of sharing localities, equipment and resources, the area is virtually self-sufficient in energy for heating and cooling. Since 2004, the area has been transformed and revitalized by Aspelin Ramm and Anthon B Nilsen property developers, based on an overall plan by LPO architects. During the development of the new Vulkan estate, the developers and architects looked at how buildings, equipment, energy and urban spaces can be shared, and thus utilized more efficiently. The Vulkan estate has its own energy plant, distributing heat and regulating temperatures amongst the buildings. Excess heat generated from refrigeration and other facilities is used to heat rooms or hot water. This redistribution of energy gives significant environmental benefits. Vulkan's energy plant is connected to Oslo's district heating system, which is used as a reserve. When extra energy is needed, it can be drawn from a series of geothermal wells reaching 300 meters below the surface.

The Vulkan estate is home to Norway's first hotel to be graded energy class A, Scandic Vulkan, as well as the first energy class A office building, Bellonahuset. The project has placed great emphasis on using eco-labelled materials with a small carbon footprint. Bellonahuset is an integrated part of Vulkan's energy supply. The building's facade collects solar energy which, via the local energy plant, is distributed to the entire area in the form of heat and hot water ¹³.

Whilst there was a plan in the inception stage of the SEEV4-City Vulkan car parking garage to add additional roof-top PV on the building which houses the car parking garage, either or both of the Board of Aspelin Ramm and/or residents influenced this in a different direction, perhaps due to fire safety concerns, towards roof-top beekeeping and urban farming for local honey and to support aphid biodiversity. According to the company that owns the Vulkan estate:

Two of the world's finest beehives are placed on the rooftop between Mathallen and Dansens Hus. The Vulkan's beehive has brought more bees to town, contributing to the effort to save these important insects. Billions of bees have disappeared in recent years. This is a big problem as bees are vital to food production through their role as pollinators. The areas around Akerselva, Telthusbakken and Gamle Aker Kirke provide abundant sources of pollen, nectar and water, used by the bees to make Vulkan honey during the summer season ¹⁴.

⁸ <https://www.electricitymap.org/zone/NO-NO1>

⁹ <http://www.iiec.org/news/298-results-center/profiles/307-oslo-norway-comprehensive-municipal-energy-efficiency-profile-79>

¹⁰ <https://www.theguardian.com/sustainable-business/2017/mar/28/oil-and-gas-norways-fossil-free-energy-renewables-oslo>

¹¹ <https://www.clustercollaboration.eu/cluster-organisations/oslo-renewable-energy-and-environment-cluster>

¹² <https://www.eafo.eu/countries/norway/1747/incentives>

¹³ <https://vulkanoslo.no/en/about-vulkan/>

¹⁴ <https://vulkanoslo.no/en/about-vulkan/>





During the day, the **Vulkan car parking garage** operates as a 'Centre of Excellence' for professional users of EVs such as e-taxis, electric freight vehicles (vans) and EVs for business & services, including two car rental and an urban shared vehicles company (car-to-go from the Norwegian railways). It allows for pre-booking of (parking and) charging time, flexible charging, battery storage, and quick charging. At night, the Vulkan parking garage currently offers free residential EV charging for people living in the neighbourhood (though this is meant to change later during 2020 to fall in line with municipal policy on on-street EV charging ¹⁵. Besides the different day and night users, Vulkan is also a hub for EVs that use overnight charging at home, in combination with standard and rapid charging during the day. This creates a flexible and cost-efficient site for the promotion of EVs.

This is also diagrammatically displayed in Figure 3, where the yellow lines represent the management responsibility, blue line represents usage of parking and charging facilities, purple line business relations (for example payments made by the EV charging infrastructure users to Fortum Charge & Drive for charging) and brown dashed line for component with an unknown relationship, though both Fortum Charge & Drive and Ferroamp (in March 2020) stated that the BESS connects with the load represented by all the EV chargers together (with currently no differentiation in the system between AC and the DC chargers in the system currently) and which does not connect (to their knowledge or responsibility, at least) with any other major load demands in the car parking garage building.

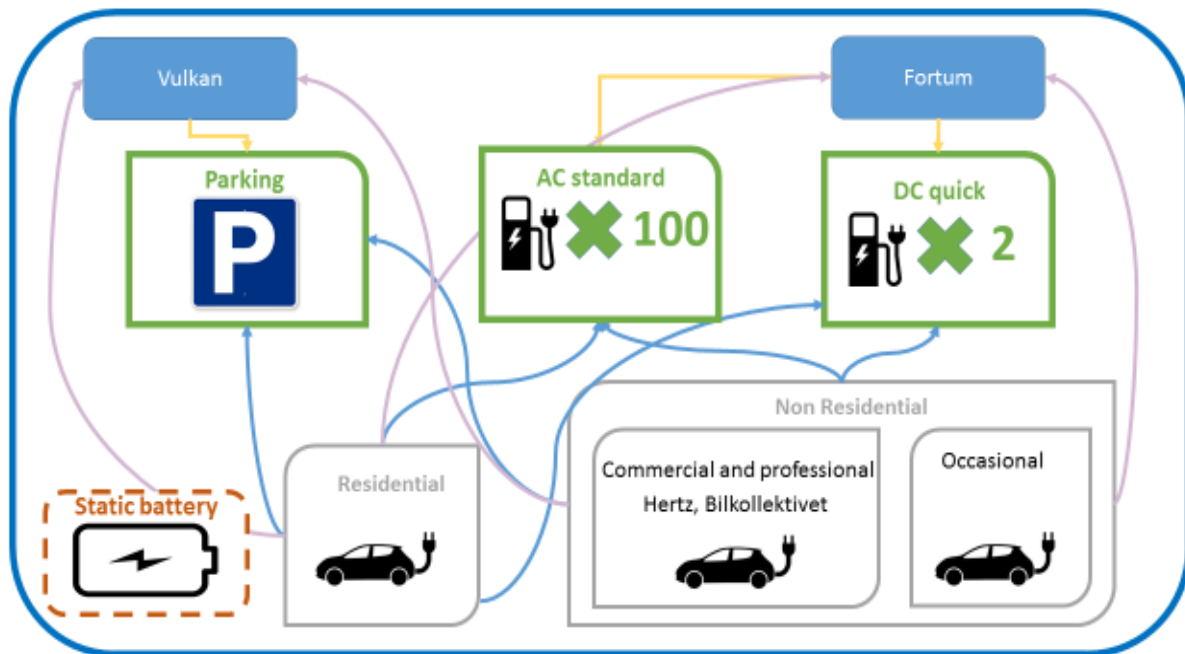

Figure 3: Overview of the Oslo operational pilot

1.1.2. Local partners

Aspelin Ramm is the real estate company that developed and owns the overall Vulkan estate (an area outside the direct city centre which was converted from an outdated industrial area into a new and modern district, which today consists of businesses within culture, education, housing, hotels, commerce and dining, as well as Oslo's first and largest food hall/court) ¹⁶.

The SEEV4-City operational pilot at the Vulkan is focussed on aspects of one residential/commercial building complex, with the car parking garage, the 104 EV charging connectors and the BESS. Fortum uses the car park as an innovation testbed for smart management of EV charging and battery storage system (developed in turn by Ferroamp) ¹⁷.

Oslo City Council (at least until June 2022) rents car parking spaces overnight for local residents, in order to avoid the investment of on-street EV charging installations, as Oslo City Council has a target since 2019 to triple its EV charging station deployment even though Oslo has deployed more EV chargers per capita than most

¹⁵ <https://www.electrive.com/2019/03/03/oslo-charging-electric-cars-no-longer-free-of-charge/>

¹⁶ <https://nordicpropertynews.com/article/2796/anthon-b-nilsen-sells-to-aspelin-ramm>

¹⁷ <https://www.fortum.com/about-charging-ev> ; <https://www.fortum.com/products-and-services/fortum-battery-solutions/recycling>





other cities in the world. Over 60% of Oslo's citizens are living in apartments or townhouses in Oslo, not in detached houses and villas with private charging opportunities. This means that not everybody can charge an EV at home, a common but serious challenge to a further electrification of transport in many urban areas and cities. The challenge is enhanced by the fact that all passenger cars sold will be zero emission by 2025¹⁸. One Park is the appointed car parking garage manager (by the building owner Aspelin Ramm).

These are the main local partners in the Oslo OP. Those companies in turn sub-contracted other companies for specific technology (e.g. BESS, algorithm, ICT, app).

Table 1: Oslo Vulkan Car Parking Garage Pilot Partners

List of partners	Ownership/control of assets
Oslo City Council	Local planning authority, and OP lead partner (and thus direct beneficiary of the match-funding from the Norwegian government under the SEEV4-City project, and investor of the other 50% of capital investment in the Operational Pilot. Also, at least until June 2022, a business partner of Aspelin Ramm in that Oslo City Council rents 100 car parking EV charging provisions overnight from them.
Aspelin Ramm	Owner of real estate, including Vulkan car parking garage (car parking management is contracted out to One Park company)
Fortum Charge & Drive	EV charging systems innovation company, EV chargers' owner as well as owner of the Ferroamp BESS, and electricity purchaser for the EV charging infrastructure. The development of the BESS was sub-contracted out by them to Ferroamp, and the development of the algorithm controlling the charging (from the grid) and discharging (to the EV chargers collectively) to another sub-contracted company.

1.1.3. Objectives and SEEV4-City KPI targets

The operational pilot aims to demonstrate the benefit of smart control of EVs and the associated ESS, as well as vehicle to neighbourhood (V2N), to reduce carbon footprint, alleviate local (low and medium voltage) power system stress, and achieve an economically feasible solution to the synergy between the building (though this is currently limited), energy and transport sectors.

The main objectives of the Oslo operational pilot are to achieve EV charging infrastructure-related load balancing for the local power network and to save on the electricity bill of the EV services provider in that way also, and at the same time to maximise the use by EVs of the car parking garage so as to promote the EV utilization more widely and to recover the cost of investment on the EV chargers and the BESS via different components of the OP business model. A return of investment for the SEEV4-City Oslo OP pilot is aimed at over a period of approximately 10 years, which is hoped to be reduced to about 8 years with the match-funding investment through the SEEV4-City project.

V2G implementation (beyond making the AC EV chargers 'V2G-ready') did not occur within SEEV4-City project duration, not least to the current Norwegian policy framework as yet on V2G [1]. The current two 50 kW DC rapid chargers (which Fortum obtained through Nissan) are apparently not yet 'V2G-ready', as they do not link to "the rest of the communications system", that is Fortum's (now Nordic-wide) Open Charge Point Protocol (OCPP) back-office (which is now upgraded to the 2.0 version).

The above-mentioned terms of smart charging (SC), V2B and V2G are collectively referred to here (and the SEEV4-City project overall) as EV for energy service (EV4ES). A successful business model is essential for the wide implementation of this EV4ES concept in real-life applications, and would therefore help to promote the EV utilization and achieve the ambition of City of Oslo to have more than 200,000 electric vehicles on its streets by 2020¹⁹.

Different from most other SEEV4-City pilots, the Vulkan car parking pilot has no integration of locally generated renewable energy in the form of PV (see above). Norwegian power demand is supplied 98% from clean energy – i.e. hydropower [2]. The Energy Autonomy KPI therefore cannot be evaluated for this pilot. The SEEV4-City project uses other two key performance indicators (KPIs), namely CO₂ emission savings and grid investment deferral, to measure the environmental and economic benefits achieved by providing EV4ES. The electric vehicles analysed in this pilot, either battery electric vehicle (BEV) or plug-in hybrid electric vehicle (PHEV), are referred to as 'EV(s)' in the rest of this report. It is also worth noting that the Vulkan parking garage does not only provide parking facility to BEVs and PHEVs, but also to (and currently at least in the provision of spaces,

¹⁸ <https://carbonneutralcities.org/building-a-ubiquitous-electric-vehicle-charging-infrastructure/>

¹⁹ <https://www.seev4-city.eu/projects/oslo/>





and perhaps also utilization) internal combustion engine (ICE)-based vehicles (which are not within the scope of the SEEV4-City project or this pilot).

Table 2: Oslo Vulkan car parking garage pilot’s SEEV4-City KPIs targets

Oslo Vulkan OP – KPIs	
KPI	Target
A CO ₂ emission savings	90-120 tonnes annually
Sub-KPI: ZE km increase factor	Increase factor 1.5
B Energy autonomy increase	Not applicable
C Grid investment savings/deferral (by peak demand reduction)	20% peak reduction

1.1.4. System design

The Oslo operational pilot represents a unique setting of integration of EV charging infrastructure energy, stationary grid connected electricity, electric transport and EV parking. The system used to develop the (Vehicle4) Energy Service (V4ES), is composed of several building blocks as visualised in Figure 4:

- The local voltage network, distributing the energy to the charging stations.
- The vehicles, using the charging stations to charge their batteries.
- BESS system for battery storage
- AC chargers ('V2G ready', not yet used for this purpose) and DC chargers

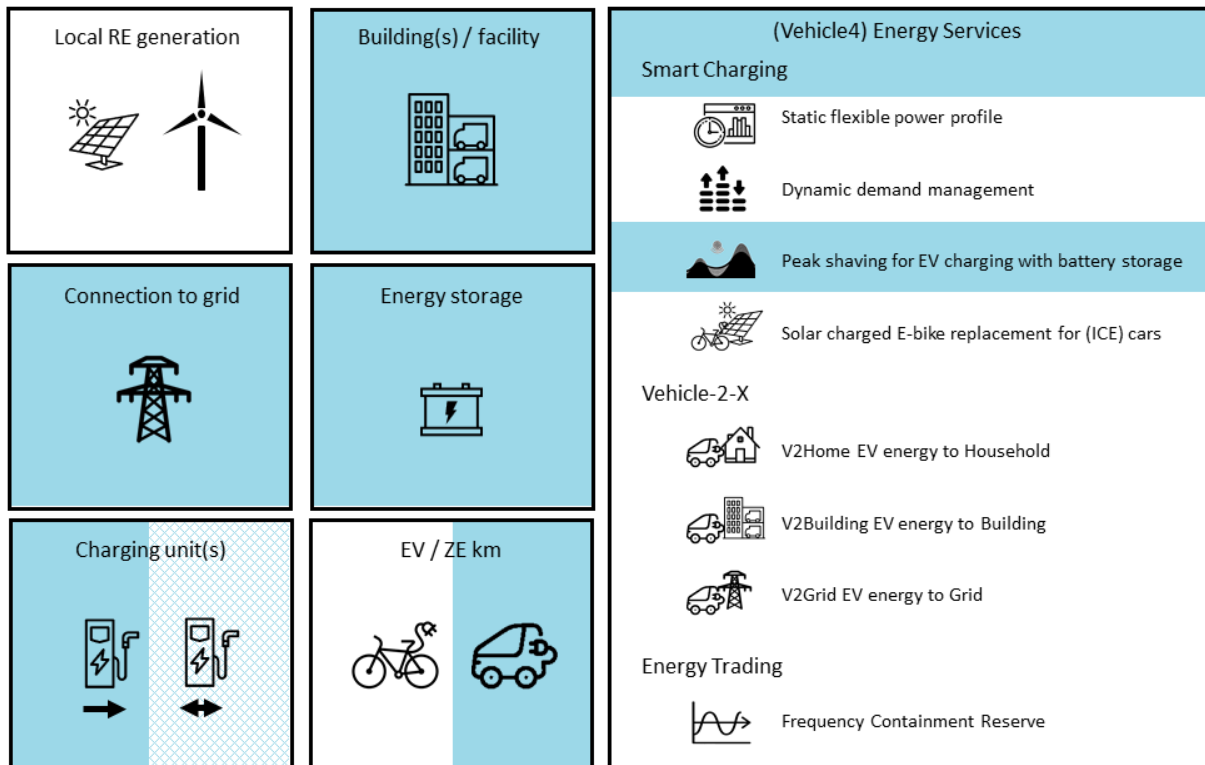

Figure 4: Pilot V4ES solution(s) building blocks

Following on from the business structure as depicted in section 2.1.2, the Oslo operational pilot setting as well as the timelines of the events will be explicitly presented.

The Vulkan parking garage serves both residential and commercial EVs, which can choose to charge from the 100 AC standard charging connectors and the 4 DC rapid charging connectors (for those only one EV can charge at any one time, as the internal architecture does not allow for simultaneous CHAdeMO and CCS charging).

Apparently, there is currently no dynamic smart charging of EVs in place at the Vulkan car parking garage. Since there are currently also no dynamic electricity tariffs/prices in place in Norway or Oslo, this is not





surprising. However, there is some intervention during peak power demand times from the installed stationary battery (BESS). The BESS is recharged from the grid at demand trough. As such, smart charging is implemented by Fortum Charge & Drive. On the other hand, smart parking management is handled by One Park to maximise the utilization of the car park (but with no information on this supplied to the SEEV4-City project or for analysis in this report).

Table 3: Oslo Vulkan Car Parking Garage Pilot Overall Specifications

Component	Description
PV system	Pilot setup changed at the implementation phase, therefore no local PV
EVs	Owned by residents, professional service companies, car rental companies (both BEV and PHEVs) and NSB car-to-go (Renault Zoe)
EV Chargers	50 AC chargers/units with two connection points each– flexible since December 2017 2 DC fast chargers
Stationary Battery Storage system with inverter for phase-balancing	50.4 kW Ferroamp Li-ion battery, and 50 kW inverter

The Vulkan estate car parking garage of the Oslo OP has 50 AC chargers (with two connectors each) and also two 50 kW DC chargers. The 100 AC charging connectors can be used in a charging speed range from 3.7 to 22 kW/h, depending on the EV on-board controller. The V2X units require a software modification, which has been done as part of the project for the AC chargers (which are now 'V2G ready') in order to interact with V2X-enabled EVs²⁰. Users are able to choose what speed to charge with via a mobile application. The AC charger users can now charge at 3.7 kW, 7.2 kW, 11 kW and 22 kW, and the installed software allocates the highest charging speed that an EV can handle in this regard if there are no peak power issues. According to Fortum Charge & Drive, it turned out to be too complex for the users to deal with a price model of differentiated fees for the different AC charging speeds.

Fortum Charge & Drive tested differential charging fees per AC charging speed, which were discarded after not picking up any (favourable) customer response to this, and they simplified this into one single fee for AC charging. This pricing model, according to Fortum Charge & Drive, seems to be working better for the EV drivers. The flexible choice is still in operation and seems to be working for Aspelin Ramm, Fortum Charge & Drive and the users. The volume of EV charging has been increasing significantly (prior to COVID-19), so the Return-on-Investment (ROI) for Fortum Charge & Drive and Aspelin Ramm is improving.

A block diagram of the electrical power supply to the EV chargers and the car garage is shown in Figure 5. This diagram is derived from a set of original schematics to illustrate the whole system which was intended to be built. One of the original schematics is enclosed in the appendix. As shown in the block diagram in Figure 5, the nexus of the distribution network is a main substation for the EV charging facility (labelled 435.02.01 in the original schematics) that is supplied from the grid. The 2 DC fast chargers and the 50 AC chargers that are installed throughout the three-storey car parking garage and the BESS are all fed from this nexus. There are 16 AC chargers on the first floor and 15 AC chargers on the second floor. On the third floor, there are 19 AC chargers and 2 DC fast chargers. It is worth noting that there are also loads which are unknown from the original schematics that are fed from the nexus as well. The so-called "to other loads in garage" are supposed to be the lighting and/or air conditioning and perhaps also heating, according to the information provided by the pilot.

The schematic of the Oslo Pilot is shown in Figure 6, where a 1.5 MA transformer is used to feed the whole EV charging and BESS from the medium voltage grid. Based on the information provided by the OP, there are no additional 'significant' loads except the EV charging stations that are connected to the local grid fed by the 1.5 MVA transformer. The local grid is a 400 V distribution network with a 1,250 A feeder to the car parking garage. Currently, according to the Ferroamp portal and an interview with Ferroamp engineer, less than 70% of this 1,250 A feeder capacity is currently used. The 7 battery modules (of which two are currently faulty since the

²⁰ A report by Cenex UK [3] maintains that 'AC V2G is generally seen as a theoretical concept as it requires additional hardware to be installed in the vehicle which many car manufacturers believe will lead to lower efficiencies and higher costs. However, while there are no commercial AC V2G warranted vehicles currently in the UK market, Renault (with the Zoe) and BYD (with the e6) have been trialling AC V2G since 2015 and Hyundai Mobis announced in 2017 that it had developed a two-way on-board charger (OBC) for future electric and plug-in hybrid vehicles', see: (<https://www.cenex.co.uk/app/uploads/2019/10/V2G-Market-Study-FINAL-LCV-Edition-with-QR-Code.pdf>). There is also, for instance, an AC-based V2G trial in Utrecht with modified Renault Zoe EVs, see: <https://easyelectriclife.groupe.renault.com/en/outlook/energy/renault-tests-its-bi-directional-charging-system-in-utrecht/>. The Cenex UK study refers to Norway's market readiness in terms of Demand Side Response (DSR) as 'partially opening'. The recent journal article by Kester et al. (2018) [1] comes to a similar conclusion (<http://sro.sussex.ac.uk/id/eprint/73770/3/1-s2.0-S0301421518300995-main.pdf>).





end of 2019) of the Ferroamp stationary battery (50.4 kWh) are connected through a DC-bus to a 760 V DC nanogrid. The EnergyHub in the diagram is the (single) bi-directional inverter, which can both supply power to the EV chargers and take it from the grid as well. The EnergyHub also performs the important phase balancing – which is uneven loading of the three phases – at the Vulkan car parking EV charging installation.

Two data acquisition and recording systems, namely the EV charger information systems (first locally by Fortum Charge & Drive, and then migrated to Fortum Charge & Drive’s Nordic back-office and periodically provided to UNN by Excel files) and the Ferroamp live online monitoring system (with UNN access under a Non-Disclosure Agreement with Fortum Charge & Drive), are adopted to record the measurements of the electricity distribution networks.

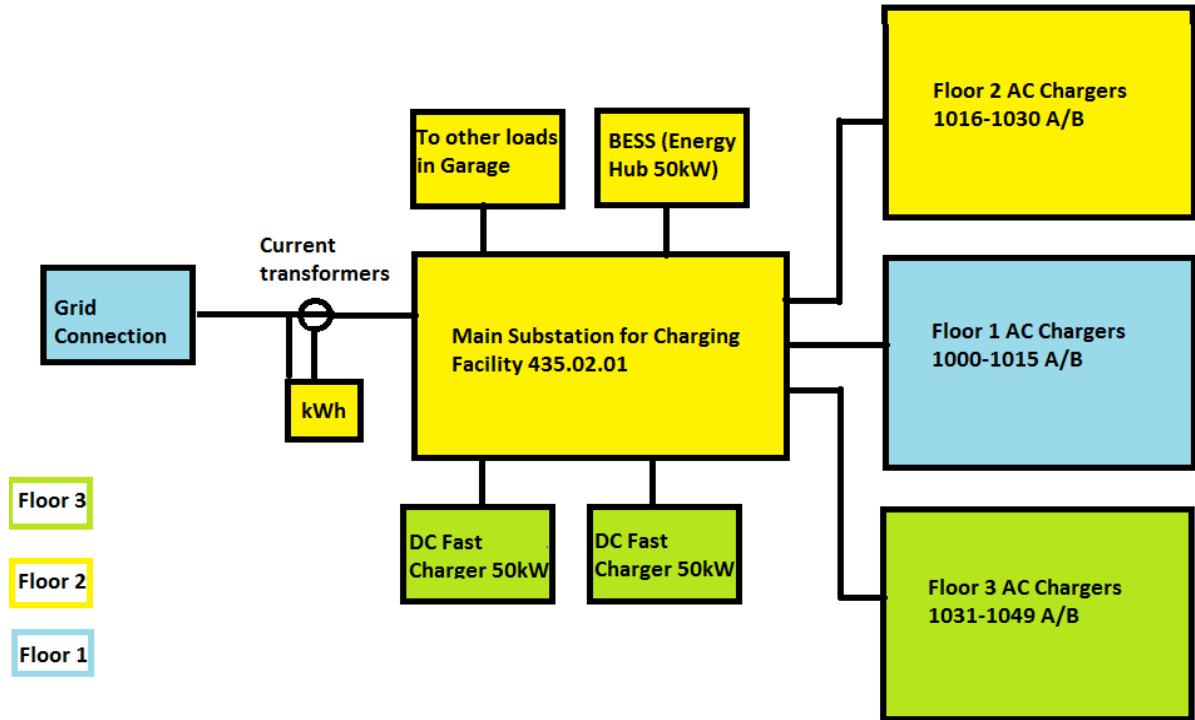

Figure 5: Block diagram of the power supply system to the EV chargers, SESS and the garage.

The measurement points of the data acquisition system for the pilot are shown in Figure 6, where the blue M with white background indicates the assumed measurement points of energy consumed for EV charging at every individual charging station. This is an event-trigger recording system and records the connection starting time, connection end time, and as well as the electricity consumed by each EV charging activity. It is worth noting that the schematic diagram of the pilot operator shown in Figure 6 has been revised according to the in-depth analysis of the detailed schematics provided by the pilot operator. For the original schematics, please see the Appendix where a PV system is shown but this has never been deployed with regard to the system actually installed in this operational pilot.



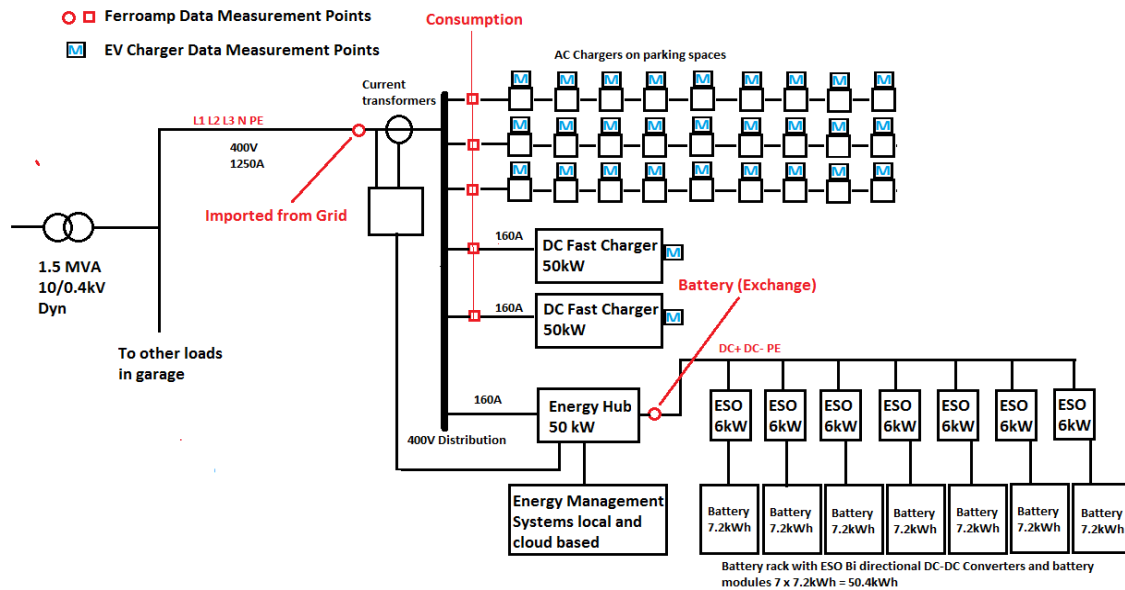

Figure 6: Pilot schematic – system design components

The energy management (Ferroamp) system shown in Figure 6 is a cloud based and time-triggered data-recording system that measures the power and energy “imported from grid”, “battery (exchange)” and “consumption (of all EV chargers)”. The measurement points of the Ferroamp system are inferred from the information provided by Fortum Charge & Drive, as well as from Ferroamp as their supplier, and are labelled in Figure 6 with a red circle or rectangle.

It is stated by the pilot field operator that the “consumption” data of the Ferroamp system only measures the consumption of the EV chargers. However, the UNN data analysis shows that the value of energy consumption derived from the EV charger system (at least going by those Excel files that were provided) and the value of the “consumption” data in the Ferroamp system are mismatched, although other Excel files forwarded with energy/power “consumption” (unspecified) match the “consumption” in the Ferroamp system neatly with only a marginal difference.

It is still unknown if the very significant mis-match between the EV chargers Excel sheet-based information (much lower, by a factor of nearly 3) and both the other Excel datasets on “consumption” and the live Ferroamp systems’ “consumption” is caused either by the incomplete data records of the EV charger system, or perhaps by both the “consumption” data of the second Excel files simply labelled “consumption” and likewise the “consumption” category in the Ferroamp system including both the consumption of EV chargers and other loads (e.g. car parking garage lighting and other features to explain the large difference).

There are three (types of) main devices operated in the distribution network, namely, the EV Chargers consisting of both AC and DC faster chargers, the BESS, and an Energy Management System. It is worth noting that no PV system is installed/deployed with regard to this operational pilot.

1. EV Charging Stations

There are both AC charging stations/units and DC charging stations/units, which are supplied from the main 1,250 A feeder. The 50 kW DC fast chargers are connected to the 3-phase 400 V distribution network. The AC charging stations at the car parking garage are organized in three lines associated with the power supply of three phases. The charging power at the AC outlets may vary from 3.2 kW to 22 kW, depending on the connected EV, and the total load on the AC and DC chargers collectively. The distribution of energy between the chargers are calculated by an algorithm.

Without more details of the algorithm (which neither Fortum Charge & Drive nor Ferroamp have in any detail or resolution), it is unknown how the charging speed is decided to distribute charging power among the EV charging stations – other than that there is phase balancing implemented (as quite a few of the charging EVs are single-phase, and this can cause significant power imbalances between the three phases overall, depending where they are connected).

Other than the BESS, apparently there is no other system’s function that is controlling the chargers apart from the charger controller to ensure each EV is getting the power it requests. The BESS is used to reduce the power demand in addition to provide phase balancing.





2. Energy management system

This is a cloud-based energy management system, called Ferroamp, but with no active or dynamic involvement of EV users/owners or the building owners in the operation of the BESS. Currently, the technical set-up is that an EV, through the EV charger, will obtain the highest charging speed the EV charge controller requests. The Ferroamp system records the energy exchange between the BESS, the grid and the EV chargers. This is denoted as EnergyHub in the Ferroamp schematic. The bi-directional inverter, can take energy from the AC side to charge the stationary battery and can also take energy from the stationary battery to support the AC chargers side. The BESS also performs the function of phase balancing.

The energy management system was launched in February 2017, which records energy imported from (main) grid, consumption (by the car park) and the energy exchange with the BESS.

Peak shaving and phase balancing of the EV charging infrastructure are the main functions of the BESS. The peak shaving is based on real time measurements of EV charging infrastructure power consumption. If total import power from the grid exceeds a pre-set threshold, the stationary battery will start to discharge to try to keep imported power from the grid below the threshold. If import power from the grid is below the threshold, the stationary battery will charge from the grid.

In addition to the peak shaving, the inverter is also controlled to provide a phase balancing function. This function is executed by measuring the total grid 3-phase currents and transferring energy between the phases to balance and thus minimize the individual grid currents. The maximum current balancing of the present inverter is about 40 A. The phase balancing function does not need to cycle the stationary battery to operate, and is essentially independent from the battery; however, some of the inverter capacity is used when the battery is discharged and battery operation is then prioritized in terms of the inverter function.

3. Battery energy storage system (BESS)

The BESS is a 50.4 kWh stationary battery, consisting of 7 battery modules of 7.2 kWh each operating as a 760 V DC nanogrid. The BESS has a 50 kW inverter. The DC nanogrid exchange energies with the 400 V AC distribution network via an inverter, referred to as EnergyHub in Figure 6.

The energy storage solution will shave the peak before this, but the amount of energy stored is limited (50 kWh); the BESS has two pre-set thresholds: when the garage EV charging demand is over a pre-set threshold, the stationary battery discharges to shave the peak demand. If the EV charging demand is less than a pre-set threshold, the stationary battery starts charging from the grid.

At the beginning, this was set to as follows: if the total consumption of both AC and DC charging together exceed 200 kW, then the BESS discharges to support the EV charging infrastructure, and if the EV charging infrastructure consumption drops below 150 kW the BESS would charge from the grid.

Since early March 2020, the BESS has been operated in the following thresholds:

- Discharging threshold 270 kW: discharging when the car park power consumption is over 270 kW;
- Charging threshold 250 kW: charging when the car park power consumption is lower than 250 kW.

There are different layers of defence against the power peaks associated with EC charging:

- Typically, the way Ferroamp sees their system is that “there is a first layer of defence which is the phase balancing. A lot of the EVs in Oslo are still single-phase chargers, and they end up on different phase connectors, depending on which parking spot they occupy. At the Vulkan car parking garage one does therefore see a very large phase unbalance. And this means that one can have perhaps 500 A in one phase connection and 300 A in another. This is also limiting the capacity that one can take from the grid. We have a first layer of defence to balance the phase consumption. This is something that the inverter does, and there is no need for the stationary battery for that. So, it is sort of absorbing: as an example, if one 300 A on two phase connectors and 500 A on the third one, the inverter takes energy from the two phase-connectors with 300 A and injects it in to the one with 500 A. Therefore, this is dynamically balancing and results in some more headroom for additional EV chargers;
- The second line of defence is the battery. Even with the dynamic phase balancing system there is a current limit. Then the battery is activated to provide energy to the chargers;
- And then, as a third line of defence the EV’s charging capacity is reduced. A third line of defence, such as an energy management system, needs to tell an EV charger/ EV that it cannot charge at 10 kW etc. and that this speed has to be reduced. Currently this is not technically provided, and not performed at the Vulkan car parking, as the EV charging installation is not yet at its full cable capacity in this building. There is no need to do this, at least from that perspective.” (source: interview on 26th of March 2020 with Björn Jernström, Ferroamp engineer).





This car parking garage contains 104 charging connectors in total, i.e. 50 AC standard chargers (Type 2) and 2 DC fast chargers, each one with two charging connectors. The technical parameters and configuration of the charging stations are listed in Table 4. For the EV charging stations, an application programme interfaces (API) is provided for the EV chargers to decide when and how much energy will be charged, in conjunction with the on-board vehicle electronics.

Table 4: Technical parameter setting for the EV charging infrastructures

Variable	Value	Unit
AC charger speeds (from Dec 2017)	3.7, 7.4, 11, or 22	kW
DC charger charging rate	50 (fixed)	kW

Since December 2017, the 50 AC chargers have been enabled for smart charging with flexible charging rates at namely 3.7 kW, 7.4 kW, 11 kW, or 22 kW. The two DC fast chargers can both provide 50 kW and have two plugs each, one CHAdeMO and one CCS (400 V/ 125 A). This is in line with other fast chargers in and around Oslo (except for a few 44 kW chargers).

As mentioned in the background of the Oslo pilot, free parking is available (for local residents) from 5 p.m. to 9 a.m. the next morning. The price for using this car parking garage for the rest of the day is 15 NOK per commenced 30 minutes with a max of 270 NOK per single parking event within 24 hours ²¹.

The cost for DC fast charging has been fixed at 2.5 NOK/min from the beginning of the car park operation. EV charging via AC chargers was free since the beginning of the pilot between 5 p.m. – 9 a.m. weekdays and 5 p.m. – 11 a.m. on the weekend. An AC charging price during the day, which is charging rate dependent, was introduced on 23rd October 2017 – as detailed in Table 5. This was replaced (in December 2018) by a uniform daytime price for AC charging of 2 NOK/min, regardless of the charging speeds.

Table 5: Economic parameter setting for the OP

Variable	Value	Unit
AC charger rates (from Dec 2017)	3.7 kW, 7.4 kW, 11 kW, or 22 kW	kW
DC charger rates	50 kW	kW
AC charging cost	<ul style="list-style-type: none"> • Free between 5 p.m. - 9 a.m. on weekdays and 5 p.m. - 11 a.m. on weekends • Daytime charge from 23rd Oct 2017: <ul style="list-style-type: none"> ○ 22 kW @2.75 NOK/kWh ○ 11 kW @2.5 NOK/kWh ○ 7.4 kW @2.25 NOK/kWh ○ 3.6 kW @2.0 NOK/kWh • Daytime charge since Dec. 2018, and currently still in place: <ul style="list-style-type: none"> ○ 3.7, 7.4, 11, and 22 kW @2 NOK/kWh 	NOK/kWh
DC charging cost	2.5 (3.1 from early 2020)	NOK/min
Parking cost	<ul style="list-style-type: none"> • Free for 5 p.m. - 9 a.m. • Otherwise 15 NOK per commenced 30 minutes up to 270 NOK per coherent parking period within 24 hours 	
Stationary battery size	50.4	kWh
Stationary battery charging rate	Up to 50	kW
Electricity tariff price	0.8	NOK/kWh
Building load limit	800	kW
AC standard charger cost	65,000	NOK
DC fast charger cost	1,500,000	NOK

The timelines of the pilot evolution are summarised in Table 6. This is based on the information provided by the pilot and those collected from the related websites. It could be seen from this table that the smart charging functionality for AC chargers is enabled from December 2017. This is to achieve part of the load balancing

²¹ As found on: <https://onepark.no/parkering/oslo/vulkan-p-hus/> (Norwegian translated to English)





target, i.e. to control the building demand within the safety margin of 700 kW out of the 800 kW electrical limit for the Vulkan car parking garage. The associated protocol has also been upgraded around May/June 2018 from OCPP 1.6 to OCPP 2.0.

Table 6: Timeline of events for Oslo Vulkan car parking garage pilot

Jan 2017	Start of data collection
Feb 2017	Activation of Ferroamp database
Oct-Nov 2017	Introduction of payment for AC day-time charging
Nov 2017	End of first data set
Dec 2017	<ul style="list-style-type: none"> • In Dec 2017, the standard chargers were replaced with flexible-speed ones; • all AC and DC chargers are (collectively) involved with load balancing through the BESS; • all AC chargers are enabled for Smart Charging.
May 2018	<ul style="list-style-type: none"> • Fortum migrated to Nordic operations to a brand-new back office system, with new native apps to end users; suspension of charging fees during this migration; • At the end of May 2018, Fortum Charge & Drive rolled out a new AC day-time charging (by different speeds) pricing structure.
End of June / October 2018	<ul style="list-style-type: none"> • Monitoring during new AC differentiated pricing structure; • At the end of the trial period (June/October 2018), Fortum decides to remove the speed-differentiated AC charging pricing structure, and puts in place one single fee for AC day-time charging; • Now users cannot select the charging speed & the highest charging speed is used regardless how a user chooses to start charging (RFID, SMS or App).
Potential events and updates	<ul style="list-style-type: none"> • According to Fortum Charge & Drive, exact future new pricing – if revised – is likely to be combination of user, load and time specific pricing; • All AC outlets are 'V2G ready' (from December 2018 onwards); but the DC chargers are not since they cannot currently communicate with the Fortum Charge & Drive Nordic back-office; • More V2G capable vehicles are needed in Oslo – EV -based software to enable V2G charging is needed; • Perhaps super quick chargers to be introduced (100 kW or above) by either Fortum Charge & Drive or Aspelin Ramm in the future, but Oslo City Council left that investment decision in the end only to them and not to be co-financed by the SEEV4-City project or OCC.





2. Data collection and processing

2.1. Assumptions and research questions

The following key assumptions are made in conducting the evaluation of Oslo pilot, in line with the SEEV4-City project methodology. These assumptions are held throughout the pilot analysis and are arranged in the order when they first get mentioned in this report:

- The methodology for energy autonomy is defined in this report as part of the KPIs, but the associated evaluation is not implemented here due to the absence of the PV installation.
- Battery degradation is not considered in the Oslo OP implementation for the stationary battery. The EV battery degradation is not within the boundary of the SEEV4-City project.
- The stakeholders considered within the boundaries of the Oslo pilot include Aspelin Ramm (the real estate company that developed and owns the overall Vulkan estate), Fortum Charge & Drive (which equipped the Vulkan car parking garage with 52 chargers or 104 EV charging outlets and used the car park as an innovation test bed for smart management of EV charging), and One Park (the car park manager).
- The overall aim of the pilot is to achieve load balancing for the local power network and thereby also save on electricity costs for the EV charging service company, and at the same time maximise the utilization of the car park, so as to promote the EV utilization and to recover the cost of investment on EV chargers and the BESS.
- The BESS supplies both the AC and the DC quick chargers and during periods of peak power demand by them.
- Charging duration and connection/parking duration: the data “duration” in Dataset 1 is the parking time (also referred to as connection time), represent the duration how long an EV is connected to a charging station. This is the minimum time an EV parks at the parking space provided with an EV charger. During this period, the EV may not always be charging, for example, when the battery has been fully charged. Then the actual charging time is equal or less than the connection/parking duration.
- The consumption data in Dataset 3 (i.e. the Ferroamp database) is now assumed to cover the EV charging profile and stationary battery charging only.

2.2. Data processing

As detailed in Table 7, three type of datasets were made available regarding the power/energy flow for each of the energy components in the Oslo pilot, directly or indirectly from the associated OP stakeholders.

Table 7: Data procurement information for the OP

Datasets	Providers	Time reached UNN	Data period
Dataset 1: EV chargers in Excel file	Fortum Charge & Drive [indirectly, through the then SEEV4-City project coordinator]	November 2017	01/01/2017 – 16/11/2017
		Jan 2020	June/2018 – Jan/2020 *
Dataset 2: Load profile in Excel file [without any specification or clarification as to what constitutes this load]	Isak Oksvold from Aspelin Ramm Eiendom AS	November 2018	12/03/2017 - 21/06/2018
Dataset 3 : Ferroamp (online database)	Snorre Sletvold from Fortum Charge & Drive	November 2018	20/02/2017 – present **
Note: * Data from June 2018 to Dec 2018 is invalid due to very low number of charging sessions. ** Data from 13/04/2018 to 07/06/2018 is missing.			

2.2.1. Dataset 1 – EV chargers’ dataset

The EV chargers’ dataset recorded the start charging time, energy charged and duration of each charging session, for both the AC and DC chargers. Two data sheets, titled ‘DC’ and ‘AC’, are available in the excel data file provided by Fortum Charge & Drive. The charging duration in the ‘AC’ sheet showed the same value for all the charging sessions per charging device, which is probably due to erroneous readings. An example is shown





in Figure 7. This was later confirmed in a telco with the Fortum Charge & Drive IT back-office (Oscar Ekman) as unlikely to be correct. The data in the 'AC' sheet was therefore excluded from the analysis. Charging records for both the AC and DC chargers with correct charging duration were found in the 'DC' sheet, where the AC charging events can be matched up with those from the 'AC' sheet. The two charging outlets for each of these AC 50 chargers can be identified by the property of 'Resource' in the 'AC' sheet, and these constitute the 100 AC chargers as per the pilot setting. The following analyses were therefore carried out based on the currently available data from the 'DC' sheet, covering 01/01/2017 - 16/11/2017.

	A	B	C	D	E	
1	StartTime	Device	DeviceType	Time	Volume	Unit
11	2017-11-16 22:16:13	Vulkan P3 983	Tritium Veefil 2 Connectors	44	22.28	kwh
14	2017-11-16 22:20:50	Vulkan P3 984	Tritium Veefil 2 Connectors	5	2.15	kwh
16	2017-11-16 22:08:46	Vulkan P3 984	Tritium Veefil 2 Connectors	10	6.26	kwh
17	2017-11-16 21:17:44	Vulkan P3 984	Tritium Veefil 2 Connectors	22	12.09	kwh
21	2017-11-16 19:32:58	Vulkan P3 984	Tritium Veefil 2 Connectors	65	43.86	kwh
22	2017-11-16 20:15:30	Vulkan P3 983	Tritium Veefil 2 Connectors	13	9.31	kwh
30	2017-11-16 17:41:03	Vulkan P3 984	Tritium Veefil 2 Connectors	23	10.29	kwh
32	2017-11-16 17:40:15	Vulkan P3 984	Tritium Veefil 2 Connectors	1	0	kwh
33	2017-11-16 17:13:37	Vulkan P3 983	Tritium Veefil 2 Connectors	20	8.96	kwh
34	2017-11-16 16:41:24	Vulkan P3 984	Tritium Veefil 2 Connectors	28	6.14	kwh

Figure 7: An example of data recording error in Dataset 1 (some outlier data is also presented in the data set, see the highlighted numbers in the red colour)

Number of charging sessions per charging station

First, the number of charging sessions for each chargers, AC and DC, are shown in Figure 8 where the utilization of the two DC chargers outnumbered that for the AC chargers. Another observation from Figure 8 is that the number of charging sessions are not evenly distributed between the AC chargers.

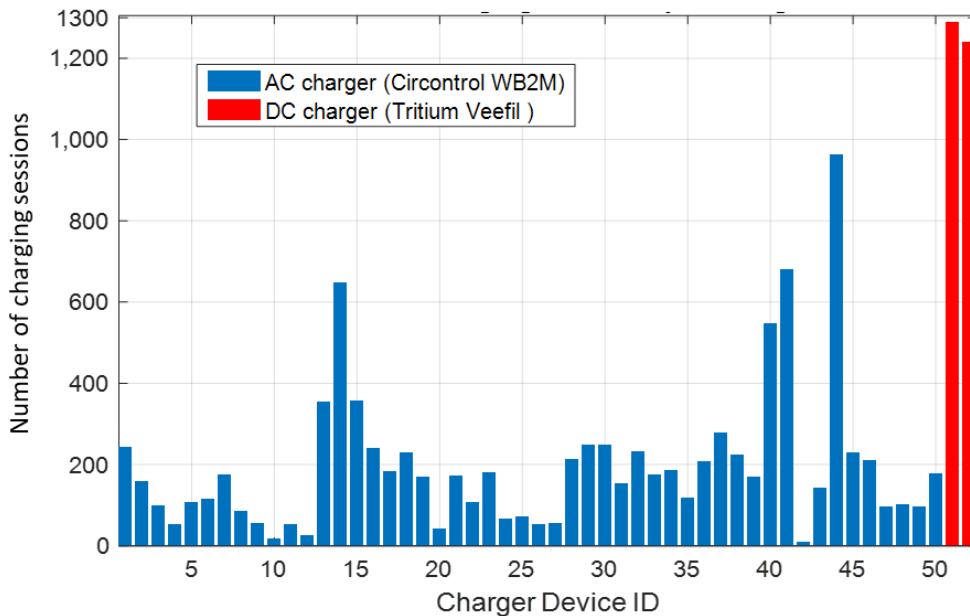

Figure 8: Number of charging session per charger

The statistics on the EV connection time and number of charging sessions can be found in Table 8.





Table 8: Statistics on EV connection duration

	100 standard AC Type 2 chargers	2 quick DC chargers	Total
Charging sessions – Total	7,085	3,007	10,092
Charging sessions – Average per day	9.426	22.210	31.636
kWh charged – Total	93,450.89	27,188.28	120,639.2
kWh charged – Average per session	13.19	9.04	11.95
kWh charged – Average per day	292.95	85.23	378.18
Minutes spent charging – Total	1,289,470	64,520	1,353,990
Minutes spent charging – Average per session	20	21.46	20.73
Minutes spent charging – Average per day	4,042	202	4244

EV connection and charging durations

As discussed in the assumption section, the data “duration” in Dataset 1 represents how long an EV is connected to an EV charging station. That may or may not be equal to how long the EV parks at the parking space, but obviously the parking time would be at least the length of the connection time. However, depending on the battery status (or the charging policy), the connection time is not always the same as the charging time. During the period of parking time, the EV may not always be in charging operation, for example when the battery has been fully charged. Then the actual charging time is equal or less than the connection duration. However, the connection time is a good index for the charging time, in particular, when the connection duration is relatively short and the EV leaves without being fully charged.

The histogram of the EV connection time, for both AC and DC chargers, is illustrated in Figure 9. As can be seen, the frequency of connection duration decreased exponentially over time and short length charging (within half an hour) was the shown as the prevailing charging behaviour. Comparing the connection duration of year 2017 (Figure 9, on the left) and that of year 2019 (Figure 9, on the right), it can be found that the pattern are similar, but the number of sessions in the year 2019 is much higher than that in the year 2017.

An in-depth analysis suggests that the highest frequency of charging sessions is in the range about 20 minutes. Figure 9 only depicts the charging session shorter than 1441 minutes (24 hours), and the full data sets also shows that some charging session are longer than 24 hours. A few ones are longer than 4 days. These extremely long charging sessions only make up a small portion and represent rare scenarios; this is therefore regarded as outlier data. This outlier data is not further considered in this analysis report.

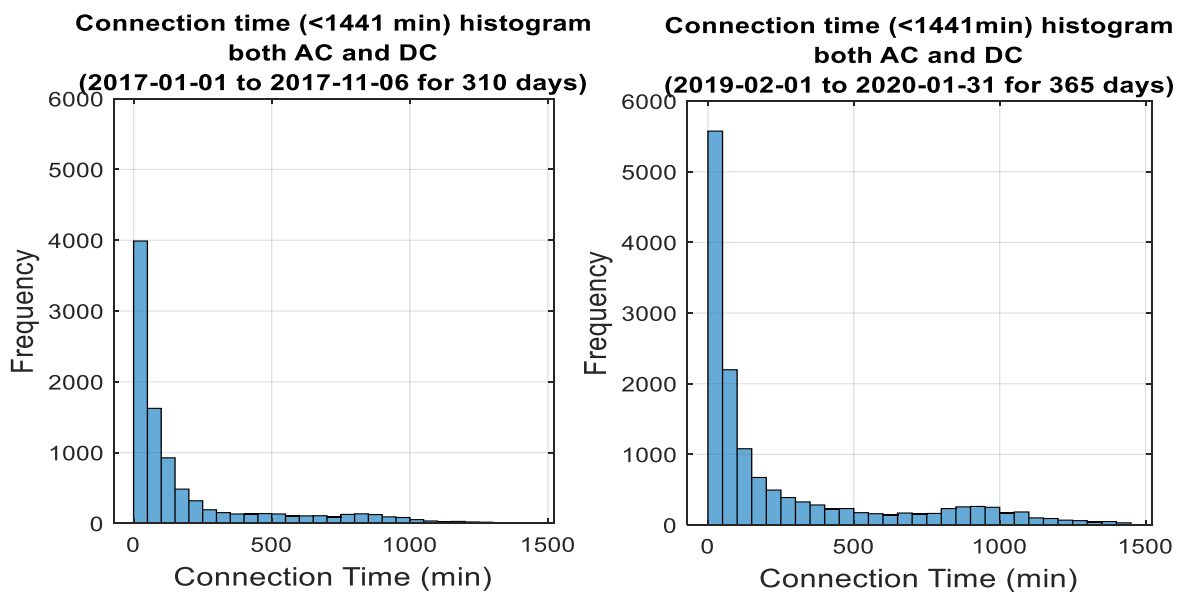

Figure 9: Histogram of connection time duration (both AC and DC) during the period of 01 January 2017 to 06 November 2017 (on the left hand side) and the period of 01 February 2019 to 31 January 2019 (on the right)





EV charging energy and connection time

EV charging events for a period of one year (01/02/2019 to 31/01/2020) are presented in Figure 10, which shows how much electricity was consumed for each charging event against the connection time. As can be seen, the charging events are scattered, with a dense area in the period of relatively short connection times. The dense area means there are more charging sessions falling in this (energy-time) region; for example, the area with charging duration less than the 200 minutes. The red colour represents the DC charging sessions and it can be seen that DC charging duration is much shorter and consumes more electricity than AC charging (blue colour). This reflects the definitional feature of a DC fast charger.

It is also interesting to observe that there is an area from about 800 minutes (about 13 hours) to 1,000 minutes (about 16 hours) and energy from 5 kWh to 20 kWh, where the charging session is dense. This may represent the residential users returning home after work in the evening (e.g. 6 p.m.) and departing for work in the following morning (e.g. at 7 a.m.).

It is worth noting that the parking time may differ from the charging time. As discussed earlier, the actual charging time is equal or less than the connection time. This explains the dense area of 800 minutes to 1,000 minutes, and 5 kWh to 20 kWh.

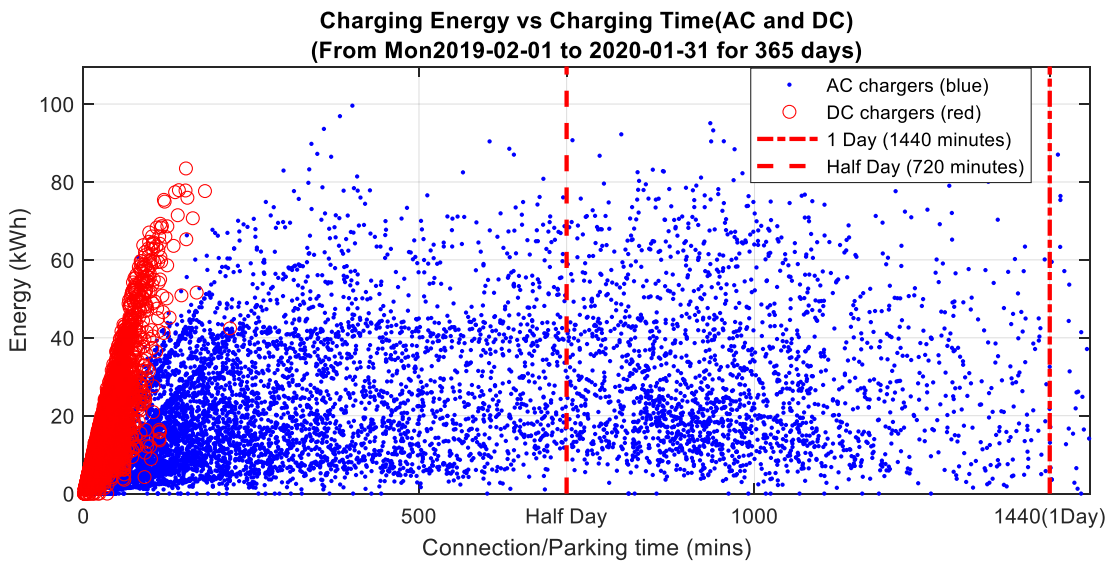

Figure 10: Overview of the charging demand vs. connection time duration over a period of one year

Charging events with a connection time up to 1000 minutes in the period 01/01/2017 to 06/11/2017 (310 days) are presented in Figure 11.

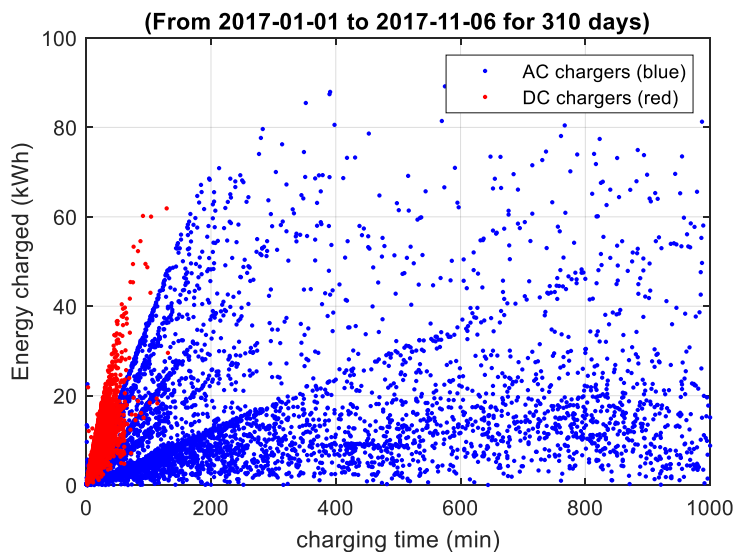

Figure 11: Event collection – charging demand vs. charging time duration



In Figure 12 (for the AC chargers) and Figure 13 (for the DC chargers), the relatively short-length charging part (up to 100 minutes of charging) is enlarged/zoomed in. Clear linear patterns radiated out are shown in Figure 12, and each clustered lines represent the charging rates options, i.e. 3.7 kW, 7.4 kW, 11 kW, and 22 kW. The patterns were not as clear for the DC chargers, see Figure 13. It can be seen from Figure 13 that the highest charging power is about 40 kW (corresponding to the energy charged in 60 minutes), which is less than the nominal 50 kW DC charging power.

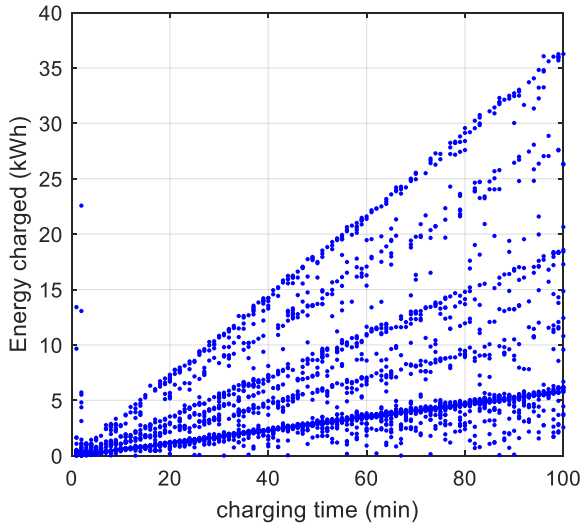

Figure 12: Zoomed in from Figure 11 for AC chargers

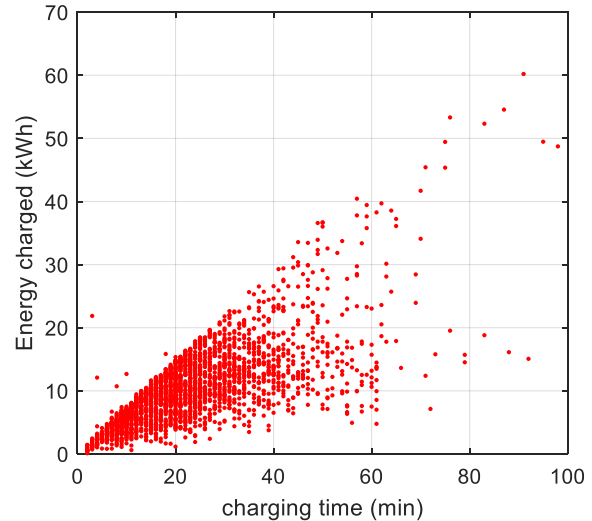

Figure 13: Zoomed in from Figure 11 for DC chargers

Uneven utilization of charging stations

Recalling Figure 8 showing the number of charging sessions for each charger, AC and DC, the utilization of the two DC chargers outnumbered that for the AC chargers. A more in-depth analysis of the number of charging sessions shows that the number of charging sessions are not evenly distributed between the AC chargers. In addition, the histogram of the charging duration, for both AC and DC chargers, is illustrated in Figure 9, where the frequency of charging duration decreased exponentially over time and short time charging (within half an hour) was the shown as the prevailing charging behaviour.

Furthermore, each charging event was scattered in Figure 11 between its charging electricity demand and charging duration, the relatively short-duration charging part (up to 100 minutes of charging) which is enlarged and presented in Figure 12 (for the AC chargers) and Figure 13 (for the DC chargers). Clear linear patterns radiated out are shown in Figure 12, and each clustered lines represent the charging speed options, i.e. 3.7 kW, 7.4 kW, 11 kW, and 22 kW. The patterns were not as clear for the DC chargers. It can be seen from Figure 13 that the highest charging speed is about 40 kW, which is less than the nominal 50 kW DC charging rate.

In addition, the utilization rate for each of the 52 EV charging stations are illustrated in Figure 14 in ascending order for the four respective seasons, where the utilization rate is calculated as the percentage of time that each EV charger is occupied for charging over the 6 weeks observation period for the individual seasons. It can be observed from this figure that certain charging stations have distinct usage patterns at certain time of day. For instance, P1012 – P1022 are mainly used in the midday and P1034 – P1043 are more occupied during the evenings. This may be due to reservation or the location of convenience for these chargers.

In addition, a clear increase in EV chargers' utilization rate can also be observed in Figure 14 from winter in 2017 to autumn in 2018, which is summarised in Table 9 in terms of the seasonal averaged and maximum utilization rate. It can be seen that the peak of utilization at each season occurred at early evening when the EVs returned from work, though the averaged utilization showed a very low number. This provides an opportunity to promote EV usage by increasing charger utilization. However, it is worth noting that the charging time would likely to be shorter than the actual connection time, during which EVs might still be connected to the EV chargers without exchanging energy.

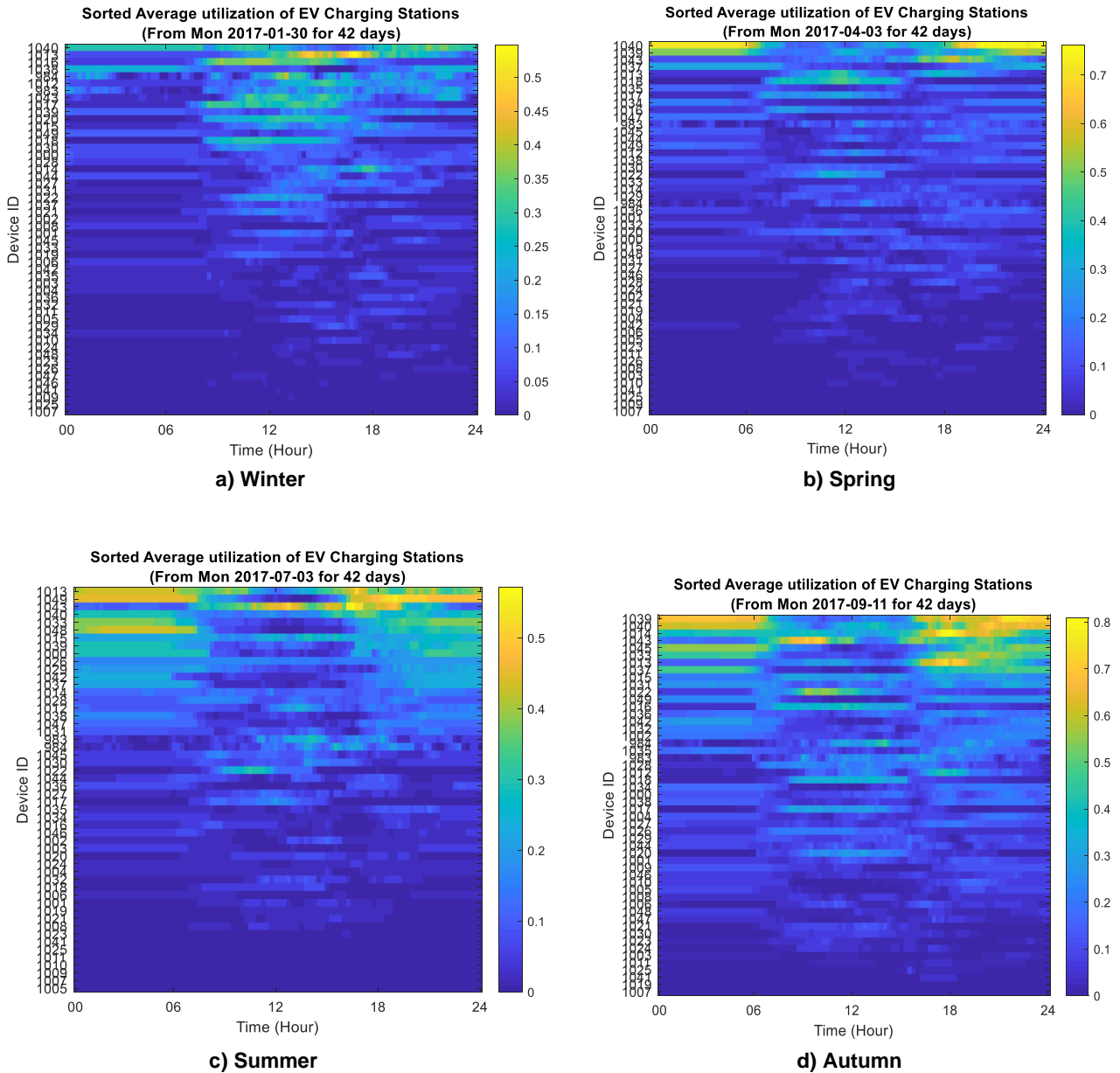

Figure 14: Seasonal EV charger utilization rate illustration

Table 9: Seasonal EV charger utilization rate summary

	Winter	Spring	Summer	Autumn
Average utilization rate	5.68 %	6.92 %	8.42 %	14.14 %
Max utilization rate	54.76 % @ P1013, 17:00	76.19 % @ P1040, 17:00	57.14 % @ P1043, 16:30	80.95 % @ P1014, 18:00

Another observation worth noting is that the EV users appear to be insensitive to charging cost, which is demonstrated by the insignificant change in the chargers' utilization rate before and after the introduction of the AC daytime charging fee. In fact, the average utilization rate has increased from 14.75% to 18.35%, by observing roughly two weeks on each side of the timeline of fee introduction.





2.2.2. Dataset 2 – load profile

Dataset 2 recorded hourly consumption profiles, though it is not clear what this is actually comprised of (not labelled on the Excel file received, and no clarification was ever possible to be obtained from the operational pilot partners on the ground). Without further information, the aggregated monthly energy consumption and the average daily load profile per month are calculated and presented in Figure 15 and Figure 16 respectively. Figure 15 depicts a significant year-on-year growth in energy consumption in addition to the seasonal pattern, where winter (in particular December and January) has the highest consumption. This is also confirmed by comparing the average daily load profile for each month in Figure 16. Furthermore, the average monthly energy consumption is calculated for each year and can be found in Table 10.

Table 10: Averaged Monthly Electricity Consumption

Year	Averaged Monthly Energy Consumption (kWh)
2017	16178
2018	34591
2019	59469

One interesting observation from Figure 16 is that the lowest power consumption at a day is between 5 a.m. – 7 a.m., rather than the between midnight to 4 a.m. This is possible due to the (residents’) EVs charging overnight, or because of an off-peak electricity tariff.

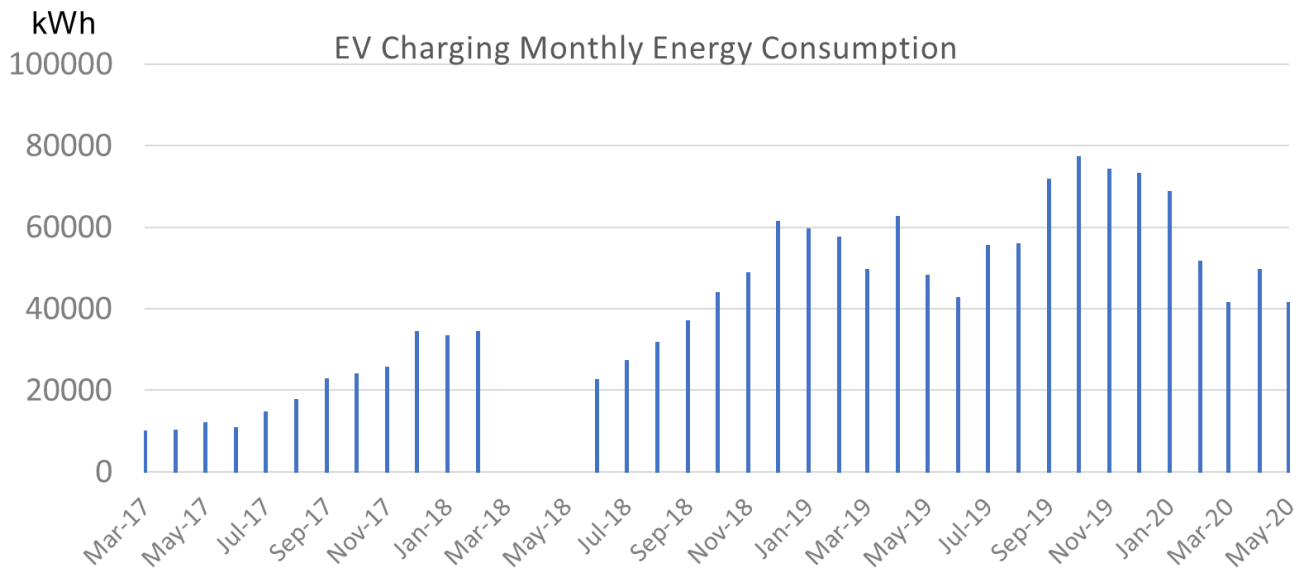

Figure 15: Aggregated monthly energy consumption of EV charging
(the monthly data for March 2017 was incomplete, and March-June 2018 were missing)



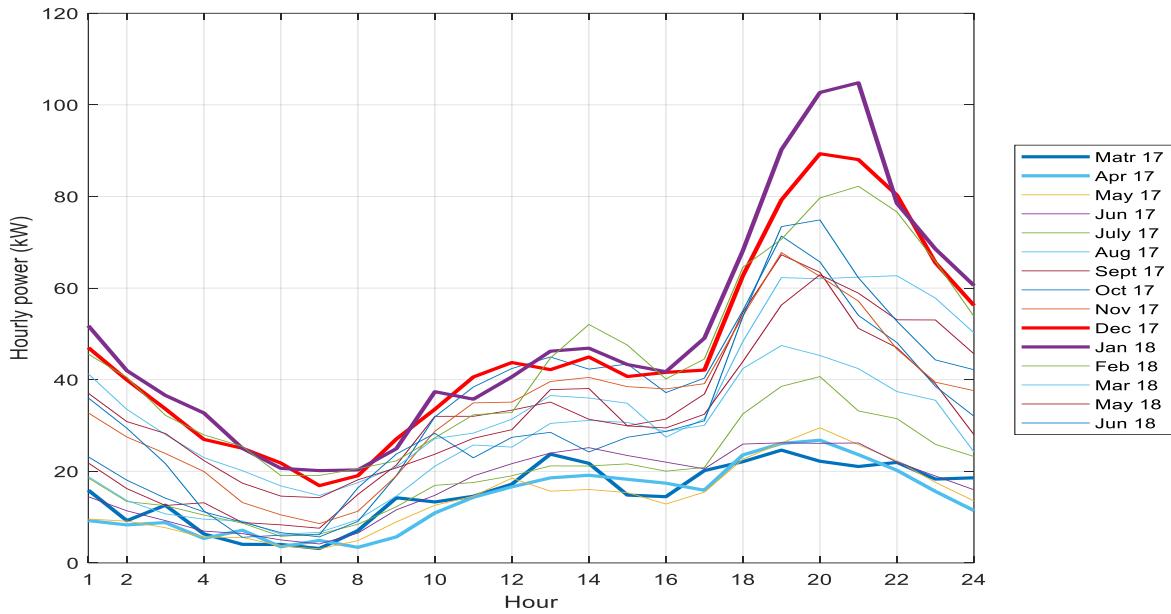

Figure 16: average daily load profile per month

2.2.3. Dataset 3 – Ferroamp database

The Ferroamp database is a comprehensive online data acquisition system that recorded the power flow related to the BESS, namely power imported from the grid, to the load and that exchanged with the BESS. A simple schematic of the Ferroamp system is illustrated in Figure 17, where the boundary that the consumption profile covers is again not clear. Without further available information, a few observations of the database as it is are presented as follows.

A gap of data record in the Ferroamp system can be observed in Figure 18 and Figure 19 between 13/04/2018 and 07/06/2018, for the profile of both grid import and load consumption, which might be due to a system update. A closer look at the different variables in the database is shown in Figure 20, using the week commencing 02/12/2017 as an example, where the BESS was scheduled to support the peak demand and the recharging took place when the load level is relatively low. The energy exchange of the battery storage in this chosen week of analysis however summed to -89.6 kWh, rather than being roughly energy neutral.

Considering that the convention adopted here for BESS scheduling is positive for discharging and negative for charging, this net charging consumption might be due to the poor efficiency of the storage system in the cycling process. Note that the Ferroamp installation recorded BESS power transfer on a 1 minute resolution.

The Ferroamp database showed that energy consumption for EV charging only represents a small portion of the total load, which – we have been informed (in March 2020) by both Fortum Charge & Drive and Ferroamp – is connected to the EV charging infrastructure and not to other major parts of the electricity consumption of the building. Therefore, the conclusion one could draw in the end, if the very belated information from Fortum Charge & Drive and Ferroamp is indeed correct, is that Dataset 1 is in fact only partial and flawed. It is unclear where and how in Fortum this emerged, as it was forwarded to UNN indirectly.

The fact that Dataset 1 on the EV chargers in Excel format is probably only partial and not fully reliable has been indicated twice: once by a Nordic back-office data analyst of Fortum Charge & Drive in 2018 (Oscar Ekman) and, more recently in March 2020, by a representative (engineer) of Ferroamp (Bjoern Jermström).



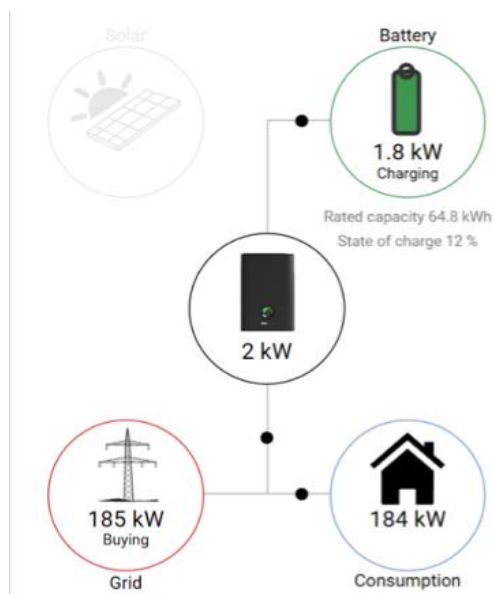

Figure 17: Schematic of the Ferroamp system (screenshot for a power exchange instance)

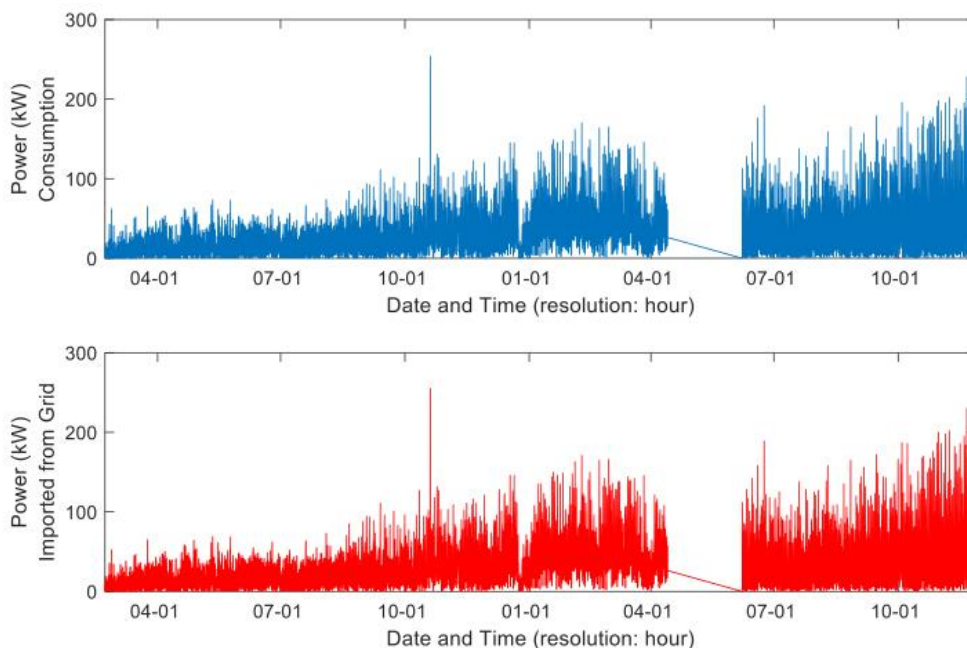

Figure 18: Time series of profile for grid import and load consumption from February 2017 to November 2018 (the format for the horizontal axis's label is month-day)

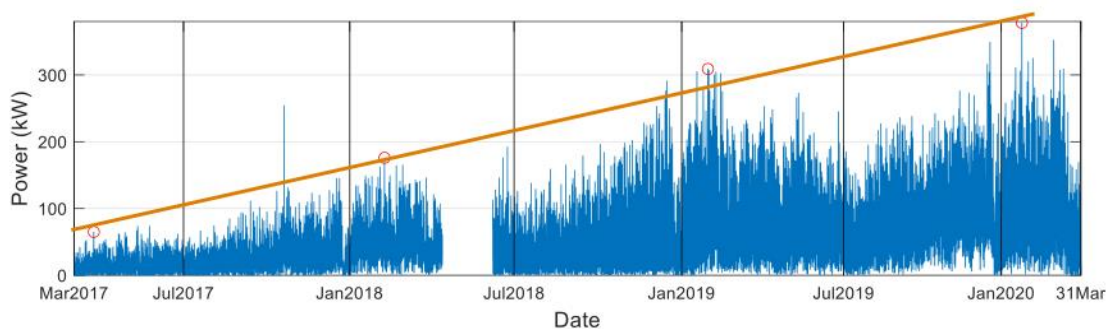

Figure 19: The power imported from the grid during a 3-year period (02/03/2017-31/03/2020) based on the data from Ferroamp. The orange line corresponds to the maximum peak power in each year (highlighted by red circle)





Figure 19 shows the power imported from grid during a 3-year period (02/03/2017 – 31/03/2020). The resolution is at an hourly level. A gap during between 13/04/2018 and 07/06/2018 is due to unavailable data during that period. A yearly periodic pattern can be seen clearly from the three years of historic data. Winter months have the highest demand on electric energy, while the summer months demand less electricity. Furthermore, the red circles in Figure 19 indicate the peak power at each year, which are about 64.9 kW on 28th March 2017, 176 kW on 08/02/2018 7 p.m., 309 kW on 29/01/2019 7 p.m. and 378 kW on 21/01/2020 6 p.m. The power demand shows a steady increasing trend at a rate of roughly about 100 kW per year.

The earliest likely reliable peak power measurement was taken on 28th March 2017, when a peak power reading of 64.9 kW was recorded. Even though the BESS was then in operation, and was in principle ready to act to reduce the level of peak power demand from the grid, demand was below the 200 kW cut in point, so no BESS output occurred – as per the system pre-set logic. Towards the end of the OP, the highest peak reading occurred on 23rd January 2020, recorded as 378 kW. From the system data analysed, no significant BESS output was measured even though the cut in point had been exceeded. The reasons for this lack of output from the BESS are not clear, though it could possibly be due to the way the BESS is set up to do both phase balancing and peak demand response.

The usage of the EV chargers in the Vulkan car parking garage increased throughout the duration of the OP (until the COVID-19 restrictions impact reduced it again from the high point it had reached). If the BESS had in fact acted with its full 50 kW rated power, it could have reduced the peak power level recorded on 28th March 2017 by 77% and that recorded on the 23rd January 2020 by 13%.

As an example of the possible peak shaving performance of the BESS system, between 1.31 p.m. and 2.31 p.m. on the 23rd March 2017 a peak grid power input of 46.5 kW with a peak battery output of 25 kW was recorded. The grid provided 17.6 kWh during the hour, and the stationary battery provided 3.1 kWh. Given the power and capacity of the BESS system, the peak could have been fully accommodated by the battery with its potential 50 kW power (bi-directional inverter) and its 50.4 kWh capacity. In fact, the operating conditions (as advised by Ferroamp in March 2020) would have prevented such an operation, and should in fact have prevented any discharge from the BESS since the grid load was under 200 kW.

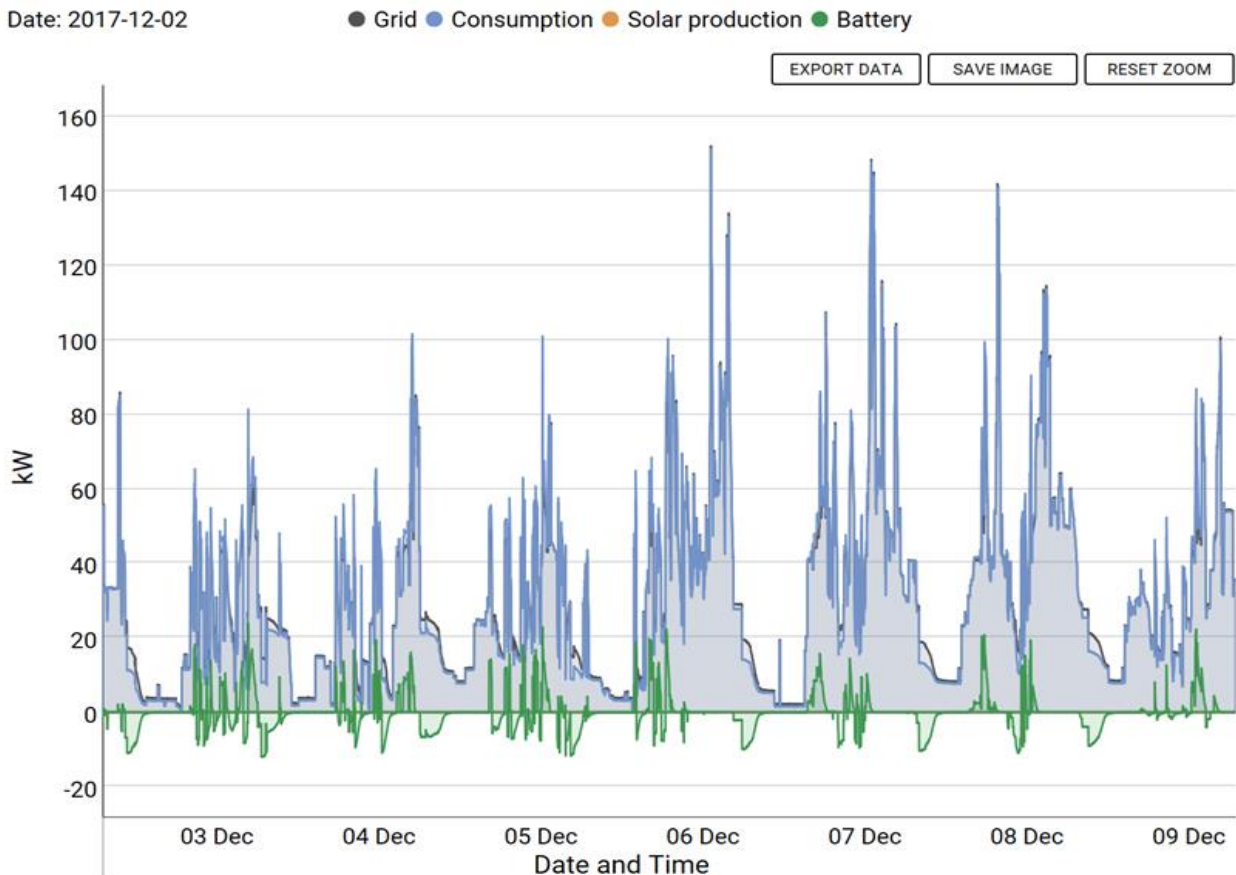

Figure 20: Ferroamp system’s record on the power flow for the week commencing 02/12/2017





2.2.4. Data availability evaluation

The data analyses presented in this section show that the Ferroamp database includes the load profile recorded in Dataset 2, even though the exact boundary covered by the profile is not clear. It can be seen from Table 7 that the common data availability period, i.e. between Dataset 1 and 3, is 21/02/2017 – 16/11/2017, which is before the smart charging functionality was enabled for the AC chargers.

Further analysis could be conducted in the future, in order to improve the overall energy management of the building via smart EV and BESS control, if the following information could be made available:

- An up-to-date EV charger dataset, covering the period when smart charging functionality became enabled for analysing the smart charging performance of pilot baseline and for evaluating the improvement achieved in KPIs by implementing eV4ES.
- Apart from the charging durations, the data of periods when the EV is connected to the charger without charging actions could also be provided, either as part of Dataset 1/ Dataset 3, or as a separate file. This would provide the EVs' availability for smart charging management.
- Parking data from One Park, the parking manager, would be required for implementing and analysing the smart parking management in order to maximize the garage utilization and to promote EV use.



3. SEEV4-City Results – Key Performance Indicators (KPIs)

This section introduces the approach of KPIs quantification, namely energy autonomy, CO₂ emission reduction and savings due to grid investment deferral that are used within the scope of SEEV4-City project. The economic feasibility of the proposed business model (with associated EV4ES) was compared with a baseline case which reflects the current status of the operational pilot.

The baseline case was derived from the operational pilot data records. Smart charging and smart parking management, as detailed in section 2, are used to demonstrate the improvements the proposed business model can bring into the baseline case in terms of the KPIs, i.e. CO₂ emission reduction, grid investment deferral, and overall improved economics (total cost of ownership (TCO) / total cost of use (TCU)).

3.1. Methodology

Each of the SEEV4-City pilots adopt different system components and have their own approach within its system boundaries. They do not all use the same combination of components but all adopt variations of a base set of 'building blocks' as visualised in Figure 4. The SEEV4-City project recognised the potential value in identifying the benefits of individual energy system components (such as PV, BSS and EV battery as storage) for design decisions for a specific location in relation to the project's main KPIs, for CO₂ reduction and grid investment deferral in particular.

In addition to the three main KPIs, the objective for the Oslo pilot is to include optimal charging of incoming EVs at the minimum electricity cost while complying with the maximum network constraint, achieved by BESS peak shaving. For this purpose, the optimization problem is formulated as a linear cost-minimization algorithm. Equation (1) expresses the objective function, subject to constraints expressed in Equations (2) – (5).

$$\min_{\mathbf{P}^{Tot}} c_e = \boldsymbol{\pi} \mathbf{P}^{Tot} \quad (1)$$

$$P_t^{Tot} = \sum_{i=1}^{n^q} P_{i,t}^{EV} \quad (2)$$

$$\begin{cases} E_{1,t^d}^{EV} \geq E_1^{req} \\ \dots \\ E_{n^d,t^d}^{EV} \geq E_{n^d}^{req} \end{cases} \quad (3)$$

$$P_t^{Tot} + P_t^B \leq P^{MAX} \quad \forall t \quad (4)$$

$$P_{i,t}^{EV} \in 3.7 \times [1,2,3,6], P_{i,t}^{EV} \in \mathbb{N}, \forall i, t \quad (5)$$

The objective of the optimization is energy cost minimization. This is expressed by equation 4, where c_e is the energy cost, $\boldsymbol{\pi}$ is the wholesale market price and $\mathbf{P}^{Tot} = [P_1^{TOT}, \dots, P_t^{TOT}, \dots, P_T^{TOT}]^T$ is the vector of the total charging power of the e-car-park. Equation (2) expresses the relationship between the charging powers $P_{i,t}^{EV}$ of the n^q EVs that are currently in the queue and the total power of the e-car-park P_t^{Tot} for each time step t . The EV charging requirement is expressed by Equation (3) where $E_{1,t^d}^{EV}, \dots, E_{n^d,t^d}^{EV}$ are the energy of the n^d EVs that will depart at time t^d and $E_1^{req}, \dots, E_{n^d}^{req}$ are the energies requested by the respective EVs. Equation (4) represents the constraint due to the system specification, which limits the overall power of the e-car-parking garage and the building demand P_t^B to $P^{MAX} = 700 \text{ kW}$ (the OP stated that this was the preferred safe upper limit to be targeted).

Finally, due to the multiple charging rates available in the EV chargers, only 4 charging speeds are chosen (3.7 kW, 7.4 kW, 11.1 kW and 22 kW), as expressed by Equation (5).

The SEEV4-City project has chosen to define several sub-indicators for KPIs A and C for the purpose of capturing potential additional insights in relation to CO₂ reduction and grid investment deferral objectives, and the role these different components may play.



The methodology for calculating their contributions is described in more detail in the project's KPI Baseline and Methodology Report. The identified sub-indicators within the methodology are:

KPI A – CO₂ reduction

- CO₂ related to baseline demand;
- Zero Emission kilometres increase.

CO₂ emissions savings consist of ICE substitution (by EV), where the different lifecycle emissions of ICE and EV have been considered.

KPI B – Energy autonomy

- Self-consumption. No longer applicable for this OP, as decision was made by the Oslo Vulkan car parking garage (and estate) owner that a PV installation was no longer part of the installation design. The initial indicated 8% Autonomy is no longer available as part of the baseline. In this report, the methodology for energy autonomy is included as part of the KPIs, but the associated evaluation is not implemented as no renewable energy generation was installed, which means there will be no increase in EA achieved for the Oslo Vulkan OP.

KPI C – Grid investment deferral

- (relative) Peak power demand reduction for EV charging / Peak shaving by use of the BESS (which sources fully renewable energy from the central grid).

3.2. Baseline and Final measurements

The methodology presented in section 2 has been implemented with the pilot data, and Smart Charging has been applied to achieve KPI improvements. There are two scenarios explored here: Baseline and Smart Charging.

An example of a typical day is presented in Figure 21, where the charging scheduling for both baseline and Smart charging is provided along with the wholesale electricity price in Oslo [4]. It can be seen that under the smart charging approach, charging of the BESS happens as much as possible during low price periods. The assumption here is that in an 'ideal' electricity peak-shaving (though perhaps not battery degradation of the BESS), the BESS would be almost fully discharged at EV charging infrastructure peak demand times. Hence this assumption results in the model inter-exchangeability of smart charging of the BESS and EV charging in Figure 21. Furthermore, the charging required by EVs departing, for example at 16 hrs, is satisfied.

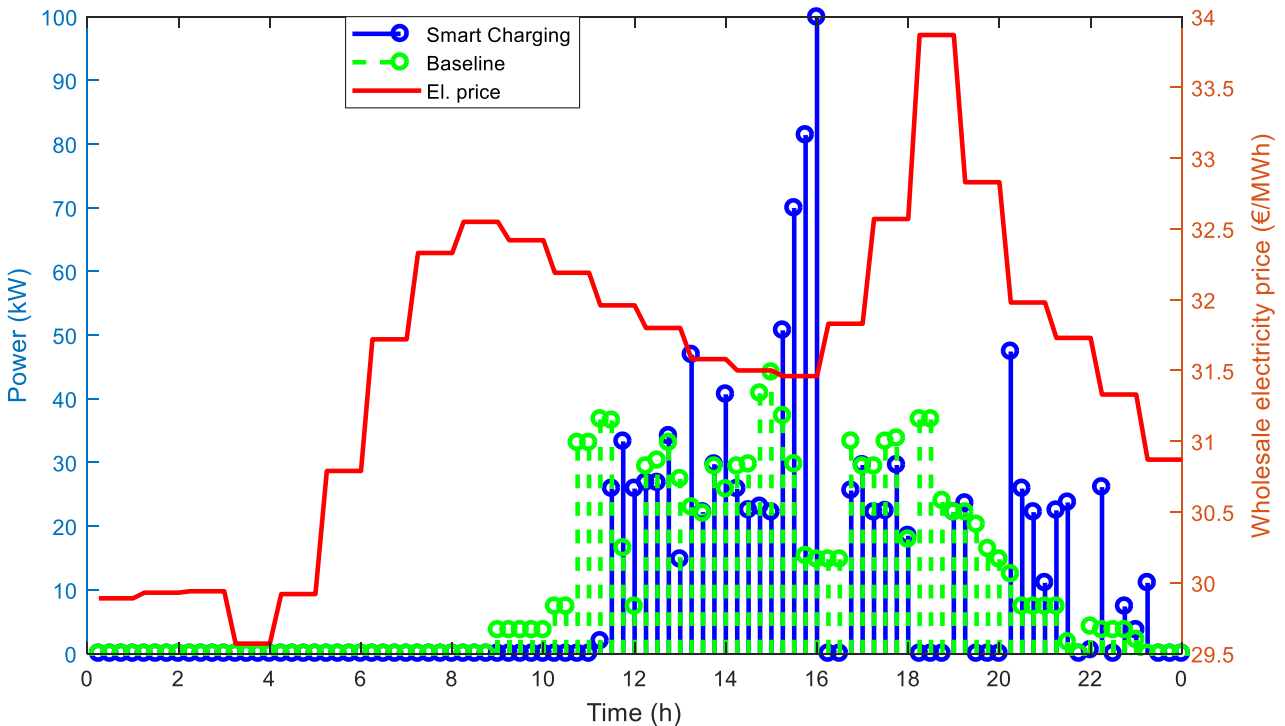

Figure 21: EV charging scheduling for baseline and smart charging



3.2.1. Component data requirements

Data requirements are specified in Table 11.

Table 11: Oslo Vulkan Car Parking Garage OP Data Requirements

KPI A CO₂	
Connection start time and date	Time and date
Connection end time and date	Time and date
Connection duration	Time in hours
Energy	Amount of charge in kWh
Charging connector	Device ID and Socket type used
KPI C Grid investment deferral	
Energy imported from grid	Hourly figures
Energy consumption	Hourly figures
Energy exchange with BESS	Hourly figures
Power imported from grid	Hourly figures
Power consumption	Hourly figures
System Electrical Diagram	Clear functionally representative schematic

3.2.2. Baseline and Final measurements

The Baseline (relevant to OP's initial values obtained at the at commencement of the project) and Final Evaluation of KPIs are summarised in Table 12; the relevant calculations are presented in Table 16.

Table 12: Baseline and Final measurements relating to the KPIs

		(i) Initial stage	(ii) End of Project	
		Value	Value	Compared to (i)
A. CO₂ Reduction				
A.1	Pilot CO ₂ footprint	0	- 912 tons/year	- 912 tons/year
A.1.1	CO ₂ related to baseline demand	0	0	0
A.1.2	CO ₂ related to use of battery: EV	0	14.3 tons CO ₂ /year	14.3 tons CO ₂ /year
A.1.3	CO ₂ related to use of battery: BSS	0	0	0
A.1.5	ICE replacement CO ₂ savings (EV)	0	912 tons/year	912 tons/year
A.1.6	Zero Emission kilometres increase (EV)	0	4,210,405 km	4,210,405 km
B. Energy Autonomy Increase				
B.1	Self-Sufficiency	0	0	0
B.2	Self-Consumption	0	0	0
C. Grid Investment Deferral				
C.1(a)	Peak Demand Value	64.9 kW	378 kW	313.1 kW
C.1(b)	Percentage reduction in peak demand value if BESS had been fully applied	77%	13%	-64%

3.3. KPI results conclusions

The reduction in CO₂ emissions achieved was comfortably in excess of the original pilot target. The original target was 90-120 tons/year reduction; in fact, a reduction of over 912 tons/year resulted from the pilot. The 4,210,405 zero km/year achieved represents a very significant increase factor, well above the original target of 1.5x which would correspond to 1,062,000 zero km/year.

Energy Autonomy did not increase since no source of local generation was included in the pilot in its final form.

The operation of the obsolete Schuko EV chargers is not considered, due to a complete absence of data.

Within the SEEV-4 Project methodology there was no grid investment deferral; at the commencement of the project peak demand value for EV charging was 64.9 kW; at the end it had risen to 378 kW. The effect of the BESS system, if it had been applied, can be clearly seen. It would have reduced the peak demand from the Grid by 77% at the beginning of the OP and by 13% at the peak demand level towards the end of the OP. As peak demand rises, the percentage effect of the fixed output BESS system will necessarily fall. One may see that the effect of the 50 kW BESS could be to postpone to some degree the date at which the steadily increasing peak demand level, if projected forwards, eventually reaches the 800 kW system limit. However, no Grid investment deferral occurred during the OP itself.

3.3.1. Increasing EV users in Oslo and Norway

A peak in EV uptake in Oslo was noticed in September 2018, with a 70% market share of newly sold cars for EVs, see Figure 22. This was partly due to new EU regulations that require the new type approval methodology (Worldwide Light vehicle Test procedure 'WLTP') for all car models from September 1st 2018. Sales for several EV models had been put on hold, while waiting for WLTP approval.

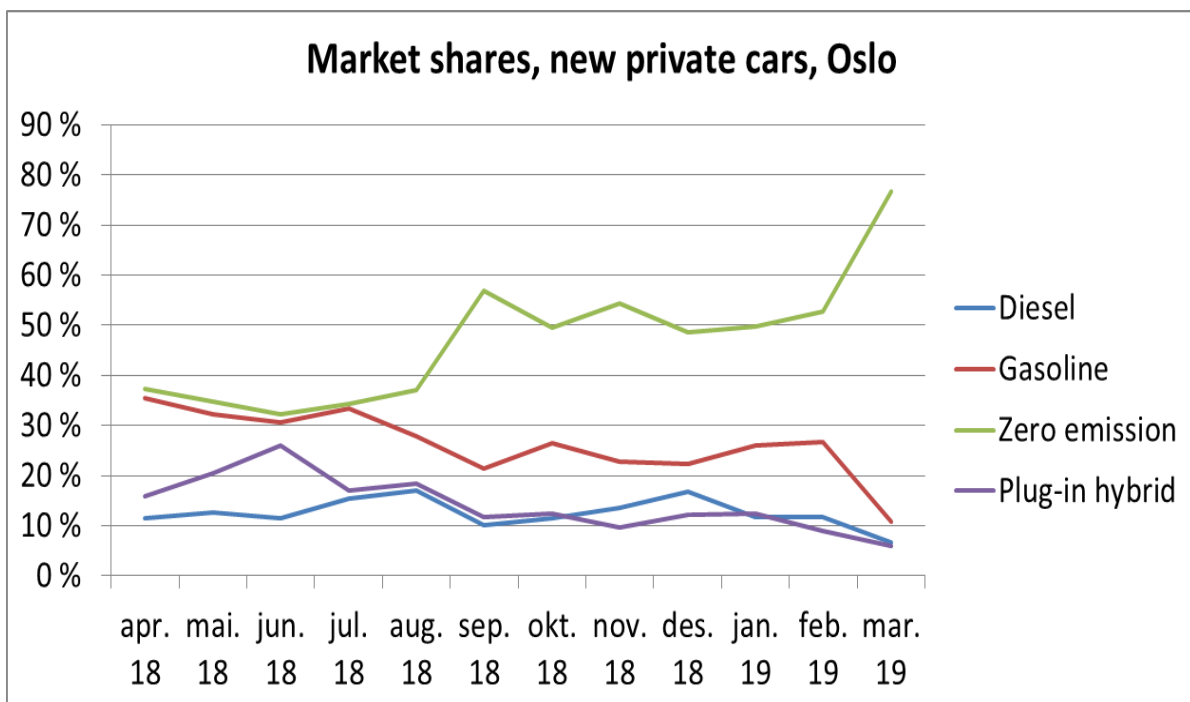

Figure 22: Market share of sales of new private vehicles between April 2018 and March 2019

When the EV penetration in Oslo reaches significantly higher levels, this would presumably then be reflected in the Vulkan car parking garage, where both EV car parking spaces and EV chargers should see higher demands, and grid investment may well be needed down the line. Figure 23 shows the market shares for new types of cars in Oslo in September 2019. It can be seen that 77% of the new cars sold in Oslo are BEVs, and in addition a not insignificant share are PHEVs.

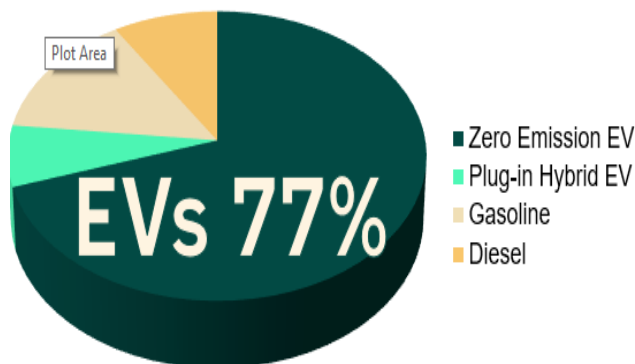

Figure 23: Market shares for sales of new cars in Oslo, September 2019

The share of BEVs and PHEVs in Oslo reached 68% in 2019. BEV and PHEV make up a share of sales of 76% so far in 2020.

Figure 24 depicts the increasing trend of the market share for EV cars (zero emission cars) over the past 9 years. It can be seen that, in 2019, it is expected that 60% of newly registered cars in Oslo are EVs, with the market share of EVs of new registration at about 45% across the whole country.

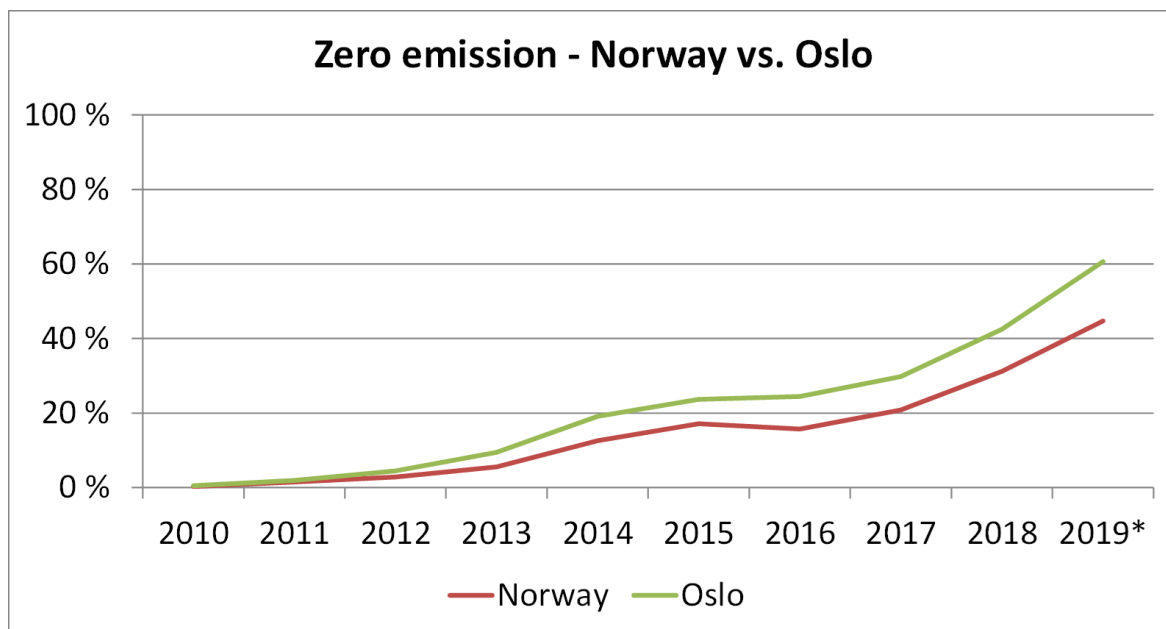

Figure 24: Norway’s and Oslo’s trends of the increasing market share for new ‘zero’ (tail-pipe) emission cars

In Figure 25, the percentage of the EVs and ICEs (both gasoline and diesel) is with respect to the total stock of cars. The diesel car share (brown lines) increases from 25% in 2008 to 45% in 2014, which represents the share of the total car stock. Since 2014, the share of diesel cars in Oslo have decreased significantly, while the share of EV cars has increased steady. From Figure 25, it is estimated that the EV share of the total car market share in Oslo increases by about 10%, from 15% in 2017 to 25% in 2018.



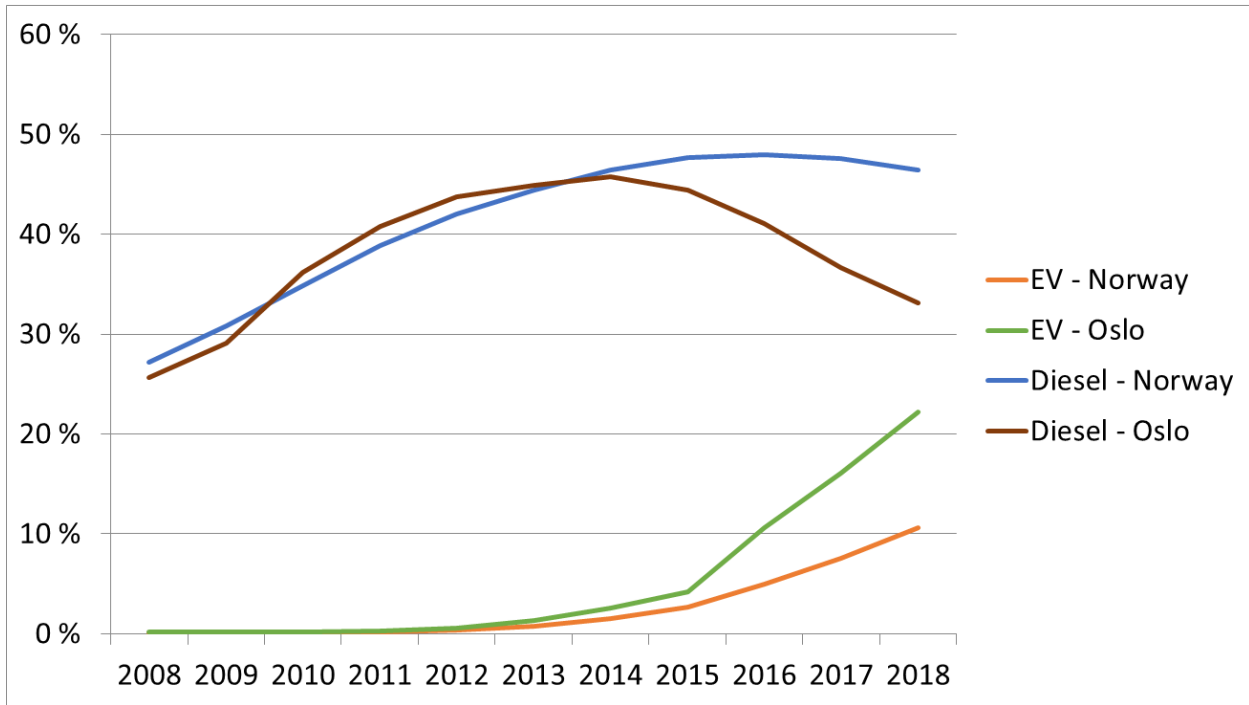

Figure 25: Market shares of total car fleet for Oslo and Norway

The increasing trend could reflect Oslo City Council’s promotion to the EVs. In March 2019, Oslo City Council introduced a new policy for public/on-street EV charging with immediate effect:

"Electric car drivers in the capital of Norway must now pay for charging. Oslo has started the conversion of about 1,300 public charging points in the city to be able to charge a fee. The aim is not so much to cash in but to keep EVs from parking for free without charging. Starting immediately, Oslo City Council will charge ten crowns (approx. 1 euro) per hour during the day and five NOK per hour at night. At the same time, there are also plans to increase the number of charging stations to 2,000 by the end of the year." ²²

In 2024, the area inside Ring (road) 3, extended central Oslo, will be for EVs only, and the Vulkan car parking garage is well within Ring 3. And in 2025, the ban on sales of diesel and gasoline vehicles will be in force in all Norway.

From Figure 23, Figure 24 and Figure 25, it can be concluded that more than 60% of all new cars sold in Oslo in 2018 were electric. In 2019, this proportion increased to 77% (January to September). From 2023, there will only be ‘zero-emission’ taxis (that is, EVs and hydrogen cars) allowed in Oslo.

Assume the total number of cars in Oslo is not to change, this suggests that 10% of cars in Oslo will be replaced by EVs every year (Figure 24). Assuming the percentage of EVs of total cars in Oslo is 35 % in 2019 (increasing 10% from 25% in 2018), Oslo will reach the target of no ICE cars in late 2025, at the EV increase rate of 10%. This is in line with Oslo City Council’s policy initiative.

3.3.2. CO2 Reduction or Savings

Since 98% of Norwegian energy demand is supplied by hydro-power generation [2], [4] ²³ and at least another 1% in Oslo is from wind, the reduction on carbon footprint due to smart energy management (such as load shifting) is negligible. In this report, the CO₂ emission savings for the Oslo operational pilot is calculated from the following indicator. There was no (EV) car-sharing provision of EVs at the Vulkan car parking garage prior to 2017. However, there were 50 old Schuko EV charging outlets, and most of them were removed in 2017 when the modern EV charging installations were put in through SEEV4-City with only 12 of them remaining on the ground floor. For the purpose of this pilot, the obsolete Schuko chargers are not considered.

²² <https://www.electrive.com/2019/03/03/oslo-charging-electric-cars-no-longer-free-of-charge/>

²³ And the remainder in eastern/south-eastern Norway, including Oslo, comes from wind, <https://www.electricitymap.org/zone/NO-NO1>





ICE replacement CO₂ savings – km driven

CO₂ savings with car replacement can be achieved by replacing a car/van by a more energy-efficient and therefore more CO₂-efficient transportation alternative (ICE replaced by EV).

The values for CO₂ emissions per km driven, as given in Table 13, are used in the following analysis (table taken from Hoekstra) [6]:

Table 13: CO₂ emissions per km driven [6]

	Buchal et al. ⁵	Hoekstra et al. ⁹	Renewable Future
Diesel Car Total	170	244	153
Driving	143	217	150
Manufacturing	27	27	3
BEV Total	189–214	95	10
Driving	73	55	6
Manufacturing	100–125	40	4
(Battery)	(73–98)	(16)	(2)

According to [6] published in 2019, a diesel car will have 217 gCO₂/km direct emissions (combustion of diesel) and 27 gCO₂/km indirect emissions (manufacturing). By contrast, a battery electric vehicle (BEV) might have a total of 95 gCO₂/km emissions, if, as in Table 13, 55 gCO₂/km relates to the emissions associated with generating the electricity used to propel the EV, 40 gCO₂/km are associated with the manufacture of the BEV and 16 gCO₂/km are recovered when the battery is recycled. For the calculations for the Oslo OP, electricity generation can be taken to be purely hydro-electrically based, with generation emissions of 20 g/kWh [7]. As will be shown in section 4.3, the weighted average efficiency of BEVs in Oslo is 5.9 km/kWh, meaning that the emissions associated with generating the electricity used to propel BEVs in Oslo would be 3.39 gCO₂. Thus, total emissions for Oslo BEVs are net manufacturing 24 gCO₂/km, and driving emissions of 3.39 gCO₂/km. Total effective BEV emissions amount to 27.39 gCO₂/km, after allowing for EV charging and LV distribution losses.

Consequently, the calculation per year for CO₂ savings due to car replacement is:

$$ICE\ replacement\ CO_2\ savings = \sum_{t=1}^{T^S} (d_t^{CO_2\ replacement} - d_t^{CO_2\ original}) * D_t \tag{6}$$

Where

- $d_t^{CO_2}$ is the emission factor per km for the vehicle in question for each timestep
 - 244 gCO₂/km for a diesel ICE car;
 - 27.39 gCO₂/km for a BEV.
- D_t is the distance driven in km over that timestep;
- The usage of the vehicle is restricted to working days (on average, 230 in Europe).

Note: Timestamp not needed: daily total.

For Oslo OP, ideally there would be two possible approaches:

- We just/only count the permanently placed BEVs at the Vulkan car parking garage through the car rental companies, provided they would tell us a) the number, b) the breakdown between BEVs and PHEVs and the respective car models. We could then assume that those EVs replaced ICEs which would otherwise have been placed (or indeed in part were actually placed) at the Vulkan car parking garage as the service provision (pick-up/return and EV charging) location. However, this information has not been supplied by the Operational Pilot;
- We take the estimated number of BEVs (with an estimated number of BEVs and PHEVs) per (week-) day which are public users, residents and professional (craft & service) users based on a rule of thumb from the electricity consumed and models on the Oslo/Norwegian car markets for EVs (BEVs and PHEVs). However, in this OP no information was made available as to the numbers and types of BEVs being charged.

Accordingly, it was necessary to calculate the weighted average driving efficiency of Norwegian BEVs, assuming that this will represent the BEV charger usage at the Vulkan car parking garage. Then, since we know





the average monthly energy charged through the EV chargers at the Vulkan car parking garage, CO₂ savings and annual ZE km (km driven with charged kWh) may be obtained.

Savings due to ICE substitution – lifecycle considerations

This takes into account the difference between the CO₂ emissions in the lifecycles of ICEs and EVs, covering all the stages of manufacturing, operation, maintenance and decommissioning. During each of these stages, a certain amount of CO₂ is emitted. To allow for a fair comparison, the whole lifecycle for both types of vehicles must be taken into account. It is worth noting that, within the scope of SEEV4-City project, the operation of the vehicle is the only controllable part; the other three dimensions are driven by technology advancement and penetration level of the technology.

Based on much older (2010) data shown in Figure 26, CO₂ emissions due to manufacturing, maintenance and decommissioning phases for EVs (totalling 65.28 g/km) are almost double those for ICE vehicles (34.45 g/km). This is due to the considerable CO₂ emissions in the manufacturing of the EV battery. It is worth pointing out that with the continuous advancement of EV manufacturing processes (for which some OEMs now use renewable non-fossil-based electricity) and in battery technology as well as the utilization of automotive batteries in second life applications, these figures will significantly improve in favour of EVs [8], [9]. In fact, predictions suggest a CO₂ emission value of 15.53 g/km for EVs in 2050 excluding the operation of the vehicles [8]. In the case of second life battery usage, the overall CO₂ emitted from the aforementioned three phases of the life cycle is distributed over a longer period and therefore the emission per km (or kWh) can be reduced further. Consequently, the CO₂ emissions savings due to the operation of the electric vehicle, in comparison with the ICE, must at least compensate for the inherent CO₂ emission penalty due to manufacturing, maintenance and decommissioning.

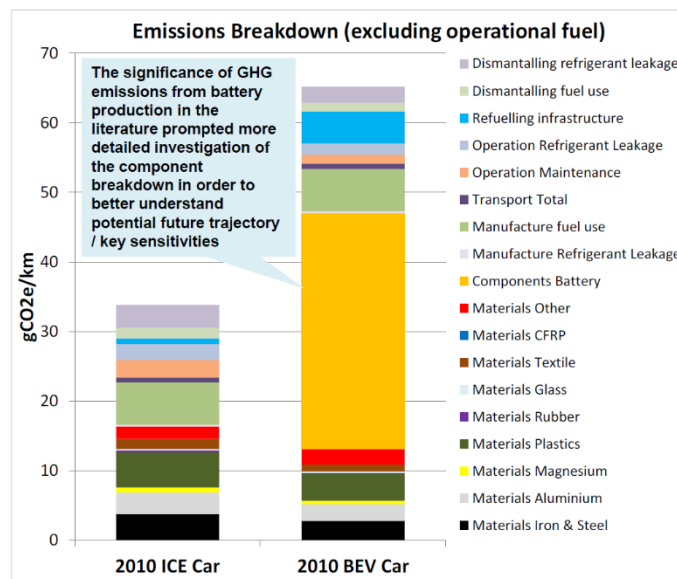

Figure 26: CO₂ emissions for ICE and EV for manufacturing, maintenance and decommissioning [8]

The CO₂ emission caused by ICE operation is due to both the well-to-wheel and tailpipe emissions. The average value for European ICEs of 217 g/km [6] is used for the carbon footprint evaluation in this report.

The CO₂ emission due to EV operation depends on the marginal national/regional energy mix that is used to charge the EV battery (kWh) for driving purpose, and this varies from country to country. As can be seen from Figure 27, the average European EV operational emission is much higher than that of France (which is mainly powered by nuclear) and Norway in this case presents a near zero-emission electric transportation due to the dominance of hydro-powered energy as mentioned earlier. To be more precise, the lifetime CO₂ emission for hydroelectric is 20 g/kWh [7], which is converted to roughly 3.3 g/km using the technical data of the most popular BEVs in Oslo. This leads to a huge margin of environmental benefits achieved by EVs when compared to ICEs, regardless of the scheduled EV charging time of the day.



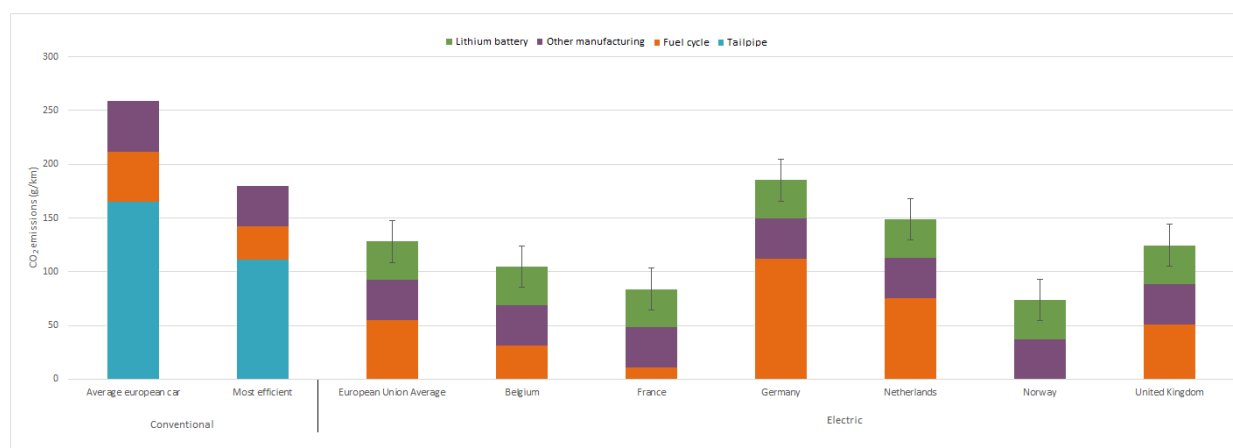

Figure 27: CO₂ emissions due to the operation of ICE and EV in Europe [9]

Table 14 summarises the CO₂ emissions values at different stage of lifetime for ICE and EV in the Oslo pilot. It can be seen that by replacing an ICE with EV, 176 grams of CO₂ could be saved per kilometre driven.

A latest update is that, due to new COVID-19 measures (since 12th March 2020) and the relative absence of customers, a drop in the use of EV chargers at 36% (based on electricity demand) is observed at Vulkan car parking garage.

Table 14: Life cycle assessment of CO₂ emission savings by ICE substitution in the Oslo Vulkan car parking garage operational pilot

CO ₂ emission	ICE	EV	Savings in CO ₂ emission
Manufacturing, maintenance, and decommissioning (g/km)	27	24	3
Operation (g/km)	217	3.3	213.7
Lifetime CO₂ emissions (g/km)	244	27.3	216.7

Summary:

The replacement of ICE vehicles by BEV resulted in a decrease in manufacturing-related CO₂ emissions of 3 g/km, on the assumption that the BEV batteries were (will be) fully recycled at end of life. Diesel operational emissions totalled 217 g/km, giving rise to an operational saving by ICE substitution of 213.7 g/km.

3.3.3. Energy Autonomy increase

As explained earlier, the initial design idea for the Oslo Vulkan pilot included the installation of a PV installation; however, during the process of determining the actual design this was decided against by the building owner / the local OP. Therefore, there is no PV installation in the Oslo pilot to be considered for the KPI result reporting.

3.3.4. Grid investment deferral

At the commencement of the Pilot peak charging level was 64.9 kW. Towards the end of the Pilot, peak demand for EV charging reached 378 kW. In both cases, data collected showed that there were no effects of the BESS system in peak reduction at these power levels. Therefore, within the context of the SEEV4-City project methodology there was no reduction in peak demand within the pilot’s duration, and thus no demonstrable grid deferral. This could be due to the way the BESS system was set up. However, future possibilities based upon measured trends do show worthwhile projected results from the OP with potential grid deferral delay, under the assumptions of a full use of the BESS and a linear increase of EV charging infrastructure demand. Note that ‘other loads’ of an unknown identity were identified but due to lack of data (and also being of insignificant power), these loads were ignored.

The capacity of the BESS is 50.4 kWh, which is relatively small when compared with the measured consumption loading of the SEEV4-City Vulkan car parking garage (i.e. the EV charging infrastructure, plus perhaps some





‘other loads’ of an unknown identity), which peaked in March 2020 at some 378 kW. Results from 2017 are shown in Figure 28 and Figure 29. Although the BESS is used for peak-shaving and is capable of reducing the peak-power part of the electricity power bill, the output of the stationary energy storage system is constantly small even if used to its full capacity effect, limiting the level of reductions in peak grid demand. The degree to which grid investment deferral is affected relates here to EV charging, which is the focus of this OP. The very significant increase in the use of the EV charging infrastructure in the Oslo car parking garage is a success of the OP, especially for KPI A on CO₂ emissions reductions through decarbonisation of mobility/transport, as the electricity provided to the EVs via the EV charging infrastructure is at least 99% from renewable sources (hydro power from the grid).

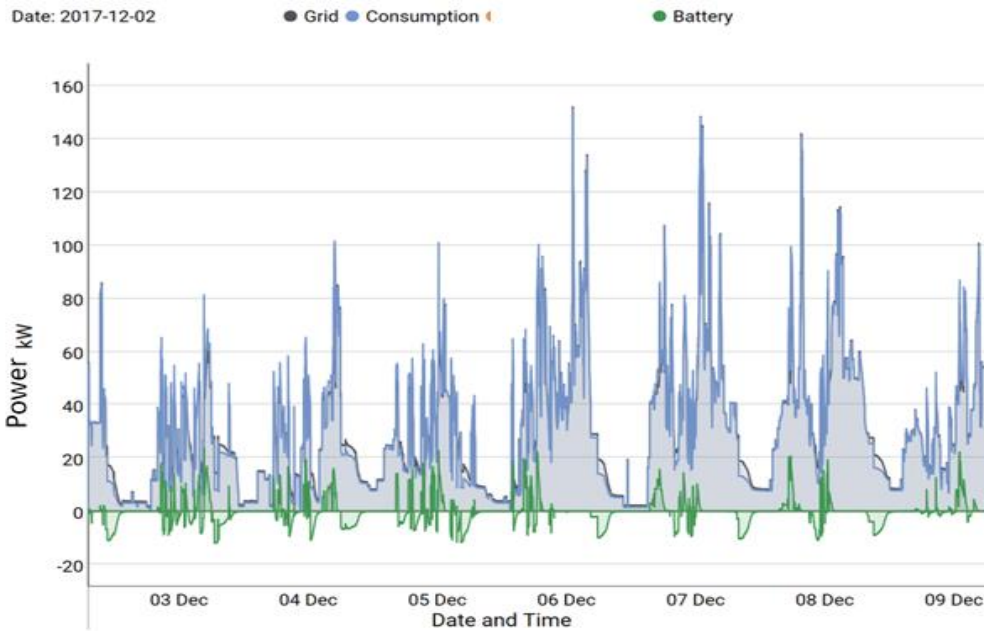

Figure 28: Power of electricity imported from the grid (black), consumption (blue) and BESS (green)

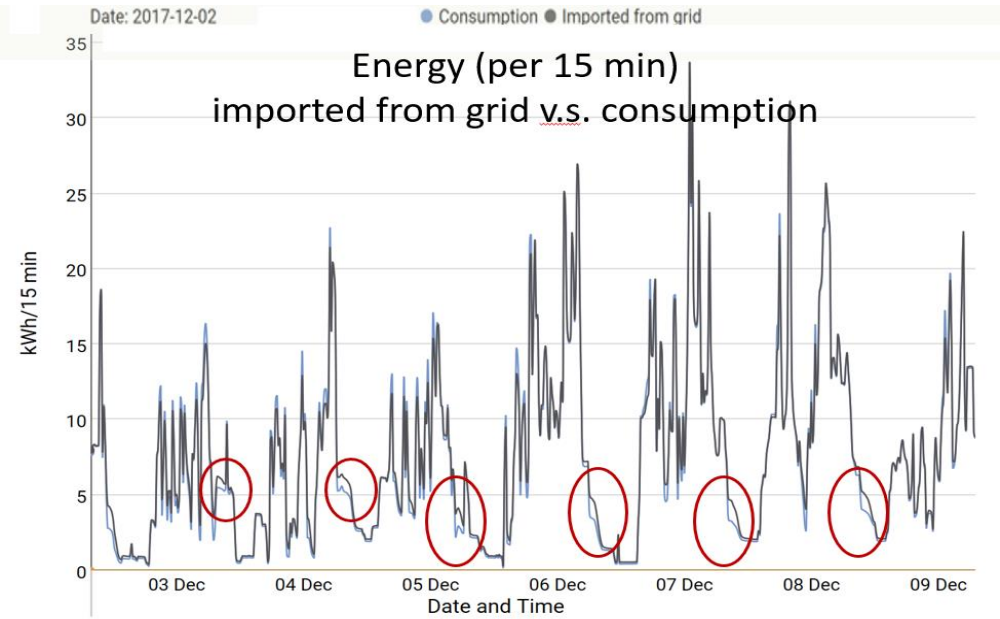

Figure 29: Energy (per 15 minute) comparison between the one imported from the grid and the consumption. The gap (labelled in red circle) between the energy imported from grid and consumption is the energy exchanged from/to the BESS





Discussion on the grid investment deferral

Figure 30 shows the EV charging electricity consumption at the Oslo Vulkan car parking garage over the last three years, which demonstrate a steady increase. The yearly electricity consumption increases from about 140,000 kWh in 2017, 350,000 kWh in 2018 and 710,000 kWh in 2019. It is worth noting that the Ferroamp BESS was deployed in February 2017, and there are about two months of missing data in 2018; accordingly, the actual electricity consumption in 2017 and 2018 should be greater than the numbers in Figure 30.

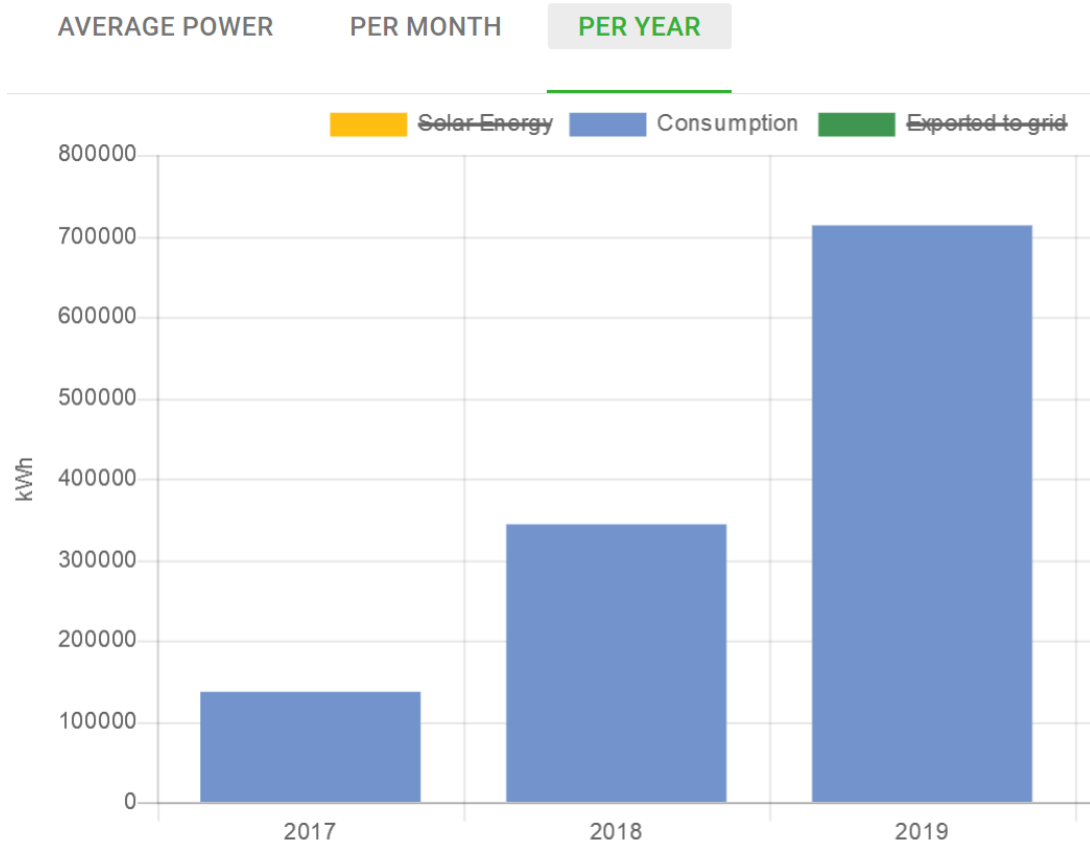

Figure 30: Energy Consumption per year

Instead of using the yearly energy consumption data, monthly energy consumption data (Figure 31 and Figure 32) and hourly energy consumption data (Figure 33) is used to analyse the trend of EV charging demand.

Figure 31 shows the monthly energy consumption for the EV charging (the blue bars) and the increasing trend of the energy consumption (the red line). A model is adopted to characterise the increasing demand of EV charging energy per month and the monthly energy consumption data is used to identify the parameters of the model. The identified model is:

$$E \text{ (in kWh)} = 1862 \times m + 6775 \tag{7}$$

where:

- m is the month number $m \in \{1, 2, 3, 4, \dots\}$ and 1 represents the month of March 2017;
- E in (kWh) is the modelled energy consumption from the model.

As suggested by the model, given in Figure 32, on average over the whole period, the energy demand increases by about 1862 kWh per month.



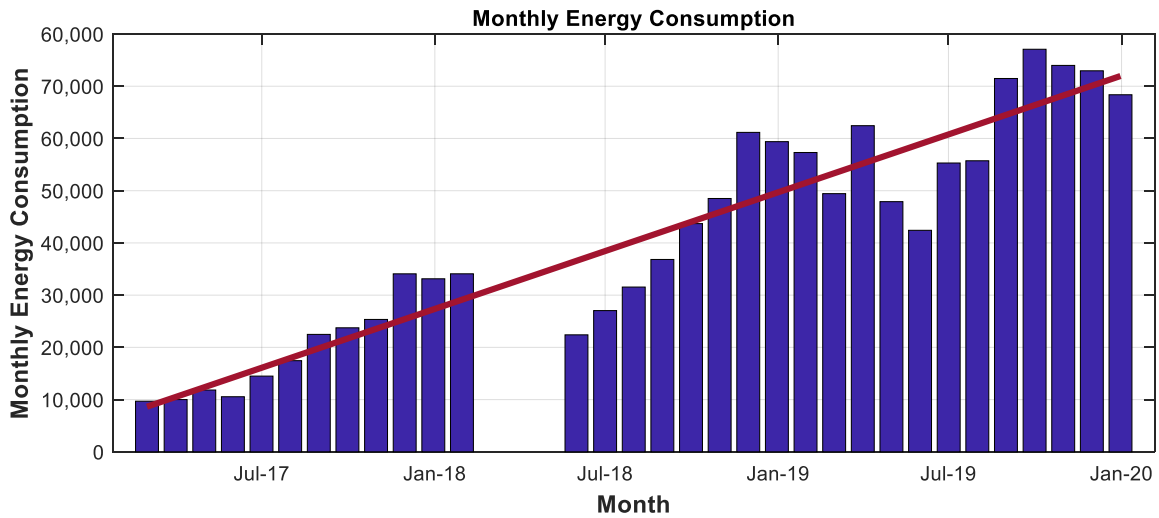

Figure 31: Energy Consumption per month (blue) and increasing trend (red) measured in the OP

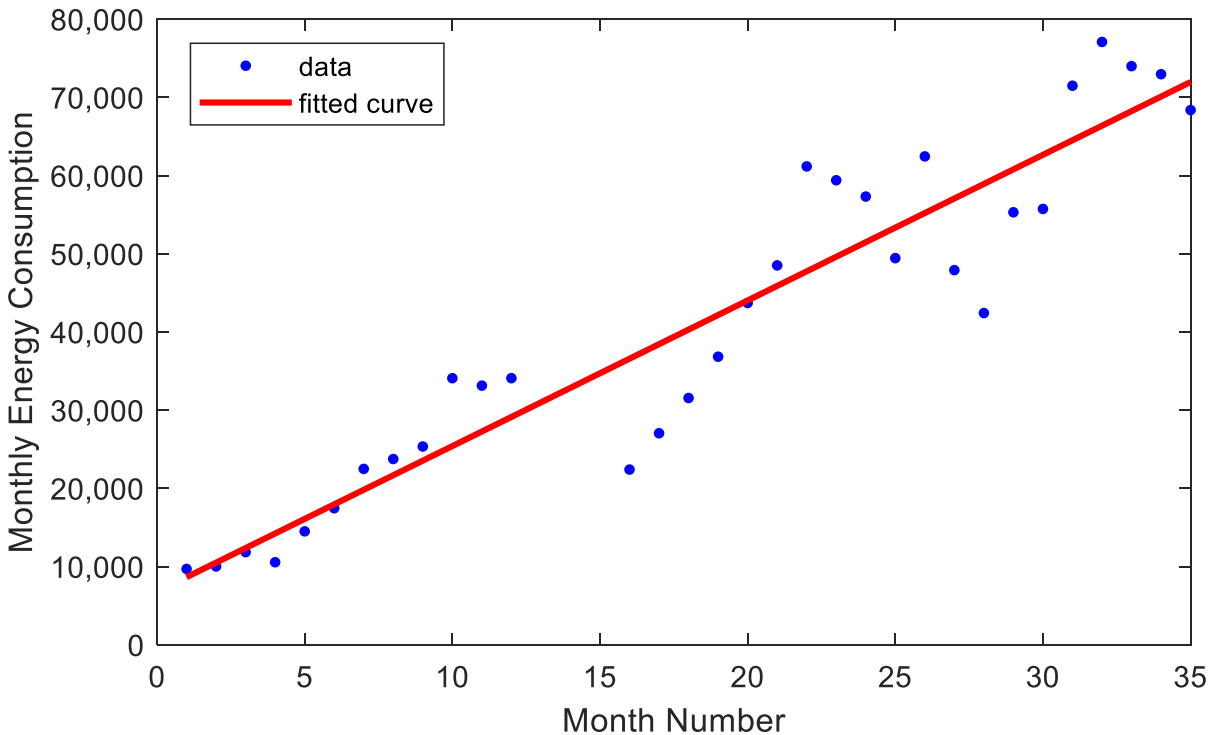

Figure 32: Model of the monthly energy consumption measured in the OP

The monthly energy consumption only gives a general picture of the increasing trend of the EV charging consumption, in terms of the averaged energy consumption. The electrical power (hourly energy consumption) gives a better representation of the EV charging demand, where the concern is the peak power demand of electricity for EV charging. Figure 33 shows the hourly power (kW) in the last three years (March 2017 to March 2020) and the forecasting of peak power demand. As discussed earlier, the highest demands are in the winter period, in particular in January (see also Figure 19).

As shown in Figure 33, from the historic power data describing the increasing power demand (the red solid line), a projection of future peak demand in the following 5 years (the dotted line) is made, on the assumption of a linear development.



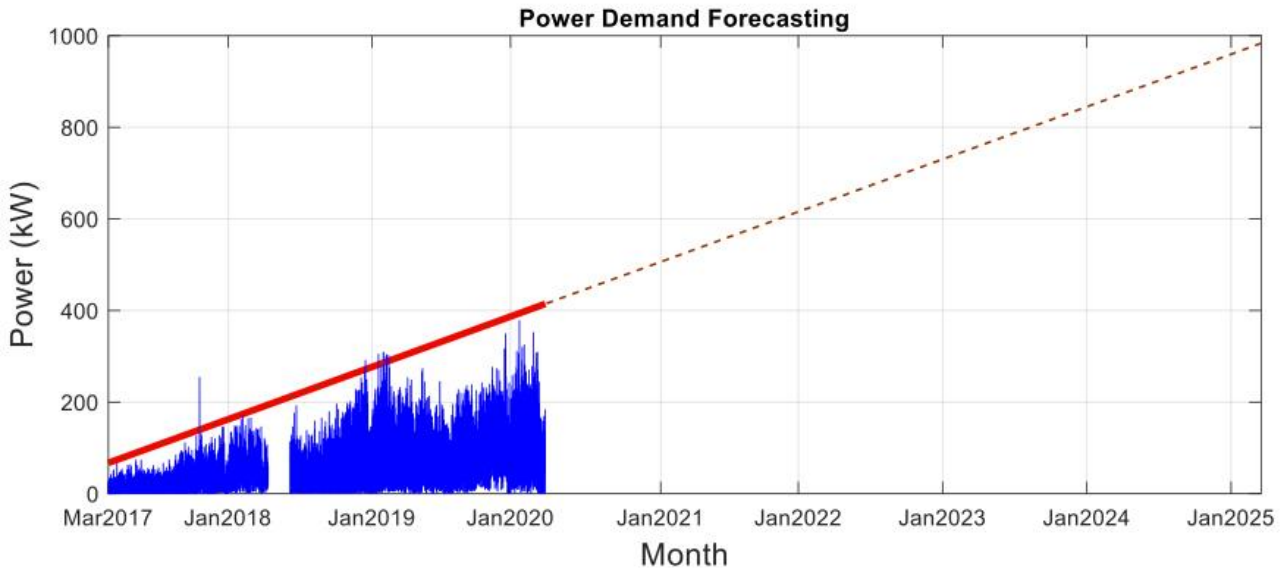

Figure 33: Hourly power demand and prediction for future power peak demand estimates

For the EV charging facility at the Vulkan car parking garage, the total amount of power supplied is restricted by the 1,250 A current limit of the main supply feeder. Therefore, the upper limit of the power demand can be calculated as:

$$P_{max} = \sqrt{3} \times V_L \times I_L \times p_f \quad (8)$$

where $V_L = 400$ V is the voltage of the distribution network, I_L is the current, p_f is the power factor.

A power factor of about 0.95 is typical for the type of EV charging loads. Therefore, by substituting the upper current limit $I_L = 1,250$ A, the upper limit of power supply to all the EV charging stations is ≈ 800 kW

From the projection of power demands in Figure 33 (with an assumption of a linear trend continuing), it can be seen that the peak power demand could be about 820 kW at around January 2024 and indeed could be just below 1,000 kW at about January 2025. Recalling the peak power demand measured of about 378 kW in January 2020, the peak power demand increases by about 12% of 1,000 kW (i.e. 120 kW per year) to reach 1,000 kW in January 2025. The latter could not be supplied without grid reinforcement, since it exceeds the capacity limit of 800 kW.

Comparing this to the estimated EV increase rate of 10% (as suggested by Figure 25, the increasing power demand of 12% is in line with the increasing penetration of EVs in Oslo. The BESS system, by carrying out peak shaving of 50 kW, is capable of postponing the need for system reinforcement based upon the projection shown in Figure 33.

Recalling the forecasts of the EV charging power demand illustrated in Figure 33, the threshold of 800 kW could be reached in the middle of 2023. Based on these projections, an investment will then need to be made to improve the grid's capability to supply more power to the EV car park charging stations.

At present, the BESS is only sized at 50.4 kWh and peak inverter power of 50 kW. In order to increase the deferral of grid investment beyond 2023, the capacity of the BESS (stationary battery and the inverter) has to be increased in order to provide the same potential effectiveness as the current BESS (or better).

It is obvious that the estimates of the grid investment deferral are based heavily on the forecasts of the future peak demands. In this report, a linear model is adopted to undertake forecasting, considering that only three years data are available for make the forecasts. Furthermore, changes of the EV policy in Oslo/Norway or some unexpected events may change the progress of EV penetration and the EV user behaviour significantly. An example is shown in Figure 34, where the EV charging demand has decreased significantly since the introduction of COVID-19 measures in Norway on 12 March 2020 (indicated by the red line). For comparison, the power consumption in the same period (1st March to 21st of March) in the last three years (2017, 2018 and 2019) are depicted in Figure 35. It can be seen that power consumption across each March has a similar pattern, although the level of the power increased from 2017 to 2019.

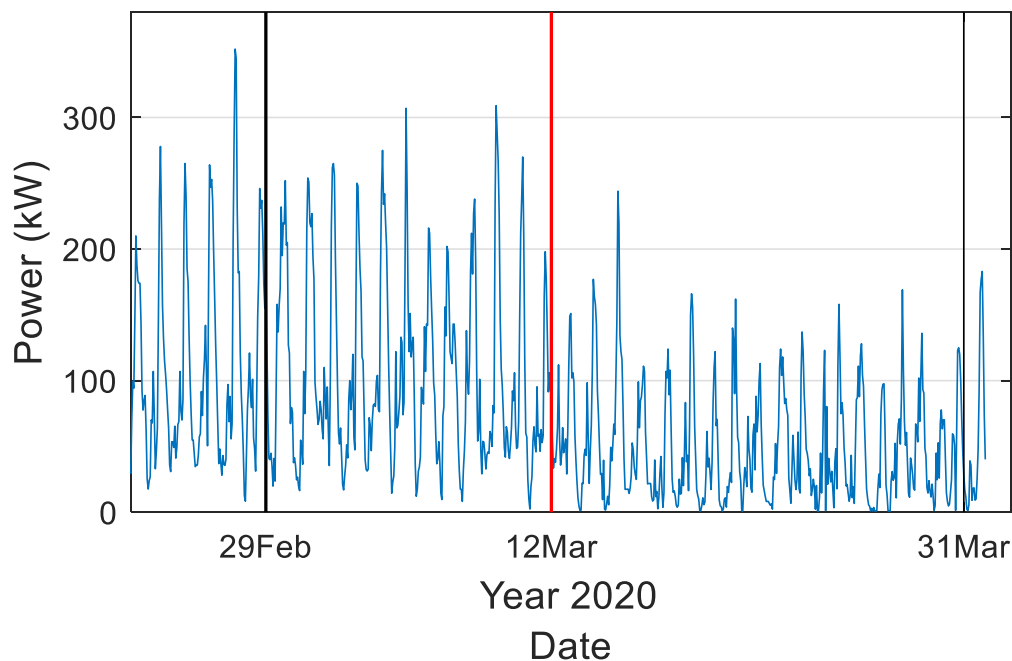

Figure 34: Demand decreases since the introduction of COVID-19 measures in Norway on 12 March 2020

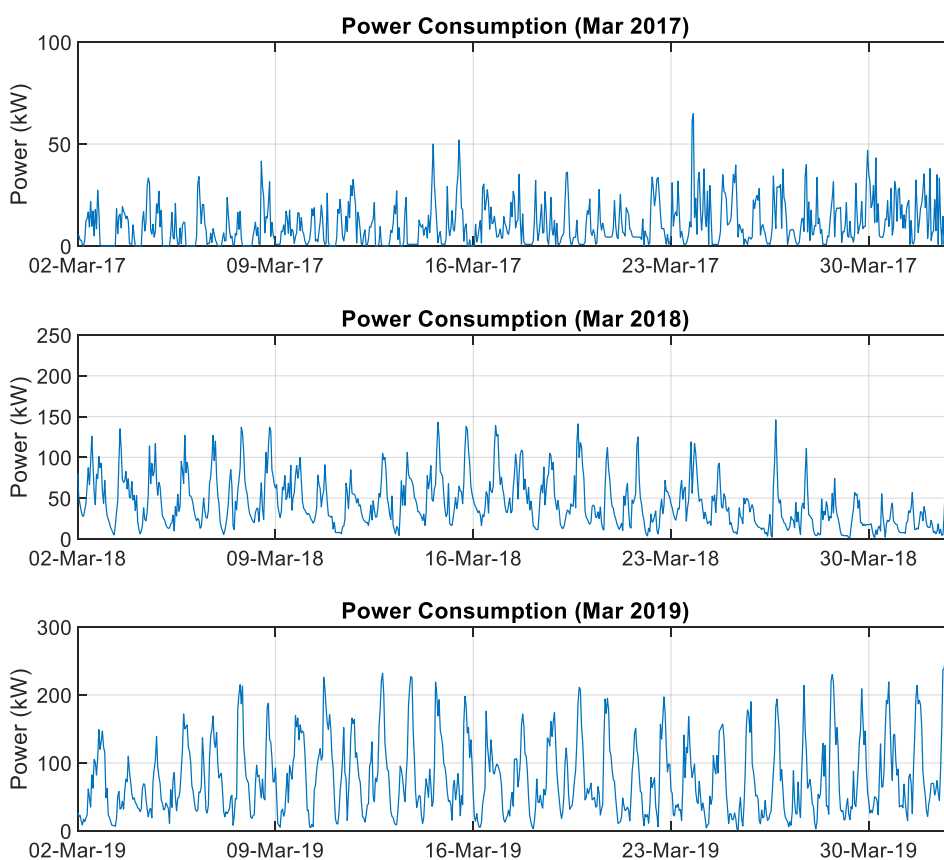

Figure 35: Demand corresponding to the same period in March for 2017, 2018 and 2019, respectively



4. Cost-Benefit Analysis

4.1. Generic Business Model

A cost-benefit analysis is the core of any business model and, in the context of the SEEV4-City project, this must be conducted for each EV4ES service to evaluate the profitability of the required investment. The structure of a generic business model for EV4ES is presented in Figure 36. According to the business model actually adopted (either the baseline, or the proposed one here for the future), there will be different stakeholders involved and different costs and benefits for each stakeholder.

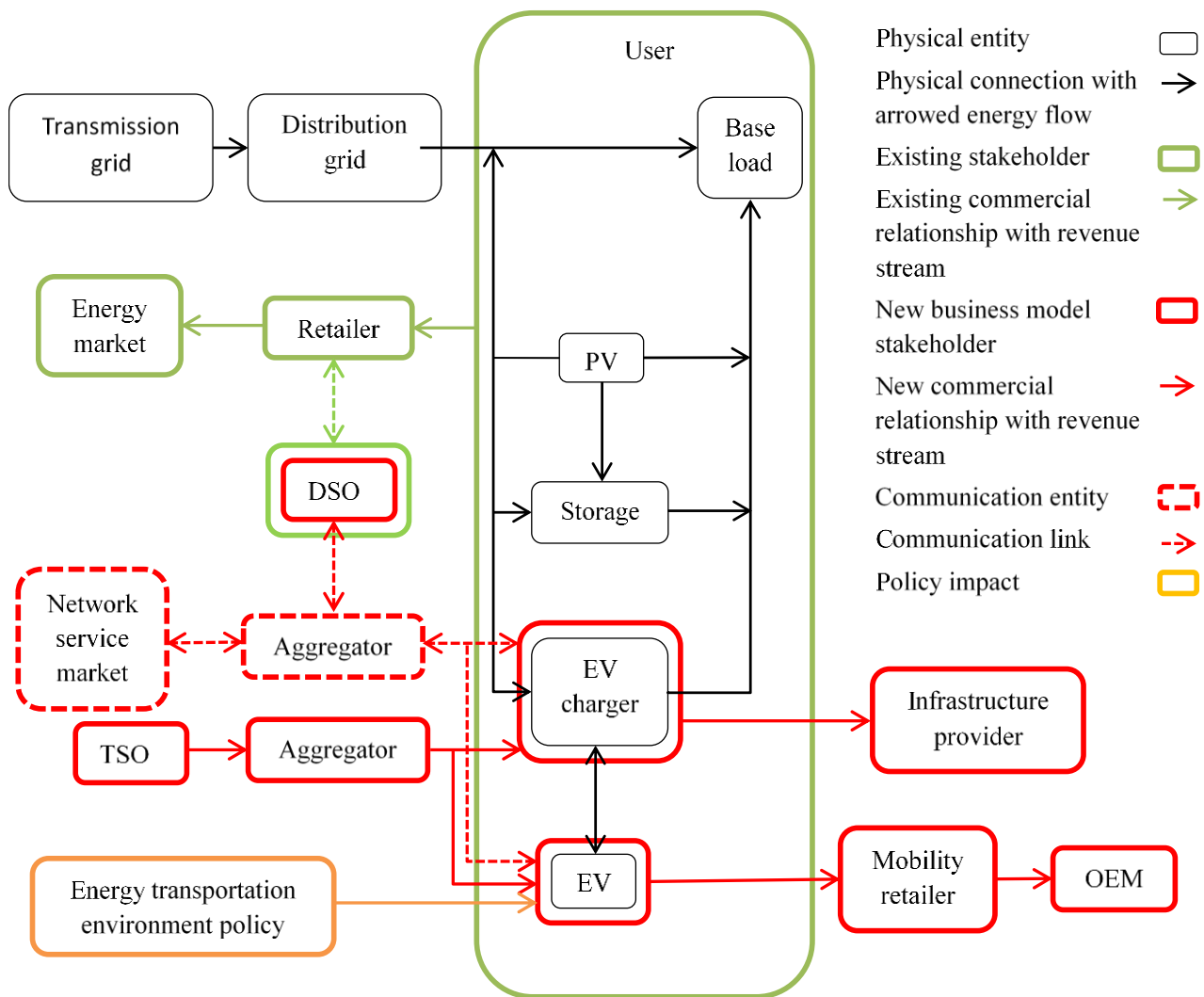

Figure 36: Generic business model structure for EV4ES

EV4ES and the associated business model can be tailored to favour different targets, following the reasoning illustrated in the 4 pillars shown in Figure 37. Currently, the priority objectives of the Oslo OP are the promotion of Green Transport Miles and decarbonisation of road transport (pillar 1), as well as cost savings for the EV infrastructure operator (and perhaps some of that is indirectly shared with the building owner). In the future, grid investment deferral (pillar 3) may well become much more prominent as a concern and priority also.

Accordingly, the stakeholders involved in the baseline case include the EV, the EVSE infrastructure provider (which here is the responsible party for billing for EV charging), the city council, the building owner (and also the car parking operator in principle at least, as they collect the parking-only fees).

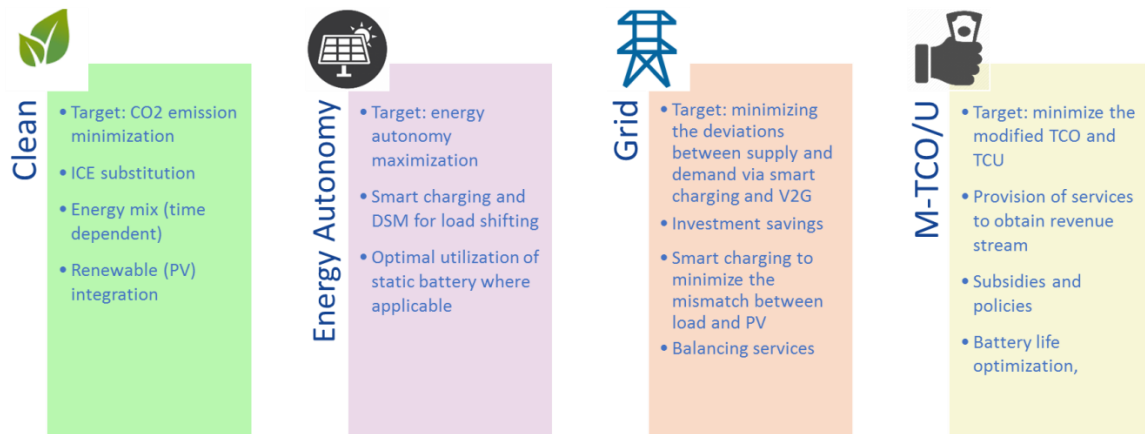

Figure 37: Business model pillars

4.2. Local/Regional and national subsidies and incentives

Apart from the above-mentioned cost scheme for parking and EV charging at the Vulkan parking garage, EVs currently also benefit (and may continue to do so after the end of 2021) from regional and national subsidies and incentives to make the Oslo model successful. The current Norwegian Parliament and Government has decided to keep the incentives for zero-emission cars until the end of 2021. The VAT exemption for zero-emission vehicles in Norway has been approved by the EFTA Surveillance Authority (ESA) until the end of 2020. After 2021, these incentives will be revised and adjusted in parallel with the market development [10] ²⁴.

Oslo City Council wants to encourage and cooperate with private sector players to increase the EV charging availability in Oslo in terms of density, quality, technological possibilities, user friendliness and user acceptance. This is to realise ambitious targets for greenhouse gas emissions reduction, as well as urban air pollution control.

In Oslo, several new measures are planned, including [11], [12]:

- A 'car-free city centre' (inner city);
- Residential parking zones with free parking for EVs (greater Oslo);
- Only zero-emission taxis from 2022 (across the whole city);
- New low-emission zones (greater Oslo);
- Congestion tax (none for EVs) across the whole city;
- Increased numbers of toll gates/ road throughout the city, with free passage for EVs;
- Free passage for EVs in tunnels;
- Free use of ferries for EVs;
- A 'fossil-free city' by 2024 (greater Oslo).

'Zero-emission' heavy-duty vehicles and 'zero-emission' taxis are also part of the new Oslo model's holistic approach to becoming fossil-free by 2024. «EL» licence plates were adopted since 1992 to make it easy to identify the vehicle as electric. Green public procurement, goods and services delivered by 'zero-emission' vehicles and good park and ride solutions, in combination with EVs, and increased use of intelligent traffic systems (ITS) and artificial intelligence (AI) to make EV use swift, efficient and user-friendly, are equally necessary for the Oslo model's success in the future.

Oslo City Council also intends to:

- Build new indoor parking garages for EVs;
- Construct new green mobility houses, including electric car sharing, bicycle hotels, electric bicycles, electric scooters, and other micro-mobility devices etc [12].

From March 2019, the City of Oslo started to charge a small user payment to finance the green mobility shift. The charging price is reasonable and low if compared to diesel and gasoline prices. It also prioritises residents and key sectors such as electric taxis and electric freight vehicles (the City of Oslo was a member of the

²⁴ <https://elbil.no/english/norwegian-ev-policy/>



FREVUE EU project consortium ²⁵). The City expects/anticipates that this revenue will be sufficient to finance the needed investments for additional charging infrastructure.

Incentives are important, but also more regulation on car usage is needed to make them work. Lemphers [13] concludes that:

It remains to be seen if Norway's EV policies will lead to broader decarbonization of the transportation sector. Between 1990 and 2017, emissions from road traffic rose by 22 per cent to 8.8 Mt CO₂eq, the third biggest source of emissions in the country (SSB 2018) (...) However, recent evidence suggest e-mobility policies are beginning to reverse the trend of growing pollution. Between 2016 and 2017, Norway experienced its largest ever drop in road transportation-related emissions, 9.5 per cent (SSB 2018). As the vehicle fleet turns over in Norway, emissions will likely continue this downward trend. Norway's average emissions for new passenger cars, measured in grams CO₂ per km, have decreased nearly 40 per cent between 2010 and 2016 (Johnsen 2017). If Norway can maintain the EV incentives until declining technology costs put EVs on par with fossil fuelled cars and if the country's efforts to electrify light and heavy-duty vehicles come to fruition, then decarbonization of the road transportation sector may be within reach. Ambitious policies like a country-wide ban on internal combustion vehicle sales by 2025 will make the goal even more possible (...) In the meantime, the demonstration effects made in the small Norwegian market are proving to other countries that decarbonizing transportation is possible [13, p. 11].

In Norway, full electric vehicles have currently (since 2001) a VAT (which would otherwise be 25%) exemption until the end of 2020. Full EVs (BEVs) are also exempt from purchase/import taxation (since 1990), and (since 1996) EV are not subject to any road / registration tax in Norway, subject to review and perhaps change after the end of 2021 [11].

In addition, BEVs were also given the permit to access to bus and taxi lanes in year 2003 for up to 1 hour per day. Across Norway, several bus corridors did then experience regular congestion during rush hour. The municipality of Oslo tackled this issue in 2017 by granting access to the bus lane on two specific corridors during rush hours only to electric cars with two or more persons on board [14], [15].

The exemption from VAT and registration taxes is only granted to BEVs. This is a key determinant for the lower purchase price of BEV models versus PHEVs. PHEVs are fairly popular in households with one car or taking frequent trips exceeding 100 km. In January 2017, the incentives for PHEVs were increased. In particular, the deduction on the total weight to be used for the determination of the taxation rate increased from 15% in 2015 to 26% in 2017. For large PHEVs, this change leads to registration tax cuts of NOK 16,000 – 80,000 (EUR 1,700 – 8,400) compared with similar ICE cars [15].

More details of savings in daily usage that EVs benefit from compared with ICEs in Norway and Oslo are presented in Table 15. There are around 4,000 standard and 80 fast charging points across Norway under the local and national EV infrastructure program since 2008. Differences in take-up however exist in the major Norwegian cities, due to for instance different parking fees and other incentives.

Table 15: Savings of EVs in daily usage compared with ICEs [15]

Vehicle usage cost	EVs	ICEs
National road and tunnel	Free access on toll roads (since 1997)	<ul style="list-style-type: none"> • In Oslo € 3.5 – 5 • National roads and tunnels up to € 20
Parking	Free parking (since 1999)	€ 2 – 5 per hour
Transport on ferries	Free transport on ferries (since 2009)	€ 12 – 24 each way

Furthermore, the following subsidies from Oslo's Climate and Environment fund could also potentially benefit the further uptake of EVs [12]:

²⁵ <https://frevue.eu/cities/oslo/>; <https://frevue.eu/resources/frevue-factsheet-fast-charging-infrastructure-electric-freight-oslo-stockholm-june-2017/>; <https://frevue.eu/wp-content/uploads/2019/04/FREVUE-Final-Report-v2.0.pdf> Here the City of Oslo cooperated with the local postal company Bring to introduce electric freight vehicles in its fleet and its distribution operations. This trial was accompanied by the implementation of technological solutions such as fast charging stations and novel ITS solutions for charging, loading and unloading slots pre-booking. The FREVUE activities in Oslo were used to assess the efficiency of electric vehicles in winter conditions and to benchmark the efficiency of electric vehicles in logistics against alternative fuelled and hybrid vehicles.





- Private companies, apartment complexes, shopping centres etc. can apply for subsidies to establish charging points;
- Up to €1,200 per charging point established and maximum 60% of the total cost can be subsidized;
- The Agency for Urban Environment of the Municipality of Oslo administers the applications.

Since home EV charging is cheaper and more convenient (for whom this is an option) than curb-side EV charging for both drivers and the city, Oslo has also developed a support scheme for home charging:

- Private housing associations and housing co-operatives can apply for a grant covering up to maximum 20% of all needed investments in charging infrastructure on private ground, up to a limit of NOK 1 million (~ \$117,613 USD).
- In 2018, more than 16,000 chargers in private housing co-operatives and associations were financed. This is a substantial figure compared to the deployment of then 600 new curb-side/on-street chargers owned and operated by the City on a yearly basis [12].

4.3. Base case for EV charging

As presented in the earlier sections, data regarding EV charging power demand, duration and charging initiation times are available from 02/01/2017 to 16/11/2017 (only). However, since the outlets can charge at four different charging speeds, there is no information regarding the charging power. This is particularly important as it serves as a base case for comparison against the proposed improvements. Therefore, the average charging powers are estimated by equation 9.

$$P^{EV} = \max \left(P^{charger}, \langle P^{EV} \rangle = \frac{E^{charged}}{t^{charged}} \right) \quad (9)$$

The charging power is estimated as the immediately higher charging rate compared to the result of the average.

Given the unique grid electricity-generation mix in Norway and also Oslo (at least 99% renewables) and the absence of distributed generation in the Operational Pilot boundary (i.e. the EV charging infrastructure, inverters and stationary battery DC-nanogrid), improvements in energy autonomy and CO₂ emission savings from smart energy management are not applicable for the Oslo OP. Therefore, the only CO₂ emission savings from ICE substitution are achievable and these have been calculated as **99.9 tons of CO₂** in the afore-mentioned period.

A calculation in accordance with SEEV4-City Methodology to show the monthly CO₂ saving arising from ICE vehicle substitution is given in Table 16. The figure for kWh charged by EVs at the Vulkan car parking garage represents the 2019 monthly average of the recorded figures. CO₂ emission due to Hydroelectric Generation is 20g/kWh. All EVs are considered to be BEVs for the purpose of the calculation (in line with SEEV4-City project rationale). The EV charging at the commencement of the Pilot was 10,000 kWh/month; at the end of the pilot monthly charging energy consumption averaged 59,469 kWh/month; this corresponds to an annual ZE km of 4,210,405. Based on EV charging energy consumption factors, the initial annual ZE km would have been 708,000 km. The target of 1.5 x would thus correspond to annual ZE km of 1,062,000 (see Table 16).

In the comparison by Hoekstra [6] on BEV versus Diesel cars, it is mentioned that the CO₂ mix of the grid includes energy use of the electricity network itself, pumping, trade and distribution losses. Charger losses are therefore already included and do not need to be addressed separately [16].





Table 16: Calculation of CO₂ savings from ICE substitution

ICE to BEV replacement	Value	Unit
Diesel Car Fuel emissions	217	g CO ₂ /km
Diesel Manufacturing emissions	27	g CO ₂ /km
Total Diesel emissions	244	g CO ₂ /km
EV energy use	5.9	km/kWh
Hydroelectric Generation emissions [9]	20	g/kWh
EV driving emissions	3.39	g CO ₂ /km
EV manufacturing emissions	40	g CO ₂ /km
Saving if EV batteries fully recycled	16	g CO ₂ /km
Total EV emissions	27.39	g CO ₂ /km
ICE to BEV savings	216.61	g CO ₂ /km
Average 2019 measured kWh charged	59,469	kWh/month
Km driven with charged kWh	350,867.1	km/month
Monthly ICE to BEV savings	76	ton CO ₂ /month
Annual ZE km	4,210,405	km/year
Annual CO ₂ savings	912	ton CO ₂ /year
CO ₂ related to use of battery: EV	14.3	ton CO ₂ /year

Figure 38 shows the top 20 Electrical Vehicles in Norway (Jan-Dec 2019). According to the percentage of the new sale cars in Norway for the year 2019, the market share for electric vehicles in the new car sale in Norway reached 42%, which shows a significant growth of 30% compared to 2018. The Tesla Model 3 was the most popular new passenger car with a market share of 21.9%. Besides this popular vehicle model, the market share of other EVs (both BEVs and PHEVs) combined was 42.39%.

Top 20 Electric Vehicles In Norway (Jan-Dec 2019)

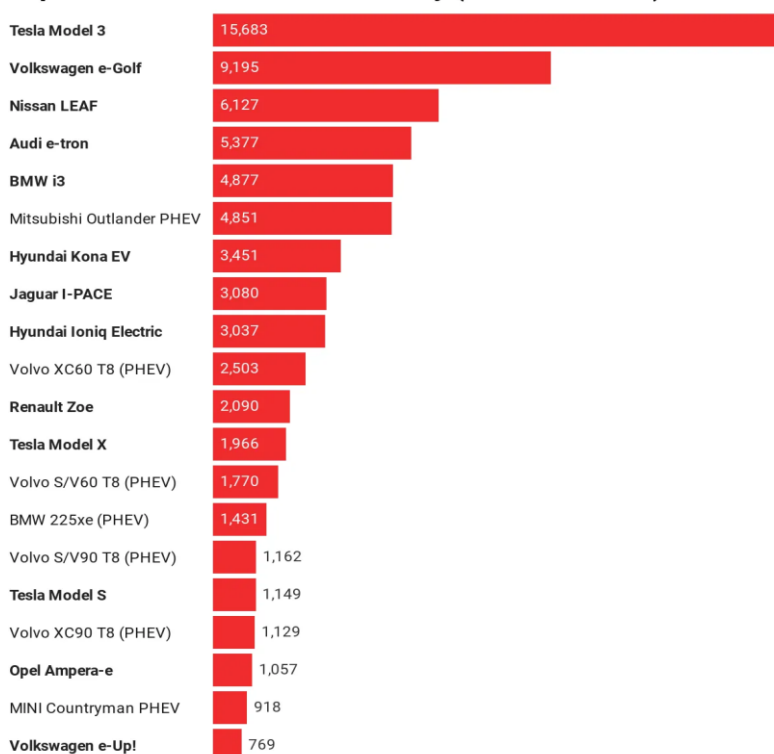

Chart: CleanTechnica - Created with Datawrapper

Figure 38: Top 20 Electrical Vehicles in Norway (Jan-Dec 2019) [17]





Since we do not fully know the exact efficiency of electrical vehicles, or indeed ICEs, and in the case of this Oslo operational OP do not know the identity/ model of the EVs charging, one has to go by a rule of thumb based on average assumptions of the BEV/ PHEV fleet in Oslo (or if that is not known Norway nationally), and near realistic approximations of drive and range (km) efficiency with kW/h electricity consumption for EVs, such as the ‘Electric car range and efficiency table (NEDC)’ [6] or eventually the new Worldwide harmonized Light vehicles Test Procedures (WLTP) is a test cycle which should be fully updated during 2020. While WLTP will measure CO₂ emissions, NO_x will be measured by the Particulate Real Drive Emissions (RDE) [18].

Based on the specification of these popular EV models, the battery power consumption efficiencies of these vehicles [19] [20] are listed in Table 17. An average electrical power consumption efficiency of 5.1 km/kWh is used to complete the estimation. Overall, the weighted electrical power consumption efficiency \bar{E} is estimated as

$$\bar{E} = \sum(\text{Market Share}) \times \text{Efficiency} \tag{10}$$

which yields the weighted efficiency of 5.9 km/kWh.

Table 17: Energy efficiency of some popular EVs sold in Norway during 2019

Vehicle Model	Market Share (%)	Efficiency (km/kWh)	Efficiency (kWh/100km)
Tesla Model 3	21.90%	6.25	16 *1
Volkswagen e-Golf	12.84%	7.50	13.3 *2
Nissan LEAF	8.55%	6.67	15.0 *3
Audi e-tron	7.51%	4.35	23.0 *4
BWM i3	6.81%	7.25	13.8 *5
Other {includes PHEVs and small as well as large BEVs	42.39%	5.1	19.6*6

Sources:

*1 https://en.wikipedia.org/wiki/Tesla_Model_3

*2 <https://www.nextgreencar.com/cost-calculators/vw/e-golf/>

*3 <https://www.nextgreencar.com/content/NGC-Fuel-Cost-Calculator-Methodology-2016-v2-0.pdf>

*4 <https://www.audi-mediacycenter.com/en/audi-e-tron-75>

*5 <https://www.nextgreencar.com/cost-calculators/bmw/i3/>

*6 <https://www.co2emissiefactoren.nl/lijt-emissiefactoren/>

Hoekstra argues and calculates that:

Greenhouse gas (GHG) emission reductions possible with battery electric vehicles (BEVs) are underestimated in the scientific literature. The following causes are identified and illustrated: overestimating battery manufacturing, underestimating battery lifetime, assuming an unchanged electricity mix over the lifetime of the BEV, using unrealistic tests for energy use, excluding fuel production emissions, and lack of system thinking. In an example calculation, BEVs reduce emissions from 244 to 98 g/km. In a fully renewable system, BEV emission could decrease to 10 g/km [6, p.1412].

4.4. Cost-benefit analysis

Cost benefit analysis is the core of any business model. In the context of SEEV4-City project this will be presented for each EV4ES service to evaluate the profitability of the associated investment, and therefore to provide smart energy management plan to other business with similar scales.

The limited achieved savings is due to multiple reasons:

- Limited wholesale market price difference;
- V2G/V2B is currently not implemented, therefore energy arbitrage is limited.

Other costs (such as electricity transmission and distribution costs) are not known; some of those could also be saved by smart charging.





4.4.1. Tariff Analysis

In Norway, electricity prices now consist of 3 parts:

- The basic power cost in Øre/kWh;
- A contribution towards maintenance and development of the transmission and distribution systems known as the 'Grid Rent';
- An element of taxation in Øre/kWh.

VAT ('MVA') is charged in addition on the sum of the above.

In [21] it is possible to find tables that show the electricity prices for various user classes including household, service companies and manufacturing industries, as shown in Table 18.

Table 18: Electricity prices in the end-user market, quarterly (Øre/kWh)

	1 st quarter 2019	Change in per cent	
	Øre/kWh	Last 3 months	Last 12 months
Households. Total price of electricity, grid rent and taxes	124.3	0.7	16.8
Electricity price	55.2	0.7	29.9
Grid rent	30.4	3.4	9
Taxes	38.7	-1.3	7.5
Households. Electricity price by type of contract. Exclusive taxes			
New fixed-price contracts-1 year or less ¹	46	-10.3	39.8
New fixed-price contracts-1 year or more ¹	42.3	-2.8	53.3
All other fixed-price contracts	34.6	1.2	13.8
Contracts tied to spot price	53.1	0	25.8
Variable price (not tied to spot price)	63.6	3.9	43.2
Business activity. Electricity price. Exclusive taxes			
Services	51.1	0.8	31
Manufacturing excl. energy-intensive manufacturing	50.3	1.8	30.3
Manufacturing energy-intensive manufacturing	32.5	2.2	3.5
¹ New fixed-price contracts are entered during the measuring period, and older fixed-price contracts are entered earlier. Source: Statistics Norway [21]			





The Vulkan car parking garage and EV charging stations would count as a service industry. The same source [21] provides a more detailed overview of pricing, as shown in Table 19.

Table 19: Electricity prices in the end-user market, quarterly. Exclusive taxes. Øre/kWh

	1 st quarter 2019	Change in per cent		4 th quarter 2018	1 st quarter 2018	Breakdown of electricity sales by volume. Percent
		Last 3 mos.	Last 12 mos.			
Households	55.2	0.7	29.9	54.8	42.5	100
New fixed-price contracts, 1-year or less, households ¹	46	-10.3	39.8	51.3	32.9	0.4
New fixed-price contracts, more than 1-year, households ¹	42.3	-2.8	53.3	43.5	27.6	0.1
Older fixed-price contracts, households	34.6	1.2	13.8	34.2	30.4	1.5
Contracts tied to spot price, households	53.1	0	25.8	53.1	42.2	74.7
Variable price contracts, households	63.6	3.9	43.2	61.2	44.4	23.3
SERVICES	51.1	0.8	31	50.7	39	100
New fixed-price contracts, services ¹	33.9	-16.5	18.1	40.6	28.7	1.5
Older fixed-price contracts, services ¹	40.4	18.8	25.9	34	32.1	3.5
Contracts tied to spot price, services	51.6	-0.2	30.6	51.7	39.5	90.8
Variable price contracts, services	56.6	-1.6	34.1	57.5	42.2	4.2
MANUFACTURING EXCL. ENERGY-INTENSIVE MANUFACTURING	50.3	1.8	30.3	49.4	38.6	100
New fixed-price contracts, manufacturing excl. energy-intensive manufacturing ¹	37.1	-17.9	21.2	45.2	30.6	0.6
Older fixed-price contracts, manufacturing excl. energy-intensive manufacturing ¹	33.5	5.3	14.3	31.8	29.3	5.9
Contracts tied to spot price, manufacturing excl. energy-intensive manufacturing	51.3	2	31.5	50.3	39	90.5
Variable price contracts, manufacturing excl. energy-intensive manufacturing	56.4	1.4	32.4	55.6	42.6	2.9
ENERGY-INTENSIVE MANUFACTURING²	32.5	2.2	3.5	31.8	31.4	100
Contracts tied to spot price, energy-intensive manufacturing	45.8	-0.2	24.8	45.9	36.7	:

¹New fixed-price contracts are entered during the measuring period, and older fixed-price contracts are entered earlier.
²Average for all types of contracts, incl. new fixed-price contracts and variable price (not tied to spot price). The pulp and paper industry is included in energy-intensive manufacturing.
 Source: Statistics Norway [21]

The source above only details power taxes and Grid Rent for a domestic situation. Where one is dealing with a service business, the tax situation is stated in [5]. The tax rate will be 15.83 Øre per kWh.

Electrical power tax

A tax is levied on all electric power supplied in Norway, including power supplied free of charge and power distribution companies or generators use for internal purposes, see Table 20.

Table 20: Rate for 2019

Tax	15.83 Øre per kWh
Reduced tax	0.50 Øre per kWh





Among other things, the normal rate covers power supplied to households, non-industrial commercial activity and administrative buildings in the industrial manufacturing sector.

A reduced tax rate applies to electrical power that is supplied:

- To the industrial manufacturing and mining sectors;
- For use in the generation of district heating;
- To all commercial activity in Finnmark and certain municipalities in Nord-Troms;
- To data centres with an output in excess of 0.5 MW;
- To commercial vessels.

Exemptions from the electrical power tax

Exemptions apply for power supplied to:

- Certain power-intensive processes;
- Commercial greenhouses;
- Propulsion of means of transport that run on rails;
- Households and public administration in Finnmark, and certain municipalities in Nord-Troms.

The Grid Rental for commercial service businesses depends upon the area of Norway the service company is involved with in drawing their electricity for locational activities [22], as given in Table 21.

Table 21: Net rental statistics for business customers

County Name	Nettstasjon (Nivå 4) NOK/kW/år *	Lavspennnett (Nivå 5) NOK//kW/år **	Lavspennnett (Nivå 5) Øre/kWh ***
Østfold	724	903	22,6
Akershus	641	768	19,2
Oslo	589	442	11,0
Hedmark	845	875	21,9
Oppland	743	939	23,5
Buskerud	710	896	22,4
Vestfold	795	1128	28,2
Telemark	846	1145	28,6
Aust-Agder	722	960	24,0
Vest-Agder	722	960	24,0
Rogaland	755	876	21,9
Hordaland	1001	1263	31,6
Sogn og Fjordane	973	1343	33,6
Møre og Romsdal	715	1104	27,6
Sør-Trøndelag	800	1100	27,5
Nord-Trøndelag	831	1089	27,2
Nordland	890	1210	30,2
Troms	739	925	23,1
Finnmark	848	1160	29,0
Landsgjennomsnitt	820	1069	26,7

*The grid rent is converted, and applies to customers with a maximum of 400 kW and 1.6 GWh.
 ** Net rent converted to NOK / kW / year for a business customer with a power output of 40 kW and 160 MWh / year
 *** The grid rent is converted to Øre / kWh for a commercial customer with power output of 40 kW and 160 MWh / year

A chart of the breakdown of household electricity prices from 2012 to 2018, and the variation in industrial electricity prices from 1995 onwards are shown in Figure 39 and Figure 40, respectively.



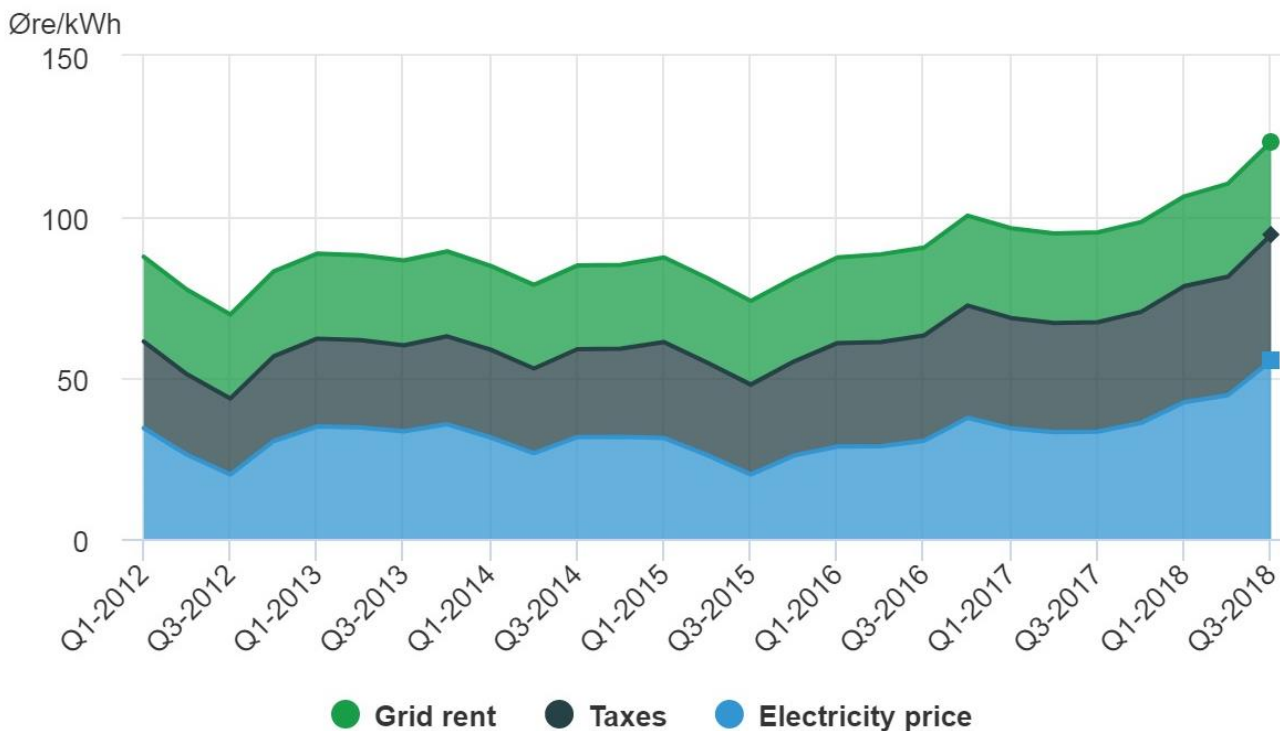

Figure 39: The breakdown of household electricity prices, grid rent and taxes for household [23]

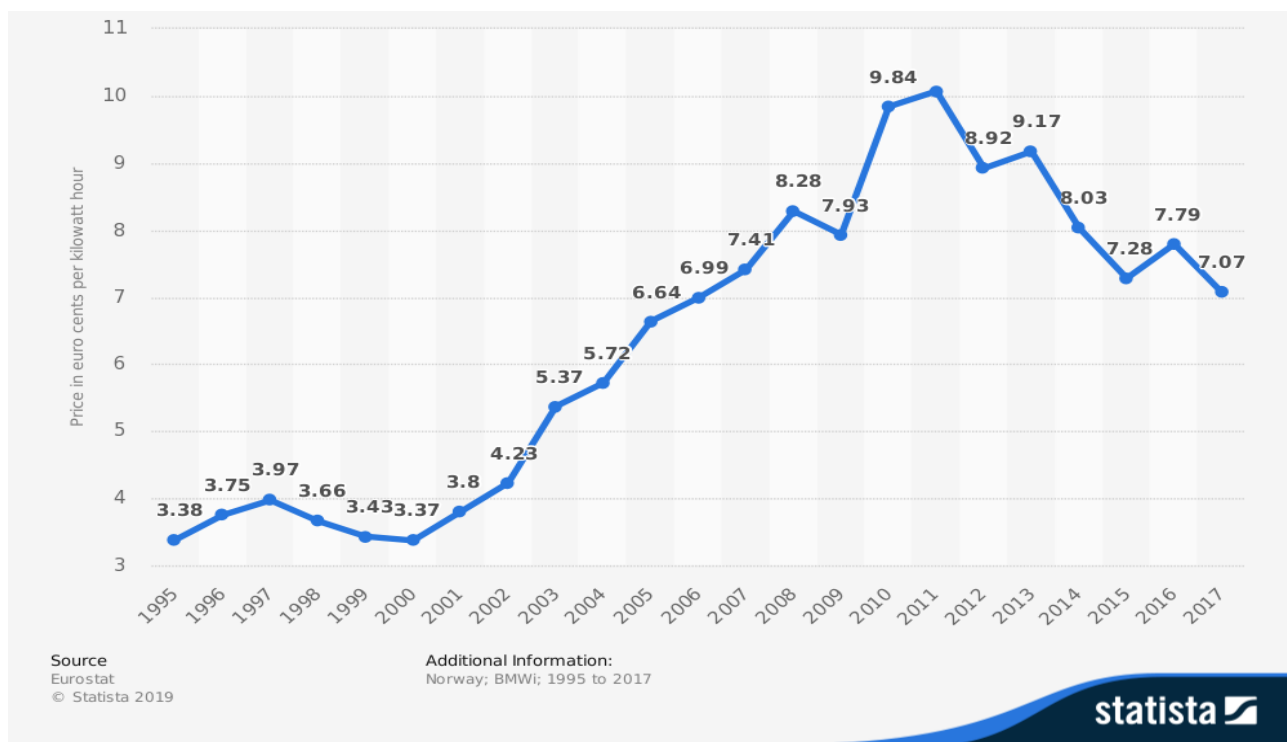

Figure 40: The variation in prices of electricity for industrial use from 1995 to 2017 [24]





A. Basic power cost

The Oslo car park is a service industry, for which the 3rd quarter 2019 basic power cost was 37.9 Øre/kWh [21]. Within the overall category of Services (37.9 Øre/kWh), there are sub divisions depending on the type of contract actually existing (all in Øre/kWh) [21]:

- Services overall: 37.9
- New fixed-price contracts, services: 36.0
- Older fixed-price contracts, services1: 35.0
- Contracts tied to spot price, services: 37.9
- Variable price contracts, services: 43.9

During 2019, the system of electricity charging in Norway and Oslo appears to have altered, with a lower per-unit energy cost, but extra grid costs. In addition, there is a fixed connection charge of 39.20 NOK/month, known as the 'Fastbelop'.

B. Grid Rent

The costs associated with the development and operation of the electricity grid are charged to the part of the electricity bill called 'the grid rent'. Charges include:

- a) A fixed monthly fee ('Fastledd');
- b) An energy link ('Energiledd') that varies depending on whether it is winter or summer;
- c) A power link ('Effektledd') with three different prices depending on the season.

The fixed monthly fee (a) is straightforward, amounting to NOK 340/month per facility.

The energy link (b) is a fee paid per consumed kWh. In the five winter months from November to March, a fee of 7 Øre/kWh is paid, while in the summer months of April to September a fee of 3.9 Øre/kWh is paid.

The power link charge (c) is more complicated. The power link is stated to be a price paid per kW / month. It is NOK 150/kW in the winter months December to February, NOK 80/kW in March and November, and NOK 23/kW in the period from April to October. The power link is calculated according to the highest energy consumption during one hour per month based on the hour of highest power consumption during the invoice month. This means that the one hour when the most electricity is used is the hour that determines how much power applies for the whole of the month. This is the point of power pricing. The grid companies have to build the electricity grid to withstand the maximum load, and if customers are better at distributing electricity consumption outwards so that the peaks are not so high, then investment costs will not be higher than necessary [25].

C. Forbruksavgift

A tax 'Forbruksavgift' is levied on all electric power supplied in Norway, including power supplied free of charge and power distribution companies or generators use for internal purposes. Where one is dealing with a service business the tax rate will be 15.83 Øre per kWh [5]. Amongst other things, this rate covers the power supplied to households, non-industrial commercial activity and administrative buildings in the industrial manufacturing sector.

Fortum does not have a list of power costs per kWh from month to month (Fortum Charge & Drive, communication in mid-January 2020). We therefore take recourse to 2 specimen bills provided by Fortum Charge & Drive as examples of the respective costing systems adopted.

Considering the Fortum bill for Feb 2019 shown in Figure 41, there is a simple energy charge 'forbruk' of Øre 56.21/kWh between 1/2/19 and 18/2/19, with a lower charge of Øre 50.02 applying between 18/2/19 and 01/3/19. Energy used in the month totalled 59,851 kWh. A fixed connection charge 'fastbelop' of NOK 39.20/month applies and VAT is applied to the total.





Fakturadetaljer

Grunnet overgang til Elhub 18.02.2019 fremkommer det flere fakturalinjer for perioden på strømregningen. Se www.fortum.no/elhub for mer detaljert informasjon eller ta kontakt med Fortums kundesenter.

Din strømvtales er CO2FRI næring, leverandør er Fortum Markets AS.

Strøm	Periode	Pris	Mengde	Sum Kr
CO2FRI forbruk	01.02.19 - 18.02.19	56,21 øre/kWh	39 322,00 kWh	22 104,54
CO2FRI forbruk	18.02.19 - 01.03.19	50,02 øre/kWh	20 528,70 kWh	10 268,48
CO2FRI fastbeløp	18.02.19 - 01.03.19	39,20 Kr/mnd	0,39 Mnd	15,40
CO2FRI fastbeløp	01.03.19 - 01.04.19	39,20 Kr/mnd	1,00 Mnd	39,20
CO2FRI fastbeløp	01.02.19 - 18.02.19	39,20 Kr/mnd	0,61 Mnd	23,80
CO2FRI fastbeløp	01.02.19 - 01.03.19	39,20 Kr/mnd	- 1,00 Mnd	- 39,20

Sum Strøm **32 412,22**

Sum eks. MVA Kr 32 412,23
MVA Kr 8 103,05

Delsum **Kr 40 515,28**

Målerstander

Målerstander registrert på Maridalsveien 15 U 2, målernummer **7359992899885795**.

Forventet årsforbruk på denne adressen er 308848 kWh.

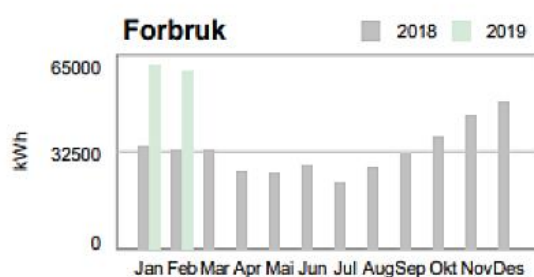

Avlest dato	Avleser	Målerstand	Forbruk
01.02.2019	Fjernavlest	361214.00	
04.02.2019	Fjernavlest	368778.00	7564
11.02.2019	Fjernavlest	386473.00	17695
18.02.2019	Timeverdier fra Elhub	400536.00	14063
25.02.2019	Timeverdier fra Elhub	413357.00	12821
01.03.2019	Timeverdier fra Elhub	421065.20	7708
Sum forbruk			59851

Figure 41: Fortum bill, February 2019

The second bill, shown in Figure 42, is a bit more complex, using as it does a new system of charging aimed at penalising peak demand:

Strømlleverandør

Fortum Markets AS

Om Fortum

Fortums mål er å være ledende innen ren energi. Derfor tilbyr vi blant annet strømvtales med opprinnelsesgarantier og ledetjenester for elbil. Les mer på fortum.no

Vilkår for betalingsutsettelse

For betalingsutsettelse eller deling av faktura påløper utsettelsesrente på 4,75% p.a. og et gebyr på kr 79. Dersom du har strømvtales Fortum Enkel er tjenesten rente- og gebyrfri.

Spørsmål?

Lurer du på noe angående din faktura, kan du kontakte oss på telefon 21496910 eller e-post: kundeservice@fortum.com. Er det uenighet som ikke kan løses, har du mulighet til å klage til Elklagene mda: www.elklagenemda.no For råd om energisparing og energiomlegging, kontakt Enova gratis på tlf 800 49 003.

Ved skifte av strømlleverandør skal navn, fødselsdato, målepunkt-ID og anleggsadresse oppgis til ny strømlleverandør. På Forbrukerrådets internettsider, strompris.no, kan man sammenligne priser.

eFaktura - enklere for deg, bedre for miljøet

Når du betaler din faktura i nettbanken kan du velge å opprette eFaktura. Din faktura sendes da direkte til din nettbank. Du får fakturaen ferdig utfylt og trenger kun å godkjenne betalingen - enklere for deg, bedre for miljøet.





Fakturadetaljer

Din strømavtale er CO2FRI næring, leverandør er Fortum Markets AS.

Strøm	Periode	Pris	Mengde	Sum Kr
CO2FRI forbruk	01.09.19 - 01.10.19	37,98 øre/kWh	55 830,90 kWh	21 204,94
CO2FRI fastbeløp	01.10.19 - 01.11.19	39,20 Kr/mnd	1,00 Mnd	39,20
Sum Strøm				21 244,14

Nett	Periode	Pris	Mengde	Sum Kr
Energiledd	01.09.19 - 30.09.19	3,90 øre/kWh	55 831,03 kWh	2 177,41
Fastledd	01.09.19 - 30.09.19	340,00 Kr/mnd	1,00 Mnd	340,00
Forbruksavgift	01.09.19 - 30.09.19	15,83 øre/kWh	55 830,89 kWh	8 838,03
Effektledd	01.09.19 - 30.09.19	23,00 Kr/kW	238,80 kW	5 492,40
Sum Nett				16 847,84

Sum eks. MVA	Kr	38 091,98
MVA	Kr	9 522,99

Delsum **Kr 47 614,97**

Målerstander

Målerstander registrert på Maridalsveien 15 U 2, målernummer 7359992899885795.

Forventet årsforbruk på denne adressen er 616082 kWh.

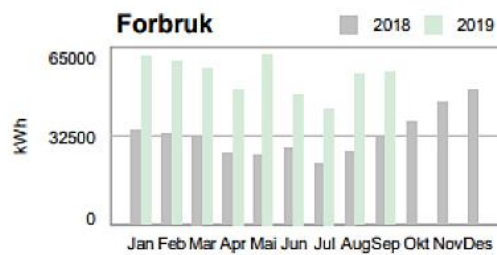

Avlest dato	Avleser	Målerstand	Forbruk
01.09.2019	Timeverdier fra Elhub	737009.00	
02.09.2019	Timeverdier fra Elhub	739204.00	2195
09.09.2019	Timeverdier fra Elhub	752776.90	13573
16.09.2019	Timeverdier fra Elhub	766163.20	13386
23.09.2019	Timeverdier fra Elhub	777998.80	11836
30.09.2019	Timeverdier fra Elhub	790857.70	12859
01.10.2019	Timeverdier fra Elhub	792840.40	1983
Sum forbruk			55831

Figure 42: Fortum bill, September/October 2019

Here we have a basic energy charge 'forbruk' of Øre 37.98/kWh. Energy used was 55,831 kWh in the month. There is a fixed connection charge 'fastbeløp' of NOK 39.20/month as before. In addition, we have the energy link fee (b) 3.9 Øre/ kWh ('Energiledd'); the fixed connection charge (a) ('Fastledd') of NOK 340/month; the power link charge (c) ('Effektledd') at the April to October rate of NOK 23/kW (based on a maximum measured hourly power of 238.80 kW) and the energy tax ('Forbruksavgift') at Øre 15.83/kWh. VAT at 25% is charged on the total (NOK 38,091.98).

The overall result of the changes from the February bill to the September bill is a price increase for Fortum. In February 2019, the usage was 59,851 kWh for which NOK 40,515.28 was paid. In September 2019, the usage was 55,831 kWh for which NOK 47,614.97 was paid.

It is evident that if the BESS is used at full power rating (50 kW), it will be able to minimise the hourly maximum load for the car parking garage, thus saving some of the peak demand charge (c) ('Effektledd'). The peak demand in January 2020 was 378 kW before any reduction by the BESS system (which was not in fact achieved). Given that the peak demand charge in January is 150 Kr/kW, the reduction in the peak demand by 50 kW via application of BESS output would have given rise to a saving in the charge for 'Effektledd' of $150 \times 50 = 7,500$ NOK for the month.

Grid Considerations

An overview of the Norwegian Grid is provided in [26]. Parts of the Norwegian power grid are aging, and this requires large investments. The grid companies have to replace power lines that are approaching the end of their lifespan and begin to fail, as well as ensuring the capacity to receive electricity from new wind power and distributed generation. Large parts of the net are due for replacement.

Strømlleverandør
Fortum Markets AS

Om Fortum
Fortums mål er å være ledende innen ren energi. Derfor tilbyr vi blant annet strømavtaler med opprinnelsesgarantier og ladetjenester for elbil. Les mer på fortum.no

Vilkår for betalingsutsettelse
For betalingsutsettelse eller deling av faktura påløper utsettelsesrente på 4,75% p.a. og et gebyr på kr 79. Dersom du har strømavtalen Fortum Enkel er tjenesten rente- og gebyrfr.

Spørsmål?
Lurer du på noe angående din faktura, kan du kontakte oss på telefon 21496910 eller e-post: kundeservice@fortum.com. Er det uenighet som ikke kan løses, har du mulighet til å klage til Elklagenemda: www.elklagenemda.no. For råd om energisparing og energiomlegging, kontakt Enova gratis på tlf 800 49 003.

Ved skifte av strømlleverandør skal navn, fødselsdato, målepunkt-ID og anleggsadresse oppgis til ny strømlleverandør. På Forbrukerrådets nettsider, strompris.no, kan man sammenligne priser.

Netteier
Hafslund Nett AS
Orgnr. NO980489698MVA
Tlfnr. 21490300



The report showed that some power lines and cables were built as early as the 1920s, but some of these are probably in reserve and are not in daily use. According to the Norwegian Water Resources and Energy Directorate (NVE), the bulk of the local power distribution network was built between 1975 and 2000, with a peak around 1990. The larger power lines in the regional and national grid were largely built between 1960 and 1990.

A recent overview shows that Statnett and the local and regional grid companies are planning to invest NOK 140 billion in the power system over the next ten years. This can lead to higher network rent for power consumers.

The difference between the grid companies is great, but in some areas, households must expect to pay several thousand Norwegian Kroner (NOK) extra in grid rent per year. The Norwegian Water Resources and Energy Directorate regularly collects data from the grid companies over planned investments, to find out where the challenges lie, and a recent report is now available. The report estimated that about one-third of the local distribution network's airlines are over 40 years old and are starting to be ready for replacement. This is how the planned investments are distributed over the next decade, according to the NVE's Statnett's investments in the main grid, the "main roads" of 420,000 V, as well as new foreign cables to Germany and the UK: NOK 50-70 billion. Regional network investments, lines of 66,000 and 122,000 V: NOK 22 billion. Distribution network, local lines of less than 22,000 V: NOK 48 billion. Smart electricity meters or AMS: NOK 10 billion.

The network companies intend to invest a lot of money to upgrade the power grid. The peak is expected around 2020 and 2021, due to Statnett's construction of new international foreign cables to Germany and the UK.

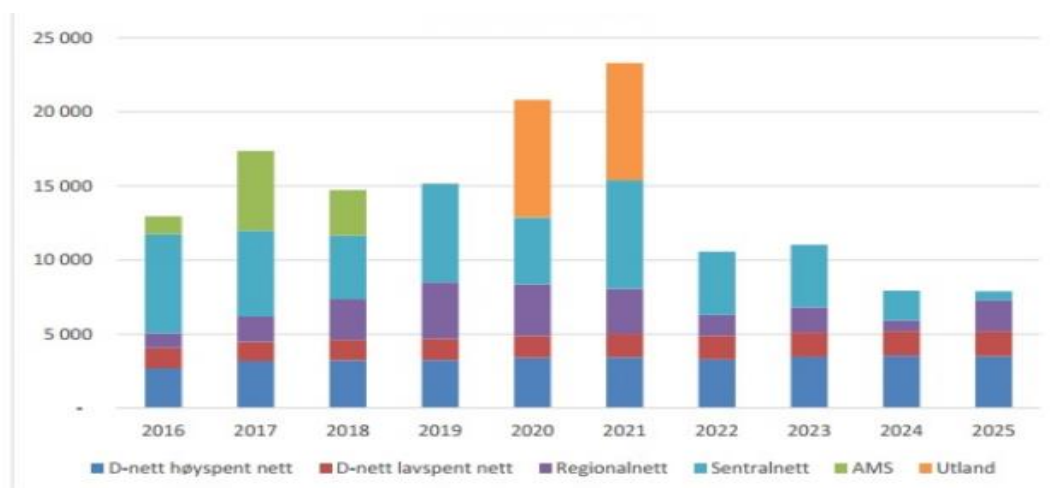

Figure 43: Forward grid investment plans for Norway's grid [26]

Large parts of the net are mature for replacement. An NVE report from 2014 estimated that about one-third of the local distribution network's airlines are over 40 years old and are starting to be ready for replacement. The largest investments in the regional network are planned in Mid Nord Nordland, the Agder counties, South Rogaland and Helgeland, according to the NVE.

The trend has been an increase in the Grid Rental, including fees between 1993 and 2016. Many DSO companies are likely to continue to increase network rent over the next few decades to fund increased network investments.

The planned investments will probably increase the annual grid rent by between 30% and 50%, according to the 2014 report 'A better organized electricity grid' ²⁶. In that case, it will increase the net rent by NOK 2,000 a year for an average household, the report says. However, the regional and local differences will probably be large, and the calculations are highly uncertain. It is in Northern Norway that the net investments are greatest, according to the NVE. The difference between the highest and lowest net rent in Norway is already large. Last year, nearly a thousand NOK a month for a household with a consumption of 20,000 kilowatt hours a year, according to the NVE. For the power price itself NVE expects minor changes, although new exchange capacity is being expanded between the Nordic countries and neighbouring countries. According to the agency's power

²⁶ https://www.regjeringen.no/globalassets/upload/oed/pdf_filer_2/rapport_et_bedre_organisert_stroemnett.pdf

market analysis by 2030 ²⁷, the Nordic countries will be able to export and import up to 70 terawatt hours of power a year, with the export cables being planned.

The power price in Norway will probably increase somewhat as Norway is closer to Europe, especially in southern Norway, NVE believes. In the North of the country, large amounts of wind power are being built, especially the Fosen project of 1,000 megawatts, which is likely to contribute to lower electricity prices in the North than in the South. However, new power cables for Germany and the UK will not increase the Norwegian electricity prices by more than 2 Øre per kilowatt hour in 2030, according to the NVE. However, there will be less variation between dry and wet years, since it will be possible to import more. The power price today can vary as much as 40% between dry and wet years, but this is likely to be reduced to just 10% with new cables.

A map of the areas where the network can receive more power and where there is absolutely no spare capacity is represented in Figure 44. It can be seen that some areas have higher free network capacity than others, and thus greater opportunities to receive new power production from small power plants and wind power.

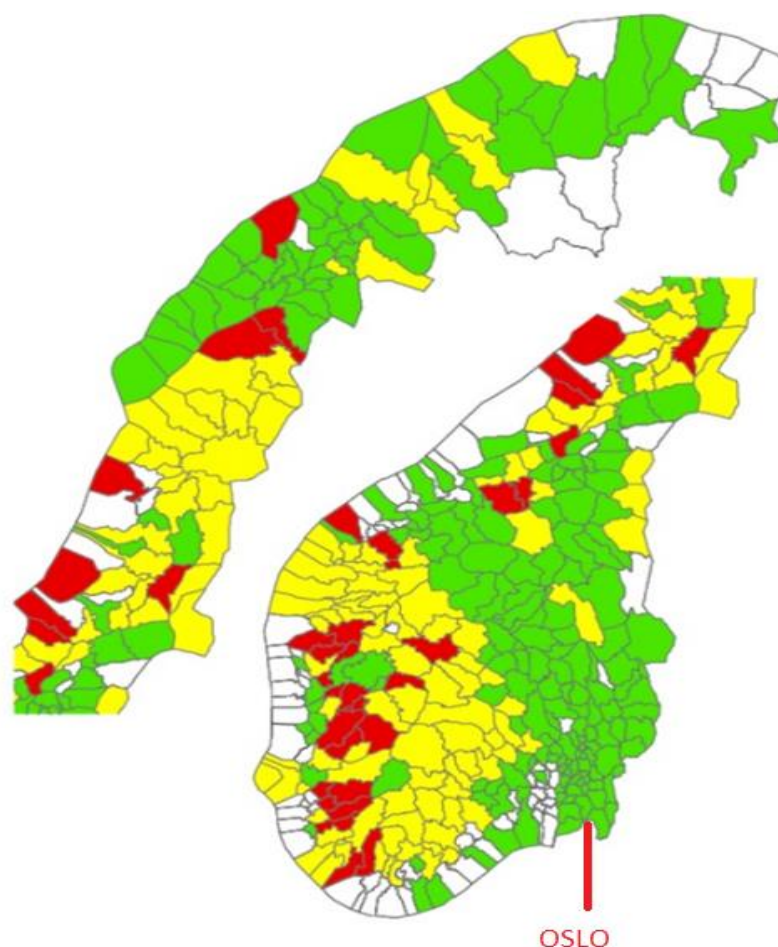

Figure 44: Availability of electric power in Norway (Green = available capacity; Yellow = limited capacity; Red = no capacity; White = unknown capacity) [26]

Peak periods vary in different countries, based on time of day and seasons. Northern countries face seasonal peak demand during the winter. Generally peak occurs between 5 and 9 p.m.; however, in areas with low network capacity, a high share of EVs charging at the same time could create the risk of overloading substations and cables in the distribution network. This risk is expected to be significant in the future, as the total number of EVs increases. A case study from the Norwegian Water Resources and Energy Directorate (*Norges Vassdrags – og Energidirektorat*, or NVE) looking at the city of Drammen estimates that – with smart charging behaviour – the city's current grid capacity could handle future charging.

On the other hand, uncontrolled charging could require grid investments of 1 billion to 2 billion NOK – or around 100 million to 200 million Euros – related to on-peak EV charging.

²⁷ https://www.nve.no/Media/5160/2016_12_nve_kraftmarkedsanalyse_mot_2030.pdf



With increasing EV penetration and uncontrolled charging of electric vehicles, the costs for meeting the power and delivery needs would increase considerably. Peak demand could double if EVs are charged during peak periods. This would needlessly result in significant investment in new generation and network capacity that would operate at very low load factors simply to serve this exacerbated peak.

Hildermeister et al. maintain that:

In some ways, Norway's case is unusual. While time-varying retail energy charges are common, the dominance of hydroelectric supply means there is less need for variable renewables and the variability of the renewables can be largely offset by hydro storage. As a result, regardless of the energy charge structure, the cost of energy is not likely to vary significantly in real time, and the value of shifting energy consumption is likely to remain modest. However, as in many cases across Europe, the dominant network charge structure does not vary with time. In Norway, this is compounded by the fact that 30 percent of the network charge is not volumetric. The combination of a low, stable energy charge, a flat volumetric network charge component, and a large fixed network charge component creates perverse incentives for EV charging behaviour that is already in evidence [27, p. 15].

4.4.2. Example of Cost/Revenue analysis based on 2017 data

1. Cost of energy consumption for EV charging during 02/01/2017- 16/11/2017

Recalling Table 8 of the statistics on the EV charging data, the following information presented in Table 22 is derived from the data provided by the Operational Pilot for carrying out a cost-benefit analysis.

Table 22: Data regarding EV charging fees, energy charged and session duration

	AC	DC	Total
Charging sessions – Total	7,085	3,007	10,092
Charging sessions – Average per day	9.426	22.210	31.636
kWh charged – Total	93,450.89	27,188.28	120,639.2
kWh charged – Average per session	13.19	9.04	11.95
kWh charged – Average per day	292.95	85.23	378.18
Minutes spent charging – Total	1,289,470	64,520	1,353,990
Minutes spent charging – Average per session	20	21.46	20.73
Minutes spent charging – Average per day	4,042.23	202.26	4,244.49

As seen from Table 22, during the period (02/01/2017- 16/11/2017), the EV charging infrastructure consumed 120,639 kWh. The cost of electricity used in car parking garage is estimated as follows:

(1) A fixed connection charge ('fastbelop') at 39.20 NOK/month, which results in a charge of about 431 NOK for 11 months.

(2) Energy charge based on 'forbruk' tariff in 2017 at 51.1 Øre/kWh, which gives:

$$\text{Energy consumption charge} = 120,639 \text{ kWh} \times 51.1 \text{ Øre/kWh} = 61,646 \text{ NOK} \quad (11)$$

Therefore, the total electricity cost for the EV charging infrastructure is about 62,077 NOK.

No information was made available regarding battery degradation and State of Health of either the stationary battery or of the electric vehicles. The latter is apparently not collected at the back-office of Fortum Charge & Drive, and the former may be known to either Fortum Charge & Drive or Ferroamp, but has not been shared. Further, no information was made available on the cost of overheads, wages, etc. for the Vulkan car parking garage overheads.

Ferroamp informed us that the stationary battery was rated for 2,000 cycles when newly installed, and by mid-March 2020 had experienced 1,000 cycles. Also, since the end of 2019 only 5 out of the 7 modules of the stationary battery are performing properly; so the battery has lost 2 x 7 kW of its operational capacity. The loss of one module was due to human errors. A second module had a bad cell, so reducing performance. The rest of the modules (five) have an average residual value of approximately 96%.





2. Revenue from Vulkan car parking garage during 02/01/2017- 16/11/2017

Revenue consist of two parts:

- 1) Revenues from charging;
- 2) Revenues from parking.

The revenues breakdown is as follows for the selected period when these prices were in operation.

(a) Revenues from EV charging

DC chargers: 2.5 NOK per minute.
 AC chargers: Free between 5 p.m. to 9 a.m. weekdays and 5 p.m. to 11 a.m. weekend
 At other times: 22 kW 2.75 NOK /kWh
 11 kW 2.5 NOK/kWh
 7.4 kW 2.25 NOK /kWh
 3.6 kW 2.0 NOK /kWh

255,585 NOK from AC charging

161,300 NOK from DC charging

(b) Revenues from parking (collected by One Park)

Car Parking Charge: 15 NOK per commenced 30 minutes
 Average Time per charging sessions: 20.7 minutes

151,380 NOK from car parking

The total revenue is 568,265 NOK.

Table 23 lists the cost, revenue and the surplus, ignoring BESS battery degradation as well as cost of overheads, wages, etc. It can be seen that during this period, the surplus from combined EV charging and car parking fees minus the cost of the electricity procured to power the EV charging infrastructure and the BESS is about 506,188 NOK. The surplus appears to be too high, which is mainly because the costs of overheads, wages, etc. which were not considered in the calculations, as these were not made available.

Table 23: Cost, revenue and surplus (EV charging, car parking fees, and electricity costs for EV charging and stationary battery charging)

Item	Amount	Unit
Total Revenue:	568,265	NOK
Total Cost:	62,077	NOK
Surplus	+506,188	NOK

The hoped-for Return on Investment for Fortum is only from EV charging and expected to be around 8 to 10 years now. Aspelin Ramm through Vulkan Oslo AS (which is 100% owned by Aspelin Ramm) have a rental agreement with OnePark. OnePark pays for the use of area. Vulkan AS pays for the use of the parking system (AutoPay and meters). Net surplus for parking are divided between Vulkan AS and OnePark as a yearly percentage turnover parking revenue (short term, long term etc.)

It is also worth noting that, unlike other DC charging stations across Oslo where the municipality collects 50% of the revenues, no share of the DC charging revenues at the Vulkan car parking garage go to Oslo City Council.

For completeness, the cost of installations, as per SEEV4-City project financial reporting, is given in Table 24.





Table 24: Cost of installations as per SEEV4-City project financial reporting table

	Unit price NOK ex. VAT	Unit	System price NOK ex. VAT	System price EUR ex. VAT
Charge system contractor		<i>Fortum Charge & Drive</i>		
Battery storage	667,422	1	667,422	70,244
Software development	700	288	201,600	21,218
Management fees	900 hours (price charged per hour not stated)	1,584	1,166,400	122,760
Booking solution	12,000	6	72,000	7,578
Smart charge screens	105,000	6	630,000	66,305
Subtotal			2,737,422	288,104
<i>*Building owner (Aspelin Ramm) has received this invoice</i>				
	Unit price NOK ex. VAT	Unit	System price NOK excluding VAT	
Building owner		<i>Aspelin Ramm</i>		
Smart chargers	6250	100	625.000	
Cabling for control system	700	100	70.000	
Space for battery storage	10000	5	50.000	
Project management	1400	60	84.000	
Construction management	1000	8	8.000	
Subtotal			753.000	

Please note that the 2 DC chargers were apparently not charged to the SEEV4-City project, and were paid for by Fortum Charge & Drive, at a cost of 386,000 NOK per charger.





5. Lessons learnt from the different pilot phases

5.1. Preparation and initiation

The Vulkan SEEV4-City OP is a result of a constructive collaboration between Aspelin Ramm and the City of Oslo's Agency for Urban Environment, with the drive of environmental organizations Bellona and Zero. The starting point was that Aspelin Ramm provided a number of available parking spaces at night and night at the Vulkan car parking garage, while the municipality of Oslo needed more central charging stations for electric car owners. Expanding electric mobility is part of the City of Oslo's overall Climate Strategy 2030 which responds also to national environmental policy targets ²⁸.

The transport sector is a key focus in this strategy and this results in the following targets for Oslo:

- 100% of all passenger cars are battery electric within 2025;
- 100% of all light freight vans are battery electric within 2025;
- 100% of all new heavy freight vans are battery electric within 2030;
- 50% of new trucks are battery electric or hydrogen in 2030;
- 100% of new city buses are battery electric within 2025;
- 75% of long-distance buses are either electric or hydrogen in 2030.

The then Apelin Ramm Director of Environmental and Social Responsibility thought it makes sense to let electric cars charge in parking garages at night because they are often empty. The responsible City Councillor Berg opening the facility described it as:

A user-oriented and forward-looking solution. This is probably the world's most advanced charging point for professional users. It's not often I witness such holistic and robust solutions." The technical installation was provided by Fortum Charge & Drive, and its manager announced it would be upgraded by the summer of 2017, with reservation solutions, free choice of charging speed and payment solutions. "Using a separate app, you can order charging in advance, and you also choose how fast you want the car to be charged." According to Aspelin Ramm's director of environmental and social responsibility at the time, a positive effect of being able to offer electric cars charging and parking indoors at the Vulkan car parking garage is to get cars away from the city streets and then being able as a city to use this space for something more valuable than storing cars. At the same time, one utilizes the capacity of the car parking garage better in this this way. The representative from the Norwegian representative of the Norwegian Electric Car Association emphasized the importance of the plant in the following way: "Charging is milk and bread for all electric car owners, and the establishment of this facility is an important signal to anyone who is considering buying electric car. Oslo sets the standard as an electric car capital ²⁹.

According to the Draft Baseline document within SEEV4-City – handled and compiled by Cenex UK at the time, the initial conception of this Operational Pilot was with a wider systems boundary, and also with a connected local RES sources. The Vulkan Estate buildings aim at achieving 100% energy consumption from renewable sources. They are heated – and lighted – through a district and also geothermal solution, with access to reserve power across the city for this. There was also an ambition for locally-generated PV solar energy production, including power supply to the building in which the Vulkan car parking garage OP is located. Electricity imported from the central grid in Oslo and Norway is 98% from hydroelectric plants and, in that part of Norway, 1% is from wind (and the remaining 1% could be anything imported).

The ambition statement at the conception of the Oslo Vulkan car parking OP was:

To seize the renewable energies, a smart grid scheme with energy storage will be created. There will be a liberal use of EVs (in form of car sharing, taxis and private vehicles) playing a role in the energy storage. The objective is to harness the potential of flexible loading by installing hundred charging stations, and afterwards to include V2G solutions. In total, more than 400 EVs per day will be served, and it is expected a reduction of 20% overall electricity consumption during peak hours. The project is coordinated by local government and aims to replace as many conventional vehicles as possible, shifting in the next years from 400 to 1000 EVs. Besides Oslo, there is the possibility that other partners join the consortium. Among them, there are Aspelin Ramm (a large private real estate company) and the Norwegian EV Association. In addition, there is further

²⁸ <https://www.klimaoslo.no/wp-content/uploads/sites/88/2018/12/Horningsutkast-Faggrunnlag-Strategi2030.pdf>

²⁹ https://www.aspelinramm.no/wp-content/uploads/are_miljo2016_net.pdf





support from private companies: Nissan has expressed interest, and the IT firm Meshcraft is considered for a proprietary navigation software useful to plan travels and reduce range anxiety.³⁰

The City of Oslo did purchase instead a White Label version of Fortum Charge and Drive's CDMC³¹ and this was applied city-wide. This CDMC has many of the same qualities and functions as the Norwegian Meshcraft. Fortum Charge & Drive, the innovation partner of Aspelin Ramm (the real estate company that is the building owner), is responsible for the energy system, in collaboration with their sub-contracted technology partner Ferroamp who installed the BSS. Fortum solely needed the technical information of the building from Aspelin Ramm in its preparation of designing the energy system.

It became clear during the initiation phase that placing a roof-top PV installation for local solar energy generation (50 m²) turned out not be feasible and was vetoed either by the Board of Aspelin Ramm (over fire concerns) or by residents (either also because of fire concerns, and/or because they were in favour of roof-top urban biodiversity, and bees in particular).

The lighting of the car parking garage is perhaps supplied by the district heating and/ or geothermal energy sources supplying the Vulkan estate buildings.

At the conception and perhaps still the initiation phase, the boundary for this operational pilot was the overall Vulkan Estate Buildings using a range of renewable energy sources combined with a smart charging grid (for the EV charging infrastructure to be installed) including a newly installed (50 kW) BESS to support the smart charging of the EVs.

5.2. Procurement

Fortum Charge & Drive installed 50 AC EV charging units, with 100 AC smart charging connectors, 50% subsidised by SEEV4-City (cost: 625,000 NOK exclusive of VAT). They also installed cabling for the control system for these 100 AC connectors (cost: 70,000 NOK exclusive of VAT).

The 2 DC charging units, with 2 connectors each, do not appear to have been (as yet, at least) been charged to the SEEV4-City project (with the associated 50% match-funding), and were paid for by Fortum Charge & Drive at a cost of 386000 NOK per charger. Apparently, this has never been claimed against the SEEV4-City project, and thus has not attracted 50% match-funding.

There was the substantial development of software procured, likely the one sub-contracted to a third party (of unknown identity) in connection with the BESS and the AC and DC chargers (cost: almost 144,000 NOK exclusive of VAT).

There was also the procurement of a pre-booking system of the EV chargers (cost: a bit under 7,600 NOK exclusive of VAT).

Furthermore, there was the procurement of smart charging screens, likely associated with the EV charger units, to enable better customer experience, the handling of EV charging and explaining functions and payment (cost: just over 66,300 NOK exclusive of VAT).

Finally, a brand-new Li-ion BESS was procured for the Oslo OP by Fortum Chare & Drive (with the 50% SEEV4-City match-funding) from Ferroamp. The current BESS installed cost about €80,000 inclusive of VAT (which currently is 25% for the standard rate).

The overall internally calculated, amongst the local Oslo OP project consortium, Return on Investment (RoI) is said to be about nine years (perhaps longer now with COVID-19, and an earlier downtime in collecting EV charging fees for about 2 months during the migration of the back-office functions).

The algorithm controlling the pre-programmed discharging and charging of the stationary battery (to the EV charging infrastructure and from the central grid a set thresholds of collective power consumption of the EV chargers was outsourced to another third company (the identity of which is currently unknown to the report authors), and neither Fortum or Ferroamp appear to have any detailed insight into this.

Fortum Charge & Drive built, and is responsible for, the entire OP energy system (the DC-nanogrid and any imported electricity from the central grid) and has invested (human) resources in the development phase to penetrate this for them new market, though they now have range of business offerings in terms of products and services that relate to EV charging, BESS and energy storage across the Nordic countries.

³⁰ Source: SEEV4-City Baseline document prepared in Summer 2017 by Cenex UK

³¹ <https://www.fortum.com/cdmc-ev-charging-platform>





5.3. Implementation and installation

The cooperation between Fortum and Aspelin Ramm for car parking installations in the Oslo OP faced no problems or significant delays, though perhaps there was a slight one over having to check and verify fire safety issues with the installation of the stationary battery in the Vulkan car parking garage.

The Ferroamp system connecting the BESS with the EV charging infrastructure (AC and DC collectively) was installed in February 2017 by Fortum Charge & Drive with the overall Fortum design and Fortum-Charge & Drive procured and externally developed control algorithm, and the Ferroamp databased became live then.

There were a number of times where some ICT issues were encountered. When Fortum (Charge & Drive) took the decision to migrate all their back-office function to a central back-office there was apparently a short local rebooting issue in May 2018, and in order to not aggrieve customer during the migration phase no EV charging fees were collected from the AC chargers. Also, no data is thus perhaps or apparently available for this period on the EV charging for the UNN researchers in Excel etc format. The two DC chargers are apparently not connected to the new central Nordic back-office of Fortum, due to an ICT issue with the new OCPP 2.0 protocol, and are locally supported.

Fortum Charge & Drive is the organisation which collects the EV charging data from the carpark in the Oslo Vulkan car parking garage OP. This comprises mainly logged data from the charging points such as charging sessions and amount of kWh charged. There is no hard data is available the researchers or Oslo City Council as yet regarding the characteristics of the cars (such as EV battery capacity, SoC, SoH etc) or soft data (such as the type of cars from EV users or state of ownership). Retrieving the soft data is apparently not interesting for Fortum Charge & Drive from a business case perspective. It would be of interest from a scientific and contextual perspective (and may well be of commercial strategic interest by the real estate company) but this requires additional human resources for data analysis, which is expensive and Fortum Charge & Drive's back-office – when this was discussed with the SEEV4-City UNN researchers – could not see how they would facilitate that.

Oslo City Council would like to have a higher resolution of data in terms of different user groups (residents, professional users, and open city users). A survey questionnaire had (in Excel) template been designed between Oslo City Council and UNN researchers by the end of 2019. The understanding before that was that the building owners, Aspelin Ramm, would commission a professional survey company to undertake the survey, albeit with the analysis assistance of UNN researchers. It is not known by the report authors why this survey was not implemented by mid-March 2020, when the COVID-19 restrictions made it at least temporarily (and until now) unfeasible to implement the survey on location. An online survey of professional users and residents could still be considered but apparently has not been determined on by the local Oslo OP partners (though a draft was developed for this with UNN) and will not now occur now within the lifespan of the SEEV4-City pilot.

5.4. Operation

The V2X units in the Oslo Vulkan car parking OP required a software modification in order to interact with V2X-enabled EVs. This was done during the SEEV4-City pilot for the AC chargers (which are now 'V2G ready') in December 2017, when standard AC chargers were replaced with or upgraded to flexibly rated ones. This is perhaps not quite concluded fully for the two DC chargers, though in principle they are also capable technically, but they are apparently not connected to the Fortum's new Nordic back-office.

The energy system features three layers of defences to prevent system demand overload for this DC nanogrid when too many EVs are charging at the same time and create a collective demand for the AC and DC chargers (as the system in place does not and cannot treat this separately):

- The first layer of defence is phase-balancing via the inverter. Depending on which parking spot they occupy, the charging EVs end up on different phase connectors. The capacity is dynamically balanced over those three phases to which the charging units are connected. Currently, many of the EVs on the roads of Oslo also using the Vulkan car parking garage are Single Phase EVs. When the demand on one of the phases is higher than the others, the inverter will balance the capacity but by only 40-50 kW/h.
- The second layer of defence is to utilise the battery to peak shave the demand. When the power demand from the EV chargers collective is exceeding a set threshold (which was adjusted from its original setting due to now higher demand, pre-COVID-19 restrictions) the BESS will discharge to support the DC nanogrid system and will charge again from the central grid once the collective power demand from the EV chargers drops below another pre-defined (and now adjusted from its original setting) threshold. The BESS was arguably dimensioned properly at the time of installation for this intervention; however, due to the growth of EV charging at the Vulkan car parking garage, the effect of the BESS is almost





negligible right now in terms of peak shaving and thus also electricity cost savings for the EV charging infrastructure operator Fortum Charge & Drive. Also, the battery has reduced in capacity significantly due to two modules (7 kWh each) with a problem and not properly functioning.

- The third layer of defence would reduce the power output of the charging units.

This installation being one of the first charging systems with multiple layers, these layers are not communicating with each other. Nowadays, these types of installations are smarter and are able to communicate and interact with each other. The control strategies depend on the location's situation (steering on load demand management, or through dynamic electricity tariffs etc. – the latter not being in place in Norway so far). The 1,250 A supply feeder capacity for the parking garage is well above the current peak demand, which means that there is still headroom to charge even more EVs in the Oslo Vulkan garage for the near future.

Initially, the AC chargers were free to charge from at all times, day-time and night-time. EV charging infrastructure users were able to choose what speed to charge with via a mobile application. In the week of the end of October and the beginning of November 2018, Fortum introduced a flat day-time fee for the use of the AC chargers for all users. This saw some temporary albeit brief dip in EV charging sessions on the AC chargers, but it pretty quickly recovered. DC charging remained (mostly) pricier than AC charging. Whilst Fortum Charge & Drive migrated all their Nordic operations to a brand-new Nordic back office system, with new native apps to end users, charging fees were suspended during this migration in May of 2018.

At the end of May 2018 until at some point (in October 2018), Fortum introduced a more differentiated AC charging fee structure: The user could charge at 7.4 kW, 11 kW and 22 kW, with different prices charged for different AC charging speeds. A publicly available Fortum Charge & Drive PowerPoint Presentation [28] is suggesting that, at least for a while, some AC charging may have been pricier (“AC: 2,00 – 3,00 NOK/kWh depending on effect selected”) than DC charging (“Standard price since 2012: NOK 2,50/min. Rationale: Minimize unnecessary usage/ blockage, better customer experience”).

According to Fortum Charge & Drive, this differentiated AC charging pricing model ‘turned out to be too complex for users to deal with this price model’. After June 2019, the AC chargers pricing model was simplified, and since then there is a set charging fee, and a higher one for the DC chargers. According to Fortum Charge & Drive (mid-January 2020): ‘As predefined price policy, the EV charging tariffs may vary with time. Currently, this is a static tariff policy, and the technology installed at the Vulkan car parking garage will not allow different tariffs based on dynamic (electricity) tariffs in the market’.

Oslo City Council have decided that all EV users have to pay for charging. The first locations in the city were made ready for user payment from March 3rd 2019. By 31st December 2019 nearly all sites were charging a small fee of NOK 10 per hour (including parking) during the day (9 a.m. – 8 p.m.) and NOK 5 per hour during the night time (8 p.m. to 9 a.m.). In this connection, Oslo City Council will start charging fee for over-night charging for residents at Vulkan of NOK 5 per hour during night; this will most likely be implemented in the autumn of 2020. The goal is to bring this in line with the general policy for on-street EV charging.

The numbers of EV charging sessions (with the average AC and DC charging lengths not significantly changing), as well as the electricity volume charged by the EVs, are increasing (at least before COVID-19 restrictions came into effect in mid-March 2020).

5.5. Overall for the Vulkan OP

The following lessons have been learnt, based on the operational pilot analysis carried out so far:

- The operational value of peak shaving of (the collective) electricity demand by the (AC and DC) EV chargers has diminished over time since the relative capacity of the stationary battery (50 kW / kWh) is now small to marginal compared to the (much increased since 2017) EV charging demand. Also, the stationary battery has currently 2 out of 7 modules which are not functioning properly, and could be replaced (at a cost). In the future, the building and car parking garage owners could consider the use of a (new generation, with a significantly lower price per power/energy density rating and arguably improved battery chemistry and this cycling lifespan) perhaps significantly larger stationary battery, especially if this is also meant to engage with the building power demand, beyond purely EV chargers (which would need a different electric connection logic to be then implemented).
- In the next iteration of commissioning a new system (see above) either just to support EV charging peak shaving or also peak shaving of building power demand consideration should arguably be given to a more integrated procurement and systems design, namely a built-in alignment between the stationary battery, an API or algorithm development, the actual EV charging installations and electrical support and – if this is widened to building peak demand shaving – also those electrical dimensions and requirements.





- All the AC chargers are now 'V2G-ready': the hardware is suitable but needs additional software and adjustment in the cars to be usable/effective (V2G capable cars and perhaps warranty from OEMs).
- For the time being (at the time of writing), one of the core OP partners (the City of Oslo) decided against (Norwegian government match-funded) new investment into a new generation of higher-rated (super-) fast chargers at the Vulkan car parking garage, preferring to leave that investment decision to the private sector partner, the building/ car parking garage owners Aspelin Ramm in the future, depending on projected demand for this from their clients.
- The Norwegian and Oslo electricity tariff is now composed of an energy tariff (NOK/kWh) and a capacity tariff (depending on the heaviest use/peak, in one hour in a given month, as well as the peak demand in the winter (triad) period) and an environmental tax [29]³². It has thus changed from a 'volumetric' to a 'capacity-based' tariff logic [30].
- Consumers who purchase power for their own consumption are called end users. End users in Norway are free to choose their power supplier. Generally, end users in Norway can choose between three main types of electricity contracts: fixed-price, standard variable price and spot price (based on market prices, with a mark-up) [31]³³.
- An end user's total electricity bill consists of charges for several different components of the service: the electricity (power price), connection to and use of the electricity grid (grid tariff), consumption tax on electricity (electricity tax), and value added tax. In addition, there is a fee earmarked for the national Energy Fund (Enova), as well as payment for electricity certificates. The power price makes up a varying share of the total end user price, depending on market prices. The electricity tax and the Enova fee are fixed by political decisions, while the price of electricity certificates varies depending on developments in the electricity certificate market. Grid tariffs are fixed by the grid companies, based on a revenue cap and principles for tariffs laid down by the Norwegian Water Resources and Energy Directorate. Grid tariffs are required to reflect the costs of transporting electricity to end users [31]³⁴.
- V2B is currently legally regulatorily unproblematic in Norway, but V2G in terms of exporting to the grid has regulatory barriers since the energy regulator's control of the design of the electricity markets has not yet allow aggregated services to bid in the electricity markets [1].
- Requirements regarding the quality of the power fed back to the grid may be an issue as well as the price that is offered for feeding back (as is currently the case in Norway for exporting from solar panels back to the grid).
- Currently for the commercial partners, the business models for Smart charging is better than that for V2G, because smart charging delivers on peak shaving (on price), especially in the morning.
- Load balancing in the building currently is seemingly not a problem (though we do not have actual measured data on this), which makes the BESS not essential for the present time for this wider building context. Testing was instrumental for future learnings.

³² The ENOVA fee or levy is a parafiscal charge on the electricity distribution tariff, to finance the state funding body for energy/ sustainability/ renewable industries (and E-mobility) projects; see p. 11 in: <https://www.energinorge.no/contentassets/525e77b1feff4203a94ef6d1f94cfd03/electricity-costs-of-energy-intensive-industries-in-norway.pdf>

³³ In a fixed-price contract, the electricity price is fixed for a certain period, for example a year. The supplier is obliged to deliver electricity at this price, regardless of whether market prices go up or down. Thus, a fixed-price contract is a type of financial contract, where the customer is guaranteed a certain price for the period of the contract. A power supplier sets the fixed price on the basis of expectations about electricity prices, with a mark-up to cover costs. The difference between the fixed price and the market price is the risk premium paid for the guaranteed price. In a standard variable price contract, the electricity price varies with developments in the power market. This is also a form of financial contract, but with a short price guarantee period. A supplier is required to inform customers of price changes 14 days before they are put into effect. In a spot-price contract, the price follows the market price determined by Nord Pool. In addition, the customer must pay a mark-up. For households and small businesses, this option is the closest to taking part in the day-ahead market. In: <https://energifaktanorge.no/en/norsk-energiforsyning/kraftmarkedet/>

³⁴ For 2018 annual average data across Norway, for instance, this meant a proportion of the overall electricity costs charged to end consumers made up by 45% from the power price, 28,7% from the grid tariff (connection), 23.5 from VAT, 2.6% from the electricity tariff, 1% from the energy levy. See: <https://energifaktanorge.no/en/norsk-energiforsyning/kraftmarkedet/>





6. Conclusions and Recommendations

6.1. *Issues for further consideration*

If this OP report were to be taken forward in the future after the end of the SEEV4-City project, further information would be required, and the following issues would need to be clarified.

Information and data required as listed as follows:

- Information on the potential ancillary services adoptable by the Oslo OP;
- If and when the two faulty BESS modules might be replaced;
- If and when the building or service providers may decide on the procurement and installation of ultra-fast chargers;
- An up-to-date EV charger dataset, covering the period when smart charging functionality was enabled, would be needed for further analysing the smart charging performance of the pilot baseline and for evaluating the achieved improvement in the KPIs by implementing EV4ES;
- Apart from the charging durations, data of periods when EV is connected to the charger without charging actions should also be provided, either as part of Dataset 1/Dataset 3, or as a separate file. This dataset would help to provide information the EV availability for smart charging management;
- Parking data from One Park – the parking manager – would be required for installing/analysing smart parking management, in order to maximize the garage utilization and promote the use of EV.

The following clarifications would be needed to strengthen the OP analysis:

- Data gap in the Ferroamp record between 13/04/2018 and 07/06/2018.
- Which parts does the consumption data in Dataset 2 and Dataset 3 cover in the Oslo OP?
- How to cope with the missing data for the 46 AC charging points in the 'DC' sheet from Dataset 1?

In addition, a qualitative survey of EV charging infrastructure for the Oslo operational pilot would bring benefits to understand user acceptance and behaviour – especially of professional users and residents:

- The additional qualitative data obtained via a survey/ questionnaire with professional users and residents of the Vulkan car parking garage (disaggregated between the two, as they have different user profiles and needs) would allow to explore disaggregated data concerning the stated preferences and behavioural routines of these groups which are likely distinctive;
- The results of the questionnaire should then be benchmarked against the background of existing EV user behaviour and experiences, i.e. by the Norwegian Electric Vehicle Association (Norsk Elbilforening);
- This would then allow for further consideration of potential barriers and enablers of the uptake of the service provided, in connection with the business model and technological system in place (including prospective, i.e. stated preferences, user acceptance of V2G if this was to be implemented).

6.2. *OP site-specific recommendations for the future*

If a new evaluation of the OP, then on a commercial basis only, were to be undertaken in 2021 or 2022, several aspects should be singled out for consideration:

- If one were to install a new BESS in connection with the EV charging infrastructure, it would probably make sense to differentiate in the systems architecture between the AC and the DC chargers. This would especially apply if the Vulkan car parking garage business partners decided in favour of investing in some ultra-fast chargers;
- If the regulatory landscape around V2G were to change in Norway in 2021 or 2022, and dynamic electricity tariffs were to be implemented in Norway and made available in Oslo, making the current V2G chargers also 'V2G ready' could be considered;
- If EV (and BEV in particular) penetration were to increase in Oslo in line with Oslo City Council's policy targets and, as assumed in the linear increase in the report also for the forthcoming years towards 2025, the Vulkan car parking garage were to experience a corresponding increase in EV penetration of its





vehicle users, as well as EV charging electricity and especially power consumption, then during 2024 the critical limits of the current installation would be reached;

- If the above applies, this would make a reasonable case for a sized-up ESS for the EV charging infrastructure;
- In this case, a more integrated procurement and development of the ESS and the controlling algorithm should be considered;
- More integration of smart parking management and EV charging infrastructure management should be considered with a higher penetration of EVs at the Vulkan car parking garage;
- All of the above is independent from a wider smart energy management of the building – even the lighting of the car parking garage. There may well be energy savings and power peak shaving that could be affected in case of a more integrated systems between the EV charging infrastructure and the energy and power loads of the building hosting it. This in combination with an ESS and perhaps the district heating system at the Vulkan estate overall, or the thermal energy system at the Vulkan estate.
- The potential benefits of utilising the BESS system to reduce liability to the 'Effektledt' peak power tax were not found to be fully exploited, for instance the January 2020 peak of 378 kW was not mitigated by the BESS system, and in the absence of use to systematically reduce the largest monthly peak power level, the opportunities for grid reinforcement deferral offered by the use of BESS cannot be fully taken advantage of. It is suggested that the controlling BESS algorithm be examined to ensure that, as far as practicable, it operates the BESS output to reduce the largest grid peak power demand.

6.3. *Relevant dimensions for Upscaling and Transnational potential*

In this section we provide a brief indication of which dimensions SEEV4-City identified for the EV4ES used in this OP that play an instrumental role for both its Upscaling and Transnational transfer potential.

6.3.1. Oslo

In the case of the Vulkan Oslo OP, this is Peak Shaving of EV Charging Infrastructure Electricity Demand from the Grid by way of a EV Charging Infrastructure connected with a Phase Balancing Inverter and a Stationary Battery pre-programmed to discharge to the collective EV Charging Infrastructure above a set power demand threshold (within a DC nano-grid) and charging from the central grid at another (much lower) power demand threshold.

In this OP analysis report we are highlighting the currently performed (see paragraph above) and future potential EV4ES/ Energy Services (ES).

Peak shaving of EV charging (both BEV and PHEVs) is important in Oslo, as it is anticipated that – due to the aged cabling in Oslo's neighbourhoods, bottlenecks on the local grid will otherwise materialise before too long, especially with the ambitious EV targets of Oslo City Council in relation to both private, shared and professional EV users. This is even without high-powered charging (ultra-rapid). Parking garages and parking spaces for multiple EVs are important in Oslo since 61% of Oslo residents are currently living in multiple-family buildings (apartments or townhouses).

Another European (Horizon 2020) project in Oslo, with the key participation of the municipality of Oslo is the **GreenCharge Project**, which has many qualities related to the Vulkan OP but also others in addition to it. In the Green Charge Oslo pilot, there is a particular focus on providing cost-efficient EV home charging (privately owned EVs) facilities for inhabitants living in blocks of flats, with limitations in the local power grid. Most inhabitants have their own dedicated parking space inside a parking garage. Before the GreenCharge Oslo OP started, the housing association had established four charging points outside the parking garage, where access to these charging points are granted through a simple booking interface. When the GreenCharge project started in Oslo 2 years ago at the site of a housing association, the capacity for charging of EVs there were less than 20 cars out of a total of 238 parking places. Now all can charge by cabling all parking places with smart grid solutions (connected heating), battery storage and also on-site solar energy generation. The Oslo GreenCharge pilot aims to will implement charging management to ensure that total power for charging is within the grid limitations, and the site will also consider the integration of local solar power and assess improvements possible with BESS. In the GreenCharge Oslo OP pilot, EV charging will mainly take place inside a parking garage, but outside semi-quick charging will also be offered. The GreenCharge Oslo OP focuses on Smart Charging, investigating how a booking system for charging services can be directed towards certain customer segments, how a booking system can help predict power needs and improve load balancing, and also how the user interface and services for EV charging will work in different situations and for different user groups. In terms of the integration of local renewable energy generation sources (RES), the Oslo GreenCharge pilot investigates





how an integrated smart charging solution can balance the charging of EVs with local energy usage and electricity production. In terms of business models, the focus is on how housing associations can facilitate cost-efficient home-charging with limited grid capacity. The Oslo GreenCharge pilot aims to develop new business models with an intelligent billing system in order to increase consumer acceptance and to take ownership dimensions into account ³⁵.

The potential for the expansion of EVs in the Norwegian markets amongst private vehicle users has been shown for Oslo by the trend data of the recent years. A Norwegian survey of BEV and PHEVs owners by Figenbaum and Kolbenstvedt in 2016 [32] identified the type of users, their vehicle use, their purchase motivation and how they rated this transport technology compared to ICE vehicles. EV owners are found to be typically younger, with more children and vehicles, with a higher share of being employed, and with longer work trips than other groups. BEVs are overall and on weekdays used more, but less on holidays. BEV users manage their everyday driving without significant issues, as only 6% aborted their trips and 83% never abandoned their planned trips – and improved EV charging infrastructure could reduce the remaining service issues by half. PHEVs were driven for 55% of the kilometres in electric mode and for 63% whilst on work journeys. Reduced operational cost and environmental considerations motivate EV purchasers, as do incentives such as the free toll roads in the case of BEV users.

Electrification of professional users also needs a boost in Oslo. Julsrud et al.'s 2016 investigation [33] into Norwegian crafts and service companies which have adopted utility EV travel patterns in the enterprises is important. Their analysis of a sample of those enterprises shows that a potential replacement of ICEs (diesel vehicles) could be relatively easily be achieved for 37% of those vehicles, representing 13% of those companies' transport activities. For the sample it is derived that an increase in either the range of those utility EVs by 50% or by charging them during the day could increase the substitution of ICEs by 64%. The report finds that this could represent a 41% reduction in GHG emissions from all vehicles in the crafts and services sector.

Over 2019, the City of Oslo facilitated 20,000 new charging points across the city, through a grant scheme for private citizens and businesses. The terms and conditions of this are that the city provides a grant of 20% of all investments for EV charging needed at housing associations and housing cooperatives. Users must pay for the physical hardware, such as the wall boxes [12].

The current Oslo City Council EV infrastructure expansion strategy centres in part around the establishment of new 'green mobility houses', in partnership with shopping centres, property companies (such as in the SEEV4-City Vulkan car parking garage OP), charging point operators, retail chains and housing cooperatives [12]. In May 2020, Oslo had 1600 standard and 200 fast chargers. High-performance charging (ultra-rapid) will also be introduced in Oslo this year. These currently exist in high-way corridors in Norway, by Fortum Charge & Drive in April 2018 just south of Oslo (20 minutes' drive towards Helsinki) ³⁶, Bu and also Ionity ³⁷. Oslo City Council will also enable wireless charging as one technology for EV taxis, with a first such provision planned in 2020 for Olav Vs gate in cooperation with Fortum Charge & Drive ³⁸, but it may also eventually include other locations such as the Vulkan car parking garage. Whilst the exact segment distribution of the different users EV users of the Vulkan car parking garage, such as electric taxis, freight electric vehicles, craft & service, and private cars is not known for the Vulkan car parking garage as this is not automatically detected in the backend system of Fortum, Oslo City Council have tried to promote the Vulkan car parking garage directly to relevant stakeholders such as the 5 largest taxi centrals in Oslo. At present, however, Oslo City Council assumed that there are more electric craft and service vehicles than taxis.

6.3.2. Norway nationally

It is also assumed that at present, there are not too many V2G capable EVs on the Norwegian and Oslo market and roads, though this may well increase in the coming years (>2025). Currently, there are only a few EV manufacturers (such as Nissan, Mitsubishi, Renault, Kia, each with only a few models on the market) that have DC V2X capabilities via the ChaDeMo charging standard: namely the Mitsubishi iMiev (compact PHEV, with now a 47 kWh battery), the Mitsubishi Outlander (PHEV, a sports utility vehicle, with a 13.8 kWh – estimate of usable is 11 kWh), the Nissan Leaf (BEV, now with a 40 kWh battery in its latest model), the Nissan eNV200/Evalia (BEV family car, with a 40 kWh battery), Kia Soul Electric (BEV with a 64 kWh battery). Renault participates in the WeDriveSolar project in Utrecht (the Netherlands) to develop AC bi-directional charging with the Renault Zoë. Besides the ChaDeMo charging standard used for V2X operations, the Combined Charging

³⁵ <https://www.greencharge2020.eu/pilot-sites-oslo/>

³⁶ <https://www.fortum.com/media/2018/04/fortum-charge-drive-builds-first-high-power-charging-corridor-between-oslo-and-helsinki>

³⁷ <https://www.electrive.com/2019/04/10/ionity-opens-first-high-power-charging-corridor-in-norway/>

³⁸ <https://www.theverge.com/2019/3/21/18276541/norway-oslo-wireless-charging-electric-taxis-car-zero-emissions-induction>





System (CCS) has the objective to integrate bidirectional charging features to enable power transfer from the vehicle to a home or the grid over the next couple of years. Tesla is also reported to be planning to add AC bi-directional charging provision in the near future (for its Cybertruck, scheduled for November 2020, though it is unclear whether this will also extent to its Model 3³⁹). However, Norway so far lacks an V2G enabling policy framework [1], and currently V2G would be treated in the same way as solar feed-in to the grid. Furthermore, in Norway the price one receives for energy fed back into the grid is sometimes very low.

One may assume that some of the contrarian debates in transportation and environmental economics will resurface in time for the decision by the Norwegian parliament and government as to whether or how and to what extent to continue the extensive range of incentives for EVs in Norway beyond 2021. Those questions circle around ‘what economic incentives make the purchase and use of EVs in Norway so attractive to road users; if and which incentives have any adverse effects and, if so, how large are they; and how does the marginal external cost of EVs compare to that of conventional vehicles’ [34].

Aarestrup Aasness and Odeck answer those questions posed by themselves in a fashion critical of a continuation of the current Norwegian EV incentives policy:

We find that the Norwegian government has used a wide range of economic incentives that have made EVs much cheaper to purchase and use. Among the incentives are exemptions from taxes, toll charges, parking fees and access to transit lanes. Translated into money, these incentives are a huge savings and naturally have induced Norwegians to buy and use EVs in large numbers. We also find that many of these incentives have some unintended effects. For instance, exemption from toll payments has resulted in a reduction in toll revenues, and access to transit lanes has resulted in congestion on those lanes, leading to increased travel time for public transport users. We note and illustrate why such types of incentives should not be given to EV users [34].

They also explicitly state that since the carbon intensity of the electricity production matters for the contribution to the GHG reduction impacts of the substitutions effects of EVs, and in their view only hydropower (as in Norway) makes the critical difference, the Norwegian incentive policy for EVs should not be transferred to other countries.

If the Electric Vehicle for Energy Services concept is brought in more, with policy and regulatory reforms on grid services and energy trading to the grid, this may well make a difference to this discussion in the near future. This may well be another ‘window of opportunity’ discussed by Figenbaum [35] in explaining how Norway became recently a lead market for EVs. Figenbaum concluded that ‘Norwegian purchase incentives are large enough to make electric vehicles a competitively priced alternative for vehicle buyers. Increased selection of models, improved technology, reduced vehicle prices, and extensive marketing have spurred further sales’ [35, p.14]. All of this is relevant again, with V2X and new capabilities for Electric vehicles for Energy Services when this is fully enabled in Norway beyond smart charging.

Figenbaum et al. [36] have argued that ‘a long-lasting interaction between private enterprises, public authorities and non-government organizations, combined with a taxation system that gives the authorities opportunity to influence vehicle purchase and to compensate for marketing challenges related to price, have supported the Norwegian diffusion of electromobility. In addition, a high share of multi-vehicle households and a publicly supported expansion of charging stations have made range challenges manageable.’ These factors are arguably still both in need – in terms of Electric Vehicle for Energy Services and Grid Services - and in evidence also in terms of the socio-demographic groups for whom electric mobility needs to both stay and for new adopters become attractive. The challenges of this transition, at pace, need to be managed and exploited in a smart way.

Smart EV charging systems to improve the energy flexibility of ‘zero emissions’ neighbourhoods in Norway are to be expected and need to be a part of this transition, with even smarter technology interaction than has so far proved possible for instance at the Vulkan OP site, despite all its innovative advances and contributions [37].

Once Electric Vehicle for Energy Services have been more expressly explored and implemented in Norway, once can then revisit the April 2014 assessment by the Centre for Public Impact [38] in terms of their legitimacy criteria (i.e. public confidence, stakeholder engagement, political commitment), their policy criteria (i.e. clear objectives, evidence, feasibility) and their action criteria (i.e. management, measurement and alignment).

³⁹ <https://electrek.co/2020/05/19/tesla-bidirectional-charging-ready-game-changing-features/>;
<https://electricrevs.com/2020/05/21/viral-article-on-tesla-bidirectional-ac-charging-is-debunked/>





6.3.3. Transnationally

Clearly, many larger cities in the North Sea Region of Europe and elsewhere in Europe have a significant share of their population which live in apartments or townhouses, and therefore are not going to have their own home charging facilities for EVs. Likewise, professional EV users and craft & services EV users will also be in abundance in those cities too.

Eaton Xstorage Building's White Paper on 'Making Stadiums and Arenas more resilient and energy efficient' also mentions that:

Commercial premises and venues with carparks, such as shopping centres, supermarkets, leisure centres, stations, airports, not to mention stadiums and arenas, have an opportunity to provide charging infrastructure for their customers ... In future carparks could also be fitted with smart charging equipment, to encourage local residents to park their cars overnight or for longer periods to take advantage of off-peak times. However, installing this equipment will increase energy requirements to ensure there is sufficient capacity to meet any peak in demand from charging EVs [39, p. 4].

Sørensen et al's report on Smart EV Charging Systems to Improve Energy Flexibility of Zero Emission Neighbourhoods [37] also references other NSR countries' contexts, such as conceptually in Belgium/ Flanders and also for a large fleet car park in Denmark, which share some key smart charging characteristics with the Oslo Vulkan OP. Figenbaum [40] underscores that Norway is a world leader in adopting BEVs.

A more in-depth analysis of the potential of each individual EV4ES applied across the SEEV4-City OPs (in the case of the Oslo Vulkan car parking garage OP, as it is currently set up, peak-shaving of EV charging power with the aid of a BESS) can be found in a separate report on Evaluation, Upscaling and Transnationality on the SEEV4-City website.





References

- [1] Kester, J., Noel, L., Zarazua de Rubens, G. and Sovacool, B.K, 'Promoting Vehicle to Grid (V2G) in the Nordic region: expert advice on policy mechanisms for accelerated diffusion', Energy Policy, Vol. **116**, pp. 422-432, 2018.
- [2] Norway and the European power market, <https://www.nve.no/energy-market-and-regulation/wholesale-market/norway-and-the-european-power-market/>, (accessed 28/02/2019).
- [3] Cenex UK (McLeod, M. and Cox, C., V2G Market Study. Commissioned by and prepared for Innovate UK, released on 27/07/2018, <https://www.cenex.co.uk/app/uploads/2019/10/V2G-Market-Study-FINAL-LCV-Edition-with-QR-Code.pdf>).
- [4] <https://www.nordpoolgroup.com/> [Nordic/baltic/CWE]
- [5] The Norwegian Tax Administration (2020). Electrical power tax. <https://www.skatteetaten.no/en/business-and-organisation/vat-and-duties/excise-duties/about-the-excise-duties/electrical-power-tax/> (last accessed 28 August 2020)
- [6] Hoekstra, A., 'The underestimated potential of battery electric vehicles to reduce emissions', Joule, Vol. **3**(6), pp. 1412-1414, 2019.
- [7] Stolworthy, M. (2020) GB Electricity National Grid CO₂e Output per Production Type. [http://gridwatch.co.uk/CO₂-emissions](http://gridwatch.co.uk/CO2-emissions) (last accessed:28 August 2020)
- [8] Odeh, N., Hill, N. and Forster, D., Current and Future Lifecycle Emissions of Key 'Low Carbon' Technology and Alternatives, Final Report, RICARDO-AEA, April 2013
- [9] Hall, D. and Lutsey, N., Effects of battery manufacturing on electric vehicle life-cycle greenhouse gas emissions, The International Council on Clean Transportation, 2018.
- [10] Norsk Elbilforening (2020) Norwegian EV policy. <https://elbil.no/english/norwegian-ev-policy/> (last accessed 28 August 2020)
- [11] World Economic Forum (2020). The Oslo model: how to prepare your city for the electric-vehicle surge. <https://www.weforum.org/agenda/2018/08/the-oslo-model-how-to-prepare-your-city-for-electric-vehicles/> (last accessed: 28 August 2020)
- [12] Portvik, S., "The World's First Mass Market for Electric Vehicles -The Oslo Case Study." Carbon Neutral Cities Alliance, 2019. Available online at: <https://carbonneutralcities.org/building-a-ubiquitous-electric-vehicle-charging-infrastructure/>
- [13] Lemphers, N., Rolling the snowball: Norway's efforts to electrify transportation. EGL Working Paper 2019-2, September 2019. Environmental Governance Lab, Munk School of Global Affairs and Public Policy: University of Toronto, 2019
- [14] Skov Kristensen, F., Lauge Thomassen, M. and Jakobsen, L.H., Case Study Report: The Norwegian EV initiative (Norway). Brussels: European Commission, Directorate-General for Research & Innovation, Danish Technological Institute and Joint Institute for Innovation Policy, 2018. Available at: http://www.jiip.eu/mop/wp/wp-content/uploads/2018/09/NO_Electric-Vehicles-Initiative_SkovKristensenLaugeThomassenJakobsen.pdf
- [15] European Alternative Fuels Observatory (2020) Norway. <https://www.eafo.eu/countries/norway/1747/incentives> (last accessed: 28 August 2020).
- [16] Pushevs (2017). Electric cars range and efficiency (NEDC). <https://pushevs.com/2017/05/23/electric-car-range-efficiency-table-nedc/> (last accessed 28 August 2020)
- [17] Hanley, S. (2018). How the EPA rates an electric car. Clean Technica, 5th December 2018. <https://cleantechnica.com/2018/12/05/how-the-epa-rates-an-electric-car/> (last accessed: 27 August 2020)
- [18] Pushevs (2016). WLTP and electric cars. <https://pushevs.com/2016/10/13/wltp-electric-cars/> (last accessed: 28 August 2020)
- [19] Pushevs (2020). Electric car range efficiency (NEDC). <https://pushevs.com/electric-car-range-efficiency-nedc/> (last accessed 20 August 2020)
- [20] Association for Emissions Control by Catalyst (AECC) (2020). Real-driving emissions. <https://www.aecc.eu/key-topics/real-driving-emissions/> (last accessed 20 August 2020)
- [21] Statistic sentralbyrå – Statistics Norway (2020). Electricity prices, updated 18 August 2020. <https://www.ssb.no/en/energi-og-industri/statistikker/elkraftpris> (last accessed 28 August 2020)





- [22] <https://www.nve.no/reguleringsmyndigheten-for-energi-rme-marked-og-monopol/nettjenester/nettleie/nettleiestatistikk/nettleiestatistikk-for-naeringskunder/>, Published 03.03.2015, last updated 23.02.2017
- [23] Anesen, T., Still high electricity prices for households, Statistics Norway, published on 22 November 2018. Available at: <https://www.ssb.no/en/energi-og-industri/artikler-og-publikasjoner/still-high-electricity-prices-for-households>
- [24] Statista, “Prices of electricity for industrial use in Norway from 1995 to 2018”, with additional information “Norway: industrial prices electricity 1995-2018 by N. Sönnichsen, 5 February 2020. Available at: <https://www.statista.com/statistics/595859/electricity-industry-price-norway/>
- [25] Brenna, A. L., “The power link is calculated according to the highest energy consumption within one hour per month”, energiWEBINAR.NO (enerWE), Google translation from the Norwegian original, Accessed at: <https://translate.google.com/translate?hl=en&sl=no&u=https://enerwe.no/a/336580&prev=search>
- [26] Hovland, K.M., “Bygger kraftlinjer for 140 mrd, E24 NO, updated on the 26th of March 2017, published on the 10th of January 2017, <https://e24.no/energi/fornybar-energi/bygger-kraftlinjer-for-140-mrd/23894217>
- [27] Hildermeier, J., Kolokathis, C., Rosenow, J., Hogan, H., Wiese, C. and Jahn, A., Start with smart. Promising practices for integrating electric vehicles into the grid. Brussels, Belgium: Regulatory Assistance Project, 2019. Available at: <https://www.raponline.org/wp-content/uploads/2019/03/rap-start-with-smart-ev-integration-policies-2019-april-final.pdf>
- [28] Gudbrann Hempel, O. (Head of Public Charging Service, Fortum Charge & Drive Norway), “Fortum Charge & Drive - learnings from the First E-mobility Mass market Norway”, https://static1.squarespace.com/static/5beeb85155b02c87c213e1c6/t/5c6570eb971a187c66374a35/1550151945024/Fortum_EspenSkaar_OleGudbrannHempel_LearningsEmobilityMassMarket.pdf, no date.
- [29] Breitschopf, B., Grave, K and Bourgault, C., Electricity costs of energy-intensive industries in Norway. A comparison with energy-intensive-industries in selected countries. Project report. Karlsruhe / Berlin: Fraunhofer Institute for Systems and Innovation Research and Ecofys GmbH, 2016. Available at: <https://www.energinorge.no/contentassets/525e77b1feff4203a94ef6d1f94cfd03/electricity-costs-of-energy-intensive-industries-in-norway.pdf>
- [30] Bjelland Eriksen, A., Regulatory experiences: From volumetric- to capacity-based tariffs. NVE. Presentation at the CEER Workshop on network tariffs –October 19th 2018. PowerPointPresentation available at: <https://www.ceer.eu/documents/104400/-/-/9ad78f1a-c528-289a-a213-6a8f95c9d51f>
- [31] Energy Facts Norway and Ministry of Petroleum and Energy, “The Power Market”. No date but says “the content is based on the facts booklet that was published until 2015. Available at: <https://energifaktanorge.no/en/norsk-energiforsyning/kraftmarkedet/>
- [32] Figenbaum, E. and Kolbenstvedt, M., Learning from Norwegian Battery Electric and Plug-in Hybrid Vehicle users. Results from a survey of vehicle owners. Report nr. 1492/2016. Oslo: Institute of Transport Economics, 2016. Available at: <https://www.toi.no/publications/learning-from-norwegian-battery-electric-and-plug-in-hybrid-vehicle-users-results-from-a-survey-of-vehicle-owners-article33869-29.html>
- [33] Julsrud, T.E., Figenbaum, E., Nordbakke, S. Denstadli, J.M., Tilset, H., and Schiefloe, P.M., Pathways to Sustainable Transport among Norwegian Crafts and Service Workers. Report 1503/2016. Oslo: Institute of Transport Economics, 2016. Available at: <https://www.toi.no/publications/pathways-to-sustainable-transport-among-norwegian-crafts-and-service-workers-article34019-29.html>
- [34] Aarestrup Aasness, M. and Odeck, J., ‘The increase of electric vehicle usage in Norway—incentives and adverse effects’. European Transport Research Review, Vol. 7(34), pp. 1-8, 2015.
- [35] Figenbaum, E., ‘Perspectives on Norway’s supercharged electric vehicle policy’. Environmental Innovation and Societal Transitions, Vol. 25, pp. 14-34, 2016.
- [36] Figenbaum, E., Assum, T. and Kolbenstvedt, M., Electromobility in Norway: Experiences and Opportunities. Research in Transportation Economics, Vol. 50, pp. 29-38, 2015.
- [37] Sørensen, A.L., Sartori, I. and Andresen, I., ‘Smart EV Charging Systems to Improve Energy Flexibility of Zero Emission Neighbourhoods. A state of the art for Norway’. In: Johansson D., Bagge H., Wahlström Å. (eds) Cold Climate HVAC 2018. CCC 2018. Springer Proceedings in Energy. Springer, Cham. Public post-print version available at: https://ntnuopen.ntnu.no/ntnu-xmli/bitstream/handle/11250/2594064/S%25C3%25B8rensen_%25C3%2585se_EV_smart_charging%2b-%2bPostPrint.pdf?sequence=2&isAllowed=y





- [38] Centre for Public Impact (a BCG Foundation), “Case Study: The rise of electric vehicles”, 8 April 2014, Available at: <https://www.centreforpublicimpact.org/case-study/electric-cars-norway/>
- [39] Robb, J. (Segment Manager Commercial and Industrial Buildings, EMEA Eaton), “White Paper: Making Stadiums and Arenas more resilient and energy efficient”, Eaton Xstorage, February 2019. Available at: <https://www.eaton.com/content/dam/eaton/markets/buildings/resiliency/documents/xstorage-peak-shaving-whitepaper.pdf>
- [40] Figenaum, E., ‘Norway – the world leader in BEV adoption’. In: Contestable, M, Tal, G. and Turrentine, T. (eds) Who’s Driving Electric Cars. Understanding Consumer Adoption and Use of Plug-in Electric Cars, pp. 89-210. Springer. Cham: Springer International.



Appendix A

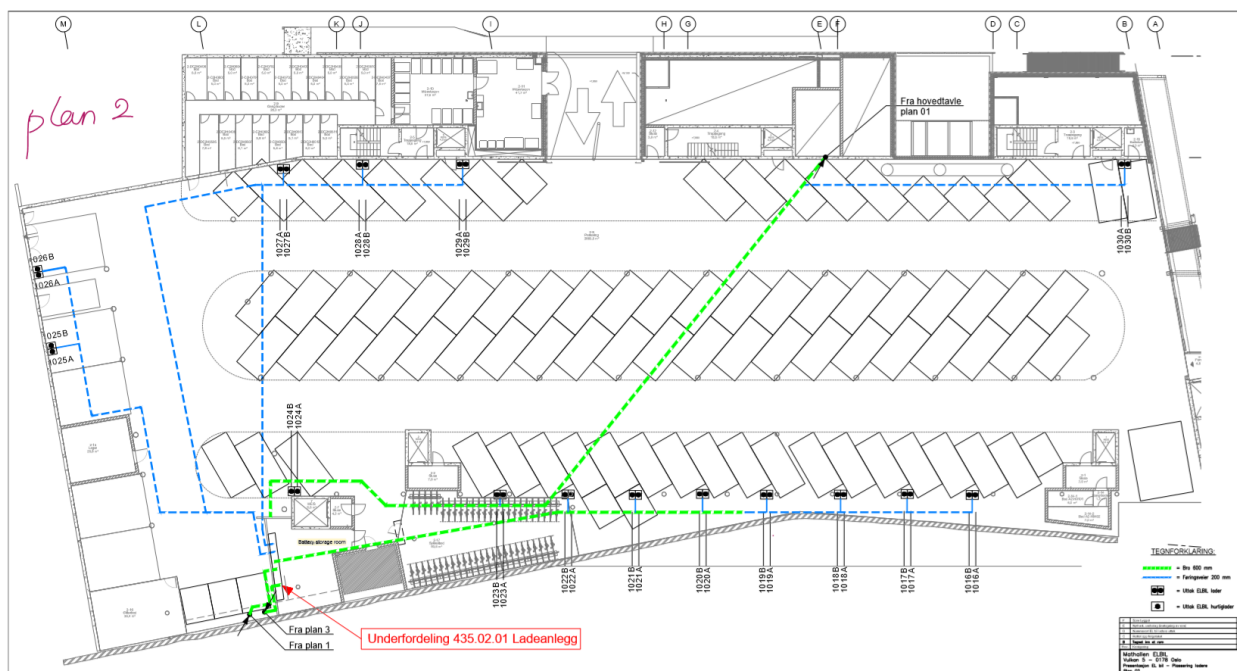

Figure A1: The detailed schematic of the power distribution network for floor 2 of the parking garage.

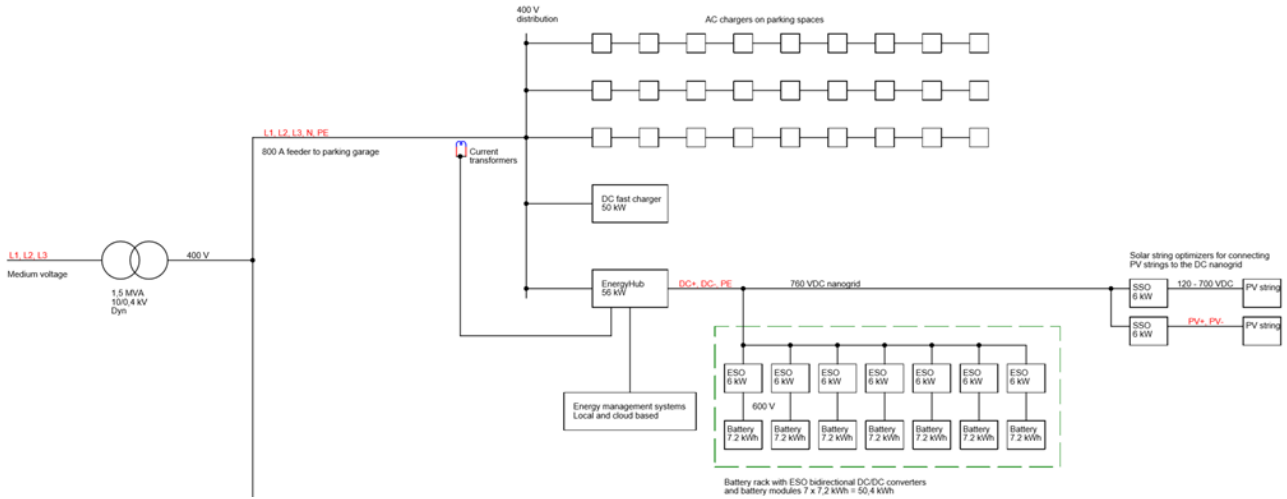

Figure A2: A diagram of the original plan of the power distribution network (this is the original version of Figure 6, which at the time included a PV system which was in the end not implemented)