

Development of Guiding Cane with Voice Notification for Visually Impaired individuals

Emeline C. Guevarra, Marck Ivan Reyes Camama, Geonel Villanueva Cruzado

Department of Computer and Electronics Engineering, College of Engineering and Information Technology,
Cavite State University, Indang Cavite, 4122 Philippines

Article Info

Article history:

Received Mar 2, 2017

Revised Sep 14, 2017

Accepted Sep 28, 2017

Keyword:

Audio notifications

Gizduino

Microcontroller

Ultrasonic sensors

Voice kit II

ABSTRACT

Navigation in the physical environment is a challenge for those people who have very limited sense of sight or no vision at all. Assistive technologies for blind mobilization is not new and always have a room for improvement. Moreover, these assistive devices are limited in terms of its sensing and feedback abilities. This paper presents a microcontroller-based guiding stick capable of detecting several conditions of the environment such as obstacles in front, left and right positions of the user and detects ascending and descending staircases. The feedback is delivered by an audio output which dictates the direction to go or what condition the sensor detects in front of the user. Technical evaluation proves that the device was functional in terms of its accuracy, responsiveness and correctness. On the other hand, in the actual evaluation of the device with the visually impaired individuals, the device did not perform efficiently. It was also found that the device has the potential to be used effectively by the visually impaired who acquired their blindness in later stage of their life provided that they will have a proper training in using the device while navigating in the physical environment.

Copyright © 2018 Institute of Advanced Engineering and Science.
All rights reserved.

Corresponding Author:

Emeline C. Guevarra,
Department of Computer and Electronics Engineering,
Cavite State University,
Barangay Bancod, Indang, Cavite, 4122, Philippines.
Email: ecguevarra@cvsu.edu.ph

1. INTRODUCTION

Updating position and orientation is a significant role of vision as well as identifying objects a person is approaching but for those with no vision or limited sense of sight, navigating through the world can be a challenge. The visually impaired must rely on senses other than sight such as hearing and touch to guide them. Visually impaired persons rely on the traditional cane for the ease of navigation through the surroundings. By means of a cane or a guide dog, visually impaired person can avoid obstacles that are approaching nearby, avoid drop-offs or pitfalls and be able to climb up and down the stairs.

There have been many proposed assistive devices for the visually impaired. The major differences between the devices are where they are mounted or worn, how feedback is delivered, and how the surroundings are detected. Since then, these innovations have always a room for improvement [1]. An electronic blind guiding stick was developed that uses ultrasonic sensors which are mounted on the handle rod controlled by a single-chip microcomputer that limits its sensing in front obstacles and does not address the needs of the visually impaired in terms of climbing up and climbing down a staircase. The feedback is delivered by a voice pattern [2]. Other studies addressed also the obstacle above the head of the user and uses vibratory patterns as a feedback and sound alarm in form of beeps. Additional features are added in these devices such as GPS integration [3], Bluetooth wireless communication to user and device and RFID tags integration which is very specific to places like indoors. Some of these developments are usually wired and

therefore inconvenient to the user part thus can be minimize if the interfacing of the parts of the system such as the sensing and feedback unit are wireless [4-8]. An assistive device in a form also of a guiding stick was also developed based on image identification embedded with road condition subsystem, navigation subsystem and a roller braking system. The feedback of the device comes from the bluetooth headset [9]. All of these developments has its advantages and also had its limitations. Most of these developments does not cater the over-all needs of the visually impaired while navigating in the physical environment. Some of these technologies required a learning curve for the user to be able to use effectively and efficiently the device. Design considerations with these portable devices should be lightweight, compact and can easily be carried but not worn [10].

In order for the visually-impaired to navigate freely in the environment, the researchers developed a Microcontroller-Based assistive device that is in the form of a guiding stick which can sense the surroundings through a sensor and relay that information to the device user through an audio output by utilizing radio frequency. The device is capable of detecting several conditions of the environment such as obstacles in front, left and right positions of the user and detects ascending and descending staircases. The feedback is delivered by an audio output which dictates the direction to go or what condition the sensor detects in front of the user. This system comes in one package that addresses what the blinds really needs in navigating the external environment at a minimal cost compared to other systems.

2. RESEARCH METHOD

Microcontroller-based guiding stick consists of the following electronic components integrated to form a system that can perform the required operations: Gizduino ATmega 328P [11] as the microcontroller board, an array of ultrasonic sensors positioned in different parts of the standard quad-cane for sensing operations, FM broadcaster [12], voice kit II [13] where the audio notifications are stored and a vibration motor as an additional feedback to the user whenever there is a presence of depth 10 inches above.

2.1. Design and Modification of Standard Quad-cane

The adjustable quad cane was fixed at 34 inches based on the standard height of a walking stick [14]. Caster wheels were attached and welded at the base end of the quad cane for the easy maneuvering of the device by the user. Three ultrasonic sensors with custom housing were attached at the upper part of the cane at an angle of 60 degrees. Each three sensors are oriented in left, right and front accordingly. On the middle part of the cane, one ultrasonic sensor is placed with its custom case; this is for the detection of the inclined staircase and mid-level obstacles. Figure 1 shows the physical specifications of the device.

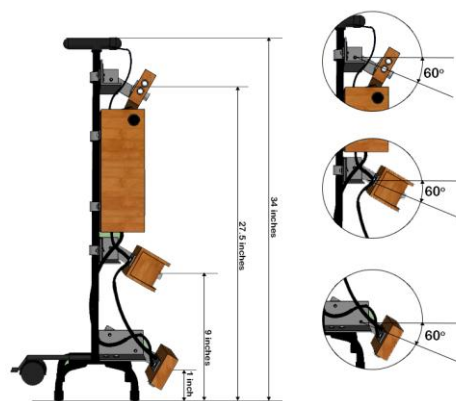

Figure 1. Physical specifications of the device and its measurements

2.2. Integration of the Microcontroller, Ultrasonic Sensors, Voice kit II, FM Broadcaster and Vibration Motor

The device is comprised of six inputs which is composed of six ultrasonic sensors, a voice kit and a vibration motor for the output. Ten pins were utilized for the device input and output. Before the voice kit was integrated with the microcontroller, the recorded voice was stored in 9 individual memory addresses of the voice kit by means of Universal Serial Bus to Universal Asynchronous Receiver/Transmitter (UART) converter. Since there are components of the system that requires higher voltage for it to work, the DC-DC

[15] converter was utilized. Digital pins D2 and D3 of the microcontroller were used for the RX and TX pins of the voice kit. This is for the serial communication between the voice kit and the microcontroller.

To enable the wireless connection between the Radio Frequency wireless headset and the guiding stick, Frequency Modulation broadcaster was used. FM was tuned at 98.0 megahertz (MHz) frequency band as well as the RF headset. Figure 2 shows the schematic diagram of the system.

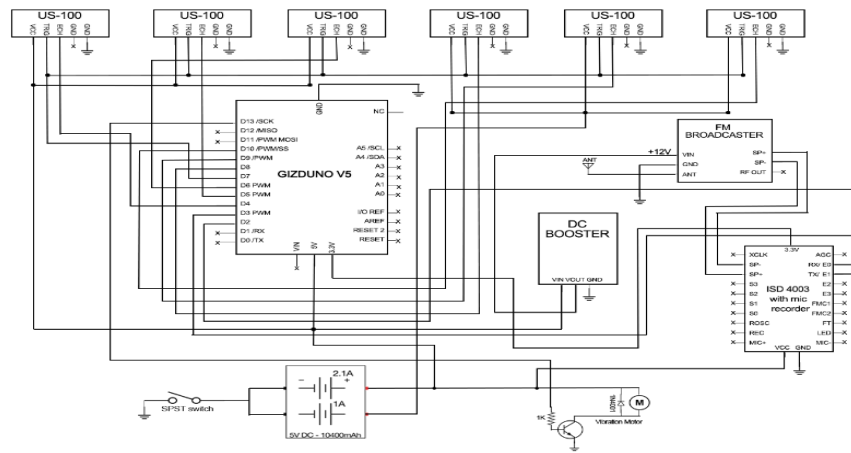

Figure 2. The system schematic diagram

2.3. System Development

The control unit was programmed using Arduino [16] software which is an Integrated Development Environment. The device software algorithm was implemented according to what the sensor senses in certain directions and distance covered by the sensor. Figure 3 shows the system flowchart of the Microcontroller-based Guiding Stick.

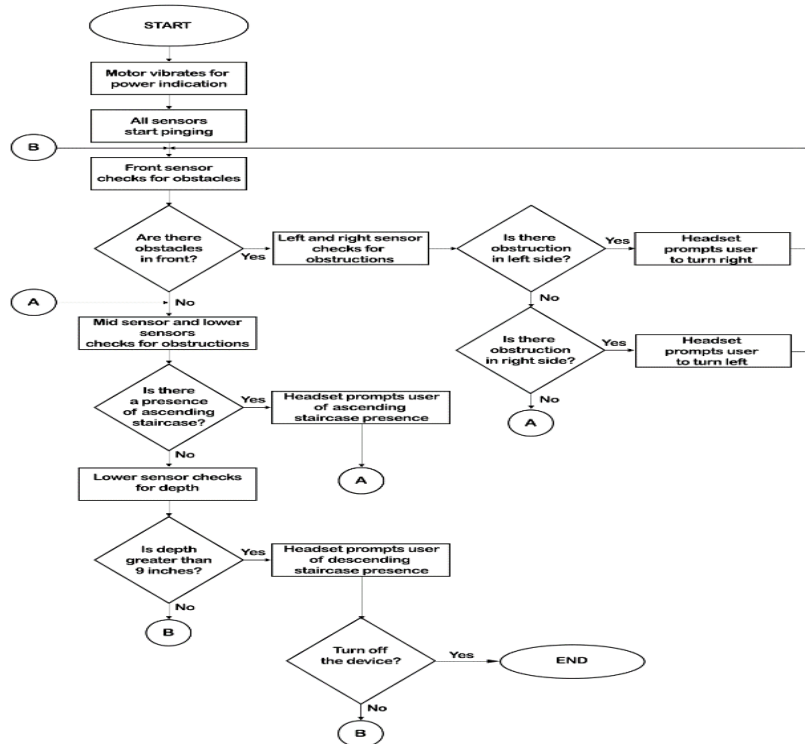

Figure 3. System flowchart of the design

2.4. Testing and Evaluation

To ensure that the project was working, a series of tests were done. The system was tested in an actual situation. The researchers used a black-box testing technique[17] where the output was analyzed through a series of inputs. It includes two major parts: functional testing that was concerned with what the system does; its features or functions; and non-functional testing that focuses on user-acceptability. Thus, it was evaluated through user acceptability and technical evaluations. In acceptability test, the operability or user interaction, reliability, accuracy, functionality, safety and usability was evaluated by the intended subjects by testing the device in a simulated environment for safety purposes.

For the technical evaluation, a series of test in each sensor were done by the researchers. For accuracy, the minimum and maximum distances of the sensors were determined. Responsiveness of the feedback which is consisted of five trials were tested by measuring the delay of the audio feedback when the sensors were in specific obstacle condition. Correctness of the feedback was determined whether the sensor responded correctly in the correct direction where the user should go. This was done by using the device in the actual maze that can be seen in Figure 4 and determining if the feedback gives the correct direction and condition.

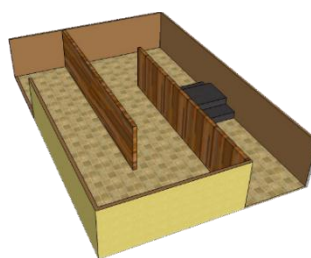

Figure 4. Maze layout for testing and evaluation

Before the device was evaluated by the visually impaired, it was tested first by the Ethics Review Board. To validate the functionality of the device with the intended subjects, the evaluation is consisted of three trials in which six visually impaired were the participants. The obstacle course was designed for subjects to navigate through with the device. The starting point was randomized in each trial to help reduce any learning effect of the different courses. For sloping stairway and drop-offs, a 3 step customized wooden staircase was constructed and was place inside the maze. Each trial was timed until they reached the end of the course. If the subject did not reach the finish line, then the trial will be marked as F, meaning an unsuccessful or failed trial and S otherwise. Collisions were counted as every time a participant touched or made any contact with a wall or objects. To evaluate the parameters stated in this study as for the user acceptance, a validated survey questionnaire/interview guide was administered to the subjects after using the device in the simulated environment.

3. RESULTS AND ANALYSIS

This section presents the analysis and interpretation of data gathered from the test and evaluation performed with the view of having the objectives of this research work be performed. This also includes the presentation of the actual device.

3.1. Principle of Operation

The device can be opened by pressing the rocker switch in the right side of the circuit compartment. A vibration coming from the vibration motor will be felt by the user after the device initialized. The Radio Frequency wireless headphone can be turned on by pressing the power button on its left side and setting it to the radio mode. The frequency will be automatically detected for the audio feedback.

The maximum angle that the device can tolerate is up to 70 deg. from the ground when the user tilts the cane. This is achieved by putting a stopper in the lower base part of the cane where the caster wheel is attached. Figure 5 presents the complete system of the microcontroller-based guiding stick.



Figure 5. The microcontroller-based guiding stick – front view and right side view

3.2. Technical Evaluation

The microcontroller-based guiding stick was technically evaluated first before proceeding in the actual evaluation for the intended subjects to determine its performance. As for the microcontroller, it requires a supply of 5 to 12 volts. This is where the voice kit II, ultrasonic sensors and vibration motor were interfaced. A total of 180 mA was consumed by the digital pins in the microcontroller. The system utilizes a wireless communication between the Radio Frequency wireless headphone and the device itself. FM broadcaster on the other hand draws a 350 mA when used in wireless mode. From this it can be computed that the battery, with 10000 mAh capacity, may last more than 13.5 hours.

As for the weight of the guiding stick, due to the materials used in the circuit compartment and the big capacity of the battery, the device weighed 2.8 kg. The maximum angle that is tolerable by the cane when tilted is up to 60 to 70 deg. for effective detection of obstacles.

For the accuracy of the sensors, to compute for the percent error, the experimental distance and actual distance was subtracted and was divided by the experimental distance then was multiplied by 100.

$$\text{Percent Error} = \left| \frac{\text{Experimental distance} - \text{Actual distance}}{\text{Experimental distance}} \right| \times 100$$

Table 1 presents the summary of the data gathered in terms of the accuracy of each individual sensor.

Table 1. Summarized data of accuracy of individual sensors

Sensor Placement	Accuracy (%)
Upper front	95.53
Left	96.12
Right	95.25
Mid-front	94.75
Lower-front	90.34
Lower-base	89.64

To evaluate the responsiveness of the feedback, the delay of the audio feedback was measured. The distance also was set according to the program. Table 2 shows the responsiveness of feedback at certain conditions in the environment.

In evaluating the correctness of feedback, the device was evaluated in the actual maze. The researchers traveled and completed the maze and determined if the feedback is correct. The maze is consisted of nine obstacles and numbered from 1 to 9. Table 3 shows the summarized results in evaluating the correctness of feedback of the device. Results showed that the device performed correctly in most of the trials.

Table 2. Responsiveness of feedback in certain conditions

CONDITION	TRIAL 1 (s)	TRIAL 2 (s)	TRIAL 3 (s)	TRIAL 4 (s)	TRIAL 5 (s)	AVERAGE (s)
Front and right obstacle	2.39	1.69	1.20	1.93	1.39	1.72
Front and left obstacle	1.82	1.62	1.11	2.37	1.54	1.70
Deadend	1.23	1.52	1.62	2.14	1.84	1.67
Ascending staircase	3.66	1.93	1.32	2.45	2.15	2.30
Descending staircase	1.6	0.67	3.05	2.90	1.33	1.93

Table 3. Correctness of feedback

OBSTACLE NUMBER	TRIAL 1	TRIAL 2	TRIAL 3
1	✓	✗	✓
2	✓	✓	✓
3	✓	✓	✓
4	✓	✓	✓
5	✓	✓	✓
6	✓	✗	✓
7	✓	✓	✓
8	✓	✓	✓
9	✓	✓	✓
Total	9	7	9
AVERAGE			8.33

3.3. Actual Evaluation

The device was evaluated by the visually impaired by travelling and completing the maze set and constructed by the researchers in the evaluation place in which starting point is randomized and numbered. Figure 6 shows the 3 maze layouts in which each obstacle are numbered.

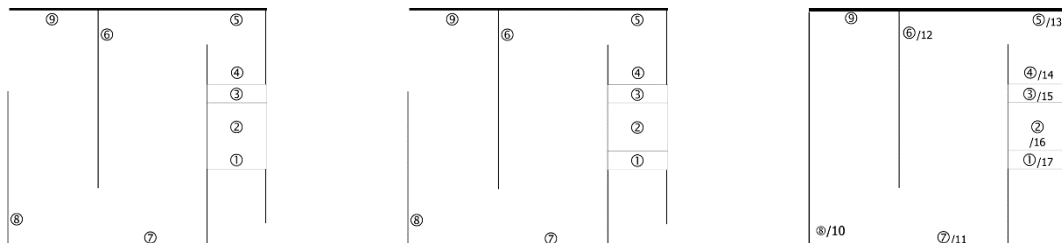

Figure 6. Maze layout for trial 1(left), maze layout for trial 2 (middle) and maze layout for trial 3 (right)

Each participant was given 3 trials. Demographics of the participants were also considered in evaluating the device. Given that the demographics is not consistent and varies, each of the perception of the participants also varies. This has affected the user acceptance and the way the participant used the device. The population sample is consisted of three males and three females. The participants were classified into two categories: congenitally blind subjects who were blind since birth or became blind at young age when they were not able to master spatial orientation and mobility skills; and subjects that acquired blindness at later stage in their life. Subjects 1, 2, 4, and 5 were considered congenitally blind and subjects 3 and 6 were considered as participants who acquired blindness in their later stage of life.

Table 4 shows the summarized results of the data gathered regarding the total number of collisions encountered by the participants, total number of correct turns in obstacles encountered and total number of successful completion of maze in all trials, each is classified according to two categories which is the nature of blindness of the participants. It can be inferred from the results that the participants who had acquired blindness experienced least number of collisions and mostly the ones who successfully completed the maze in the time limit that was set.

Therefore, it can be concluded that the device can be used effectively for the participants or individuals who acquire blindness in later stage of their life if they will be trained properly in using the

device. This is because they have already experience navigating in the physical environment and had mastered mobility skills, spatial orientation and the point of reference when navigating.

Table 4. Summarized results of the data gathered in actual evaluation

NATURE OF BLINDNESS	SUBJECT NUMBER	TOTAL NUMBER OF CORRECT TURNS IN 3 TRIALS	TOTAL NUMBER OF COLLISIONS IN 3 TRIALS	TOTAL NUMBER OF SUCCESS COMPLETION OF MAZE
Congenital	1	11	51	1
	2	19	30	2
	4	14	38	2
	5	3	59	0
Acquired	3	11	28	2
	6	12	31	2

Table 5 shows the summarized results in the three trials in the evaluation by PWDs. Overall results showed that the device did not perform efficiently and therefore the blind have experienced so many collisions when travelling in the maze. Some of the factors exhibited by the participants had affected the results like the unfamiliarity of one user in spatial orientation, experience of cane usage, demographic factor, user speed and the proper inclination of the device when in use. This implies that for the user to use the device effectively, the user needs a proper training.

Table 5. Summarized results in 3 trials

TRIAL	RESULTS
1	Successful
2	Failed
3	Failed
REMARKS	NOT EFFICIENT

The operability, reliability, accuracy, functionality usability and safety data were gathered. A questionnaire was administered to the persons with disabilities after completing the three trials in the maze. Table 6 shows the rating used to interpret the data acquired in the questionnaires answered by the participants.

Table 6. Reference for rating the parameters: operability, reliability, accuracy, functionality usability and safety

RATING	DESCRIPTION
4.21-5.00	Excellent - The device met the said indicator and exceed the user expectations.
3.41-4.20	Satisfactory - The device met the said indicator and the user expectations.
2.61-3.40	Fair - The device met the said indicator but encounter little problems.
1.81-2.60	Needs Improvement - The device system somehow met the said indicator but encountered delays and errors
1.00-1.80	Poor - The device did not met the said indicator

Table 7 shows the summarized data based on the user acceptability of the device. The mean and standard deviation evaluated by persons with disability were combined.

Table 7. Summarized user acceptability computations

PARAMETERS	MEAN	STANDARD DEVIATION
Operability	4.44	0.57
Reliability	3.33	0.41
Accuracy	3.27	0.88
Functionality	4.33	0.92
Usability	4.20	0.92
Safety	4.58	0.52

4. CONCLUSION

Through technical evaluation, it is concluded that the guiding stick was functional and can be used for navigation. Through the actual evaluation of the device, the device was not considered efficient and does not perform reliably while using it in the simulated environment by the intended participants. This is because of the factors that have affected the performance of the device like failure of some participants in direction comprehension, experience of cane usage, proper inclination of the device when in use, demographic profile and the user speed. It was also found that the device has the potential to be used effectively by the visually impaired who acquired their blindness in later stage of their life provided that they will have a proper training in using the device while navigating in the physical environment. These factors therefore affect the results of the evaluation and found that for the device to perform efficiently, the user needs proper training in using the device.

ACKNOWLEDGEMENTS

The authors would like to acknowledge Cavite State University RECETS for funding the publication of this journal.

REFERENCES

- [1] Curham K. & Wolfe A, "Navigation Using a Haptic Hand-Mounted Device for the Visually Impaired," Presentation presented at; 2012; University of South Florida.
- [2] Zhao C, Wenjin H, Li K, Xiao S, "Electronic Blind Guiding-Stick," European; CN203935390 (U), 2014.
- [3] Pooja Velaskar, Alvaro Vargas-Clara, Osama Jameel, Sangram Redkar, "Guided Navigation Control of an Unmanned Ground Vehicle using Global Positioning Systems and Inertial Navigation Systems," *International Journal of Electrical and Computer Engineering (IJECE)* Vol. 4, (3), pp. 329-342, June 2014.
- [4] Zhang F, "Electronic navigation blind-guiding stick," European; CN202366117 (U), 2011.
- [5] Miguel Hernandez, "Electronic Cane for Assisting with Mobility of Visually Impaired People," European; ES2441670, 2014.
- [6] University of Beihang, "Intelligent blind guiding stick based on image identification," European; CN103637900, 2014.
- [7] Railway Technical Res Inst, "Leading Guiding System for Visually-Impaired," Chinese; 4396891, 2005.
- [8] Wakhyu Dwiono, "Siska Novita Posma, Arif Gunawan. Embedded System Application for Blind People Navigation Tool," *TELKOMNIKA (Telecommunication Computing Electronics and Control)*, Vol. 12, (8), pp. 6083 – 6087, August 2014.
- [9] Cheng Jan C, Ren-Chyuan L, Chun-Chi L, "Electronic Blind-Navigation Device and Electronic Blind-Navigation Cane," Chinese; 20110054773, 2011.
- [10] Boggarapu Kantha Rao, Dasari Ramesh, Jarpula Rajini Bai, "Blind Visually Impaired & Wearable Equipment Wearable System Using Physical and Sensory Disabilities," *International Journal on Scientific Engineering and Research*, Vol.04 (13), pp. 2435-2439, May 2015.
- [11] e-Gizmo GizDuino ATmega328P version5 [Internet]. E-gizmo.com. 2015 [cited 23 August 2015]. Available from: <http://www.e-gizmo.com/KIT/gizduinov.html>
- [12] e-Gizmo Personal FM Broadcaster [Internet]. E-gizmo.com. 2012 [cited 23 August 2015]. Available from: <http://www.e-gizmo.com/KIT/FM%20Broadcaster.htm>
- [13] e-Gizmo Voice kit 2 [Internet]. E-gizmo.com. 2017 [cited 24 August 2015]. Available from: <http://www.e-gizmo.com/KIT/voicekit2.html>
- [14] How to Size a Walking Stick | Top & Derby [Internet]. Top & Derby. 2017 [cited 24 August 2015]. Available from: <https://www.topandderby.com/pages/sizing>
- [15] e-Gizmo Positive DC DC Converter [Internet]. E-gizmo.com. 2017 [cited 23 August 2015]. Available from: <http://www.e-gizmo.com/KIT/POSITIVE%20DC%20DC.html>
- [16] Arduino - Software [Internet]. Arduino.cc. 2017 [cited 23 August 2015]. Available from: <https://www.arduino.cc/en/main/software>.
- [17] Laurie W. Testing Overview and Black-Box Testing Techniques [Internet]. 1st ed. Realsearchgroup.com; 2006 [cited 20 July 2015]. Available from: <http://agile.csc.ncsu.edu/SEMaterials/BlackBox.pdf>.

BIOGRAPHIES OF AUTHORS

Emeline C. Guevarra is an Assistant Professor II in College of Engineering and Information Technology – Department of Computer and Electronics Engineering at Cavite State University, Indang, Cavite. She received her BS degree in Computer Engineering from Polytechnic University of the Philippines in 1997. She obtained her MS degree in Electrical Engineering major in Computer Engineering at Technological University of the Philippines Manila in 2011 and obtained 48 units for Doctor of Technology in the same school thereafter. Her research interest anchors in Network Design and Implementation.



Marck Ivan R. Camama finished his Bachelor's degree in Computer Engineering in May 2017 in Department of Computer and Electronics Engineering at Cavite State University – Don Severino Delas Alas Campus, Indang, Cavite. His research interests are in areas of internet of things, software engineering, instrumentation and networks.



Geonel V. Cruzado completed his Bachelors degree in Computer Engineering in December 2016 in Department of Computer and Electronics Engineering at Cavite State University – Don Severino Delas Alas Campus, Indang, Cavite. His research interests are in the areas of electronics, networks and signal processing.