

## Simulation and Implementation of a High Performance Torque Control Scheme of IM Utilizing FPGA

R. Rajendran\*, N. Devarajan\*\*

\*Karpagam College of Engineering Coimbatore, India

\*\*Government College of Technology Coimbatore, India

---

### Article Info

#### Article history:

Received Dec 12<sup>th</sup>, 2011

Revised Mar 11<sup>th</sup>, 2012

Accepted Mar 26<sup>th</sup>, 2012

---

#### Keyword:

Induction Motor

DTC

DTC-SVM

FPGA

Matlab/Simulink

Xilinx System Generator

---

### ABSTRACT

This paper presents a novel approach to design and implementation of a high performance torque control scheme i.e. direct torque control with space vector modulation (DTC-SVM) of three phase induction motor using Field Programmable gate array (FPGA). The conventional direct torque control (DTC) is one of control scheme that is used commonly in induction motor control system. This method supports a very quick and precise torque response. However, the conventional DTC is not perfect and has some disadvantages. To minimize the ripples of the electromagnetic torque and flux linkage and to fix the variable switching frequency produced in the conventional DTC, this paper proposes improved DTC-SVM concept. Both simulation and experimental results show that the proposed scheme can dramatically improve the steady state performance while preserving the dynamic performance of the conventional DTC.

Copyright © 2012 Institute of Advanced Engineering and Science.  
All rights reserved.

---

### Corresponding Author:

R. Rajendran,

Karpagam College of Engineering Coimbatore, India

Email: raja\_mein@yahoo.co.in

---

## 1. INTRODUCTION

Induction Motors (IMs) have been widely used in industry because of their advantages: simple structure, ruggedness, high reliability, low cost and minimum maintenance. In recent years, the development of high performance control strategies for induction motor drives resulted in a rapid evolution. One of the most popular methods, known as direct torque control (DTC), has been proposed by Tahahashi in the middle of 1980s[1]. DTC provides very quick response with simple control structure and hence this technique is gained popularity in industrial process, commercial, domestic and automobile applications [2]-[3]. Through conventional DTC has high dynamic performance, it has few drawbacks such as high ripple in torque, flux and current and variation in switching frequency of the inverter. The effects of flux and torque hysteresis band amplitudes in the induction motor drive performance have been analyzed in [4]. To improve the performance of conventional DTC in terms of ripple, discrete space vector modulation (DSVM) technique was proposed in [5]. But the conventional DTC and DSVM based DTC give the variation in switching frequency. The problem of variation of switching frequency can be overcome by using space vector pulse width modulation (SVPWM) [6]-[7]. In this method for each sampling period, voltage space vectors have been generated and are used for the reduction of flux and torque ripples[8]-[10].

In practice, the vector control algorithm for an induction motor is implemented utilizing digital signal processor (DSP), which is superior in their ability to handle calculations. The DSP control procedure is performed sequentially, exploiting mathematically oriented resources. This may result in a slower cycling period if complex algorithms are involved. Employing field programmable gate array (FPGA) in implementing vector control strategies provides advantages such as rapid prototyping, simpler hardware and software design, high speed computation and hence fast switching frequency. In contrast, FPGA performs entire procedure with concurrent operation (parallel processing via hardware) using reconfigurable hardware.

For its powerful computation ability and flexibility, the FPGA may be the best solution to achieve excellent performance in ac drive system [11]-[18].

This paper presents a novel approach to the design and implementation of high performance SVPWM based DTC strategy of an induction motor drive. This strategy is designed using Xilinx System Generator (XSG) and Matlab/Simulink software packages and implemented on FPGA controller. The validity of this design method is verified by the experimental results of an induction motor drive system.

## 2. IM MODEL

The following equations written in terms of space voltage vector in a stationary reference frame describe the dynamic behavior of an induction motor

$$v_s = R_s i_s + \frac{d\lambda_s}{dt} \quad (1)$$

$$0 = R_r i_r + \frac{d\lambda_r}{dt} - j\omega_r \lambda_r \quad (2)$$

$$\lambda_s = L_s i_s + L_m i_r \quad (3)$$

$$\lambda_r = L_r i_r + L_m i_s \quad (4)$$

where  $v_s = [v_{ds} \quad u_{ds}]^T$  is space vector of stator voltage,  $\lambda_s = [\lambda_{ds} \quad \lambda_{qs}]^T$  and  $\lambda_r = [\lambda_{dr} \quad \lambda_{qr}]^T$  are respectively the stator and rotor flux vectors,  $i_s = [i_{ds} \quad i_{qs}]^T$  and  $i_r = [i_{dr} \quad i_{qr}]^T$  are respectively the stator and rotor current vectors.

( $R_s, R_r$ ) and ( $L_s, L_r$ ) are respectively the stator and rotor resistances and inductances,  $L_m$  is mutual inductance,  $\omega_r$  is motor angular speed in electrical rad/sec.

Also, the motor mechanical equation is

$$\frac{d}{dt} \omega_m = \frac{T_e}{J_m} - \frac{T_l}{J_m} - \frac{B_f}{J_m} \omega_m \quad (5)$$

where  $T_{eref}$  is the motor electromagnetic developed torque which is defined by:

$$T_e = \frac{3P}{2} (\lambda_{ds} i_{qs} - \lambda_{qs} i_{ds}) \quad (6)$$

## 3. PROPOSED SVM-DTC

On the subject of the DTC-SVM with closed-loop torque control, its control objective is to select the exact stator voltage vector,  $v_s$  that changes  $\Psi_s$  to meet the load angle reference, and so the desired torque while keeping flux amplitude constant. A space vector modulation algorithm is used to apply the required stator voltage vector. It is expected that torque ripple is almost eliminated, while zero steady state error is achieved with fixed switching frequency[3]. The stator flux can be directly obtained from the motor model equation as follows:

$$\hat{\Psi}_s = \int (V_s - R_s I_s) dt \quad (7)$$

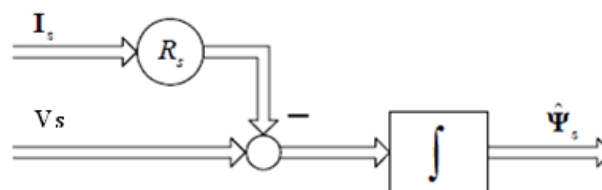

Figure 1. Voltage model based estimator with pure integrator

Figure 1 is a classical voltage model of stator flux vector estimation, which obtains flux by integrating the motor back EMF. The block diagram of this estimator is shown in Figure This method is sensitive for only one motor parameter, stator resistance. However, the implementation of pure integrator is difficult because of dc drift and initial value problems. In order to eliminate these problems the authors proposed a new flux estimator with low pass filter as shown in Figure 2, which eliminates problems with initial conditions and dc drift, which appear in pure integrator. In this case the equation can be transformed as follows:

$$\frac{d\hat{\Psi}_s}{dt} = (\hat{V}_s - R_s I_s) - \frac{1}{T_F} \hat{\Psi}_s \tag{8}$$

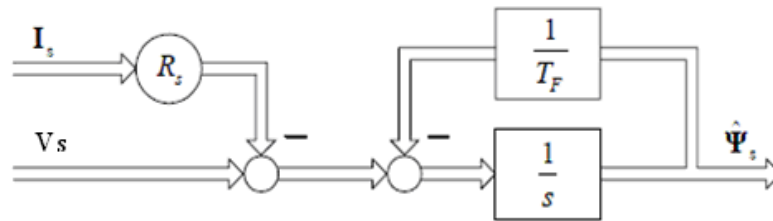

Figure 2. Flux estimator based on voltage model with low pass filter

The block diagram of the method with low pass filter is presented in Figure 3. The estimator stabilization time depends on the low-pass filter time constant  $T_F$ .

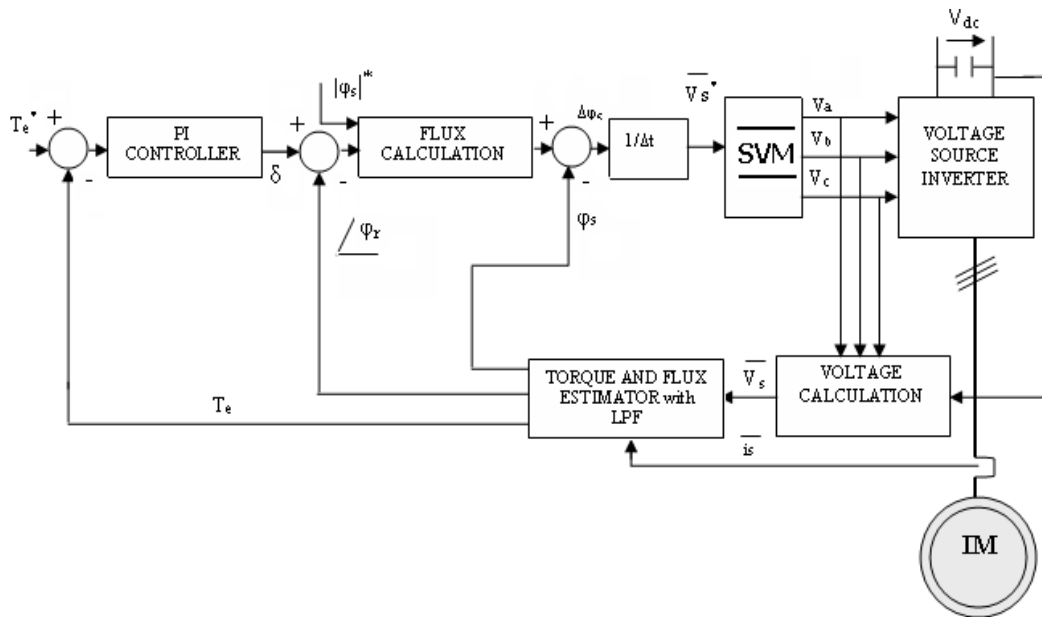

Figure 3. Block scheme of DTC-SVM with Low Pass Filter

**4. MATLAB/SIMULINK AND XILINX SYSTEM GENERATOR SIMULATION RESULTS**

The proposed DTC-SVM is simulated using Matlab/Simulink and Xilinx System Generator software and the simulation results are given the following figures. Figure 4 gives the simulation results (steady state) of proposed DTC-SVM at 500RPM, Figure 5 at 1000 RPM and Figure 6 1500 RPM respectively.

The SVPWM based DTC for induction motor is simulated using XSG and Matlab/Simulink and Xilinx System Generator simulation of various blocks of proposed DTC-SVM are given Figure7(a)-(c) [19].

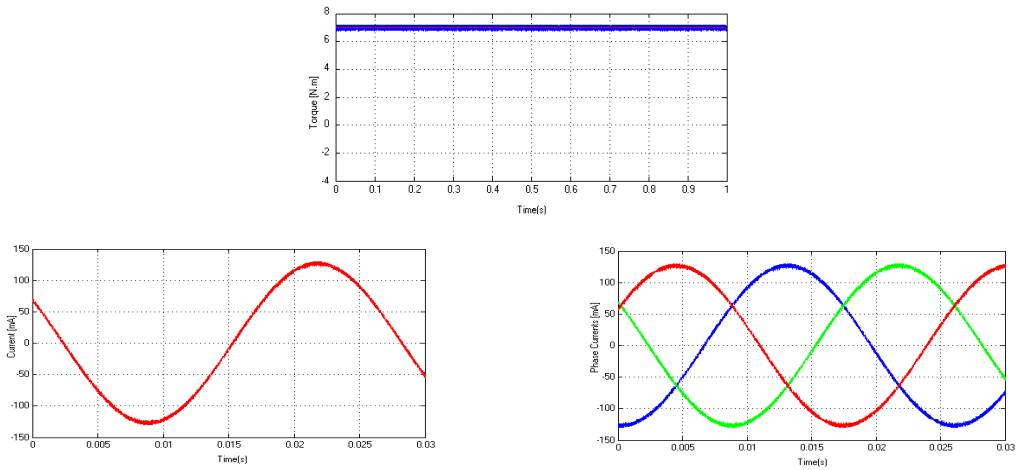

Figure 4. Torque response, phase current and three phase currents of DTC-SVM at 500 RPM

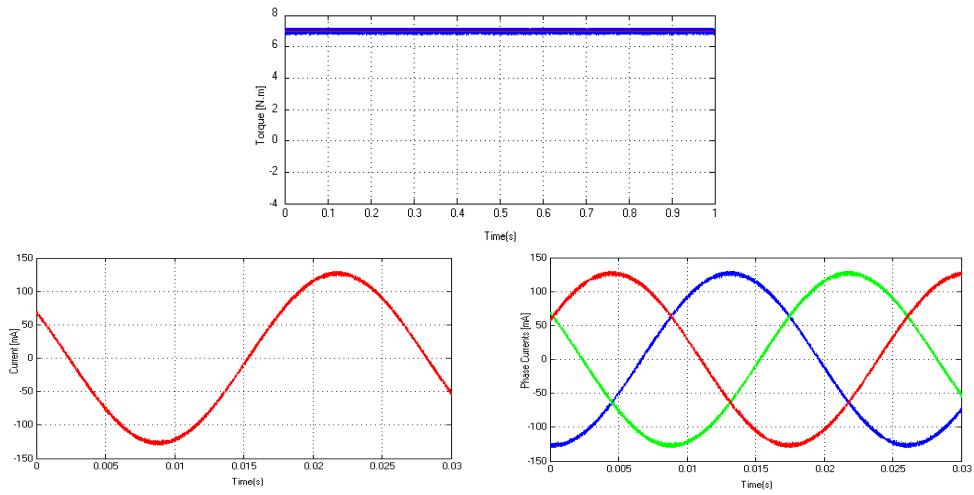

Figure 5. Torque response, phase current and three phase currents of DTC-SVM at 1000 RPM

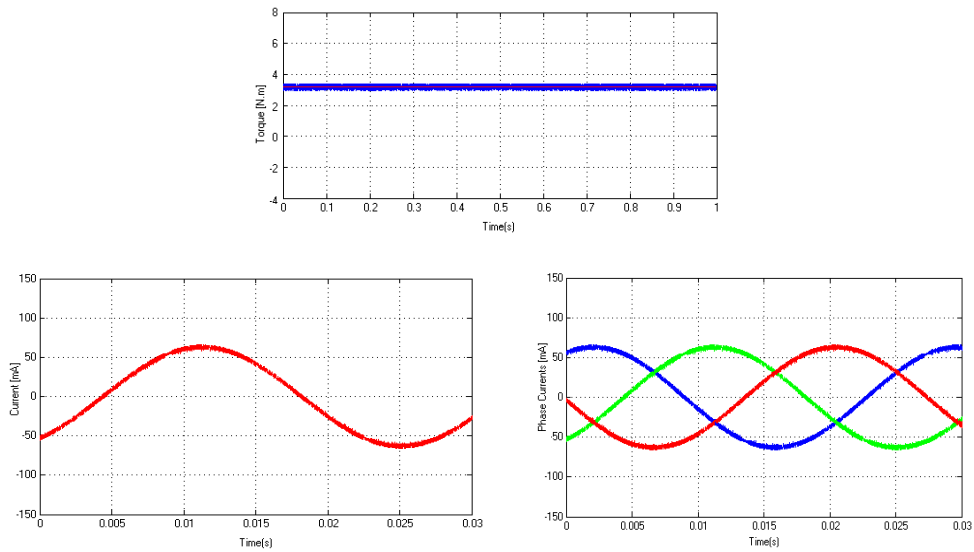
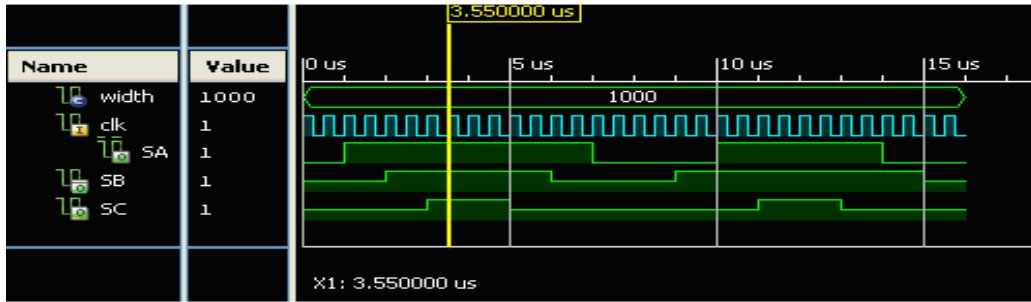
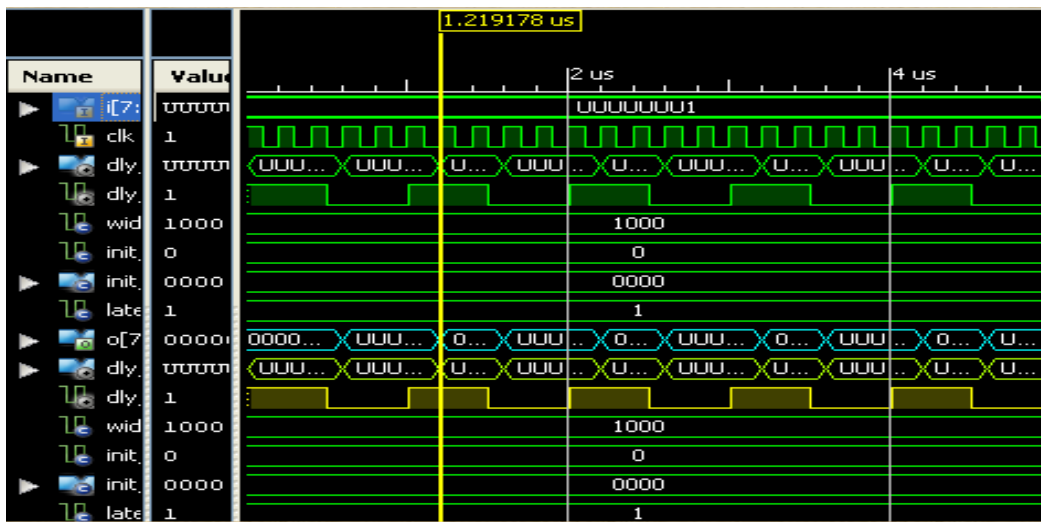

Figure 6. Torque response, phase current and three phase currents of DTC-SVM at 1500 RPM



(a)



(b)

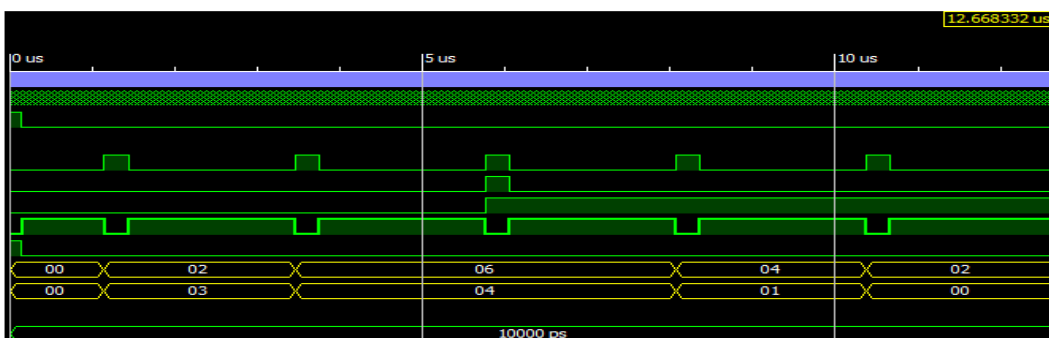

(c)

Figure 7 Simulation Results: (a) SVM switching pattern at sector I, (b) Torque and Flux Estimator, (c) PI Controller

**5. IMPLEMENTATION AND RESULTS**

We have tested the proposed DTC-SVM with low pass filter design using a three phase voltage source inverter connected to a 1kW load. In order to illustrate the efficiency of the proposed scheme, DTC-SVM was implemented utilizing Spartan SE FPGA as shown in Figure 8 and experimental results are shown in Figure 9(a)-(c).



Figure 8. Experimental setup

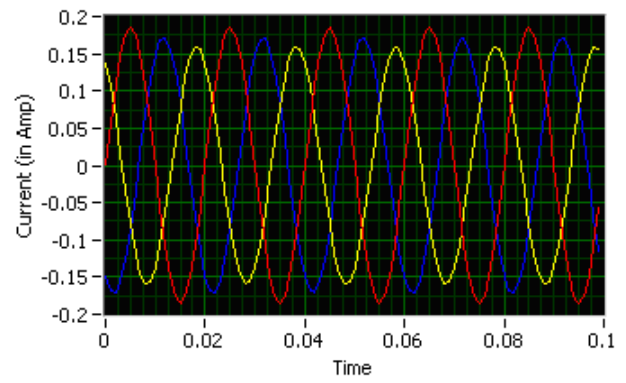
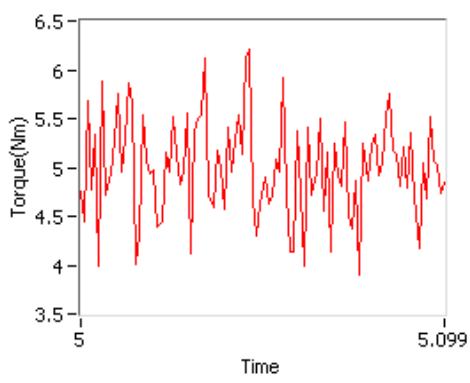

(a)

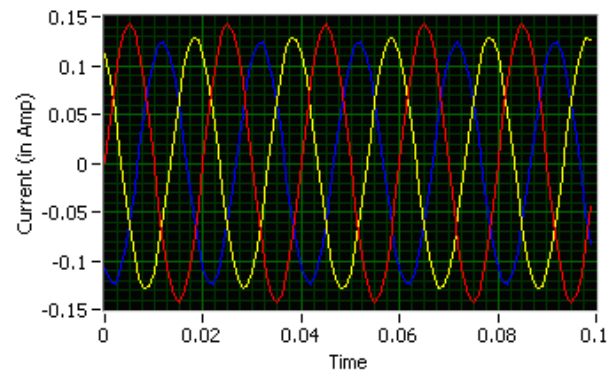
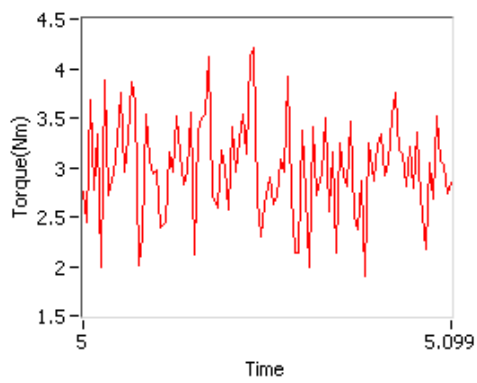

(b)

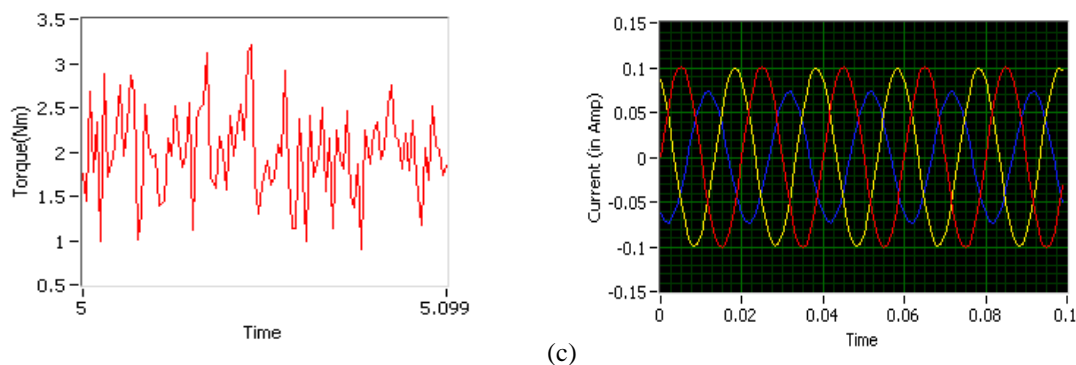

Figure 9 Experimental results, with torque response and three phase currents at: (a) 500 RPM; (b) 1000 RPM; (c) 1500 RPM

## 6. CONCLUSION

The conventional DTC is simple and gives quick response. But, it gives considerable ripple in torque, flux and current in the steady state. To reduce the ripple in steady state, in this paper, DTC-SVM is proposed. The proposed high performance scheme is designed using XSG and Matlab/Simulink blocksets and implemented on Xilinx Spartan FPGA. From the simulation and experimental results, it can be observed that, the novel proposed scheme able to produce good dynamic response.

## REFERENCES

- [1] I. Tahashi, T. Noguchi, "A New Quick Response and High Efficiency Control Strategy of an Induction Motor," *IEEE Transactions on Industrial Applications*, pp.820-827, 1986.
- [2] P. Tiitinen, M. Surendra, "The Next Generation Motor Control Method, Dtc Direct Torque Control," *Proceedings on Power Electronics*, pp. 37-43, 1996.
- [3] B.K. Bose, *Power Electronics and AC Drives*, Prentice-Hall, 1986.
- [4] D. Casadei, F. Profumo, G.Serra, A.Tani, "Effects of Flux and Torque Hysteresis Band Amplitude in Direct Torque Control of Induction Machines," *IEEE-IECON-94*, pp. 299-304, 1994.
- [5] D. Casadei, G. Serra, A.Tani, "Implementation of Direct Torque Control Algorithm for Induction Motors Based on Discrete Space Vector Modulation," *IEEE Transactions on Power Electronics*, pp.769-777, 2000.
- [6] T.G. Habetler, F.P.M. Pastorelli, I.M.Tolbert, "Direct Torque Control of Induction Machines using Space Vector Modulation," *IEEE Transactions on Industrial Applications*, pp. 1045-1053, 1992.
- [7] L. Tang, I. Zhong, M.F. Rahman, Y. Hu, "An Investigation of a Modified Direct Torque Control Strategy For Flux and Torque Ripple Reduction for Induction Machine Drive System with Fixed Switching Frequency," *IEEE-IAS*, pp. 837-844. 2002.
- [8] G. Griva, T. Habetler, "Performance Evolution of a Direct Torque Controlled Drive in the Continuous Square Wave Transition Region," *IEEE Transactions on Power Electronics*, vol.10, pp. 464-471, 1995.
- [9] Y.S. Lai, J.H.Chen, "A New Approach to Direct Torque Control of Induction Motor Drives for Constant Switching Frequency and Torque Ripple Reduction," *IEEE Transaction on Energy Conversion*, vol. 16, pp. 220-227, 2001.
- [10] L. Tang, M.F. Rahman, "A New Direct Torque Control Strategy for Flux and Torque Ripple Reduction for Induction Motor Drive by using Space Vector Modulation," *IEEE PESC 32<sup>nd</sup> International Conference*, pp.1440-1445, 2001.
- [11] C.S. Moreira, R.C.S. Freire, E.U.K. Melcher, et al, "FPGA –Based SVPWM Trigger Generator for a Three Phase Voltage Source Inverter," *Proceedings of 17<sup>th</sup> IEEE- Instrumentation and Measurement Technology Conference*, vol. 1, pp. 174-178, 2000.
- [12] T. Ying-Yu and Hau-Jean, FPGA realization of space-vector PWM control IC for three-phase PWM inverters, *IEEE Transactions on Power Electronics*, vol.12, 1997, pp. 953-963.
- [13] S. Berto, A. Paccagnella, Potentials and Pitfalls of FPGA applications in inverter drives-a case study, *Proceedings of IEEE-Industrial Technology*, pp. 500-505, 2003.
- [14] Amol A. Kalage, M. Vasant, "Modelling and simulation of FPGA Based Direct Torque Control of Induction Motor Drive," *International Journal of Recent Trends in Engineering*, vol.1, pp.72-74, 2009.
- [15] F. Aubepart, F. Poure, "VLSI Design Approach of Complex Motor Control, Case of Direct Torque Control of AC Machine," *Proceedings of the 7<sup>th</sup> IEEE International Conference on Electronics, Circuits and Systems*, pp.123-129, 2000.
- [16] Eric Monmasson, Marcian N. Cristea, "FPGA Design Methodology for Industrial Control Systems-A Review," *IEEE Transactions on Industrial Electronics*, vol. 54, pp.1824-1848, 2007.
- [17] Tole Sutikno, Azuani JIDIN, et al, "New Approach FPGA- Based Implementation of Discontinuous SVPWM," *Turkish Journal of Electrical Engineering and Computer Science*, vol.18, pp. 499-514, 2010.

- 
- [18] Jean-Gabriel Mailloux, et al, "FPGA Implementation of Induction Motor Vector Control using Xilinx System Generator," *Proceedings of 6<sup>th</sup> WSEAS International Conference on Circuit and Systems*, Egypt, pp. 252-257, 2007.
- [19] *Xilinx Application Notes*.