

Congestion Management in Hybrid Electricity Markets with FACTS Devices with Loadability Limits

Charan Sekhar, Ashwani Kumar

Department of Electrical Engineering, National Institute of Technology, Kurukshetra, India

Article Info

Article history:

Received Oct 15th, 2011

Revised Feb 5th, 2012

Accepted Feb 11th, 2012

Keyword:

Generator re-dispatch
Congestion management
Pool and Hybrid electricity market
Bid function
Loadability limit

ABSTRACT

Congestion management (CM) is one of the most important challenging tasks of the Independent System Operator (ISO) in the deregulated environment. In this paper, generators' rescheduling based CM approach to manage transmission line congestion considering loadability limit has been presented for hybrid based electricity market model. The main contribution of the paper is (i) to obtain secure transactions for hybrid market model, (ii) optimal rescheduling of generators with loadability limits taken into account with secure transactions, (iii) and impact of FACTS devices on transmission line congestion management. The ISO ensures secure bilateral transactions in a hybrid market model and CM is managed with minimum preferred schedule to obtain minimum congestion cost. The results have been obtained for IEEE 24 bus test system.

Copyright © 2012 Institute of Advanced Engineering and Science.
All rights reserved.

Corresponding Author:

Ashwani Kumar,
Department of Electrical Engineering,
National Institute of Technology,
Kurukshetra, Haryana, India.
Email: ashwaks@gmail.com

1. INTRODUCTION

With growing demand of electricity, the transmission network also needs expansion to transfer power. The transmission network with growing concerns of environment, right of way problems, and pressure for effective use of existing facilities in competitive environment can cause to violate its physical limits to carry more power which leads to the congestion in the transmission network. This congestion in the network may hamper market efficiency forcing the customers to back down power consumption due to rise in electricity prices. Thus, it is the utmost duty of the ISO to mitigate congestion utilizing different techniques may be cost free or cost based [1]. The basic transmission dispatch and congestion management model for congestion management is presented [2]. The basic concepts of transmission management, dispatch model, and role of the ISO and its model are presented in the paper.

The ISO can utilize corrective measures to manage congestion by utilizing transformer taps, rerouting of lines, and the outage of congested lines. However, the outage of lines can further aggravate the problem of congestion. These solutions may not help the ISO for CM and the ISO utilizes other market based solutions to manage the congestion more effectively.

Techniques based on prices, rescheduling of generators, zonal based methods, sensitivity based approaches, financial transmission rights, and FACTS applications to congestion management has been presented [3-26]. Fang and David [3-4] proposed a transmission dispatch methodology as an extension of spot pricing theory in a pool and bilateral as well as multilateral transaction model. Prioritization of electricity transactions and willingness-to-pay for minimum curtailment strategies has been investigated as a practical alternative to deal with the congestion. Authors in [5] proposed FACTS based curtailment based strategy based on [4] for congestion management. Harry Singh et al. [6] proposed approaches for congestion

management based on OPF, which utilizes DC load flow model to minimize the congestion cost for poolco model and bilateral model. The nodal pricing theory has been applied in the pool model whereas a method based on congestion cost allocation has been suggested for bilateral model. An optimal power flow based approach using nodal congestion price signals for computing the optimal power output of generators has been proposed in [7].

Authors in [8] proposed combined zonal and Fixed Transmission Right (FTR) scheme for congestion management has been proposed. The combined scheme has been utilized with locational marginal prices (LMPs) to define zonal boundaries appropriately. An OPF approach based on DC load flow as well as AC load flow has been formulated to minimize the net cost of re-dispatch to manage interzonal and intrazonal congestion [9]. A novel Lagrangian Relaxation based algorithm for area decomposition OPF, minimizing the congestion cost of re-dispatch in order to deal with the multi-zone congestion management, has been proposed in [10]. Both inter-zonal and intra-zonal congestion management problem has been formulated. Fast LP algorithm to manage congestion by rescheduling generation in Chinese electricity market is presented in [11]. An augmented Lagrangian Relaxation based algorithm has been proposed in [12]. Bompard et al. [13] developed a unified framework for mathematical representation of the market dispatch and re-dispatch problems, which is based on Congestion Management (CM) schemes and the associated pricing mechanisms. A unified framework has been used to develop meaningful matrices to compare the various CM approaches so as to assess their efficiency and effectiveness of the market signals provided to the market participants.

Kumar et al. proposed comprehensive survey of congestion management methods and categorized these methods based on their models for CM [14]. A congestion management approach based on real and reactive power congestion distribution factors based zones and generator's rescheduling was proposed in [15]. Kumar et al. proposed distribution factors based generators' rescheduling for CM [16]. FACTS deployment in the transmission network provides power flow control and helps to manage congestion in the network. Many authors utilized FACTS for congestion management [18-25]. Congestion management considering voltage stability constraints have been incorporated in [23]. FACTS based model for re-dispatching is presented in [24-25]. However, the congestion management methods have been applied for pool market model. Some of the authors have taken bilateral model into account, however, the optimal bilateral transactions have not been ensured during congestion management study.

In the present work, generation rescheduling based congestion management approach has been formulated along with the voltage stability constraint taken as loadability parameter. The approach has been also applied in a pool+bilateral mix market model where bilateral transactions are ensured optimal by the ISO before dispatching the generators. The main contribution of the paper is to propose (i) secure bilateral transactions model in pool+mix market for congestion management ensuring voltage stability limit. (ii) to propose the impact of FACTS devices viz., STATCOM, IPFC, and UPFC in the model for obtaining optimal re-dispatching of generators with minimum congestion cost. An optimal power flow problem using non-linear programming approach has been solved using CONOPT solver of GAMS with MATLAB interfacing [27-28]. The results have been obtained for IEEE 24 bus Reliability Test System [29].

2. POOL+BILATERAL MARKET MODEL

The conceptual model of bilateral dispatch is that sellers and buyers enter in to transactions where the quantities traded and the trade prices are at the discretion of these parties and not a matter of ISO. These transactions are then brought to the ISO with a request that transmission facilities for the relevant amount of power be provided. If there is no violation of static and dynamic security, the ISO simply dispatches all requested transactions and charges for the service. The bilateral concept can be generalized to the multi-node case where the seller, for example a generation company, may inject power at several nodes and the buyer also draw load at several nodes. Unlike pool dispatch, there will be a transaction power balance in that the aggregate injection equals the aggregate draw off for each transaction. A multilateral transaction differs from this multi-node bilateral model in that it envisages the activity of power broker. The concept of a broker is that of a firm which enters in to purchase & sales agreements with several buyers and sellers, a group. In this case the power balance constraints are that the broker's aggregate purchases from all generators at any time equal aggregate sales to all the broker's buyers. That is, all the transactions constituting a group needed to be balanced [24].

The most likely arrangements which will emerge in practical systems in the future is that a pool will exist simultaneously with bilateral and multilateral transactions. The significant difference between this model & pool model is that transmission sector is unbundled in to a "market" sector and a "security" sector. This model is shown in Figure 1.4. In the market sector, there are multiple separate energy markets,

containing a pool market taken care of by the Power Exchange and bilateral contracts established by the scheduling coordinators. The ISO is responsible for system operation and guarantees system security and in operational matters holds a superior position over the PX and SCs. The existence of a power pool is not mandatory in this model but will invariably be the case. Market participants may not only bid into the pool but also make bilateral contracts with each other. Therefore, this model provides more flexible options for transmission access. A California model is representative of this category. The Nordic model and the New Zealand Model also fall in to this category with some modifications. Other models such as the New York Power Pool (NYPP) and the Pennsylvania New Jersey Maryland (PJM) model fall somewhere in between these three categories.

A transaction matrix has been taken a collection of transactions between Gencos (G), Discos (D). The transaction matrix can be represented as:

$$[GD] = [DG^T] \quad (1)$$

Each element of GD, namely GD_{ij} , represents a bilateral contract between a supplier (P_{gi}) of row i with a consumer (P_{dj}) of column j . Furthermore, the sum of row i represents the total power produced by generator i and the sum of column j represents the total power consumed at load j .

$$GD \equiv \begin{bmatrix} GD_{1,1} & \dots & GD_{1,nd} \\ GD_{2,1} & \dots & GD_{2,nd} \\ \dots & \dots & \dots \\ GD_{ng,1} & \dots & GD_{ng,nd} \end{bmatrix} \quad (2)$$

where:

n_g = number of generators, and n_d = number of loads.

In general, the conventional load flow variables, generation (P_g) and load (P_d) vectors, are now expanded into two dimensional transaction matrix as:

$$\begin{bmatrix} P_d \\ P_g \end{bmatrix} = \begin{bmatrix} GD^T & 0 \\ 0 & GD \end{bmatrix} \begin{bmatrix} u_g \\ u_d \end{bmatrix} \quad (3)$$

Vector u_g and u_d are column vectors of ones with the dimensions of n_g and n_d respectively. There are some intrinsic properties associated with this transaction matrix GD. These are column rule, row rule, range rule, and flow rule. These properties have been explained in [30-31]. Each contract has to range from zero to a maximum allowable value, GD_{ij}^{\max} . This maximum value is bounded by the value of corresponding P_{gi}^{\max} or P_{dj} whichever is smaller. The range rule satisfies:

$$0 \leq GD_{ij} \leq GD_{ij}^{\max} \leq \min(P_{gi}^{\max}, P_{dj}) \quad (4)$$

It is also possible for some contracts to be firm so that GD_{ij}^0 is equal to GD_{ij}^{\max} [30]. According to flow rule the line flows of the network can be expressed as follows:

$$P_{line} = DF [P_g - P_d] \quad (5)$$

The matrix DF is the distribution factors matrix [31]. If the representations of the P_g and P_d are substituted by using the definition of GD as given in (29), the line flows can be expressed in an alternative as follows:

$$P_{line} = DF [GD - GD^T] \begin{bmatrix} 1 \\ \vdots \\ 1 \end{bmatrix} \quad (6)$$

The general problem formulation for determination of secure transaction matrix for hybrid market model can be represented as:

A. Objective function

Minimization of deviations from the proposed transactions GD_{ij}^0 :

$$\text{Min} \left\{ \sum_i \sum_j b_{ij} (GD_{ij} - GD_{ij}^0)^2 \right\} \quad (7)$$

B. Operating constraints

i) Equality constraints:

Power flow balance equations at each bus are:

$$P_i = P_{gi} - P_{di} = \sum_{j=1}^{N_b} V_i V_j [G_{ij} \cos(\delta_i - \delta_j) + B_{ij} \sin(\delta_i - \delta_j)] \quad \forall i = 1, 2, \dots, n_b \quad (8)$$

$$Q_i = Q_{gi} - Q_{di} = \sum_{j=1}^{N_b} V_i V_j [G_{ij} \sin(\delta_i - \delta_j) - B_{ij} \cos(\delta_i - \delta_j)] \quad \forall i = 1, 2, \dots, N_b \quad (9)$$

Power balance equations for demand and generation for hybrid market model using bilateral demand matrix GD are:

$$\mathbf{P}_{db} = \sum_i GD_{ij}, \quad \mathbf{P}_{gb} = \sum_j GD_{ij} \quad (10)$$

$$\mathbf{P}_g = \mathbf{P}_{gb} + \mathbf{P}_{gp}, \quad \mathbf{P}_d = \mathbf{P}_{db} + \mathbf{P}_{dp} \quad (11)$$

Power flow equations for hybrid model:

$$\mathbf{P}_{fb} = DF(\mathbf{P}_{gb} - \mathbf{P}_{db}) \quad (12)$$

$$\mathbf{P}_{fp} = DF(\mathbf{P}_{gp} - \mathbf{P}_{dp}) \quad (13)$$

$$\mathbf{P}_f = \mathbf{P}_{fb} + \mathbf{P}_{fp} \quad (14)$$

Equations (12) and (13) represents the real and reactive power flow injection at any bus i. Equations (13) to (14) represent the power flow balance equations for hybrid model.

ii) Inequality constraints:

Real and reactive power generation for generators:

$$\mathbf{P}_g^{\min} \leq \mathbf{P}_g \leq \mathbf{P}_g^{\max} \quad (15)$$

$$\mathbf{Q}_g^{\min} \leq \mathbf{Q}_g \leq \mathbf{Q}_g^{\max} \quad (16)$$

Transaction limit between seller bus-i and buyer bus j:

$$GD_{ij}^{\min} \leq GD_{ij} \leq GD_{ij}^{\max} \leq \min(P_{gi}^{\max}, P_{dj}^{\max}) \quad (17)$$

Limits on voltage magnitude and angle:

$$V_i^{\min} \leq V_i \leq V_i^{\max} \quad (18)$$

$$\delta_i^{\min} \leq \delta_i \leq \delta_i^{\max} \quad (19)$$

MVA power flow limit:

$$|\mathbf{S}_{ij}| \leq \mathbf{S}_{ij}^{\max} \quad (20)$$

Equations (15) to (20) represent the inequality constraints for real power generation, reactive power generation, and bilateral transactions, limits on the voltage magnitudes, voltage angles at each bus in the system, and MVA flow limit. The voltage limit, power angle limit has been considered between 1.05 p.u.

and 0.95 p.u., -30 degree to +30 degree, respectively. Secure bilateral transaction matrix utilizing equations (7) to (20) have been obtained using GAMS CONOPT solver with MATLAB interfacing.

3. STATIC MODEL OF FACTS DEVICES

In this section, it is explained the results of research and at the same time is given the comprehensive discussion. Results can be presented in figures, graphs, tables and others that make the reader understand easily [2], [5]. The discussion can be made in several sub-chapters.

3.1. Model of STATCOM

STATCOM consists of a converter, coupling transformer, and a DC capacitor. The main function of converter is to generate a fundamental output voltage waveform with the demanded magnitude and phase angle in synchronism with the AC system. Since, static compensator cannot generate or absorb real power (assuming no energy storage for STATCOM), power transmission of the system is affected indirectly by the voltage control. The reactive output power (capacitive or inductive) of the compensator is varied to control the voltage at given terminal of transmission network so as to maintain the desire power flow under possible system disturbances and contingencies [32].

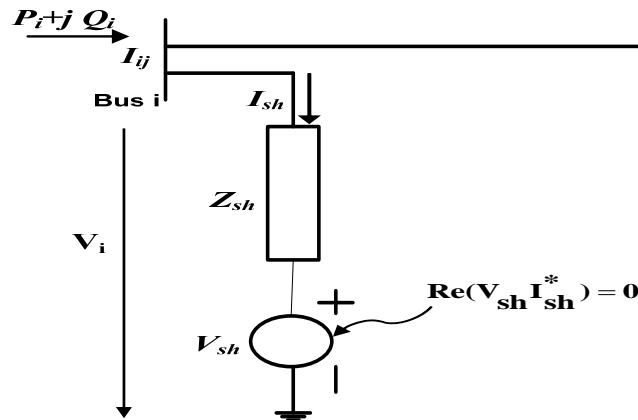

Fig.1. Model of STATCOM

For the power flow analysis, STATCOM will be represented by a synchronous voltage source with magnitude V_{sh} and angle δ_{sh} with its internal impedance Z_{se} applied in any bus i , shown in Fig 1. Then the real and reactive power injection at any bus i of the STATCOM are:

$$P_i^c = V_i^2 G_{sh} + V_i V_{sh} [G_{sh} \cos(\delta_i - \delta_{sh}) + B_{sh} \sin(\delta_i - \delta_{sh})] \quad (21)$$

$$Q_i^c = -V_i^2 B_{sh} + V_i V_{sh} [G_{sh} \sin(\delta_i - \delta_{sh}) - B_{sh} \cos(\delta_i - \delta_{sh})] \quad (22)$$

Operational constraint of the STATCOM (real power exchange via DC link) can be written as:

$$P_{exchange} = \text{Re}(V_{sh} I_{sh}^*) = 0 \text{ OR } V_i^2 G_{sh} + V_i V_{sh} [G_{sh} \cos(\delta_i - \delta_{sh}) - B_{sh} \sin(\delta_i - \delta_{sh})] = 0 \quad (23)$$

where

$$1/Z_{sh} = G_{sh} + jB_{sh}$$

3.2. Model of IPFC

IPFC can be modeled as multiple SSSC connected via common DC link. An IPFC with combining two or more series connected converters working together at their DC links. In addition to providing series reactive compensation, any converter can be controlled to real power to the common DC link from its own transmission line. For simplest form of the IPFC consists of two converters in series with two transmission lines. This can control the power flow of the two lines. The equivalent circuit of the IPFC consisting of two controllable series injected voltage sources is shown in Fig.3 Sum of real power exchange should be zero.

According to the equivalent circuit of IPFC shown in Fig.3, the injected Power equations can be written as [34]:

$$P_i = V_i^2 G_{ii} + \sum_h V_i V_h [G_{ih} \cos(\delta_{ih}) + B_{ih} \sin(\delta_{ih})] + \sum_h V_i V_{se,ih} [G_{ih} \cos(\delta_i - \delta_{se,ih}) + B_{ih} \sin(\delta_i - \delta_{se,ih})] \quad (24)$$

$$Q_i = -V_i^2 B_{ii} + \sum_h V_i V_h [G_{ih} \sin(\delta_{ih}) - B_{ih} \cos(\delta_{ih})] + \sum_h V_i V_{se,ih} [G_{ih} \sin(\delta_i - \delta_{se,ih}) - B_{ih} \cos(\delta_i - \delta_{se,ih})] \quad (25)$$

$$P_{hi} = V_h^2 G_{hh} + V_i V_h [G_{ih} \cos(\delta_{hi}) + B_{ih} \sin(\delta_{hi})] + V_h V_{se,ih} [G_{ih} \cos(\delta_h - \delta_{se,ih}) + B_{ih} \sin(\delta_h - \delta_{se,ih})] \quad (26)$$

$$Q_{hi} = -V_h^2 B_{hh} + V_i V_h [G_{ij} \cos(\delta_{ij}) - B_{ij} \sin(\delta_{ij})] + V_i V_{se,h} [G_{i,h} \cos(\delta_i - \delta_{se,h}) - B_{ih} \sin(\delta_i - \delta_{se,ih})] \quad (27)$$

Operating constraints of IPFC, real power exchange via common DC link should be zero.

$$P_{exchange} = \text{Re}(\sum_h V_{se,ih} I_{hi}^*) = 0 \quad (28)$$

$$\sum_h [V_i V_{se} [G_{ih} \cos(\delta_i - \delta_{se,ih}) - B_{ih} \sin(\delta_i - \delta_{se,ih})] + V_h V_{se} [G_{ih} \cos(\delta_h - \delta_{se,ih}) - B_{ih} \sin(\delta_h - \delta_{se,ih})]] = 0 \quad (29)$$

$$\text{Where, } G_{ii} = \sum_h G_{ih} ; B_{ii} = \sum_h B_{ih}$$

where $h=j, k, \dots$ etc.

Controllable injected voltage source bound constraints:

$$V_{se,ih \min} < V_{se,ih} < V_{se,ih \max} \quad \delta_{se,ih \min} < \delta_{se,ih} < \delta_{se,ih \max} \quad (30)$$

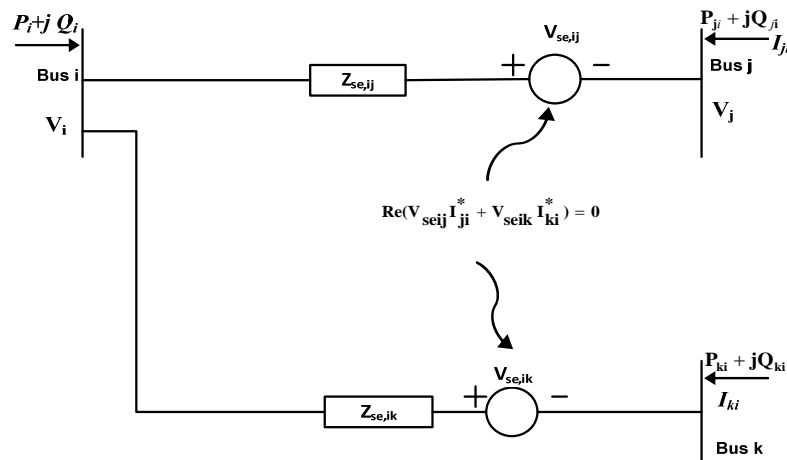

Fig.2. Model of IPFC

3.3 Model of UPFC

UPFC can be divided into two FACTS controllers, first one is series controller and second one shunt controller. Series controller is equivalent to the SSSC and shunt controller is STATCOM. When the STATCOM and the SSSC operate as standalone FACTS controllers, they exchange almost exclusively reactive power at their terminals. During the stand-alone operations, the SSSC injects a voltage in quadrature with the line current, thereby emulating an inductive and capacitive reactance at the point of compensation in series with the line, and the STATCOM injects a reactive current, thereby also emulating a reactance at the point of compensation in shunt with the line [32-33].

In the steady state operation, the main objective of an UPFC is to control voltage and power flow. The equivalent circuit of an UPFC is shown in Fig. 3.

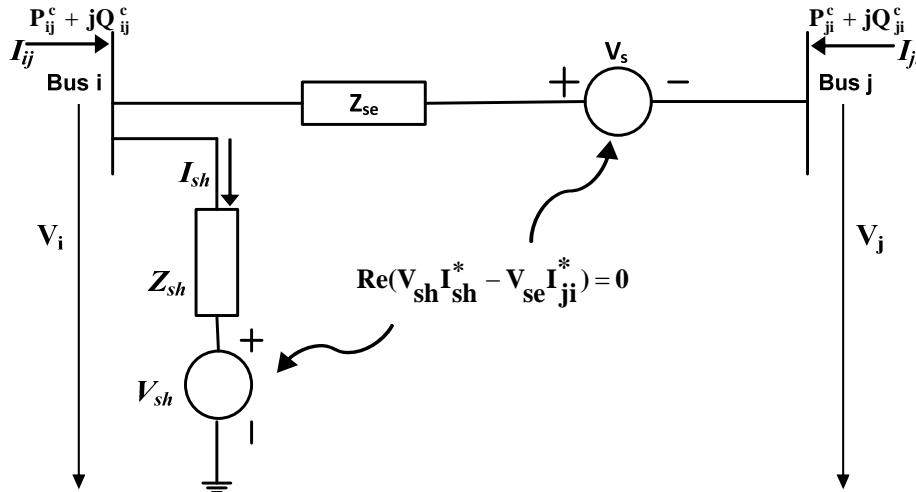

Fig. 3. Equivalent circuit of UPFC

Based on circuit shown in Fig. 3, the injected active and reactive power equations at bus i and bus j can be written as:

$$\begin{aligned}
 P_{ij}^c &= V_i^2 (G_{ii} + G_{sh}) + V_i V_j [G_{ij} \cos(\delta_{ij}) + B_{ij} \sin(\delta_{ij})] \\
 &+ V_i V_{se} [G_{ij} \cos(\delta_i - \delta_{se}) + B_{ij} \sin(\delta_i - \delta_{se})] \\
 &+ V_i V_{sh} [G_{sh} \cos(\delta_i - \delta_{sh}) + B_{sh} \sin(\delta_i - \delta_{sh})]
 \end{aligned} \tag{31}$$

$$\begin{aligned}
 Q_{ij}^c &= -V_i^2 (B_{ij} + B_{sh}) + V_i V_j [G_{ij} \sin(\delta_{ij}) - B_{ij} \cos(\delta_{ij})] \\
 &+ V_i V_{se} [G_{ij} \sin(\delta_i - \delta_{se}) - B_{ij} \cos(\delta_i - \delta_{se})] \\
 &+ V_i V_{sh} [G_{sh} \sin(\delta_i - \delta_{sh}) - B_{sh} \cos(\delta_i - \delta_{sh})]
 \end{aligned} \tag{32}$$

Operating constraints is real power exchange via DC link can be written as:

$$\begin{aligned}
 &V_i V_{se} [G_{ij} \cos(\delta_i - \delta_{se}) - B_{ij} \sin(\delta_i - \delta_{se})] \\
 &+ V_j V_{se} [G_{ij} \cos(\delta_j - \delta_{se}) - B_{ij} \sin(\delta_j - \delta_{se})] \\
 &+ V_i^2 G_{sh} + V_i V_{sh} [G_{sh} \cos(\delta_i - \delta_{sh}) - B_{sh} \sin(\delta_i - \delta_{sh})] = 0
 \end{aligned} \tag{33}$$

where $1/Z_{sh} = G_{sh} + jB_{sh}$; G_{ij} and B_{ij} are taken from Y_{bus} . The power flow equation obtained for FACTS can be added in an OPF model to incorporate the effect of FACTS devices for rescheduling of generators to remove congestion.

For congestion management, Gencos send bids to the ISO along with their maximum and minimum limits of generator rescheduling. The bid function can be constant bid or linear bid function. In this work, linear bid function has been considered. Based on the qualifying bids, the ISO send signals to the Gencos to regulate their output during congestion hours to mitigate congestion for which the generators are paid according to their qualified bids. For the generators to reschedule their generation up/down, their base case generation information is essential. This has been obtained solving optimal power flow problem with minimization of fuel cost. The congestion management model has been formulated as the non linear programming problem solved using GAMS CONOPT solver utilising MATLAB and GAMS interfacing.

4. CONGESTION MANAGEMENT MODEL WITH LOADABILITY LIMIT

In this section, it is explained the results of research and at the same time is given the comprehensive discussion. Results can be presented in figures, graphs, tab

$$\text{Min } F(x, u, p, \xi_{FACTS}, \lambda) \quad (34)$$

Subject to

$$h(x, u, p, \xi_{FACTS}, \lambda) = 0 \quad (35)$$

$$g(x, u, p, \xi_{FACTS}, \lambda) \leq 0 \quad (36)$$

F is an objective function, which is subjected to power flow equality constraints represented as h and all inequality constraints represented as g. Vector x represents state variables, u represents control variables, and p represents fixed parameters, ξ_{FACTS}, λ are the control parameters for FACVTS devices and loadability factor as voltage stability limit.

Objective function: Minimize congestion cost CC

$$CC = \sum_{d=1}^{nd} \Delta C(P_g^{up}) + \sum_{d=1}^{nd} \Delta C(P_g^{down}) \quad (37)$$

The components of the congestion cost CC are the sum of the linear bid functions of the demand submitted to the ISO for congestion management based on generation rescheduling. $bsmva$ is the base MVA and R_g^{up} and R_g^{down} are the up and down cost component in in \$/hr.

$$\Delta C(P_g^{up}) = k2 * \Delta P_g^{up} * bsmva + R_g^{up} \quad (38)$$

$$\Delta C(P_g^{down}) = k2 * \Delta P_g^{down} * bsmva + R_g^{down} \quad (39)$$

$k1$ and $k2$ are demand cost coefficients of a generation scheduling bid function submitted to the ISO in \$/MWh.

(a) Equality constraints

Let complex voltages at bus-i and bus-j are $V_i \angle \delta_i$ and $V_j \angle \delta_j$ respectively. The power injection equations at each bus can be written as:

$$P_i = \sum_{j=1}^{N_b} V_i V_j [G_{ij} \cos(\delta_i - \delta_j) + B_{ij} \sin(\delta_i - \delta_j)] \quad \forall i = 1, 2, \dots, N_b \quad (40)$$

$$Q_i = \sum_{j=1}^{N_b} V_i V_j [G_{ij} \sin(\delta_i - \delta_j) - B_{ij} \cos(\delta_i - \delta_j)] \quad \forall i = 1, 2, \dots, N_b \quad (41)$$

$$\sum_{g=1}^{Ng} \Delta P_g^{up} - \sum_{g=1}^{Ng} \Delta P_g^{down} = 0 \quad (42)$$

$$P_{gni} = P_g + \Delta P_g^{up} - \Delta P_g^{down} \quad (43)$$

$$P_i = P_{gni} - \rho * P_d \quad (44)$$

$$Q_i = Q_{gi} - Q_{di} \quad (45)$$

(b) Inequality constraints

(i) Up/down demand limits for demand management: The limits for up and down demand management are given by

$$\Delta P_{g \min}^{down} \leq \Delta P_g \leq \Delta P_{g \max}^{down} \quad (46)$$

$$\Delta P_{g \min}^{up} \leq \Delta P_g \leq \Delta P_{g \max}^{up} \quad (47)$$

$$P_{gn}^{\min} \leq P_{gn} \leq P_{gn}^{\max} \quad (48)$$

$$Q_g^{\min} \leq Q_g \leq Q_g^{\max} \quad (49)$$

$$V_i^{\min} \leq V_i \leq V_i^{\max} \quad (50)$$

$$\delta_i^{\min} \leq \delta_i \leq \delta_i^{\max} \quad (51)$$

(ii) Power flow limits

$$P_{ij}^2 + Q_{ij}^2 \leq (S_{ij}^{\max})^2 \quad (52)$$

Power balance equations for demand and generation for hybrid market model using bilateral demand matrix GD are:

$$\mathbf{P}_{db} = \sum_i GD_{ij}, \quad \mathbf{P}_{gb} = \sum_j GD_{ij} \quad (53)$$

$$\mathbf{P}_g = \mathbf{P}_{gb} + \mathbf{P}_{gp} \quad (54)$$

$$\mathbf{P}_d = \mathbf{P}_{db} + \mathbf{P}_{dp} \quad (55)$$

$$GD_{ij}^{\min} \leq GD_{ij} \leq GD_{ij}^{\max} \quad (56)$$

where

\mathbf{P}_g and \mathbf{P}_{gn} : are the base case generation and new schedule of generation obtained with demand side management.

\mathbf{P}_d : Base case power demand

ΔP_g^{up} : up scheduling of generator at bus- i for congestion management

ΔP_g^{down} : down rescheduling of generator at bus- i for congestion management

5. RESULTS AND ANALYSIS

In this section, results have been obtained for three different cases of line congestion with bid function submitted by the GENCOs to the ISO. The results have been obtained for IEEE 24 RTS. The cases for congestion in transmission lines have been considered assuming the power flow maximum rating in the corresponding lines below their base case power flows. For creating the congestion, the following lines have been taken:

Case 1: For single line (SL) congestion, power flow rating of 23rd line connected between buses 14 and 16 has been taken as 2.60 p.u. compared to its given rating of 5.00p.u.

Case 2: For two line (2L) congestion case, the rating of 18th line connected between buses 11 and 13 has been taken as 2.25 p.u. compared to its given rating of 5.00p.u. along with previous congested line.

Case 3: For three line (3L) congestion case, rating of 11th line connected between buses 7 and 8 has been taken as 1.50 p.u. compared to its given rating of 1.75p.u. along with previous two congested lines.

5.1. Generator Rescheduling Without FACTS

Secure transactions have been obtained solving GD matrix deviation minimization as described in section II. The proposed transactions and optimal transactions are given in Table I and II. The secure transactions have been incorporated calling GD matrix in GAMS from MATLAB environment in CC minimization problem as described in section III. The up and down generation obtained for SL, 2L, 3L congestion cases are given in Table III. In the table base case optimal power generation, \mathbf{P}_g and new \mathbf{P}_g after removing congestion for all congestion cases are also given. The generators which are participating for the congestion management with their up and down generation, \mathbf{P}_g , new \mathbf{P}_g are also given in Table III for all lines congestion cases. For two line and three line congestion cases, the \mathbf{P}_g , new \mathbf{P}_g , up and down generation rescheduling has been given in Table and shown in Figs.4 for 3L case.

Table I Proposed Bilateral Transaction Matrixes, GD_{ij}^0

Value of transaction between generator and load bus (p.u)				
G(1,1)=0.5	GD (1,2)=0.3	GD (1,3)=0.3	GD (1,15)=0.1	GD (1,18)=0.4
GD (2,10)=0.2	GD (2,13)=0.3	GD (2,15)=0.4	GD (2,18)=0.5	GD (2,19)=0.2
GD (7,9)=0.2	GD (7,10)=0.2	GD (7,13)=0.4	GD (7,15)=0.5	GD (13,18)=1.5

Table II Secure Bilateral Transaction Matrix

Value of transaction between generator and load bus (p.u.)					
GD(2,18)=.384	GD (13,18)=1.136	GD (21,8)=.158	GD (21,9)=.179	GD (21,13)=.2260	GD (21,15)=1.46
GD (21,18)=.145	GD (22,1)=.515	GD (22,2)=.485	GD (22,3)=.0197	GD (22,4)=.0197	GD (22,5)=.0169
GD (22,6)=.0169	GD (22,7)=.0197	GD (22,8)=.507	GD (22,9)=.119	GD (22,10)=.556	GD (22,13)=.253
GD (22,15)=.124	GD (22,16)=.474	GD (22,19)=.174	GD (23,1)=.0246	GD (23,3)=.0880	GD (23,4)=.350
GD (23,5)=.3381	GD (23,6)=.663	GD (23,7)=.605	GD (23,8)=.189	GD (23,9)=.576	GD (23,10)=.420
GD (23,13)=.846	GD (23,14)=.970	GD (23,16)=.0263	GD (23,19)=.731	GD (23,20)=.640	

TABLE III
GENERATORS UP AND DOWN GENERATION FOR CONGESTION MANAGEMENT

case	SL congestion case				2L congestion case				3L congestion case			
	P_G	P_{GTL}	ΔP_G^{up}	ΔP_G^{down}	P_G	P_{GTL}	ΔP_G^{up}	ΔP_G^{down}	P_G	P_{GTL}	ΔP_G^{up}	ΔP_G^{down}
1	1.3524	1.3524	0	0	1.3524	1.3524	0	0	1.3524	1.3524	0	0
2	0.15	0.3186	0.1686	0	0.15	0.9343	0.7843	0	0.15	0.95	0.8	0
7	3	2.99835	0	0.00165	3	2.99705	0	0.00295	3	2.73855	0	0.26145
13	5.91	5.91	0	0	5.91	5.34749	0	0.56251	5.91	5.16493	0	0.74507
15	2.15	2.15	0	0	2.15	2.15	0	0	2.15	2.95	0.8	0
16	1.55	1.55	0	0	1.55	1.33118	0	0.21882	1.55	0.75	0	0.8
18	4	4	0	0	4	4	0	0	4	3.2	0	0.8
21	1.26135	1.26135	0	0	1.261351	1.26135	0	0	1.26135	0.66787	0	0.59348
22	3	2.83308	0	0.16692	3	3	0	0	3	3.8	0.8	0
23	6.6	6.6	0	0	6.6	6.6	0	0	6.6	7.4	0.8	0

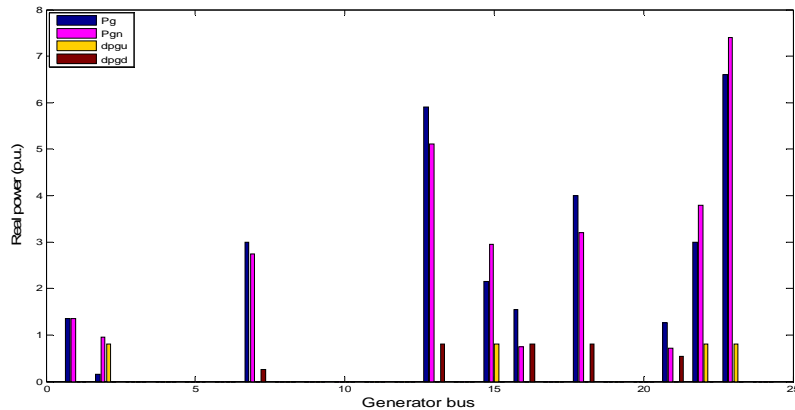

Fig. 4. Generator rescheduling for 3L congested case (without FACTS)

For single line congestion generator at bus 2 goes up generation and at buses 7 and 22 goes down generation. For 2L congestion, generator at bus 2 goes up generation and at bus 7, 13 and 16 goes down generation. For 3L congestion generator at buses 2, 15, 22 and 23 goes up generation and at bus 7, 13, 16, 18 and 21 goes down generation. The congestion cost, real and reactive power loss mentioned in Table VII.

5.2. Generator Rescheduling with STATCOM

The up and down generation obtained for single line, two lines, three line congestion cases are given in Table IV. In the table base case optimal power generation, P_g and new P_g after removing congestion for all congestion cases are also given. The generators which are participating for the congestion management with their up and down generation, P_g , new P_g are also shown in Fig.5 for 3L congestion. For two line and three line congestion cases, the P_g , new P_g , up and down generation rescheduling are also given in Table.

TABLE IV
GENERATORS UP AND DOWN GENERATION FOR CONGESTION MANAGEMENT (STATCOM)

Gen bus	SL congestion				2L congestion				3L congestion			
	P_g	P_{gn}	ΔP_g^{up}	ΔP_g^{down}	P_g	P_{gn}	ΔP_g^{up}	ΔP_g^{down}	P_g	P_{gn}	ΔP_g^{up}	ΔP_g^{down}
1	1.3524	1.3524	0	0	1.3524	1.3524	0	0	1.3524	1.3524	0	0
2	0.15	0.313	0.163	0	0.15	0.899	0.749	0	0.15	0.95	0.8	0
7	3	2.997	0	0.003	3	2.9941	0	0.0059	3	2.75	0	0.25
13	5.91	5.91	0	0	5.91	5.32	0	0.58	5.91	5.11	0	0.8
15	2.15	2.15	0	0	2.15	2.15	0	0	2.15	2.95	0.8	0
16	1.55	1.55	0	0	1.55	1.3871	0	0.1629	1.55	0.75	0	0.8
18	4	4	0	0	4	4	0	0	4	3.2	0	0.8
21	1.2613	1.2613	0	0	1.2614	1.26135	0	0	1.2614	1.1041	0	0.15725
22	3	2.8397	0	0.1603	3	3	0	0	3	3.6267	0.6267	0
23	6.6	6.6	0	0	6.6	6.6	0	0	6.6	7.18054	0.5805	0

Table V Generators up and down generation with IPFC

Gen	SL				2L				3L			
	P_g	P_{gn}	ΔP_g^{up}	ΔP_g^{down}	P_g	P_{gn}	ΔP_g^{up}	ΔP_g^{down}	P_g	P_{gn}	ΔP_g^{up}	ΔP_g^{down}
1	1.35246	1.35246	0	0	1.35246	1.35246	0	0	1.35246	1.35246	0	0
2	0.15	0.28058	0.1306	0	0.15	0.86188	0.7119	0	0.15	0.95	0.8	0
7	3	2.99999	0	0	3	2.99708	0	0.002917	3	2.74723	0	0.252766
13	5.91	5.91	0	0	5.91	5.39788	0	0.512118	5.91	5.11	0	0.8
15	2.15	2.15	0	0	2.15	2.15	0	0	2.15	2.59688	0.44688	0
16	1.55	1.49532	0	0.054677	1.55	1.35315	0	0.196849	1.55	0.82159	0	0.728406
18	4	4	0	0	4	4	0	0	4	4	0	0
21	1.261351	1.26135	0	0	1.26135	1.26135	0	0	1.26135	1.26135	0	0
22	3	2.92409	0	0.075905	3	3	0	0	3	3	0	0
23	6.6	6.6	0	0	6.6	6.6	0	0	6.6	7.13428	0.53428	0

Table VI Generators up and down generation with UPFC

	SL				2L				3L			
	P_g	P_{gn}	ΔP_g^{up}	ΔP_g^{down}	P_g	P_{gn}	ΔP_g^{up}	ΔP_g^{down}	P_g	P_{gn}	ΔP_g^{up}	ΔP_g^{down}
1	1.352	1.352	0	0	1.352	1.352	0	0	1.352	1.352	0	0
2	0.15	0.252	0.102	0	0.15	0.7832	0.6332	0	0.15	0.95	0.8	0
7	3	3	0	0	3	3.0050	0.0050	0	3	2.7572	0	0.2428
13	5.91	5.91	0	0	5.91	5.42378	0	0.48622	5.91	5.164313	0	0.7457
15	2.15	2.15	0	0	2.15	2.15	0	0	2.15	2.15	0	0
16	1.55	1.55	0	0	1.55	1.398	0	0.15197	1.55	1.056	0	0.4939
18	4	4	0	0	4	4	0	0	4	4	0	0
21	1.2614	1.2614	0	0	1.2614	1.2614	0	0	1.2614	1.2614	0	0
22	3	2.898	0	0.102	3	3	0	0	3	3	0	0
23	6.6	6.6	0	0	6.6	6.6	0	0	6.6	7.282	0.682	0

TABLE VII
CONGESTION COST

Congestion cost	Line congestion cases		
	SL congestion	2L congestion	3L congestion
Cost(\$/hr)	348.4286	594.7092	1561.034
Cost(\$/hr) with STATCOM	346.1992	580.5511	1403.903
Cost(\$/hr) with IPFC	333.2334	565.7533	993.4687
Cost(\$/hr) with UPFC	321.9994	536.2756	873.9588

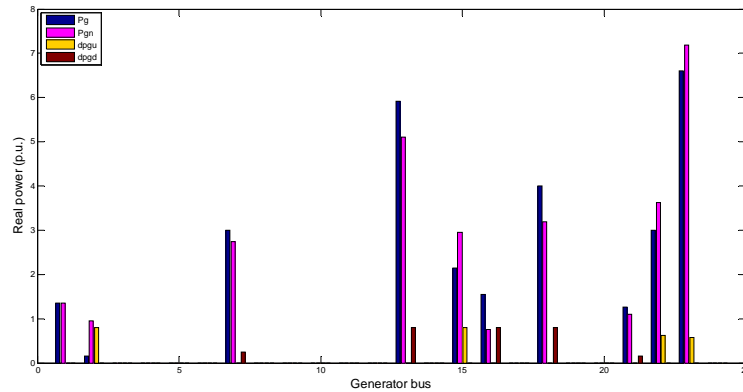

Fig. 5. Generator rescheduling with STATCOM at bus- 8 for 3L congested case

For single line congestion generator at bus 2 goes up generation and at buses 7 and 22 goes down generation. For 2L congestion, generator at buses 2 goes up generation and at buses 7, 13 and 16 goes down generation. For 3L congestion generator at buses 2, 15, 22 and 23 goes up generation and at bus 7, 13, 16, 18 and 21 goes down generation. The congestion cost, real and reactive power loss mention in Table VII.

5.3. Generator Rescheduling with IPFC

The up and down generation, Pg and new Pg after removing the congestion for SL, 2L, and 3L obtained and mentioned in Table V. The up and down generation schedule is shown in Fig. 6 for 3L case.

For single line congestion generator at bus 2 goes up generation and at buses 7, 16 and 22 goes down generation. For 2L congestion, generator at bus 2 goes up generation and at bus 7, 13 and 16 goes down generation. For 3L congestion generator at buses 2, 15 and 23 goes up generation and at bus 7, 13 and 16 goes down generation. The congestion cost, real and reactive power loss mention in Table VII.

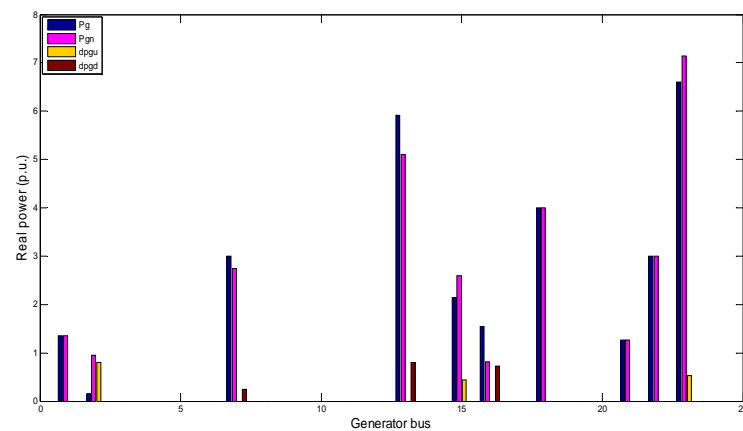

Fig. 6. Generators' rescheduling with IPFC on line-15 for 3L congestion

5.4. Generator Rescheduling with UPFC

The up and down generation, P_g and new P_g after removing the congestion for SL, 2L, and 3L are given in Table VI. The up and down rescheduling of Gencos are also plotted and is shown for 3L case in Fig. 7. For single line congestion generator at bus 2 goes up generation and at bus 22 goes down generation. For 2L congestion, generator at buses 2 and 7 goes up generation and at bus 13, 16, 18 and 21 goes down generation. For 3L congestion generator at buses 2 and 23 goes up generation and at bus 7, 13 and 16 goes down generation. The congestion cost is given in Table VII. The congestion cost is also shown in Fig. 8. It is observed that CC with FACTS reduces compared to the CC without FACTS for all line congestion cases. With UPFC, congestion cost is found lower compared to the other devices.

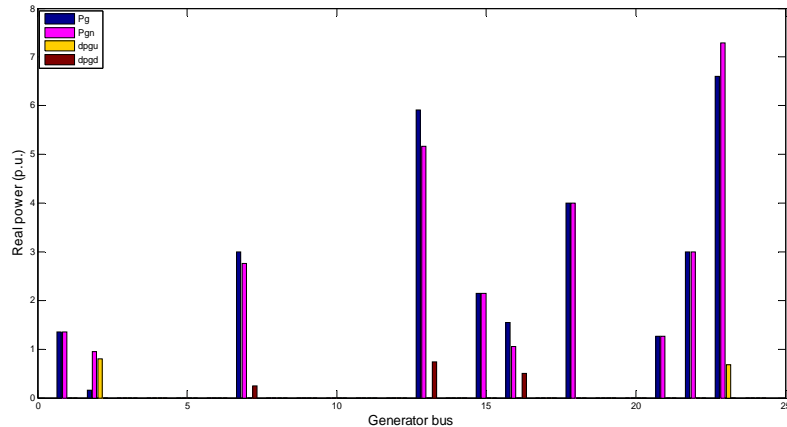

Fig. 7. Generator's rescheduling with UPFC on line-17 for 3L congestion

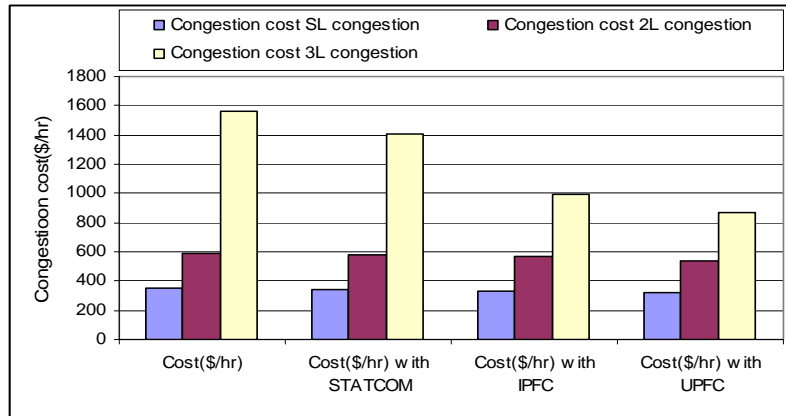

Fig. 8. Congestion cost (\$/hr)

6. CONCLUSION

In the paper, a congestion management approach considering loadability factor has been proposed for multi-line congestion cases. The secure transactions are obtained for hybrid market model. Generation rescheduling has been obtained to manage congestion for multi-line congestion cases with secure transactions and loadability limit. The impact of FACTS devices has also been incorporated to observe the impact on generator rescheduling. We observed that the congestion cost reduces with application of FACTS. The congestion cost depends by how much amount the line is congested. This is clearly observed in the 3L congestion case. The generators are set to lower preferred schedules with FACTS application. The overall congestion cost is found lower with UPFC compared to other FACTS devices.

REFERENCES

- [1] Mohammed Shahidepour and Muwaffaq Alomoush, *Restructured Electrical Power Systems, Operation, Trading, and Volatility*, Marcel Dekker, Inc. New York, 2001.
- [2] D. Shirmohammadi, B. Wollenberg, A. Vojdani, P. Sandrin, M. Pereira, F. Rahimi, T. Schneider, and B. Stott, "Transmission Dispatch and Congestion Management in the Emerging Energy Market Structures", *IEEE Trans. on Power Systems*, vol. 13, No. 4, Nov. 1998, pp. 1466-1476.
- [3] R.S. Fang and A.K. David, "Transmission Congestion Management in an Electricity Market", *IEEE Trans. on Power Systems*, vol. 14, No.2, Aug. 1999, pp. 877-883.
- [4] R.S. Fang and A.K. David, "Optimal dispatch under transmission contracts," *IEEE Trans. on Power Systems*, vol. 14, No.2, pp. 732-737, May 1999
- [5] S.C. Srivastava and Parveen Kumar, "Optimal power dispatch in deregulated market considering congestion management," in Proc. Int. Conf. on Electric Utility Deregulation and Restructuring and Power Technologies, DRPT, pp. 53-59, April 2000.
- [6] H. Singh, S. Hao, and A. Papalexopoulos, "Transmission Congestion Management in Competitive Markets", *IEEE Trans. on Power Systems*, vol. 13, No. 2, May 1998, pp. 672-680.
- [7] H. Glavitsch and F. Alavardo, "Management of Multiple Congested Conditions in Unbundled Operation of a Power System", *IEEE Trans. on Power Systems*, vol.13, No. 3, Aug. 1998, pp. 1013-1019.
- [8] M.I. Alomoush and S.M. Shahidehpour, "Fixed Transmission Rights for Zonal Congestion Management", *IEE Proc. on Generation, Transmission, and Distribution*, vol. 146, No. 5, Sept. 1999, pp. 471-476.
- [9] R.D. Christie, B.F. Wollenberg and I. Wangstien, "Transmission Management in the Deregulated Environment", *Proc. of the IEEE*, vol. 88, No. 2, Feb. 2000, pp. 170-195.
- [10] X. Wang and Y.H. Song, "Apply Lagrangian Relaxation to Multi-Zone Congestion Management", *Proc. of IEEE PES, Winter Meeting*, 2001, pp. 309-304.
- [11] J. Lie, Y. Deng, R. Zhang, and Y. Wu, "Congestion management for generator scheduling in a deregulated Chinese power system," *Proc. of IEEE PES, Winter Meeting*, pp. 1262-1265, 28 Jan.-1 Feb. 2001.
- [12] X. Wang, Y.H. Song, and Q. Lu, "Lagrangian Decomposition Approach to Active Power Congestion Management Across Interconnected Regions", *IEE Proc. on Generation, Transmission, and Distribution*, vol. 148, No. 5, Sept. 2001, pp. 497-503.
- [13] E. Bompard, P. Correia, G. Gross, and M. Amelin, "Congestion-Management Schemes: A comparative Analysis Under a Unified Framework", *IEEE Trans. on Power Systems*, vol. 18, No. 1, Feb. 2003, pp. 346-352.
- [14] Ashwani Kumar, S.C. Srivastava, and S.N. Singh, "Congestion management in competitive electricity markets-A bibliographical survey," *Electric Power System Research*, Vol. 76, No. 4, 2005, pp. 153-164.
- [15] Ashwani Kumar, S.C. Srivastava, and S.N. Singh, "A zonal congestion management approach using real and reactive power rescheduling," *IEEE Trans. on Power Systems*, Vol. 18, No. 1, Feb 2004, pp. 554-562.
- [16] A. Kumar, S.C. Srivastava, S.N. Singh, A zonal congestion management approach using AC transmission congestion distribution factors, *Electric Power Syst. Res.* Vol. 72, No. 11, 2004, pp. 85-93.
- [17] Wladyslaw Mielczarski and George Anders "Congestion management by commitment & dispatch in balancing market" *CIGRE/IEEE PES, 2005. International Symposium*, pp. 331 – 338, 7-7 Oct. 2005.
- [18] J. Brosda and E. Handschin, "Congestion management methods with special consideration of FACTS devices," in *Proc. IEEE Power Tech Conf., Porto, Portugal*, 10th-13th Sept. 2001.
- [19] X. Wang, Y.H. Song, Q. Lu, and Y.Z. Sun, "Series FACTS devices in financial transmission rights auction for congestion management," *IEEE Power Engineering Review*, pp. 41-44, Nov. 2001.
- [20] G.M. Huang and P. Yan, "TCSC and SVC as re-dispatch tools for congestion management and TTC improvement," in *Proc. IEEE PES, Winter Meeting*, vol. 1, pp. 660-665, 27-31 Jan. 2002.
- [21] S. Pichaisawat, Y. H. Song, X.L. Wang, and X. F. Bang, "Combined Active and Reactive Congestion Management with FACTS Devices," *Electric Power Components and Systems*, vol. 30, pp. 1195-1205, Dec. 2002.
- [22] Kwang-Ho Lee, "Optimal siting of TCSC for reducing congestion cost by using shadow prices," *Electric Power and Energy Systems*, vol. 24, pp. 647-653, Oct. 2002.
- [23] S. Pichaisawat, Y. H. Song, and G.A. Taylor, "Congestion management considering voltage security constraints," in *Proc. Int. Conf. on Power System Technologies, Power Con*, pp. 1819-1823, 13-17 Oct. 2002.
- [24] M. Mandala and C.P. Gupta "Congestion management by optimal placement of FACTS device" *Power Electronics, Drives and Energy Systems (PEDES) & 2010 Power India, 2010 Joint International Conference on* 20-23 Dec. 2010, pp. 1 – 7.

- [25] Kennady Mwanza, You Shi, "Congestion management: Re-dispatch and application of FACTS," Master of Science thesis in international master Degree programme, Electrical Power Engineering, Chalmers University of Technology, Goteborg, Sweden, 2006.
- [26] G. Yesuratnam and M. Pushpa "Congestion management for security oriented power system operation using generation rescheduling" in *Proc. IEEE 11th International Conference on Probabilistic Methods Applied to Power Systems PMAPS 2010*.
- [27] A User's Guide, GAMS Software, A. Brooke, D. Kendrick, A. Meeraus, R. Raman, R.E. Rasenthal, *GAMS Development corporation*, 1998.
- [28] "MATLAB and GAMS: Interfacing Optimization and Visualization Software", Michael C. Ferris, August 10, 1999.
- [29] IEEE Reliability Test System, "A report prepared by the Reliability Test System Task Force of the Applications of Probability Methods Subcommittee", *IEEE Trans. on Power Apparatus and Systems*, vol. PAS-98, pp. 2047-2054, Nov.- Dec. 1979.
- [30] J. W. M. Cheng, F. D. Galiana, and D. T. McGills, "Studies of bilateral contracts with respect to steady state security in a deregulated environment," *IEEE Trans. on Power systems*, vol. 13, no. 3, pp. 1020-1025, Aug. 1998.
- [31] Ashwani Kumar Sharma, "New Secure Bilateral Transaction Matrix Determination Using AC Distribution Factors and Impact of TCPAR and TCSC on Its Pattern", *Electric Power Components and Systems* vol. 35, pp. 21-943, Aug. 2007.
- [32] L. Gyugyi, and N.G. Hingorani, "Understanding FACTS: Concept and Technology of Flexible AC Transmission System," Piscataway, NJ: IEEE Press 2001.
- [33] Ge Shaoyun, Optimal Power System Operation and Control Incorporating FACTS Devices, Ph.D. Thesis, The Hong Kong University, Aug. 1998.
- [34] J Zhang, A. Yokoyama, "Optimal Power Flow Control for Congestion Management by Interline Power Flow Controller (IPFC)," *Power System Technology*, 2006. PowerCon 2006. International Conference on 22-26 Oct. 2006, pp. 1 – 6.

Bibliography of authors



Charan Sekhar is a Masters student IN Power Systems in the Department of Electrical Engineering in Power Systems. He completed his masters in Sept. 2011. He has interests in the power systems restructuring, congestion management and FACTS role for congestion management.



Ashwani Kumar graduated in Electrical Engineering in 1988 from GBPUA&Tech. Pant Nagar, Uttranchal, did his masters in the area of Power Systems in 1994 in honors from Punjab University, Chandigarh. He completed his Ph.D. from IIT Kanpur in 2003. Presently he is an Associate Prof. in the Department of Electrical Engineering at National Institute of Technology, Kurukshetra. He has interests in Power Systems deregulation and restructuring, Distributed Generation, Demand side management, FACTS applications to Power Systems, and Price forecasting. He is life member of professional bodies as ISTE, IEI (India) and member of IEEE/PES.