

Multi Objective Directed Bee Colony Optimization for Economic Load Dispatch With Enhanced Power Demand and Valve Point Loading

S.K.Gachhayat¹, Saroj Kumar Dash², Priyambada Ray³

¹Department of Electrical Engineering, KIST, BPUT, Bhubaneswar, India

^{2,3}Department of Electrical Engineering, GITA, BPUT, Bhubaneswar, India

Article Info

Article history:

Received Sep 2, 2016

Revised Mar 22, 2017

Accepted Jun 11, 2017

Keywords:

Economic load dispatch
Particle swarm optimization
Valve point loading

ABSTRACT

Earlier economic emission dispatch methods for optimizing emission level comprising carbon monoxide, nitrous oxide and sulphur dioxide in thermal generation, made use of soft computing techniques like fuzzy, neural network, evolutionary programming, differential evolution and particle swarm optimization etc..The above methods incurred comparatively more transmission loss. So looking into the nonlinear load behavior of unbalanced systems following differential load pattern prevalent in tropical countries like India, Pakistan and Bangladesh etc., the erratic variation of enhanced power demand is of immense importance which is included in this paper via multi objective directed bee colony optimization with enhanced power demand to optimize transmission losses to a desired level. In the current dissertation making use of multi objective directed bee colony optimization with enhanced power demand technique the emission level versus cost of generation has been displayed via figure-3 & figure-4 and this result has been compared with other dispatch methods using valve point loading (VPL) and multi objective directed bee colony optimization with & without transmission loss.

Copyright © 2017 Institute of Advanced Engineering and Science.
All rights reserved.

Corresponding Author:

Saroj Kumar Dash,
Departement of Electrical Engineering,
GITA Engineering college BPUT, Bhubaneswar, India,,
India 752054
Email: hodeegita@gmail.com

1. INTRODUCTION

Traditional dispatch makes a simplification presuming that power plant efficiency increases quadratically, piece-wise linearly or linearly with the output. However, in real life valves control the steam coming into the turbine through separate nozzle groups. Each nozzle group attains better efficiency when operated at rated output. So, when the output increases, valves are opened in sequence in order to achieve highest possible efficiency for given output. The end result is a rippled efficiency curve. This gives rise to a distorted heat rate input output curve, displaying the impact of VPL. At its favor the cost of generation is updated with a sinusoidal dependence. The hybridization of multi agent system and bee decision making process makes multi objective directed bee colony (MODBC) to generate a fast solution and a better pareto front for economic dispatch. In this paper one of the bees is chosen at random to replace the existing scout bee.

Following two or more dominant bees, a linear combination of objective function is used to decide one of the dominant bees. Making use of user defined weighted combination random search technique for enhanced power demand multi objective directed bee colony optimization with enhanced power demand (MODBCEPD) finds better solution in the specific search area. Earlier methods on evolutionary programming

techniques[1]based on stochastic optimization,were restricted to moderate case systems for which the impact of enhanced power demand associated with MODBC technique was applied for better cost strategy comparatively in larger systems.The basic theme of economic dispatch [7] is to ascertain the optimal combination of power outputs of the generating units in electric power system so as to optimize the total fuel cost for a certain load demand satisfying operational constraints. The economic load dispatch (ELD) [3] problem is analyzed basically through intelligent systems involving VPL[11] and MODBC technique.Since a variable 3 step cost function involves Lagrangian philosophywhich is nonlinear by nature,that involves sinusoidal termsdemonstrating the valve point effect[11] .The cost of generation versus emission characteristic [4] with and without transmission loss [12]incorporating valve point analysis has been compared with swarm optimization technique[2] involving MODBC[9].In this dissertation the impact of enhanced power demand involving load frequency control loop(LFC) and automatic voltage regulator loop(AVR) for optimizing oscillations in frequency deviation and improving steady state performance,has been attempted.The MODBCEPD technique using PSO [6] based PID controller pertaining to the Zeigler Nichols method of tuning has been adopted in this dissertation. Cost of generation versus emission level of a thermal power plant with and without transmission loss incorporating VPL,MODBC and MODBCEPD optimization techniques has been analyzed in this dissertation and displayed vide FIG-3 and FIG-4 respectively.

2. VALVE POINT LOADING

Thermal power plants are characterized by multiple steamvalves. In order to analyze the fuel cost function the valve point loading [11] effect is described as follows, Let N be the number of units. The generation cost objective function for the thermal power plant in the proposed method can be represented by the cost function:

$$F_i^1 = \sum_{i=1}^{Ng} a_i p g_i^2 + b_i p g_i + c_i + \lambda |e_i \sin(P g_i \min - P g_i)|^{Rs / h} \tag{1}$$

Where, a_i , b_i and c_i are generation cost coefficients for the i_{th} generating unit of the proposed method with valve point loading subjected to condition:

$$\sum p g_i = P_d + P_l \tag{2}$$

Where $i=1,2,3,\dots,n$,

$p g_i$ be the power supplied by the i^{th} unit and P_D be the load demand in MW.The transmission loss for a 'n'unit electric power system is expressed as:

$$P_l = \sum_{m=1}^n \sum_{n=1}^n p g_m p g_n B_{mn} \tag{3}$$

$$\sum B_{mn} = \frac{\cos(\sigma_m - \sigma_n) \tilde{M} p_m \times M p_n \times R_l}{|V_m| \times |V_n| \cos \phi_m \times \cos \phi_n} \tag{4}$$

Where $p g_m$ = Real power generated by mth power plant,

$p g_n$ = Real power generated by nth power plant; B_{mn} =Transmission loss in per mega watt; σ_m =Bus voltage angle of mth power plant; σ_n = Bus voltage angle of nth power plant; $M p_m$ =Current distribution factor of mth plant; $M p_n$ = Current distribution factor of nth plant; ϕ_m =Phase angle of mth plant; V_m =Voltage at the mth bus; V_n = Voltage at the th bus; R_l =Load resistance, and ϕ_n = phase angle of nth plant.

Including valve point loading and incorporating transmission loss[12],[13] using conventional method the cost of thermal generation is expressed as:

$$F_i^2(pg) = \sum a_i pg_i^2 + b_i pg_i + c_i + \lambda(p_d + p_l - \sum pg_i) \quad (5)$$

Subjected to condition $pg_i(\min) \leq pg_i \leq pg_i(\max)$

2.1. Cost Criteria for Economic Load Dispatch Problem

Using the Lagrangian multiplier method, fuel cost function incorporating transmission loss was expressed in equation (5), by differentiating the equation (5) we get:

$$\frac{dF(pg)}{dpg_i} = 0 \quad (6)$$

$$\frac{\partial F(pg)}{\partial \lambda} = p_l - \sum pg_i + p_d \quad (7)$$

$$\Rightarrow 2a_i pg_i + b_i + \lambda \times \left(\frac{\partial p_l}{\partial pg_i} - 1 \right) = 0 \quad (8)$$

Equation (8) satisfies the equality constraint $\sum pg_i = (p_d + p_l)$, Dividing equation (7) by $2a_i$

$$pg_i + \frac{b_i}{2a_i} + \lambda \left[\frac{\frac{\partial p_l}{\partial pg_i} - 1}{2a_i} \right] = 0 \quad (9)$$

$$\Rightarrow \sum pg_i + \frac{\sum b_i}{2a_i} = \lambda \sum \frac{1}{2a_i} \left(1 - \frac{\partial p_l}{\partial pg_i} \right)$$

$$pg_i + \frac{b_i}{2a_i} = \frac{\lambda}{2a_i} \left(1 - \frac{\partial p_l}{\partial pg_i} \right) \quad (10)$$

The emission equation is expressed as,

$$E_i^1 = E_i^2 = \alpha_i pg_i^2 + \beta_i pg_i + \gamma_i + \eta_i \exp(k_i pg_i) \quad (11)$$

Where, α_i, β_i and γ_i, η_i and K_i are emission cost coefficients for the i_{th} generating unit of the proposed method.

3. MODBC

3.1. Description

In this paper, we make use of MODBC [9] for multi objective problems which is a hybrid version of multi agent system (MAS), that mimics its structure and modified Nelder–Mead [5] method to find an optimal solution based on the algorithm used by bees for finding a suitable place for establishing a new colony. The experimental results show the robustness and accuracy of MODBC over genetic algorithm [1] and PSO [2]. Due to its hybrid nature, this algorithm provides only deterministic solutions. Making use of these agent–agent [5] interactions and evolution mechanism of bee swarms in a lattice-like environment, the proposed method can find high-quality solutions reliably with the faster convergence characteristics in a reasonably good computation time.

The starting point and the number of agents are important issues while handling such algorithms. The choice of the number of agents and the starting point of search are also presented and discussed in this paper. The decision making process in the honey bees gives rise to an interesting swarm research area to work. Two different cases with different conditions have been considered in this optimization process. Aforesaid reported techniques were applied to the standard IEEE 30-bus [1] six-generator test case system.

3.2. MODBC Algorithm

- 1) Set the parameter, p . Set the length of steps, R_k ($k = 0, 1, 2, \dots, p$),
- 2) Where R_k stands for step size for the k th parameter.
- 3) (2) Set the range for each parameter as $[T_{ik}, T_{fk}]$ where $k = 0, 1, \dots, p$ where T_{ik}, T_{fk} represent the initial and final value of the parameter.
- 4) (3) Compute the number of steps in each step $n_k = \frac{T_{fk} - T_{ik}}{R_k}$.
- 5) (4) Compute the number of volumes $N_v = \prod_{k=1}^p n_k$.
- 6) (5) For individual volume, take the starting point of the explorations as the mid point of the volume, $\left[\frac{T_{i1} + T_{f1}}{2}, \frac{T_{i2} + T_{f2}}{2}, \dots, \frac{T_{ip} + T_{fp}}{2} \right]$.
- 7) (6) Search the volume according to modified Nelder–Mead method.
- 8) (7) Notice the value of optimal point obtained corresponding to each volume in form of $[Z_1, Z_2, \dots, Z_{N_v}]$.
- 9) (8) On completion of the search, the global optimized point making use of bee decision approach is as follows:
- 10) $F(Z_G) = \min[F(Z_1), F(Z_2), \dots, F(Z_{N_v})]$.

3.3. Analysis for MODBC Optimization Technique

The cost objective function presuming step wise linearized characteristics for MODBC neglecting transmission loss is expressed as:

$$F_i^3 = a_i p g_i^2 + b_i p g_i + c_i \quad (12)$$

One of the ingenious technique proposed for multi-objective directed bee colony optimization [9] is as follows:

$$E_i^3 = \alpha_i p g_i^2 + \beta_i p g_i + \gamma_i + \eta_i \exp(k_i p g_i) \quad (13)$$

Incorporating transmission loss the aforesaid cost and emission objective functions for multi-objective directed bee colony optimization is as follows:

$$F_i^4 = a_i p g_i^2 + b_i p g_i + c_i + \lambda(p_i - p - \sum p g_i) \quad (14)$$

$$E_i^4 = \alpha_i p g_i^2 + \beta_i p g_i + \gamma_i + \eta_i \exp(k_i p g_i) \quad (15)$$

3.4. Random Particle Search Methodology

The optimization of the given objective function is carried out via Nelder-Mead [5] method. In this methodology the function to be minimized is quite similar to food function of the agents i.e. the bees. To commence with we consider three vertices of a triangle as food points. The movement of the agent from initial food position towards the final one is carried out through Figure-1(a) where in a test point z_T is so considered that it is a reflection of worst food position denoted by z_3 as depicted in Figure 1(a). The vector z_T is expressed as:

$$z_T = 2 \times z_{12} - z_3 \quad (16)$$



a. Starting of otion search solution

b. Extrapolation optimization point towards global optimization point

Figure 1. Agents(bases) search movements with recent optimization algorithm

The movement of a bee by an additional distance d along the line marked in Figure 1(b) achieves a new position at point z_e . Since the function value at z_e is made less than that at z_T so it enables the agent for a better food approximation than z_T . The vector z_e shown in Figure 1(b) is expressed as:

$$z_e = 2 \times z_T - z_{12} \quad (17)$$

A further movement of d along the line of action of z_e yields a point z_f where in the agent has obtained a much better food point than z_e . The vector z_f shown in Figure-1(b) is expressed as

$$z_f = 2 z_e - z_T \quad (18)$$

It has been observed that the lattice center of the lattice is a good starting point for optimal solution which is achieved by a group of 50-60 agents in a pool.

4. MODBCEPD

The proposed method MODBCEPD for multi objective generation dispatch incorporating nonlinear behavior of power demand has been emphasized in this paper. The decision making, based on bee colony optimization [9] making use of the Nelder- Mead[5] method for associating a better food option for bees, has been used for optimizing the cost & emission function [4]. In this method a better food position for agents is extrapolated beyond point z_e [6,2] upto point z_f as shown in Figure 1(b) justifying the random power demand behavior. Section-4.1 reflects the formulation of cost objective and emission objective functions vide equation (19) to (22) with & without transmission loss [12] as described below.

4.1. Without loss

$$F_i^5 = a_i p g_i^2 + b_i p g_i + c_i \quad (19)$$

$$E_i^5 = \alpha_i p g_i^2 + \beta_i p g_i + \gamma_i + \eta_i \exp(k_i p g_i - p_d) \quad (20)$$

With loss

$$F_i^6 = a_i p g_i^2 + b_i p g_i + c_i + \lambda (p_d - p_l - \sum p g_i) \quad (21)$$

$$E_i^6 = (\alpha_i p g_i^2 + \beta_i p g_i + \gamma_i) + \eta_i \exp(k_i p g_i - p_d) \quad (22)$$

This paper used IEEE 30 bus test case system [1] comprising 6 generating units shown in Figure-2 for MODBCEPD analysis and comparison of results[8] with other soft computing techniques. The various

parameters [8] used for valve point loading, MODBCEPD technique, PID controller, ALFC loop & AVR loop [10] have been tabulated vide table-1 to table-6 respectively.

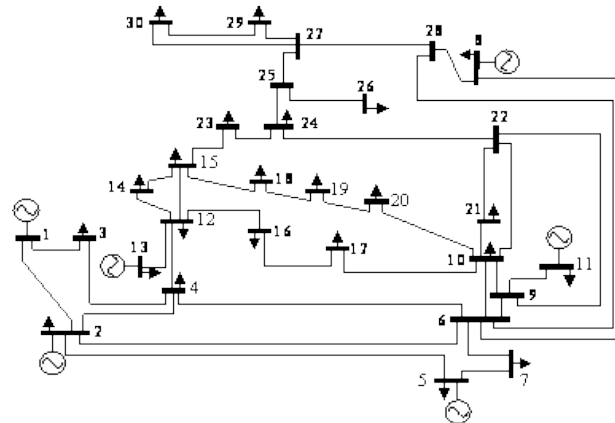

Figure 2. Single line diagram IEEE 30 bus test case system

4.2 Nelder Mead Method

At par with section-3.4 the waggle dance [5] of the bees for better food search options is attained at the point z_f converging to the optimal point [3,7] for the objective function. Section-4.2 realizes the utility of the Nelder Mead method at an extrapolated interval for meeting the nonlinear behavior of enhanced power demand up to point z_f as shown in Figure 1(b).

4.3. Simulation Results

Section-4.3 deals with simulation results for frequency deviation obtained out of ALFC and AVR loop [10] vide Figure 5 incorporating PID controller subjected to MODBCEPD optimization for optimizing cost of generation and emission level with and without transmission loss.

Section-2 deals with conventional optimization method using Lagrange multiplier with & without transmission loss incorporating valve point loading [11]. Finally the optimization result obtained for emission level versus cost of generation using VPL & MODBC technique is compared with MODBCEPD incorporating and neglecting transmission loss. It has been found from simulation result and conventional optimization method with valve point [14] loading that the MODBCEPD approach yields least cost of generation against variation of emission level [4] with and without transmission loss. This result has been displayed in Figure 3 and Figure 4. The simulation result illustrating the frequency deviation [10] is shown vide Figure 6 to Figure 8 with and without transmission loss.

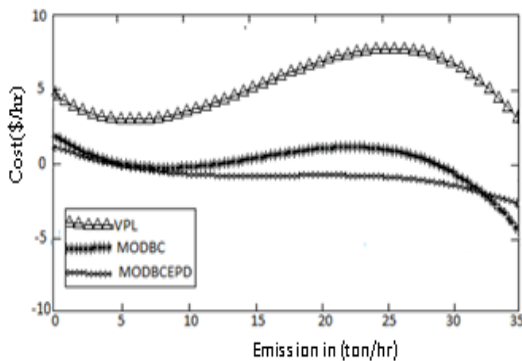

Figure 3. Various peroto-optimal fronts(with loss)

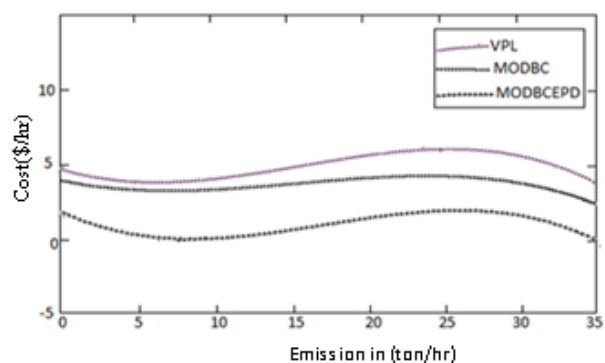

Figure 4. Various peroto-optimal fronts(without loss)

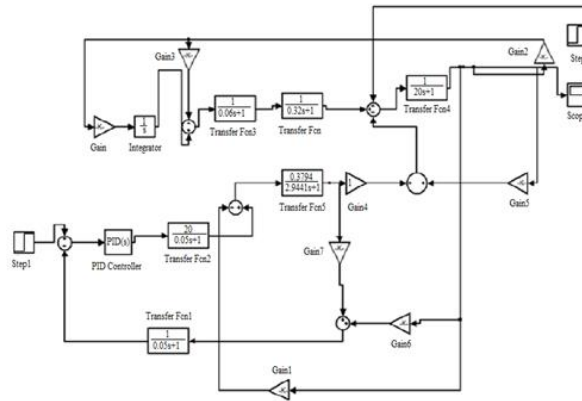

Figure 5. Simulink model for ALFC and AVR incorporating variable objective for PID controller exhibiting different tuning parameters

4.4. Performance Characteristics & Results

Various results pertaining to performance characteristics in Figure 3 and Figure 4 were tabulated vide table 1 to table 6.

Table 1. Fuel cost and emission cost function parameters for valve point loading (vpl)

ai	bi	ci	ei	pgi in pu	pd in pu	α_i	β_i	γ_i
0.059	1.18	0.59	0.46	0.55	0.55	0.0252	0.04	0.055
0.011	0.16	0.13	0.53	0.64	0.63	0.027	0.06	0.050
0.011	0.09	0.02	0.53	0.64	0.64	0.015	-0.05	0.045
0.015	0.15	0.09	0.54	0.65	0.65	0.017	-0.04	0.040
0.011	0.09	0.022	0.55	0.67	0.67	0.007	-0.05	0.045
0.016	0.24	0.16	1	1	1	0.009	-0.07	0.060

Table 2. Fuel cost and emission cost function parameters for modbcepd technique

ki	η_i	pl in pu	λ	Pg min in pu	Pg max in pu
2.0	1.007	0.09	3.01	0.04	0.4
2.4	1.15	0.31	4.05	0.04	0.5
2.2	0.99	0.58	6.0	0.04	0.9
3.0	1.12	0.39	3.0	0.04	1.2
3.3	1.04	0.48	6.0	0.04	1.0
3.3	1.19	1	6.5	0.04	0.7

Table 3. PID controller parameters (without loss)

Optimization technique	PID controller parameters (without loss)		
	k_p	k_i	k_d
VPL	65.6	5.2	77.7
MODBC	75.78	8.5	70.7
MODBCEPD	85.8	12.2	60.7

Table 4. PID controller parameters (with loss)

Optimization technique	Pid controller parameters (with loss)		
	T_H in sec	T_T in sec	T_P in sec
vpl	0.055	0.30	19
modbc	0.045	0.28	18
modbcepd	0.08	0.35	22

Table 5. ALFC parameters in per unit

K_1	K_P	T_P in sec	T_G in sec	T_T in sec	R in Hz/pu MW
1	102	20	0.06	0.32	1.7

Table 6. AVR parameters in per unit

K_1	K_2	K_3	K_4	K_5	K_F	K_A	K_E	T_E in sec	T_A in sec	T_F in sec
1.853	0.1632	0.3457	1.0304	0.0674	0.3794	1	20	0.05	0.05	2.9441

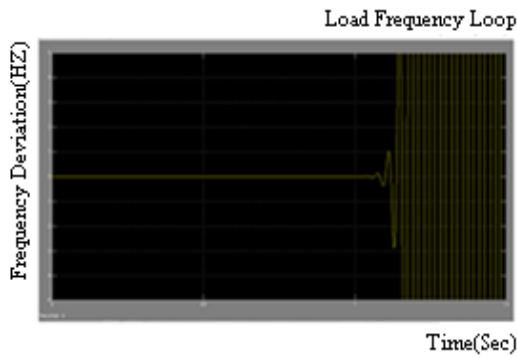

Figure 6(a). Frequency deviation for economic load dispatch involving valve point loading incorporating without transmission loss

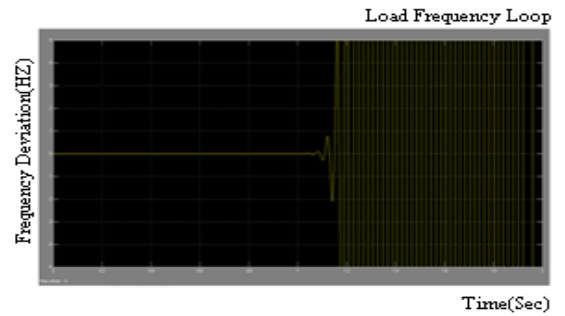

Figure 6(b) Frequency deviation for economic load dispatch involving valve point loading incorporating transmission loss

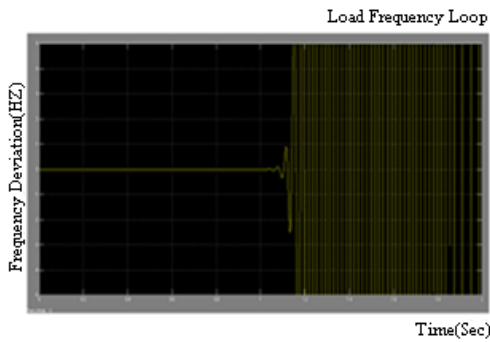

Figure 7(a) Frequency deviation for economic load dispatch involving MODBC without transmission loss

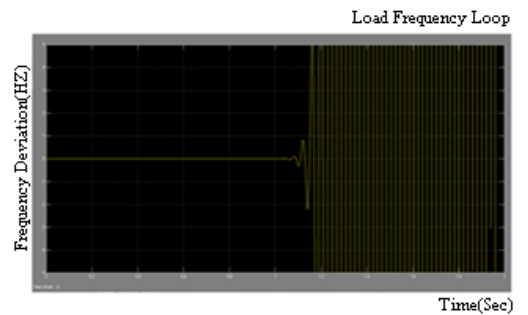

Figure 7(b) Frequency deviation for economic load dispatch involving MODBC incorporating transmission loss

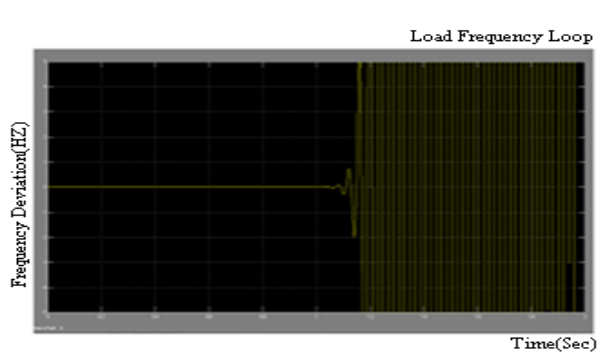

Figure 8(a) Frequency deviation for economic load dispatch involving MODBCEPD without transmission loss

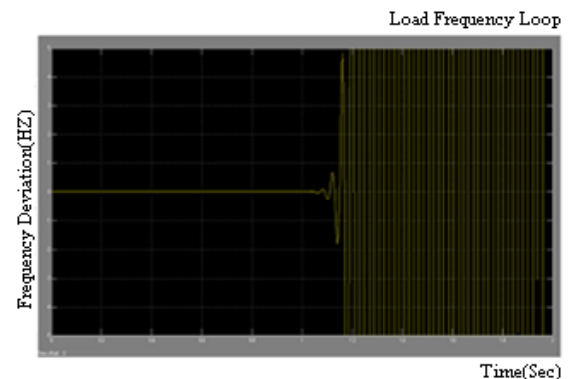

Figure 8(b) Frequency deviation for economic load dispatch involving MODBCEPD incorporating transmission loss

6. CONCLUSION

Electric power systems are highly complex interconnected networks. They transfer large amount of electric power over wide geographical areas. Scheduling of available generating resources to meet the load demand is a vital job of a power system operator. This generation-load balance should be achieved at minimum operating cost to receive the maximum benefits. The generation scheduling problem consists of determining the optimal operation strategy for the next scheduling period, subject to a variety of constraints. Economic operation is very important for any power system to achieve the profits on the capital investment. The importance of conservation of fossil fuels puts pressure on power companies to achieve maximum possible fuel efficiency by which the cost of kilo watt hour to the consumers can be minimized as the fuel prices are continuously rising.

Economic dispatch is an important optimization task in power system operations for allocating generation amongst the committed units such that all the constraints imposed are satisfied with minimum operating fuel cost. Improvements in the scheduling of unit outputs can lead to significant cost saving. Previous efforts at economic dispatch have applied various mathematical programming methods and optimization techniques. These methods represent the dispatch problem with quadratic fuel cost function and solve it by deterministic optimization techniques such as lambda iteration method, the gradient method and the dynamic programming method. These methods require continuously increasing fuel cost curves to find the global optimal solution. Gradient techniques perform well in their narrow class of problems, but it works inefficiently elsewhere. Later, Lagrangian methods have been increasingly used since they have the capability of including inequality constraints. These methods are based on the equal incremental cost criterion. It is desirable that the solution of power system problems should be globally optimal, but solutions searched for mathematical optimization is normally locally optimal. These facts make it difficult to deal effectively with many power system problems through strict mathematical formulation alone. Despite remarkable advancement in mathematical optimization techniques, conventional mathematical methods have yet to achieve fast and reliable real time applications in power systems.

Considerable efforts are required to avoid mathematical traps such as ill-conditioning and convergence difficulties. Since most classical methods used the point by point approach where one solution gets updated to a new solution in one iteration, parallel programming techniques cannot be exploited in solving the problem. This paper focuses on improvements in MODBC approach. Earlier studies using MODBC technique optimize the cost and emission function individually neglecting transmission losses [12]. Incorporating transmission losses and enhanced power demand in a random manner MODBCEPD technique yields best optimization results for cost of generation and emission level as well. Pareto-optimal curves [8] utilizing VPL, MODBC and MODBCEPD with and without transmission loss shown in FIG-3 & FIG-4 justify the efficacy of MODBCEPD technique over MODBC, VPL, PSO [6] and other soft computing techniques.

The simulated frequency deviation results following the variation of simulation time with and without transmission loss yield a better option to optimize real time and online optimization problems. Comparing the simulated result and MODBCEPD approach [8], it is found that the proposed scheme is more efficient and more effective than other soft computing techniques. The results obtained in this dissertation for

MODBCEPD can be utilized to realize complex industrial processes for obtaining optimum losses. This is however reasonably approximated for huge power plants encompassing a large number of units dealing with multi fuel options leading to convex optimization problems.

REFERENCES

- [1] M.A.Abido, "Multi objective evolutionary algorithms for electric power dispatch problem", *IEEE Transaction on Evolutionary Computation*, Vol.10, pp.315-329, 2006.
- [2] R. AlRashidi, M.E. El-Hawary, "Economic dispatch with environmental considerations using particles swarm optimization", *Power Engineering, Large Engineering Systems Conference*, pp.41-46, (2006).
- [3] R. Balamurugan and S. Subramanian, "A simplified recursive approach to combined economic emission dispatch", *Electric Power Component System*, vol.36, pp.17-27, 2008.
- [4] S.F. Brodsky, R.W. Hahn, "Assessing the influence of power pools on emission constrained economic dispatch", *IEEE Trans Power System, PWRS*-vol.1, pp.57-62, 1986.
- [5] K Pitchai Vijaya, KK Mahapatra, "Adaptive-fuzzy controller based shunt active filter for power line conditioners", *TELKOMNIKA Telecommunication, Computing, Electronics and Control*, vol. 9, no. 2, pp. 203-210, 2011.
- [6] Rajesh Kumar, Devendra Sharma, and Abhinav Sadu, "A hybrid multi agent based particle swarm optimization algorithm for economic power dispatch", *International Journal of Electric Power Energy System*, vol.33(1), pp.115-123, 2011.
- [7] S. Muralidharan, K. Srikrishna and S. Subramanian, "Emission constrained economic dispatch – a new recursive approach", *Electric Power Component System*, vol. 34, pp.343-353, 2006.
- [8] E. Zitzler and L. Thiele, "An evolutionary algorithm for multi-objective optimization, *The strength Pareto approach*", *TIK-Rep.*, 43, 1998.
- [9] Rajesh Kumar, Abhinav Sadu, Rudesh Kumar, and S.K. Panda, "A Novel multi-objective bee colony optimization algorithm for multi-objective emission constrained economic power dispatch", *Electrical Power and Energy Systems*, vol. 43 pp.1241-1250, 2012.
- [10] Siraparapu. Satyanarayana, R. K. Sharma, Mukta, and Mutual, "Effect between LFC And AVR Loops in Power Plant" *Electrical and Electronics Engineering*, Vol-3, No 1, pp.61-69, 2014.
- [11] Derong Liu, Ying Cai. (2005). Taguchi method for solving economic dispatch problem with non-smooth cost function. *IEEE transactions on power systems*, Vol.20, No. 4, 2006-2014.
- [12] N. Rama Raj and R. Raja Ram, "Analytical approach to optimize generation schedule of plant with multiple fuel options", *Journal of Institution of Engineers (India)*, Vol 68. pt EL Dec 1997.
- [13] Mallikarjuna Bestha, K. Harinath Reddy, O. Hemakeshavulu "Economic Load Dispatch Downside with Valve - Point Result Employing a Binary Bat Formula", *International Journal of Electrical and Computer Engineering (IJECE)*, vol-4, issue-1, pp. 101-107, 2014.
- [14] P.K. Hota *et al* 'Non-Convex Economic Dispatch with Prohibited Operating Zones through Gravitational Search Algorithm', *International Journal of Electrical and Computer Engineering (IJECE)*, Vol. 5, No. 6, pp. 1234-1244, 2015.