

Fuel Cell Impedance Model Parameters Optimization using a Genetic Algorithm

Mohamed Sélmene Ben Yahia, Hatem Allagui, Arafet Bouaicha, Abdelkader Mami

Department of Physics, Faculty of Sciences of Tunis, Tunis-El Manar University, Tunisia

Article Info

Article history:

Received Jul 8, 2016

Revised Nov 22, 2017

Accepted Oct 1, 2017

Keyword:

Genetic algorithm

Identification

Impedance model

Optimization

PEM fuel cell

ABSTRACT

The objective of this paper is the PEM fuel cell impedance model parameters identification. This work is a part of a larger work which is the diagnosis of the fuel cell which deals with the optimization and the parameters identification of the impedance complex model of the Nexa Ballard 1200 W PEM fuel cell. The method used for the identification is a simple genetic algorithm and the proposed impedance model is based on electric parameters, which will be found from a sweeping of well determined frequency bands. In fact, the frequency spectrum is divided into bands according to the behavior of the fuel cell. So, this work is considered a first in the field of impedance spectroscopy. So, this work is considered a first in the field of impedance spectroscopy. Indeed, the identification using genetic algorithm requires experimental measures of the fuel cell impedance to optimize and identify the impedance model parameters values. This method is characterized by a good precision compared to the numeric methods. The obtained results prove the effectiveness of this approach.

Copyright © 2017 Institute of Advanced Engineering and Science.
All rights reserved.

Corresponding Author:

Ben Yahia Mohamed Selméne,
Department of Physics,
Faculty of Sciences of Tunis,
University Tunis El Manar University,
El Manar, PB 2092, Belvedere, Tunisia.
Email: benyahia.selmene@gmail.com

1. INTRODUCTION

The global context is the diagnosis of the fuel cell. To do this it is necessary to model and identify the parameters of the impedance model. In fact, the modeling is a very important step in this work; it plays an important role in understanding the behavior of fuel cell systems, the works published by the investigators about the fuel cell modeling allowed us to have a global view of the different families of models such as mathematical, physical and electrochemical models. The choice of a model of an impedance of the fuel cell will mainly depend on the state of the fuel cell and physicochemical phenomenon in the PEMFC stack.

The modeling of the fuel cell in the literature is abundant; some authors model the fuel cell with impedance spectroscopy method [1]. The modeling by an equivalent electrical circuit has been used by several authors. An equivalent electric circuit in mass transport and electrochemical has been presented in the work of Gemmen et al [2]. The Modeling by the method of bond graph was also applied to the PEM stack in the work of Saisset et al [3]. The neural network modeling has been developed in the work of Samir Jemei et al [4]. The Empirical modeling of the fuel cell voltage has been treated by many researchers. For example Amphlett and al have [5] developed a model of the static voltage depending on the temperature and current.

The proposed model establishes the electrical model of the complex impedance of the fuel cell. Two reasons motivated this choice; the first is the experimental results found in the actual fuel cell. 1.2 kW Nexa and the presence of different physico-chemical phenomena during the chemical reaction in the fuel cell. This model is used to generate the parameters following this phenomenon. Indeed, in the impedance model, one

can follow the evolution of the model parameters based on the frequency. The second reason lies in the limited using of this model [6-8].

The second step is the identification of the parameters of the fuel cell impedance model. The majority of authors used numerical methods such as the method of least squares where the criterion to minimize J is fixed in advance, causing imprecision calculation of the model parameters.

We opted for a genetic algorithm that gives more precision since this algorithm optimization criterion J is minimized by this algorithm [9-11].

This paper is organized as follows. Section 2 describes the principal of the complex impedance model of the fuel cell. Section 3 reports the genetic algorithm identification method. Finally, the simulation results and discussion is explained in Section 4.

2. THE FUEL CELL IMPEDANCE MODELING

The modeling takes an important part in the development of the PEM fuel cell stacks, as it facilitates the understanding of the phenomena involved in their breasts. There exists a numerous cell models PEM, which generally each one have their specific characteristics and utility, the following phenomena studied [12].

Currently, the modeling of a fuel cell can be considered in two ways:

- a. Using the physical laws.
- b. Using the experimental results.

We will superpose the experimental results to the theoretical results to achieve a complete model.

2.1. The Simplest Impedance Model of the PEM Fuel Cell

For a fuel cell, several models can be developed according to the objective. The integration of a fuel cell in an electric environment requires the knowledge of its electric model. The model must be simple, accurate and sufficient to predict the electrical behavior under static conditions as under dynamic conditions. The simplest model can be a type of input-output model (equivalent circuit, for example) that would allow the description of the fuel cell behavior in its environment. The simplest representation of the fuel cell as an electric model consists of placing a DC voltage source in series with electrical impedance [13], as illustrated in by the Figure 1.

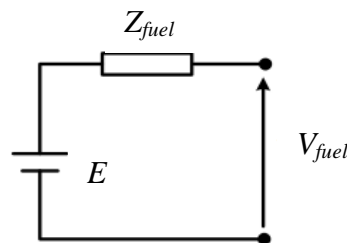

Figure 1. Representation of a Fuel Cell using a Voltage Source Associated with its Electrical Impedance [13]

The fuel cell impedance model is obtained by the frequency behavior of the complex impedance of the fuel cell as follows :

$$Z(f) = \text{Real}Z(f) + j.\text{Img}Z(f) \quad (1)$$

where $\text{Real}Z(f)$ is the real of the impedance of the fuel cell and $\text{Img}Z(f)$ is the imaginary part of the fuel cell impedance.

The experimental data generated by the electrochemical impedance spectroscopy method are mainly analyzed using an electric circuit model. The most of the circuit elements used in the model are the electrical elements such as resistance, capacitor, inductance and the electrochemical elements such as the Warburg impedances and constant phase element CPE.

2.2. The Electrochemical Impedance Spectroscopy Method

The electrochemical impedance spectroscopy (EIS) is a widely used method for the analysis of electrochemical systems. It allows one hand to follow the variation of the internal resistance of the fuel cell

and thus the humidifying state of the polymer membrane and also to observe the material transport phenomena and transfer charges to the electrodes. The measurement principle consists of the superposition of a signal of low amplitude to the output voltage of the fuel cell while it delivers the desired current.

The dynamic behavior of a fuel cell is conditioned by additional phenomena. For example, the concentration of the species is no longer considered to be constant. These phenomena therefore require a different approach for modeling a fuel cell. Dynamic analysis unveiled here takes into account the field of transport phenomena in the diffusion layer and transfers the load interfaces. However, material transport phenomena and the load in the active layer are neglected. The structure of the equivalent circuit varies depending on the analyzed frequency, for some phenomena are dominant over others. Now the dynamic is the main parameter for the use of a model.

The equivalent electric circuit of a PEM fuel cell can be illustrated by the Figure 2 [14]:

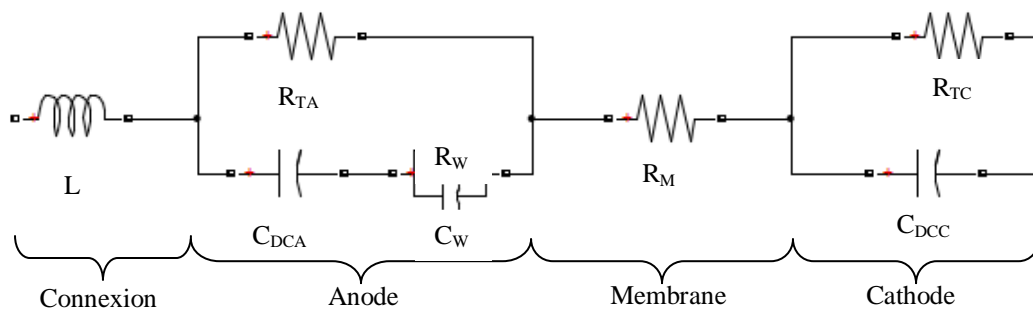

Figure 2. Circuit Equivalent of a Fuel Cell [14]

where:

- The inductive component L , models the impedance of the fuel cell as a bonding wire. It makes sense in high frequencies.
- The resistor R_M represents the membrane
- The resistors R_{TA} and R_{TC} are the transfer resistances of each electrode.
- The capacitors, C_{DCA} and C_{DCC} , model parasitic phenomenon capacitive electrodes. This phenomenon is known as the "double layer capacitance" which is related to the diffusion of species.
- The Warburg impedance Z_w essentially present in the anode. Represented by a combined resistance R_w to capacity C_w . It represents the diffusion phenomena

This impedance takes into account the load transfer conditions. The structure of this impedance may vary depending on the frequency range to be analyzed.

2.3. The Frequency Behaviour of the Impedance Model

The most common graphical representation of the experimental impedance is a Nyquist diagram (diagram complex plane), which is illustrative of a Bode diagram. However, a Bode plot can sometimes provide additional informations.

The variation of the frequency in the range [90mHz 12kHz] for example changes the Nyquist diagram form generated by the impedance model. It serves primarily to describe the different forms of the elements.

Some typical Nyquist plots for an electrochemical system are shown in Figure 3. The usual result is a semi-circle, with the high frequency portion giving the resistance to the solution (for a fuel cell, mainly the membrane resistance) and the width of the half circle giving charge transfer resistance).

Given all this, we developed sub-models according to the operating frequencies range. In fact, we will divide the impedance model by specters depending all of the frequency range behavior of the fuel cell in which that work. There are :

- The low frequencies interval [1 mHz, 100mHz]
- The average frequencies [100mHz, 1kHz]
- The high frequencies [1kHz, 10kHz]

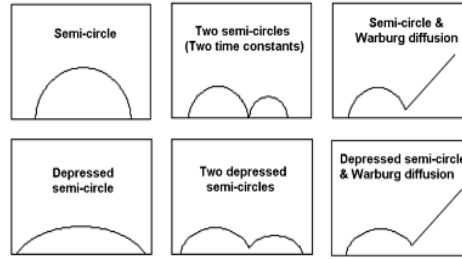

Figure 3. Typical Nyquist plots for electrochemical systems [15]

2.3.1. The Low Frequency Model

This model has the simplest representation of a fuel cell. This is the circuit where the faradic impedance in parallel with the double layer capacitor C_{DCC} is reduced in the charge transfer resistance R_{TC} . In this case, the diffusion phenomena are neglected [7]. The low frequency model is illustrated by the Figure 4.

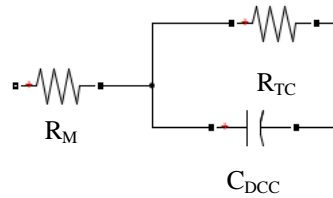

Figure 4. The impedance model for the low frequencies

The low frequency model equation is:

$$Z_{Bf}(\omega) = R_M + \frac{R_{TC}}{(1 + \omega^2 R_{TC}^2 C_{DCC}^2)} - j \frac{\omega R_{TC}^2 C_{DCC}^2}{(1 + \omega^2 R_{TC}^2 C_{DCC}^2)} \quad (2)$$

with $\omega = 2\pi f$

2.3.2. The Average Frequency model

The representation of a cell of the stack model of the average frequencies in the form of a circuit diagram is given in Figure 5. We consider here diffusion phenomena with finite diffusion layer. The convection-diffusion impedance is expressed by $R_W - C_W$ [14]. This is the pattern where the faradic impedance in parallel with the double-layer capacity is reduced to the charge transfer resistance.

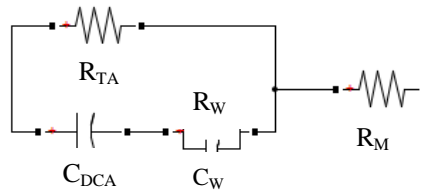

Figure 5. The impedance model for the average frequencies

The Average frequencies model equation is:

$$Z_{Af}(\omega) = R_M + \frac{R_{TA} + R_{TA} R_W^2 \omega^2 (C_W^2 + (C_{DCA}^2 (1 + R_{TA})))}{(1 + R_W^2 \omega^2 (C_W^2 + (C_{DCA}^2 (1 + R_{TA})))^2)} - j \frac{R_{TA} R_W \omega (C_{DCA} + C_W) - R_W R_{TA} \omega (C_W + C_{DCA} (1 + R_{TA}))}{(1 + R_W^2 \omega^2 (C_W^2 + (C_{DCA}^2 (1 + R_{TA})))^2)} \quad (3)$$

2.3.3. The High Frequency Model

The high frequency model has given permission to view the influence of the inductive element in the Nyquist plot. The assembly includes an inductor acts as an interconnection and a resistor R_M which represents the membrane and the various contact resistances. The high frequency model is illustrated by the Figure 6.

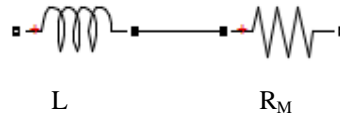

Figure 6. The Impedance Model for the High Frequencies

The equation of the high frequencies model takes the following form :

$$Z_{Hf}(\omega) = R_M + jL\omega \quad (4)$$

The parameters of this model will then be identified using a genetic algorithm.

3. THE GENETIC ALGORITHM IDENTIFICATION METHOD

3.1. The Method Description

This method is based on the superposition of the measurement results with the results of calculation. The goal is to solve the problem of the parameters identifying where we seek an optimal solution in terms of parameters. All solutions represent a population. For the coding of these solutions I can choose the binary or actual coding (this depending on the problem). In the case of the proposed model, we used the actual coding for the parameters of resistive element, capacitive and inductive can take very small values.

In the case of the characteristic of the electrochemical impedance spectroscopy, the problem is to find the optimal values of $L, R_M, R_{TA}, C_{DCA}, R_{TC}, C_{DCC}, R_W$ and C_W that minimize the mean square error (cost function) χ between the measurement values of the impedance of the actual fuel cell Z_{Mes} and those of the impedance of the proposed model Z_{Mod} .

To digitally process the Nyquist diagram that expressed the electrochemical impedance spectroscopy of the fuel cell, we made an adjustment procedure based on genetic algorithms. The error criterion used in the nonlinear fitting procedure is based on the sum of the squared differences between the theoretical and experimental current values. Therefore, the cost function to be minimized is given by [16-17]:

$$\chi = \sum_{i=1}^m (Z_{Mes} - Z_{Mod}(f_i; \theta))^2 \quad (5)$$

with $\theta = (L, R_M, R_{TA}, C_{DCA}, R_{TC}, C_{DCC}, R_W \text{ and } C_W)$

And Z_{Mes} is the impedance of the measured fuel cell corresponding to the frequencies f_i .

We start the accuracy of the adjustment procedure by the genetic algorithm in defining a chromosome as a choice of parameter values to be optimized. The chromosome is defined by the vector of parameters given by $[L, R_M, R_{TA}, C_{DCA}, R_{TC}, C_{DCC}, R_W, C_W]$. where the Chromosome = $[L, R_M, R_{TA}, C_{DCA}, R_{TC}, C_{DCC}, R_W, C_W]$.

To start the genetic algorithm, we define an initial population of chromosomes called IPOP defined by the equation given matrix (3) [18]:

$$IPOP = (hi - lo).random [Nipop, Npar] + lo \quad (6)$$

where:

Nipop: Number of chromosomes in the initial population

Npar: Number of parameters to be estimated

random [Nipop, Npar] : a function that returns a matrix Nipop*Npar Per from uniform random numbers between zero and one

hi : the largest value of each parameter

lo : the smallest value of each parameter.

The Selection: The selection determines and selects the members of the population that can reproduce. This selection allows to combine the individuals produced by the matrix of the initial population and determined to integrate individuals (values optimize) the first line of the initial matrix in the equation of the impedance model specified Z_{mod} , then compared with the measurements of the impedance of the fuel cell by the fitness function (called cost function) [18-19].

The Crossing: The crossing is an operator that provides mixing and recombination of parental genes to form new potential descendants, there is an exchange of genetic material between two breeders (parents) randomly selected sires selected to form two new chromosomes (or children). The crossing is selected from all individuals given by the initial population matrix [18-19].

The Mutation: Sometimes the previously presented method does not work well. If care is not taken, the genetic algorithm converges too quickly in a region of the surface of the cost. If this sector is the global minimum of the region, it's good. However, some function such as the one we used in the example has many local minima. If we do nothing this rapid convergence trend, we could end up in a local minimum rather than global. To avoid this problem, we will force the program to explore other areas in the parameter space using transfer procedure [18-19].

3.2. The algorithm description

The parameters identification procedure using a Genetic Algorithms is used in many applications [20-22]. We used this method to identify and optimize the PEM fuel cell impedance parameters according to the following chart. It is illustrated by the Figure 7.

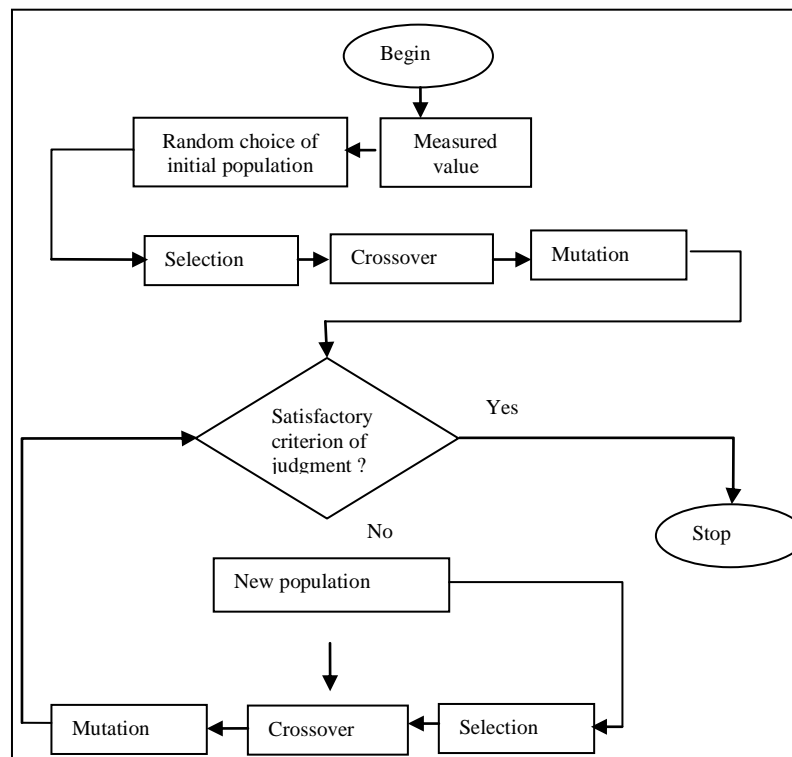

Figure 7. The Main Chart Calculation

The adjustment of the complex impedance model of the fuel cell with experimental measurements of the impedance of the Nexa fuel cell using the genetic algorithm and the variation of the minimum value of the mean square error X (cost function) of one generation to another. This value must be achieved the proposed requirement.

First, we are defined the data of genetic algorithm such as low limit values (LB) and high parameters (HB) to identify and stop criteria [22].

Second, the genetic algorithm selected randomly according to a uniform distribution individuals (parameters) forming the initial population in a matrix. This matrix defines the number of parameters using the number of columns and the number of population through the number line. Then, we use the equation of the impedance model of the fuel cell and the individuals of the initial population, the equation of the model gives the Nyquist diagram which expresses the complex equation of the impedance across a frequency range.

Finally, the fitness function calculates the error between the equation impedance model $Z_{mod}(f)$ and the measured of the fuel cell $Z_{mes}(f)$ in all points of the frequencies. If the equation of the fitness function reaches the error criterion proposed, the genetic algorithm is stopped and the results are displayed. If not, it applies the different genetic operators to generate the next population using the selected functions [22].

4. THE SIMULATION RESULTS AND DISCUSSIONS

It is evident that the method adopted is based on the superposition of the measurement results with the results of calculation. We will start with the presentation of certain practices which are then included in the model of practical results which are then introduced into the practice model that will then be brought into the simulation model.

4.1. The Measured Values

The Measuring the complex impedance by electrochemical impedance spectroscopy method requires hardware and software tools, for this reason we designed and produced an electronic load which can reach a current of 26A. The current range for testing by Nexa PEM fuel cell is 1A, 5A, 10A, 16A and 20A. The frequency range used by the function generator for measuring ranges from 0.01 Hz to 12 kHz, usually for a PEM fuel cell frequency spectrum is selected from 1 Hz to 10 kHz [14]. The Nyquist diagrams of the Nexa PEM fuel is illustrated by the Figure 8.

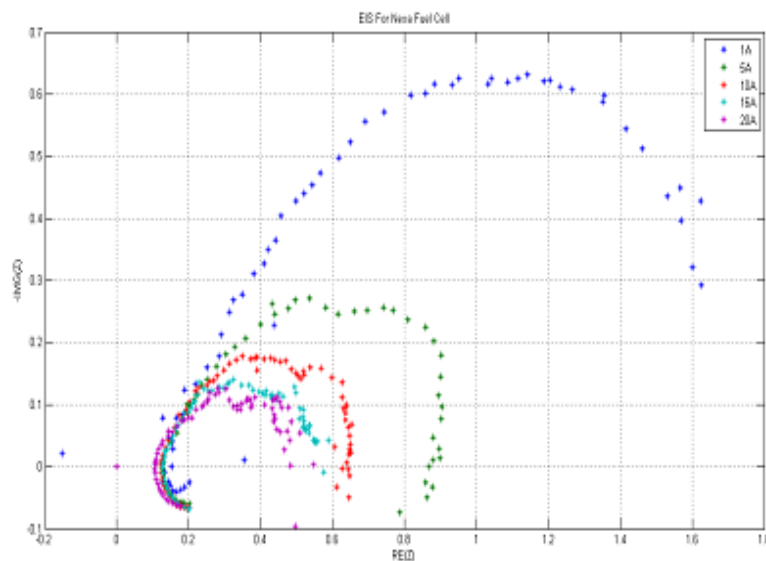

Figure 8. Nyquist Diagrams of the Nexa PEM Fuel Cell [14]

4.2. Simulations and Validation

In this part, we identified the parameters of the the fuel cell impedance of for a current value equal to 1A where the frequency varies between 90 mHz and 12 kHz. The individuals in our population $L, R_M, R_{TA}, C_{DCA}, R_{TC}, C_{DCC}, R_W$ and C_W are selected between the limit values. $[2, 1^{\circ}-4]$ for the resistive elements, $[1, 1^{\circ}-4]$ for the capacitive elements and $[1, 1^{\circ}-7]$ for the inductive elements. The fuel cell complex impedance optimum parameters $L, R_M, R_{TA}, C_{DCA}, R_{TC}, C_{DCC}, R_W, C_W$ provided by the genetic algorithm are summarized in the Table 1.

These results are obtained after 110 generations when the stop criterion is reached. It is noted that from one generation to the next fitness function of a decreases either side achieved increases to the condition of stop. Tracing the Nyquist curve using the values found by simulation of the genetic algorithm gave the curve shown in Figure 9 (green curve). This curve is almost similar to the experimental (Red Curve).

Table 1. The Optimal Parameters of the Complex Impedance of the Nexa PEM Fuel Cell

Parameters	Numerical Value
L(H)	0.000005
C _{DCA} (F)	0.03
R _{TA} (ohm)	1.4
R _w (ohm)	0.001
C _w (F)	0.03
R _M (Ohm)	0.1
C _{DCC} (F)	0.006
R _{TC} (ohm)	0.2

The adjustment of the Nyquist diagrams of the Nexa PEM fuel cell are given in Figure 9.

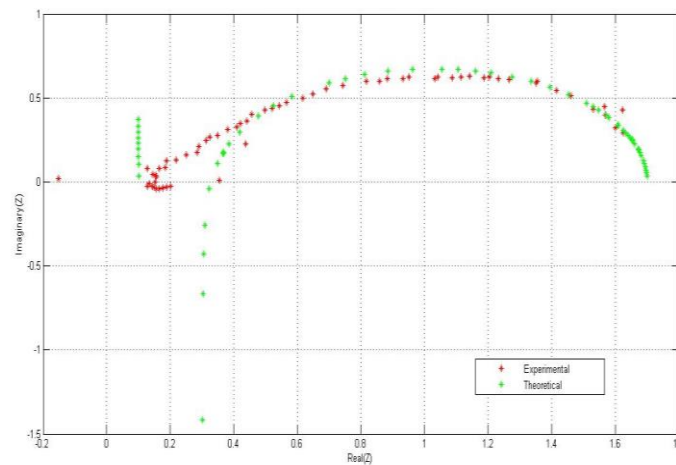

Figure 9. Adjustment of the Nyquist Diagrams of the Nexa PEM fuel cell for I=1A to the Impedance Theoretical Model

The difference appears at high frequencies (on the left of the curve). From Figure 9 we note that the Nyquist plot curve admits two lobes that express diffusion phenomena presented by Warburg impedance. The obtained numerical values demonstrate that the value of the inductor L is not confused in point measured by the real cell which considered as the value of L is changed according to the frequency. The program developed converges and give satisfactory results close to reality.

This validates the results found by our algorithm. Moreover, these values are almost identical to that obtained by Selmene et al using the least square method [23]. These results are also close to the mesurad values found by Reddad [24] et al. and Rouane [25] who worked on a fuel cell having the same characteristics as the Nexa fuel cell.

5. CONCLUSION

In this work, we have simulated the application of a genetic algorithm in order to characterize the impedance of a PEM fuel cell which is the Nexa of Ballard. It is used in particular for the determination of the electrical parameters such as the resistance of the membrane, the resistor transfers, the double layer capacity either to the anode or the cathode and the inductance of the connection.

The determination of these parameters from experimental data is formulated as an optimization problem. Solving this problem by programming techniques leads to less satisfactory results, depending on the initial conditions and leading to local minima. We have adopted genetic algorithms as a mean for determining these parameters.

We have selected the root mean square error to solve the fundamental problem of adjustment of the fuel cell impedance model experimental profile. Then we presented the various stages of the implementation of the genetic algorithm in continuous parameters. We have demonstrated the effectiveness of genetic algorithms through an identification program. The algorithm converged rapidly towards the global minimum

after 110 generations. The results have been highly satisfactory. The values found are identical to those found measured obtained by several authors.

Finally, we showed that this minimization technique using a genetic algorithm is very promising in determining the electrical parameters from experimental measures.

REFERENCES

- [1] L. Gerbaux, "Modeling a fuel cell type hydrogen / air and experimental validation," Thesis Ph.D., Institut National Polytechnique Grenoble, 1996.
- [2] P. Famouri and R. S. Gemmen, "Electrochemical Circuit Model of a PEM Fuel Cell," *IEEE Transactions*, vol. 3, pp. 1436-1439, 2003.
- [3] R. Saisset, "Contribution to the systemic study of electrochemical energy devices components. Bond Graph formalism applied to fuel cells, lithium-ion batteries, Solar Vehicle," Thesis of the National Polytechnic Institute of Toulouse, 2004.
- [4] S. Jemei, "Modeling of a PEM fuel cell neural networks," thesis of the University Belfort Montbeliard Technology and the University of France Count, 2004.
- [5] Amphlett J. C., *et al.*, "A model predicting transient responses of proton exchange membrane fuel cells," *Journal of Power Sources*, vol. 61, pp. 183-8, 1996.
- [6] E. H. Aglzim, "Characterization spectroscopy the complex impedance of impedance of a fuel cell in load Evaluation of the influence of moisture," Thesis, University Henri Poincaré- Nancy1, 2009.
- [7] I. Sadli, "Modeling impedance of a PEM fuel cell for power electronics in use," Thesis of the National Polytechnic Institute of Lorraine, 2006.
- [8] G. Fontes, "Modeling and Characterization of the PEM stack for studying interactions with static converters," Thesis of the National Polytechnic Institute of Toulouse, 2005.
- [9] I. S. Wibowo, *et al.*, "Design Simulation Program of Runway Capacity Using Genetic Algorithm at Soekarno-Hatta," *International Journal of Electrical and Computer Engineering (IJECE)*, vol/issue: 1(2), pp. 202-212, 2011.
- [10] J. R. Mohammed, "Comparative Performance Investigations of Stochastic and Genetic Algorithms Under Fast Dynamically Changing Environment in Smart Antennas," *International Journal of Electrical and Computer Engineering (IJECE)*, vol/issue: 2(1), pp. 98-105, 2012.
- [11] A. K. Yadav, *et al.*, "Design Optimization of High-Frequency Power Transformer by Genetic Algorithm and Simulated Annealing," *International Journal of Electrical and Computer Engineering (IJECE)*, vol/issue: 1(2), pp. 102-109, 2011.
- [12] I. V. Exposito, "Interfacing, monitoring and control of fuel cells for stationary applications and transport," Thesis of Electrotechnical Laboratory Grenoble in December, 2004.
- [13] M. Zandi, "Contribution to the management of hybrid electric power sources," Thesis of the University of the National Polytechnic Institute Lorrain. University, Nancy, 2010.
- [14] A. Bouaicha, *et al.*, "Design and Realization of an Electronic Load for a PEM Fuel Cell," *World Academy of Science, Engineering and Technology, International Science Index 85, International Journal of Electrical, Electronic Science and Engineering*, vol/issue: 8(1), pp. 202-207, 2014.
- [15] X. Y. Zi, *et al.*, "Electrochemical Impedance Spectroscopy in PEM Fuel Cells Fundamentals and Applications."
- [16] T. Easwarakhanthan, *et al.*, "Nonlinear minimization algorithm for determining the solar cell parameters with microcomputers," *Int. J. Solar Energy*, vol. 4, pp. 1-12, 1986.
- [17] Phang, *et al.*, "A review of curve fitting error criteria for solar cell I-V characteristics," *Solar Cells*, vol. 18, pp. 1-12, 1986.
- [18] M. Zagrouba, *et al.*, "Identification of PV solar cells and modules parameters using the genetic algorithms: Application to maximum power extraction."
- [19] M. H. Rachid, *et al.*, "Different evolutionary operators permutation: selections, crossovers and mutations," Research Report No. RR 2010-07 THEME 4 - COMPUTER LAB UNIVERSITY OF FRANCE-Comte-July 2010.
- [20] P. Alloto, *et al.*, "Stochastic algorithms in electromagnetic optimization," *IEEE Trans. Magn*, vol/issue: 34(5), pp. 3674- 3684, 1996.
- [21] H. Bezaze and A. H. Meniai "A predictive approach for thermodynamic modeling of solubility in supercritical fluids using genetic algorithm," *7th International Renewable Energy Congress (IREC)*, 2016.
- [22] A. Belkebir, *et al.*, "Identification et optimisation par algorithmes Génétiques des paramètres du modèle de l'hystérésis Magnétiques de Chua," *Revue des sciences et de la technologie-RST*, vol/issue: 1(1), pp. 27-34, 2009.
- [23] M. S. B. Yahia, *et al.*, "Parameters identification of the PEM Fuel cell impedance model," *2nd International Conference World Symposium on Mechatronics Engineering & Applied Physics, Sousse Juin*, 2015.
- [24] E. H. Agalzim, *et al.*, "An Electronic Measurement Instrumentation of the impedance of a Loaded Fuel Cell Battery gold.Sensors," 2007. (ISSN 1424-8220 © 2007 by MDPI www.mdpi.org/sensors).
- [25] A. Rouane, *et al.*, "Impedance Measurement of Fuel Cell is a Load," *9th International Conference electrical power quality and use, Barcelona october*, 2007.

BIOGRAPHIES OF AUTHORS

Mohamed Sélmene Ben Yahia was born in Tunis, Tunisia, in 1988. He received the Master's degree in Electronics, Electrical and automatic from the Faculty of Sciences of Tunis (FST) in 2014. Currently, he is pursuing the Ph.D. degree in Electronics with the Faculty of Sciences of Tunis, in the laboratory of Analysis, Design and Control Systems laboratory (LR-ACSENIT/FST- El Manar University) Tunis, Tunisia. His research interests include the identification and modeling of the systems fuel cell.



Hatem Allegui is an Assistant professor at the University of Sciences of Tunis. Now, is a searcher at the Analysis and Control Systems Laboratory. He obtained the diploma of engineer then the PHD in electrical engineering at 2003 from the National school of engineers of Tunis.



Arafet Bouaicha is a PhD student at the Faculty of Sciences of Tunis; he obtained his degree of engineer from National Engineering School of Tunis (ENIT) and a master's degree from the Faculty of Sciences of Tunis. His current research interest includes embedded electronics, power electronics, renewable energy and instrumentation for fuel cell.



Abdelkader Mami makes his research at the Faculty of Sciences of Tunis and member of laboratory Analysis, Design and Control Systems (LRACS-ENIT/FST), Tunis, Tunisia. His current interest includes automatic systems sampled, bond graph and renewable energy.