

American University in Cairo

AUC Knowledge Fountain

Theses and Dissertations

2-1-2018

Energy retrofit decision support model for existing educational buildings in Egypt

Rania Eltahan

Follow this and additional works at: <https://fount.aucegypt.edu/etds>

Recommended Citation

APA Citation

Eltahan, R. (2018). *Energy retrofit decision support model for existing educational buildings in Egypt* [Master's thesis, the American University in Cairo]. AUC Knowledge Fountain.

<https://fount.aucegypt.edu/etds/413>

MLA Citation

Eltahan, Rania. *Energy retrofit decision support model for existing educational buildings in Egypt*. 2018. American University in Cairo, Master's thesis. *AUC Knowledge Fountain*.

<https://fount.aucegypt.edu/etds/413>

This Thesis is brought to you for free and open access by AUC Knowledge Fountain. It has been accepted for inclusion in Theses and Dissertations by an authorized administrator of AUC Knowledge Fountain. For more information, please contact mark.muehlhaeusler@aucegypt.edu.

**The American University in Cairo
School of Sciences and Engineering
Construction Engineering Department**

**Energy Retrofit Decision Support Model for Existing Educational Buildings
in Egypt**

By

Rania Ahmed El Tahan

A thesis submitted in partial fulfillment of the requirements for the degree of

Master of Science in Construction Engineering

2017

Under the supervision of

Dr. Ossama Hosny

Professor,

Department of Construction Engineering

The American University in Cairo, Egypt

Dr. Khaled Tarabieh

Assistant Professor,

Department of Architecture

The American University in Cairo, Egypt

DEDICATION

For the two amazing Laila's in my life, my mother and my daughter.

For my loving husband, I am everything I am because you love me.

ACKNOWLEDGEMENTS

I wish to express my deepest gratitude and sincere appreciation to my thesis adviser Dr. Ossama Hosny, for his valuable advice, unconditional support, guidance and encouragement throughout all stages of this study. His effort and suggestions to improve the contents of this thesis were greatly appreciated. It has been an honor to work under his direction.

I would also like to extend my gratitude to my adviser Dr. Khaled Tarabieh, I truly appreciate his valuable assistance, patience, and guidance.

The knowledge I gained from my committee members has provided patience and richness to this research. I would also like to express appreciation to each of my committee members for the time they committed to my final defense.

My dear sister my backbone and main support thank you for always being there for me.

Finally, I would like to express my sincere thanks to Eng. Amr Yossif Labview Developer, Eng Ayman Galal and Eng Ahmed Taha for their technical support and extensive assistance. I would like also to express my sincere thanks as well to my colleagues at the AUC Facilities and Operations team for their technical support throughout each stage of my research.

Energy Retrofit Decision Support Model for Existing Educational Buildings in Egypt

By:

Rania Ahmed El Tahan

Thesis Advisor: Dr. Ossama Hosny

Thesis Co-Advisor: Dr. Khaled Tarabieh

ABSTRACT

This thesis presents a framework for developing a local decision support model that helps decision makers in Egypt to select the best and optimal scenario to retrofit existing buildings factoring in a predefined budget. This model provides a method to manage budget against proposed retrofits taking energy efficiency and return on investment into consideration.

The simulation model is developed using Designbuilder software which depends on different data categories collected from the building preliminary survey, retrofit decision scenario information from interviews with the operations team, energy bill readings, and the relevant building construction technical data. Twelve retrofit measures typically proposed by the Facilities and Operations team were assessed and utilized for the development of the Energy Retrofit Decision Support System (ERDSS) optimization model based on the proposed framework. Using LabVIEW software, the retrofit options are qualified, ranked and optimized according to the highest calculated savings to investments ratios where a case study has been selected from an educational institution at Cairo, Egypt.

The aim of this case study is to examine the applicability of ERDSS and functionality of the simulation model in the context of the budget constraints and technical limitations. An optimum retrofit scenario was recommended by ERDSS analysis, the model prioritized the possible retrofit actions within the allocated budget and according to savings to investment ratio results for each criterion. The results show that the model delivered the expected output and provided the initially forecast plan.

Table of Contents

ACKNOWLEDGEMENTS iii

ABSTRACT iv

Table of Contents v

Chapter 1: Introduction 2

1.1 General background of study2

1.2 Existing buildings conversion to green2

1.3 Building retrofit categories3

1.4 Green retrofitting financial return4

1.5 Problem statement5

1.6 Research objective and scope:6

1.7 Research framework6

1.8 Thesis organization7

Chapter 2: Literature Review 10

2.1 International Experience10

 2.1.1 European retrofit experience10

 2.1.2 Green retrofit experiences in Asia11

 2.1.3 United States retrofit experience11

 2.1.4 Egypt and the green retrofit approach12

2.2 Guidelines and Methods12

 2.2.1 LEED for existing buildings13

 2.2.2 Advanced Energy Retrofit Guides (AERG) for existing buildings14

2.3 Energy retrofit categories16

 2.3.1 Existing Buildings Commissioning (EBCx)16

 2.3.2 Standard retrofits17

2.3.3	Deep retrofit	20
2.3.4	Building energy retrofit outline	21
2.3.5	Major phases in a building retrofit program	22
2.3.5.1	Project setup and pre-retrofit survey	22
2.3.5.2	Energy auditing and performance assessment	22
2.3.5.3	Identification of retrofit options	23
2.3.5.4	Site implementation and commissioning	23
2.3.5.5	Validation and verification	23
2.3.6	Factors affecting the retrofit strategies	23
2.3.6.1	Building characteristics	24
2.3.6.2	Efficiency measures (energy audit)	24
2.3.6.3	Retrofit barriers and innovations	25
2.4	Retrofit Process.....	26
2.4.1	Retrofit planning team	26
2.4.2	Data collection and analysis	27
2.4.3	Energy demand and thermal assessment	28
2.4.4	Economic analysis	29
2.4.5	Financing options	29
2.4.6	Quantitative energy performance assessment method selection	30
2.4.6.1	Energy performance diagnosis:	30
2.4.6.2	Building Management System (BMS)	31
2.4.6.3	Energy bill-based model	31
2.4.7	Retrofit measures selection	31
2.4.8	Tree-structured analysis	32
2.4.9	Retrofit Constraints	33
2.5	Energy Performance Assessment Methods for Buildings.....	33

2.5.1	Existing buildings retrofit technologies	34
2.5.1.1	Supply side management	35
2.5.1.2	Demand side management	35
2.5.2	Retrofit decision support tools and methods	35
2.5.2.1	General retrofitting tools	36
2.5.2.2	Modeling Tools	37
2.5.2.3	Energy improvement and CO ₂ emissions tools	38
2.5.2.4	Economic analysis tools	38
2.5.2.5	Life Cycle Analysis (LCA) tools	38
2.5.2.6	Sustainable assessment systems	39
2.6	Energy green retrofit application methodology	39
2.7	Conclusion	40
Chapter 3: Research Proposed Framework		43
3. Introduction:		43
3.1. Proposed framework		43
3.1.1.	Preliminary survey	45
3.1.2	Building condition assessment	46
3.2. Retrofit alternatives assessment using building energy simulation		46
3.2.1.	Simulation software	47
3.2.2.	Simulation process	48
3.2.3	Simulation baseline case	49
3.2.3.1	Simulation retrofit scenarios	50
3.3 Database development		51
3.3	Model development	55
3.4 ERDSS model structure		56
3.4.3	Dynamic programming approach	57

3.4.4	Model interface	60
3.4.5	Savings-To-Investment Ratio	61
3.4.6	Optimization process and outputs	64
3.5	Conclusion	68
CHAPTER 4: Model Implementation and Validation		70
4. Introduction:	70
4.1. Case Study	71
4.1.1	Assessing building energy performance for diagnosis analysis.....	72
4.1.2	Data collection	72
4.1.3	Pre-retrofit survey	73
4.1.4	Energy Audit, Performance Assessment, and Diagnostics	73
4.1.5	Identification of retrofit scenarios.....	75
4.1.5.1	Building envelope (walls-windows)	76
4.1.5.2	HVAC System retrofit data.....	77
4.1.5.3	Lighting system retrofit actions	78
4.2 Building energy simulation	79
4.2.1	Building energy simulation baseline.....	80
4.2.2	Simulation scenarios	81
4.3 Developing building retrofit measures database	83
4.3.1	Temperature control scenarios	83
4.3.2	Operation schedule scenarios.....	84
4.3.3	LED Lighting fixtures and lighting liner control	85
4.3.4	Windows glass and shading options	86
4.3.5	HVAC system change.....	87
4.3.6	Cost analysis	87
4.4 ERDSS application	88

4.4.1 ERDSS optimization results.....	92
4.5 Conclusion	93
Chapter 5: Conclusions and Recommendations	96
5.1 Summary	96
5.2 Recommendations for encouraging green retrofit	97
5.3 Future Research	98
References.....	99
Appendices.....	103

LIST OF TABLES

Table (2-1) O&M Measure Summary Table	17
Table (2-2) Part of Standard Measure Summary Table	19
Table (2-3) Deep Retrofit Recommended Package	21
Table (2-4) Classification of some building energy software tools	37
Table (2-5) Classification of modeling and optimization tools	38
Table (3-1) Database BMS actual readings versus simulation results	52
Table (3-2) Monthly BMS reading of actual consumption (Part of Database).....	53
Table (4-1) Simulation input data categories.....	74
Table (4-2) Sample of LED lighting cost analysis for SSE	79
Table (4-3) Zones breakdown for energy simulation	81
Table (4-4) Simulation baseline data versus BMS actual readings	84

LIST OF FIGURES

Figure (1-1) Building Resources Consumption Ratio in Egypt.....	2
Figure (1-2) Research framework	7
Figure (2-1) Literature review structure	10
Figure (2-2) Scope of AERGs	14
Figure (2-3) AERG retrofit decision-making process	15
Figure (2-4) Key phases in sustainable building retrofit program	22
Figure (2-5) Integrated Project Team	27
Figure (2-6) Database development four core components	28
Figure (2-7) Tree Structures Diagram for Criteria Analysis	32
Figure (2-8) Energy Quantification Methods for Existing Buildings.	34
Figure (2-9) Classification of Retrofit Decision Support Methods	35
Figure (3-1) The proposed framework	44
Figure (3-2) DesignBuilder building simulation overview	49
Figure (3-3) Summary of Model Application Framework	56
Figure (3-4): Interactive Database Main Components	58
Figure (3-5) LabVIEW Model tree structure	59
Figure (3-6) Building Information Screen ERDSS	61
Figure (3-7) ERDSS Database savings calculation section (LabVIEW).....	64
Figure (3-8) ERDSS Optimization engine (LabVIEW).....	65
Figure (3-9) ERDSS Project optimization report (user interface)	66
Figure (3-10) ERDSS Retrofit scenarios generator (user interface).....	66
Figure (4-1) Model framework	70
Figure (4-2) SSE First floor Plan	72

Figure (4-3) Model tree structure	75
Figure (4-4) SSE Wall section	77
Figure (4-5) SSE window type sample	78
Figure (4-6) SSE building's model in simulation tool.....	81
Figure (4-7) SSE simulation zoning	82
Figure (4-8) Simulation temperature control output	85
Figure (4-9) Simulation operation schedule control output	86
Figure (4-10) Simulation lighting fixtures and liner control output	86
Figure (4-11) Simulation Windows glass and shading options output	87
Figure (4-12) HVAC System modification	88
Figure (4-13) EDRSS Scenario generation	91
Figure (4-14) EDRSS Scenarios	92
Figure (4-15) SSE optimum scenario results from ERDSS	93

LIST OF SYMBOLS

Symbol	Description
AERG	The Advanced Energy Retrofit Guides
ERDSS	Energy Retrofit Decision Support Model
LEED	Leadership in Energy and Environmental Design
ASHRAE	American Society for Heating, Refrigerating and Air Conditioning Engineers
EEBRP	The Energy Efficiency Building Retrofit Program
EGP	Egyptian pound
BAS	Building Automation System
EBCx	Existing Building Commissioning
BMS	Building Management System
H	Number of hours of operating cooling/heating system per year
E_{price}	Price of 1kilo watt hour consumption of electricity
SHARR	Social Housing Action to Reduce Energy consumption
CSF	Critical Success Factors
EPIQR	Energy Performance And Indoor Environmental Quality Retrofit
ACUPCC	The American college & University Presidents' Climate Commitment
Max./Min.	Maximum/ Minimum
MC	Maintenance Costs
MF	Maintenance Factor

LS	Lifetime of the building Service years
IRR	Internal Rate of Return
PV	Present value of the operating costs for the lifetime of the building service
RC	Replacement Cost
SIR	Saving to Investment Ratio
MIRR	Modified Internal Rate of Return
M&V	Measurement and Verification
O&M	Operation and Maintenance
DOE	U.S. Department of Energy
SEED	Standard Energy Efficiency Data Platform
BPD	Building Performance Database
ΔT	Different temperature between outdoor temperature and Indoor temperature

CHAPTER 1

Introduction

Chapter 1: Introduction

1.1 General background of study

The shortage in renewable energy is placing a great pressure on higher education universities. Increased financial pressures on schools pose various operational challenges which can impact the academic process and mission. A number of technical approaches exist to resolve this problem through improving building performance to satisfy a variety of needs of building occupants and achieve the intended mission.

This thesis addresses the energy retrofit challenges for existing buildings and proposes a method to support decision makers in applying the retrofit plan that best meet their objectives.

1.2 Existing buildings conversion to green

Buildings are the most significant contributors to greenhouse gas emissions and energy consumption (Figure 1-1). Buildings are responsible for about 40% of the Carbon Dioxide (CO₂) emissions globally (Asadi et al., 2012). While only a considerable amount of energy is consumed during building construction, a larger share of energy is consumed during the building operations phase and post occupancy (Juan et al., 2016).

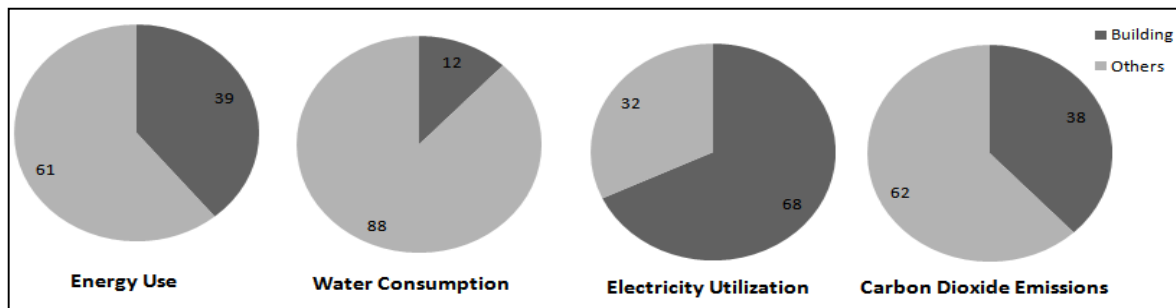

Figure (1-1) Building resources consumption ratio in Egypt (Assad et al. 2015)

In the last decade, the level of community awareness about the value of energy efficiency has begun to reflect the concern about a massive ecological footprint. Greening existing buildings is one approach to tackle this increasing problem. There are many possible options to support a green building approach, such as enhancing both air and water quality, minimizing solid waste generation and developing new technologies and management techniques to better manage the built environment. A review of the literature shows that the costs for maintenance for retrofitted existing buildings decrease by approximately 13% as a result of adopting proper methods and technologies to impact energy consumption and manage resource use. (Tatari & Kucukvar, 2010). Furthermore, lower energy consumption can be achieved through use of passive technologies and alternative renewable energy sources.

At the social level, retrofitted buildings have a positive impact on the lifestyle of building occupants, as they improve work productivity, general health, and well-being. Green retrofits provide bolstered air and water quality, minimize waste, and replace non-renewable energy resources with renewable sources (Duah & Syal, 2016).

A number of studies adopted the principles of green energy retrofit to demonstrate proposed retrofit and provides useful information for prioritizing critical renovation issues (Sailor et al., 2011; Tatari & Kucukvar, 2010).

1.3 Building retrofit categories

There are several types of building retrofit options, the selection of which depends on a building's existing systems, the conditions of each system, and compliance with the codes and specifications. Several studies indicate a projected growth in green retrofitted existing buildings in the coming 20-25 years (Duah & Syal, 2016; Chau et al., 2010). There

are three categories for retrofitting, depending on technical aspects and financial constraints (Liu et al., 2011):

1. Operation and maintenance measures:

This type of retrofit relies on enhancing the operation process by achieving the maximum utilization of the existing building systems with minimal modifications of the building operation management and with low-cost impact.

2. Standard retrofits

It is considered the second category of retrofit which targets replacing parts of the existing systems. The building operation team assesses the suggested retrofit measures and selects the targeted measures with minimal interference with building operation schedule.

3. Deep retrofits

This category of retrofit is used in major retrofit projects that need a change in the building function, or upgrading building operation systems to new updated equipment and technologies and is usually associated with large budgets.

1.4 Green retrofitting financial return

Greening existing buildings provides a precious opportunity for economic stimulus and risk resilience in an increasingly resource-scarce world, and is the lowest-cost option to a low-carbon future. Green retrofit has an impact on a country or region's building stock; reduces dependency on risky and imported energy sources; lowers harmful emissions; reduces strain on existing infrastructure; and serves as a catalyst for job creation.

As a result of rapid changes in renewable energy use worldwide, especially in building technology through systems technology updates and code changes, green building changes have become a must, especially for developing countries like Egypt. Green retrofitting has already proven its economic, social, financial, and environmental benefits

worldwide. For the next decade, developing countries should develop plans for green retrofitting and should start to use new energy systems and tools to create a whole new generation of high- performance buildings.

1.5 Problem statement

Existing buildings consume a large segment of the total current energy production especially in developing countries like Egypt. Increasing energy demand coupled with decreasing energy resources has encouraged existing building green retrofit trend to maximize the energy performance of the built environment (Jaggs & Palmer, 2000). This trend is primarily focused on: improving deficient insulation, reducing the inefficiency in heating and cooling systems, utilizing advanced construction materials and techniques to maximize efficiency (EEDC, 2015), and advancing the quality of building management systems (Menassa, 2011).

Existing building retrofit plan should investigate several factors that include: building condition, current operating schedule, system efficiency, energy rates, targeted savings, occupants' needs, and available retrofit budgets (Wang et al., 2012). These different factors present different variables with multiple criteria that affect the decision-making process and have a reciprocal impact on each other. Accordingly, there was a need to identify each variable by weight to calculate the measure impact on the final retrofit decision. Decision-makers are often burdened with a large number of decision variables that have to consider in order to select the optimum retrofit option plan for their existing buildings with a budget limitation to perform only the most efficient measures that can achieve the highest energy saving with the least initial cost. This generated the need to a decision support tool that can help to prioritize different retrofit measures to identify the optimum retrofit scenario within a specific budget.

1.6 Research objective and scope:

The objective of this research is to:

1. Encourage green energy retrofit approaches in Egypt.
2. Simulation modeling to test the different retrofit actions Impact and to construct the local library database.
3. Develop a decision support model to help decision-makers to recommend optimum retrofit scenario within specific budget.

1.7 Research framework

The framework employed in this research is as follows, Figure (1-2):

4. Literature review stage: covering the topics such as green energy retrofit for existing buildings, technical assessment methodologies, and available green retrofit simulation tools.
5. Data collection stage: including technical and cost data of individual retrofit measures, climatic data, buildings system, and their costs.
6. Impact analysis stage: where the impact of each retrofit measure on building energy performance is identified and the expected savings after applying certain retrofit actions are estimated.
7. Database development stage: where all relevant data are combined in order to create a comprehensive database for system application.
8. Energy retrofit design support model (ERDSS) development: that estimates building energy rates and consumption, after applying the needed retrofit level, with various alternatives to meet the occupant needs. Decision-makers can use ERDSS-based

selection of best alternatives, which is based on budget allocation considerations, priority assessment, energy demand, and user preferences.

9. Validation stage: where the model output is validated using a case study.

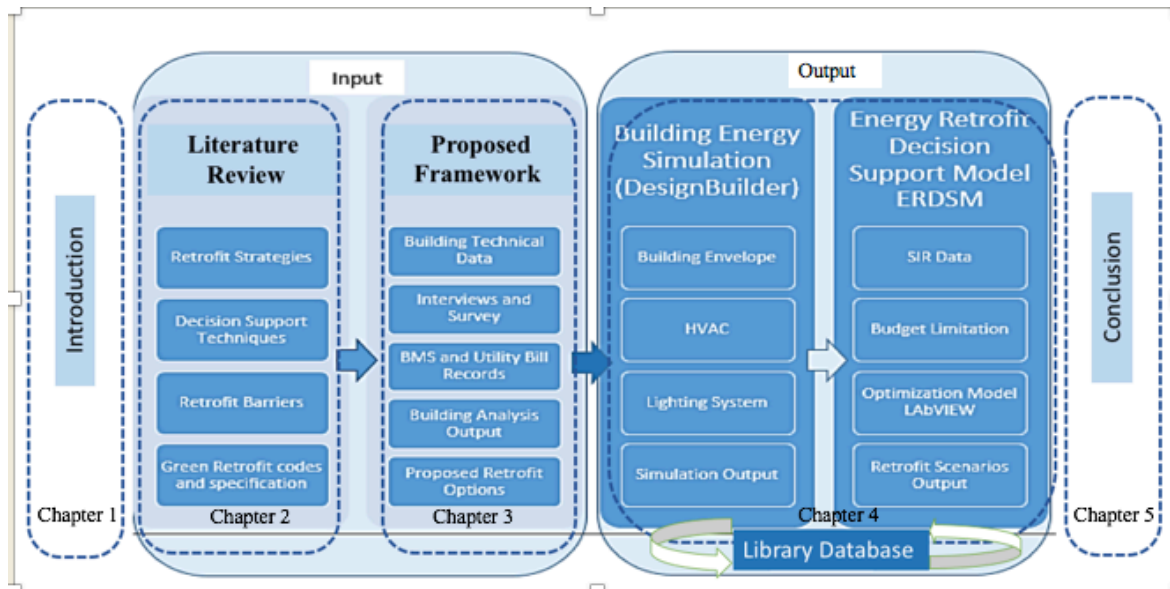

Figure (1-2) Research framework

1.8 Thesis organization

This thesis is composed of five chapters as listed below:

Chapter 1: Is an introduction of green energy retrofit schemes for existing buildings, and a presentation of research structure, methodology, scope and objective.

Chapter 2: Is a review of the literature regarding: green energy retrofit schemes for existing buildings, international experiences, energy retrofit categories, guideline/ methods for existing buildings green retrofit, design concepts and assessment methods. Chapter 2 also includes a review of available green retrofit simulation /optimization tools for existing buildings.

Chapter 3: Is a discussion of retrofit technologies, decision support methods, and the common tools for conducting retrofit assessments to identify proper approaches for energy-saving, green retrofit models for existing buildings. It also shows the proposed energy assessment framework and illustrates the methodology for green retrofit for existing educational buildings, which uses a measurement based method tied to building management system (BMS) actual readings.

Chapter 4: Presents results of the implementation of a case study and detailed data analyses through building simulation software adapted on an existing educational building. The selected case study is one of campus buildings for one of the universities in Egypt.

Chapter 5: Shows research summary and conclusion, as well as recommendations for future research.

CHAPTER 2

Literature Review

Chapter 2: Literature Review

This chapter discusses recent research on energy retrofit for existing buildings, current international experience, energy retrofit categories in addition to major phases for developing a building retrofit program. The chapter also covers different methods used for energy performance assessment for existing buildings (Figure 2-1).

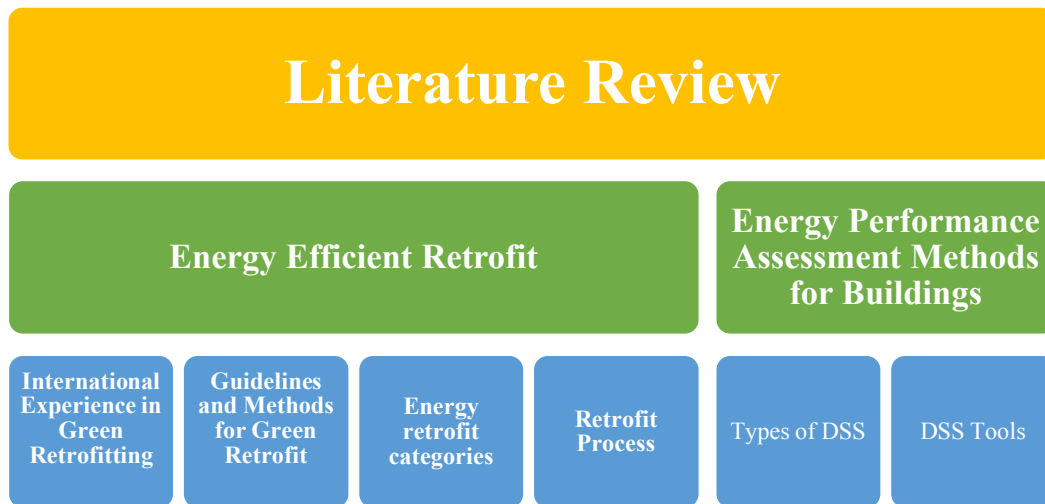

Figure (2-1) Literature review structure

2.1 International Experience

Developed countries implemented the concept of green retrofit for existing buildings, which produced efficient measures for retrofitting in different buildings categories. Newly developed energy retrofit codes were then included as part of general building codes. Governmental plans include energy efficiency goals, and programs to increase green awareness and motivate building owners toward green retrofit schemes (Duah & Syal, 2016).

2.1.1 European retrofit experience

The proportion of retrofitted buildings in Europe started at 1980 and increased by 40% in year 2013. With the support of research conducted to investigate the expected

benefits of upgrading residential buildings, potential savings are expected to reach up to 80% from the assigned energy for heating by 2020 (Arias, 2013)

The Social Housing Action to Reduce Energy Consumption (SHARR), started in nine European countries, with the aim to support energy saving solutions. It facilitated getting loans to encourage building owners to invest in retrofitting (Chau et al., 2010). Other countries started to adopt the passive house concept, which depends on prioritizing passive systems for heating and cooling as a part of building design and operation. As a part of the European Union's agenda for the future of existing buildings, a certification system for European retrofit standards, the Energy Performance of Building Directive (EPBD) was established (D'Agostino et al., 2017).

2.1.2 Green retrofit experiences in Asia

In Asia the growth in the economy and population caused a growing demand on energy, putting great pressure on governments to meet market demand. Existing buildings are responsible for approximately 28% of the total of energy consumption (Wang et al., 2012). Most of Asian countries addressed minimizing energy consumption through green retrofit for existing buildings in their main economic agendas within their development plans (Arias, 2013).

2.1.3 United States retrofit experience

The United States construction industry is considered the highest energy consuming sector in the world (Stadler et al., 2014). Many institutions and large-scale companies have started to apply new operation techniques to achieve energy savings for all their facilities. The level of sustainability awareness has increased, evidenced by the figures shown in educational institutions, private companies, and public-sector institutions dedication of special budgets for the development of energy-efficiency programs in their facilities.

Energy Efficiency Building Retrofit Program (EEBRP) was launched in 2007 and it supports a large number of buildings to overcome the complications of retrofit and market barriers (Stadler et al.,2014). EEBRP invited a group of experts from different organization (i.e. energy-saving firms, financial institutions, and governmental representatives) to design an advanced energy retrofit guide for existing buildings. This guide can help institutions to assess the costs and benefits of various financing options early in the project development process (Arias, 2013).

2.1.4 Egypt and the green retrofit approach

Recognizing that green retrofit plays a major role in supporting the country's future energy plans, the Ministry of Electricity and Renewable Resources launched a number of new electricity-generating plants that use renewable resources (MEREAR, 2015).

Existing building green retrofit initiatives in Egypt still have many uncertainties to overcome the challenges and the needed energy savings with respect to the allocated budget. Many retrofit approaches have long payback periods and is difficult to quantify the benefits of the green retrofit. The shortage of original existing-building design data and operational information is a major obstacle. Building performance, user feedback, thermal comfort, and environmental aspects are all factors that are required to identify the appropriate depth level of analysis (Menassa, 2011).

2.2 Guidelines and Methods

One of the most used rating systems around the world is the Leadership in Energy and Environmental Design (LEED), which is evaluating existing buildings operation and maintenance schemes.

2.2.1 LEED for existing buildings

The LEED rating system is a commonly referenced system in the United States. It is a point-based assessment system developed and maintained by the USGBC to provide the means to measure a building's sustainability level using universally accepted standards and methodologies, and often uses cost and quantities as prime determinants. It is a sustainable building rating or assessment system, not a building standard.

LEED for Existing Buildings Operation and Maintenance sets an evaluation benchmark to certify the operation and maintenance of existing buildings of all types and sizes. It mainly addresses 7 main categories:

- Sustainable Sites (SS)
- Water Efficiency (WE)
- Energy and Atmosphere (EA)
- Materials and Resources (MR)
- Indoor Environmental Quality (IEQ)
- Innovation in Operations (IO)
- Regional Priority (RP)

The LEED main target is to encourage owners and operators of existing buildings to implement sustainable practices. The rating system specifically addresses exterior building site maintenance programs, water and energy use, environmentally preferred products and practices for cleaning and alterations, sustainable purchasing policies, waste stream management, and ongoing indoor environmental quality (United States Green Building Council, 2009).

Many countries work within the LEED system as a guiding source for local rating system development (such as Egypt's experience with the Green Pyramid rating system) by

taking into consideration different weather conditions and available resources. The increasing numbers of successful retrofitting experiences have helped to summarize the retrofit detailed process in specialized guides.

2.2.2 Advanced Energy Retrofit Guides (AERG) for existing buildings

The U.S. Department of Energy (DOE) developed AERG to provide useful information to building owners, and facility managers to enable them to select the energy efficient improvements that better suit their building type and location, as shown in Figure (2-2). Emphasis is put on actionable information, practical methodologies, diverse case studies, and objective evaluations of the most promising retrofit measures for each building type (Liu et al., 2011).

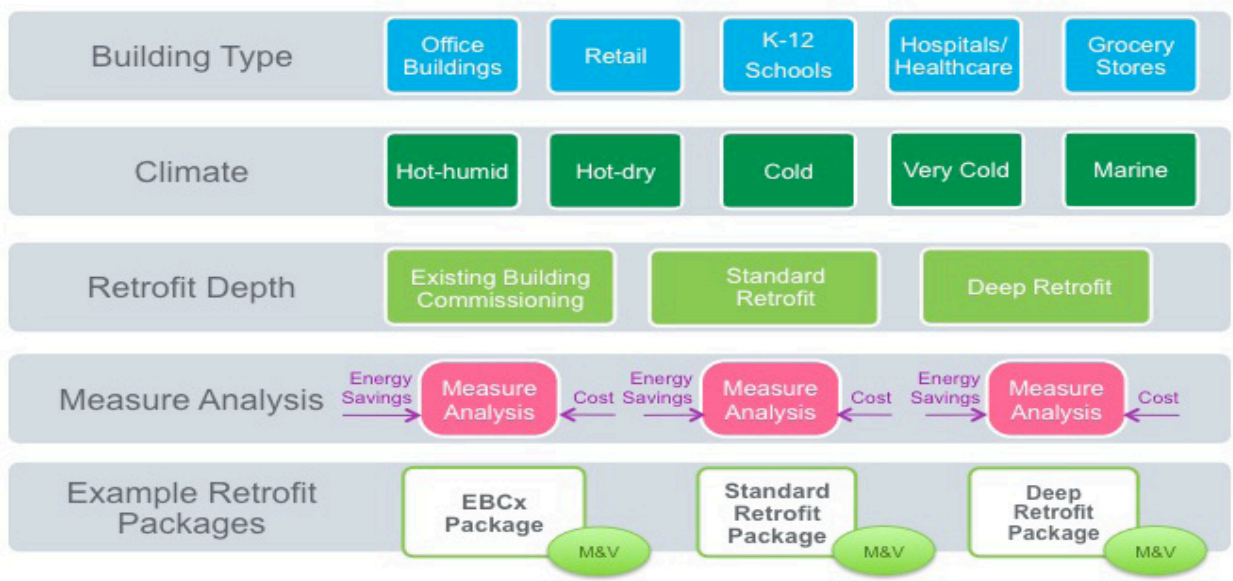

Figure (2-2) Scope of AERGs (Liu et al., 2011).

There are many barriers in applying the green retrofit, mainly due to operators' challenges to get started due to limited resources.

Building owners and facility managers need to know whether they should improve operation and maintenance through the existing commissioning system, or standard retrofit, or go directly to the deep retrofit stage. AERG team discusses a large number of possible retrofit options in detail. It illustrates all stages of upgrade through different case studies that address many relevant variables and retrofit decision-making process (Figure 2-3).

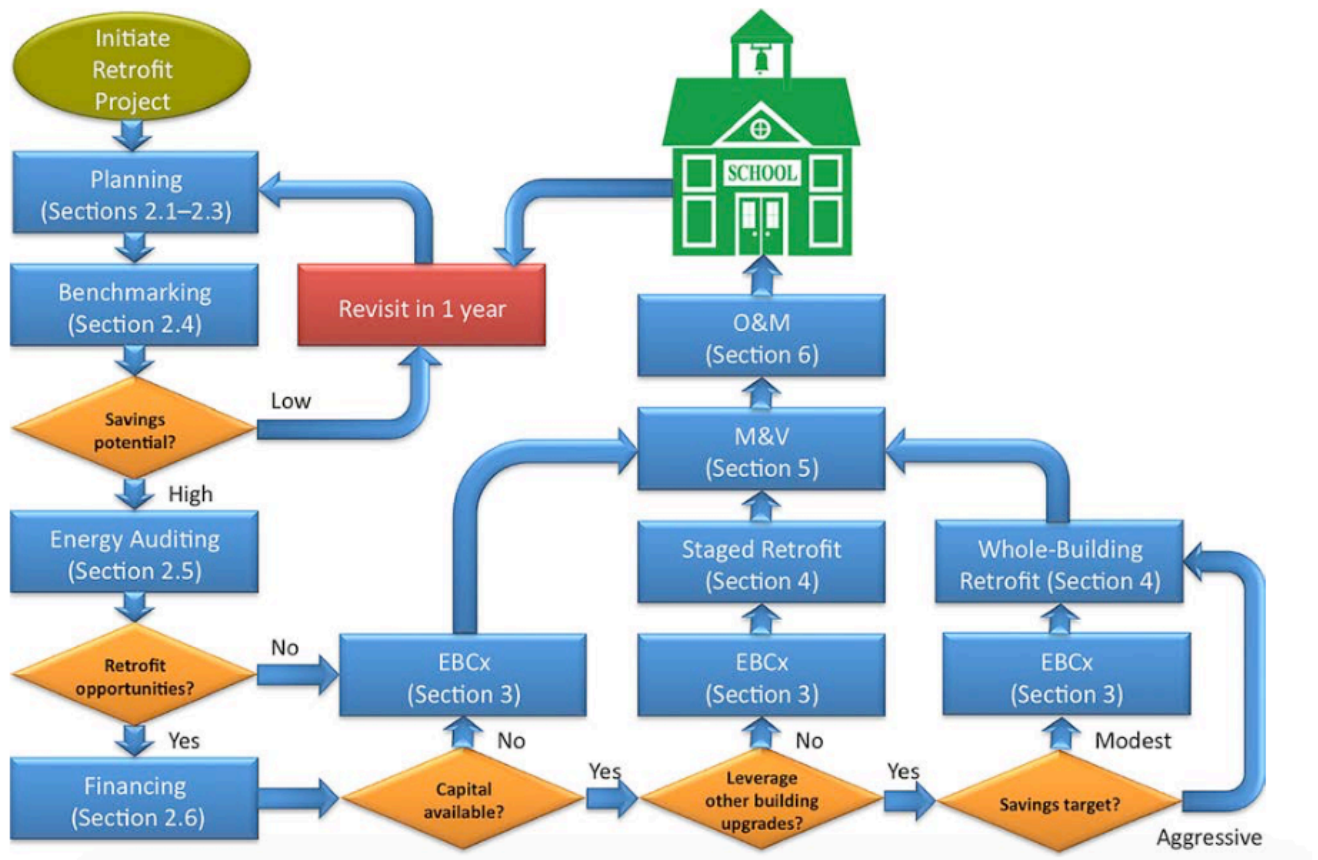

Figure (2-3) AERG retrofit decision-making process (Liu et al., 2011).

Even though AERG has successfully developed three levels of upgrade through analyses of databases that are derived from combined case studies of buildings, these models are most usefully considered as guides to new retrofit, as every building has different characteristics and a unique nature (Liu et al., 2011).

The retrofit process first step is collecting building data to perform the needed analysis for all potential retrofit measures. The next step is arranging the selected options based on their priorities for the building occupants and operation requirements. Technical feasibility is the main factor at this stage. Next, there must be a detailed analysis for each measurement to assess associated energy savings and cost-effectiveness. These analyses will provide the basic data for the next stage, which is finalizing the selection of the most effective package of measures that will bring about the best cost and energy savings results.

2.3 Energy retrofit categories

The term “retrofit” is commonly applied to any type of energy-efficiency improvement opportunity, no matter what others changes may have occurred. As previously mentioned, according to AERGs for existing buildings, there are three types of retrofits (Moser et al., 2012):

1. Existing Buildings Commissioning
2. Standard retrofits
3. Deep retrofits

2.3.1 Existing Buildings Commissioning (EBCx)

Researchers have shown that EBCx retrofits can achieve good savings with minimal risks through quality-oriented processes that enhance building performance. This is dependent on identifying the existing system features for determining the best scenario for using all resources in the most efficient way. It is a basic step in all types of retrofit, as it assumes that O&M measures are implemented. This type of retrofit process is usually divided into four steps:

1. Planning
2. Investigation

3. Implementation

4. Hand-off

The previous four steps are recommended for a retrofit process, as it allows the retrofit team to go impact the building at different levels and provide the best solution with minimal cost. AERGs listed most of the retrofit actions that are applicable to minimal cost scenarios, Table 2-1. Nevertheless, there are many factors that can affect cost effectiveness for this type of retrofit, such as (Liu et al., 2011):

- High level of unjustified energy use
- High failure rate of building equipment or control systems
- Digital controls
- Inexperienced in-house staff
- Building documentation and updated data

2.3.2 Standard retrofits

The standard retrofit provides more options for upgrade than the buildings commissioning retrofit, and assumes medium risk (Moser et al., 2012),but is still cost-effective, which helps owners with limited capital investment options to improve their buildings efficiency. In some cases, a standard retrofit may involve “like-for-like” retrofits by using equipment with a capacity similar to that of the existing systems, but with updated technology (Table 2-2). Standard retrofits can be done in phases depending on the sequencing for selected measures.

Table (2-1) Buildings Commissioning Measures Summary Table (Liu et al., 2011)

System	Measure Number and Description	Applicable To				
		Hot & Humid	Hot & Dry	Marine	Cold	Very Cold
Lighting	L1. Calibrate exterior lighting photocells	O	O	O	O	O
Envelope	E1. Replace worn out weather stripping at exterior doors	O	O	O	O	O
	E2. Reduce envelope leakage	RP	RP	RP	RP	RP
HVAC Air Side	HA1. Revise air filtration system	RP	RP	RP	RP	RP
	HA2. Increase duct system efficiency	O	O	O	O	O
	HA3. Calibrate air sensors	RP	RP	RP	RP	RP
	HA4. Re-enable supply air temperature set point reset	RP	RP	RP	RP	RP
	HA5. Reduce HVAC equipment runtime, close outside air damper during unoccupied periods	RP	RP	RP	RP	RP
	HA6. Remove unused inlet guide vanes from supply fan inlet	O	O	O	O	O
	HA7. Reduce economizer damper leakage	O	RP	RP	RP	RP
	HA8. Implement a night purge cycle	O	O	O	O	O
HVAC Water Side	HW1. Inspect chiller and cooling tower, clean as needed	O	O	O	O	O
	HW2. Test and fix chilled and heating water coil valves	O	O	O	O	O
	HW3. Inspect and repair damaged pipe insulation	O	O	O	O	O
	HW4. Calibrate water sensors	RP	RP	RP	RP	RP
	HW5. Re-enable chilled water supply temperature set point reset	O	O	O	O	O
	HW6. Shut down cooling plant when there's no cooling load	RP	RP	RP	RP	RP
Other	O1. Implement daytime custodial services	O	O	O	O	O
RP = measure is part of recommended package O = measure is not part of recommended package but is an option						

Table (2-2) Part of Standard Measure Summary Table (Liu et al., 2011)

System	Measure Number and Description	Applicable To					Stage (see Section 2.5)	Appendix Page # Ref.
		Hot & Humid	Hot & Dry	Marine	Cold	Very Cold		
HVAC Air Side	HA12. Lower VAV box minimum flow setpoints (rebalance pneumatic boxes)	RP-S	RP-S	RP-S	RP-S	RP-S	3	161
	HA13. Widen zone temperature deadband, add conference room standby control (upgrade to DDC zone control)	RP-D	RP-D	RP-D	RP-D	RP-D	3	163
	HA14. Lower VAV box minimum flow setpoints, reset duct static pressure (upgrade to DDC zone control)	RP-D	RP-D	RP-D	RP-D	RP-D	3	165
	HA15. Add demand-controlled ventilation	RP-D	RP-D	RP-D	RP-D	RP-D	3	167
	HA16. Replace supply fan motor and Variable Frequency Drive (VFD)	RP-D	RP-D	RP-D	RP-D	RP-D	3	168
	HA17. Change HVAC system type	O	O	O	O	O	4	170
HVAC Water Side	HW7. Shut down heating plant when there's no heating load	RP-D	RP-D	O	O	O	4	170
	HW8. Increase efficiency of condenser water system	O	RP-D	O	O	O	4	172
	HW9. Increase efficiency of condenser water pumping system	RP-D	RP-D	O	O	O	3	173
	HW10. Change cooling plant pumping system to variable primary.	RP-D	RP-D	O	O	O	3	175
	HW11. Replace cooling and heating plant pump motors	O	O	O	O	O	3	177
	HW12. Add a VFD to one chiller	RP-D	RP-D	O	O	O	4	178
	HW13. Add waterside economizer	O	O	O	O	O	4	179
	HW14. Add chilled water plant heat recovery	O	O	O	O	O	4	180
	HW15. Replace boilers and change heating plant pumping system to variable flow primary	O	O	RP-D	RP-D	RP-D	4	181
	HW16. Replace boiler burners with modulating burners	O	O	O	O	O	4	183
	HW17. Increase the efficiency of the tenant server room pumping system	O	O	O	O	O	3	184
HW18. Cool the server rooms with transfer air instead of mechanical cooling	O	O	O	O	O	3	185	
HW19. Increase the efficiency of the tenant server room cooling units	O	O	O	O	O	3	186	
SHW	S1. Increase efficiency of service hot water system	O	O	O	O	O	N/A	187
Other	O2. Retrofit electric transformers with higher efficiency models	O	O	O	O	O	N/A	189

RP-S = measure is part of standard retrofit recommended package
 RP-D = measure is part of deep retrofit recommended package
 RP-S&D = measure is part of standard and deep retrofit recommended package
 O = measure is not part of recommended package but is an option

2.3.3 Deep retrofit

This type of retrofit is considered the best opportunity for owners to reduce their energy consumption rates and achieve the largest saving ratio. Deep retrofit requires a concurrent evaluation of all systems. Table 2-3 shows deep retrofit recommended scenarios for lighting, envelop and HVAC system. It also needs to involve proper simulation software to work with all needed analyses (Liu et al., 2011; Moser et al., 2012).

There are many opportunities in a building's lifetime that can lead decision-makers to choose the deep retrofit option, such as:

1. Life of major equipment in the operation systems nearing its end
2. Changing part or all of the building envelope
3. Major design changes to meet occupant's needs
4. Targeting green certificates, which will make deep retrofit more economical (Moser et al., 2012).

However, decision-makers must consider a very important factor in selecting the type of retrofit to implement which is: whether the building will be partially occupied or totally clear during the retrofit. On the other hand, the savings resulting from a deep retrofit can be expected to be 45% of the current operation energy consumption (Moser et al., 2012).

After decision-makers have a technical vision of such changes, they can start integrated design and planning for retrofit execution.

This approach is most useful during the initial stages of a retrofit project. It can stimulate ideas for additional retrofit EEMs, describes important performance and cost tradeoffs, and identifies reliable and cost-effective M&V protocols. Table 2–3 shows how each section fits into the general process of upgrading existing educational building.

Table (2-3) Deep Retrofit Recommended Package (Liu, G et al., 2011)

System	Measure Description
Lighting	L2. Retrofit interior fixtures to reduce lighting power density by 11%
	L6. Install occupancy sensors to control interior lighting
	L7. Add daylight harvesting
	L8. Retrofit exterior fixtures to reduce lighting power density, and add exterior lighting control
Envelope	E7. Add roof insulation
HVAC - Air Side	HA13. Widen zone temperature deadband, add conference room standby control (upgrade to DDC zone control)
	HA14. Lower VAV box minimum flow setpoints, reset duct static pressure (upgrade to DDC zone control)
	HA15. Add demand-controlled ventilation
	HA16. Replace supply fan motor and VFD
HVAC - Water Side	HW7. Shut down heating plant when there's no heating load
	HW8. Increase efficiency of condenser water system
	HW9. Increase efficiency of condenser water pumping system
	HW10. Change cooling plant pumping system to variable primary.
	HW12. Add a VFD to one chiller
	HW15. Replace boilers and change heating plant pumping system to variable flow primary

2.3.4 Building energy retrofit outline

For a retrofit, there are several unforeseen factors that must be considered, such as the condition of existing construction materials, technical constraints in selecting new options for replacements, building skeleton conditions, and the current operation systems failure pattern. This is the reason that the retrofit must start with analysis and assessment, to be followed by a comprehensive energy audit that evaluates the available building data to

identify energy saving opportunities for the current operation system. This must include investigating any possible steps to help occupants change behavior and the allocated cost for the retrofit. Whatever the selected approach for the retrofit, the vital factor is making sure that all systems are installed properly and are functional (Arias, 2013). The retrofit process must go through specific phases as shown in Figure (2-4).

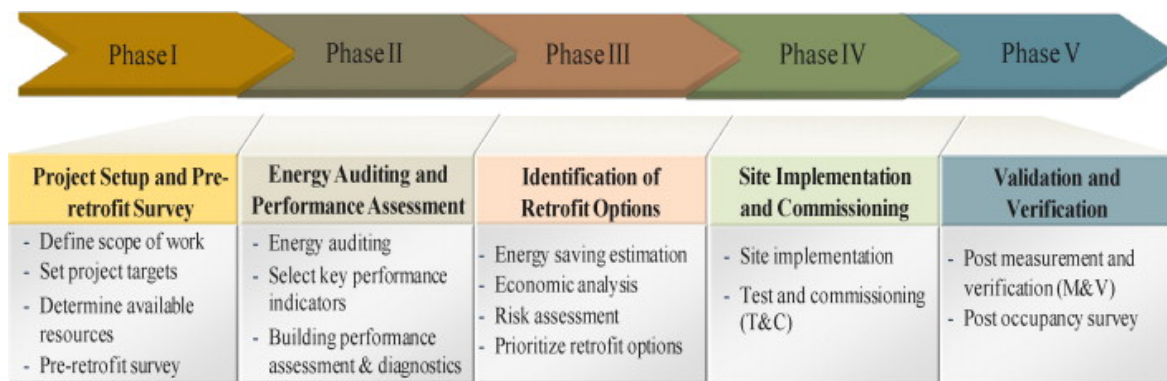

Figure (2-4) Key phases in sustainable building retrofit program (Zhenjun et al., 2012)

2.3.5 Major phases in a building retrofit program

2.3.5.1 Project setup and pre-retrofit survey

The first step in the building retrofit is conducting a pre-retrofit survey, in order to assess the building condition and to identify future needs for building occupants to set these requirements as project targets. This helps in defining the scope of work and to assess the available recourses and needed budget.

2.3.5.2 Energy auditing and performance assessment

This phase targets analysis of building energy use and costs to: clarify the energy waste reasons, compare building performance with the targeted benchmark, and perform an energy audit to identify potential areas of improvement.

2.3.5.3 Identification of retrofit options

Economic analysis takes place after using an appropriate energy calculation method, in order to clarify the targeted range of retrofit designs and the options to achieve them. The selected alternatives should be prioritized according to their energy-saving impact and investment cost.

2.3.5.4 Site implementation and commissioning

The execution plan should make sure that all retrofit selections are operating with the best practices with minimum disturbances for the building occupants.

2.3.5.5 Validation and verification

After retrofit implementation, actual operation verification of all measures, energy savings and performance should be calculated.

An overall assessment of processes should be performed, including their compliance with targeted codes. All relevant data should also be added to a database to facilitate decision-making in the current project, and to help in any upcoming similar projects (Zhenjun et al., 2012).

2.3.6 Factors affecting the retrofit strategies

Main systems, subsystems, and materials have high influence in building efficiency performance. The retrofit challenge is, how can less energy be used without reducing the level of building performance? Each building presents a different type of energy consumption situation, with variably efficient technologies. The following retrofit phases of building energy assessment, or energy audit, will identify the appropriate work plan. The work plan depends on many factors such as economic criteria,

preferred funding source, and implementation energy-performance contract. Lastly, the project phase-out must be taken into consideration.

Many studies have summarized the main factors that affect the building retrofit decision these includes (Junghans, 2013):

- Building characteristics
- Efficiency measures
- Energy performance assessment
- Barriers and innovations
- Cost allocation and budget priority

2.3.6.1 Building characteristics

Building retrofitting depends on the level of available building information. It is necessary to identify the building history including: the location, orientation, year of construction, history of operation, systems information, equipment lifetime, and last date of renovation.

2.3.6.2 Efficiency measures (energy audit)

Energy audits can vary from one project to another, depending on the depth of assessment; however generally, it can be performed as follows:

- Walk through assessment
- Energy survey and analysis
- Detailed energy analysis

The selection of the audit level depends on the level of available information about the building's energy consumption, operating systems, retrofit targets, and potential retrofit approaches. For existing buildings, the most common approach is to measure energy data. (Zhenjun et al., 2012).

2.3.6.3 Retrofit barriers and innovations

There are many owners and decision-makers who face real challenges and barriers in retrofitting their buildings. The challenges are similar to those in new building construction, but more complicated. The challenges start with the design team, with their hopes of acquiring higher end of retrofit techniques and systems while facing budget constraints, user requirements, implementation time constraints, and technical limitations and obstacles. All previous factors lead to searching for more contemporary solutions for design treatment.

The high level of uncertainty in the retrofit process has resulted in a large number of owners avoiding the retrofit option. A survey of 750 building owners to identify the reasons for avoiding green retrofit found that the high initial cost of construction retrofit was the main objection (61%), followed by the long payback period (57%), and owners' inability to identify the benefits of retrofitting (43%) (Menassa, 2011).

A lack of experienced human resources to form a complete team of architects, engineers, and contractors, to develop an appropriate retrofit plan also increase the risk level for retrofit projects. If the building is to be occupied during the retrofit, it will take very specific scheduling and strategy to work around the occupants (Miller, 2015). Therefore, we can summarize that the main barriers for green retrofits as follows:

- Uncertainty about the effectiveness of the chosen retrofit approach
- Shortage of building records and information
- Long payback periods
- A failure to use best practice strategies

- The cost of retrofit, which ultimately falls on the building owner, while benefits affects the tenants and should be reflected in the rent contracts
- Other variables causing uncertainty, including government policy changes, and change in energy prices.

All the above factors have a direct impact on the decision of selecting the proper retrofit technology and techniques rather than financial benefits being the single axis for the decision-making. Thus, it is a combination of all factors including economic, environmental, energy, social, technical, and regulatory. Critical Success Factors (CSF) for energy efficiency in retrofit projects include (Zhenjun et al., 2012):

- Human factors
- Client resources and needs
- Retrofit technologies
- Regulations and policies
- Unique building information and environmental aspects
- Economic factors

Social /cultural factors (Zhenjun et al., 2012; Lee et al., 2015)

2.4 Retrofit Process

The retrofit process must consider all the above factors in order to help decision-makers determine the best retrofit option to be selected. In addition, the trade-off between retrofit costs and energy savings must also be taken into account in order to develop an appropriate analysis of the designated retrofit options (Jaggs & Palmer ,2000).

2.4.1 Retrofit planning team

A team of the retrofit professionals should be formed to: study the possible scenarios of retrofitting, survey the building's condition, and decide on priority areas. Team members

should include various operations discipline to achieve the ultimate goal trough collecting all the possible building information and report it to retrofit design team leader (Figure 2-5).



Figure (2-5) Integrated Project Team (Jaggs & Palmer ,2000)

2.4.2 Data collection and analysis

Sustainable building retrofit requires investigating existing systems and checking if they operating at optimum levels or not, before considering replacing existing equipment with new higher-efficiency equipment. Conducting surveys and interviews with building operators and occupants is a good way to assess equipment performance, in addition to studying materials and equipment datasheets, and deterioration code. Developing a database of all building components and their performance will help in obtaining a comprehensive list of needed work during the building’s lifetime. It will also help in prioritizing the retrofit decision and developing action plans. The database should include four core components: building information, construction elements, costs and location as shown in (Figure 2-6).

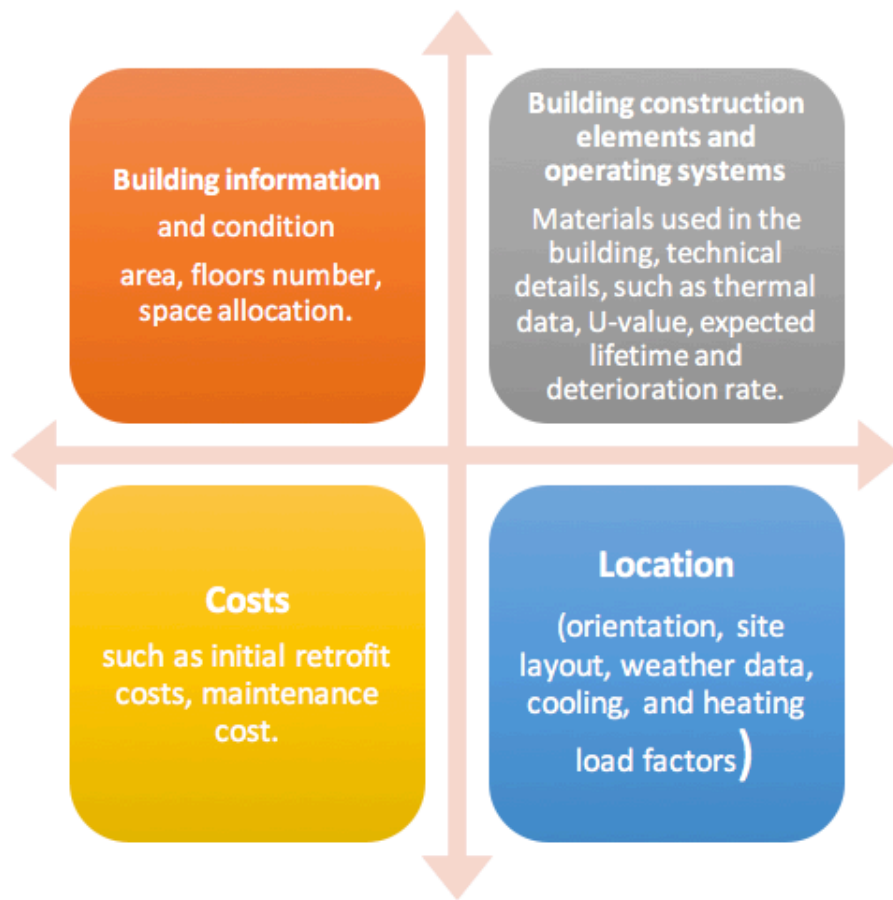

Figure (2-6) Database development four core components (Jaggs & Palmer ,2000)

2.4.3 Energy demand and thermal assessment

The target is to identify the needed cooling/heating loads that can achieve the thermal comfort for building occupants. Many factors have a direct impact on the building thermal assessment, such as envelope heat gain/loss. Therefore, the retrofit team should determine the airtightness of the building envelope by examining the envelope, roof, windows, and conduction through walls. These factors are the main consideration in the energy demand calculations to reduce energy loss and to measure the real needed energy (electricity, gas) in order to maintain an acceptable level of indoor air quality, proper ventilation and thermal comfort.

2.4.4 Economic analysis

The selection of the retrofit type is a comparison of the needed capital investment and the planned benefits to be achieved. The economic analysis facilitates the comparison as it helps to select the most appropriate, cost-effective alternative, through the use of different methods. It presents the analysis and comprehensive assessment of the noted retrofit measures. The prices of energy and of energy-efficient technologies are vitally important in determining which measures to be applied as “savings to investment rate” and and expected payback period are based on energy price.

2.4.5 Financing options

In a number of developed countries, there is a set of financing options available only to energy-efficiency projects. These additional options include energy performance contracts, utility rebates, on-bill finance programs, and government-supported low interest loans. A variety of tax incentives further improve the economics of energy-efficiency upgrades (Chau et al., 2010; Lee et al., 2013). The energy performance goal and action plan must align with the available financing options and match the life cycle cost, as it is calculated based on the initial, operating, replacement, and maintenance estimations of the system. The cost selection should not only depend on the value of the current investment, but also on many other factors, such as the payback period and the savings to investment ratio. It also reflects the net present value against inflation rates for energy prices (Mahlia et al., 2010). For highly beneficial results, there are some issues that need to be addressed in the planning phase regarding the preferred approach of decision-making and financial analysis. This includes, for example, the target criteria the project needs to meet (economic

and technical benchmarks) considering the depth of the project retrofit analysis (Paumgarten, 2003).

2.4.6 Quantitative energy performance assessment method selection

Energy Performance Assessment Methods (EPAM) for existing buildings techniques are used according to the assessment scope and depth. EPAM serves two main purposes, energy classification and energy performance diagnosis (Wang et al., 2012).

2.4.6.1 Energy performance diagnosis:

It provides different levels of details for faulty diagnoses at a system level. Concerning existing building calculation assessments, there are discrepancies in comparing the measured actual readings and predicted consumption rates. This can result in a lack of credibility for the chosen assessment method. Thus, while new buildings depend solely on calculation-based methods for estimating future consumption, existing buildings can use calculation-based approaches or measurement-based approaches to produce reliable measures. (Oree et al., 2015)

Calculation-based approaches depend on the availability of detailed design data, utility bills or BMS monitoring system reports, end-use sub-metering, audit data, and computer simulation software to perform building modeling and provide a simulated prediction of building consumption rates. **Measurement-based approaches** reflect actual building consumption patterns that depend on the real building performance, and measure the actual use of building systems and occupant behavior. Accordingly, this approach experiences fewer constraints and more credibility (Wang et al., 2012).

2.4.6.2 Building Management System (BMS)

The BMS depends on building actual operation readings before and after applying the retrofit actions. The BMS can provide a clear picture of the weight of each system on overall building energy use. It is also acceptable for multi-phased retrofit projects to follow up the change pattern for each retrofit action, especially for operational retrofit actions. BMS reflects the energy consumption savings and can perform as an operational saving measure by controlling the building operation schedule to reflect actual operation demand (Zhenjun et al., 2012).

2.4.6.3 Energy bill-based model

Regarding buildings that do not have BMS, the energy bill method can be a very useful technique for determining current consumption. The energy bill is a highly accurate energy measurement method, which is readily available in most existing buildings. Monthly bills provide sufficient information about the building energy performance within an acceptable level of accuracy. Measuring each system's weight is a bit more complex when all systems are connected to one meter that measures overall building consumption. In this case, system weights can be determined by turning off each system separately, reading the difference in energy readings on the meters, and comparing it to the overall consumption rate. After identifying each system's weight, the larger consumer systems is identified.

2.4.7 Retrofit measures selection

With respect to technical constraints and budgetary limits, retrofit measures should be selected based on all building assessment results to achieve minimum cost and maximum energy savings. The criteria selection depends on the three main pivots of sustainability: environmental, sociocultural, and economic.

Building operation activities consist of heating, cooling, building ventilation, lighting, equipment operation, and water heating. The selection of retrofit variables depends on the building's condition and needs. Usually, the increased flexibility created by being able to select from a greater range of retrofit actions improves the probability of achieving the best energy savings with better environmental impact (Rosenfeld & Shohet, 1999).

2.4.8 Tree-structured analysis

After selecting an experienced team and collecting all available building data, a tree-structured analysis should be performed (Alanne,2003) (Figure 2-7). The first level of the diagram represents the main goal, which is to achieve the optimum retrofit. The second level represents the main criteria and objectives (building main systems HVAC, lighting, building envelope). The next level deals in detail with actual retrofit measures, such as energy consumption for each system, operation hours, and thermal comfort standards. The lowest level of the tree is an indicator of clear numerical factors for various system components, such as lighting systems, fixtures, lamps, automation systems, and motion detectors. Theoretically, there is no limit on the number of criteria for each evaluation process. However, research recommended that the number of criteria in each level of the tree under the main goal should not exceed 8 nodes (Alanne,2003). Each criterion should have a weight indicator because each criterion has an influence on the decision-making process. The grading method is simple to use, from grades 1 to 10, and each weight can be determined and should be applied on each level in the tree (Duah & Syal, 2016).

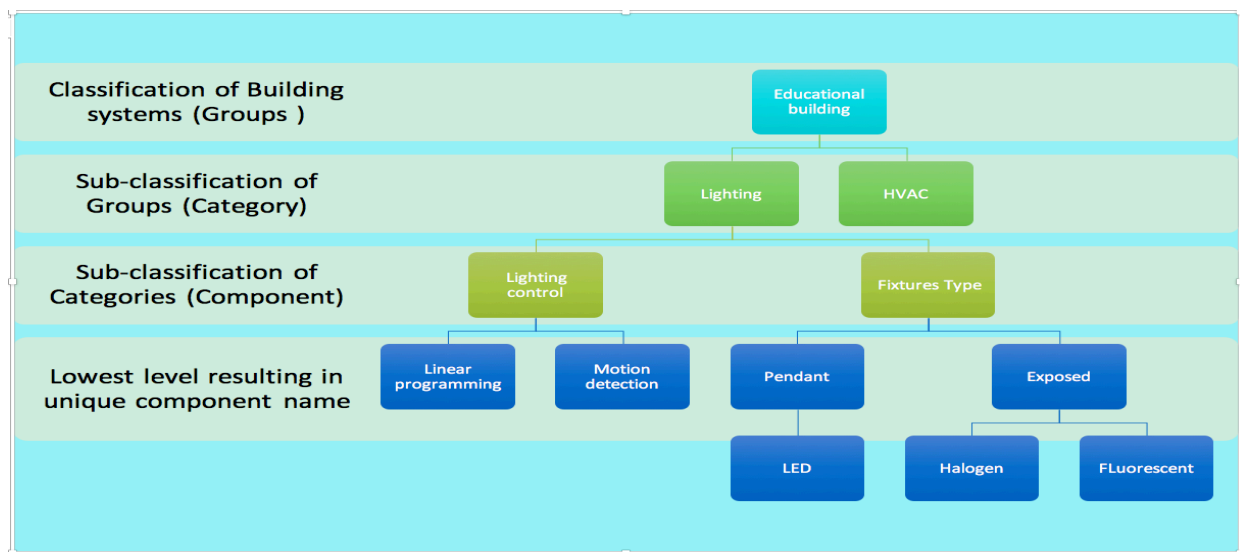

Figure (2-7) Tree Structures Diagram for Criteria Analysis (Alanne ,2003)

2.4.9 Retrofit Constraints

There are many constraints on the building retrofit process, these vary depending on the building case, and include:

- Compatibility constraints (selection of the most appropriate actions to be carried out)
- Budget constraints (size of allocated budget)
- User requirement constraints (need to achieve the required performance)
- Building specific constraints
- Other constraints (law, social conditions, and regulations)

2.5 Energy Performance Assessment Methods for Buildings

Energy performance assessment investigates how relevant parameters will be defined and assessed, and how much energy can be targeted at a minimum rate of consumption while still meeting building occupant needs. This type of assessment can be divided into two categories: performance-based and feature-specific (Wang et al., 2012).

Performance-based analysis: assesses building energy performance using quantitative methods to enable comparison with assessment criteria. Energy quantitative

methods can be categorized into calculation-based, measurement-based, and hybrid methods (Wang et al., 2012).

For existing buildings, the most widely-used energy assessment methods are calculation-based procedures and measurement-based quantification. (Figure 2-8) shows the different energy quantification methods.

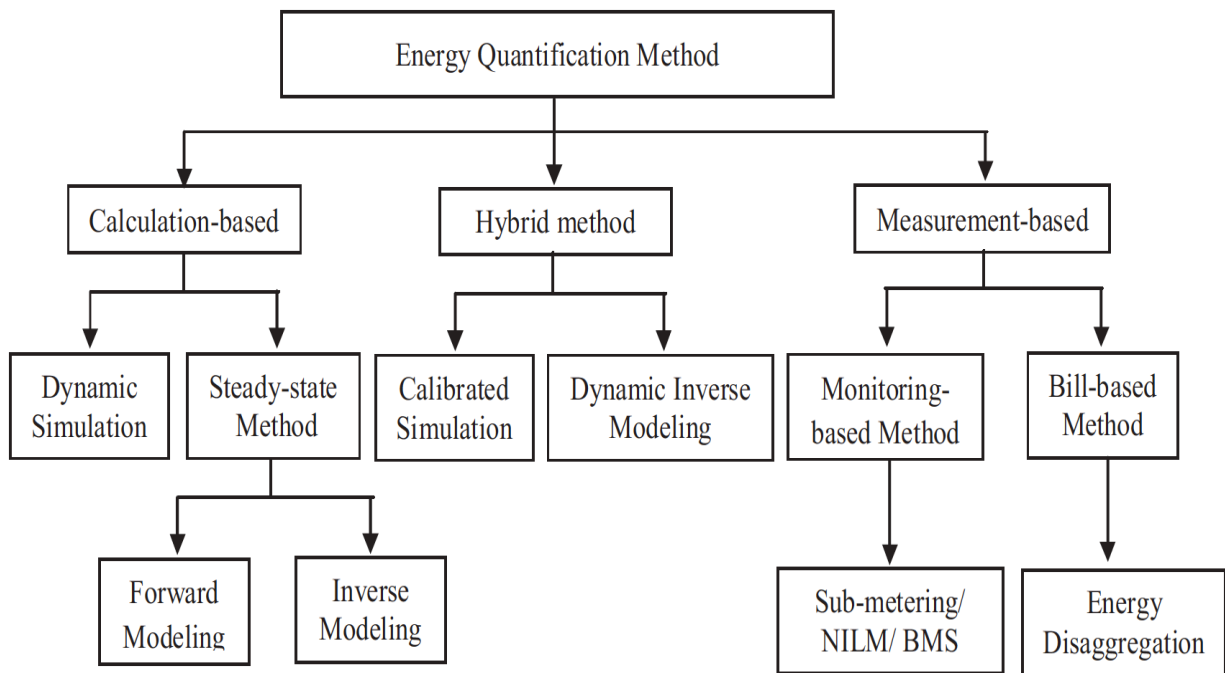

Figure (2-8) Energy Quantification Methods for Existing Buildings (Wang et al., 2012)

2.5.1 Existing buildings retrofit technologies

Main retrofit technologies have been categorized to: supply side management and demand side management depending on the selected retrofit methodology.

2.5.1.1 Supply side management

Supply Side Management involves changing buildings' electrical systems to use renewable energy resources (solar powered systems, water heating or photovoltaic for energy supply, wind energy, etc.)

2.5.1.2 Demand side management

Demand side management involves reducing the buildings' heating and cooling demand within the current energy resources and available systems. Improvement starts with improving current equipment performance to minimize consumption and prevent building envelope leakages. Ultimately, old systems may be replaced and updated within the same building operation method (Chau et al., 2010).

2.5.2 Retrofit decision support tools and methods

The available decision-support tools or components in the retrofit process need to be managed by a skilled team who develops the selection rationale. This will involve several trade-off analyses between technical conflicting objectives (Figure 2-9). Most of the commonly used techniques for existing building energy retrofit involve multi-criteria decision-based methods, simulation-based approaches, or a combined approach. Preferably, the DSS will contain:

- A mathematical model that covers the logical and physical relations and which is dependent on the level of available building data.
- Tools used to support the needed comparative analysis of the core model.



Figure (2-9) Classification of Retrofit Decision Support Methods (Ferreira et al., 2013)

There are more than 40 different tools available to support decision-making, all centering on different criteria, and which may be summarized into five groups according to common aims and targeted objects (Ferreira et al., 2013):

- General tools
- Modeling tools
- Energy improvement and CO₂ emission tools (environmental perspective).
- Economic analysis
- Life cycle analysis (LCA) tools
- Sustainable assessment tools

2.5.2.1 General retrofitting tools

General tools incorporate all the methods that can match different project case situations and are flexible to meet client needs. Such methods include multivariate design and multi-criteria analysis, and calculation of the building utility cost, identification of the refurbishment priority, and selection of the optimal solution. Methods range from single-objective to multi-objective criteria. General methods contain different criteria that make

the tool flexible enough to be applied to a wide range of cases, with quantitative evaluation to be performed by a professionally experienced team. (Table 2-4) shows summary about some available building energy software tools (Scheuer et al., 2003; Asadi et al., 2012; Ferreira et al., 2013)

Table (2-4) Classification of some building energy software tools

	COMBAT	GREAT	Target finder	EDGE	Retrofit Savings Estimator	BEopt
Aim	To help estimate energy savings from buildings retrofit.	To track energy production and consumption.	Buildings Energy performance analysis	To help calculate energy savings of a green building.	To help building owners and others quickly evaluate the potential energy savings associated with existing retrofit strategies	To identify optimally efficient designs for new and existing homes at the lowest possible cost
Target audience	Policy-makers and experts	Policy-makers and experts	Experts	Policy-makers and experts	Commercial building owners, managers and tenants	Researchers and energy analysts
Approach	Interactive	Interactive	Interactive	Interactive	Interactive	Interactive optimization
Scope	Project	Policy	Project	Project	Project	Project
Stage of PD cycle	Implementation, Tracking	Scoping, Tracking	Implementation; Tracking	Implementation; Tracking	Retrofit planning	Retrofit optimization

2.5.2.2 Modeling Tools

Modeling and optimization tools are very important to enable the retrofit design team to perform needed technical retrofit analyses, especially for new green systems which are not commonly used. Modeling tools consider all the probabilities of improvement and thereby are able to identify the optimum environmental and economic options. Modeling tools are split into two categories as shown in Table 2-5 (Ferreira et al., 2013):

- Accounting and Simulation tools
- Optimization tools

Table (2-5) Classification of modeling and optimization tools

General Modeling Tools						
Accounting and simulation tools				Optimization tools		
Type	Software	Design data	Operation concept	Software	Design data	Operation concept
Accounting	RETScreen	Excel-based	Payback analysis	Homer	Windows- based program	Financial Analysis
Simulation	Tanys's	Modular programing	SO Called "types"	EnRiMa	Modular programing	Multi – objective decision support system
Simulation	Energy Plus	Windows, Mac And Linux	Thermo dynamic equations	DER_CAM	General Algebraic Modeling System (GAMS)	
Simulation	Energy Plan	Windows based	Analytical programming			

2.5.2.3 Energy improvement and CO₂ emissions tools

Energy and CO₂ analysis tools quantify the thermal energy needed throughout the operational and execution phase of the building retrofit. Determining the environmental impacts through life cycle cost analysis can be supported by software such as TOBUS and EPIQR which are an interactive decision aid tools for building retrofit (Ferreira et al., 2013).

2.5.2.4 Economic analysis tools

The focus of economic analysis is financial savings, while minimally accounting for environmental impacts. This type mainly aims to reduce the cost of retrofit for both the execution and the operation phases (Ferreira et al., 2013).

2.5.2.5 Life Cycle Analysis (LCA) tools

Life cycle analysis is a common technique used for environmental assessment. Cost measuring tools are indispensable, given most buildings' long lifetimes. These tools

consider all the retrofit aspects, including energy use, CO₂ emissions, health impact, cost, environmental aspects, and social issues during building assessments.

2.5.2.6 Sustainable assessment systems

There are internationally recognized systems such as Leadership in Energy Environmental Design (LEED) and other certified rating systems, which depend mainly on a point system for assessment. The assessment is based on reducing environmental impact Energy, carbon and cost.

2.6 Energy green retrofit application methodology

The retrofit plan is a structured process that starts with the proper strategic planning, through the selection of retrofit type and the tools used for implementation. The process is implemented through the following steps (Jaggs & Palmer ,2000):

- Identifying occupant and operator requirements, through interviews and preliminary surveys
- Testing the building's physical and operational conditions
- Performing a technical assessment survey and evaluating energy readings
- Performing an advanced assessment if the preliminary assessment does not meet the minimal score compared to the targeted benchmark, which includes: comprehensive energy readings and assessment, economic analysis, cost estimation, payback period analysis, and risk assessment.
- Determining if the priority is on cost or quality.

Dependent on the selection priority in the previous step, the other criteria must be considered in the selection of the retrofit measures but with smaller weights. Setting the

retrofit selection criteria as the main priority, the decision-makers consider many constraints varying from one building to another. The major constraint will control the main retrofit criteria whether it will be budget based or target a specific level of quality to fulfill particular certificate accreditation requirements.

After collecting the needed data and selecting the retrofit technology and tools, the observed results will provide decision-makers with the sufficient information needed to make a final decision. Also, the results can be used to develop a database to answer questions for a similar scenario in future cases.

If the results do not meet initial user requirements, retrofit team can change their preferences and go back to the analysis stage to go through the process once more with a different perspective.

The final report can either be generated from the modeling tool directly, or it can be combined with different analytical stages (energy consumption rates before the retrofit and after the retrofit with calculated savings, cost of retrofit-selected options, and expected benefits of the changes).

2.7 Conclusion

A global trend to adopt the concepts of building energy retrofit for existing buildings is spreading world-wide. This chapter provides a literature review for the varying efforts in green building retrofit research. It also discusses retrofit processes, including planning, data collection, possible financing options, quantitative energy performance assessment, and application methodology (supply side management, demand side management, and classification of decision support methods).

Throughout the process of selecting the retrofit technologies and modeling tools, many factors need to be considered. These include the level of available data and nature of

retrofit priority (cost, schedule and budget). Each selection will reflect the choice of building analysis systems and modeling tools used. Also, each factor will impact the type of building assessment system selected for the retrofit, taking into consideration that given constraints will likely control the plan. Retrofit methodology will help the retrofit team to be organized, facilitate the flow of the retrofit plan, and prepare the adequate data for decision-making.

The retrofit cycle depends on proper planning, data collocation for all the technical available data, the application of comprehensive assessment for meeting the thermal comfort for the space function, while searching for the best possible financing options. It was shown that breaking down the retrofit options according to the retrofit tree structure model is useful to classify the different criteria levels. It is especially useful in order to weigh each measure's impact and prioritize decision scenarios accordingly.

After conducting the literature review research and identifying the research gap, which is the need for decision support tool that help the decision makers in identifying the optimum retrofit scenario within the allocated budget. Therefore, there is a need for a tool that can prioritize the retrofit options according to the expected maximum energy savings with respect to budget constraints. This type of tools also can help in the budget planning matrixes for building operation and upgrade future plans.

CHAPTER 3:

Research Framework

Chapter 3: Research Framework

3. Introduction:

In this chapter, the green retrofit framework will be illustrated to present a plan for reaching the best retrofit scenario within the allocated budget. The proposed framework shows the approach to select the retrofit option, outlines the building energy simulation and explains the steps for developing the prototype decision-support system.

3.1. Proposed framework

Figure (3-1) shows the proposed framework for the energy green retrofit DSS where it consists of five main modules:

- Preliminary survey
- Building evaluation
- Testing retrofit alternatives impact using building energy-simulation software
- Database development
- ERDSS (Energy Retrofit Decision Support System) development

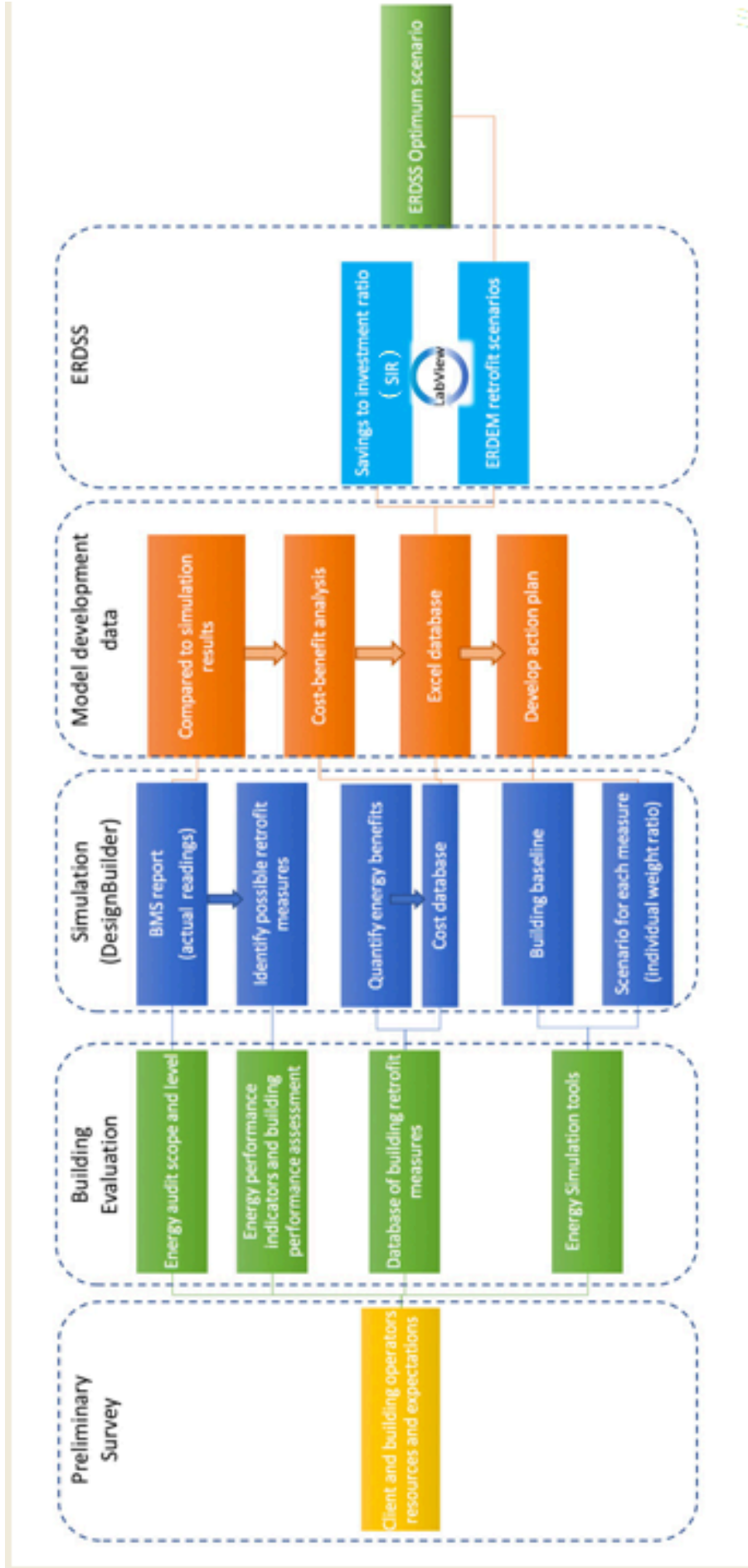

Figure (3-1) The proposed framework

3.1.1. Preliminary survey

The first module is the preliminary survey, serves to collect all relevant building information to be included in the database. It acts as the baseline of current building conditions, which is to be compared with energy readings after retrofit implementation. Data collection includes interviews with the building operations team (a pre-retrofit survey) to identify the targeted improvement areas, in addition to studying the building design and construction documents, and updating the prices of retrofit measures from vendors in the local market. The collected information gathered in the database consists of four main components: building location information, construction elements, costs, and building operation data.

Building location information includes: relevant information about Cairo, Egypt, such as weather data, monthly average ambient temperatures, and cooling load factors.

The construction elements database consists of three main systems that have an impact on building energy consumption, which are (1) the building envelope information, (2) HVAC System, and (3) lighting systems, schedule, equipment, intensity, etc. Each system contains lists of different construction materials and related information, such as technical and thermal data. Actual data for building envelope includes: material thickness, conductivity, U-value, Sola Heat Gain Coefficient (SHGC), initial retrofit costs, and energy consumption rates. Building information to the building under study includes: total area, number of floors, height of floors, number of windows, and glazing percentage.

Cost-related data includes: the initial costs of the retrofit, as well as economic data (interest rates and inflation rates).

Building operational data is collected from the building operations reports. It includes: temperature set points and daily operation hours in regular operating days, and for

weekend and vacations. Regarding building energy consumption rates, there are many measurement-based methods that exist. These include the BMS-based and energy bill-based method. Both are the frequently used for existing buildings retrofits. The selection of a method depends on whether the building has a BMS system or simply uses the readings from the energy bills.

3.1.2 Building condition assessment

After generating the building information database, performance evaluation and energy audit takes place in order to assess system conditions and efficiency. These measures are used to identify areas of needed improvement from an operations perspective. This evaluation should also consider occupant needs for improvement. A technical evaluation is conducted for each system by the building operation team to identify the weak points for each system and ways to enhance its current performance with operational measures to minimize the standard or deep retrofit in order to reduce the retrofit budget.

3.2. Retrofit alternatives assessment using building energy simulation.

Essentially, simulation modeling is an emulation of the real building or system's operation over a specified time period. It draws on information input by the model's creator, with historical database built into the simulation software. The model calculates the scenarios selected by the simulation creator. The outputs are results of the selected alternatives, the quality of which depends on input level details. The aim of using the energy simulation is to identify the weight of each retrofit measure and its impact on the retrofit scenario to calculate the predicted building savings in energy consumption and cost. The simulation input information is based on the building information database, which is developed from the building information survey. It is a combination of design data, as-built drawings, material submittals, and equipment data sheets. The simulation model is divided

into three systems: the building envelope, the HVAC, and the lighting system. These three are the main systems that impact building energy consumption.

The building is assessed to identify its condition and overall annual energy consumption. Then, a breakdown of building systems is performed with tree structure analysis. Each system is assessed individually to identify the weight ratio of each system to the overall energy consumption, and to determine potential improvements areas. The next step is detailed analysis of system elements using energy simulation software, where all building operation information are kept fixed except the one to be tested. Each retrofit measure is tested individually to figure out its impact on the overall system. For example, during simulation one scenario will be testing the impact of only changing all the lamps to LED while keeping all other building systems as the baseline data. This generates a number of retrofit scenarios for each system, with a number of variables and estimated costs. The consideration of all systems produces a large number of retrofit scenarios, generating a large number of variables.

3.2.1. Simulation software

The simulation software used is an integrated modeling suite that includes the EnergyPlus simulation engine, certification, and code compliance module. It is a comprehensive dynamic thermal analysis tool that offers all that can be used for comfort and energy analysis. It is an integrated set of high-productivity tools that assist in sustainable building design. It is used to gain insight into the impact of building design strategies on building environmental performance. This ensures that retrofit design solutions meet performance targets in the early design stages.

3.2.2. Simulation process

This phase of simulation depends on two different databases. The first is the detailed building database, which is developed through previous retrofit analysis. Each simulation module contains a detailed database with a large number of user options. The database is filled out with all the technical data for the selected option. The options are easily edited, so if users do not find the needed criteria, they can customize it. Building simulation modules must contain the following:

1. **Building location data:** This includes the country, city, and the weather data files.
2. **Layout Module:** This enables the user to draw the building geometrically with its actual dimensions, all building data (floor plans, walls thickness, openings), and building orientation. The building is divided into blocks to be able to add special information individually, in order to achieve a high level of accuracy (Figure 3-2).
3. **Building activity:** This contains information about the type of building operation, the functionality of the space, and the occupant operation schedule.
4. **Construction material:** This contains all information on building envelope material (walls, insulation, roof thickness, layers, etc.).
5. **Openings:** This contains relevant information on openings, such as windows and glazing type, glazing percentage to the overall elevations area, shading, and doors).
6. **Lighting:** This contains all building lighting data (fixture type, fixation, lux, natural lighting, etc.)

7. **HVAC:** This contains building system breakdown data (equipment, temperature set point, heating system data, cooling system data, operation hours' schedule, etc.)

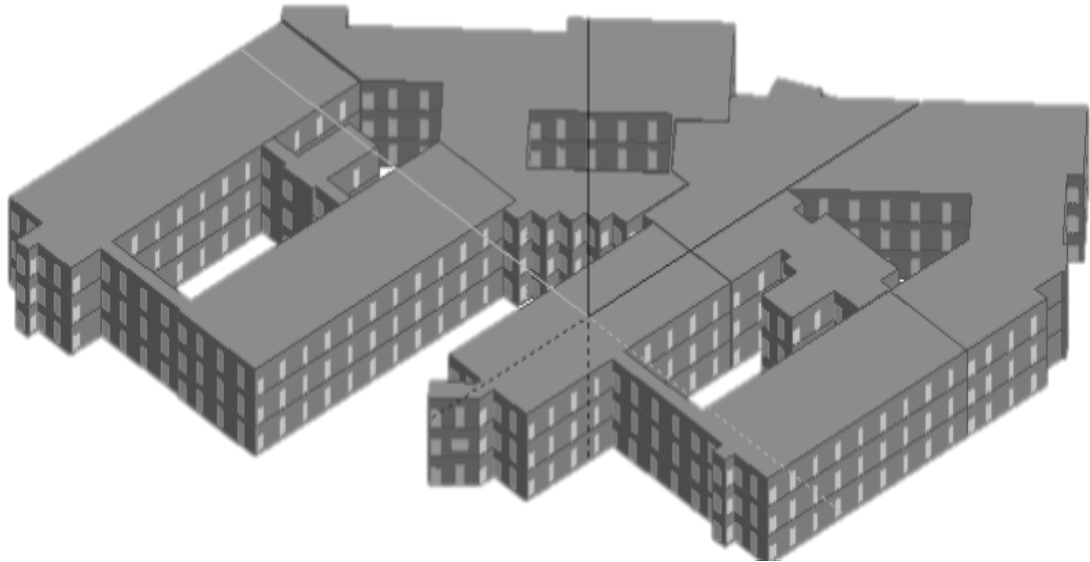

Figure (3-2) DesignBuilder building simulation overview

3.2.3 Simulation baseline case

The first input data scenario on DesignBuilder is the building's condition before retrofit, which is the baseline for building operation. It reflects the actual pattern of occupant behavior, operation schedule, temperature set point, and information on all existing building materials and systems. The annual overall energy consumption generated from the simulation is compared with the actual annual energy consumption reading from the building energy bill (in the case of energy bill method) or compared with the annual energy consumption reading of BMS. The difference in energy consumption readings between the simulation model and actual readings is considered the simulation factor of error, and will be considered during testing all retrofit scenarios (appendix A).

3.2.3.1 Simulation retrofit scenarios

After performing the preliminary building survey and defining the potential areas of improvement, the retrofit team will identify the applicable retrofit measures. There are a number of factors that constrain the selection for each retrofit category, such as the nature of applicable measures, the available budget for retrofit, projected timeframe, and the occupancy size of the building. These factors must be considered during the simulation. Nevertheless, each building has a large number of possible energy retrofit measures that can be implemented.

The next step of the simulation is to test the impact of each retrofit measure individually. The impact of changing a given measure is assessed in different retrofit scenarios, by varying only that measure in the simulation while holding all other input measures constant. The simulation calculates the expected energy savings and can be used as an indication of the estimated financial savings over the lifetime of each retrofit design.

The following equations are applied to calculate the expected savings:

$$S_x = O - O_x \quad \text{Eq. 3-1}$$

S_x: is the expected annual saving kWh

O: is the overall annual consumption kWh (baseline)

O_x: Consumption after applying retrofit measure kWh

$$SC_x = S_x * E_r \quad \text{Eq. 3-2}$$

SC_x: is the expected annual cost savings LE/ kWh

S_x: is the expected annual saving kWh

E_r: is the energy unit rate LE

$$W = S_x / O * 100 \quad \text{Eq. 3-3}$$

W: is Weight of measure impact percentage on overall consumption

S_x: is the expected annual saving kWh

O: is the overall annual consumption kWh (baseline)

All simulations results are combined into an excel database as a preparatory step for future use.

3.3 Database development

Database development is considered the collection point for all previous step results. It combines all the collected information in one pool in order to set the basis for Energy Retrofit Decision Support System (ERDSS) development. Therefore, it contains the comparison results between the annual energy consumption simulation output and the actual annual energy consumption measured using BMS reading and energy bills records. In order to identify the factor of error between simulation output and building consumption actual readings. The database also includes the weight ratio calculations for each retrofit measure to identify each measure impact on the overall energy consumption of the building along with the calculation of the expected savings, each zone activity, operation schedule, temperature set points, and initial cost and life time for each retrofit measure. (Table 3-1) shows example of the database developed for educational buildings.

Table (3-1) Database BMS actual readings versus simulation results

Baseline Summary 2012 actual			
Baseline	Week Days	Week End	
SSE Labs (Baseline)	7.30 :20.00	Off/ Friday	
SSE Offices (Baseline)	8.00 :20.00	Off/ Friday , Saturday	
SSE Classes (Baseline)	7.30 :20.00	Off/ Friday , Saturday	
Temperature set point	Baseline		
Cooling Set point	22		
Heating Set point	20		
Baseline year	Actual Annual Readings	Simulation Annual Readings	Factor of error
Over All 2012	13,367,293.00	14,883,375.20	10%
HVAC (Turnoff test)	55%	59%	
Lighting (Turnoff test)	25%	31%	
Others	20%	10%	
Baseline Summary			
Baseline	Week Days	Week End	
SSE Labs (Baseline)	7.30 :20.00	Off/ Friday	
SSE Offices (Baseline)	8.00 :20.00	Off/ Friday , Saturday	
SSE Classes (Baseline)	7.30 :20.00	Off/ Friday , Saturday	
Temperature set point	Baseline		
Cooling Set point	24		
Heating Set point	21		
Baseline year	Actual Annual Readings	Simulation Annual Readings to meet design	Factor of error
Over All 2012	13,367,293.00	15,498,607.03	14%
HAVC (Turnoff test)	55%	59%	
Lighting (Turnoff test)	25%	31%	
Others	20%	10%	

Table 3-2 shows a sample the building’s annual actual consumption data, as exported from BMS operation reports (or recorded from monthly energy records).

Table (3-2) Monthly BMS reading of actual consumption (Part of Database)

	Chilled Water Energy [kWh]	System1 incoming 1 [kWh]	System1 Incoming 2 [kWh]	System2 Incoming 1 [kWh]	System2 Incoming 2 [kWh]	Total Current
12/31/11	92444	90389	182559	116481	154910	636,783.00
1/31/12	75002	91973	179561	108475	134910	589,921.00
2/29/12	84863	90716	172744	106308	140850	595,481.00
3/29/12	94687	93532	173492	116714	145812	624,237.00
4/29/12	340572	81977	158901	106762	129939	818,151.00
5/29/12	861792	86206	186564	114169	158977	1,407,708.00
6/29/12	1106384	77121	176796	106785	139701	1,606,787.00
7/29/12	1249213	77687	169109	101626	135192	1,732,827.00
8/29/12	881214	70871	147114	80658	120056	1,299,913.00
9/29/12	923014	76713	165947	97864	131307	1,394,845.00
10/29/12	825848	84538	168887	104614	146433	1,330,320.00
11/29/12	825848	84538	168887	104614	146433	1,330,320.00
	7360881					13,367,293.00

After comparing the building's overall energy consumption simulation data with the BMS actual readings, the following equations identify the simulation factor of error to be considered within the model calculations:

$$\mathbf{B_A/B_{SR}} = \mathbf{F_E} \quad \text{Eq. 3-4}$$

Where, **B_A**, Building actual annual readings kWh

B_{SR}, Building simulation annual readings kWh (Baseline)

F_E, Factor of error

The expected energy annual saving after applying retrofit measure can be calculated in kWh as follow:

$$\mathbf{B_S - B_{M1}} = \mathbf{S_{M1}} \text{ in kWh} \quad \text{Eq. 3-5}$$

Where, **B_S**, Building simulation annual readings kWh (Baseline)

B_{M1}, Building simulation annual readings after measure 1 kWh

S_{M1}, Measure 1 annual savings kWh

Resulting simulation savings multiplied by the factor of error:

$$\mathbf{S_{M1} * F_E = P_{M1}} \quad \text{Eq. 3-6}$$

Where, **S_{MI}**, Measure 1 annual savings kWh

F_E, Factor of error

P_{MI}, Predicted annual savings for measure 1 kWh

Energy consumption per m² is equal to total energy consumption divided by the total area.

$$\mathbf{B_A/T_A = E_c/m^2} \quad \text{Eq. 3-7}$$

Where, **B_A**, Building actual annual readings kWh

T_A, Building total area m²

E_C, Energy consumption per m² kWh/m²

Building total actual energy consumption after applying retrofit measure 1 is divided by the total area to calculate the revised energy consumption per m²:

$$\mathbf{B_{MI}/T_A = E_{MI}/m^2} \quad \text{Eq. 3-8}$$

Where, **BA**, Building actual annual readings

TA, Building total area m²

EC, Energy consumption after applying measure 1 per m² kWh/m²

Finally, predicted annual savings for measure 1 is divided by Building actual annual readings to identify the weight ratio for measure 1

$$\mathbf{P_{MI}/ B_A = W_{MI} \%} \quad \text{Eq. 3-9}$$

Where, **P_{MI}**, Predicted annual savings for measure 1 kWh

BA, Building actual annual readings kWh

W_{MI}, weight ratio for measure 1

The Excel database contains all the results of applying each measure individually. This provides the ERDSS framework with all the needed information about the selected measure to facilitate cost calculation relevant to square meter area to be adapted to different

building areas. It also contains the estimated initial cost for each measure. Cost data collected from the local market depends on actual price quotations and vendor price lists.

A large number of applicable retrofit measures and constraints generate a number of scenarios for the retrofit. The large number of variables creates the need for a model that can accommodate the amount of data which results from the different simulation scenarios, all to be collected into the excel database. In optimization, the model helps decision-makers select the optimum scenario for a retrofit within the allocated budget.

3.3 Model development

The large number of possible retrofit scenarios, under varying constraints, such as limited budgets and time frame, often mean that models and optimization tools become essential for building owner and operator retrofit decisions.

The ERDSS is developed to support decision makers in selection an optimal scenario for campus building green retrofit. It considers the annual energy calculations from the building energy simulation software, and uses it to compare the effect of different retrofit measures on educational buildings. It tests the performance of each measure under the three main categories of building envelopes, taking into account HVAC and the lighting system. The Savings-to-Investment ratio (SIR) cost approach is used to measure the savings through the building life cycle and is used to compare the performance of the measures. It also indicates the expected energy savings and financial benefits over the life of the retrofit measure. ERDSS uses SIR as a ranking tool to help the prioritization process of selecting the optimal green energy retrofit scenario.

3.4 ERDSS model structure

An ERDSS model following the proposed framework was developed. The model structure used LabVIEW (Laboratory Virtual Instrument Engineering Workbench), which is a development environment based on a visual programming language called G. Unlike, C, C++, Java etc., there is no script involved in the development process, but rather, graphical function nodes connected through wires. However, it includes the capability of integrating MATLAB, C or C++ code into the LabVIEW source code. In the current research application, MATLAB code is integrated into LabVIEW. The advantage of using LabVIEW in this application is the graphical user interface, which is called "Front Panel", which uses an Excel database input with the simulation results. The model is flexible with the option of adding more retrofit measures, more locations, and more building design features. The model application is summarized in (Figure 3-3).

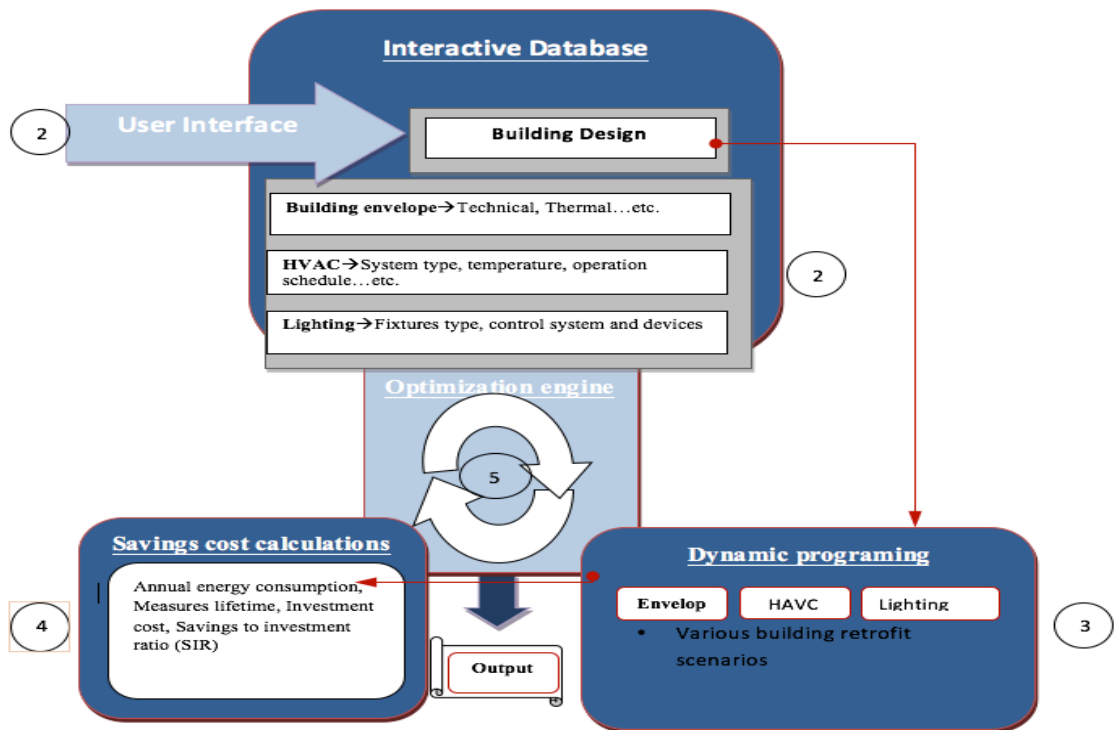

Figure (3-3) Summary of Model Application Framework

3.4.3 Dynamic programming approach

A building retrofit is a complicated problem from a calculation perspective due to the large number of variables affecting the decision. This is why dynamic programming helps facilitate the calculations for the ERDSS. This approach helps solve a complex problem by applying optimization to the building, by breaking the problem down into a number of simpler sub-problems, solving each of those sub-problems just once, and storing their solutions ideally, using a memory-based data structure through LabVIEW. The next time the same sub-problem occurs, instead of re-computing its solution, a model search engine simply looks up the previously computed solution, thereby saving computation time at the expense of a modest expenditure on storage space.

In order to achieve the goals of dynamic programming, the database information is divided into three sections, representing the three systems (building envelop, HVAC, lighting) that have the largest impact in building energy consumption, as recommended retrofit actions in AERG. It is essential to direct any given capital investment to the most cost-effective group of energy saving measures. In order to achieve this, the measures must be ranked according to a savings-to-investment ratio (SIR).

The interactive database has two main groups, as shown in Figure (3-4). “Group 1” is retrofit technical related information, including a list of retrofit measures and their associated technical data, building location, orientation and weather data which are extracted from the simulation output. “Group 2” has cost related information, such as retrofit initial costs, energy unit price, and inflation rate. Some “Group 2” data are derived from the cost database, while other cost data are user-input generated. Figure (3-5) show LabView model tree structure.

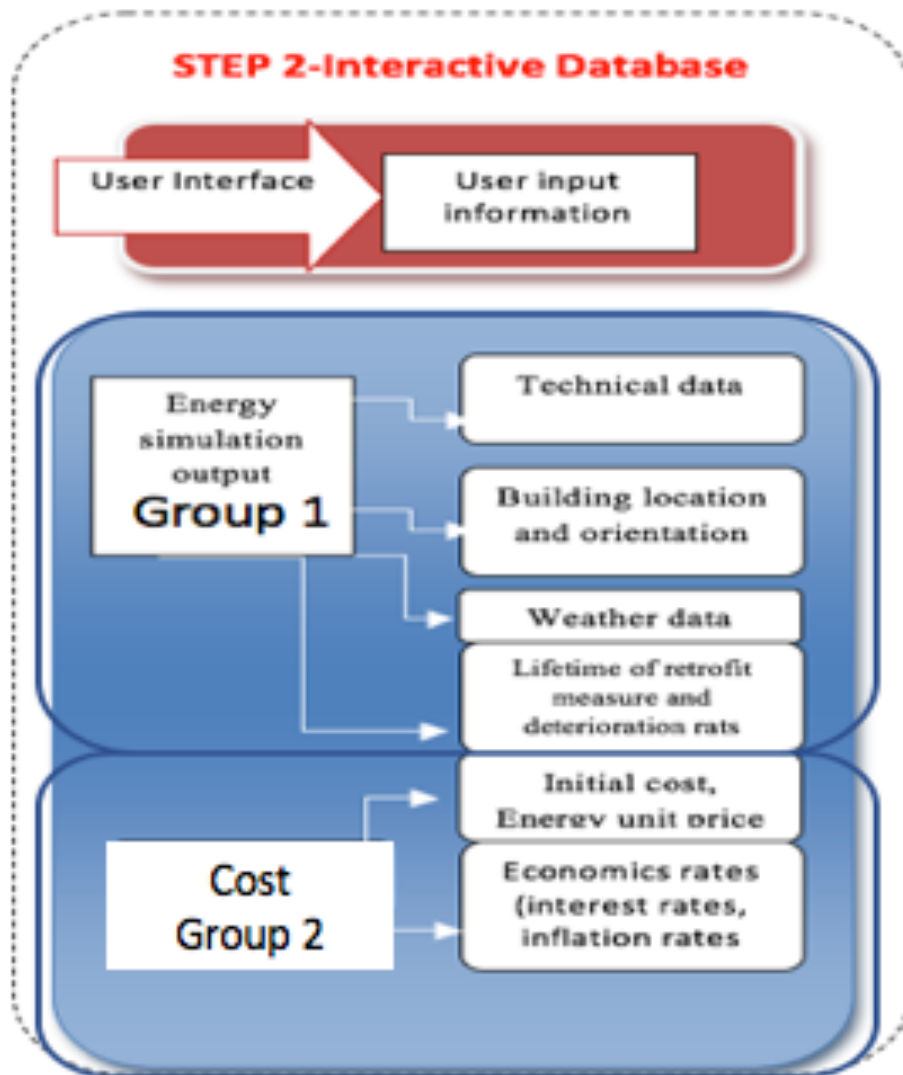

Figure (3-4): Database Main Components

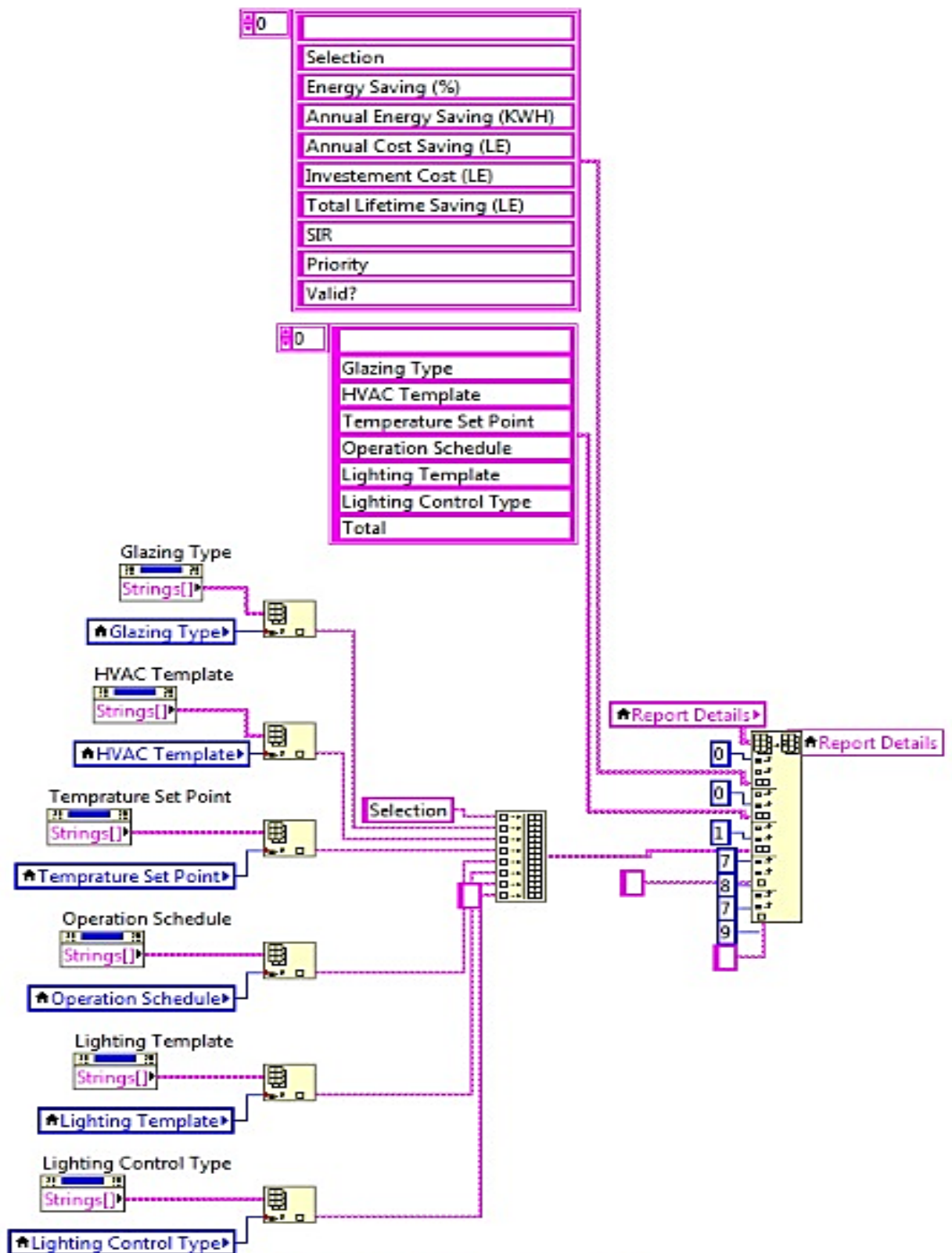

Figure (3-5): LabVIEW Model tree structure

3.4.4 Model interface

As mentioned previously, LabVIEW depends on a graphical interface; it allows the user to build a model using the libraries of active objects from a drop-down menu. The interface (Figure 3-6) consists of a number of views as follows:

- The first main screen contains building information: the building's name, the total building area in meters, the building total annual energy consumption in kWh, the energy unit rate in Egyptian pounds, the inflation rate ratio, and the retrofit allocated budget.
- The first sub-screen is the building envelope. The user selects design preferences for building envelope materials, such as the windows glazing type (single, double, triple glazing; double with glass film; and double with shading).
- The second sub-screen is the HVAC screen that reflects air-conditioning operating system with the selection of temperatures required to establish thermal comfort in summer and winter (Celsius). In addition, users select the building operation hours.
- The third sub-screen allows for the selection of building lighting and lighting control type.

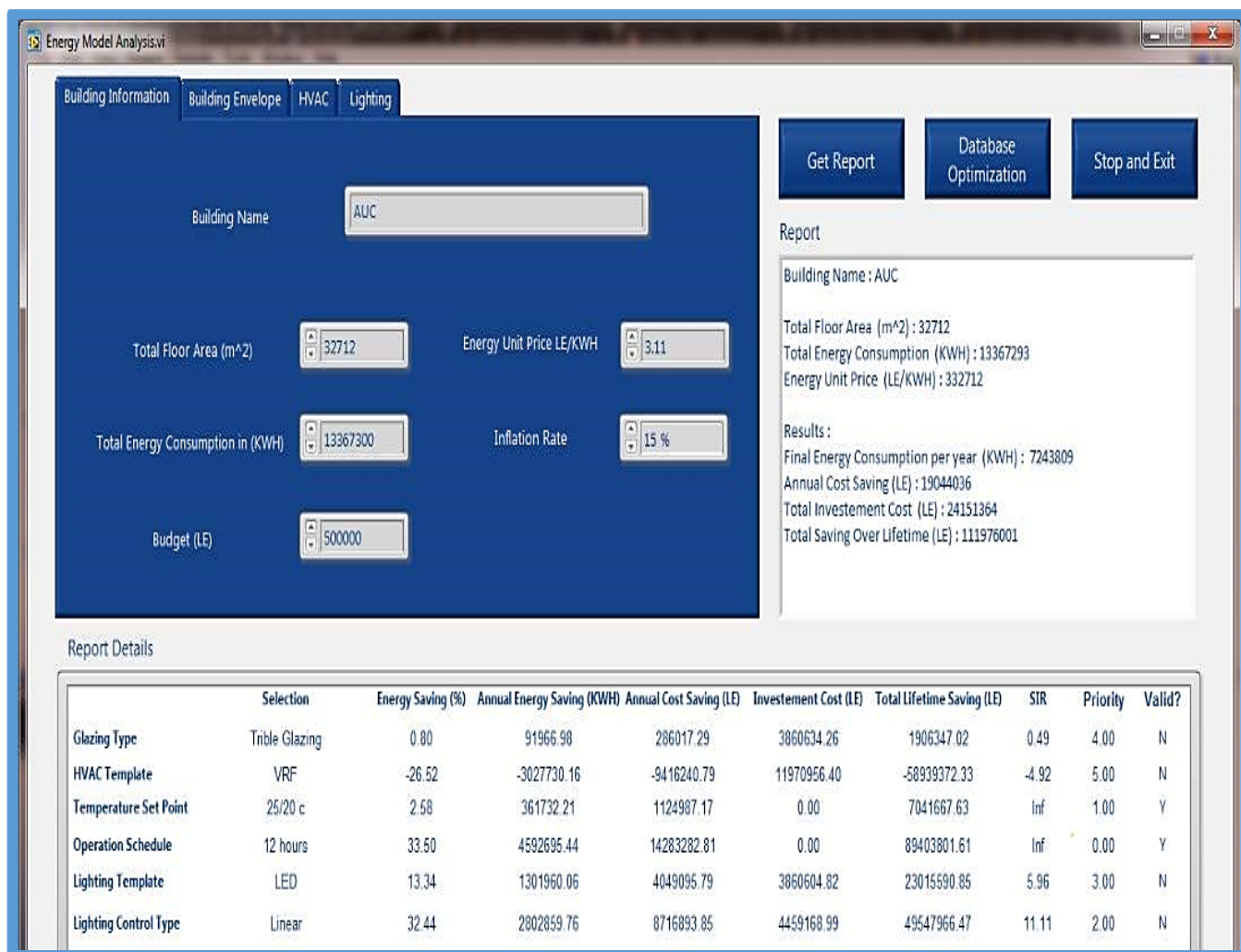

Figure (3-6): Building Information Screen ERDSS

3.4.5 Savings-To-Investment Ratio

The measure of performance that expresses the ratio of savings to costs is used for establishing priorities among different alternative. The numerator of the ratio contains the operation-related savings; the denominator contains the increase in investment-related costs. In order to calculate the SIR, first the model finds the total present value of energy saved quantity. A present value approach allows cash flow calculations over the retrofit life span, while considering the cost-equivalent value relative to current prices, in order to adjust future expected savings to their equivalent present value. Each section is calculated

individually. The impact (i.e. weight) of each retrofit measure is selected by the user. Then, it is converted into an annual value of energy saved after applying the simulation factor of error, using the energy unit cost (user input) and the measured lifetime in years (excel database calculation data).

$$\mathbf{PVC} = \mathbf{C} \left[\frac{1 - (1+r)^{-Lx}}{r} \right] \quad \text{Eq. 3-10}$$

Where, **PVc**: Present value

r: inflation rate (user input)

C: Expected annual cost saving LE

Lx: Lifetime of measure (in years)

Then, the expected annual saving kWh, **S_x**, is calculated using equation (3-1) and the expected annual savings in EGP is calculated using equation (3-11)

$$\mathbf{C} = \mathbf{Sx} * \mathbf{Er} \quad \text{Eq. 3-11}$$

Where, **C**: Expected annual saving cost LE

Er: Energy unit rate (user input) LE/kWh

The next step is to calculate the savings-to-investment ratio, **SIR**

$$\mathbf{SIR} = \frac{\mathbf{Pvc}}{\mathbf{Ix}} \quad \text{Eq. (3-12)}$$

Where, **PVc**: Present value of the total lifetime energy saving

Ix: Investment cost for retrofit measure LE

The model depends on calculating the expecting savings results from applying the retrofit measure and the expected savings per meter square (m²), in order to be able to conduct the calculations for different spaces within the same building parameters.

It is worth noting that there are some operational measures with no investment cost. This can include an adjustment in the operation method or of the hours using the BMS. The

model is designed to prioritize such activities first, because they will be of no cost to the investor but will nevertheless achieve savings. Therefore, the model prioritizes presenting these measures first, then moves on to calculate the measures that incur investment costs as shown in Figure (3-7).

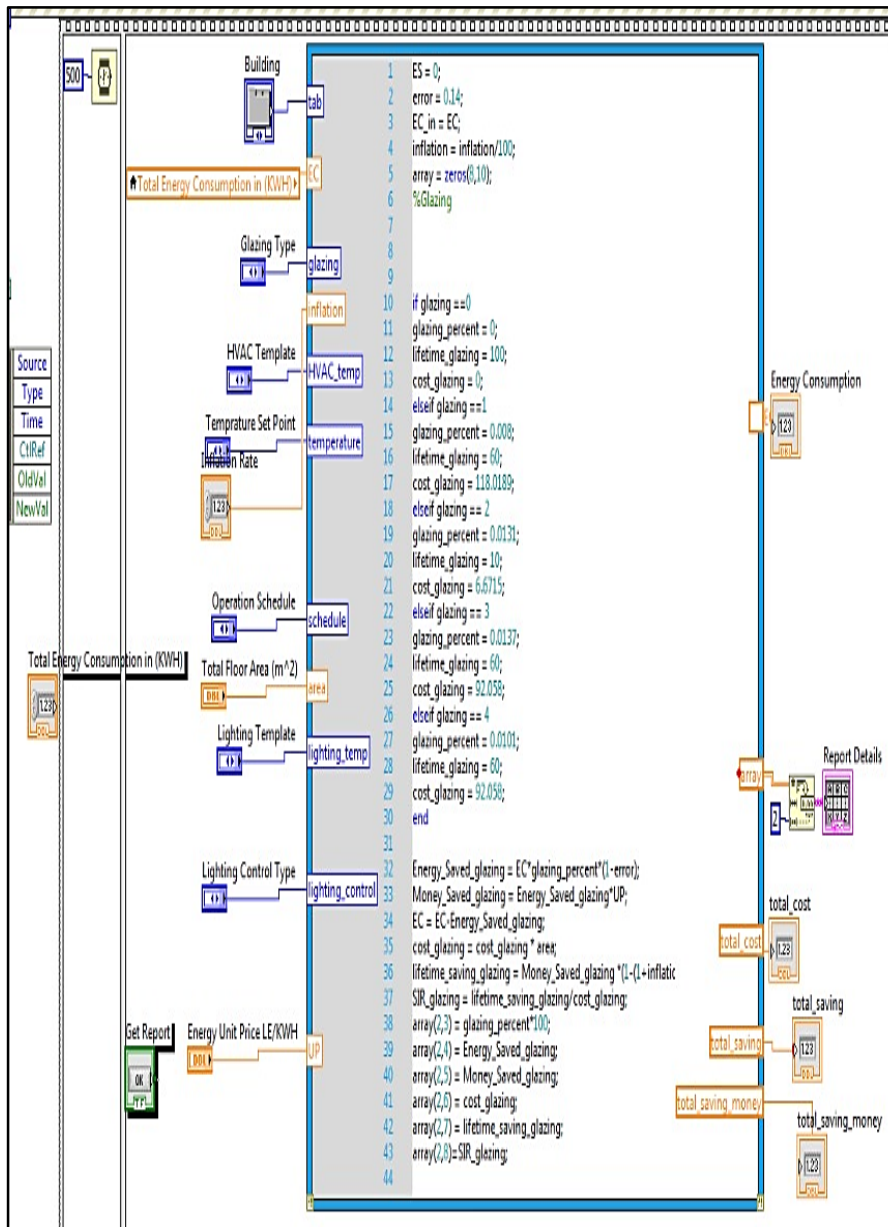

Figure (3-7) ERDSS Interactive Database savings calculation section (LabVIEW)

3.4.6 Optimization process and outputs

Developing an optimal retrofit scenario for an existing building requires the implementation of the most energy-effective measures within the allocated budget to select the most effective measures. It also requires the consideration of the intersection between the selected retrofits measures. Therefore, the selected list of measures should be implemented where the most cost-effective measure is listed first, in order to achieve the maximum return on investment.

The optimum scenario is formulated through an optimization problem. The variables represent the different retrofit alternatives of different building systems. The objective function is to minimize the energy consumption. The model constraint is the initial budget. The model uses LabView optimization engine (package add-Ins). The first level is the building 3 main systems; the first level is designed to perform model calculations that depend on the previously developed database (Figure 3-8). The second level includes each system sub classification of system categories from one to the number of alternatives selected by user, the second level is performing a project analysis according to the user retrofit measure selections and the cost calculation module. The third level includes the unique name of component in each system in integers and range from one to the number of systems alternatives entered by the user. It also involves using the multiple-retrofit-scenarios generator under the building information frame and within budget limitations.

The engine optimizes the selected measures to prioritize them according to the SIR priority of the selected measures to achieve the maximum return-on-investment for the selected scenario within the budget constraints. An optimization report that shows user-selected measures and their calculations (expected annual energy savings, annual savings

cost, investment cost, total lifetime savings, SIR ratio priority and conformity with the given budget) will also be generated (Figure 3-9).

The other feature that ERDSS can help decision-makers is the data assessment phase. As the retrofit-scenarios generator performs a general assessment for building information and budget limitations, the optimization engine filters the database information, through LabVIEW to generate a summary list of possible retrofit scenarios. The list of scenarios provides the decision-maker with a wider array of possible options for retrofit. The user selects scenario and previews the option details in the sub-screen (Figure 3-10). This provides the decision maker with optimum scenario for retrofit within the allocated budget. The optimization report for the selected scenarios illustrates each measure's calculation data and prioritizes them according to the SIR.

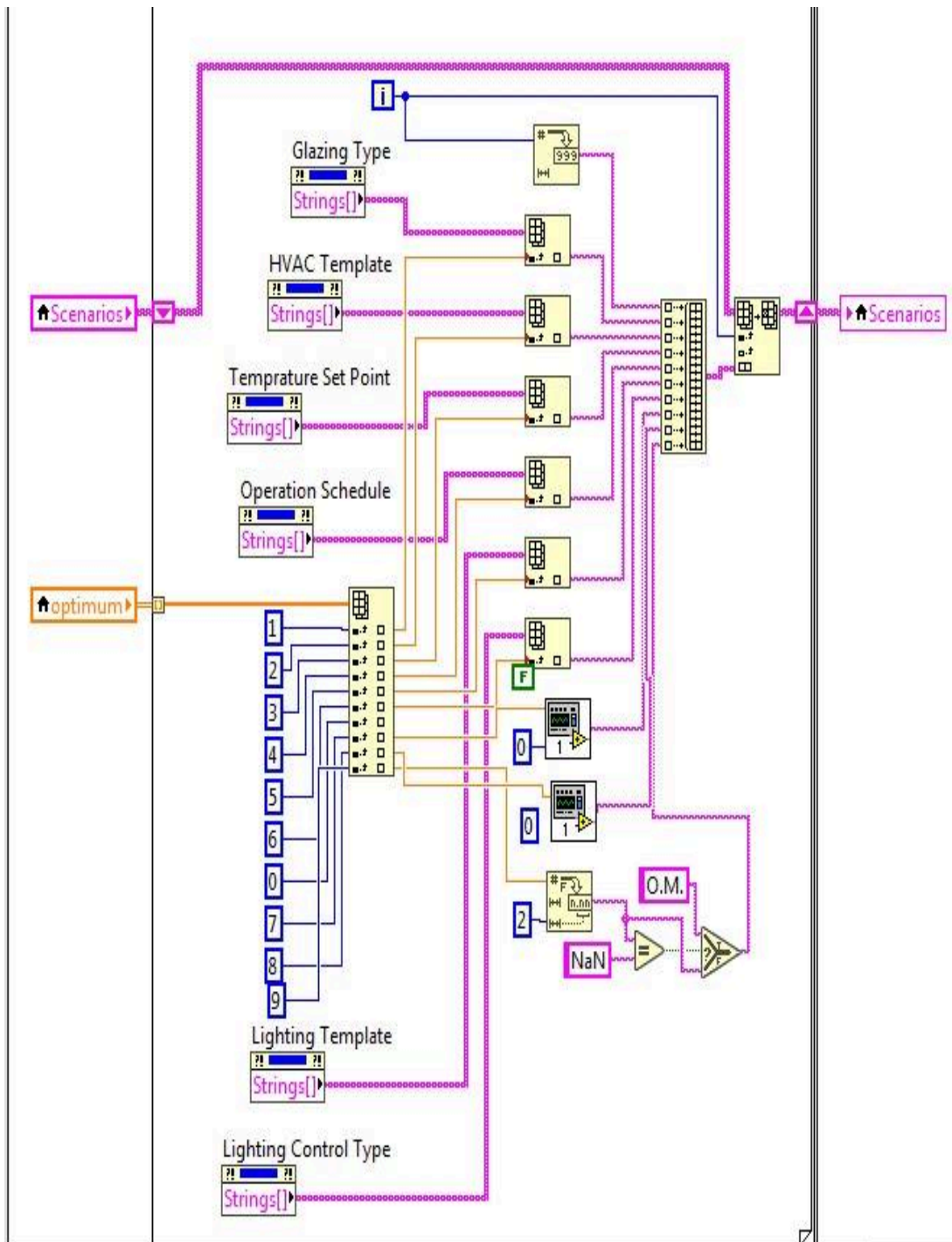

Figure (3-8) ERDSS Optimization engine (LabVIEW)

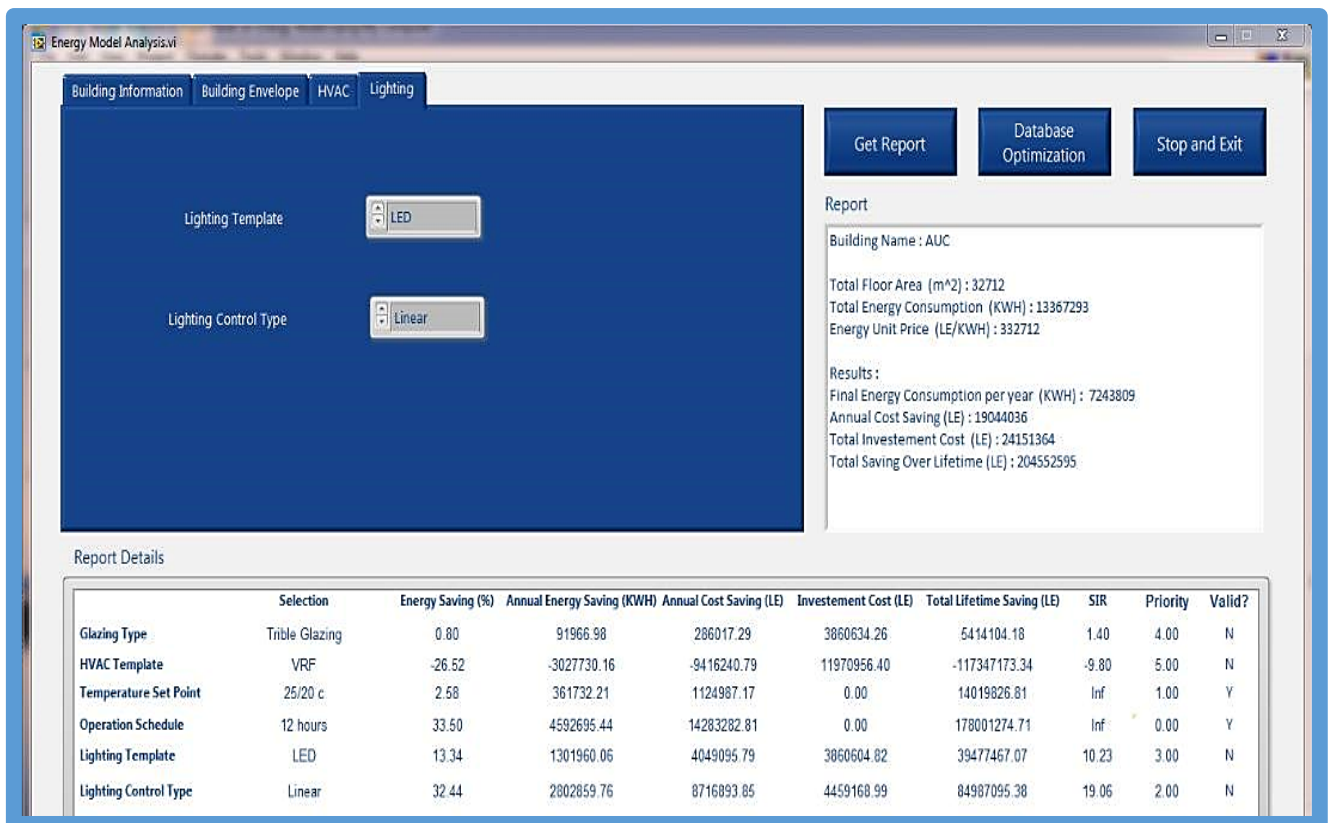

Figure (3-9) ERDSS Project optimization report (user interface)

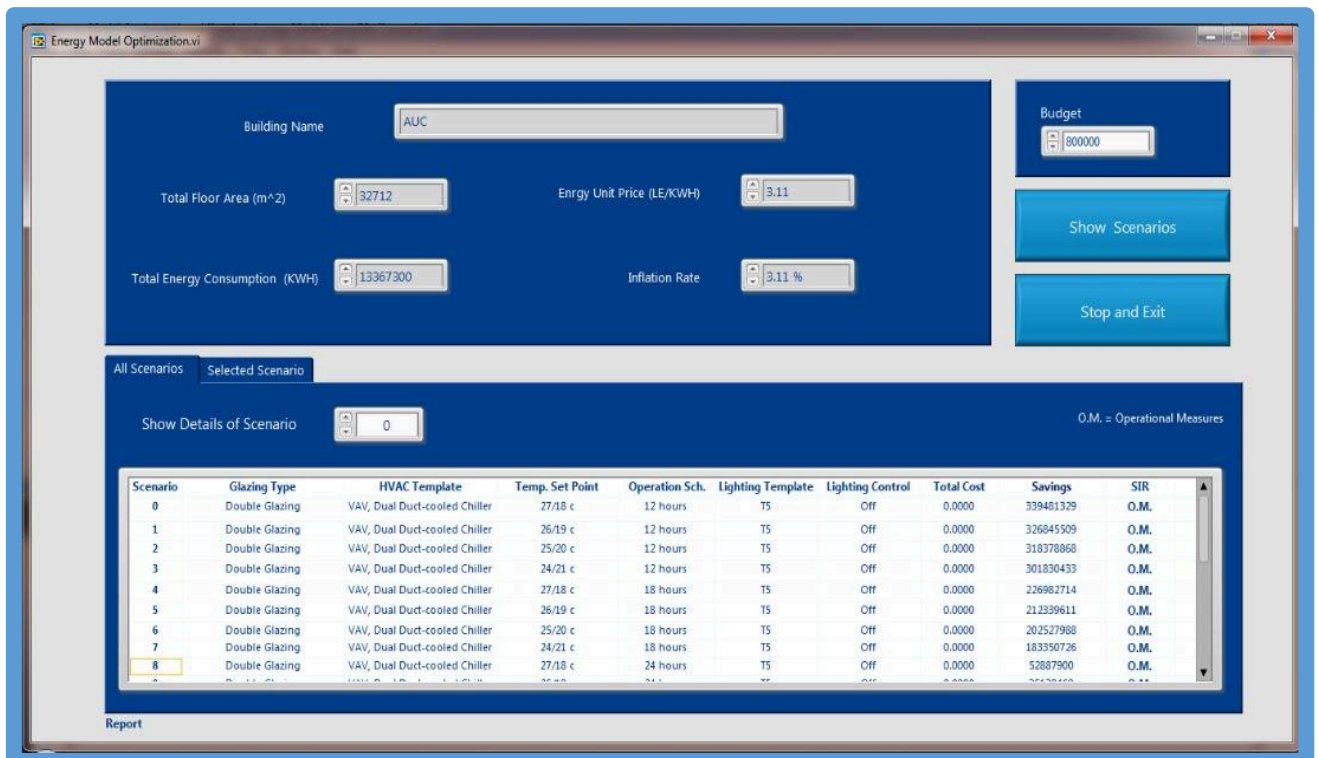

Figure (3-10) ERDSS Retrofit scenarios generator (user interface)

ERDSS provides the decision-maker with a clear guide for retrofit selection with its SIR. This facilitates selection of the optimum retrofit scenario. At the same time, the model provides a clear vision for future possible retrofit options depending on the budget availability with their expected initial investment cost and SIR, which are considered within an organizational budget plan matrix. Also, it provides the decision-maker with a future retrofit plan for other comparable campus buildings.

3.5 Conclusion

This chapter presented the proposed technique/framework and the simulation methodology used in developing an Energy Retrofit Decision Support Model (ERDSS). ERDSS was developed using LabVIEW software. The model development process can be summarized into six steps:

- Dynamic programming
- User interface development
- Interactive database development
- Savings calculation analysis
- Optimization engine

A simulation baseline scenario is applied and compared to actual readings for a building to identify the simulation factor of error. The model core optimization engine is developed using LabVIEW. ERDSS works through savings calculations for the selected retrofit scenario within the budget limitations, and the optimization engine generates multiple retrofit options and recommends the optimum scenario.

The next chapter will discuss a case study application using the ERDSS model. Case study results will be discussed and incorporated into comparative analyses, simulation, and sensitivity analysis.

CHAPTER 4:

Model Implementation and Validation

CHAPTER 4: Model Implementation and Validation

4. Introduction:

In the previous chapter, the framework for developing a simulation and optimization model for retrofit application on a university building is outlined. This chapter discusses the implementation of ERDSS on an existing campus building as a case study. Figure (1-4) shows the different steps followed for model implementation that include:

1. Construction of building simulation model
2. Database library development
3. Applying ERDSS optimization
4. Decision making

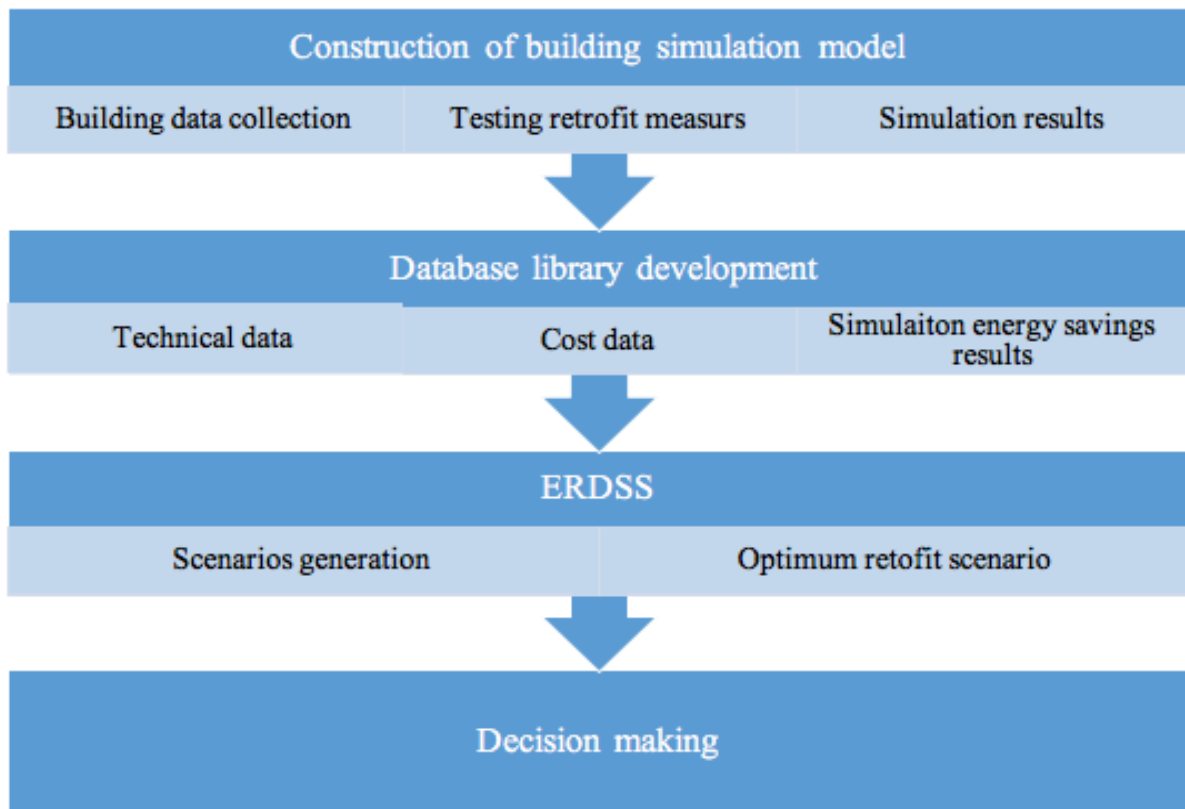

Figure (4-1) Model framework

4.1. Case Study

The building selected for the case study is an educational building in New Cairo, The School of Sciences and Engineering Building (SSE), located in the campus building of the American University in Cairo (AUC), Egypt.

SSE is building's area is 32,000 m² and has four floors (Plaza, first, second and roof). The plaza level contains classrooms, labs and workshops. A plan for the first floor is shown in figure (4-2) that contains labs and administrative offices. The building is divided into four mechanical zones served by 21 Air handling Units. Each zone contains spaces with identical functions and HVAC zoning. The building envelope is a double wall (will be discussed in detail in the forthcoming simulation input section). Glass comprises approximately 30% of the overall façade. All windows are erected on wooden frames and include double-glazing. The current HVAC operation system is Variable Air Volume (VAV) and most of the light fixtures are fluorescent T5.



Figure (4-2) SSE First floor Plan

4.1.1 Assessing building energy performance for diagnosis analysis

The diagnosis analysis process for educational building green-energy retrofit starts with setting a plan to collect all possible building data. It can be divided into the following phases:

- Data collection
- Pre-retrofit survey
- Energy Audit, Performance Assessment, and Diagnostics
- Identification of retrofit scenarios

4.1.2 Data collection

All available documents concerning the building construction and operations technical data, such as material specification and operating systems are collected. The quality and quantity of technical data collected depend on the available documentation from the project construction phase, such as drawings, material data sheets, architectural standards and specifications, air conditioning system and lighting system, type of operation system and operation schedule, temperature set point, lighting fixture catalogs, and current operational reports, such as BMS readings for building monthly and annual energy consumption. The data collected focused on four main categories as shown in (Table 4-1).

The table shows each zone name, function, occupancy rate for each space function, operation hours, % of openings and lighting fixtures types.

All the building collected information in this phase are the basis for the future retrofit database library development. Therefore, it is important to collect the most possible accurate data, as the quality of the data will impact the accuracy of results of all model outputs.

Table (4-1) Simulation input data categories

Building activity	Part A plaza L	Part A 1 st F	Part A 2 nd F	Part B plaza L	Part B 1 st F	Part B 2 nd F	Part C plaza L	Part C 1 st F	Part C 2 nd F	Part D plaza L	Part D 1 st F	Part D 2 nd F
Zone's function	Labs	Labs	Labs	Labs	Labs	Computer labs	Classrooms	Admin offices	Admin offices	Classrooms	Admin offices	Admin offices
Occupancy rates	9/student /m2	6/student /m2	5/student /m2	9/student /m2	2.8/student /m2	2.3/student /m2	3 m2/EFTS U	8-14 m2 office space/ Preson	8-14 m2 office space/ Person	3 m2/EFTS U	8-14 m2 office space/ Preson	8-14 m2 office space/ Preson
Operation hours (Baseline)	7:30-20:00/ Off Fr.	7:30-20:00/ Off Fr.	7:30-20:00/ Off Fr.	7:30-20:00/ Off Fr.	7:30-20:00/ Off Fr.	7:30-20:00/ Off Fr.	8:00-20:00/ Off Fr., Sa.	8:00-20:00/ Off Fr., Sa.	8:00-20:00/ Off Fr., Sa.	8:00-20:00/ Off Fr., Sa.	8:00-20:00/ Off Fr., Sa.	8:00-20:00/ Off Fr., Sa.
Walls typs	Wall 2 Stone finish	Wall 1 Drymix finish	Wall 1 Drymix finish	Wall 2 Stone finish	Wall 1 Drymix finish	Wall 1 Drymix finish	Wall 2 Stone finish	Wall 2 Stone finish	Wall 2 Stone finish	Wall 2 Stone finish	Wall 2 Stone finish	Wall 2 Stone finish
Openings	25% Vertical glazing	25% Vertical glazing	25% Vertical glazing	25% Vertical glazing	25% Vertical glazing	25% Vertical glazing	35% Vertical glazing	35% Vertical glazing	35% Vertical glazing	35% Vertical glazing	35% Vertical glazing	35% Vertical glazing
Lighting	T5 flurescent Luminous and louvered ceiling	T5 flurescent Luminous and louvered ceiling	T5 flurescent Luminous and louvered ceiling	T5 flurescent Luminous and louvered ceiling	T5 flurescent Luminous and louvered ceiling	T5 (16mm) flurescent Surface mount	T5 (16mm) flurescent Surface mount	T5 (16mm) flurescent Suspended	T5 flurescent Suspended	T5 (16mm) flurescent Surface mount	T5 (16mm) flurescent Suspended	T5 (16mm) flurescent Suspended

4.1.3 Pre-retrofit survey

The pre-retrofit survey starts by conducting interviews with the facilities and operation team, external consultants, and vendors in order to understand current building operation pattern, discusses the user’s requirements and operation team output regarding the different systems performance, identify the possible areas of improvements. This survey helped to define the problem of operation schedule, as most of spaces systems are fully operated all day even if it is not occupied.

4.1.4 Energy Audit, Performance Assessment, and Diagnostics

Energy audits play an essential role in the green retrofit process. It is used to identify areas with energy-saving potential through a breakdown structure analysis as shown in (Figure 4-3).

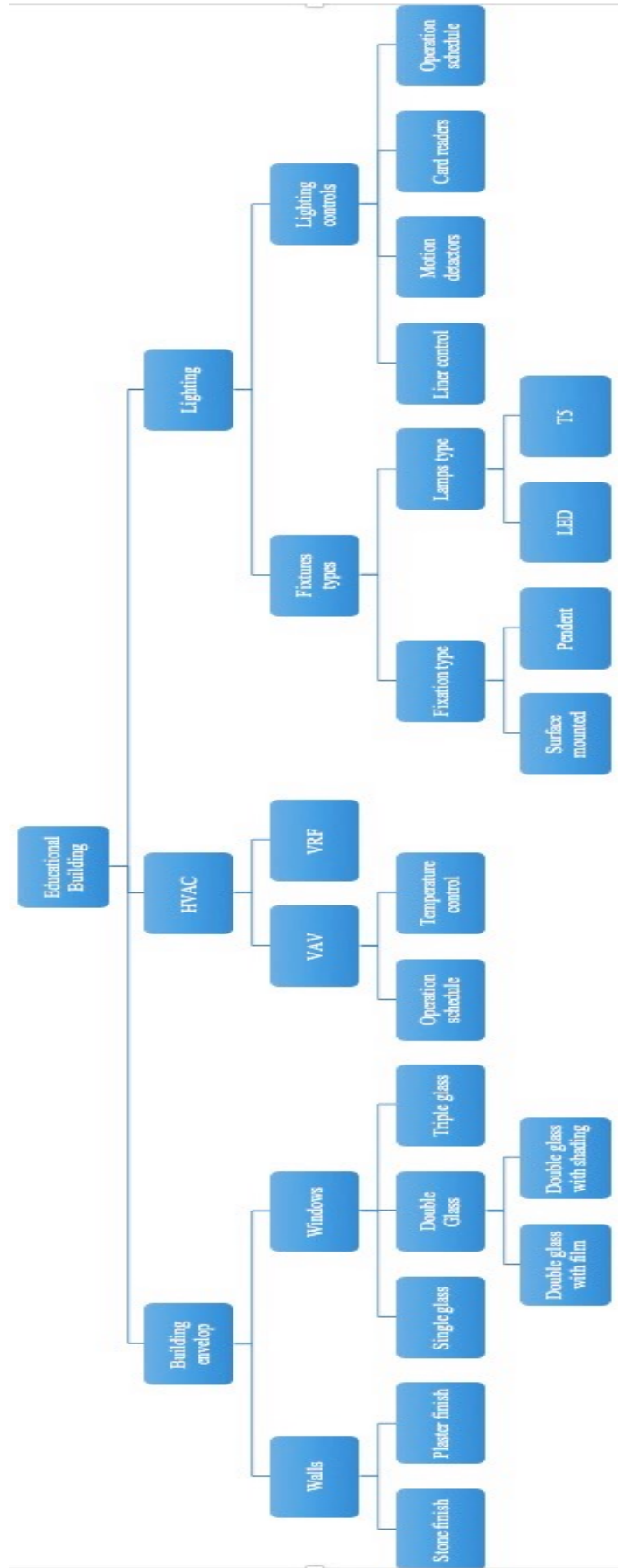

Figure (4-3) Model breakdown and structure

The first level of the diagram represents the main goal, which is to achieve the optimum retrofit. The second level represents the main criteria and objectives (building main systems: HVAC, lighting, building envelope). The next level deals with actual retrofit measures, such as energy consumption for each system, operation hours, and thermal comfort standards. The lowest level of the tree is an indicator of clear numerical factors for various system components, such as lighting systems, fixtures, lamps, automation systems, and motion detectors.

The energy audit is used to analyze SSE energy data, in order to understand the building's actual energy needs, and to identify areas of energy waste, which can cause cooling and heating leakage. Energy assessments were performed through collecting readings from BMS for the SSE building, site visits, review of the as-built drawings and technical specifications. Energy assessments for current operation were compared with systems original design documents (the benchmark for all HVAC systems materials specifications is ASHRAE standards).

4.1.5 Identification of retrofit scenarios

During the energy audit, it was determined that 55% of all electricity used in the building is for HVAC, 35% for lighting, and 10% for office equipment and other appliances. These results were based on shutdown tests conducted by the AUC facilities and operations team, which found that shutting down all major HVAC equipment (drives pumps, AHUs, VAV units, fans, and other HVAC equipment) during working hours reduces building electricity demand by approximately 55%. As for lighting and office equipment, the same process was applied. After identifying the potential areas of improvement, the retrofit targeted measures, can be enhanced are as follows:

4.1.5.1 Building envelope (walls-windows)

The walls are designed as double walls with 20 cm cement hollow blocks, 7 cm wall cavity, another 10-cm wall layer made of cement, and the final layer is stone as shown in (Figure 4-4). Design energy conductivity specifications for this system indicated efficiency for preventing temperature transfer.

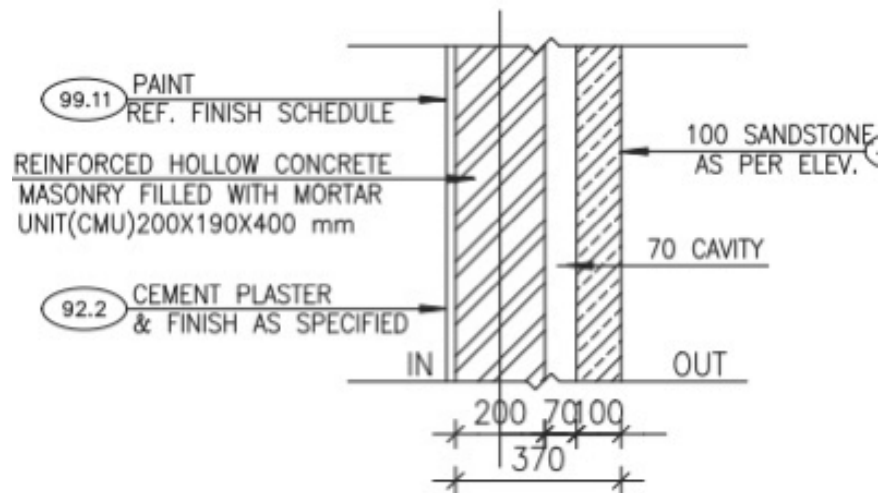

Figure (4-4) SSE Wall section

According to building design data the SSE external walls are designed to cope with architectural, construction, and environmental needs, with an average U-value as follows:

1. External Walls (all orientation): 0.56 W/m^2 .
2. Roofing Systems: 0.42 W/m^2 .

The window system for the four facades includes wooden window frames, with clear double glass and an air layer with rubber seals to prevent sound and dust. The glass percentage is 30 % average of the total facade area (Figure 4-5).

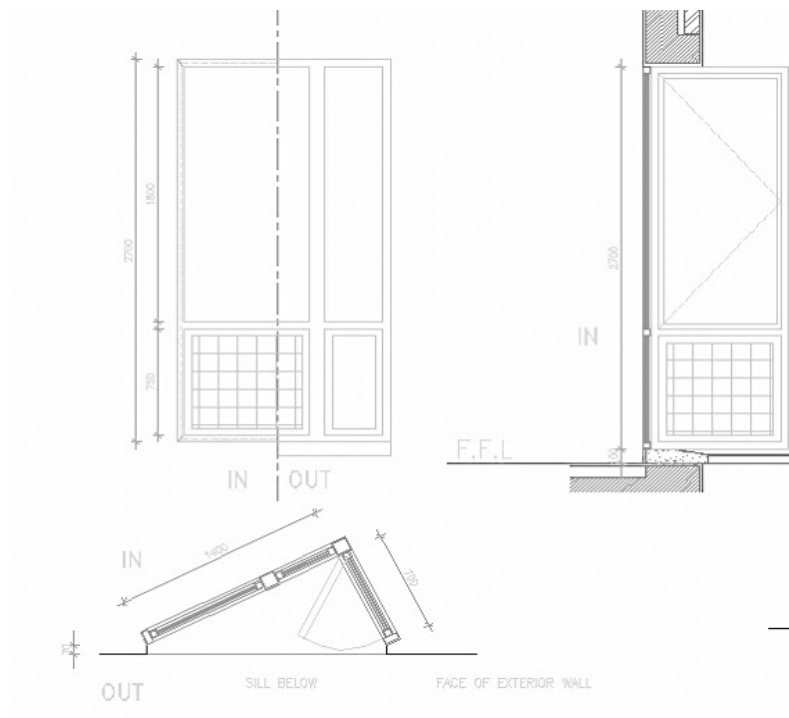

Figure (4-5) SSE window type sample

4.1.5.2 HVAC System retrofit data

According to energy audit results and BMS reports, the HVAC is the largest energy consumption system, and the retrofit measures for HVAC as resulted from simulation will result in electricity savings and improved carbon efficiency for campus electricity usage.

1) HVAC operation hours (operational measure)

HVAC operation hours are currently scheduled from 6 am until 1 am. The operation retrofit measure is to set the BMS to a new operational schedule, to be adjusted according to each building zone's actual operation hours.

2) AC temperature adjustment (operational measure)

Thermostat settings should be adjusted to meet the minimum range of thermal comfort depending on the season, which include raising or lowering the temperature setting (in some cases by nearly 3° C) to eliminate over-cooling and over-heating.

3) Changing HVAC to Variable Refrigerant Flow (VRF) deep retrofit measure

The building evaluation study conducted by mechanical consultant recommends replacing the existing HVAC system with a VRF system to avoid the cost of energy used for both utility plant and HVAC equipment. A long-term plan depends on the assessment of the system updates and adding new technologies to the HVAC systems. Alternative options involve renewable energy, and cost estimation. A payback period analysis should be performed to compare savings.

4.1.5.3 Lighting system retrofit actions

1) Change lamps to LED (standard retrofit measure)

Lamps to be changed to LED because LED uses less energy and have longer lifetimes as shown in (Table 4-2).

Table (4-2) Sample of LED lighting cost analysis for SSE

LED Type	Replace	Lumine	Color	Socket	Quantity	Unit Price	Total Price	Payback period
PAR 38 24 W	75 Halogeen	2200	Warm ,white	E 27	150	400	60.000	1.1 Year
PAR 38 24 W	70 M Halid	2200	Warm ,white	E 27	200	400	80.000	1.2 Year
PAR 38 15 W	35 M Halid	1400	Warm ,white	E 27	100	300	30.000	1.3 Year
PL- 10 Watt	26 watt	1000	Warm ,white	2 benz	350	90	31.500	1.8 Year
TS LED tube 7 Watt	13 watt T2	600	Warm ,white	NA	350	70	24.500	1.8 Year

2) Lighting control systems (standard measure)

The proposed retrofit lighting control measures are to add timers to control landscape lighting hours in order to adjust their operation schedule to start gradually after sunset. Motion detectors should be used for classrooms and card readers for offices. The calculated payback period considered the increase of the electricity rates and the current operation plan.

4.2 Building energy simulation

Building energy simulation for SSE building is conducted with Designbuilder software tool to predict building energy consumption after applying each retrofit measure. Both modeling and simulation phases are accounted for all building data sources. The operation of the HVAC, lighting system, and energy consumption of the whole building are studied in detail to assess building energy performance. Also, factors that affect thermal comfort of the occupants during summer and winter are identified. Furthermore, the whole-building annual thermal performance studies are performed in order to evaluate and facilitate retrofit decision-making.

As discussed in chapter 3, a computer model (EDRSS) for prediction of an optimum retrofit has been developed. Model database uses simulation output data through optimization engine to help decision makers to select the optimum retrofit scenario for building energy consumption within the budget limitations. Building occupant thermal comfort is identified through energy audit performed by building operation team, taking into account the factors that affect building energy utilization on an hourly, daily, monthly and yearly basis in addition to considering weather information, building geometry, and utility rates. The selected simulation tool is equipped with data templates for a variety of building simulation inputs, such as typical envelope construction assemblies, lighting systems, and editable occupancy schedules.

The building's simulation geometric model is shown in figure (4-6). The simulation depends on assessing internal load schedules based on a detailed building materials survey, including monthly metered data for heating, lighting, and cooling over a one-year period. The purpose of the simulation is to evaluate the potential for improvement of retrofit

measures on building energy consumption, in order to quantify the weight of each retrofit action.

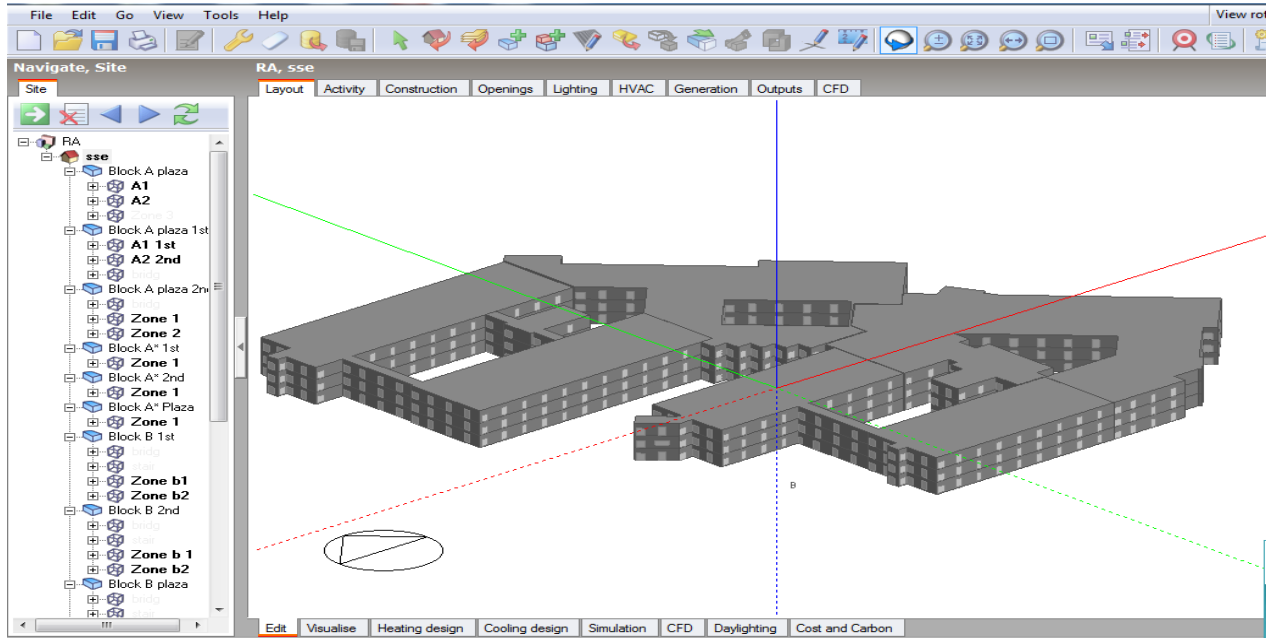

Figure (4-6) SSE building’s model in simulation tool

4.2.1 Building energy simulation baseline

The first step in using the simulation tool is to select the building location, the next step is to create building blocks in layout view. SSE is divided into 4 main zones (Table 4-3), and each zone consists of 3 blocks (Figure 4-7) with total number of 12 sub-zones. The blocks are divided according to the building HVAC system zoning, which are configured based on specific activities and functions.

Table (4-3) Buildings’ zones in simulation

Floors/ Zones	Zone A	Zone B	Zone C	Zone D
Plaza Floor	Labs	Labs	Classrooms	Classrooms
First Floor	Labs	Labs	Admin. Offices	Admin. Offices
Second Floor	Labs	Computer Labs	Admin. Offices	Admin. Offices

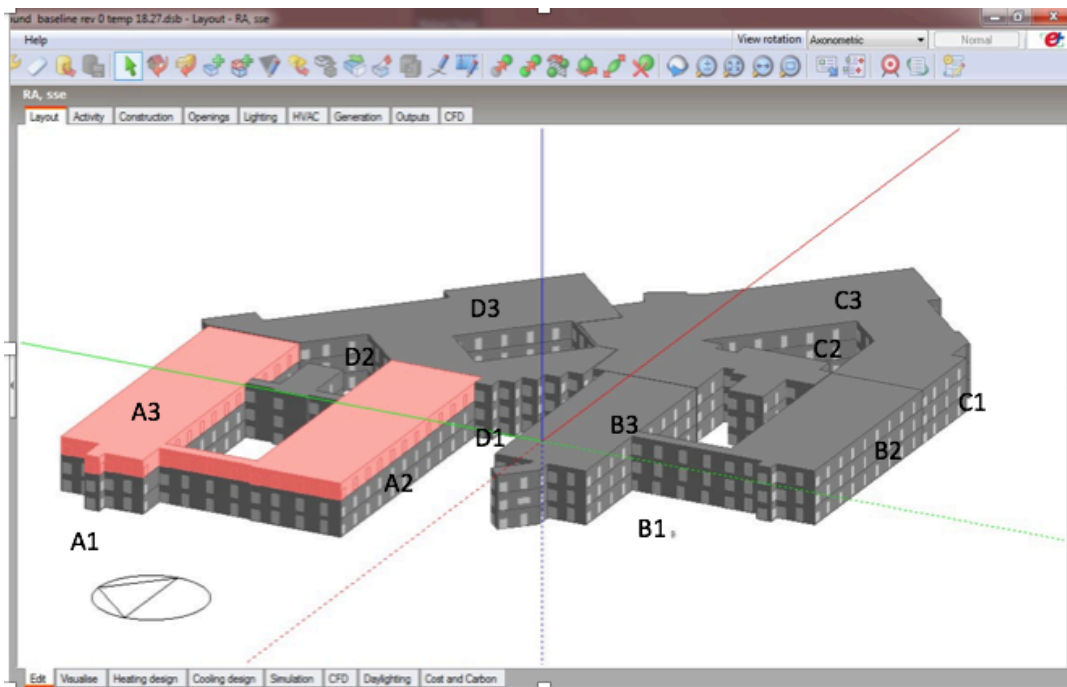

Figure (4-7) SSE simulation zoning

The simulation model of building baseline is developed using accurate physical characteristics collected during the on-site building investigation. The building envelope characteristics are gathered from the available architectural drawings and audit reports on building structure and facade. The mechanical system, lighting, equipment, occupancy, and operational profiles are collected with the assistance of building operation and maintenance personnel.

4.2.2 Simulation scenarios

Through simulation process, the building blocks are used as modules, each block needed different set of data inputs for this space type, which include:

- Functions and activities operation patterns (operation schedule, temperature set point, occupancy rates)
- Construction materials (walls layers, insulation type, roof system)
- Openings (glazing percentage, glass layers, window frame, doors)

- Lighting (type of fixture, lighting control and dimming features)
- HVAC (system type, summer and winter temperature set points, natural ventilation)

The hourly, weekly, and monthly whole-building energy simulation of SSE was performed using international weather calculations data (EnergyPlus, 2010), for a full year of operation prediction. In order to validate simulation results hourly, weekly, and monthly electricity consumption predictions are compared with BMS and utility bill data. Several model calibrations were performed by reviewing operational profiles, zone set point temperatures, infiltration rates for summer and winter periods. The acceptable tolerance for monthly and annual data is defined using the ASHRAE Guideline 14 (ASHRAE, 2002).

The predicted energy end-use is performed to establish the retrofit measures list with associated energy savings. Therefore, it is important in building energy retrofit measures plan to optimize the building performance for subsequent retrofit energy savings.

The actual energy readings are compared with the simulation output for the same operational measures to identify the factor of error to be considered for other simulation outputs. Most of the performed tests were done in the summer vacation period or on weekends, in order not to disturb the classes. The tests are conducted with the help of an in-house team of technicians and engineers.

The simulation model results factor of error is compared with actual overall annual energy consumption, and a factor of error of 14% is found, as shown in Table (4-4).

Table (4-4) Simulation baseline data versus BMS actual readings kWh

Baseline Summary			
Baseline	Week Days	Week End	
SSE Labs (Baseline)	7.30 :20.00	Off/ Friday	
SSE Offices (Baseline)	8.00 :20.00	Off/ Friday , Saturday	
SSE Classes (Baseline)	7.30 :20.00	Off/ Friday , Saturday	
Temperature set point	Baseline		
Cooling Set point	24		
Heating Set point	21		
Baseline year	Actual Annual Readings	Simulation Annual Readings to meet design	Factor of error
Over All 2012	13,367,293.00	15,498,607.03	14%

4.3 Developing building retrofit measures database

A database is developed to combine each simulation results. In order to identify the impact of using each retrofit measure individually, all the other simulation modules are set fixed (to be similar to the data in the baseline), and only the retrofit measure new input data is modified. This process is performed while taking into consideration the calculated factor of error, and the measure weight percentage to the overall building systems as follows:

4.3.1 Temperature control scenarios

- Temperature control Option (1), changing temperature set point to be more / less (summer /winter) by 1°C: The simulation projected around 2.5% savings from the annual energy consumption.
- Temperature control Option (2), changing temperature set point to be more / less (summer /winter) by 2°C: Simulation resulted in around 4.5% savings from the annual energy consumption.

- Temperature control Option (3), changing temperature set point to be more / less (summer /winter) by **3°C**: Simulation resulted in around **6.8%** savings from the annual energy consumption, as shown in figure (4-8).

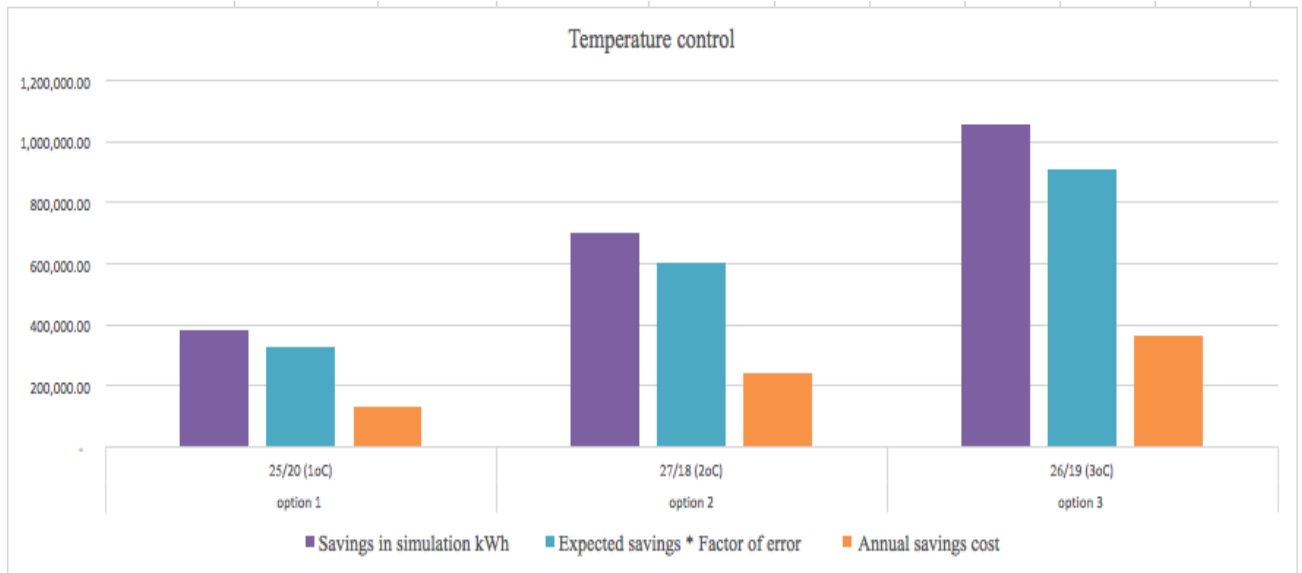

Figure (4-8) Simulation temperature control output

4.3.2 Operation schedule scenarios

- Operation schedule control (option 1), changing current operation hours with customized operation schedules: Simulation resulted in **20.3%** savings from the annual energy consumption.
- Operation schedule control (option 2), BMS programmed on weekly updated 3 different operation schedules to match 3 different building timetables that depends on space function (Labs- classes – offices): simulation resulted in approximately **30.3%** savings from the annual energy consumption, as shown in Figure (4-9). Changing operation hours achieved a high percentage of savings as it includes savings for both HVAC and lighting systems.

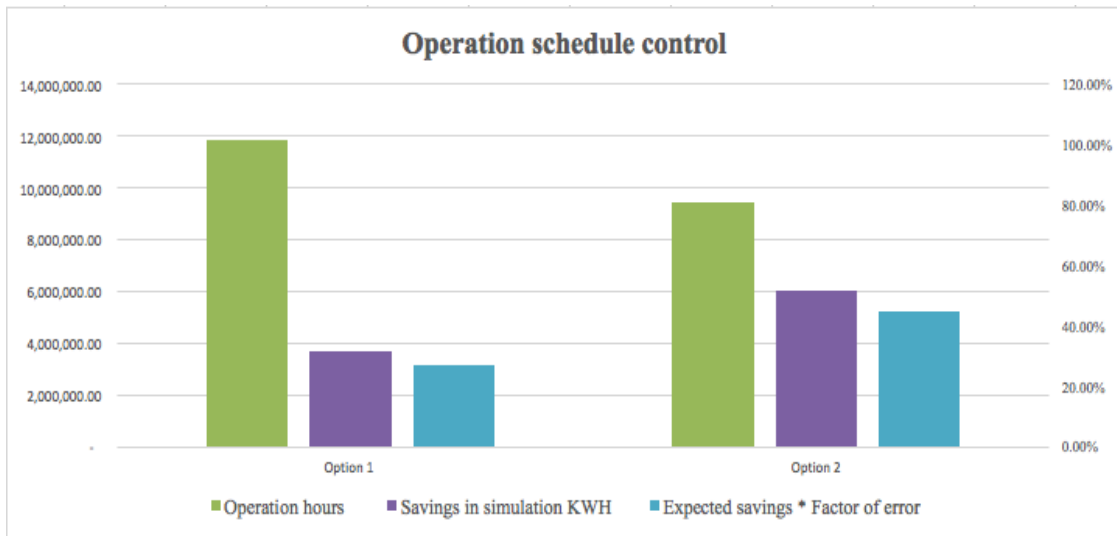

Figure (4-9) Simulation operation schedule control output

4.3.3 LED Lighting fixtures and lighting liner control

- Option 1, changing the current lighting lamps with LED lamps (with a longer lifetime, better efficiency, and less energy consumption): Simulation resulted in a **13.3%** savings from the annual energy consumption, as shown in Figure (4-10).
- Option 2, changing the current lighting lamps to LED lamps and adding automation linear controls to manage the operation based upon schedule or demand. After using LED and customizing the operation timing: simulation resulted in around **23%** savings from the annual energy consumption.

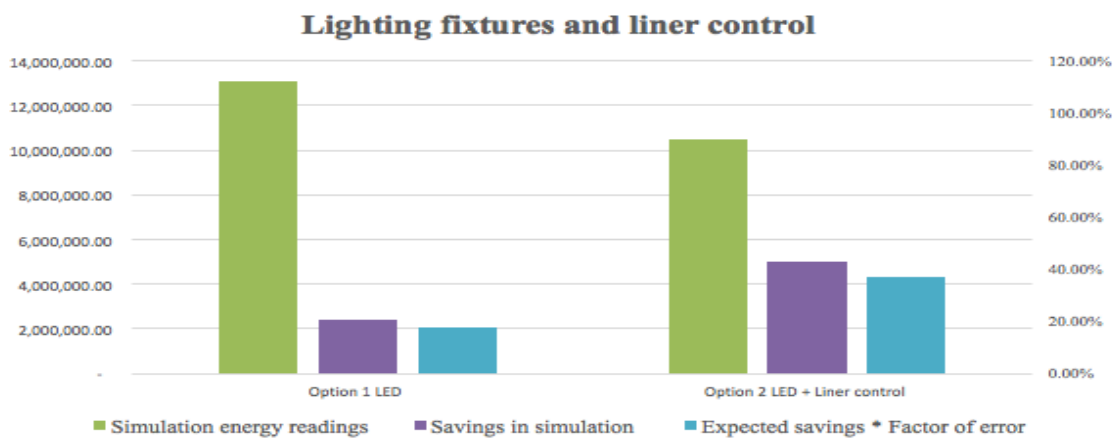

Figure (4-10) Simulation output for adding LED lighting fixtures and lighting liner control

4.3.4 Windows glass and shading options

- Option 1, changing windows double-glazing with triple glazing of 6 mm air cavity: simulation resulted in around **0.1 %** savings from the annual energy consumption.
- Option 2, changing the current double-glaze windows with a single glass design: simulation resulted in around **0.1%** increase in cost of the annual energy consumption.
- Option 3, adding film to the current window systems that have double-glazing: simulation resulted in around **1.3 %** savings from the annual energy consumption.
- Option 4, adding wooden shading to the current window systems (double-glazing): simulation resulted in around **1.4 %** savings from the annual energy consumption, as shown in Figure (4-11).

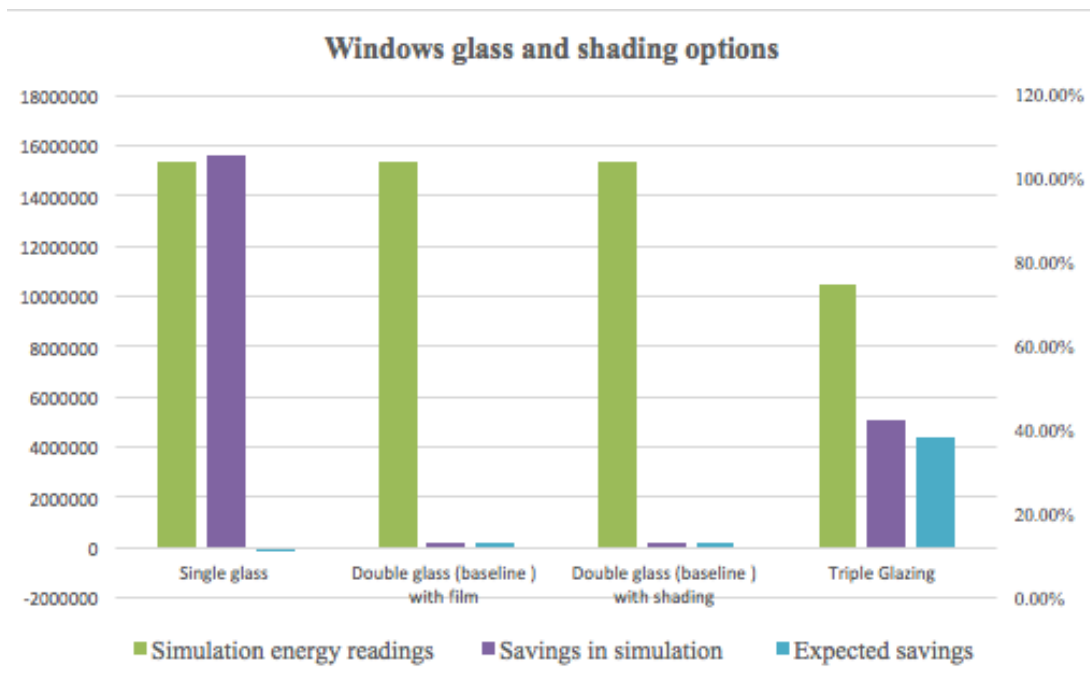

Figure (4-11) Simulation Windows glass and shading options output

4.3.5 HVAC system change

3) Changing HVAC system to VRF: Simulation resulted in 26 % increase in cost from the annual energy consumption, as shown in Figure (4-12).

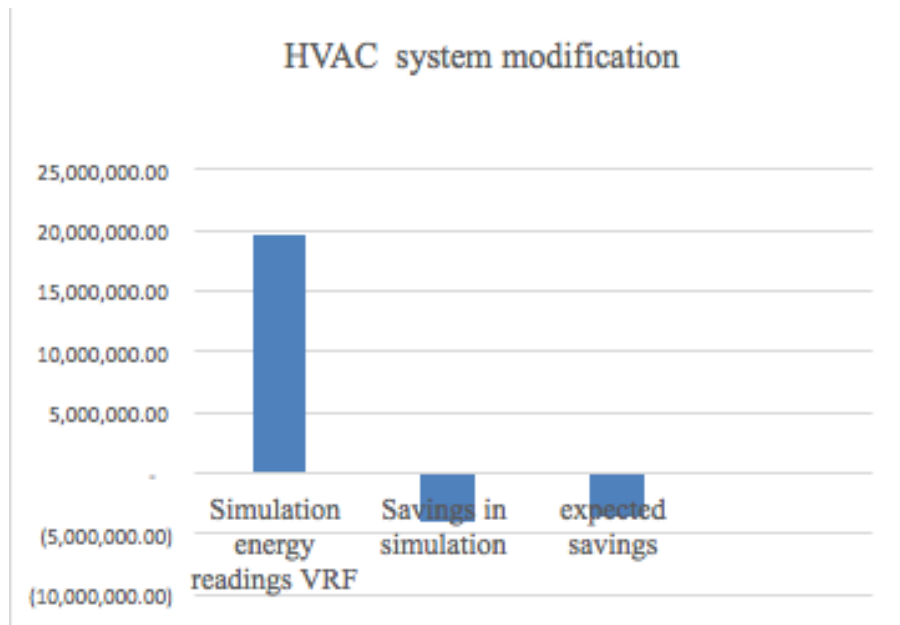

Figure (4-12) HVAC System modification

4.3.6 Cost analysis

The selection of retrofit measures is a tradeoff between capital investments and future benefits from the green retrofit implementation. Economic analysis facilitates the comparison between alternative retrofit measures, as it provides a clear indication of whether the retrofit alternatives are both energy- and cost- efficient.

The previous retrofit actions are investigated individually while considering each measure initial costs, expected savings, benefits, the inflation rate, and lifetime. After that, all simulation output reports, analyses and collected data are combined within the database library structure. Also, an initial cost for each measure is collected from certified vendors to get the market price, in order to provide all the needed information for the ERDSS database to select the optimum retrofit measure within the allocated budget. This happens to facilitate

the model selection for the optimum cost-effective group of energy savings measures. As illustrated in the previous chapter, the proposed measures are ranked in decreasing order of Saving-to-Investment-Ratio (SIR), which reflects the economic performance of an investment.

$$\text{SIR} = \frac{\text{PVC}}{\text{Ix}}$$

PVc: Present value of the total lifetime energy saving

Ix: Investment cost for measure

4.4 ERDSS application

The SSE building retrofit optimization is conducted with ERDSS (model equations and development process discussed earlier in chapter 3). Building information is initially required, such as: building area (32,791.36 m²), building total annual energy consumption (13,367,293kWh), energy-unit price (LE /kWh), and expected inflation rate. Finally, the allocated budget for the retrofit is needed.

The dynamic programming helps facilitating the calculations for the ERDSS. Also it helps to solve a complex problem by breaking the problem down into a number of simpler sub-problems, each of those sub-problems is solved just once. Their solutions are stored in the software database library, as the EDRSS depends on a memory-based data structure through LabVIEW. In the next time the same sub-problem occurs, the model search engine simply looks up the previously computed solution, instead of re-computing its solution. Thereby, saving computation time at the expense of a modest expenditure on storage space.

In order to achieve the goals of dynamic programming, the database information is divided into three sections. These sections represent the three systems that have the largest impact in building energy consumption, as recommended by retrofit actions in AERG. This

is essential to direct any given capital investment to the most cost-effective group of energy saving measures. In order to achieve this, the measures must be ranked according to SIR.

EDRSS provide two operation approaches. The first approach helps the user to identify the retrofit measures that can be applied for the selected building and need to prioritize the retrofit measures plan according to the expected SIR order. The second approach is scenarios generation screen where it provides the user with all the possible retrofit scenarios for this building arranged according to SIR within the allocated budget. The optimization engine selects measures from the database according to the building area, current energy consumption, and budget limitation. The model is designed to calculate each measure initial cost and the expected SIR. The user can select any scenario to get a detailed report for it as shown in figure (4-13) (appendix A).

There are some operational measures with no investment cost, such as controlling the operation schedule using the BMS. The model is designed to present such activities if the user selects the retrofit budget to be 0, because they will be of no cost to the investor but will nevertheless achieve savings.

An optimization report presents the retrofit scenario measures and their calculations (i.e.: expected annual energy savings, annual savings cost, investment cost, total lifetime savings, SIR priority, and conformity with the given budget) will be also generated.

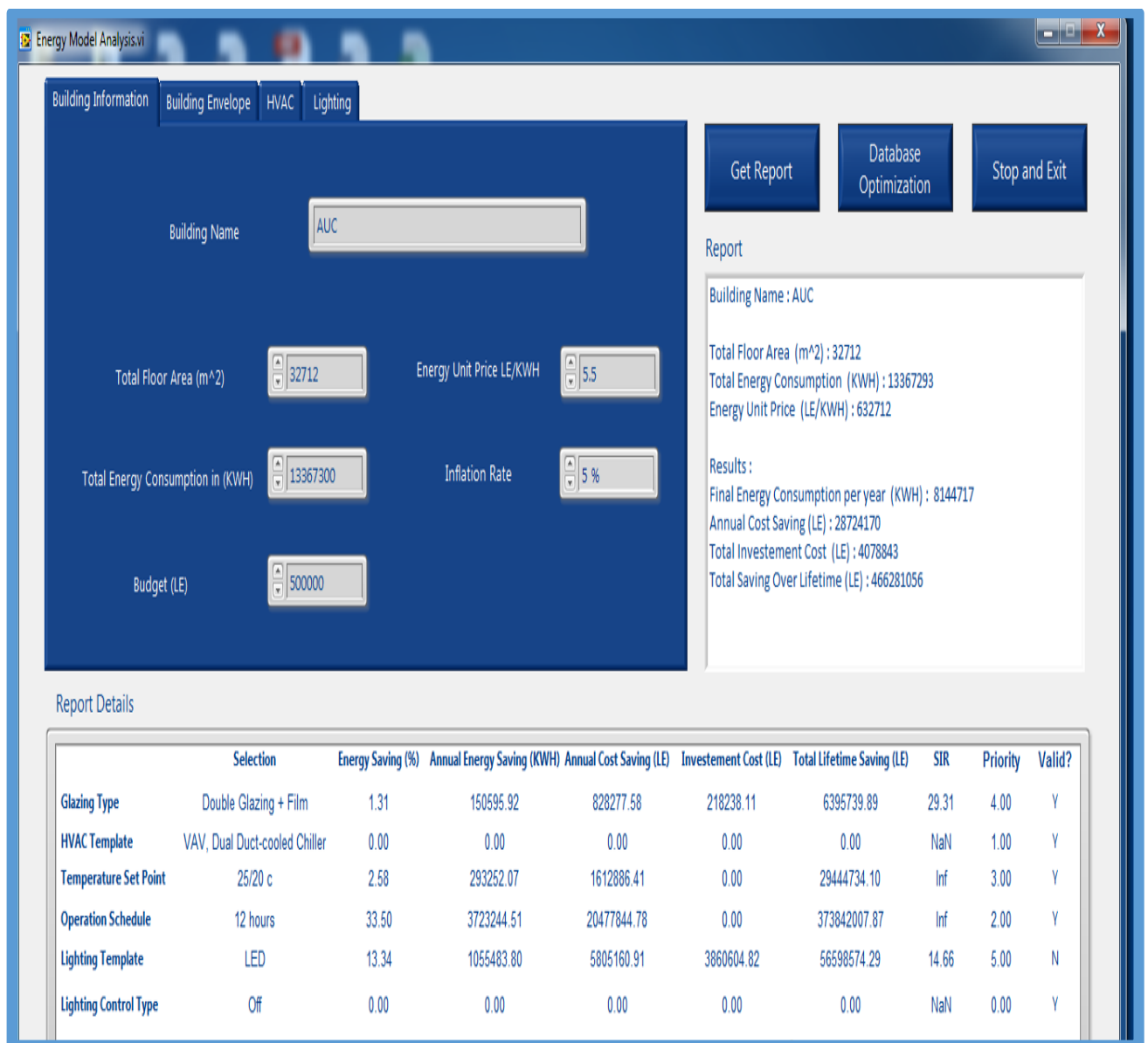

Figure (4-13) EDRSS Scenario generation

The second level of needed information is related to retrofit alternatives such as, building envelope, windows, and glass type. For the HVAC sub-screen, data including interior summer and winter indoor temperatures, operation hours, and list of systems. On lighting sub-screen, lighting and control type are selected from the database dropdown menu.

Finally, after the data input is entered through the (ERDSS) model, the optimization engine runs to select an optimum retrofit scenario that maximizes the saving-to –investment- ratio then prioritizes the other scenarios accordingly within the budget limitations. The user’s selection depends on building condition and covers the area for improvements, as shown in figure (4-14).

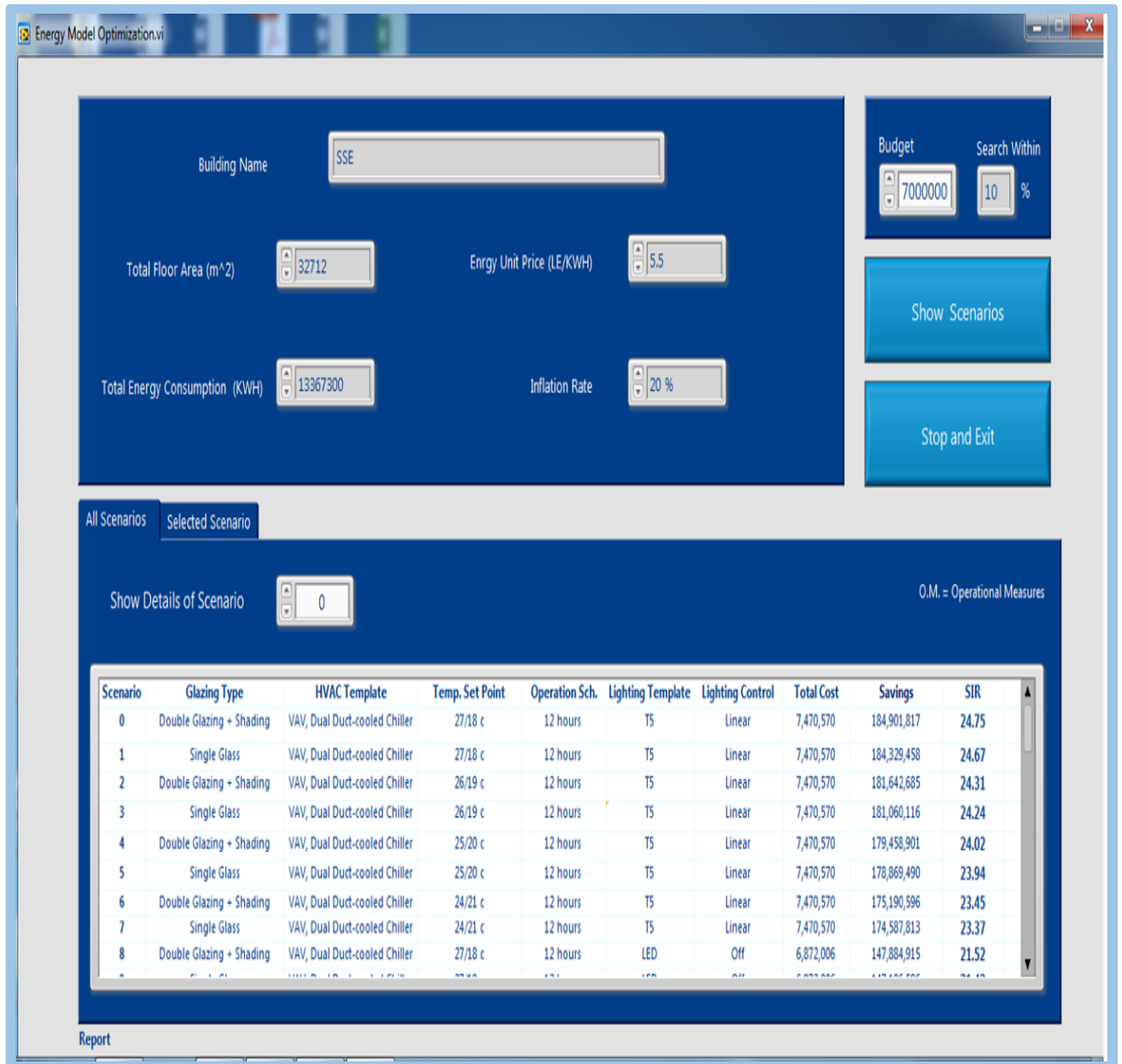

Figure (4-14) EDRSS Scenarios

4.4.1 ERDSS optimization results

The ERDSS optimization engine prioritizes initially the operational measures that have no initial costs such as reducing operation hours to be 12 hours instead of 18 hours. BMS can be programmed according to the actual space operation schedule according to space functions. For temperature controls, the set point should be decreased by 2°C.

The model then displays the possible retrofit scenarios meeting the building retrofit criteria within the available budget which depends on administrative decision on budget allocation priority, expected inflation ratio, and considering budget tolerance percentage. For example, if the retrofit budget for SSE building was 8,000,000 L.E with 10% tolerance, ERDSS recommendations would be:

- Changing LED lamps and fixtures initial cost 3,860,000 LE and adding new lighting linear controls 4,459,168 LE
- Adding film to double glass windows with initial cost of 218,238 LE as shown in figure (4-15).

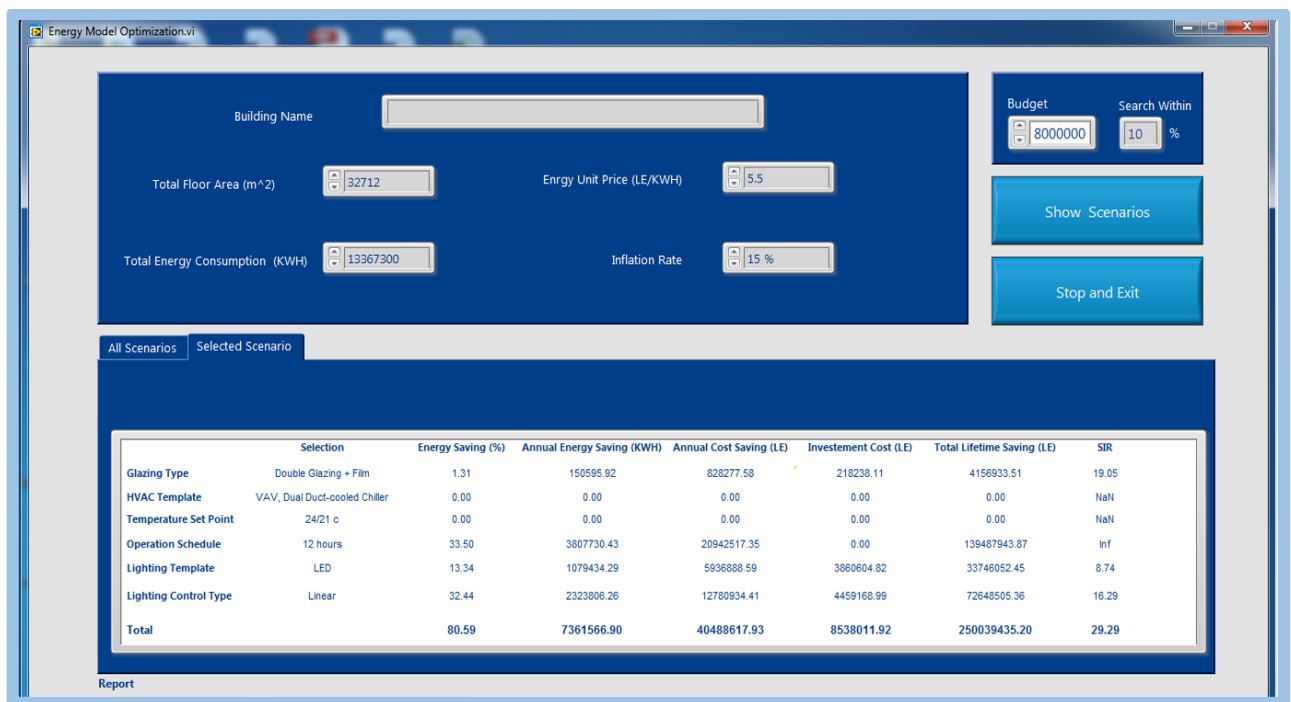

Figure (4-15) SSE optimum scenario results from ERDSS

The ERDSS database is not limited to the shown measures; rather it is flexible enough to add more measures using the same approach, to provide a variety of retrofit options for the user to select from.

The above case study shows that a decision support system can help the building operators to identify their retrofit priorities within the allocated budget. However, it makes more sense if the amount of savings is represented in numbers and percentages. Thus, a comparative analysis is done to show the energy savings of the selected retrofit measures by comparing them to their equivalent in the real application of the SSE building. In parallel with this research, the building discussed in the previous case study was assessed once more after a number of operational retrofit actions already took place in the SSE building over the last three years. Commissioning achieved good savings results. Over the three-year plan, AUC's total energy consumption has been reduced by more than 35% university-wide. The SSE building optimization results from ERDSS shows 38% energy savings prediction for adapting the same operational measures with a percentage of error 3%. This shows good alignment between model and actual measurement. Therefore, the EDRSS results for the optimum retrofit plan targeting the standard and deep retrofit options can help in developing the future budget planning matrix and help decision makers to prioritize campus buildings retrofit plan according the SIR for each building.

4.5 Conclusion

This chapter discusses model validation by applying energy retrofit decision support system on a real case study, the SSE educational building in New Cairo, Egypt. The model is applied using building energy simulation software tool and actual BMS monitoring system readings as a measurement-based approach for energy performance assessment for

diagnosis. Market research has been conducted to estimate the initial cost for different retrofit measures. The cost will change from one year to the other, therefore the user has the option to revise and update the unit rates in the database. Both simulation outputs and cost information are used to develop the database. The target of the database is to feed ERDSS model with the needed information to perform optimization process in order to identify the best retrofit scenario within the allocated budget, which was implemented in the SSE building.

The next chapter will provide research conclusions and recommendations for future study.

CHAPTER 5

Conclusions and Recommendations for Future Research

Chapter 5: Conclusions and Recommendations

5.1 Summary

The retrofits approaches vary from one building to another. The range of retrofit measurements generates a large number of retrofit alternatives which causes confusion to the building operators to take a certain retrofit decision. The retrofit scenario selection depends on the tradeoff between initial retrofit cost and expected energy savings. This creates the need for energy retrofit decision support tool to help decision makers to select the retrofit scenario which can achieve the highest energy savings within the allocated retrofit budget.

In this research, an integrated Energy Retrofit Decision Support System (EDRSS) framework with optimization features was developed to provide an optimum retrofit scenario for an existing educational building. The model was used to recommend the optimum retrofit scenario within the budget constraints. EDRSS was developed using LabView software in parallel with the use of energy simulation to generate output results using “database library” that are later used to achieve optimum solutions.

The proposed framework was applied on a case study of an educational building located in Cairo-Egypt and results show that, the optimum available retrofit scenario with budget limitation would direct the building operators to control the building operation. Different energy retrofits actions are tested using energy simulation software, and the results prove that it can achieve remarkable savings in a building’s operational annual budget. Cost calculation is performed to show the effect of electricity prices change on payback period and saving to investment ratio. The savings resulted from the commissioning retrofit reached

15%, standard retrofits 35%, and finally deep retrofit 45%. This framework and cost calculations can be very useful for building owners from many perspectives.

5.2 Recommendations for encouraging green retrofit

The government can play an important role in supporting green retrofits, particularly focusing on:

- New laws and regulations for enforcement of applying the green standards in all new buildings, and new codes for upgrading the existing buildings.
- Offering new investment measures to facilitate and encourage private sector investment in greening existing buildings. These measures would include providing governmental funding facilities or grants for bank loans for green retrofit, lower price rates for utilities (water, electricity, gas) and for buildings, which achieve lower carbon footprint results.
- Developing awareness campaigns regarding the importance of the energy savings and its results
- Starting a plan for applying green retrofit for existing buildings for all governmental buildings in Egypt, to help reduce energy consumption and provide a role model for the private sector.
- Increasing energy prices to constrain energy usage and motivate building owners from the private sector to search for energy efficient approaches to decrease their operation costs. The environmental benefits on the other hand would satisfy the occupants, improve their health, and increase productivity. Accordingly, the greening of existing buildings (especially private universities, such as in the case study) would be very useful to invest in to achieve considerable savings.

5.3 Future Research

This section lists and goes through some possible directions for future research. These directions could be summarized as follows:

- The next phase of research would be to test more retrofit measures such as using solar system as a clean energy source , green roofs and adding energy card readers in offices. This will enrich the model library database and facilitate the selection of retrofit actions to achieve optimum results.

- Applying the same framework on other building types (office buildings, residential buildings, etc.) By taking into consideration the different users requirements and building operation approach for each type, in order to guarantee a more accurate and precise saving to investment calculation.

- Adding deterioration modules for building systems to develop a notification system for early deep retrofit plans based on each system lifetime.

References

- Alanne, K. (2004). Selection of renovation actions using multi-criteria “knapsack” model. *Automation in Construction*, 13(3), 377–391.
- Arias, Andrea. (2013). Facade retrofit: enhancing energy performance in existing buildings: University of Southern California Dissertations and Theses. p15799coll3/id/352554
- Asadi, E., Silva, M. G. da, Antunes, C. H., & Dias, L. (2012). Multi-objective optimization model for building retrofit strategies. *Ibpsa-usa journal*, 5(1), 17–24.
- Asadi, E., Gameiro da Silva, M., Antunes, C., & Dias, L. (2012). A multi-objective optimization model for building retrofit strategies using TRNSYS simulations, GenOpt and MATLAB (Vol. 56), 370-378.
- Assad, M., Hosny, O., Elhakeem, A., & Haggag, S. E. (2015). Green building design in Egypt from cost and energy perspectives. *Architectural Engineering and Design Management*, 11(1), 21–40.
- Chau, C. K., Tse, M. S., & Chung, K. Y. (2010). A choice experiment to estimate the effect of green experience on preferences and willingness-to-pay for green building attributes. *Building and Environment*, 45(11), 2553–2561.
- Diakaki, C., Grigoroudis, E., Kabelis, N., Kolokotsa, D., Kalaitzakis, K., & Stavrakakis, G. (2010). A multi-objective decision model for the improvement of energy efficiency in buildings. *Energy*, 35(12), 5483–5496.
- Duah, D., Syal, M. (2016). Intelligent decision support system for home energy retrofit adoption. *International Journal of Sustainable Built Environment*, 5(2), 620–634.

- D'Agostino, D., Zangheri, P., & Castellazzi, L. (2017). Towards Nearly Zero Energy Buildings in Europe: A Focus on Retrofit in Non-Residential Buildings. *Energies*, 10(1), 117.
- El-Megharbel, N. (2015). Sustainable Development Strategy: Egypt's vision 2030 And Planning Reform.
- EEDC, Egypt Economic Development Conference, Sustainable development strategy Egypt's vision 2030 and medium term investment framework.
- Ferreira, J., Pinheiro, M. D., & Brito, J. de. (2013). Refurbishment decision support tools review—Energy and life cycle as key aspects to sustainable refurbishment projects. *Energy Policy*, 62, 1453–1460.
- American Society of Heating, Refrigerating and Air-Conditioning Engineers (Ed.). (2015). ASHRAE winter conference: January 24 - 28, 2015, Chicago, Illinois; [technical papers]. Atlanta, Ga: ASHRAE.
- Jaggs, M., & Palmer, J. (2000). Energy performance indoor environmental quality retrofit — a European diagnosis and decision making method for building refurbishment. *Energy and Buildings*, 31(2), 97–101.
- Juan, Y.-K., Kim, J. H., Roper, K., & Castro-Lacouture, D. (2009). GA-based decision support system for housing condition assessment and refurbishment strategies. *Automation in Construction*, 18(4), 394–401.
- Junghans Antje. (2013). Decision support model for energy-efficient improvement of entire building stocks. *Facilities*, 31(3/4), 173–184.
- Lee, S., Lee, B., Kim, J., & Kim, J. (2013). A financing model to solve financial barriers for implementing green building projects. *The Scientific World Journal*, 2013.
- Lee, S. H., Hong, T., Piette, M. A., & Taylor-Lange, S. C. (2015). Energy retrofit analysis toolkits for commercial buildings: A review. *Energy*, 89, 1087-1100

- Liu, G., Liu, B., Wang, W., Zhang, J., Athalye, R. A., Moser, D., & Hatten, M. (2011). Advanced energy retrofit guide office buildings (No. PNNL-20761). Pacific Northwest National Laboratory (PNNL), Richland, WA (US).
- Mahlia, T. M. I., Razak, H. A., & Nursahida, M. A. (2011). Life cycle cost analysis and payback period of lighting retrofit at the University of Malaya. *Renewable & Sustainable Energy Reviews*, 15(2), 1125–1132
- Makowski, M. (2010). Multi-objective decision support including sensitivity analysis. *Environmental Systems-Volume III*, 17.
- Menassa, C. C. (2011). Evaluating sustainable retrofits in existing buildings under uncertainty. *Energy and Buildings*, 43(12), 3576–3583.
- MEREAR. (2015) Egypt Expenses. Retrieved 2016, from Central Agency for Public Mobilization and Statistics: [<http://www.capmas.gov.eg>].
- Moser, D., Liu, G., Wang, W., & Zhang, J. (2012). Achieving Deep Energy Savings in Existing Buildings through Integrated Design. *ASHRAE Transactions*, 118(2).
- Oree, V., Khoodaruth, A., & Teemul, H. (2016). A case study for the evaluation of realistic energy retrofit strategies for public office buildings in the Southern Hemisphere. *Building Simulation*, 9(2), 113–125.
- Pereira, N. C. (2008). Retrofit Options for Increasing Energy Efficiency in Office Buildings-Methodology Review.
- Rosenfeld, Y., & Shohet, I. M. (1999). Decision support model for semi-automated selection of renovation alternatives. *Automation in Construction*, 8(4), 503–510.
- Silveira Marques Pereira, Charbel Jabbour, Sonia V.W. Borges de Oliveira, & Adriano Alves Teixeira. (2013). Greening the campus of a Brazilian university: cultural challenges. *International Journal of Sustainability in Higher Education*, 15(1), 34–47.

- Stadler, M., Groissböck, M., Cardoso, G., & Marnay, C. (2014). Optimizing Distributed Energy Resources and building retrofits with the strategic DER-CAModel. *Applied Energy*, 132, 557–567.
- Tatari, O., & Kucukvar, M. (2011). Cost premium prediction of certified green buildings: A neural network approach. *Building and Environment*, 46(5), 1081–1086.
- United States Green Building Council, 2009.
- Von Paumgarten. (2003). The business case for high performance green buildings: Sustainability and its financial impact. *Journal of Facilities Management*, 2(1), 26–34.
- Wang, S., Yan, C., & Xiao, F. (2012). Quantitative energy performance assessment methods for existing buildings. *Energy and Buildings*, 55, 873–888.
- Zhenjun. Ma, Cooper, P., Daly, D., & Ledo, L. (2012). Existing building retrofits: Methodology and state-of-the-art. *Energy and buildings*, 55, 889-902

Appendices

Appendix A:

A.1 Simulation report (Base line)

A.2 BMS annual readings

A3 ERDSS lab View Design Screens

A.4 ERDSS user interface Screens

A.1 Simulation report (Base line)

3/25/2017

Building RA (01-01:31-12) ** Cairo Intl Airport Al Qahirah EGY ETMY WMO#=623660 2017-03-24 16:29:39 - EnergyPlus

Program Version: EnergyPlus, Version 8.5.0-c87e61b44b, YMD=2017.03.24 16:29

[Table of Contents](#)

Tabular Output Report in Format: HTML

Building: Building

Environment: RA (01-01:31-12) ** Cairo Intl Airport Al Qahirah EGY ETMY WMO#=623660

Simulation Timestamp: 2017-03-24 16:29:39

Report: Annual Building Utility Performance Summary

[Table of Contents](#)

For: Entire Facility

Timestamp: 2017-03-24 16:29:39

Values gathered over 8760.00 hours

Site and Source Energy

	Total Energy [kWh]	Energy Per Total Building Area [kWh/m2]	Energy Per Conditioned Building Area [kWh/m2]
Total Site Energy	8879519.86	270.79	270.79
Net Site Energy	8110635.05	247.34	247.34
Total Source Energy	17318433.41	528.14	528.14
Net Source Energy	14883375.20	453.88	453.88

Site to Source Energy Conversion Factors

Site=>Source Conversion Factor	
Electricity	3.167
Natural Gas	1.092
District Cooling	1.056
District Heating	3.640
Steam	0.250
Gasoline	1.050
Diesel	1.050
Coal	1.050
Fuel Oil #1	1.050
Fuel Oil #2	1.050
Propane	1.050
Other Fuel 1	1.000
Other Fuel 2	1.000

Building Area

	Area [m2]
Total Building Area	32791.36
Net Conditioned Building Area	32791.36
Unconditioned Building Area	0.00

End Uses

	Electricity [kWh]	Natural Gas [kWh]	Additional Fuel [kWh]	District Cooling [kWh]	District Heating [kWh]	Water [m3]
Heating	0.00	0.00	0.00	0.00	70527.22	0.00
Cooling	0.00	0.00	0.00	5137527.03	0.00	0.00
Interior Lighting	2754020.16	0.00	0.00	0.00	0.00	0.00
Exterior Lighting	436.95	0.00	0.00	0.00	0.00	0.00
Interior Equipment	894457.34	0.00	0.00	0.00	0.00	0.00
Exterior Equipment	0.00	0.00	0.00	0.00	0.00	0.00
Fans	0.00	0.00	0.00	0.00	0.00	0.00
Pumps	0.00	0.00	0.00	0.00	0.00	0.00
Heat Rejection	0.00	0.00	0.00	0.00	0.00	0.00
Humidification	0.00	0.00	0.00	0.00	0.00	0.00
Heat Recovery	0.00	0.00	0.00	0.00	0.00	0.00
Water Systems	0.00	0.00	0.00	0.00	22551.16	431.60
Refrigeration	0.00	0.00	0.00	0.00	0.00	0.00
Generators	0.00	0.00	0.00	0.00	0.00	0.00
Total End Uses	3648914.46	0.00	0.00	5137527.03	93078.38	431.60

Note: District heat appears to be the principal heating source based on energy usage.

End Uses By Subcategory

file:///C:/Users/AUC/Desktop/1.htm

1/18

A.2 BMS annual readings

AUC New Campus Energy Consumption			
	Base Year	Year 1	Year 5
September	10,196,792	8,414,248	6,891,496
October	9,115,636	6,580,552	5,969,852
November	7,124,370	5,102,175	3,998,269
December	6,641,181	5,263,310	3,769,144
January	6,234,672	5,534,659	4,051,239
February	5,194,121	5,484,704	3,959,397
March	6,910,984	5,013,292	4,027,318
April	6,976,573	4,787,871	4,292,050
May	8,134,294	6,368,337	5,671,075
June	8,994,176	6,837,317	5,723,207
July	9,189,846	7,099,811	5,979,900
August	8,618,145	5,367,259	7,422,411
TOTAL-kwhr	93,330,787	71,853,535	61,755,358

Year 2 to Year 1	16.08%
Year 3 to Year 2	12.85%
Year 4 to Year 3	-4.42%
Year 5 to Year 4	-9.84%
Year 6 to Year 5	0.10%
Cumulative(Year 6 to Base Year)	36.29%
Cumulative(Year 5 to Base Year)	36.23%
Cumulative(Year 4 to Base Year)	41.94%
Cumulative(Year 3 to Base Year)	44.40%

Table (A-1) AUC monthly energy consumption reading for six years (BMS Data and AUC annual sustainability report)

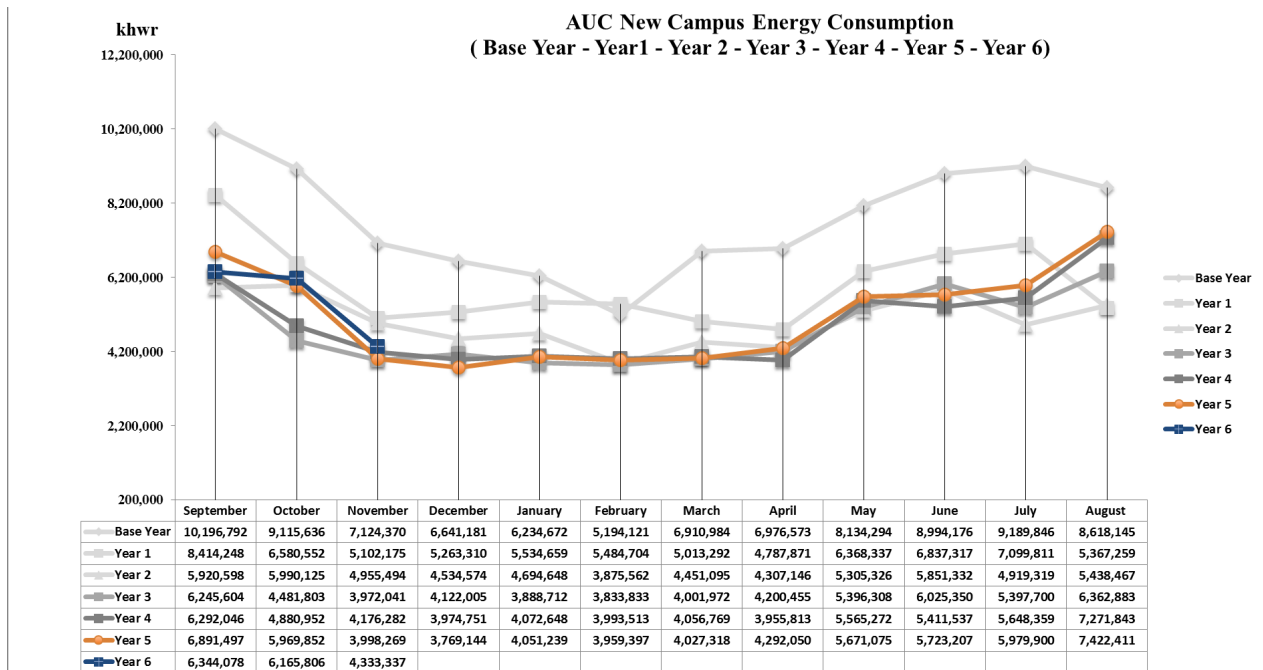

Figure (A-1) Chart of AUC monthly energy consumption for six years (BMS Data and AUC annual sustainability report

7.3 ERDSS Lab view design screens

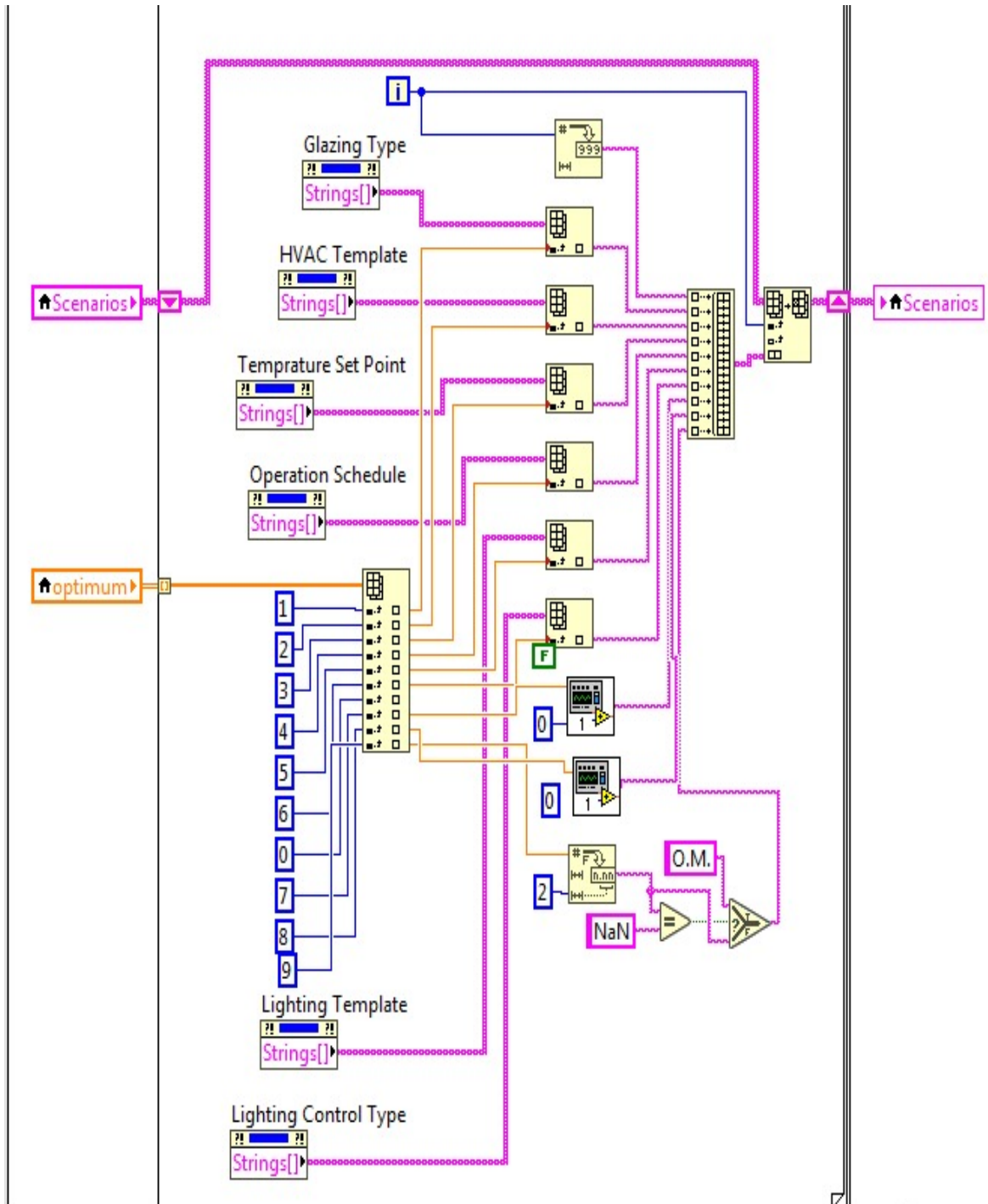
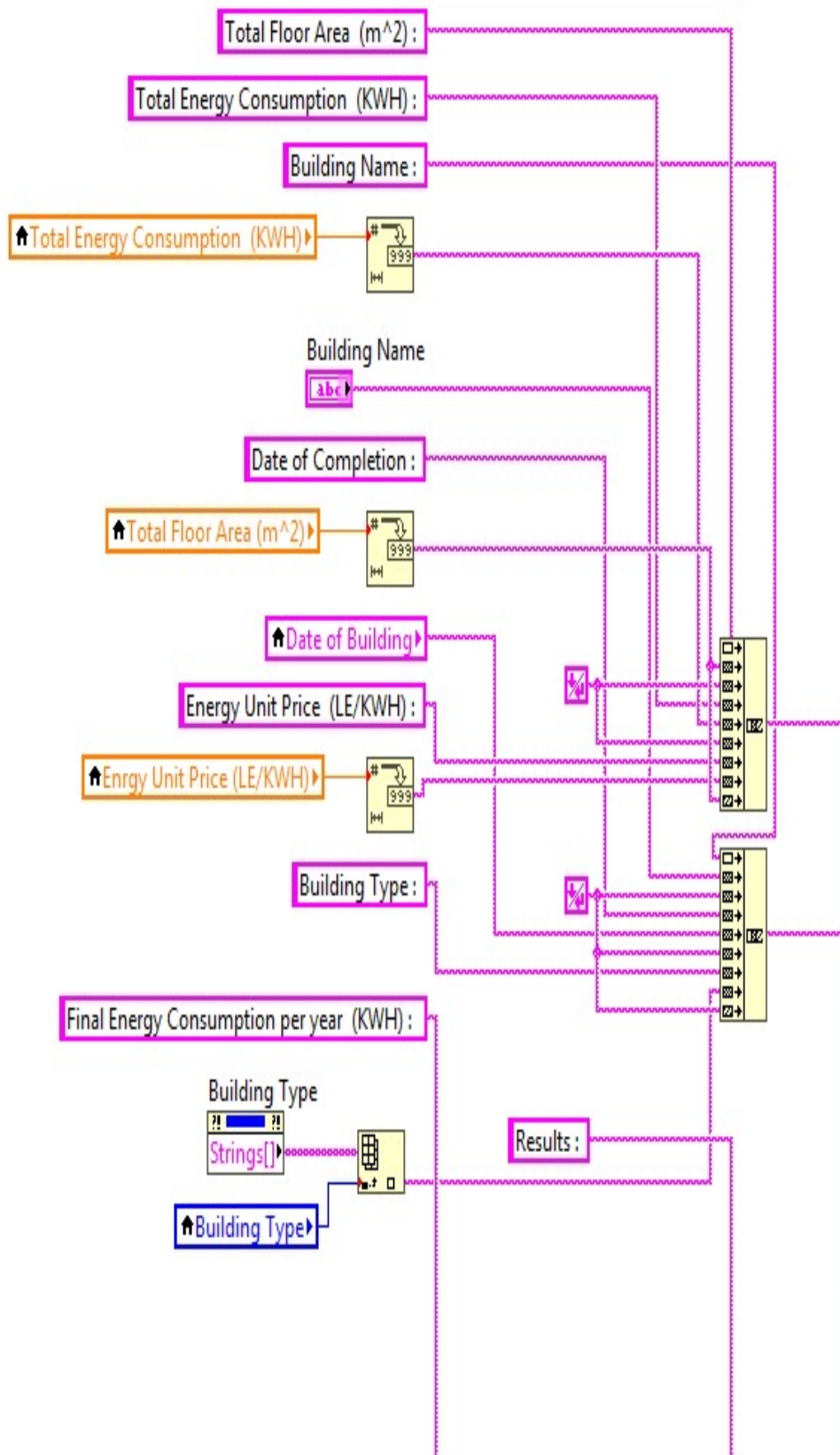

Figure (A-2) lab View tree structure design screens



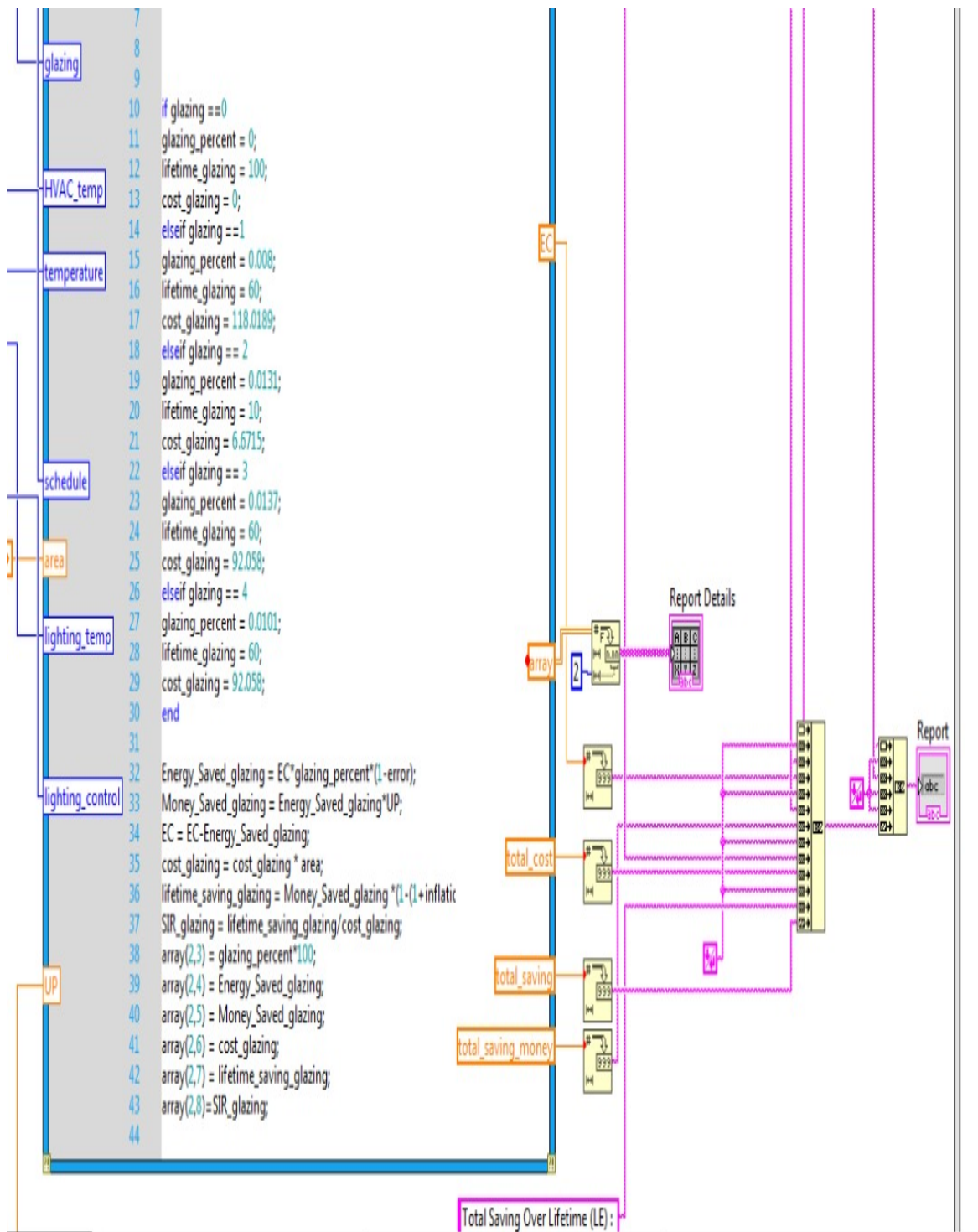

Figure (A-3) lab View cost trade-off analysis

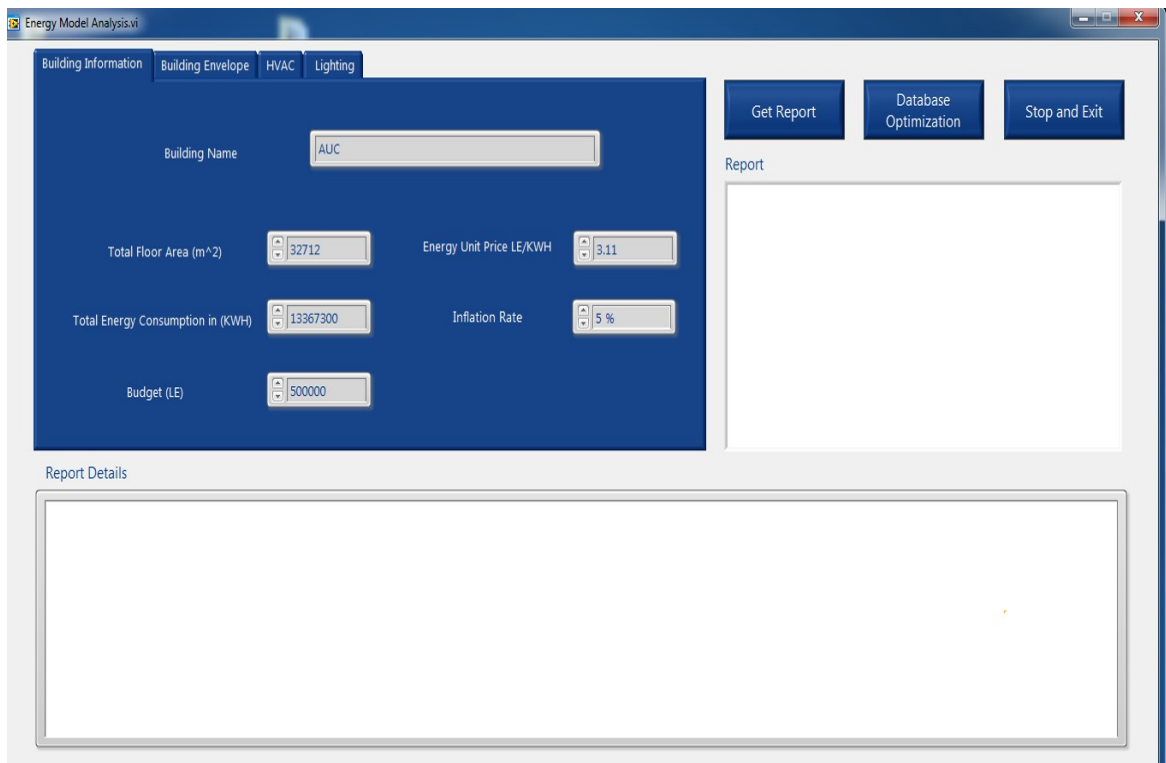

Figure (A-4) Building information Screen in ERDSM

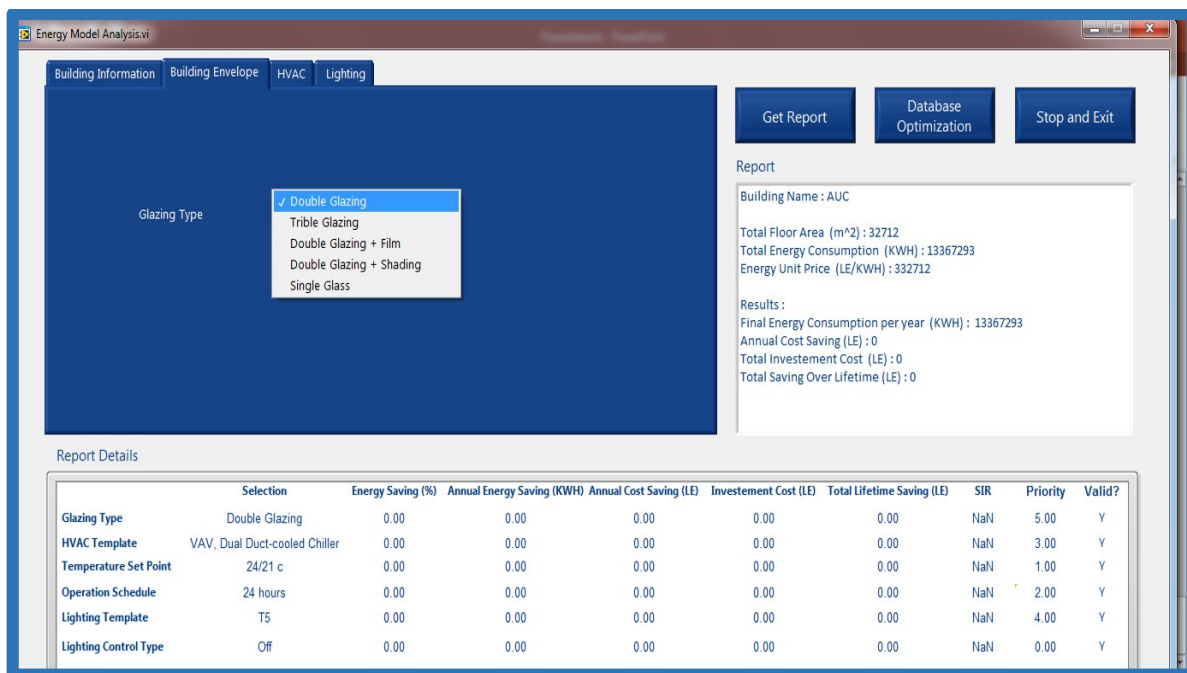

Figure (A-5) Building Envelope Screen in ERDSM

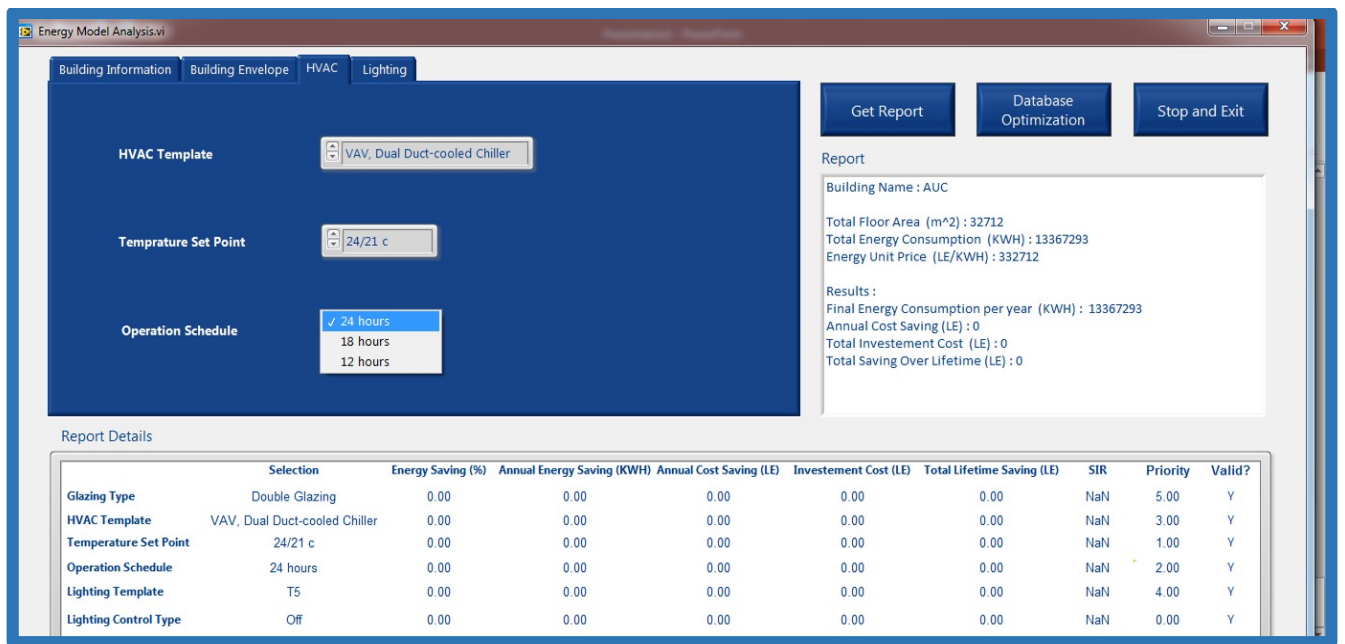

Figure (A-6) HVAC Screen in ERDSM

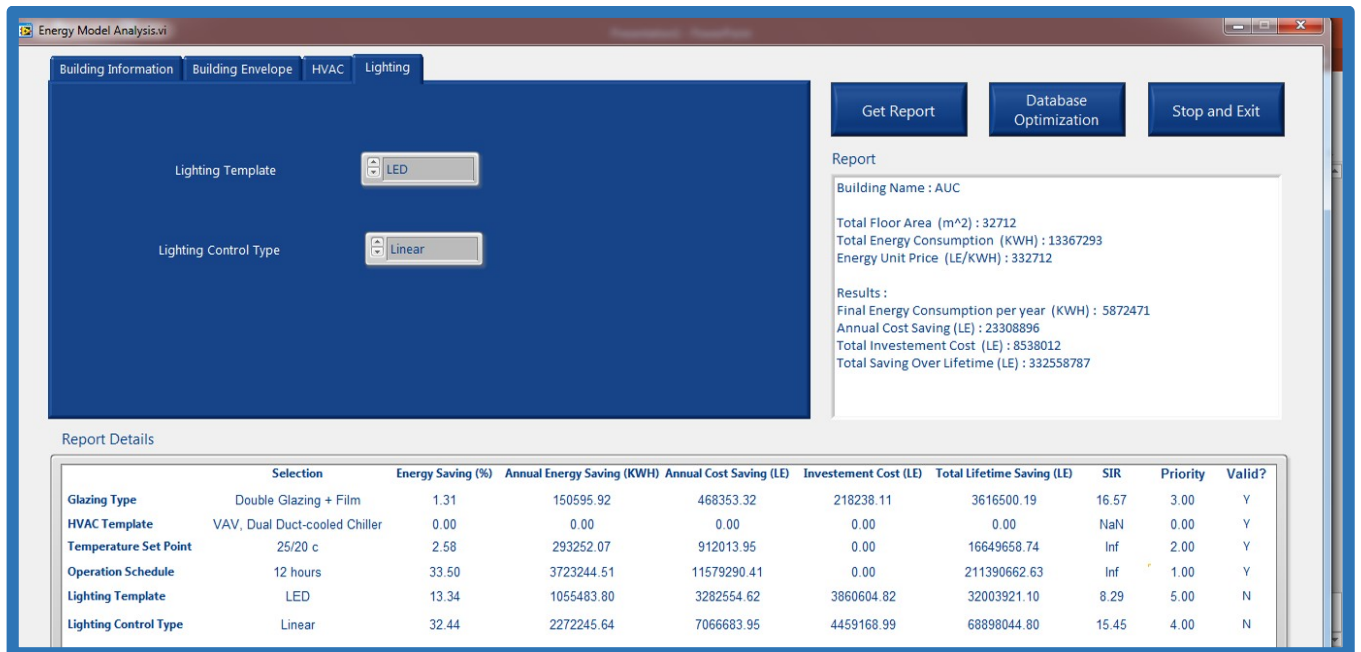

Figure (A-7) Lighting Screen in ERDSM

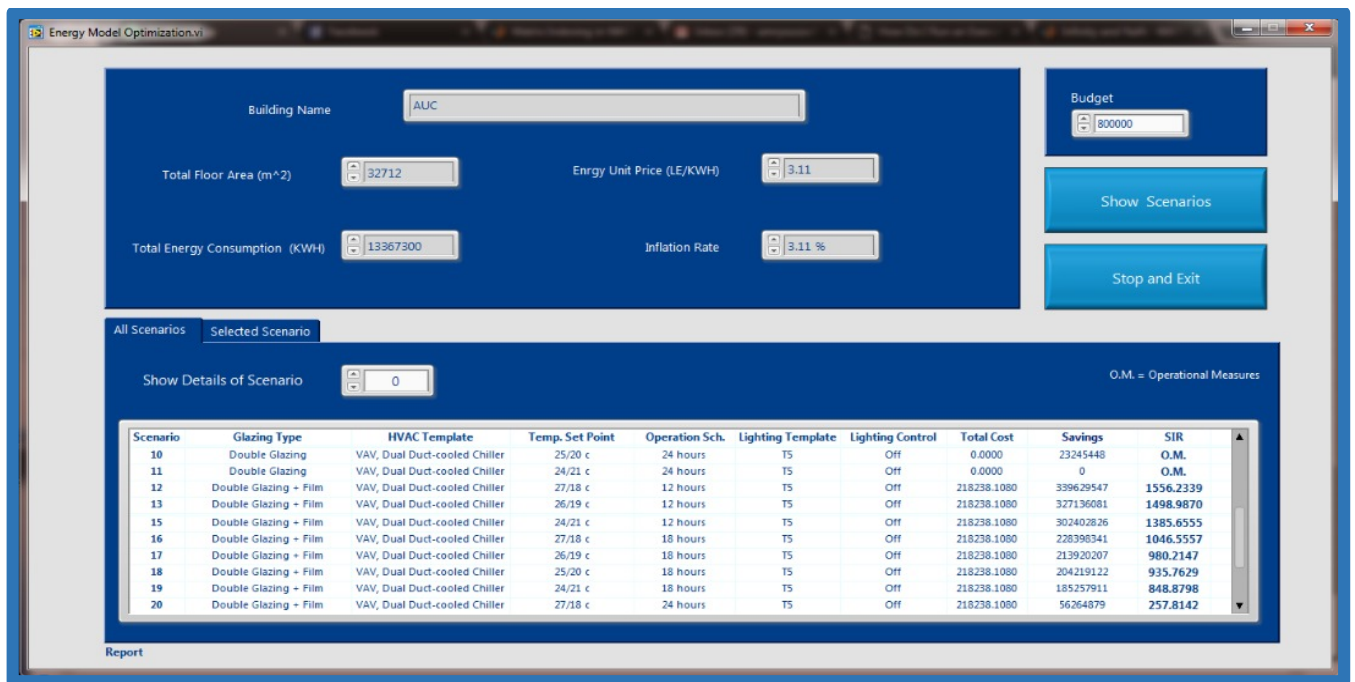

Figure (A-8) SSE Retrofit Measures Optimization scenarios report in ERDSM

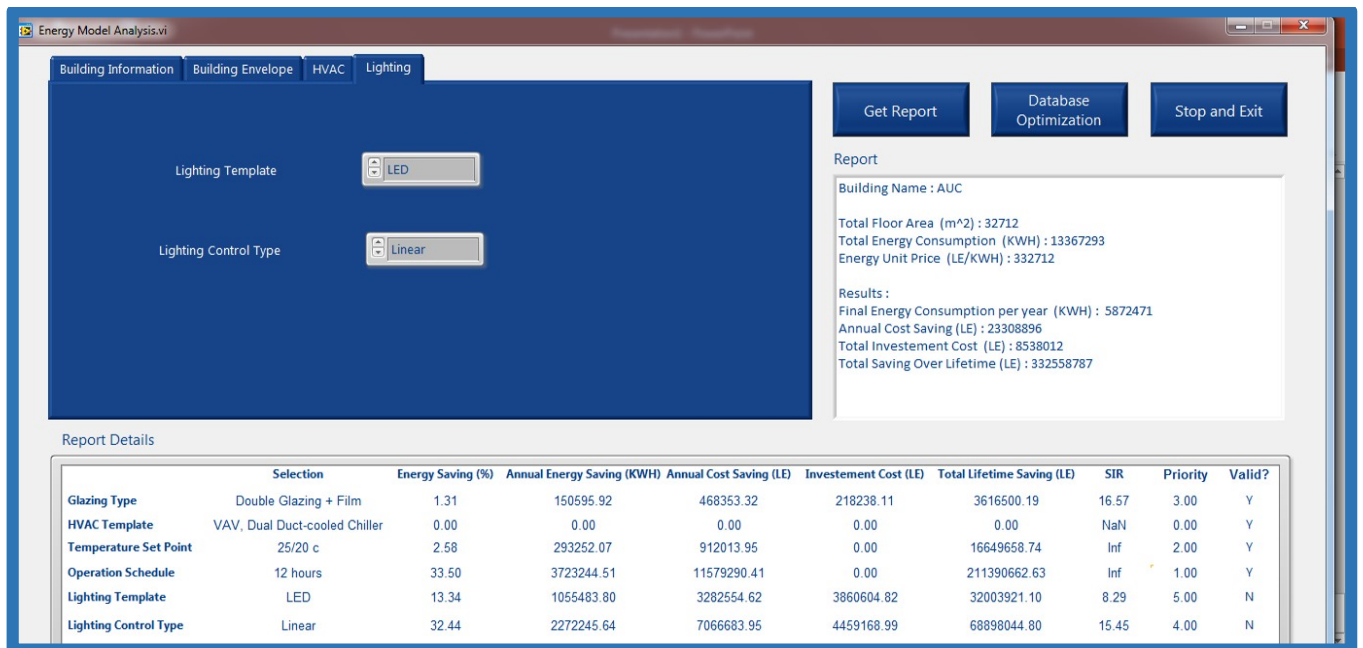

Figure (A-9) SSE Optimum retrofit scenario ERDSM