

# Tracked Vehicle Performance Evaluation using Multi Body Dynamics

S. Balamurugan and R. Srinivasan\*

*Hinode Technologies Pvt. Ltd., Chennai – 600 030, India*

*\*E-mail: r.srinivasan@hinode.in*

## ABSTRACT

The objective of the study was to shorten the design cycle and evaluate the performance of infantry fighting vehicle using advanced multi body dynamics (MBD) environment before physical prototypes built. The MBD model is built with tracked vehicle module consisting of tracks (Links), sprocket, Support rollers, and hydro pneumatic suspension with suitable connections. Hull, turret are characterised by mass and inertial properties. The dynamic analysis was carried out for different field conditions i.e. trench crossing, step and ramp climbing, etc., to extract the hull forces at joints, power required to maneuver, track tension forces to determine overall vehicle stability and look for possible design modifications. Recommendations were then suggested for power train, number of track segments, tensioner force, etc to ensure proper behaviour during different maneuvers. The MBD results are used in FEA to determine structural response in terms of stress, deformation, fatigue etc., and reflects in design modification before physical prototype made and are validated with base level analytical results.

**Keywords:** Multi body dynamics; Tracked; Design; Performance; Dynamic

## 1. INTRODUCTION

Infantry fighting vehicle (IFV) has an important task of carrying men and arms to provide assault, support and also move infantry into conflict zone. IFV offers flexibility and support to MBT in an armed conflict offering significant advantage in conflict and war zones. IFV as is commonly known is of:

- Wheeled one
- Tracked ones.

While wheeled one moves at high speed but it can't move on irregular surfaces. The tracked IFV offers greater flexibility in terms of off-road mobility. Some of the mobility requirements are obstacle climbing and moving over roadblock and even be amphibious. Hence tracked vehicles along with MBT can attack and operate from areas where wheeled vehicle cannot, which is a great tactical advantage. In-order to achieve the greater mobility in off road scenario and with the advent of urban warfare it is essential that the tracked vehicle is capable of meeting the requirements of various manoeuvres. Hence an IFV is tested against manoeuvres such as trench crossing, step climbing and Pivot steering.

As against physical testing which is time consuming, costly and cumbersome, virtual simulation of tracked vehicle offers higher value in terms of savings of time and cost. Using the tracked vehicle module of the leading MBD tool, IFV MBD model is generated consisting of tracks (Links), sprocket, Support rollers, and hydro pneumatic suspension with suitable connections. Hull, turret are characterised by their mass and inertial properties. The dynamic simulation of IFV was done for various field conditions such as step climbing, trench

crossing, bump crossing, grade ability, pivot steering, and acceleration at various speeds. From analysis, power, forces at joints, track segments and rollers are extracted to study the performance<sup>1</sup>. The methodology of virtual prototyping and simulations improves the design efficiency and reduces the number of design errors and iterations involved during physical prototype testing.

## 2. INFANTRY FIGHTING VEHICLE

### 2.1 General arrangement

Generally, IFVs have less complex and lighter armor than heavier tanks to ensure greater mobility. Most IFVs are resistant against heavy machine guns, artillery fragments, and small arms. The primary weapon on most IFVs is auto cannon; usually of a caliber between 20 mm – 40 mm. IFV cannons can tilt their barrels by as much as 70 degrees to permit their crews to engage even aircrafts.

A coaxial machine gun is mounted on the turret along with the main armament. Some IFVs are amphibious and air transportable throughout its life cycle, an IFV is expected to gain 30 per cent more weight from armour additions. All this complicates the design by requiring additional power and not compromising the mobility.

## 3. IFV MODEL BUILDING

### 3.1 IFV Modelling and Simulation

The tracked vehicle model is built based on CAD details and related inputs provided with the following sub systems as shown in Fig. 1.

- Hull and Turret
- Sprocket
- Idler

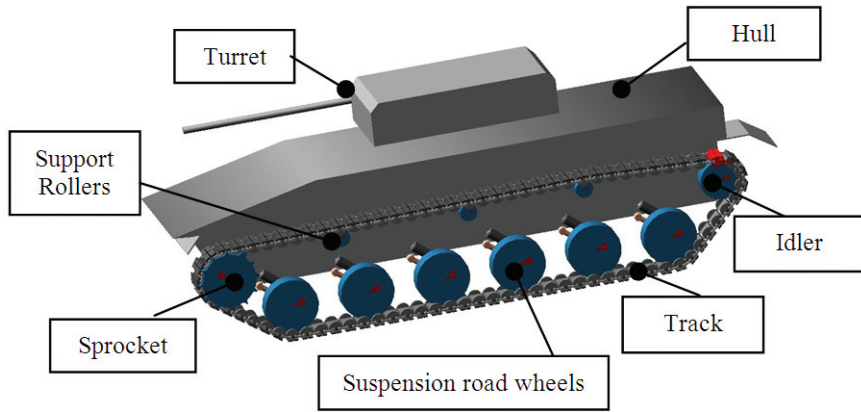

Figure 1. Various MBD subsystems.

- Suspension road wheels
  - Support rollers
  - Double pin track system
- Hull, turret are characterised by mass and inertial properties.

The model co-ordinate followed is same as vehicle coordinate convention as shown in Table 1.

Table 1. Coordinate system conventions

Co-ordinate system	Direction definition
Positive X - axis	Along the Sprocket centre positive towards rear.
Positive Y - axis	Along the Sprocket centre and vehicle centre positive towards top
Positive Z - axis	Along the centre of the vehicle positive towards RH side

3.2 Model Assumptions

- Parts are considered as rigid
- Default torque impact parameters
- The hydro pneumatic suspension system is modeled as a spring and damper system with the provided input stiffness and damping properties.
- All performance study except the pivot steering was performed using half vehicle setup.

3.3 Units

Throughout model design and analysis, MMKS (millimeter, kilogram, second) followed.

3.4 Challenges during Manoeuvres

3.4.1 Tip over phenomenon

In ramp climbing, when negotiating slopes of critical grade, vehicles tend to tip over about some pivot point. In theory, the critical point is reached when the centre of gravity (CG) of the vehicle is located vertically above its centre of rotation as shown in Fig. 2.

In practice, the actual critical angle is always less than the theoretical value during both static and dynamic operations<sup>2</sup>. Statically, the sagging of suspension members causes the CG to shift toward the centre of rotation. Dynamically, this condition is amplified by the torque imposed by the driveline, especially

when accelerating.

3.4.2 Idler Tensioning system

At higher speeds there is less tension in the tracks. This would cause problems for tracked vehicles which operate at high speeds. It is safe to assume that an idler tensioning system is reserved for vehicles that operate at low speeds, which is the case here.

The idler tensioning system is modelled as constant horizontal force that acts on the centre of the idler. Since the drive sprocket, road wheels and support rollers are all mounted rigidly, the force pushes the idler forward to create tension between the tracks. However, as the model begins to move, so does the position of the idler.

Large deflections in the idler tensioning system could have disastrous consequences on a tracked vehicle<sup>3</sup>. This is the motivation for measuring the distance between the idler and the drive sprocket.

4. PERFORMANCE STUDY

The performance of IFV was evaluated using simulation conditions provided by end user for different field conditions such as ramp climbing, step climbing for the given vehicle velocity

The test conditions such as trench length and depth, slope angle for ramp climbing, obstacle height and width for step climbing are also provided by customer.

4.1 Ramp Climbing

The gradient of 35° was modeled and vehicle simulated to run at given speed to study dynamic behaviour. Due to the data paucity associated and unacceptable level of long simulation hours (Indicating the incorrectness of the data) it is decided to drop the soft soil condition in this simulation<sup>4</sup>.

Maximum torque is required is at the sprocket, to keep the vehicle stable in the 35° slope as shown in Fig. 3. As a fallout of high torque at the sprocket, the track segment experiences heavy load due to tension in the system. By simulation, track tension observed at equilibrium condition is found to be lesser

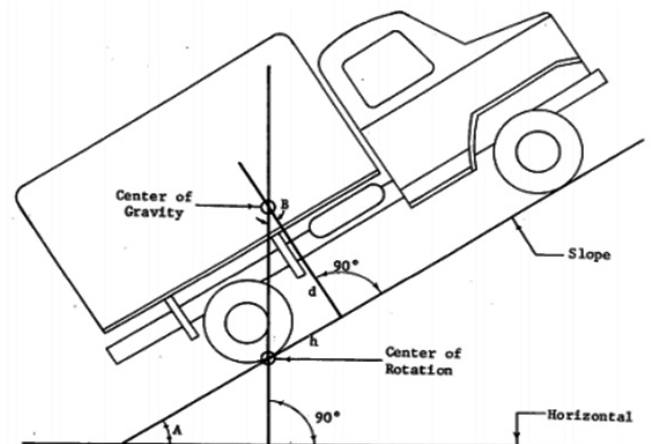

Figure 2. Tip over point during ramp climbing.

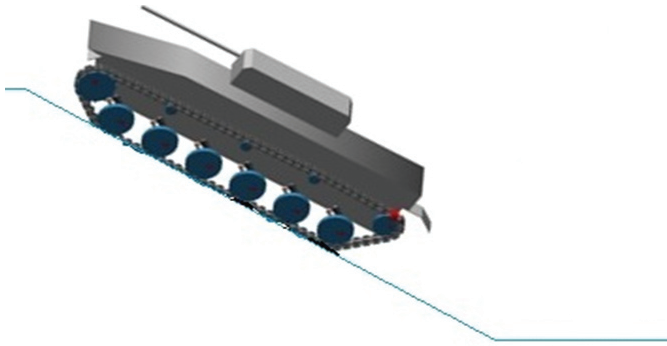

Figure 3. Ramp climbing of 35°.

value than required. It was adjusted by offsetting idler in rearward direction and axis inclined to achieve required track tension.

Also track segments found to be in excess than the ideal situation which causes the track slackness. This doesn't provide required track force. The track segments corrected to a sufficient number to ensure sufficient track length and proper running of vehicle in various performance study<sup>5</sup>. In addition, track slackness avoided. These are then communicated to the design.

#### 4.2 Step Climbing

Due to the urban warfare and conflicts, The Tracked vehicle will be subjected to manoeuvres like step climbing. Important challenge for the tracked vehicle is to have tip over stability while crossing the obstacles or step climbing. To simulate the same as per the data, an obstacle of height 800 mm was modelled as shown in Fig. 4, and vehicle simulated to run at given speed to study dynamic behaviour. The torque required to climb the step was plotted with respect to time. At high velocity, the track segment tends to slip away from the sprocket teeth. The sprocket diameter is adjusted to ensure proper sprocket teeth contact.

### 5. RESULTS

The tracked vehicle study was carried out using torque, velocity, and power curves for half symmetry model. The forces on hull at suspension pivot locations, track tension,

spring force and deflection are extracted from analysis for further study.

#### 5.1 Torque curve

##### 5.1.1 Ramp climbing

During ramp climbing, the sprocket torque starts to rise steadily as the vehicle has to be pivoted up by the sprocket. As the vehicle front starts to ramp upon the slope, the required torque increases and later held constant for a period till the acquired torque was sufficient to continue vehicle moving up the slope as shown in Fig 5(a). To keep up momentum, the sprocket applies increased torque as it continues on the slope and maintains the same for some period. This torque for ramp climbing is the maximum compared to other manoeuvres. The engine and transmission system study is recommended to check enough power to the vehicle.

##### 5.1.2 Step climbing

During step climbing, the sprocket torque is at a minimum level just enough to overcome static friction and move the vehicle forward as shown in Fig. 5(b). It rises to maximum when the drive sprocket starts to climb over the step. Then the torque fluctuates due to momentum due to vehicle mass shifting from front to rear until major portion of vehicle climbs over the step. The negative torque and pitching is predominant when vehicle exits the step, since the momentum due to the mass shifts from rear to front. The front road wheels takes up more load and

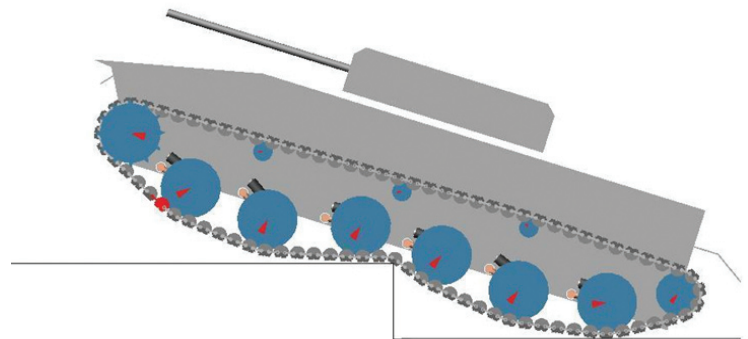

Figure 4. Step climbing of height 800 mm.

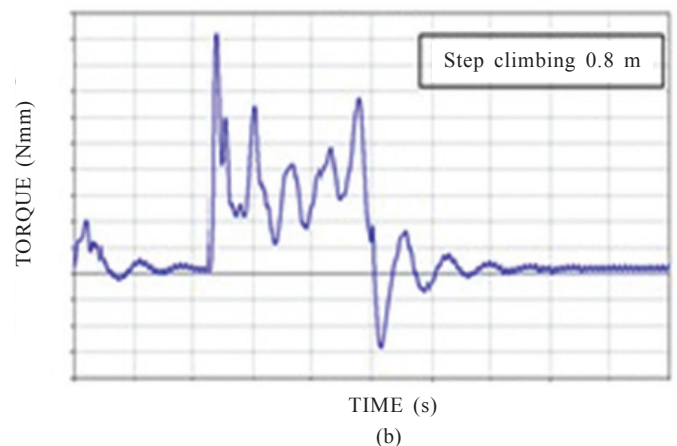
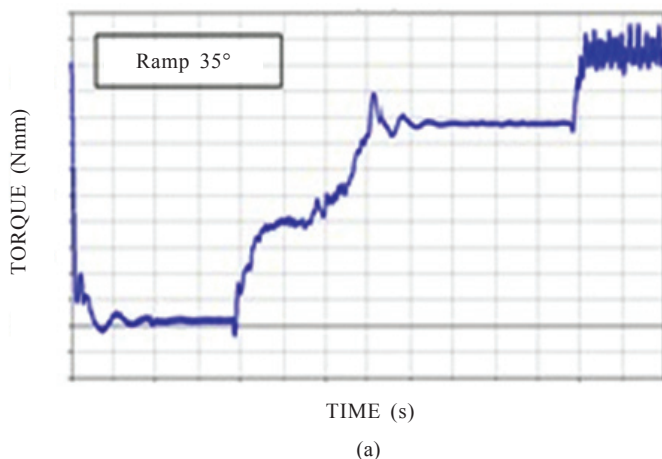

Figure 5. Torque curve during different manoeuvres: (a) Ramp climbing and (b) Step climbing.

spring compresses to maximum. The dampers control the rate of road wheel movement. During this manoeuvre, it is also observed that the vehicle’s design height was not maintained at desired value and hence spring preload was adjusted to avoid tank sinking and the same is conveyed to the design.

**5.2 Power curve**

The power curve has same pattern similar to torque curve with the relation,  $P \text{ (kW)} = 0.105 * T \text{ (N-m)} * N \text{ (rpm)}$  as shown in Figs. 6(a) and 6(b).

**5.3 Velocity profile**

Velocity profile for step and ramp climbing are extracted. The velocity is maintained at desired values during step climbing and fluctuation is observed during start and exit of step. The desired velocity is attained during ramp climbing and starts to decrease since the vehicle torque increases to climb up the given slope.

**5.4 Hull Forces**

The hull force extraction points are shown in Fig. 7. The numbering of road wheels from rear of vehicle. The forces from these pivot arm locations to hull plots discussed further.

**5.4.1 Vertical Forces from Pivot Arms**

The vertical hull forces from pivot arm of the road wheels are extracted during step climbing manoeuvre. From the results it is observed, that the road wheel which hits step first, transfers high force to hull. Subsequently, remaining road wheel and pivot arms experience high forces and at exit of the step, the forces decrease and remain constant.

**5.4.2 Track Tensional Force**

The track tension force is extracted from simulation. The track tension is maintained at a constant value during flat road conditions. The variation is noted during 5 s to 13 s in which step climbing occurs.

**5.4.3 Bending Moments at Pivot Points**

In addition to hull forces, hull experience torque/moment in both the horizontal axes (lateral and longitudinal) due to pivot arm offset from road wheel’s centre in lateral direction and the same were extracted from simulations.

The hull forces extracted is provided for downstream applications namely FEA analysis to find the structural adequacy and fatigue life of the critical components such as suspension arm pivot locations, track segments, turret, etc.,

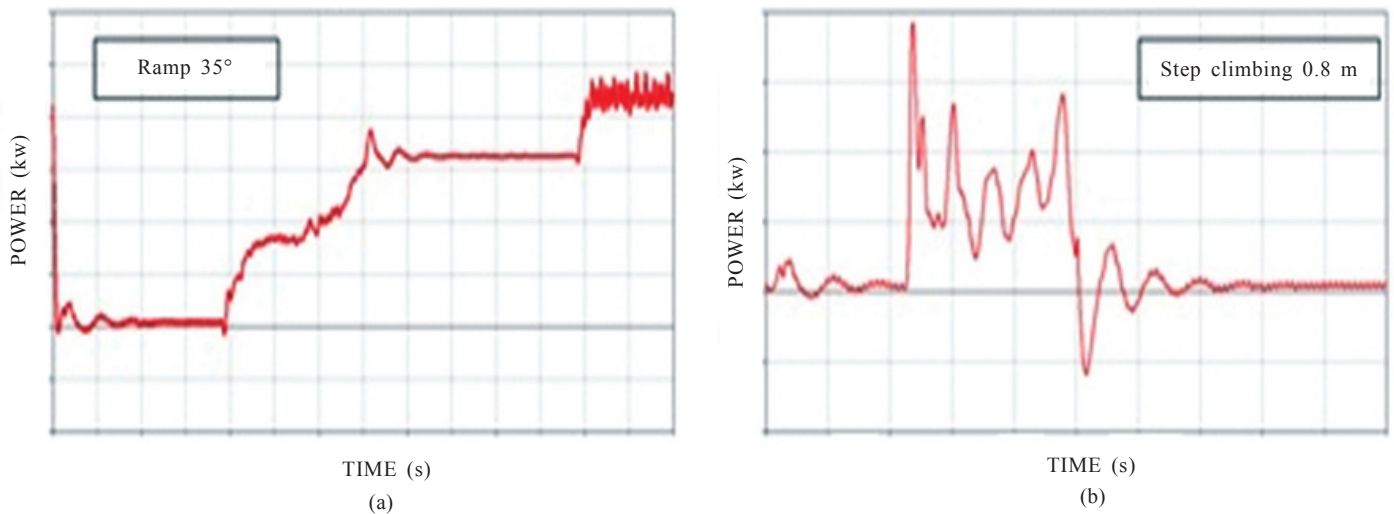

Figure 6. Power curve during different manoeuvres: (a) Ramp climbing and (b) Step climbing .

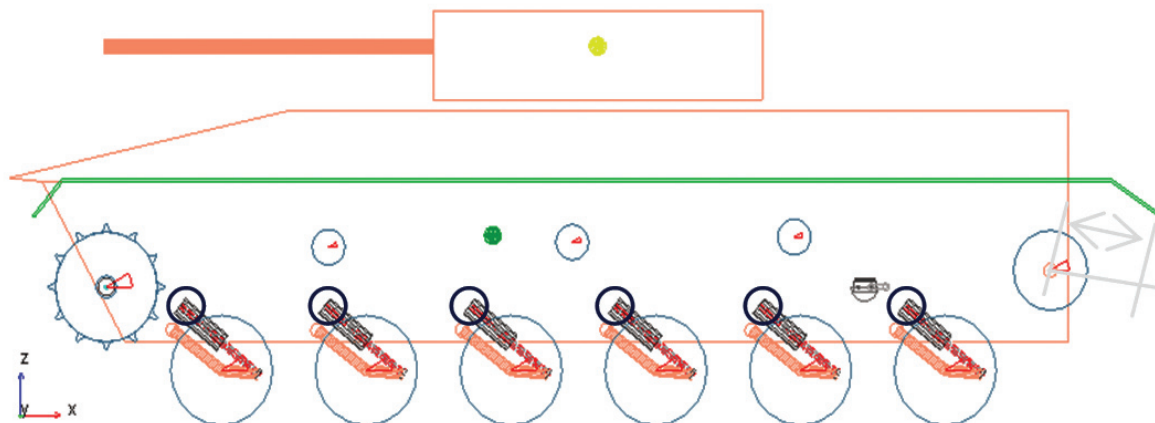

Figure 7. Force extraction at hull pivot locations (shown by blue circles).



## 6. FUTURE SCOPE

- The turret control system development for complex, robust, stable control is achieved by co simulating MBD model with control packages like Matlab/Simulink. For control logic modeling to provide smooth, proportional acceleration and control of the gun turret during various uneven road profile manoeuvres.
- By using flexible hull body, the structure can be evaluated static and dynamic loading and accordingly the possible weight rationalisation can be done for a stable, lighter at the same time safer hull for optimised performance.
- Detailed hydro-pneumatic suspension modeling.
- Soft-soil investigation.

## 7. CONCLUSIONS

The design and performance study of IFV were carried out using multibody dynamic toolkit and critical parameter modifications are recommended for performance evaluation. The torque, power, velocity profiles during various field manoeuvres were evaluated and studied for forces on hull and track segments. Multiple simulation cases with different track segments, idler alignment and contact stiffness were simulated to evaluate the vehicle characteristics and to focus on design refinement for better performance.

The methodology presented in this paper proves to be efficient both in time and cost for simulating different vehicle configurations and study its dynamic behaviour before physical prototyping and testing. The approach of Tracked vehicle simulation incorporating the flexibility of the hull and control system simulation present a future with even shorter evaluation effort and time of an Infantry fighting vehicle, compressing the overall development cycle.

## REFERENCES

1. MSC ADAMS Software manual/Help document.
2. Gillespie, T. Fundamentals of vehicle dynamics. Warrendale, PA : Society of Automotive Engineers. 1992.
3. Steeds, W. Tracked vehicles (in Three Parts). Automobile Engineer, 1950.
4. Bekkar, M.G. Introduction to terrain vehicle system. The University of Michigan Press.
5. Wong, J.Y. Theory of ground vehicles. Ed. 3. John Wiley & Sons.

## CONTRIBUTORS

**Mr S. Balamurugan**, holds a Master's in Mechatronics Engineering from VIT, Vellore. Currently he is working as a CAE – Engineer. Also has specialisation in Robotics from 'Ecole Centrale de Nantes', France. He has been executing projects for Indian and overseas customers for 2 years in controls, MBD and vehicle dynamics.

He had carried out the design study and results extraction and review in this project.

**Mr R. Srinivasan** is Director, Technical in Hinode Technologies Pvt. Ltd., He has done his Engineering in PSG College of Technology, Coimbatore and has worked in HCL NIIT, and Mechanical Dynamics Inc. His expertise in CAE is well over 25 Year.

He had built and simulated the MBD model of the tracked vehicle in this project.