

A Field Study on Concurrent Spare Parts Recommendation in an Airborne Weapon System

Giseop Noh[#] and Hayoung Oh^{*}

[#]*Division of Software Convergence, Cheongju University, South Korea*

^{*}*DASAN College, Ajou University, South Korea*

^{*}*E-mail: hyoh79@gmail.com*

ABSTRACT

As the complexity of weapon systems has grown exponentially during the past few years, initial operation capability has been a crucial factor for military forces. Concurrent spare parts (CSPs) is the quantity of spare parts ensuring initial operating period specified by demanding forces acquiring newly deployed weapon systems. Because of the growth of system complexity, recommending precise CSP is not trivial. The Republic of Korea developed an improved CSP recommendation system and deployed the system for naval weapon systems. In this paper, we increase the prediction accuracy of CSP up to 23.1 per cent and 7.16 per cent higher in terms of budget constraint and operational availability (A_o) constraint. The main improvement is achieved by facilitating simulations using the real field data from Korean air force. Also, we propose two validation approaches and show the possibility of extension to the general weapon systems. From the experimental study, we show that the CSP recommendation system can be deployed for navy and air forces.

Keywords: Concurrent spare parts; Logistic support; Modelling and simulation; OASIS

1. INTRODUCTION

As the advanced technologies are applied to the weapon systems, the importance of the initial operational capability (IOC) has been getting more and more important for modern weapons acquired by any forces (army, navy and air force). Cutting-edge systems such as air fighters, destroyers, and submarines are being equipped with the complex systems. A failure in a part can affect the system-wide performance. To ensure the operability of these complex weapon systems, the repair parts must be supplied at the same time of the deployment. The systemic design approach can be employed on the software basis to increase interoperability, functionality and performance at the design stage to maintain the system performance while the functionality of a system is downgraded¹. In this paper, authors address concurrent spare parts (CSP) prediction based on the end items in the shop replaceable units (SRUs) and line replaceable units (LRUs) level. We assume that the SRUs and LRUs have designed and manufactured including software capability already.

The concurrent spare parts (CSP) are the quantity of spare parts that can facilitate the operability of the weapon systems without additional supply being needed during a certain period of IOC by acquisition organisations². CSP are critical to operation and maintenance of the weapon systems during initial fielding. However, the computation of the recommending optimal CSP is a difficult problem, since the advanced weapon

systems are very complicated. Also, the faults pattern cannot be guaranteed according to the new systems operation.

As reported in the paper of Boylan³, *et al.* the demand for CSP occurs infrequently, has low average volumes, and shows highly variable volumes, which is called non-normal demand. Because of the characteristics of the military weapon systems, the researchers have studied the item-level comparison in the South Korean navy, using the hierarchical forecasting, the combinatorial forecasting, the top-down forecasting, and the direct forecasting⁴. Moon⁵, *et al.* proposed that the logistic regression model, which could increase prediction accuracy while reduce errors and inventory costs.

CSP computation can be categorised as having two main purposes: (i) demand-based sparing (DBS), which has been characterised as a day of supply and (ii) readiness-based sparing (RBS), which focuses on maximising operational availability (A_o) within budgetary constraints⁶. For sustaining the operational availability of weapon systems, the Ministry of National Defense (MND) and Defense Acquisition Program Administration (DAPA) in South Korea established regulations on CSP acquisition^{7,8}. The regulation from the MND and DAPA mandated that all organisations pursuing acquisition must procure CSP within a given budgetary scale (fixed monetary limit).

To make the accuracy of the CSP prediction high enough, criteria should be considered, such as mean time between failures (MTBF), A_o and cost ceiling. In 1996, the Republic of Korean military (ROKM) developed the CSP generation software, named optimal allocation of spares for initial

supports (OASIS). The OASIS is basically constructed on the RBS concept. DAPA had upgraded the CSP software to OASIS 2.0, yielding three independent versions for army, navy and air force in ROKM in 2007. Further, DAPA released the OASIS 3.0 only for the Korean navy (OASIS 3.0/N) in 2015. The OASIS 3.0/N is proven to be more effective than OASIS 2.0/N in terms of recommending the optimal CSP list. However, since there is a difference in environment between the Republic of Korea Navy (ROKN) and the Republic of Korea Air Force (ROKAF), the OASIS 3.0 could not have been deployed into ROKAF. To deploy the enhanced OASIS version, the demand for validating OASIS has increased recently. In this paper, author explore the expandability of OASIS 3.0 to various military forces under different combat environments. We conduct the experiments for validating the feasibility and the functional extension of the OASIS 3.0/N to ROKAF with the real world data.

Authors presented two validation approaches in this paper. The two approaches is achieved step-by-step wise for higher CSP prediction. The first step is to facilitate the OASIS 2.0 and 3.0 to validate the performance without the field operation data from the air force. The second stage is consisted of the three phases. Firstly, we conduct the CSP prediction with only engineering and design data. After that, we combine the field data and modify the engineering and design parameters (MTBF, MTTR, and so on). In the last stage, we verify the prediction performance in terms of A_o and budget constraints by using RAM (Reliability, Availability and Maintainability) validation and verification simulations (briefly, called RAMVV). At the end of our work, we noticed that the prediction accuracy of CSP up to 23.1 per cent and 7.16 per cent higher in terms of budget constraint and operational availability (A_o) constraint.

Our contributions are as follows: (i) we investigate the effectiveness of OASIS 3.0 with the field operation data in a ROKAF aircraft (A-X). (ii) Through our case study, we validate that the improvement of the OASIS 3.0/N shows its general strength for both an air force and a navy operation environment, using RAMVV. (iii) Furthermore, we show that that our approach can be applied to any weapon systems.

2. CSP GENERATION MODEL OF ROKM

The main purpose of this paper is providing a case (field) study on CSP recommender systems to contribute the research and the field operation rather than creating novel algorithms or approaches. Since the environment of developing new weapon systems vary considerably with for each country, it is hard to define a rigid and fixed approach. However, the main goal of CSP recommendation is common, ‘minimising budget & maximise operational availability’. On the other hand, the case studies for CSP generation are limited since there is no general rule of CSP over the world (it depends on government’s policies or military requirements in a country. The current OASIS 3.0/N is designed and structured on the variances-multi-echelon for recoverable item control (VARI-METRIC)⁸, since VARI-METRIC uses the negative binomial distribution (NBD) to represent the occurrence of system failures for a certain time of period¹⁰. However, the newly developed weapon systems have the critical limitations.

Since ROKM developed the systems based on their

technologies, they did not have a failure history to use for estimating the quantity of spare parts after IOC; the conditions of operational environment and mission profiles are too unique to cover the parts sparing. ROKM employed overseas handbooks and data sheets such as MIL-HDBK-217F¹¹, non-electronic parts reliability data (NPRD)¹², and Offshore Reliability Data Handbook (OREDA)¹³. To overcome these flaws, DAPA had developed the latest version, i.e., OASIS 3.0/N in December 2014.

OASIS 3.0/N was designed with the improved functions by utilising three serial estimation processes, summarised in Table 1, which can combine the historical data of ROKM and given information from outside Korea¹¹⁻¹³. The conceptual details are depicted in Fig. 1. For a conceptual summary, OASIS 3.0/N adopted the combination of theoretical failure rate (upper left in Fig. 1) and observed data (upper right in Fig. 1) during the operation of weapon systems with the weighted average¹⁰. OASIS 3.0 performs two level searches for yielding CSP recommendations. First, it finds the number of LRUs and SRUs using a Lagrange multiplier to find an optimal solution under two constraints: minimising CSP cost and maximising operational availability. At the second stage, it facilitates a genetic algorithm¹⁴ for adjusting the inventory levels. However, this study shows the strong possibility of naval systems. We expand the OASIS 3.0/N to the general case onto the air force systems in this paper.

Table 1. The three serial estimation processes.

Process	Description
Process 1 (bottom-up)	Modelling the failure rate of systems using MIL-HDBK-217F ¹⁰
Process 2 (bottom-up)	Combining the failure rate with the ROKM’s historical failure rate
Process 3 (top-down)	Allocating the combined failure rate into subsystems (parts) based on their proportions to the failure rate of the higher parts

3. ISSUES ARISING OUT OF OASIS 3.0 DEPLOYMENT

There are variants of the definition on A_o , since it implies the capability of operating time given a specified period (for example, week, month, or year) with the recovery from maintenance activities. A_o , can be defined differently by using only system down time and mission time¹⁶ as stated in Eqn. (1).

$$A_o = 1 - \frac{T_d}{T_m} \tag{1}$$

where T_d and T_m represent the system down time and the total mission time, respectively.

The common definition of A_o , during the development stage can be defined as follows¹⁷:

$$A_o = 1 - \frac{MTTR+MLDT}{MTBF+MTTR+MLDT} = \frac{MTBF}{MTBF+MTTR+MLDT} \tag{2}$$

where MTBF, MTTR, and MLDT are mean time between failure, mean time to repair, and mean logistic down time, respectively.

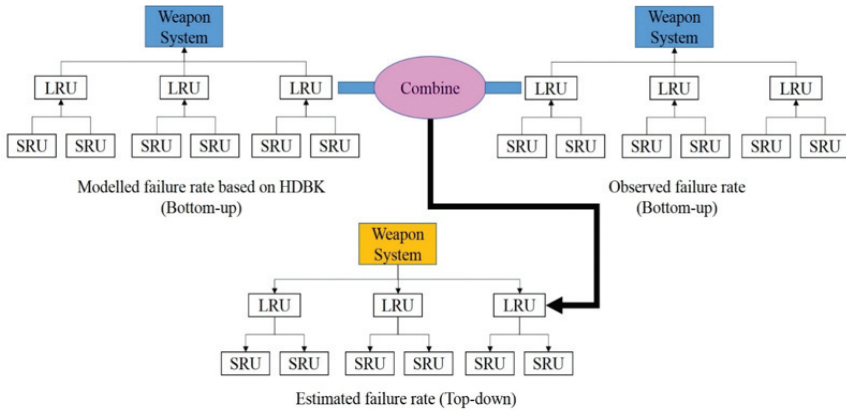

Figure 1. Failure-rate estimation process¹⁰.

Also, the availability can be expressed indifferent ways with more detailed information. For example, an A_o can be defined as Eqn.(3) as stated²:

$$A_o = \frac{MUT}{MUT+MDT} \tag{3}$$

$$= \frac{OT+ST+AT}{OT+ST+AT+TCM+TPM+TALDT}$$

where MUT, MDT, OT, ST, AT, TCM, TPM and TALDT stand for mean up time, mean down time, operation time, standby time, alert time, total corrective maintenance time, total preventive maintenance time, and total administrative & logistics delay time, respectively.

As seen in Eqns. (1) - (3), A_o is very sensitive to the occurrences of failures during missions and the time required to bring any weapon systems to normal status¹⁸. However, the recovery time (i.e., MTTR) from the number of failures depends on the supply condition (CSP status for each force). Warship missions in a navy force are intermittent, since once a warship leaves her harbor with CSP inside, there exists less chance for it to be re-supplied from its home base. Unlike ROKN, ROKAF has a supply center for each operation base, and the supply center can feed spare parts immediately with a small delay when maintenance is reported after a mission is finished. (Note that there is a ‘small’ delay time from a supply center to an operation point. However, ‘small’ means that the period is shorter than that of ROKN). An army may have a delay time for the maintenance, since soldiers or combat units are moving continuously around a campaign area. Therefore, in this paper we compare and observe the feasibilities and functional extensions between different military branches.

Since the latest version of OASIS 3.0/N was developed for the naval weapon systems, no one can be sure that it can be deployed for other forces (army and air forces). To overcome the uniqueness of a navy and an air force, the formula of A_o can be transformed into two types. First, we elaborate A_o on aircraft. Since the mission time, T_m in Eqn. (1) represents a mission period, we define the mission period as an annual calendar time. Note that one may define T_m as a month, a quarter, or half year (six months). However, the variation from the definition of the period does not decrease generality in A_o . The total down time, T_d in Eqn. (1), can be expressed as the sum of MTTR and MLDT in Eqn. (2). Also, we assume that T_m

includes OT, ST and AT in Eqn. (3); T_d contains TCM, TPM and TALDT in Eqn. (3). Combining the concepts of A_o (Eqn. (1), (2) and (3)) and using the T_m and T_d , we can restate Eqn. (1) for an air force as follows:

$$A_o = 1 - \frac{T_d}{T_m} = 1 - \frac{Mean\ Down\ Time}{Mean\ Up\ Time} \tag{4}$$

$$= 1 - \frac{MTTR+MLDT}{MTBF}$$

On the top of Eqn. (4), we also need to insert an additional term to complete the concept (A_o) in terms of the characteristics of an air force. Since any air force has a number of aircraft for each of their operation bases, aircraft do not operate at the same time, but execute the missions

with the required numbers only when they are requested to be deployed. Because of the idle time under no mission (stand by on ground), Eqn. (4) is inadequate for airborne weapon systems. Therefore, the MTBF in Eqn. (4) should be modified by reflecting idle time.

One way to handle the idle time is to consider the idle time as uptime (operational time), as suggested in¹⁶. Commonly, one can consider the operation period as a year. Annual operation hours (AOH) are calculated from total calendar hours (TCH). To adjust MTBF accordingly, the US navy introduced a K-factor. Let K' be the K-factor for aircraft. K' can be defined as the inverse of the annual utilisation rate ($K' = \frac{TCH}{AOH}$). Using K' , the MTBF can be adjusted as $MTBF \leftarrow MTBF \times K'$.

For instance, if AOH = 876 hours (36.5 days), then, $K' = \frac{365 \times 24}{876} = 10$. Since the operation hours are reduced by $\frac{1}{10}$, the stand-by hours are multiplied by 10, which is K' . Therefore, total mission time (T_m) can be adjusted using K' : $MTBF \leftarrow MTBF \times 10$. Finally, we obtain Eqn. (5).

$$A_o (aircraft) = 1 - \frac{MTTR+MLDT}{K' \times MTBF} \tag{5}$$

On the other hand, warships in a navy differ from the airborne weapon systems, since the naval ships operate without supplying on the sea after leaving the seaport¹⁶. Also it can be constructed another K-factor (K'') as Eqn.(6).

$$K'' = K' - \frac{MTTR+MLDT}{MTBF} \tag{6}$$

To understand K'' intuitively, we elaborate on Eqn.(6).

Using Eqn. (4), $\frac{MTTR+MLDT}{MTBF}$ can be restated as Eqn. (6) as shown by¹⁹.

$$\frac{MTTR+MLDT}{MTBF} = \frac{T_d}{T_m} \tag{7}$$

Also, AOH can be interpreted as T_m (or MTBF). Now, K'' be written as Eqn. (8)

$$K'' = \frac{TCH}{T_m} - \frac{T_d}{T_m} = \frac{TCH-T_d}{T_m} \tag{8}$$

The amount of downtime is reflected in K'' , so there is a

smaller impact of idle time than for K' . This implies that naval ships are imposed more penalty (i.e., $K'' = \frac{TCH-T_d}{T_m} < K' = \frac{THC}{T_m}$) because of longer operation periods than airborne systems (aircraft). Using Eqn. (2) and (6), A_o of naval ships can be written as

$$A_o(\text{warship}) = 1 - \frac{MTTR+MLDT}{K'' \times MTBF + MTTR + MLDT} \quad (9)$$

$$\frac{K'' \times MTBF}{K'' \times MTBF + MTTR + MLDT}$$

Using Eqn. (9), the performance of OASIS 3.0/N was reported¹⁵. In this paper we verify and validate the performance of OASIS 3.0/AF by simulation with the real world data provided by ROKAF logistic command. Note that our simulations differ from those of¹⁵, in that we designed double-step approaches to mirror the real-world operation.

4. VALIDATION APPROACH OF SYSTEM PERFORMANCE

The evaluation of the performance can be done with two criteria: the targeted availability and the budget constraint of a weapon system. Let the targeted A_o and budget constraint be A_o^c and B^c , respectively. In this paper we conduct experiments with both criteria in the following ways; (i) if we fix A_o^c , we compute the required budget to achieve A_o^c . (ii) when B^c is given, the system yields A_o using B^c , and vice versa.

Since there is no correct information or actual field data regarding A_o and B^c , we conduct an experimental study on the weapon system operations as follows. First, we generate random failures for each items. At this time, we need one assumption, that the random failures follow a probability distribution. Generally, a weapon system's reliability can be expressed as Eqn. (9)¹⁶.

$$R(t) = e^{-\lambda t} \quad (10)$$

where λ and t stand for failure rate and time, respectively. Since λ implies the inverse of MTBF, $\lambda = \frac{1}{MTBF}$ in Eqn. (10), we can restated it as Eqn. (11).

$$R(t) = e^{-\lambda / MTBF} \quad (11)$$

Therefore, using Eqn. (11), we generate the random failures following an exponential distribution in our experimental study. We tested the OASIS 2.0 and 3.0 with averaged values after running it 50 times, assuming the results follow the central limit theorem.

To validate the performance of OASIS 3.0 on weapon systems of an air force, we need to set up a validation approach, accordingly. With the given information such as MTBF, MTTR, turn-around-time (TAT), and so on, we construct the approach with two phases. We show the conceptual test process of the two phases in Fig. 2.

4.1 Performance of System only

This approach is designed for the evaluation of the performance between OASIS 2.0 and 3.0 when they are applied to air force systems. As stated before, we conduct experiments

with A_o^c and B^c , independently. Whenever we acquire the results of CSP information (required quantity for each part), we pass the results into the simulation tool. OASIS 2.0 and 3.0 need 25 and 27 identical input data, respectively.

4.2 Performance via Field Data

Even though the PSO approach can evaluate the prediction performance of OASIS 2.0 and 3.0, PSO does not reflect the field condition, since input criteria do not perfectly mirror the operation environment, i.e., the given information comes from engineering data during design phases. For example, MTBF can have longer or shorter values than were predicted during the design phase; the predicted MTBF is 100 h when a component was designed, but it can operate at more than its original value. On the other hand, a shorter time is possible between system failures. And in the same vein, MTTR and TAT will be varied.

To overcome unrealistic input data in real machine failures, we designed an additional phase called performance via field data (PFD). PFD tries to make our experimental study realistic in terms of MTBF. Since MTTR and TAT are controllable by operation units, and other input has fixed values, such as unit prices, the most critical one is MTBF among all input data. Also, MTBF is closely related to operation hours and A_o , as shown in Eqns. (5) and (9). Therefore, we collect, analyse, and modify MTBF using field operation data. After modifying the MTBF, we use the modified MTBF for the input of the PSO approach.

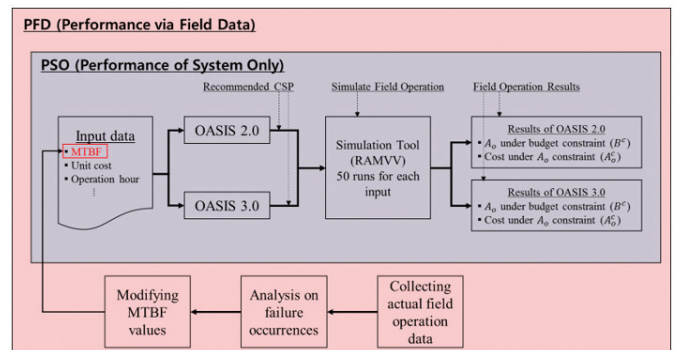

Figure 2. Conceptual test process of two phases (PSO and PFD).

5. EXPERIMENTAL RESULTS

5.1 Dataset Review

To conduct the experiments on the weapon systems of an air force, we gathered field operation data on an aircraft platform from ROKAF (a supersonic aircraft; we call it A-X hereinafter throughout this paper.) Because of the policy of the Korean government, we cannot show the exact name and detailed system specifications of the platform. A-X is selected, since we need an initial CSP list as well as field operation data in a platform. A-X was developed and completed its serial production in the 2010s. A-X consists of 627 parts in terms of the CSP list. The input data (parts information) of A-X is summarised in Table 2. Also, ROKAF has built up its operational experience after the completion of serial production.

Then, we select 25 A-Xs for our evaluation. Among them,

Table 2. Spare parts status on A-X

Part level	LRU*		SRU**		Total
Part type	Replaceable	Consumable	Replaceable	Consumable	
Quantity	225	163	153	86	627

* LRU: Line Replaceable Unit, **SRU: Shop Replaceable Unit, Note that the material for preventive maintenance (e.g., oil, battery, filter, lamp, etc.) is omitted in this table.

we assign data from 10 aircraft as the system for evaluating PSO. The rest (15 A-Xs) belong to PFD. The A-X aircraft have more than five years of experiences in field operations. We collect the parts of the consumption record during 3 years from ROKAF, since the CSP requires an initial 3 years from IOC according to the government policy. After gathering the data, we modify MTBF according to the definition of MTBF as shown in Eqn. (12)

$$MTBF = \frac{\text{Total Operation Hours}}{\text{The Number of Fault Occurrences}} \quad (12)$$

To differentiate MTBF between design phases and field operation data, let $MTBF_d$ and $MTBF_f$ be design phase MTBF and field operation MTBF, respectively. Some 96 items out of 627 parts are found during the field operation, and 93 items show the difference between $MTBF_d$ and $MTBF_f$. $MTBF_f$ is greater than $MTBF_d$ in 56 parts (60.2% of parts), which implies that the actual operation hours are longer than calculated when they were designed, and 37 parts (39.8 % of parts) are lower for $MTBF_f$ than for $MTBF_d$. We plot the distribution of the difference between $MTBF_f$ and $MTBF_d$ in Fig. 3, which shows there exist huge differences; for example, part #16 shows 145,892 h shorter for MTBF than was expected during its design phases. The observation on this difference between $MTBF_f$ and $MTBF_d$ is outside the scope of this paper. We leave this issue (why the large variance exists) for the future work.

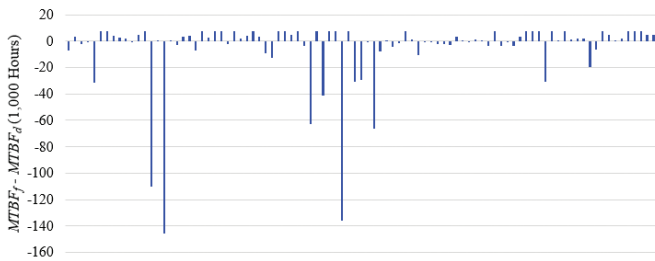

Figure 3. The distribution of MTBF Differences ($MTBF_f - MTBF_d$).

Table 3. Experimental data (field operation records) summary

	Descriptions	Remark
Platform type	A-X	Target aircraft in this paper.
# of aircraft	15	The record of parts consumption during operation
# of LRU	91	89 LRUs show different MTBF
# of SRU	5	4 SRUs show different MTBF

Note: We set B^c as 0.04 (4% of total acquisition cost); A_o^c is decided by the operational requirement from ROKAF (in this paper, we set $A_o^c = 0.91$)

5.2 Evaluation of PSO

We acquire the engineering data as an input dataset (part name, MTBF, MTTR, annual operation hours : AOH, unit cost, etc., from the aircraft manufacturer). Each version of OASIS received the input dataset. After computing the CSP solution for 10 A-Xs, we pass the CSP solutions into the simulation tool (RAMVV). Note that RAMVV was developed by the Korean Defense Agency for Technology and Quality (DTaQ), and is not released to the public yet (allowed for military use only). Finally, we gather the result for each criterion (A_o^c or B^c). The experimental results are shown in Figs. 4 and 5.

Performance under budget constraint. OASIS 2.0 and 3.0 generate 77.38% and 70.37% in terms of A_o , respectively. Before we have a verification of operational simulation, OASIS 2.0 shows 7.11% higher A_o . One may intuitively understand that OASIS 2.0 can achieve higher A_o using its CSP recommendation. However, when we check the results from operation simulation (RAMVV), the results are reversed. As shown in Figure 4, when we use the CSP recommendation from OASIS 3.0, the final A_o is 23.1% higher ($A_o = 73.87\%$) than for OASIS 2.0 ($A_o = 51.95\%$). The A_o of OASIS 2.0 becomes even lower after operation simulation (77.38% → 51.95%). In terms of verification, we can have more confidence in CSP recommendations after operation simulations, which indicates that OASIS 3.0 can provide CSP solutions closer to the conditions of field operations.

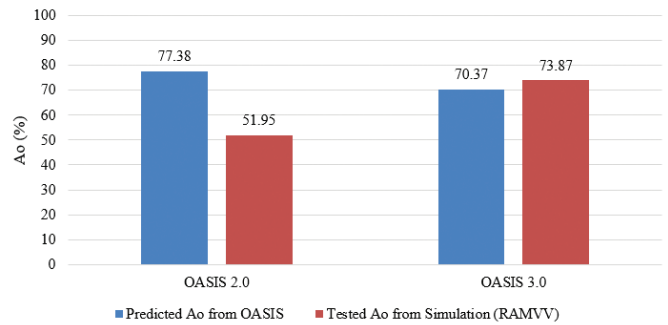

Figure 4. Results under Budget constraint (fixing $B_t=0.04$).

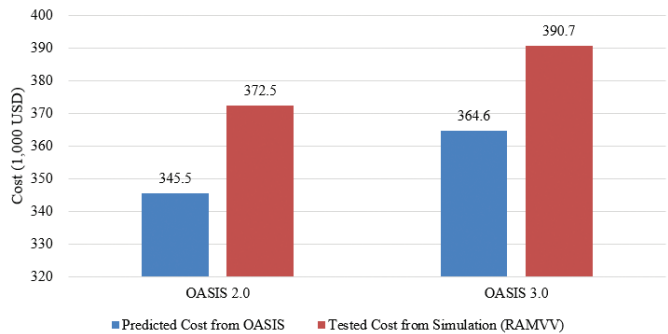

Figure 5. Results under Availability constraint ($A_o=0.91$). The original cost unit was Korean Won (KRW). Exchange rate was applied for USD in Feb. 13, 2017.

Performance under A_o constraint. Both OASIS 2.0 and 3.0 generate the CSP acquisition cost of \$345.5K and \$364.6K, respectively. OASIS 3.0 yields a \$19.1K higher cost for purchasing the CSP. Also, the two versions of OASIS show increasing patterns after operation simulations (OASIS 2.0 = +\$26.9K, OASIS 3.0 = +\$26.1K). Even though OASIS 3.0 recommends higher CSP acquisition costs, the increment of the cost is kept in almost the same rate. For more detail, OASIS 2.0 increases its operational cost by 7.81%; OASIS 3.0 increases up to 7.16%. OASIS 3.0 shows slightly better performance in terms of cost under the operation simulations.

5.3 Evaluation of PFD

We collected field operation data (15 A-Xs) from ROKAF to evaluate the effectiveness of the recommendation performance of OASIS 3.0. Using the field operation data, we modified the MTBF, which is one of the key inputs to OASIS 3.0. The experimental results with the modified MTBF are presented in Figs. 6 and 7. With a given MTBF, the predicted A_o via OASIS is similar (OASIS 2.0 = 49.65, 3.0 = 46.03; see Figure 6). We argue that this result came from the modification of MTBF according to the field operation data. However, when we look at the results of the operation simulation using OASIS 3.0, the improvement is 51.9% in terms of A_o .

On the other hand, the results for OASIS 2.0 show the decreased performance (-7.3%) after the operation simulations. Figure 7 shows the performance under the A_o constraint with the modified MTBF. Note that no differences are found

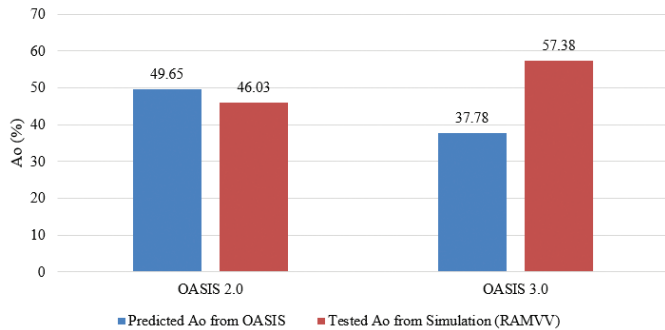

Figure 6. Results under Budget constraint (fixing $B^C = 0.04$) with modified MTBF using field data.

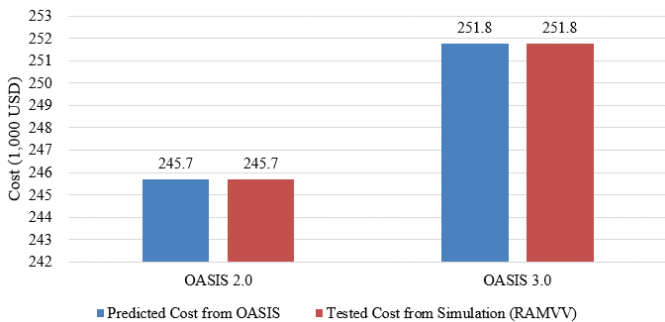

Figure 7. Results under Availability constraint ($A_o^C = 0.91$) with modified MTBF using field data. The original cost unit was Korean Won (KRW). Exchange rate was applied for USD in Feb. 13, 2017.

in terms of CSP acquisition cost. From the observations, we saw that correct MTBF values increase the system availability more than the budget constraint (B^C). The reason for this phenomenon, we conjecture, is that OASIS 3.0 was improved, in that it tries to search for optimal CSP using both LRUs and SRUs level of weapon systems.

6. DISCUSSION

6.1 Trade-off between Availability and Cost

The improved CSP software (OASIS 3.0) shows better prediction accuracy in terms of A_o than the previous version (OASIS 2.0). Since OASIS 3.0 searches SRUs, it can increase A_o . We argue that OASIS 3.0 can be applicable to airborne systems to find more efficient CSP levels under budgetary limitations. Throughout the PFD approach, we also confirmed that OASIS 3.0 performs better in a field operation environment.

However, the CSP cost from OASIS 3.0 is also increased, even though the increase rate is almost same as that of OASIS 2.0. As we can see, there is a trade-off between A_o and CSP cost. If we focus on achieving A_o , the cost for acquiring CSP will exceed given budget limitations, which leads to budget reduction. On the other hand, if we want a fixed budget on CSP, A_o is not satisfied by the operational goals, which results in sacrifice of A_o with allowable tolerance to military forces. This problem might be resolved via decision making processes or optimisation approaches. Decisions on the final CSP quantity are out of this paper’s scope. However, the availability and cost impact can be evaluated during the CSP computation to providing the user with helpful information. We leave this trade-off issue for our work.

6.2 Mirroring a Perfect Operational Environment

We validated the effectiveness of recommended CSP for airborne weapon systems via simulated field operation. Our approach can be applied to any type of complex systems when one suffers from lack of field operation data. Note that weapon systems need long lead time to be developed and field tested. Also, the information on weapon systems is not publically released. However, the generation of random failures could partially mirror the exact operation environment. This limitation can be overcome by data accumulation from various case studies. It is possible for the research community to model the realistic simulations to reflect real-world operations.

6.3 Continuous vs. Intermittent Systems

A remaining question is whether CSP software (OASIS 3.0) can cover all possible weapon systems. The taxonomy can be categorised into two classes (intermittent-use and continuous systems); “intermittent-use systems have long periods of standby or inactivity between users; continuous-use system are always in use during operations of their host platforms”¹⁸. Aircraft, warships, and fire-control radar can be a subset of the intermittent-use systems. The continuous-use systems are, for example, search radars, radio receivers, and so on. We performed an experimental study on naval and airborne weapon systems which belong to the intermittent-use systems.

However, is it still valid if OASIS 3.0 is applied to a continuous system with our validation approach (PSO and PFD)? The A_o of continuous-use systems is obviously simpler than that of intermittent-use systems, which is exactly the same form of Eqn. (3) or (4), since one does not need to adjust the idle time of weapon systems. Therefore, we argue that the simplicity of the continuous-use systems can apply to the multi-echelon search approach (OASIS 3.0) without loss of generality.

6.4 Expandability to General Weapon Systems

Can our approach be applied to ground weapon systems (army) or to all kinds of weapon systems? Until now, we have conducted our research based on the navy and air force. The uncovered area is mainly ground systems (army). Representative army systems are tanks, armored vehicles, self-propelled artilleries, and so on. The ground systems are very similar to airborne systems, since the ground systems cannot run over a day, because of the human operators' need to repose or recharge, and so are like airborne systems in utilising the K' factor. To confirm the effectiveness for a ground system, case studies are needed using various army platforms.

One may argue that the possibility of deployment is opaque when we want to analyse simple systems, such as pistols, rifles, ammunitions (small arms). However, a critical point of CSP recommendations is the increasing complexity of systems-of-systems. The initial spare parts aspect of the simple systems does not need any assistance from automated and complex software tools (such as OASIS 2.0 and 3.0).

7. CONCLUSIONS

On top of the effort to develop CSP recommendation software (OASIS 3.0), we extended the validity of use from only naval systems to airborne weapons (air force) via using real-world weapon systems (A-Xs). We compared the CSP prediction performance in OASIS 2.0 and 3.0 under two criteria (A_o^C and B^C). OASIS 3.0 shows better accuracy than 2.0 in terms of A_o . To confirm the performance, we conducted randomised simulations with CSP recommendations.

Even further, to see the more realistic field simulation, we collected field operation data from the logistics command. From the gathered information, we modified the MTBF, one of the main inputs to the OASIS system. From the two validation approaches, we confirmed that OASIS 3.0 has better prediction performance. Furthermore, we elaborated the expandability to any weapon systems with current CSP recommendation systems.

REFERENCES

- Rao, D; Karri, M.S. & Sarma, M. An architecture based approach to assess the reliability and performance of naval platforms. *J. Battlefield Technol.*, 2015, **18**(3), 31-40.
- Choi, K. & Lee, S. Integrated logistic support handbook. *In* Defense Administration Program Acquisition. Korea MoD Publication Depot, Seoul, Korea, 2015. (Korean).
- Boylan, J.E.; Syntetos, A.A. & Kara Kostas, G. Classification for forecasting and stock control: A case study. *J. Operational Res. Soc.*, 2008, **59**(4), 473-81.
doi: 10.1057/palgrave.jor
- Moon, S.; Hicks, C. & Simpson, A. The development of a hierarchical forecasting method for predicting spare parts demand in the South Korean Navy-A case study. *Int. J. Production Eco.*, 2012, **140**(2), 794-802.
doi: 10.1016/j.ijpe.2012.02.012
- Moon, S.; Simpson, A. & Hicks, C. The development of a classification model for predicting the performance of forecasting methods for naval spare parts demand. *Int. J. Production Eco.*, 2013, **143**(2), 449-454.
doi: 10.1016/j.ijpe.2012.02.016
- Spignesi, N.A. Implementing readiness based sparing in the United States Marine Corps by analyzing the United States Army's implementation process. Naval Postgraduate School, California, 1998. (Master Thesis) <http://www.dtic.mil/dtic/tr/fulltext/u2/a358984.pdf> (Accessed on 25 March 2017).
- Ministry of Defense. Defense Power Development Operation Regulation. Ed 16th. Seoul, Korea, 2016. (Korean Government Regulation)
- Defense Administration Program Acquisition. Defense Program Management Regulation (393th edition), Seoul, Korea, 2017. (Korean Government Regulation)
- Sherbrook, C.C. Optimal inventory modeling of systems: Multi-echelon techniques. Springer Science & Business Media, Boston, USA, 2006.
- Moon, S. The Improvement of the model estimating demand for concurrent spare parts. *In* International Military Science & Technology Fair, Seoul, Korea, 2014.
- US DoD. US MIL-HDBK-217 Reliability Prediction of electronics Equipment, Version F, Notice 2. USA, 1995.
- RIAC. No electronic Parts Reliability Data NPRD-2016. Quanterion Solutions Incorporated, NY, USA, 2016.
- ORDEA. Offshore and Onshore Reliability Data (6th edition). SINTEF and NTNU, 2015.
- Syswerda, G. Uniform crossover in genetic algorithms. *In* Proceedings of the 3rd International Conference on Genetic Algorithms, Morgan Kaufmann Publishers Inc., San Francisco, CA, USA, 1989, pp. 2-9.
- Seongmin, M. & Ui, J.K. The development of a concurrent spare-parts optimisation model for weapon systems in the South Korean Military Forces. *Interfaces*, 2017, **47**(2), 122-36.
doi: 10.1287/inte.2016.0869
- Macheret, Y.; Koehn, P. & Sparrow, D. Improving reliability and operational availability of military systems. *In* Aerospace Conference, IEEE, Big Sky, MT, USA, 2005, pp. 3948-57.
doi: 10.1109/AERO.2005.1559700
- Joel Manary, A.P. & Weinstein, L. Operational availability handbook: A practical guide for military

systems, sub-systems and equipment. US Department of the Navy, Washington D.C., USA, 2003. <https://doni.documentservices.dla.mil/Directives/03000%20Naval%20Operations%20and%20Readiness/03-00%20General%20Operations%20and%20Readiness%20Support/3000.12A.pdf> (Accessed on 24 March 2017).

18. Crow L. Methods for reducing the cost to maintain a fleet of repairable systems. *In* Reliability and Maintainability Symposium, IEEE, Tempa, FL, USA, 2003, pp. 392-99.
doi: 10.1109/RAMS.2003.1182021
19. Conway, D.H., & Poh, A.R. Calculating operational availability of intermittent use ship systems. *Naval Engineers J.*, 1989, **101**(3), 54-60.
doi: 10.1111/j.1559-3584.1989.tb02186.x

ACKNOWLEDGEMENTS

This work was supported by the Ajou University research fund and Basic Science Research Program through the National Research Foundation of Korea (NRF) funded by the Ministry of Education (2017R1D1A1B03035557).

CONTRIBUTORS

Dr Gisoep Noh obtained his PhD (Electrical and Computer Engineering) from Seoul National University. He is currently working as an assistant professor in Division of Software Convergence, Cheongju University. He has about 14 journal papers and 15 conference papers. His research areas includes: Computer networks, security, recommender systems, optimality in military logistics, social network analysis. Contribution in the current study, he has formulated main research ideas, conducted all simulations, analysed the results, and contributed in the manuscript preparation.

Dr Hayoung Oh obtained her PhD (Electrical and Computer Engineering) from Seoul National University. Presently, she is working as an assistant professor in DASAN College, Ajou University. She has more than 20 journal papers. Her research areas includes: analysis on military weapon systems, computer networks, computer security, social network analysis, and network coding. Contribution in the current study, she has provided overall guidance in the simulation and analysis. She has prepared the final manuscript and conducted the final checking for the integrity of this study.