

## Design and Development of Power Management System of Unmanned Underwater Platform for Defence Application

Arun Kumar\* and L. Anjaneyulu#

\*Advanced Systems Laboratory, Hyderabad, India

#Department of Electronics & Communication, National Institute of Technology, Warangal, India

\*E-mail: arunkumar1959@rediffmail.com

### ABSTRACT

Development of underwater weapon systems for defence application are carried out on unmanned underwater platform. Extensive testing and measurement of physical parameters are carried out during development phase trials. After several trials, system is qualified and installed on the actual platform. Mostly battery bank is used to power the unmanned platform. Design and development of power management system is an important issue of underwater platform to increase the underwater time of the platform. During development trials some additional equipments are also included for which power requirement was not considered during design of battery bank. This also becomes an issue to manage the power requirement of additional equipment beyond the design capability of the battery bank. Unmanned submersible platforms at a depth of 50 m to 70 m are used during development of underwater missile. Platform houses the missile to be tested, equipment required for missile launch and control of the platform. A power management system (PMS) with redundancy and fault tolerant features achieving reliability figure of 99 per cent has been designed, developed and tested successfully for underwater phase of missile launch. The system allows remote operation of individual or group of equipment, current monitoring, and isolation of faulty equipment. Power requirement for additional equipment on platform is also included in PMS without affecting the reliability of the system. Power control of equipment on requirement basis to save battery power, to increase underwater time of platform and to manage additional power requirement beyond the designed capacity of the battery bank is described in detail.

**Keywords:** Remote station; Underwater platform; Network management system; Power management system

### NOMENCLATURE

RS	Remote station
NMS	Network management system
PMS	Power management system
LIS	Lighting and illumination system
LCS	Launch control system
VIS	Video instrumentation system
RCDAS	Remote controlled data acquisition system
DCS	Data communication system
UPS	Uninterrupted power supply
RS-I	Remote station I
RS-II	Remote station II
RS-III	Remote station III
NWS	Network switch
RBD	Reliability block diagrams
OLTE	Optical line terminal equipment
MTBF	Mean time between failure
GUI	Graphic user interface
COTS	Commercially of the shelf

### 1. INTRODUCTION

The underwater missiles are developed for submarines. Submarines will have propulsion system that powers the equipment onboard submarine required for missile launch activities. When missile is not proven launching from submarine may cause damage to submarine in case of mishap. The underwater platform used for missile launch during development phase, will not have propulsion system and it is towed in the high sea to a location designated as launch site. The missile on the launcher is positioned in a container inside a canister at the centre of platform called super structure area, designed to withstand the load of missile and thrust during the launch. The total time required to conduct a launch is approximately three hours including the platform lowering and surfacing time. The platform will have battery bank to power the equipment when platform is submersed. Most of the equipment work on DC power and wherever AC power for COTS item is required, inverters are used to provide AC power. All equipment are located in pressure hull of the platform. The designed power of battery bank is not discussed in this paper and PMS is designed only to control power allocated for instrumentation load of 4 KW.

In addition to underwater platform there are two floating platforms, one is ship RS-I, the main control centre, and missile launch activities are carried out from this ship. Another floating platform called Mouring Buoy RS-II, is emergency station to be used during link failure between RS-I and RS-III. The schematic of power management system is as shown in Fig. 1. The distance between RS-III and RS-I is approximately 5000 m. The distance between RS-III and RS-II is approximately 300 m. The deployment length of cable is controlled by mechanical winching system on RS-I and RS-II.

During the launch, if trial is delayed due to any reason for a significant time, battery power will be consumed and platform has to resurface for charging the battery bank. To avoid, such situation a PMS is required to control power of equipment on requirement basis. PMS helps to manage the battery charged condition for longer duration and platform need not resurface for charging. The challenge is to save available power for longer duration or charge the battery in underwater itself to increase the underwater time of platform and complete the mission.

**2. LITERATURE SURVEY**

Available literature shows that underwater missiles during development phase are launched either from submarine or a special towed underwater unmanned platform designed for this purpose. Trident missiles of America are launched from a submarine<sup>1</sup>. Submarines will have propulsion systems and uses lead acid battery as an emergency source of power<sup>2</sup>. Towed under platform<sup>3</sup> is designed for launching of missile

during development phase. Battery bank of platform is designed to meet the total power requirement during launch activities including platform operation<sup>4</sup>. In case of missile launch, details are not available for charging on-board battery when unmanned platform is underwater. Submersible, semi-submersible and floating platforms are also used for study of sea bed, benthos, underwater inspection of objects and for other underwater studies and oil exploration. There are several methods for charging the batteries like using inductive coupling to recharge a lithium – ion battery pack<sup>5</sup>, Generation of electricity by rotating a turbine by sea waves at a particular depth<sup>6</sup>. US Navy is working on breakthrough technology and methods to recharge unmanned underwater vehicles using wireless technology<sup>7</sup> which will extend underwater time to months instead of hours. Since the launch activities of missile is required to be completed within stipulated time, the charging of on-board battery should be fast, so it is preferred to charge battery bank in conventional way by surfacing the platform though, specially designed underwater cables and connectors are available to charge the battery while platform is underwater. The platform is designed for required depth with two pressure hulls<sup>8</sup>. One pressure hull is used to locate equipment required for controlling the platform and other hull is used to locate equipment for launching the missile. The battery of platform is designed to provide 4 KW isolated power to the instrumentation load for a duration of 4 h<sup>9,10</sup>.

**3. SYSTEM DESCRIPTION**

While lowering the underwater platform at required

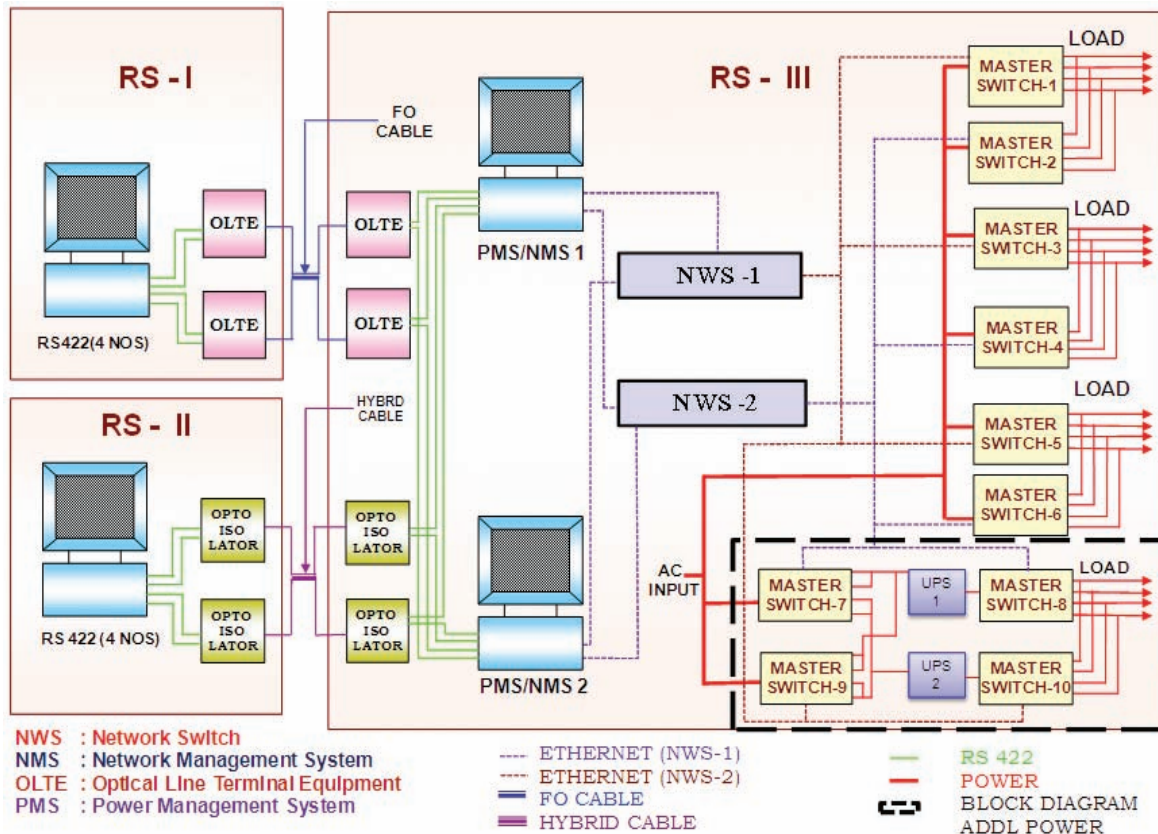

Figure 1. Power management system (PMS) and additional power requirement for underwater platform.

depth, it is necessary to establish communication link to RS-III from both the Remote Stations RS-I & RS-II. The connectivity of RS-III to RS-I is through fibre optic cable and to RS-II is through copper cable. To establish communication link, it is required that few equipment on RS-III must be switched on before lowering the platform in water and should not be operated by PMS. Only power of RCDAS, VIS, LCS, and LIS is controlled by PMS. The power requirement of RS-III may be listed under three categories.

- Continuous power requirement, not to be operated by PMS.
- Power controlled by PMS on requirement basis.
- Power controlled by PMS for a shorter duration during launch and cannot be supported by on-board battery on full load.

PMS is a PC based system also serves as NMS. It can be controlled by RS-I or RS-II through RS-422 interface. Master switch is standalone intelligent controllable power distribution switch with 8 power outlets and one inlet. Maximum of eight loads (10A) can be connected. The main feature of master switch is the independent control of outlets and inlet<sup>11</sup>. There are 10 master switches used and interfaced with PMS/NMS through network switch<sup>12</sup>. UPS batteries provide power to LIS by disconnecting input power of UPS for underwater lighting & illumination system during trial on a cloudy day. Network switch is used for connecting all equipment in the network where power control is needed.

The input of equipment is powered by two master switches in parallel to ensure redundancy and to avoid single point failure. All controls are through GUI and it also displays the current drawn by individual equipment. PMS is also required to provide additional power for lighting and illumination system not planned earlier. To meet this requirement two 1.4 KVA UPS<sup>13</sup> is planned as shown in Fig. 1. Future requirement of additional power can also be met by introducing UPS and master switches in the PMS. The battery backup time of UPS system is used to meet additional power requirement by disconnecting inlet of master switch, powering the UPS. Two UPS have been used to avoid single point failure due to inverter of UPS<sup>14</sup>. The all PMS related equipment are mounted in a 19 inches rack conforming to IP 54 of IEC standard<sup>15</sup>.

The total power requirement projected for a typical launch activities is as shown in Fig. 2. PMS can be designed by listing the power supply requirement of equipment, redundancy, operational requirement and the sequence of operation. All power requirement should be specified and communicated to ensure adequate battery bank capacity during design phase itself. Extra power budget may be planned for future requirement.

### 3.1 Testing

After implementation of design, PMS is tested for functional test, integrated test, power consumption cycle and failure mode.

Individual system is switched on by PMS and functional tests are carried out. During functional test LIS is tested in normal way along with VIS as total power demand is well below 4KW. Then all systems are switched on one by one according to sequence of operation and tested individually. Then all systems are tested in integrated mode. Power demand in integrated mode is more than 4 KW, LIS is operated by battery of UPS system. A typical power requirement and power consumption cycle is as shown in Fig. 3.

Finally the PMS is tested for failure mode that includes NMS/PMS, network switch, master switch, inlet and outlet of master switch and the UPS. Functional tests are carried out with redundant systems and vice versa.

### 3.2 Enhancement of Battery Charged Condition Time

Designed capacity of battery is 4 KW for 4 h. The total power available with battery for launch activities is 16 KWH. It takes approximately three hours to launch a missile. Let us assume that the platform is underwater and even after 140 minutes test could not be conducted due to some technical problem and it might take another 60 min to resolve the technical issue.

Without PMS system the battery will have only 3.23 KWH which is not adequate even for an hour of operation and it will be mandatory to bring the platform on the surface for charging the battery bank. With the help of PMS, the charged condition of battery has been extended and underwater platform need not

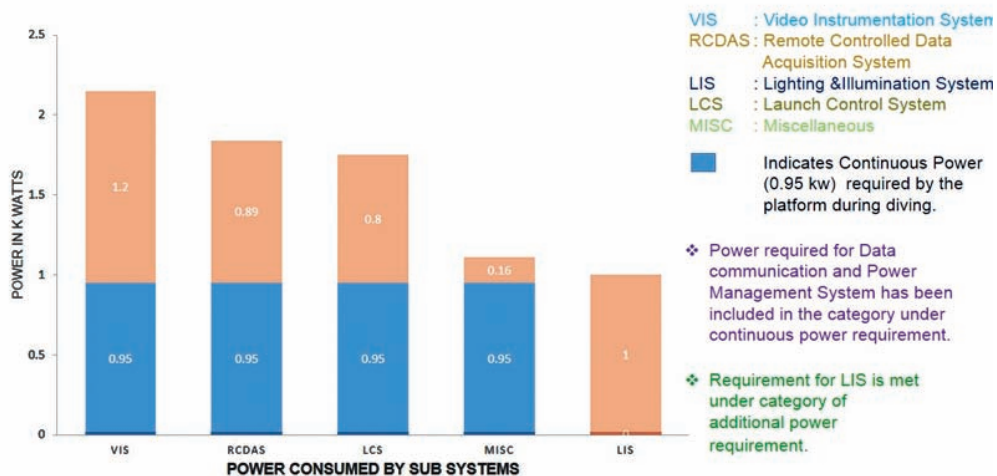

Figure 2. Power requirement managed by PMS.

**Table 1. Charged condition of battery with and without PMS**

System	Required power (KW)	Without PMS		With PMS	
		Time (min)	Power consumed (KWH)	Time (min)	Power consumed (KWH)
VIS	1.2	200	3.99	30	0.6
RCDAS	0.89	200	2.96	40	0.59
LCS	0.8	200	2.66	55	0.73
(PMS+DCS)	0.95	200	3.16	200	3.16
Total power consumed			12.77		5.24
Available power with the battery			3.23		10.32

surface for charging the battery bank. It is very clear from the Table 1 that by using PMS the charged condition of battery can be extended for a longer duration, thus increasing the underwater time of the platform.

**4. RELIABILITY PREDICTION**

Reliability prediction of PMS with additional power requirement is also carried out. RS-III has connectivity with two remote stations RS-I and RS-II as mentioned earlier. In case one link fails the other link will take care of the operation of the system. Therefore to increase the reliability and availability of the complete power management system the redundancy features have been introduced for all the subsystems. This will increase the system’s reliability. Redundancy in subsystems has increased the fault tolerance in the operation of power management system. The complete system is the combination of series-parallel configuration. This configuration will avoid single point failure in the operation of system. Reliability block diagrams (RBDs) method for predicting the reliability of PMS is used. RBD is a graphical representation of, how the subsystems of a system are reliability- wise connected. Each block in RBD represents a subsystem of the overall system.

Following are the details of the life distribution data of reliability models and its exponential distribution, for each sub systems required for RBDs to predict the reliability of the PMS.

- RS-I & II : MTBF: 30000 h
- OLTE: MTBF: 122640 h
- Opto-isolator: MTBF: 37037037 h
- PMS-I & II: MTBF: 30000 h
- NWS-I & II: MTBF: 100000 h
- Master switch: MTBF: 4901960 h
- UPS1 & 2: MTBF: 475000 h

The above values were provided as input to reliability block diagram and system reliability was calculated. The value is given below.

Reliability @ 1000 h = 99.79 per cent

Reliability @ 2000 h = 99.12 per cent

The reliability block diagram of power management system is as shown in Fig. 4.

It may be noted that by adding master switch and UPS combination in parallel will not affect the redundancy and reliability of the system.

**5. CONCLUSION**

The PMS discussed in the paper has been designed, installed and used successfully for powering underwater platform. This system was able to manage the charged condition of the battery for longer duration meeting the requirement. Use of additional equipment not in power budget was also used. The PMS is fully redundant and any single point failure will not jeopardise the test. The concept of power management is not only applicable for underwater platform but can also be extended to land based system, remote station, like hazardous area and other place where safety is important. It is possible to isolate the faulty equipment quickly. It is easy to monitor the power statistics like the current drawn by individual equipment with GUI.

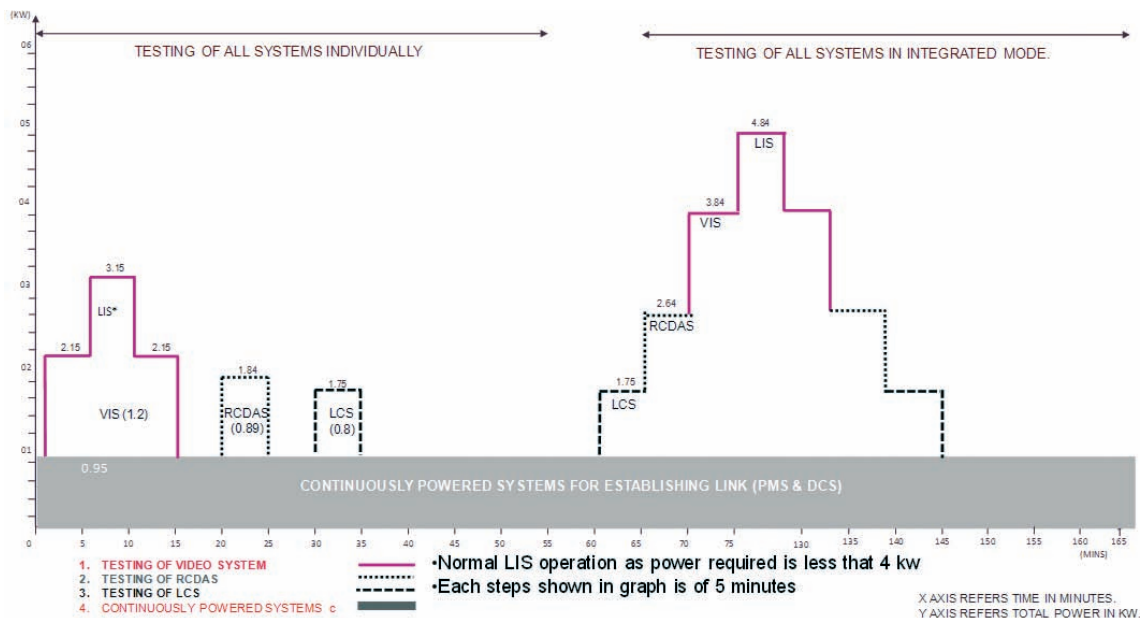

**Figure 3. Power consumption cycle.**

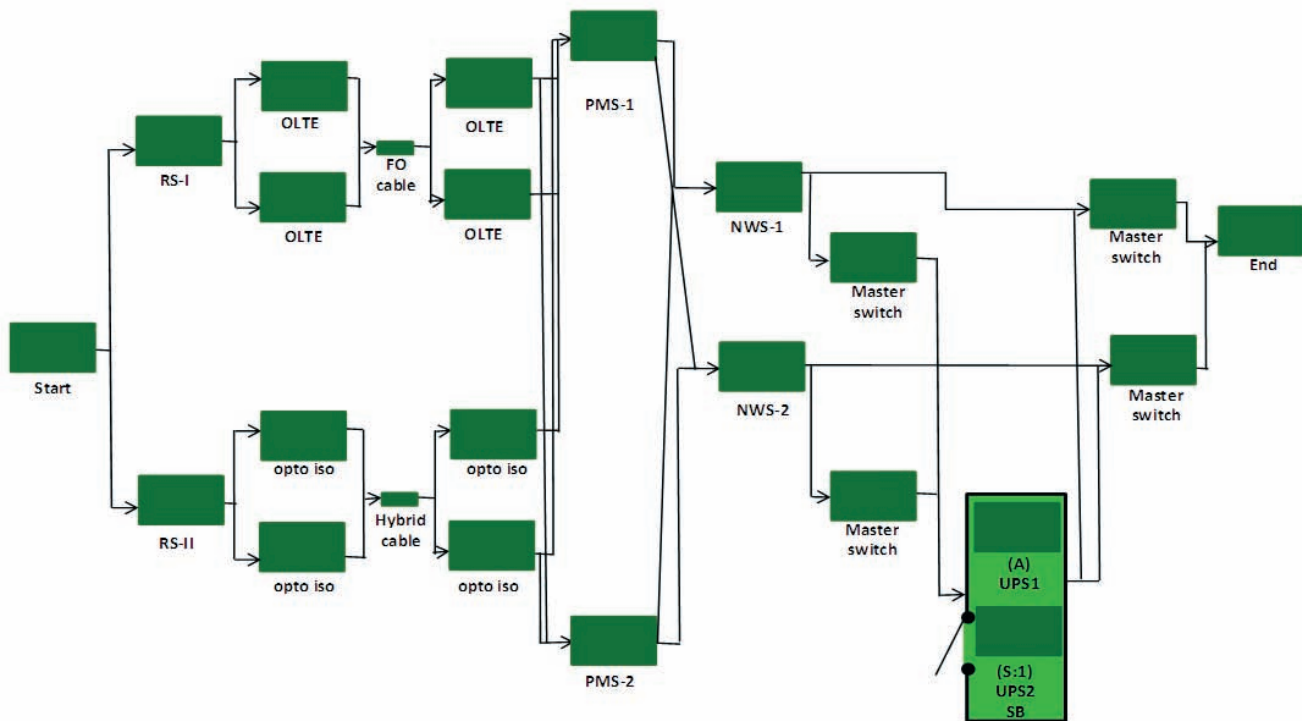

Figure 4. Reliability block diagram.

REFERENCES

1. Gilbert Buckman, R. & Vetter, Jerome R. Test range systems development and testing. *Johns Hopkins APL Tech. Dig.*, 1998, **19**(4), 398-401.
2. Lakeman, J.B. & Browning, D. The role of fuel cells in the supply of silent power for operations in seaside waters. Physical Sciences Department & QinetiQ Centre for Marine Technology UK, Acc. No. ADA428713. April 2004.
3. Wang, W.H; Chen X.Q.; Marburg, A.; Chase, J.G. & Hann, C.E. A Low-Cost unmanned underwater vehicle prototype for shallow water task. *In Proceeding of IEEE/ASME International Mechatronic and Embedded Systems and Applications 2008*, IEEE/ASME, Beijing, China, 2008. doi: 10.1109/mesa.2008.4735649
4. Bradley, Albert M.; Feezor, Micheal D.; Hanumant Singh & Yater Sorrell, F. Power systems for autonomous underwater vehicles. *IEEE J. Oceanic Eng.*, 2001, **26**(4) 526-538. doi: 10.1109/48.972089
5. McGinnis, Tim; Henze, Christopher P. & Conroy, Karl. Inductive power system for autonomous underwater vehicles. *In Proceeding of OCEANS 2007, MTS/IEEE, Vancouver, BC, 2007.* doi: 10.1109/oceans.2007.4449219
6. Martinzes, Manuel Torres. Power station on a submerged floating platform. US patent US20100264658 A1, 21 October 2010.
7. David Russell Schilling. New undersea wireless energy transfer charges underwater vehicle batteries. August 30, 2015. [www.industrytap.com/new-undersea-wireless-energy-transfer-charges-underwater-vehicle-batteries/31032](http://www.industrytap.com/new-undersea-wireless-energy-transfer-charges-underwater-vehicle-batteries/31032) [Accessed on 2 July 2016].
8. Parthasarathy, K.N.; McGrath, B.E.; Frostbutter, D.A. & Wozniak, J.J. Development of a towed underwater launch platform. Acc. No. ADA318766. 1996.
9. Zhang, Ying; Kurtoglu, Tolgo; Tumer, Irem Y. & O' Halloran, Bryan. System-level reliability analysis for conceptual design of electrical power systems. *In Proceeding of Conference on Systems Engineering Research (CSER) 2011*, PARC, Los Angeles, CA, 2011.
10. Hasvold, Oisten; Stoorkersen, Nils J.; Forseth, Sissel & Lian, Torliel. Power sources for autonomous underwater vehicles. *J. Power Sources*, 2006, **162**(2), 935-942. doi: 10.1016/j.jpowsour.2005.07.021
11. APC 1.5 kva UPS, website and technical manual. [www.apc.com/resource/include/techspec-index.cfm?base-sku=su1400i](http://www.apc.com/resource/include/techspec-index.cfm?base-sku=su1400i) [Accessed on 12 January 2014]
12. CISCO catalyst 3560G – 2ATS. [www.cisco.com/c/en/us/Support/Catalyst-3560g-24ts-switch/model.html](http://www.cisco.com/c/en/us/Support/Catalyst-3560g-24ts-switch/model.html) [Accessed on 2 February 2014].
13. Spears, Ed. Parallel UPS configurations: Connecting multiple UPS modules for added capacity or redundancy: Eaton white paper. EATAN. 2009 <http://pqlit.eaton.com/ll-download-byilitcode.asp?doc-id=10925> [Accessed on 4 March 2014]
14. Reliability of parallel redundant UPS: Uninterruptible Power Supplies Ltd. White paper. [www.upspowerco.uk/system/site/uploads/content/docs/white-papers-20Sept-12/Reliability-of-parallel-redundant-UPS.pdf](http://www.upspowerco.uk/system/site/uploads/content/docs/white-papers-20Sept-12/Reliability-of-parallel-redundant-UPS.pdf) [Accessed on 5 October 2014]
15. International Electro Technical Commission. Degrees of protection provided by enclosures (IP code). IEC 60529: 2013. IEC, 2013.

## ACKNOWLEDGEMENTS

Authors would like to acknowledge the project team for the opportunity given for designing and implementation of power management system. The Instrumentation team for providing their valuable suggestion and support during the testing of PMS. Authors would like to thank Ms Lavanya, Sc 'D' of DRDL for providing technical information required to complete this study; Mr. S. Giridhar Rao, Sc 'F' and Mr Arif Khan, Sc 'D' of ASL for providing help for reliability analysis; Mr Hemant Kumar, Sc 'D' of ASL for providing support for literature survey, and Mr C. Srikanth for providing topographical support for writing this study.

## CONTRIBUTORS

**Mr Arun Kumar** is graduated in Electronics & Telecommunication Engineering from BIT, Ranchi University. He completed his MTech in Electronics Instrumentation (by research) from NIT, Warangal and he is shortly in the phase of obtaining his PhD from NIT, Warangal in the field of Instrumentation. Presently he is working as Technology Director in ASL, DRDO, Hyderabad. His research interests encompass the areas of fibre-optic, data communication, data acquisition, underwater instrumentation, high speed visual imaging, design and development of test jigs for missile systems.

In the current study, he has worked on design and implementation of the system.

**Dr L. Anjaneyulu**, did his BTech from Nagarjuna University before obtaining his MTech in EI from NIT Warangal. His varied R&D experiences cover working as Project Officer at DIAT, Pune where he was involved in Design and Development of Airborne and Surface borne RADAR Systems. Presently, he is an Associate Professor, Department of Electronics & Communication Engineering, NIT, Warangal. He evinces keen research interests in the area of antenna design, electromagnetic fields and waves, microwave and radar, computer networks, network programming, fuzzy logic and neural networks.

In the current study, he has reviewed and given valuable inputs and suggestions.