

Underwater Optical Instrumentation

R. N. SINGH & A. K. JAISWAL

Instruments Research & Development Establishment, Dehra Dun-248008

Received 16 January 1984

Abstract : The paper presents a brief review of instrumentation necessary for carrying out *in-situ* light associated measurements in sea water. Recent developments in this area of instrumentation have been brought out. Practical significance of various parameters measured by these instruments has also been highlighted.

1. Introduction

The sea water is well known to be a very good medium for the propagation of sound waves. As far as the electromagnetic spectrum is concerned, there are only two transmission windows: one in the Blue-Green (*B-G*) optical region ($430 \text{ nm} < \lambda < 570 \text{ nm}$) and the other in the *ELF* region ($\lambda > 3 \text{ Km}$). The *ELF* region has found only limited application in underwater instrumentation. The transmission window in the *B-G* optical region has, however, been used for applications in the area of imaging, ranging and communication, **inspite** of the fact that light may have losses thousand times as great as those of low frequency sound waves. There are two distinct advantages of working in the optical window. **Firstly**, the capability of light waves to penetrate air-seawater interface without any significant loss due to which depth-ranging, detection of submerged targets and underwater-communication is made possible from an aerial platform. **Secondly**, the resolution possible in optical region is in several order of magnitude superior to that achievable with acoustical imaging systems, whereas propagation loss of ultrasonic waves of frequency above 100 KHz becomes comparable to those of *B-G* light waves in clear ocean water.

The aim of the paper is to present a brief review of instrumentation^{1,2} necessary for carrying out *in-situ* light associated measurements in sea water. A brief mention has also been made of various sea water optical parameters, which affect the performance of optical and electro-optical sensors in underwater application.

2. Underwater Optical Parameters

There are two basic light-loss mechanisms in propagation through sea water : the absorption and the scattering. Absorption is the conversion of light energy into heat energy, whereas scattering is the redirection of energy by the presence of scatterers. Both of them depend on the wavelength of light. When a collimated beam of monochromatic light travels a pathlength I through water such that residual beam does not contain any scattered light flux then the attenuation suffered by the beam is described by the exponential law

$$P_l = P_0 e^{-\alpha I}, \quad \alpha = a + s, \quad (1)$$

where

P_0 = initial power of the collimated beam

P_l = power of the residual beam

I = water pathlength

a = absorption coefficient

s = scattering coefficient

α = beam attenuation coefficient of water

The light loss in the medium may also be described by the reciprocal of the attenuation coefficient α , the characteristic pathlength L_e , which is a measure of the distance at which the power is diminished by a factor of $1/e$.

Underwater optical parameters may broadly be classified as two types : (1) Inherent optical parameters, (ii) Apparent optical parameters. The former are those which do not depend on the ambient lighting conditions and are also independent of the orientation of the measuring instrument. These include a , s , α and the volume scattering function $a(\theta)$, of which a is the most basic and useful parameter as it describes the attenuation of the direct image forming light.

Underwater radiance distribution in presence of ambient or artificial illumination is an apparent optical property of sea water. So are the relative irradiance distribution as a function of depth, the diffuse attenuation coefficient, and the underwater visibility. All of these parameters depend in a complicated way on the intrinsic optical parameters 'a' and 's'.

Various light-loss coefficients and other optical parameters mentioned above vary from place to place in sea-water, with depth and time. For instance, the beam attenuation coefficient α may be as low as 0.02 for the clearest ocean water and as high as 1.0 for very turbid water near harbours. Hence, there is a need to carry out *in-situ* measurement of these parameters in geographical locations of interest. The following section describes the instrumentation necessary for carrying out these measurements.

3. Instrumentation

A few general remarks may be made regarding optical oceanographic instruments. The usual engineering problems of working underwater must be taken care of in hardware design. Water tight enclosures, ease of handling and use at sea, optical and electrical stability are some of the important considerations.

3.1 Beam Transmissometer (alpha-meter)

The beam transmissometer, used for the measurement of the beam attenuation coefficient α , is the most basic tool of the optical oceanography. The instrument system consists of three major components : (i) underwater optical unit for the measurement of alpha. This unit may also incorporate sensors for water temperature and instrument depth measurement, (ii) Cable for data transmission, (iii) A deck-unit for signal processing, data **display/recording** and functional control of the underwater unit.

The optical unit of a beam transmissometer consists of a projector and a receiver subsystem, optically aligned at a fixed distance apart on a rigid mount as shown in Fig 1. The optical path between the two subsystems is filled with sea-water when the instrument is submerged in water. The projector, consisting of a light source, the condenser lens system, the field stop and the objective lens produces a well collimated beam of light which travels a fixed pathlength l through water before entering the receiver through a window. The receiver has a very narrow acceptance angle, determined by the focal length of the receiver objective lens and the field stop size. A narrow spectral band-pass filter, matching the spectral transmission of sea-water e.g. Wratten 61, is inserted in the optical path just before the photocell. A filter wheel with a number of filters may also be incorporated if the instrument is desired to measure α at a number of discrete wavelengths. The detector is usually a silicon photodiode. In more sophisticated instruments, a photonmultiplier tube with an

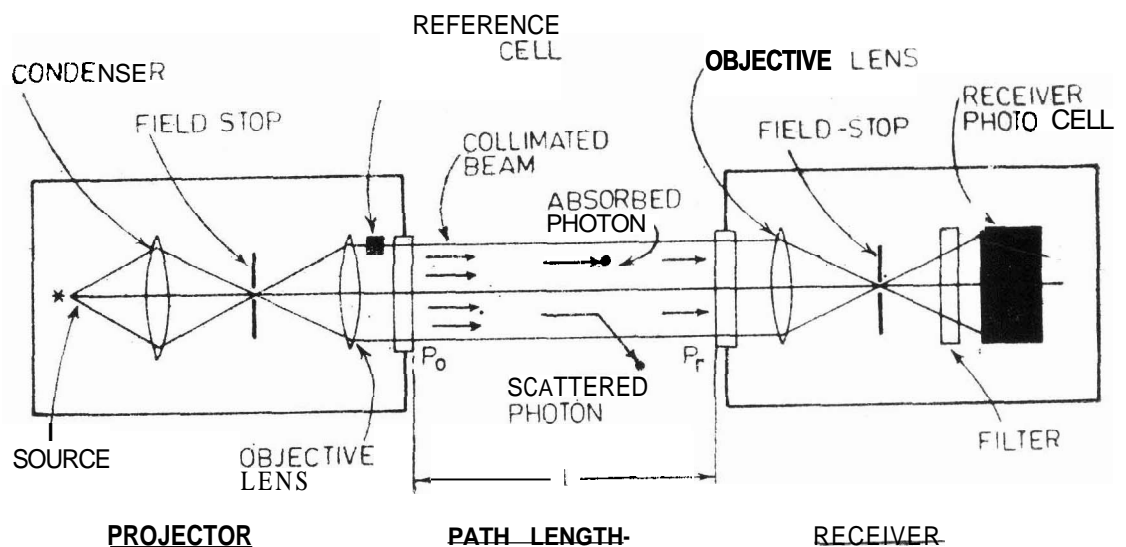

Figure 1. Schematic diagram of a beam transmissometer

integrating sphere is used to enhance the sensitivity. The projector system incorporates a reference photocell which monitors the fluctuations in light-source output. To compensate for receiver sensitivity variations as well, a portion of the flux from the lamp may be carried by a fibre-optic bundle to the receiver to serve as a **continual** reference signal for the system.

The magnitude of α is determined from the transmittance T measurement by the relationship $a = \frac{1}{l} \ln \left(\frac{1}{T} \right)$. The amount of light lost due to reflection at the window surface with a water path is different from that lost at the window surface with an air path. Thus the instrument calibrated in air will introduce a small error when immersed in water, for which a correction is incorporated in the calculation of α .

The measurement of α is complicated due to the fact that the measurement is affected by a number of instrument design parameters. The most important aspect to be considered is the receiver acceptance angle. By definition, $\alpha = a + s$ i.e. α is the total attenuation suffered due to absorption and scattering. Therefore, if a photon is absorbed or scattered within the pathlength, it should be permanently lost to subsequent detection by the receiver. To distinguish unscattered light from the light scattered into very small angles, the receiver acceptance angle should be vanishingly small, which is difficult to achieve in practice. The problem is significant because small angle scattering dominates the total scattering phenomenon in natural waters. In a good instrument design, both the receiver *FOV* and the projector beam divergence must be kept in the milliradian range. The effect of finite receiver acceptance angle is to yield a measured value which is less than the true value of α .

The measured value of α also depends on the beam diameter, the beam divergence, the pathlength and the receiver aperture size, as shown by Williams²⁻³. A beam transmissometer tends to be most accurate when the pathlength l is in the region of the critical pathlength l_c . This condition is, however, difficult to meet as the instrument may be required to be used in different types of water with vastly different α . It has also been suggested that by employing a dual beam unit in such a way that instead of comparing the transmittance in air and water over the same pathlength, the comparison is made between two similar water pathlengths, one greater than the other, the dependence of measurement on the instrument geometry may be eliminated to a great extent.

The optical system for some of the a -meters utilise cylindrically limited beam rather than a collimated beam as described previously. The optical schematic for such a system is the same as shown in Fig. 1 except that projector's objective lens images its field stop at the receiver entrance aperture stop. The field stop is of such a diameter that its image is of the same size as that of the projector's objective aperture stop. The design of receiver optics is similar. The merits and demerits of such a system have been discussed in reference⁴.

Use of narrow spectral band-pass filters is essential for the measurement of α . When the source-receiver combination has a broad spectral response, the energy distributed over wavelengths, which do not match with the spectral transmission of water, is attenuated very sharply with path length. Thus the value of α changes markedly with pathlength, being much higher for shorter pathlengths.

The additional details on beam transmissometers may be found in references¹⁻⁸.

3.2 Relative Irradiance Meter

The second most basic tool of optical oceanography is the irradiance meter, which collects radiation from the hemisphere in a 180° FOV. This is in contrast with the receiver optics of a beam transmissometer, which should theoretically have an acceptance angle of 0° . Measurement of irradiance further implies that radiation striking the receiver surface at a certain angle must produce a response proportional to the cosine of the angle of incidence with respect to the normal to the surface. Such a device is known as a 'cosine-collector' and has been shown in Fig 2(a). The opal-glass at the input to the receiver transmits an amount of light very nearly according to the cosine law. It may however be mentioned that the behaviour of the opal-glass may change when immersed in water and the device must be tested for its suitability in underwater irradiance measurement.

Measurement of irradiance on two different horizontal planes at different depths in sea water is used to determine another optical oceanographic parameter of great interest and physical significance, the 'Diffuse Attenuation Coefficient' is normally denoted by symbol K . A surface irradiance meter monitors the fluctuations in the incident flux as shown in Fig 2(b). Another photosensor facing upwards measures the amount of diffuse downwelling light at depth z . If the irradiance at two different planes at depths z_1 and z_2 is H_{z_1} and H_{z_2} respectively, then the coefficient K is given by

$$H_{z_2} = H_{z_1} e^{-K(z_1 - z_2)} \quad (2)$$

The attenuation coefficient K is thus a measure of the extent to which diffuse downwelling day-light diminishes exponentially with depth. Coefficient K determines the amount of natural illumination available at various depths in sea water. When the

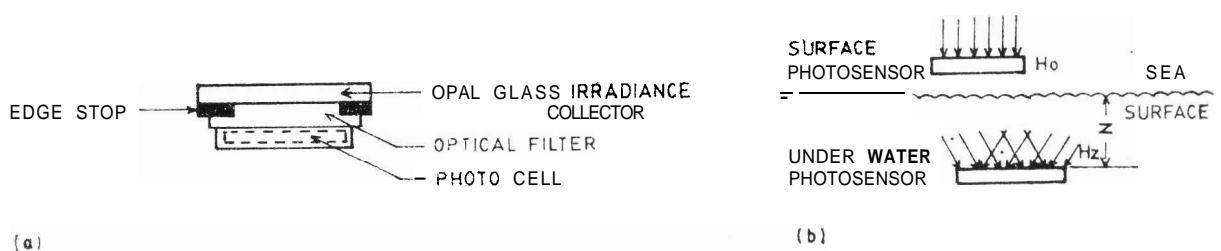

Figure 2. (a) Irradiance collector
(b) Measurement of diffuse attenuation coefficient K

sensor is made to look vertically downwards, it measures the amount of upwelling radiation. The ratio of the upwelling radiation to that of the downwelling radiation at a particular depth is a measure of the water reflectance at that depth. The diffuse attenuation coefficient therefore determines the inherent contrast of submerged targets and may be used to estimate the visible range.

The diffuse attenuation coefficient K depends on the basic light loss parameters a and s , however, the physical process involved in the attenuation of irradiance is quite different from that involved in the attenuation of a collimated beam of light. Because of the 180° FOV of the irradiance collector, most of the scattered light except for the back-scattered component does reach the receiver surface albeit after travelling a longer optical path thus suffering additional absorption. The light loss due to scattering is, however, considerably less. K is, therefore, smaller than a and a number of investigators have tried to derive empirical relationships between the two on the basis of extensive measurements⁵.

The workers^{6,7} at the 'Visibility Laboratory' of the Scripps Institute of Oceanography have developed an integrated oceanographic transmissometer, dual irradiance-meter instrument system wherein a single instrument simultaneously measures the beam attenuation coefficient, the downwelling irradiance and the upwelling irradiance. The system also incorporates a surface irradiance meter unit and is an automated, state-of-the-art system incorporating on-board computer for quick acquisition of high quality data on α , K and inherent target contrast. It has been shown by Duntley¹ that knowledge of these parameters is sufficient for a theoretical estimation of visibility of submerged objects. Instruments for direct measurement of underwater visibility have been described in the following section.

3.3 The Secchi Disc and In-Water Contrast Measuring Devices

The Secchi Disc is a white disc that is lowered into the water until it just disappears from the view. The disappearance depth is taken as a measure of water transparency. The Secchi Depth is only a crude measure of visible range since, in addition to water transparency, it depends upon a number of unrelated factors, including the size and reflectance of the disc, the viewing and lighting geometry, and the water surface conditions². The size of the disc is not a very critical parameter if the disc subtends a large enough angle at the eye at the disappearance depth. Uncertainties due to the surface condition may be eliminated by viewing the disc from inside the water. The viewer may also use filter glasses to match the sun-disc-filter-eye in response to that of the spectral transmission of water.

Patterson *et al*⁹ have developed a contrast meter which can be used for an objective assessment of visible range. The operating principle of the instrument is illustrated in Fig. 3. Two targets of known and differing reflectances, a and b , are mounted at a fixed distance D from a focusing device, A pair of photoresistors are

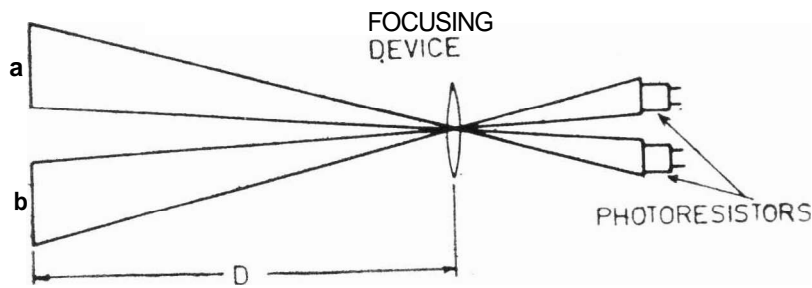

Figure 3. Contrast meter.

mounted in the image plane of the lens so that one is illuminated by the image of the darker target area, while the other is illuminated by the image of the lighter area. In air, the ratio of irradiance on the two photoreceptors depends totally on the reflectance of the two target areas. When the device is submerged in water, the loss in contrast can be determined from the photosensor output, which in turn can be related to the visible range. The unique feature of the instrument is that the target characteristics, pathlength and lighting geometry can be modified to approximate the situation of interest.

3.4 Under Water Radiance Measurement

Measurement of radiance distribution of **natural/ambient** illumination as a **function** of depth in sea water is useful for two reasons. Firstly, it is a measure of angular distribution of flux which varies with solar zenith angle and depth. Secondly, the radiance data may be integrated to evaluate the upwelling and downwelling irradiance and the apparent target contrast which are necessary for determination of underwater visibility.

Radiance is the flux per unit (projected) area per unit solid angle in a specific direction. In the conventional method of measurement, an optical receiver having a narrow acceptance **angle** is mounted on a two-axis gimbal and measurements are recorded for all angles of azimuth and elevation about a fixed point.

The above is a very cumbersome and time consuming **method** of acquiring radiance data. **Smith**¹⁰ has proposed the use of a fish-eye lens camera for quick acquisition of radiance data using photographic photometry. All photographic cameras map object space radiance into film plane irradiance. **Irradiance** determines the exposure and hence the recorded film density. The fish-eye lens has a number of specific advantages over conventional lenses. Firstly, it covers a 180° field of view. Secondly, the projection of a fish-eye lens is an equidistant projection wherein the **image** position is in direct relation to the angle of incidence, i.e., $r = f \theta$, where **f** is the focal length of the lens, θ is the angle of an incident ray, and **r** is the coordinate of the image of this ray on the plane of the film. Thirdly, in contrast with ordinary lenses for which film plane irradiance drops as $\cos^4 \theta$, **the** irradiance due to a fish-eye

lens is relatively uniform following a $(\sin \theta/\theta)$ law. Using the fish-eye lens camera, the entire radiance distribution in a hemisphere can be recorded in a single exposure.

3.5 Scattering Meters

In-situ measurement of volume scattering function i.e. the angular distribution of scattered intensity as a function of scattering angle is of interest for a number of reasons. In turbid waters, scattering is the major source for the attenuation of light beam. A typical curve for the volume scattering function shows a very strong peak at small angles in the forward direction and another strong peak in the backward direction. Forward scattering is responsible for the broadening of a laser beam propagating in sea-water. It is also a source of degradation in resolution of imaging systems. The strong component in the backward direction is responsible for contrast dilution in active imaging systems. Furthermore, beam transmissometers and relative irradiance meters measure some combination of a and s . To solve certain problems in underwater application, it is necessary to know the individual values of a and s . Integration of the volume scattering function over all scattering angles yields the individual value of s . If a has been measured separately, the individual value of n can also be determined.

Jerlov¹¹ has designed and built a number of scattering meters. Fig. 4 is the schematic diagram of a typical instrument, illustrating the basic principle of operation. A collimated beam illuminates a volume of water that scatters light in all directions. The volume of water that acts as a scatterer is determined by the volume common to the source beam and the imaginary beam produced by the receiver as shown in the figure.

Conventional scattering meters are unable to measure $\sigma(\theta)$ for narrow forward angles as they are unable to distinguish the scattered light from the undeviated light.

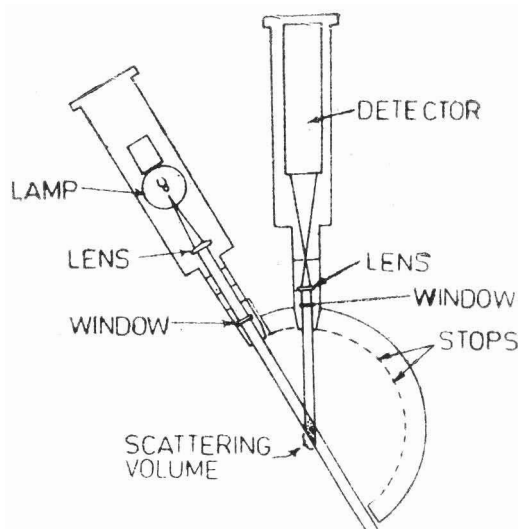

Figure 4. Scattering meter.

Austin *et al*⁶ have designed an instrument which is capable of measuring the narrow angle volume scattering function in addition to the beam attenuation coefficient. This is made possible by using a set of annular field stops in the receiver optics of the transmissometer (*c.f.* Fig I), such that the central opaque part of the stop blocks the direct beam. The annular transparent segment of the stop accepts flux which has been scattered by the water in a small range of **angles** around the desired median angle.

3.6 Absorption Meters

To be able to directly measure the absorption coefficient a , it is necessary to eliminate or minimise the effect of scattering in the measurement setup. Sorenson and Honey¹² of Stanford Research Institute have designed an instrument which uses an isotropic source of light and a cosine detector. The distance between the two can be varied. The power received by the detector for two different separations between the source and the receiver is measured and used to calculate the absorption coefficient a . The instrument works on the premise that the cosine receptor with 180° **FOV** accepts most of the scattered radiation through multiple scattering, and the attenuation is essentially due to absorption.

4. Conclusion

We have endeavoured to present a brief review of instrumentation necessary for carrying out *in-situ* light associated measurements in sea water. Mention has also been made of more recent developments in this area of instrumentation.

In view of a bigger Naval threat due to larger coastal area of our country, as also the latest **electro-optical** technologies being adopted in submarine warfare, the need for a detailed and systematic study of sea-water optical parameters can not be ignored. As such, indigenous development of instrumentation described above and study of these parameters needs immediate attention.

References

1. Hill, M.N., *The Sea* Vol. 1 (Interscience Pub Ny), 1962.
2. Williams, J., *Oceanographic Instrumentation*, (1973).
3. Williams, J., *Trans. Instrum. Soc, Amer.*, 11 (1972).
4. Petzold T. J., *et al.*, SPIE, 12 (1968), 133.
5. Shannon, J. G., SPIE, 64 (1975), 3.
6. Austin, R. W., *et al.*, SPIE, 64 (1975), 50.
7. Austin, R. W., *et al.*, SPIE, 160 (1978), 49.
8. Bartz, R., *et al.*, SPIE, 160 (1978), 102.
9. Patterson, R. B. *er al.*, SPIE, 64 (1975), 12.
10. Smith, R. C., SPIE, 12 (1968), 101.
11. Jerlov, N. G., 'Optical Oceanography', (Elsevier Publishing Co.. Amsterdam), 1968.
12. Sorenson, G., SPIE, 12 (1968), 115.