

FEM Analysis of Gun Tank Turret

G. Narasimhan

Combat Vehicles Research and Development Establishment, Avadi, Madras-600 054

and

N. Sivaprasad

Department of Mechanical Engineering

Indian Institute of Technology, Madras-600 036

ABSTRACT

Turret of a battle tank is of complicated geometry with complex loading conditions. Finite element analysis of turret structure is carried out by using a package program SAP IV for various loadings. Experimental analysis is carried out by strain gauge method on 1/5th scale model and the results are compared. The suitability of finite element method in this area of stress analysis of tank turrets to assess the design adequacy and optimisation becomes apparent.

1. INTRODUCTION

A tank is a heavily armoured, highly mobile combat vehicle. Turret is the upper part of the tank. Current tanks are provided with fully closed revolving turrets in which primary weapons are mounted. Turret forms an armoured enclosure for tank crew and various subsystems like sight, ammunition, gun control, etc. Traditionally tank turrets were constructed out of steel plates of considerable thickness to keep away the enemy projectiles. These thicknesses are generally far in excess of that required for the structural strength consideration.

The requirement of heavy steel armour to counter the latest antitank weapons and the necessity of high mobility to the present day tanks have led to the development of new type of armours such as the composite armour. The composite armour is made up of different layers of different materials (ceramic, GRP, nylon and lighter alloys) sandwiched between the main turret structure and a light external plate. The steel

plates of the turret main structure with the added composite and outer plate gives the required immunity against enemy attack. Either the composite or the lighter outer plate contribute to the structural strength of the turret. The turret main structure, therefore, should have the sufficient strength to withstand the various loadings such as gun recoil force. One such turret structure is analysed in this paper to assess the design adequacy and for obtaining a possible optimum solution.

2. FEM ANALYSIS

Gun tank turret shown in Fig. 1 is a three dimensional welded structure of varying plate thickness. The existing conventional methods are not sufficient to find even an approximate solution of the problem. In the absence of any other convenient method, it is felt that finite element method (FEM) is the best numerical method of all for solving such problems. SAP IV which is a general purpose structural analysis program for static and dynamic analysis is used for stress analysis of turret.

2.1 Discretization

The discretization of the structure into subregions (finite elements) is the first step in FEM. The process of discretization essentially is an exercise of engineering

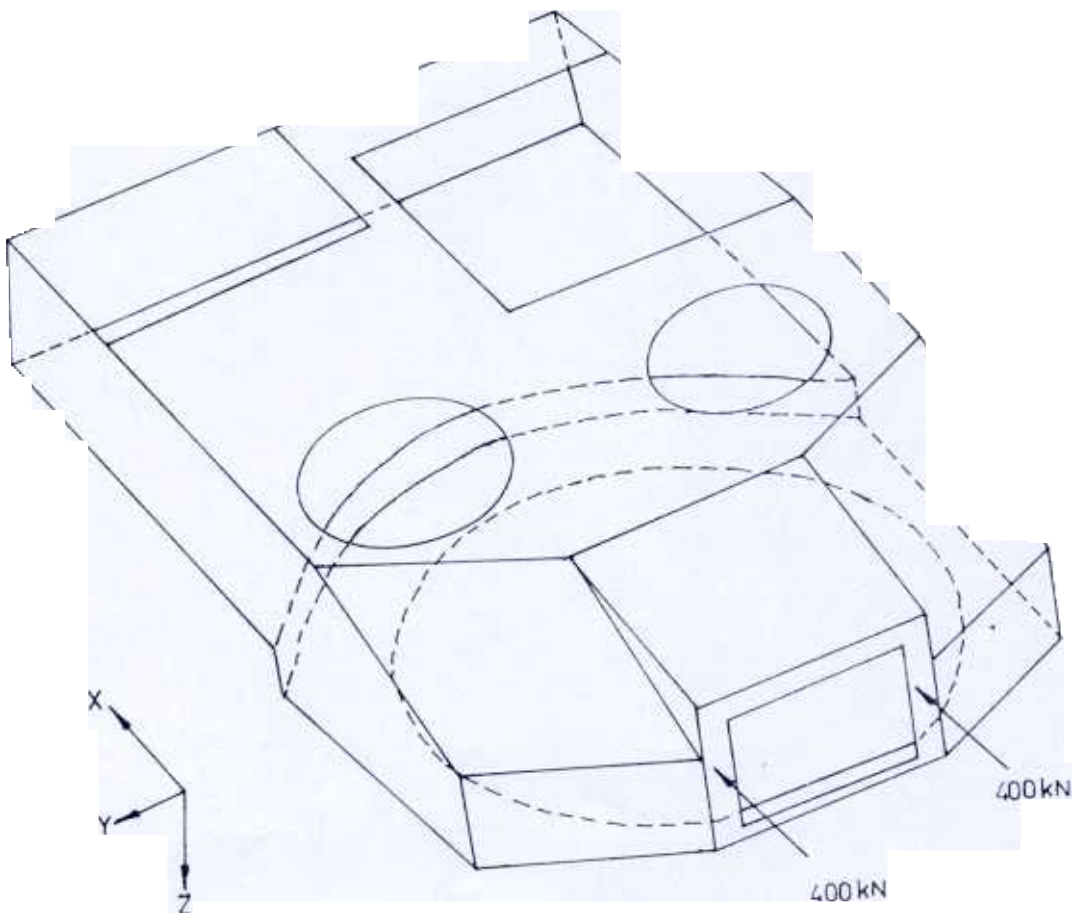

Figure 1. Pictorial view of turret.

judgement. Considering the geometry, nature of loads and displacement pattern, thin plate and shell element of SAP IV element library¹ are used.

The turret structure is discretized into 183 elements with 213 nodal points. A refined mesh size is taken in the front region of the turret where load is applied and high stress concentration is expected. Nodal points are selected on locations at which there is discontinuity in plate thickness to get elements of constant thickness. The discretization on the developed surface of the turret is shown in Figs. 2 and 3.

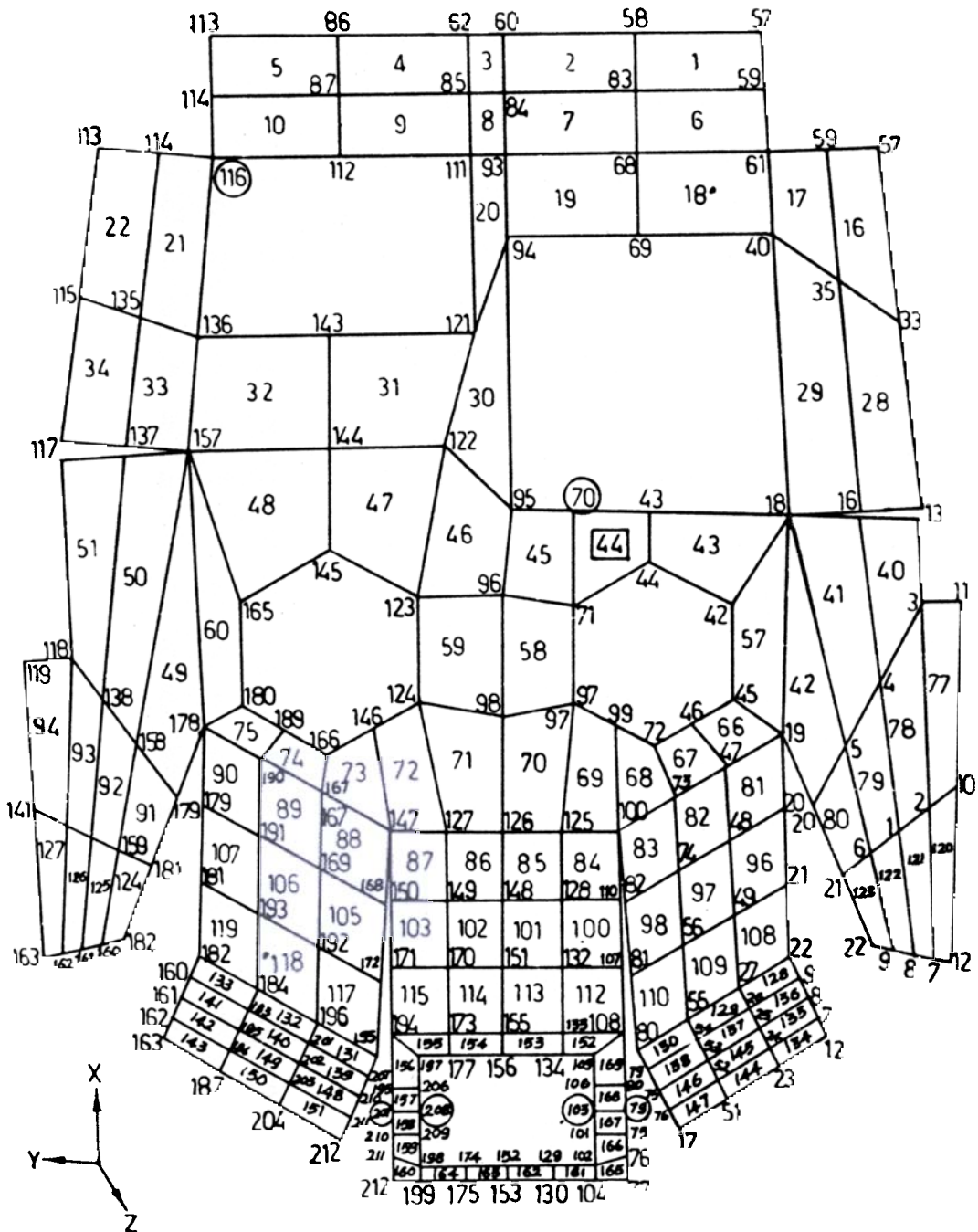

Figure 2. Turret discretization (top and four side plates).

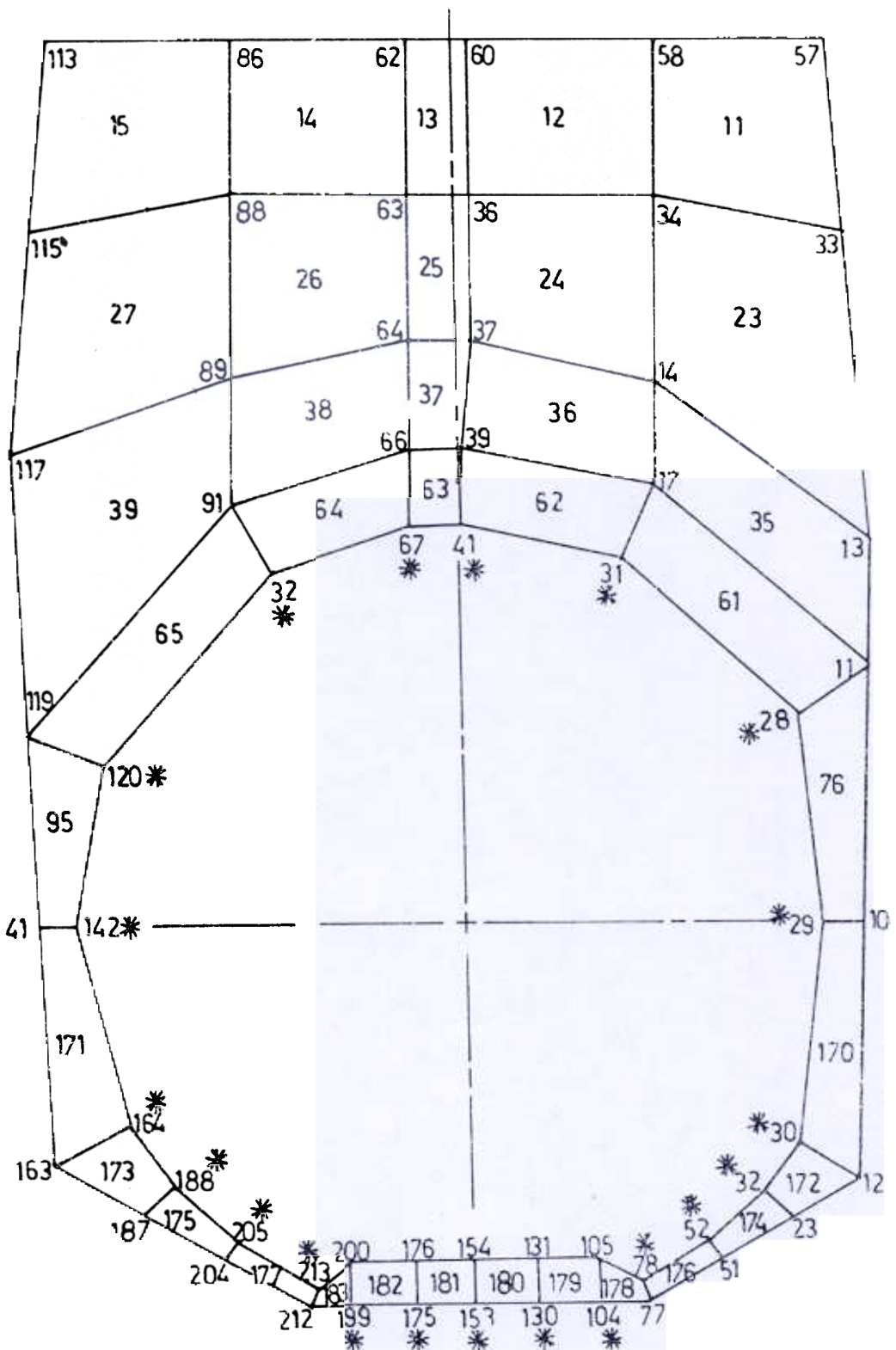

Figure 3. Turret discretization (bottom plate).

2.2 Bandwidth Reduction

To minimise the memory requirement and computational time, it is essential to optimise the bandwidth of global stiffness matrix for the problem of this nature. The bandwidth depends on the node numbering scheme and the number of degrees of

freedom considered per node. Since the number of degrees of freedom per node is generally fixed, the bandwidth can only be minimised by proper node numbering.

Nodal points are initially numbered in certain sequence. Element connectivity data are prepared based on this initial node numbers and used as input for the program developed based on the algorithm described by Collins² for automatic nodal renumbering. This program output gives original node numbers and the corresponding new node numbers generated. By this node renumbering exercise, the bandwidth is reduced to 168 from the original 366.

2.3 3-D Pictorial View Generation

It is important to give error-free input data to any finite element package. To ascertain the correctness of the input data, a graphic program is written to generate the objects from the discretized input data. The turret discretization plots are obtained in various viewing angles and discretization is verified. One such plot is shown in Fig. 4.

The turret structure is analysed for the gun recoil force 800 kN acting on the front plate as shown in Fig. 1. The turret bottom plate is bolted rigidly to the ball race assembly. To simulate this bolted condition, all the nodal displacements and rotations of the nodes of bottom plate (marked with asterisk in Fig. 3) are suppressed. The total solution time for this problem on an IBM 370 computer is 12.3 CPU-minutes.

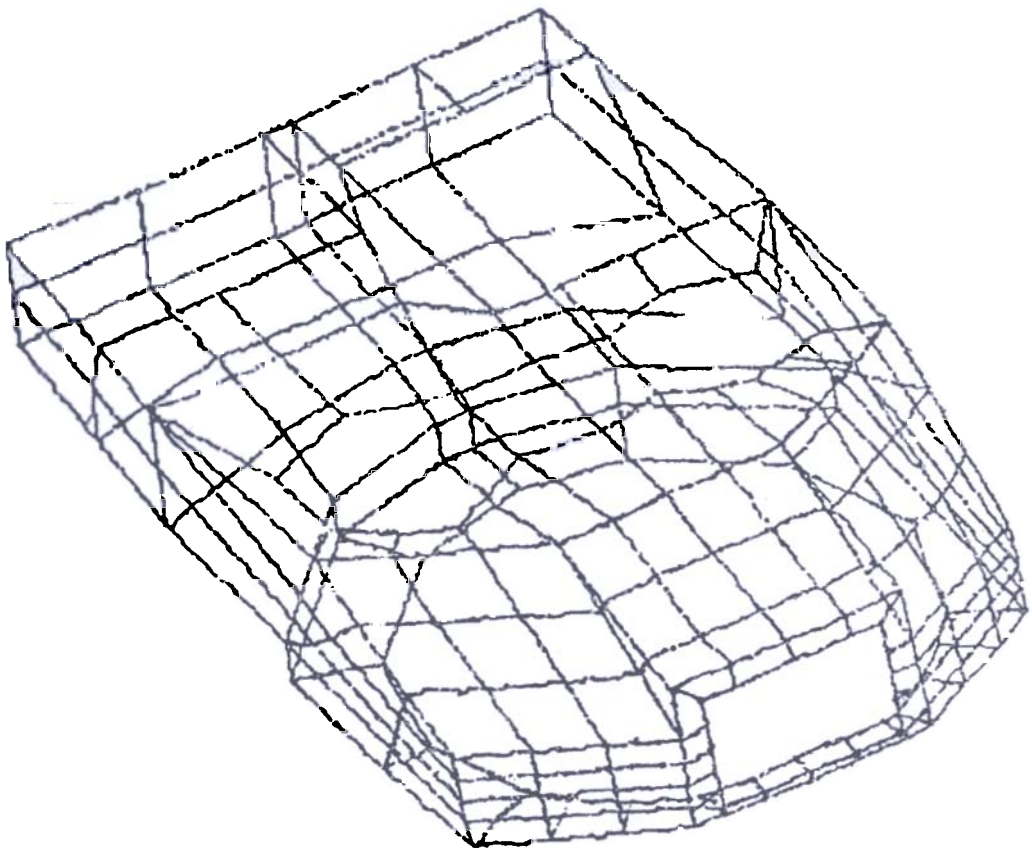

Figure 4 Graphic generated turret.

3. EXPERIMENTAL STRESS ANALYSIS

Experimental stress analysis by strain gauge method is carried out to find stresses at a few selected locations on the 1/5th size model turret to compare and check the FEM results.

3.1 Model and Scale Factor

It is essential to understand the relationship between phenomenon observed in a scaled model and the corresponding effects in a full size turret. The following relations³ can be written comparing various quantities in prototype and model.

$$\text{Load ratio : } W_r = \frac{W_p}{W_m} \quad (1)$$

$$\text{Bending moment ratio} = \frac{W_p \cdot L_p}{W_m \cdot L_m} = W_r \cdot L_r \quad (2)$$

$$\text{Bending stress ratio} = \frac{W_p \cdot L_p \cdot Y_p \cdot I_m}{W_m \cdot L_m \cdot Y_m \cdot I_p} = \frac{W_r}{L_r^2} \quad (3)$$

To compare the stresses obtained by FEM on full scale prototype under recoil force of 800 kN, the load to be applied on the model is worked out using the Eqn. (3) assuming bending stress ratio is equal to one. That is $(W_r/L_r^2) = 1$.

Since the model is of 1/5th size, $L_r = 5$, $W_r = 5^2 = 25$, and $W_p/W_m = 25$.

$$\text{The load applied on the model} = W_m = \frac{W_p}{25} = \frac{800}{25} = 32 \text{ kN}$$

3.2 Strain Measurement

Strain gauges are bonded on the turret model at ten locations as shown in Fig. 5. Three-element rectangular rosette configuration is used in all the locations. The turret model is mounted vertically with the help of a fixture on universal testing machine and 32 kN load is applied. This arrangement is shown in Fig. 6. The strain measurements are taken and stresses are calculated.

4. RESULTS AND DISCUSSION

Concentrated load of 200 kN at nodes 79, 103, 207 and 208 are applied to simulate the recoil force of 800 kN. The resulting deflections and stresses at selected locations are given in Tables 1 and 2 respectively. The maximum displacement is 0.445 mm in the direction of loading and takes place at the point of loading (at the nodes 103 and 208). The maximum downward displacement is 1.23 mm and it is at the node 11. This is due to the overhang of turret rear bustle. The general displacement pattern is in line with that of any standard structural problem.

The stresses obtained by experimental analysis on the turret model are compared with those of FEM in Table 3. It may be seen from Table 3 that the FEM values are fairly comparable with experimental values in most of the locations. The wide variation

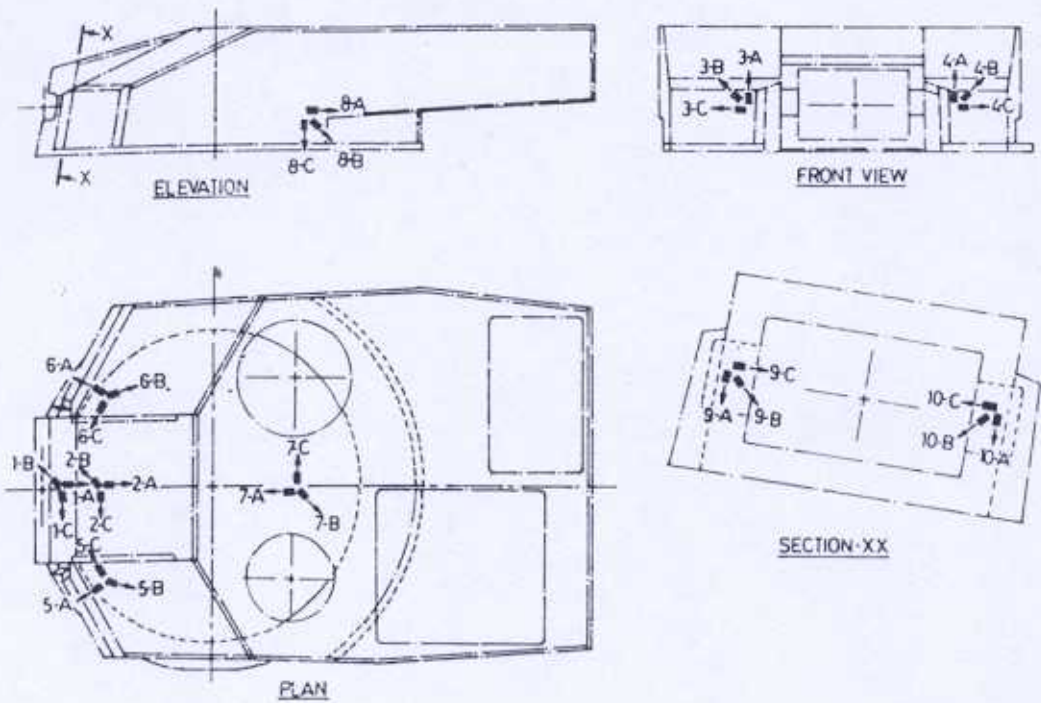

Figure 5. Strain gauge locations on turret model.

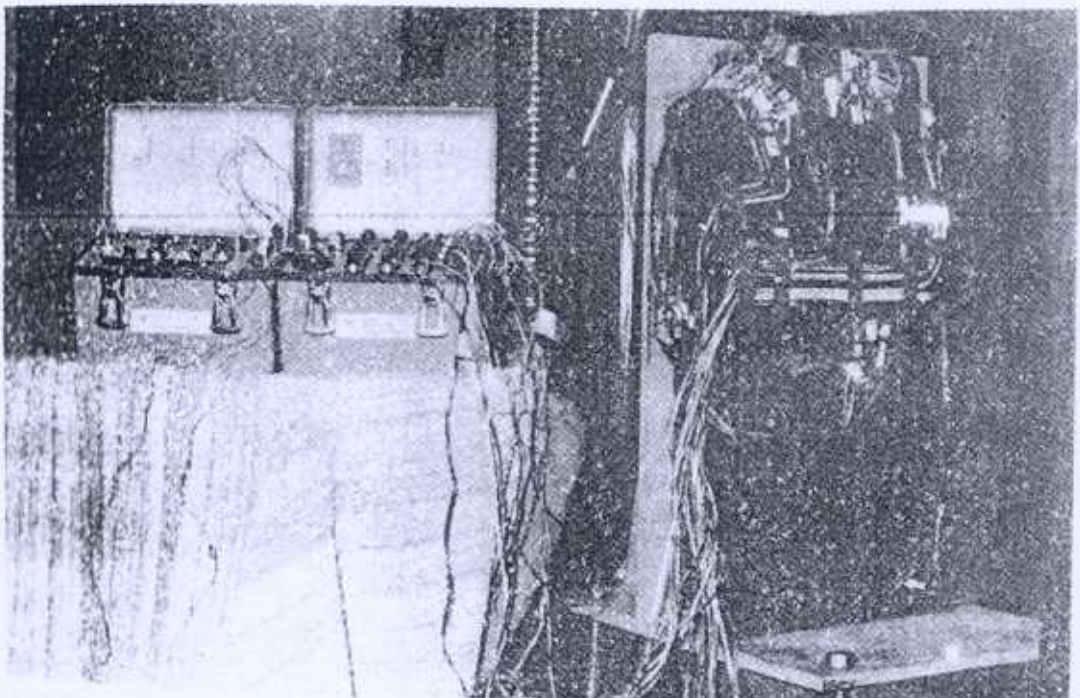

Figure 6. Turret model under load in UTM.

of values at serial numbers 8, 9 and 10 may be due to faulty strain gauge installation. However these values are insignificant as they are very small. Generally the results indicate that the stress values are very much within the safe allowable limit and the turret structure is fully safe against gun recoil force.

Table 1. Deflection due to recoil force

Sl. No.	Location (node no.)	Deflections (mm)		
		<i>x</i>	<i>y</i>	<i>z</i>
	207	0.350	-0.123	-0.099
2.	208	0.445	-0.155	-0.098
3.	155	0.322	0.013	-0.229
4.	182	0.195	-0.045	-0.049
5.	126	0.346	0.002	-0.128
6.	178	0.320	0.031	0.234
7	95	0.337	-0.012	0.519
8.	157	0.321	-0.001	0.703
	93	0.331	0.021	118
10.	116	0.323	0.026	.231

Table 2. Stress due to gun recoil force

Sl. No.	Element No.	Stress (N/mm ²)
	158	100.7
2.	157	78.7
3.	131	45.6
4.	130	50.2
5.	114	19.2
6.	110	18.4
7.	77	17.0
8.	178	69.7
9.	37	14.0
10.	45	5.0

The FEM analysis is extended to different loadings and the results are discussed in the succeeding paragraphs.

Modern tanks have capability of submerged operation up to a depth of 5 m in water. Analysis is carried out by calculating water pressure on each element. The resulting deflections at selected locations are given in Table 4. The maximum downward (lateral) displacement of top plate at node 70 is 4.82 mm. This is due to the large surface area of top plate, supported only at the edges. The maximum stress is

Table 3. Comparison of stresses experimental values with FEM values

Sl. No.	Location	Gauge number	Experimental value (N/mm ²)	FEM value (N/mm ²)	Approx. element number
1.	Portal plate (RH)	10	107.42	100.7	158
2.	Portal plate (LH)	9	99.30	98.0	167
3.	Front plate (RH)	3	20.19	28.2	139, 140
4.	Front plate (LH)	4	12.60	16.5	137
5.	Sloping plate (RH)	6	13.87	12.2	105, 117
6.	Sloping plate (LH)	5	12.36	13.1	98, 109
7.	Side plate (LH)	8	9.84	11.7	77, 78
8.	Top plate	7	1.57	3.0	58, 59
9.	Glacis plate	2	2.88	9.7	101, 102
10.	Portal plate	1	4.19	-	-

LH = Left hand side, RH = Right hand side

Table 4. Deflection of turret top plate by FEM

Sl. No.	Node number	Deflection (mm)
1.	98	1.48
2.	96	3.71
3.	124	1.54
4.	144	2.20
5.	122	4.33
6.	70	4.83
7.	71	3.41
8.	43	3.39
9.	95	4.80
10.	121	3.39

42.4 N/mm² and it is on the element 44. This downward deflection can be reduced by providing stiffeners connecting bottom plate and top plate in possible locations.

Gun elevation cylinder shown in Fig. 7 is attached to the turret bottom plate through the mounting bracket. The mounting bracket and the turret bottom plate are discretized as shown in Fig. 8 independent of turret structure. Elevation cylinder force (150 kN) acting along the axis of cylinder is resolved in the x and z directions and

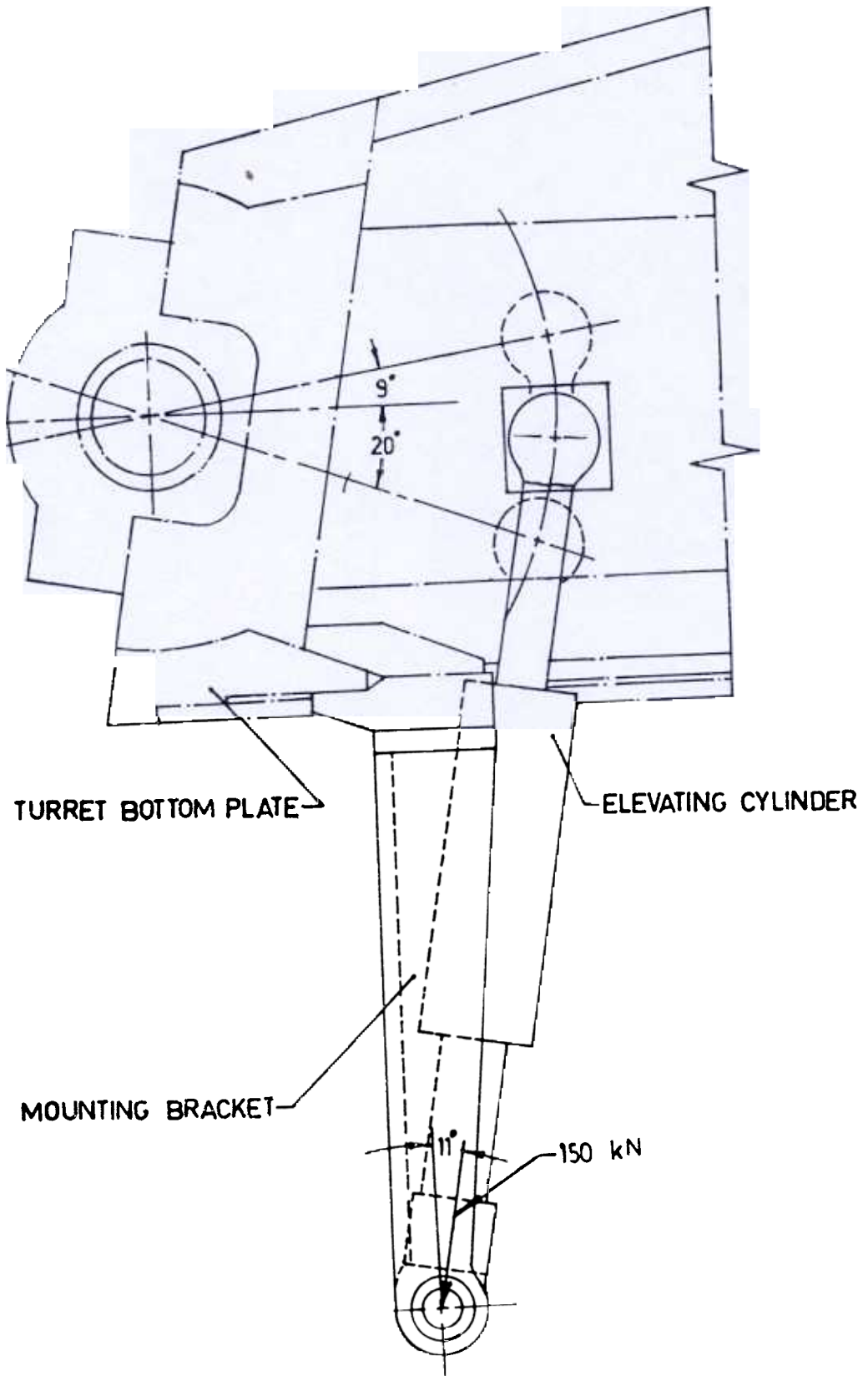

Figure 7. Elevating cylinder mounting.

applied as shown in Fig. 8. The deflections obtained at some selected nodes are given in Table 5 and the stresses at some selected elements in Table 6. The node numbers selected are indicated inside the circle and element numbers inside square in Fig. 8. The maximum x -translation at the node 166 is 3.4 mm and maximum stress on the element 103 is 276.4 N/mm^2 . By properly reinforcing the turret bottom plate and bracket, the stresses and deflection can be brought down to allowable range.

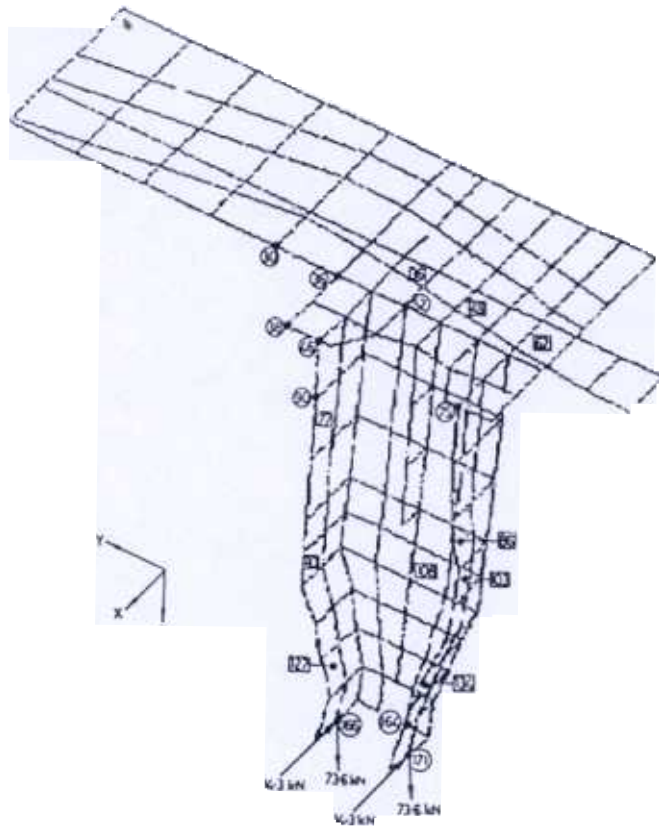

Figure 8. Graphic generated view of elevating cylinder mounting bracket.

Table 5. Deflections in elevating cylinder mounting by FEM

Sl. No.	Node number	x -translation (mm)	y -translation (mm)	z -translation (mm)
1	30	-0.0031	0	
2	36	-0.0039	0.0009	
3	38	-0.0044	0.0020	
4	46	-0.0052	0.0020	
5	52	-0.0035	0.0012	
6	75	-0.0028	0.0030	
7	90	-0.258	0.048	
8	164	-2.762	-0.348	
	166	-3.402	-0.844	
10	171	-3.230	-0.428	0.731

Table 6. Stresses in elevating cylinder mounting by FEM

Sl. No.	Element number	Max. stress (N/mm ²)
	36	86.7
2.	49	123.9
3.	62	230.
4.	77	99.8
5.	86	124.5
6.	110	228.6
7.	103	276.4
8.	108	115.8
9.	127	220.8
10.	134	215.

5. CONCLUSIONS

FEM analysis could give vital information about stresses and deflections in different locations of turret structure. It is established that FEM can be applied in the design and analysis of fighting vehicle hulls and turrets.

ACKNOWLEDGEMENTS

The authors are thankful to Shri. T.K. Das, Director, Combat Vehicles Research and Development Establishment, Avadi for extending all the facilities and granting permission to publish this paper. The authors would like to acknowledge the useful discussions and suggestions made by Shri R. Santhanam, Project Director (MBT) and Shri A. Selvaraj, Deputy Director (Hull & Turret) in the course of this work.

REFERENCES

1. Klaus-Jurgen, Bathe, Wilson, Edward, L. & Peterson, Fred E., SAP IV-A Structural Analysis Program for Static and Dynamic Response of Linear Systems, (MIT, Cambridge).
2. Collins, R.J., *Int. J. of Num. Meth. in Engg.*, 6 (1973), 345-346.
3. Hendry, A.W., *Elements of Experimental Stress Analysis*, (Pergamon Press, Oxford), 1977.