



SHORT COMMUNICATION

Avenues for Underwater Propulsion

C.P. Ramanarayanan

Naval Science & Technological Laboratory, Visakhapatnam-530 027

ABSTRACT

This study reviews thermal propulsion systems related to underwater application, covering the conceptual idea, the technology and the mechanism. Some of the salient features of the stored chemical energy propulsion system (SCEPS) technology and the unconventional engines are discussed. While these systems have generated considerable interest in the west, they are still new in India.

1. INTRODUCTION

The propulsion package for underwater use, whether it is for a weapon or for a vehicle, is entirely different from standard packages, the basic reason being the surrounding media—water. This factor plays an important role in case of thermal propulsion package. Though the thermal propulsion package may be directly relevant to the underwater weapon applications, its relevance can also be extended to underwater vehicle applications. In this article, new areas for underwater propulsion based on thermal propulsion are explored.

2. FUTURE PROPULSION PACKAGES

In this study three areas are considered, viz, the conceptual idea: gaseous cavitation; the technology: stored chemical energy propulsion system; and the mechanism : unconventional engine.

2.1 Application of Gaseous Cavitation for Propulsion

The scientific community had a pleasant surprise when in the International Conference on Aeronautics held in Bangalore, an Indian scientist proposed the concept of 'hyperplane'. Out of the total weight of a rocket, the percentage weight of fuel and oxidiser is very high in comparison to that of the payload. If there is some means of collecting the oxidiser during the flight,

the payload can be accordingly improved. This, more or less, is the concept of 'hyperplane'.

In case of an underwater weapon, the payload is warhead. When the 'hyperplane' concept is applied to underwater propulsion, it may mean that the underwater vehicle must collect its required oxidiser from the surroundings—the sea water. Can this hypothetical situation be transferred into atleast a theoretical feasibility?

2.1.1 Gaseous Cavitation

It appears that this is possible by a phenomenon called gaseous cavitation. In most of the engineering contexts, cavitation is defined as the process of formation of vapour phase of liquid when the latter is subjected to reduced pressures at constant ambient temperature. Depending upon the magnitude of pressure reduction and the rate of application, a bubble may grow slowly due to diffusion of gas into the nucleus and thus contain mostly gas component. This is termed as 'gaseous cavitation'. For the growth of nuclei by diffusion, the pressure may be less or greater than the vapour pressure depending on the nuclei size and the degree of saturation¹. The critical pressure V_s versus bubble radius for gaseous cavitation for different saturation-to-static pressure ratios is shown in Fig. 1.

How are these critical pressures created to remove the dissolved/entrained oxygen in the sea water? Figure 2 gives the critical pressure for the inception of cavitation in sea water.

It is obvious that the surface of the sea water is saturated with oxygen. The percentage of the saturation depends upon whether it is ground or sea water. Depending upon the depth of travel of weapon/vehicle under water, which in turn decides the oxygen content in the surroundings and the power required by the vehicle, the approximate quantity of water that has to be passed through venturi can be arrived at. Figure 3 shows the results of the earlier experiments². The results obtained in these experiments have not been encouraging. The gaseous cavitation appears to be a

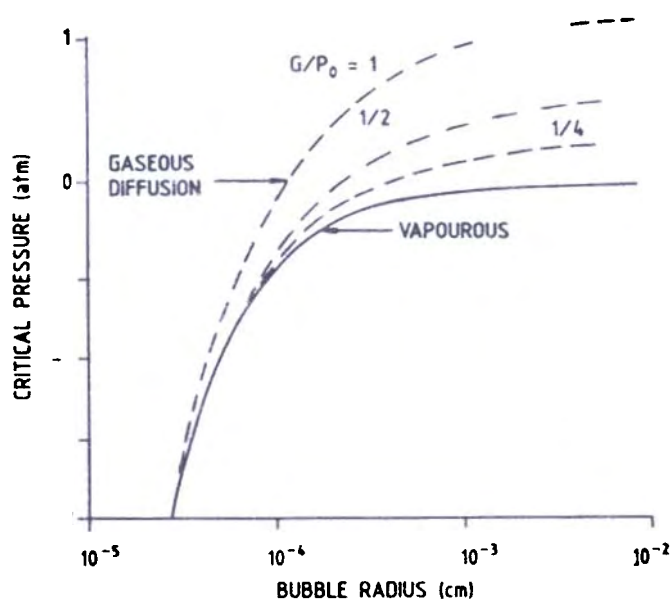

Figure 1 Critical pressure versus bubble radius for gaseous cavitation for different saturation-to-static pressure ratios.

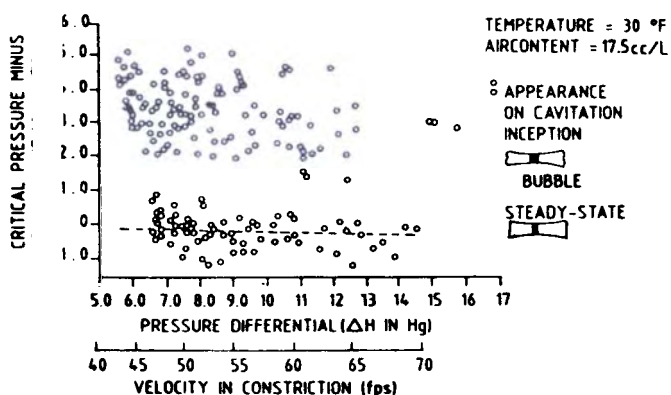

Figure 2 Critical pressure for inception of cavitation in sea water.

potent field for exploitation for underwater propulsion

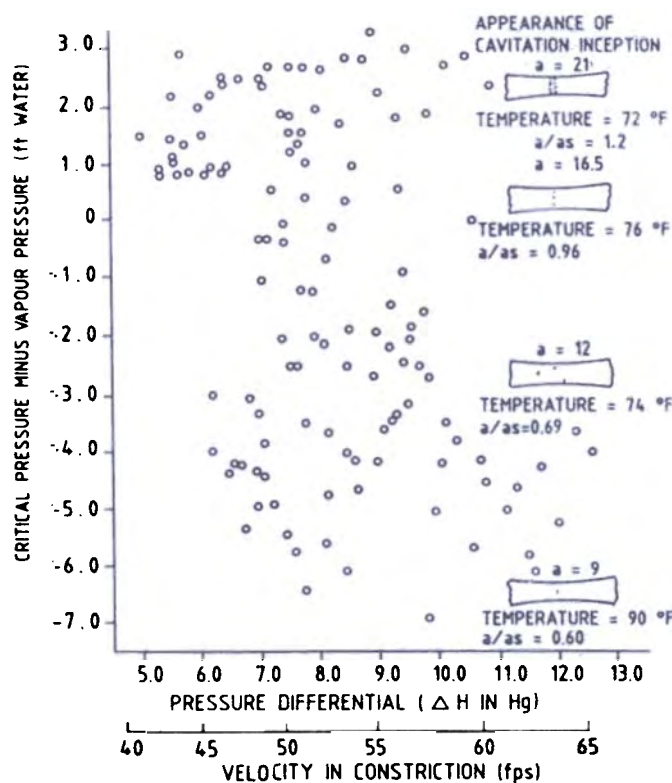

Figure 3. Result of earlier experiments on gaseous cavitation.

Though the application of gaseous cavitation appears to be a long-term goal, the use of SCEPS seems to be the reality of the day. The UK and the US have made very good progress in the use of this technology. Both laboratory models and actual power packs for use up to a power range of about 120 HP seem to have been developed. In India the work on SCEPS is yet to take off.

2.2 Stored Chemical Energy Propulsion System

This system is referred to as closed cycle thermal engine in UK. The major problem with underwater thermal propulsion is the hydrostatic pressure against which the gases are to be expanded. This pressure keeps changing depending upon the depth at which the weapon travels. This problem can be overcome through the use of closed cycle engine. In SCEPS, lithium stored in the form of rods reacts with sulphur hexafluoride to generate heat³. This heat is absorbed by water in the boiler which gets converted into high pressure superheated steam. The steam thus generated is expanded in a steam turbine to derive the mechanical power. The steam/vapour mixture is then cooled in a

THE BASIC REACTION EQUATION IS:

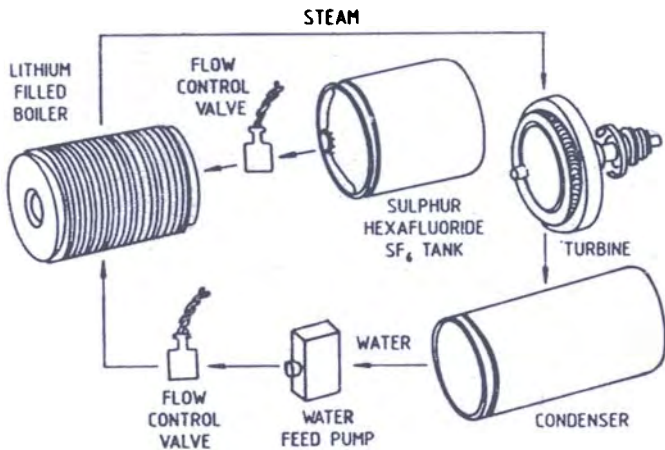

Figure 4. Schematic of a closed cycle engine.

hull mounted condenser using sea water as the cooling medium. Upon conversion to the liquid phase, the water is pumped back to the boiler and the cycle gets completed (Fig. 4).

The merits for using the lithium and sulphur hexafluoride combination are: (i) high specific energy; (ii) the reaction products are molten at normal bath temperature; and (iii) the volume occupied by the reaction products is actually less than the volume occupied by the original charge.

2.3 Unconventional Engine

The term conventional engine refers to that class of engines which have connecting rod and crankshaft mechanism. The unbalanced force component and the requirement of longer connecting rods for higher power requirements are some of the disadvantages of this type of mechanism.

For underwater thermal propulsion package for weapon applications, the volume and weight are at a high premium. The function of the connecting rod and crankshaft mechanism can be achieved by other mechanisms as well. The engines using these mechanisms are called unconventional engines. Based on the mechanisms used, three distinct types of unconventional engines—cam engine, swash plate engine, and wobble plate engine—are being tried for underwater applications⁴. Of the three engines, the wobble plate engine has certain advantages over the other two for the particular application under consideration.

A wobble plate engine is a specific type of swash plate engine wherein the engine shaft is provided with an inclined crank pin which can be rotated in a swash member. Means are so provided for constraining the movement of swash member that all the points at right angles to the inclined crank pin and at equal distances

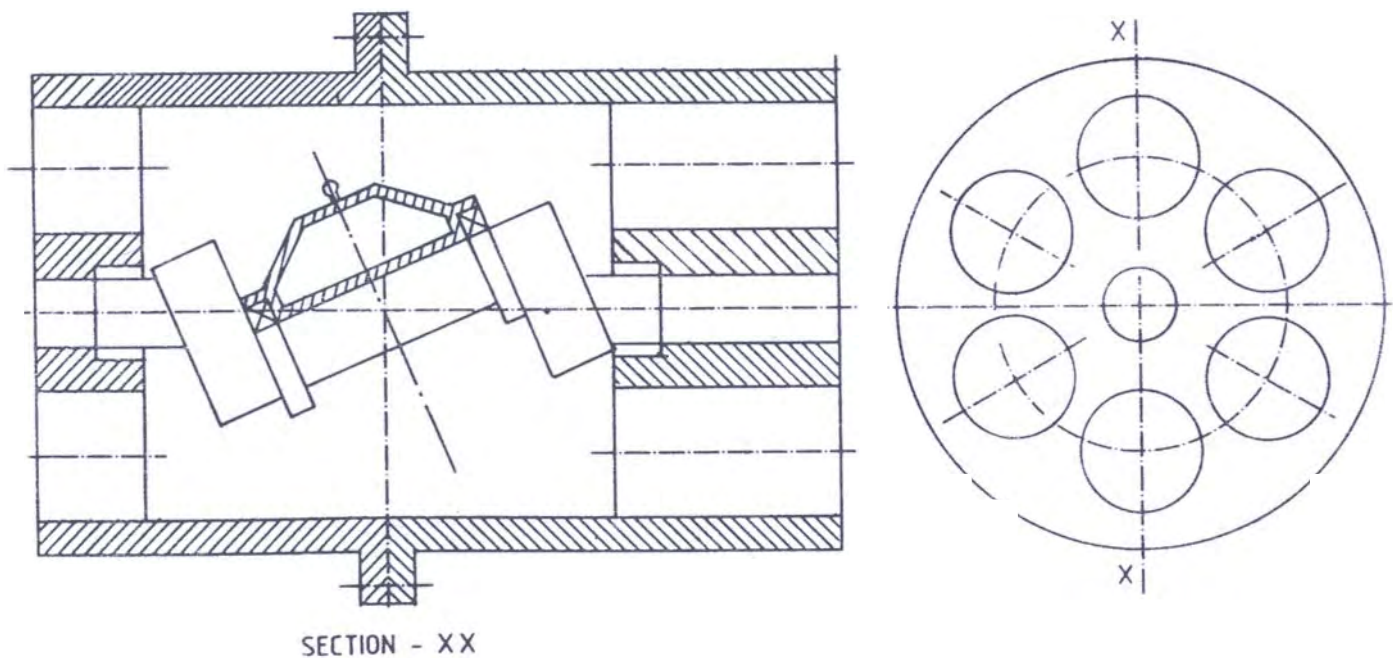

Figure 5. Schematic layout of wobble plate mechanism.

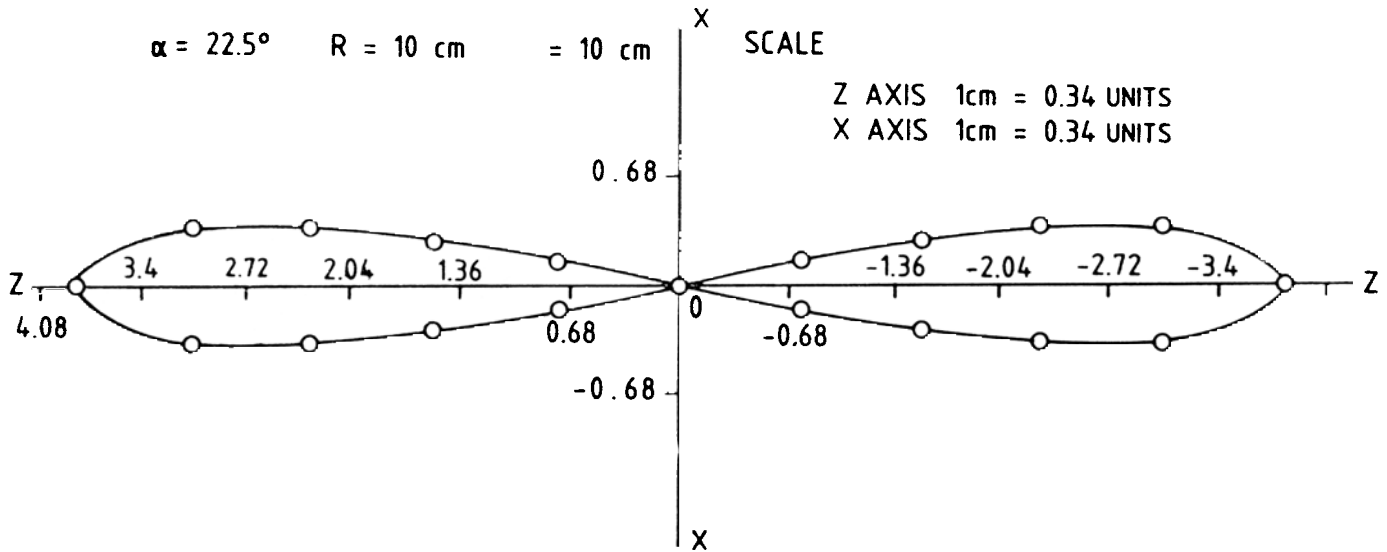

Figure 6. Locus of wobble plate joint.

therefrom, traverse different paths of same shape. The connecting rod is connected to the swash member in a manner that the two have only specific degree of freedom. Schematic arrangement of the wobble plate engine is shown in Fig. 5.

Though attempts were made to develop such engines as early as 1875, it was only very recently that some success has been achieved in the development of these engines abroad. The problem was that of not fully understanding and quantifying mathematically the governing equations of motion. A set of four closed equations based on kinematic, geometric, and motion constraints was solved. This indicated the motion of the wobble plate point to follow a lemniscate (similar to figure of eight) with varying chord. Physical models were made to validate the equations (Fig. 6).

3. CONCLUSION

In India, the work pertaining to the above is yet to take off. However, in the western countries, the work on SCEPS and the wobble plate engine has reached a very advanced stage. These systems are likely to be put in full operational use shortly and are expected to continue in service thereafter for a few decades.

REFERENCES

1. Strasberg: David Taylor Model Basin. 1957. Report No. 1078.
2. Crump, S.F. David Taylor Model Basin. 1949. Report No. 575.
3. Spence, W.A. Closed cycle thermal propulsion system for torpedoes. HMSO, London, 1988.
4. Gottfredson, R.K. *Journal of Engineering for Industry*, 1980, 102, 85-90.